

**EXH. DJL-7 (Apx. B)  
DOCKETS UE-240004/UG-240005  
2024 PSE GENERAL RATE CASE  
WITNESS: DAVID J. LANDERS**

**BEFORE THE  
WASHINGTON UTILITIES AND TRANSPORTATION COMMISSION**

**WASHINGTON UTILITIES AND  
TRANSPORTATION COMMISSION,**

**Complainant,**

**v.**

**PUGET SOUND ENERGY,**

**Respondent.**

**Docket UE-240004  
Docket UG-240005**

**APPENDIX B (NONCONFIDENTIAL) TO THE SIXTH EXHIBIT TO THE  
PREFILED DIRECT TESTIMONY OF**

**DAVID J. LANDERS**

**ON BEHALF OF PUGET SOUND ENERGY**

**FEBRUARY 15, 2024**



**Greenwater Tap Reliability**  
Corporate Spending Authorization (CSA)

Date Created:	Friday, February 10, 2023
Discretionary/ Non-Discretionary:	Discretionary
Multi Year Rate Plan:	Specific
Equity Impact:	Yes
Strategic Alignment:	Operate the Business-Reliability
Estimated In-Service Date:	Tuesday, October 31, 2028
Current State (Business Need):	<p>- Transmission Reliability: The Greenwater Tap experiences higher than average outage frequency and duration, mostly due to vegetation related outages and difficult access to the line. Specifically, the location of the transmission line on Forest Service Road 3700 represents a large impact on system reliability. Access Issues: PSE lacks sufficient easement access rights along 9 miles of FR 3700 ROW on the Greenwater Tap transmission path. - Channel Migration Zone (CMZ): 39 transmission poles were identified as at risk since they are within the Channel Migration Zone (CMZ) of the White River. - Obsolete Infrastructure: The Greenwater Tap is a 60+ year old 55 kV transmission supply in south King County. Transmission at 55 kV is a voltage level that PSE is phasing out completely and has become an obsolete voltage on the PSE transmission system. The spares for the Krain Corner 115 kV / 55 kV three phase transformers are almost 60 years old and are of questionable use. A loss of the transformers would result in significant issues with serving the load on the 55 kV system. - Power Quality: There have been past quality issues due to the 55kV Transmission has contacting the 12.47kV Distribution. - Operational Flexibility: The Greenwater Tap is fed at 55 kV radially from the Krain Corner (KRA) substation with the ability to switch the feed from Electron Heights (EHT) at Stevenson Switch (STE) which is slated for removal as part of the Enumclaw 55-115 kV conversion project. The alternate source from Electron Heights is being converted to 115kV and will not be a viable switching option in the future. Krain Corner currently has a main bus only configuration and requires de-energizing the entire Greenwater tap during maintenance of the substation or line equipment. - Storm Resiliency: The Greenwater Tap is in a remote region near the outer edge of PSE's distribution and transmission system. This area experiences outages with longer than average durations due to safety concerns, poor access, and weather conditions.</p>



**Greenwater Tap Reliability**  
**Corporate Spending Authorization (CSA)**

**Desired State (Proposed Solution):**

PSE determined the preferred solution that cost-effectively meets the Enumclaw – Greenwater electric transmission system needs is Alternative 3. The wires solution is subdivided into two phases of work: Phase 1 Scope: - Provide a new 115kV-55kV/34.5kV substation with a Circuit Switcher and 34.5kV circuit breaker -The system downstream of the new substation feeding Greenwater substation will remain at 55kV until Phase 2 is complete, where the system will be converted to 34.5kV. Phase 2 Scope: - Convert the existing Clay Creek (CLA) substation from 55kV to 34.5kV - Install 9.9 miles of UG conduit and conductor along Hwy 410 from the existing Transmission River crossing at Crystal River Ranch - Convert existing services along Hwy 410 from 12.47kV to 34.5kV as necessary.



**Greenwater Tap Reliability**  
Corporate Spending Authorization (CSA)

**Outcome/Results**  
**(What are the**  
**anticipated benefits):**

• Eliminates the aging infrastructure and 55 kV operating voltage of the Greenwater Tap o 34.5kV distribution voltage allows more flexibility and improves reliability • Allows for improved reliability along the Greenwater Tap o UG conversion will result in fewer tree/vegetation related outages o Locating the line along Hwy 410 will eliminate the need for cross-country route along 9 miles of FR 3700 where PSE does not have durable rights to use the road and eliminates the CMZ risk. • Maintains operational flexibility as the new 115kV source for the Greenwater Tap may be fed from KRA or EHT.



**Greenwater Tap Reliability**  
Corporate Spending Authorization (CSA)

**Dependencies:**

**Dependencies comment:**

**Escalation Included:**

**Total Estimated Costs:**

**Estimated Five Year Allocation:**

Funds Type	ID	Line Item Description	Previous Years Actuals	Fiscal 2024 Requested	Fiscal 2025 Requested	Fiscal 2026 Requested	Fiscal 2027 Requested	Fiscal 2028 Requested
Capital	W_R.10035.02.01.01	E Greenwater Tap 55 155kV Conversion	\$ 105,222	\$ 1,000,000	\$ 3,680,000	\$ 3,680,000	\$ 500,000	\$ 4,000,000

**Incremental O&M:**

**Qualitative Benefits:**

This project will improve reliability by reducing the frequency of outages caused by faults on the radial transmission line feeding Greenwater Substation. The new 34.5kV line connecting to Greenwater will be about 10-miles of underground and the distribution underbuild will be removed which will improve safety and reliability. The project will reduce 250,000 CMI annually for Greenwater customers. There will be cost savings resulting from a reduction in the need for emergency repair of damage to the radial tap and reduced tree-maintenance expense for 10 miles. The project will eliminate the 55kV-12kV transformer at Greenwater, reusing the existing 34.5kV transformer and add an 115kV/55kV/34.5kV transformer at WWR. The project has an iDOT score of 1.49.

**Quantitative Benefits:**

Quantitative Benefits	Benefit Type	Previous Years	Fiscal 2023	Fiscal 2024	Fiscal 2025	Fiscal 2026	Fiscal 2027	Fiscal 2028	Remaining Costs	Life Total

**Risk Summary:**

• Phase 1 risks include property acquisition and permitting for the new substation. Risk level varies depending on utilizing the existing WWR substation site or needing to find a new location. • Phase 2 risks include construction challenges while working in the vicinity of SR410 and permitting with WSDOT within Federation Forest State Park.



**Greenwater Tap Reliability**  
Corporate Spending Authorization (CSA)

Change Summary:

Planning Cycle	Change Summary	Last Update Date
2022 Baseline Cycle	This CSA has been migrated into the EPPM tool at go-live as part of the Phase 1 EPPM implementation effort. The projects in this CSA were previously approved for the 2023-2027 capital plan. Please refer to the original CSA document for additional information (if available.)	2/10/2023



**Greenwater Tap Reliability**  
Corporate Spending Authorization (CSA)

Approval History:

Approved By	Date Approved
Approved by Cost Center Owner: Pagano , Tony	4/3/2023
Approved by Director Sponsor: Roque Bamba	4/6/2023
Approved by Executive Sponsor: Koch , Dan	4/6/2023
CSA Status changed to Approved	4/6/2023
Approved by Cost Center Owner: Lim , Thina	12/5/2023
Approved by Director Sponsor: Lim , Thina	12/5/2023
Approved by Executive Sponsor: Lim , Thina	12/5/2023
CSA Status changed to Approved	12/5/2023
Approved by Cost Center Owner: Pagano , Tony	1/25/2024
Approved by Director Sponsor: Bamba , Roque	1/26/2024
Approved by Executive Sponsor: Vargo , Michelle	2/1/2024
CSA Status changed to Approved	2/1/2024



# Enumclaw – Greenwater Electric System Needs Assessment



Mt. Rainier, Washington

## Strategic System Planning August, 2023

Classification: Sensitive

*This document contains Critical Energy Infrastructure Information (CEII)  
The use or disclosure of which is protected.*



**Enumclaw – Greenwater – Needs Assessment**



# Enumclaw – Greenwater Electric System Needs Assessment

**Prepared By:**

Colin O’Brien, PE, *Strategic System Planning*  
David Meyer, PE, *Strategic System Planning*

**Reviewed By:**

Rachit Arora, PE, *Strategic System Planning*  
Eleanor Ewry, PE, *Supervisor - Strategic System Planning*

**Approved By:**

DocuSigned by:  
*Ryan Lambert*  
48EEB5A77F87404...

08/30/2023

---

*Ryan Lambert, PE*  
*System Planning, Manager*

*Date*

DocuSigned by:  
*David Landers*  
B6002897FD5542C...

09/24/2023

---

*David Landers, PE*  
*System Planning, Director*

*Date*

## Strategic System Planning August, 2023

Classification: Sensitive  
*This document contains Critical Energy Infrastructure Information (CEII)  
The use or disclosure of which is protected.*

## Enumclaw – Greenwater – Needs Assessment

---

## Table of Contents

---

Table of Contents.....	3
List of Figures.....	4
List of Tables.....	5
Executive Summary.....	6
Needs & Concerns.....	6
1 Introduction.....	8
1.1 Study Objective.....	8
2 Background.....	9
2.1 Area Description.....	9
2.2 Transmission Lines.....	10
2.3 Substations.....	11
2.4 Protection System.....	11
2.5 Existing Distribution Projects in the Area.....	11
2.5.1 Greenwater 13 Crystal River Ranch Tree Wire.....	11
2.5.2 Greenwater 16 Minor Road Conversion.....	11
2.6 Existing Transmission Projects in the Area.....	11
3 Study Assumptions.....	13
4 Transmission Power Flow Review.....	14
4.1 Steady State Thermal and Voltage Limits.....	14
4.2 Transmission Power Flow Results.....	14
5 Distribution Capacity Assessment.....	15
5.1 Weyerhaeuser White River.....	15
5.2 Clay Creek.....	15
5.3 Greenwater.....	15
6 Infrastructure Assessment.....	17
6.1 Transmission Lines.....	17
6.2 Transmission Poles.....	17
6.3 Substations.....	18
6.3.1 Krain Corner.....	18
6.3.2 Clay Creek.....	18
6.3.3 Greenwater.....	19
7 Reliability Assessment.....	20
7.1.1 Power Quality.....	21
8 3700 Forest Road Transmission Route Issues.....	22
8.1.1 Easements for Right of Way.....	23
8.1.2 Channel Migration Zone.....	23
9 Conclusions on Needs Assessment.....	26
9.1 Statement of Needs and Concerns.....	26
Appendix A Glossary.....	28

Classification: Sensitive

*This document contains Critical Energy Infrastructure Information (CEII)  
The use or disclosure of which is protected.*

**Enumclaw – Greenwater – Needs Assessment**

---

## List of Figures

---

Figure 2-1: Aerial view of Greenwater Tap.....	9
Figure 5-1. Projected Crystal Mountain Load Forecast .....	16
Figure 6-1: Transmission Pole Failure Rate vs Install Date .....	17
Figure 8-1: Greenwater Tap – Forest Road 3700.....	22
Figure 8-2: Muckleshoot Land Purchase (Seattle Times).....	23
Figure 8-3: Aerial view of Greenwater Tap, CMZ Areas .....	24
Figure 8-4: Area 1, South of Federation Forest Park .....	24
Figure 8-5: Area 2, Near Greenwater .....	25

Classification: Sensitive

*This document contains Critical Energy Infrastructure Information (CEII)  
The use or disclosure of which is protected.*

**Enumclaw – Greenwater – Needs Assessment**

---

## List of Tables

---

Table 2-1: Greenwater Transmission Line Data.....	10
Table 4-1: Greenwater Tap – Power Flow Analysis Results.....	14
Table 6-1: Expected Pole Replacements.....	18
Table 6-1: Greenwater Transmission Reliability Data (Years 2013 – 2017).....	20

Classification: Sensitive

*This document contains Critical Energy Infrastructure Information (CEII)  
The use or disclosure of which is protected.*

**Enumclaw – Greenwater – Needs Assessment**

---

## Executive Summary

---

An electric system needs assessment was performed for the Enumclaw – Greenwater area, including the Greenwater Tap 55 kV transmission system, 34.5kV distribution system, and 12.5 kV distribution system in Southeast King County. The analysis detailed in this report established that there are existing needs and concerns on the electric system that continue over the next ten years.

The most significant need identified in this study is the reliability of the 55 kV Greenwater Tap transmission line. This 26-mile radial transmission line experiences several more outages than is typical for a PSE transmission line, with durations lasting significantly longer than average. Additionally, the 55 kV infrastructure in the PSE system is no longer being installed or supported with most of the old 55 kV equipment being replaced and configured for 115 kV operation. The 115 kV/55 kV transformer at Krain Corner substation does not have a reliable spare and an outage of the transformer would result in the entire Greenwater Tap being fed radially at 55 kV from White River, located 14 miles away from Krain Corner.

### Needs & Concerns

---

The assessment has identified the following needs and concerns on the Greenwater Tap:

#### Needs:

- **Transmission Reliability:** The location of the transmission line along Forest Road 3700 Right Of Way (FR 3700 ROW) has a strong impact on the reliability of the line. There are numerous tree-related outages that have extended restoration time due to the length of time required to patrol the line and resolve the cause of the outage. The number and duration of the sustained outages from 2015-2019 are over 300% larger than average PSE transmission lines.
- **Land Rights Issues:** PSE lacks sufficient land rights along 9 miles of FR 3700 ROW on the Greenwater Tap transmission path.
- **Channel Migration Zone (CMZ):** Several transmission poles of the Greenwater Tap were identified as at risk of being washed away since they are within the Channel Migration Zone (CMZ) of the White River.

#### Concerns

- **Obsolete Infrastructure:** The Greenwater Tap is a 55 kV transmission supply in south King County. The 55 kV voltage level has limited footprint remaining in the PSE service area, and long term PSE plans include converting the remaining 55 kV voltage level system to PSE's current standard voltages in most locations. The spares for the Krain Corner 115 kV/55 kV three phase transformer are almost 60 years old and may not be reliable. A loss of the Krain Corner 115 kV/55 kV transformer will result in significant issues in serving the load on the 55 kV system.
- **Power Quality:** There have been several customer claims due to Power Quality issues when the 55kV Transmission has contacted 12.47kV Distribution and caused equipment failures.

Classification: Sensitive

*This document contains Critical Energy Infrastructure Information (CEII)*

*The use or disclosure of which is protected.*

**Enumclaw – Greenwater – Needs Assessment**

- **Operational Flexibility:** The Greenwater Tap is fed radially from the Krain Corner substation. The alternate source from Electron Heights is being converted to 115kV and will not be a viable switching option. Krain Corner currently has a Main-Bus Only configuration and requires de-energizing the Greenwater Tap line for maintenance of substation or line equipment.
- **Storm Resiliency:** The Greenwater Tap serves a remote area at the outer edge of PSE's electric system. This area experiences outages with longer than average durations due to safety, access, and weather conditions.

Classification: Sensitive

*This document contains Critical Energy Infrastructure Information (CEII)  
The use or disclosure of which is protected.*

**Enumclaw – Greenwater – Needs Assessment**

---

# 1 Introduction

---

An electric system needs assessment was performed for the Enumclaw - Greenwater area in South King County. The analysis detailed in this report established that there are reliability, infrastructure, land rights, and power quality needs and concerns for the study area presently and over the next 10 years.

## 1.1 Study Objective

---

The study objective was to assess the existing and future needs of the Greenwater Tap.

This report reviews the transmission and distribution infrastructure for present and future viability. The following tasks were completed as part of this study review and are discussed in this report:

- Infrastructure Investigation
- Reliability Analysis
- Power Quality Analysis
- Power Flow Results Review

Classification: Sensitive

*This document contains Critical Energy Infrastructure Information (CEII)  
The use or disclosure of which is protected.*

**Enumclaw – Greenwater – Needs Assessment**

---

## 2 Background

---

The Greenwater Tap consists of approximately 26 miles of radial 55 kV transmission line from Krain Corner substation to Greenwater substation in South King County. The transmission line is a single feed to the Greenwater substation that serves a total 907 customers, including the town of Greenwater and commercial customers such as Boeing and the Crystal Mountain resort.

### 2.1 Area Description

---

The map in Figure 2-1 shows an aerial view of the Greenwater Tap transmission line. See Appendix B for One-Line diagram of the existing transmission line.

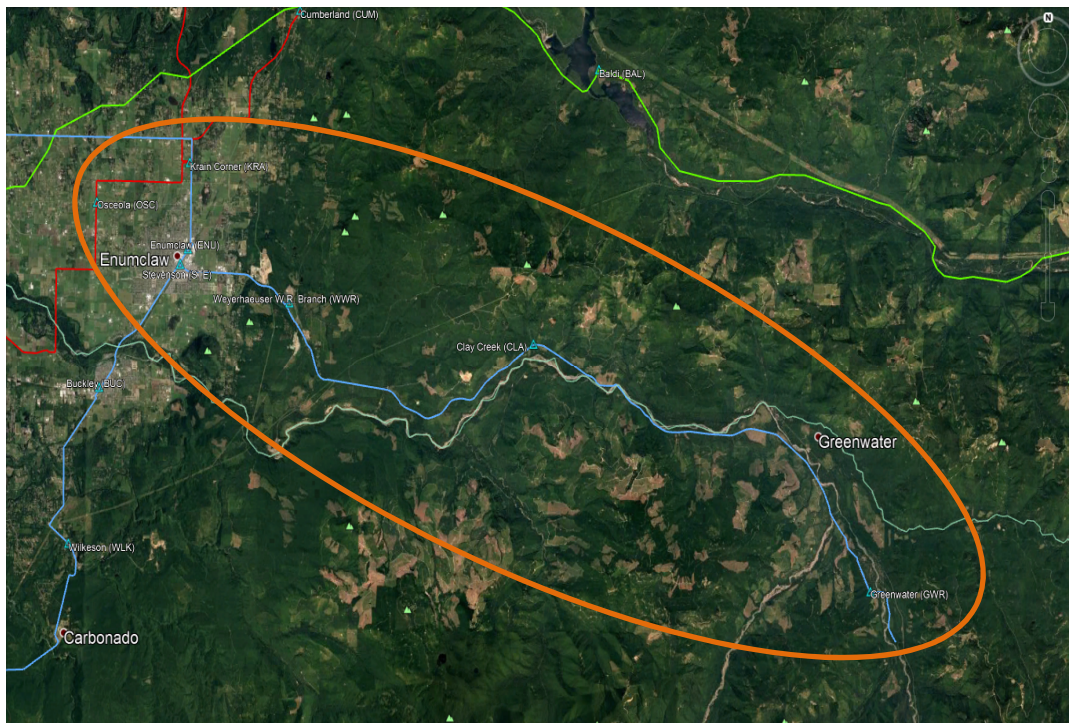

**Figure 2-1: Aerial view of Greenwater Tap**

The primary transmission supply to the Greenwater Tap comes from a 115 / 55 kV transformer at PSE's Krain Corner substation. The Greenwater Tap is the only transmission source to the Greenwater area and to all the loads between Krain Corner and Greenwater, including Weyerhaeuser White River and Clay Creek substations. The Krain Corner substation is fed from both 115 kV and 55 kV transmission lines, including a 55kV transmission line from White River substation. White River is a secondary 55kV source for the area that cannot effectively serve customers on the Greenwater Tap due to voltage limitations. There is currently an active project to convert the existing 55 kV line to 115 kV from Enumclaw to Electron Heights. The design for the Enumclaw to Electron Heights conversion currently plans on converting a portion of the existing Greenwater Tap conductor from 55kV to 115 kV and

Classification: Sensitive

*This document contains Critical Energy Infrastructure Information (CEII)*

*The use or disclosure of which is protected.*



**Enumclaw – Greenwater – Needs Assessment**

utilizing it for the new Enumclaw to Electron Heights transmission line. This modification requires a change to the Greenwater Tap transmission line since it will lose the existing 55kV source.

The Krain Corner substation bus is a Main Bus configuration, which lacks operating flexibility and requires an outage for the Greenwater Tap during substation maintenance. The limited operational flexibility to serve customers in the area is a concern. Transmission Planning Guidelines recommend that the transmission bus be replaced with a ring bus when there are 5 or more elements. Krain Corner currently has 5 elements on the 115kV bus and a bus reconfiguration should be considered if any lines are added to the bus.

**2.2 Transmission Lines**

The Greenwater Tap transmission line consists of different conductors and construction. The conductors, per unit impedance, and ratings of the different conductors used for the Greenwater Tap are shown below in Table 2-1. A significant portion (almost 75%) of the Greenwater Tap consists of the 2/0 ACSR conductor.

**Table 2-1: Greenwater Transmission Line Data**

Line Segment	Conductor Type	Distance (mi)	Impedance			MVA Rating			
						Winter		Summer	
			Per Unit			Normal	Emer.	Normal	Emer.
			R	X	B	10° C	0° C	35°C	30°C
Krain - Stevensen	795 AAC	2.3	0.01	0.05	0.00	84	94	54	62
	4/0 ACSR	0.2	0.00	0.01	0.00	38	40	23	26
	397.5 ACSR	0.0	0.00	0.00	0.00	55	61	36	41
	Subtotal	2.6	0.01	0.05	0.00	38	40	23	26
Stevensen - W.W.R.	397.5 ACSR	3.0	0.02	0.07	0.00	66	71	52	55
W.W.R. - Clay Creek	4/0 ACSR	0.2	0.00	0.01	0.00	38	40	23	26
	397.5 ACSR	0.8	0.01	0.02	0.00	66	71	52	55
	2/0 ACSR	7.4	0.16	0.19	0.00	27	30	18	20
	Subtotal	8.5	0.17	0.21	0.00	27	30	18	20
Clay Creek - Greenwater	2/0 ACSR	11.6	0.25	0.29	0.00	27	30	18	20
Total = Krain Corner - Greenwater		25.7	0.45	0.61	0.00	27	30	18	20

The line section from Krain Corner to Weyerhaeuser White River Substation (WWR) is mostly constructed using 795 AAC and 397.5 ACSR, except for 0.22 miles that are constructed of 4/0 ACSR. The 4/0 ACSR has less than half the capacity (MVA rating) of the 795 AAC and 397.5 ACSR conductors, and has 2 to 4 times the resistance per mile as well, which further limits flow on the line. The line section from WWR to Clay Creek is constructed of 0.79 miles of 397.5 ACSR and 0.24 miles of 4/0 ACSR. The line section also has 1.5 miles of 2/0 ACSR that has limited capacity. The 2/0 ACSR has an even lower capacity than the 4/0 ACSR, and a similar high resistance per mile.

The line section from Clay Creek to Greenwater substation is constructed of 11.6 miles of 2/0 ACSR. Again, this conductor has limited capacity and significantly higher impedance than the 4/0 and other conductors used on the Greenwater Tap.

Classification: Sensitive

*This document contains Critical Energy Infrastructure Information (CEII)*

*The use or disclosure of which is protected.*

## Enumclaw – Greenwater – Needs Assessment

The Quail 2/0 conductor is used for almost 74% of the Greenwater Tap, but counts for almost 90% of the total Greenwater Tap resistance. The use of this conductor has a large impact on the reduced capacity of the Greenwater Tap.

### 2.3 Substations

---

There are several distribution substations fed from the 55 kV Greenwater Tap transmission system. These include Weyerhaeuser White River (WWR), Clay Creek (CLA), and Greenwater (GWR). WWR is a customer owned substation that was used to serve the Weyerhaeuser Mill, until it was recently closed and sold. The current customer has committed to receiving service from a nearby distribution circuit, leaving the substation unused. The Clay Creek substation serves communications towers and equipment on the top of nearby mountains. The Greenwater substation serves the town of Greenwater and residential communities of Crystal River Ranch and surrounding residential areas. The Greenwater substation also includes a 34.5 kV distribution feeder that serves the Crystal Mountain ski resort.

### 2.4 Protection System

---

The protection system on the Greenwater Tap consists of a 55 kV breaker at Krain Corner and 55 kV switches at WWR and Clay Creek that have the capability for automatic switching. The Greenwater substation has a circuit switcher connected to the high side of the transformer and 12 kV breakers for the two distribution feeders.

### 2.5 Existing Distribution Projects in the Area

---

There have been recent projects in the Enumclaw – Greenwater area to address existing distribution reliability issues.

#### 2.5.1 Greenwater 13 Crystal River Ranch Tree Wire

The project upgraded approximately 1 mile existing overhead distribution feeder along Alpine Drive to 336 ACSR Tree Wire, from Greenwater substation to Willow Tree Way. Additionally, the project includes replacing XX miles of distribution lateral circuit along Meadow Way and Crystal Drive to #2 ACSR Tree Wire. This project was completed in 2019.

#### 2.5.2 Greenwater 16 Miner Road Conversion

This project is planned to convert approximately 3 miles of existing 4/0 ACSR overhead circuit to underground distribution. The project will begin downstream of Recloser E429 on Miner Road and follow the existing feeder route, ending at Gang-Op switch number X77681. This project was completed in 2022.

### 2.6 Existing Transmission Projects in the Area

---

The existing 55 kV line from Electron Heights to Enumclaw is currently being converted to 115 kV. The line voltage conversion to 115 kV will significantly improve transmission reliability for the Krain Corner substation and benefit all lines served out of Krain Corner (including the Greenwater Tap). The planned 115 kV converted line will provide a new 115 kV source to Krain Corner substation and keep the station

Classification: Sensitive

*This document contains Critical Energy Infrastructure Information (CEII)*

*The use or disclosure of which is protected.*

**Enumclaw – Greenwater – Needs Assessment**

energized under multiple contingency scenarios (N-1-1) on the 115 kV system supplying Krain Corner. However, the project does not address the needs and concerns of the Greenwater Tap line related to reliability, power quality, and land rights for the line. This project is planning to utilize a small portion of the Greenwater Tap conductor just south of the Enumclaw substation and converting it to 115 KV, which will require a new source for the Greenwater Tap. See Appendix B for One-Line Diagram details.

Classification: Sensitive

*This document contains Critical Energy Infrastructure Information (CEII)  
The use or disclosure of which is protected.*

**Enumclaw – Greenwater – Needs Assessment**

---

### **3 Study Assumptions**

---

The following assumptions were used in the Greenwater Tap needs assessment:

- The assessment horizon selected was the ten year period from 2018 to 2027 to be consistent with the F2017 Corporate Load Forecast. Outside of Crystal Mountain Resort, there is limited load growth expected at the Greenwater substation due to land use and zoning restrictions. Rather than using the county level corporate load forecast to determine load growth, this study looks at specific load growth at Crystal Mountain to determine system capacity requirements. See Section 5 for distribution load forecast details.
- Reliability data used in this study are all outages from 2013 through 2017. After substantial completion of this report, an additional reliability study was performed using outages from 2015 through 2019.

Following were the criteria followed:

- Power flow analysis consistent with North American Electric Reliability Corporation (NERC) TPL-001-4 and TPL-001-WECC-CRT-3.2 requirements.
- Assessment is consistent with PSE's Transmission Planning Guidelines and Distribution Planning Guidelines.

Classification: Sensitive

*This document contains Critical Energy Infrastructure Information (CEII)*

*The use or disclosure of which is protected.*

## Enumclaw – Greenwater – Needs Assessment

## 4 Transmission Power Flow Review

The transmission needs assessment examined the transmission system performance through a review of the past 2017 PSE TPL assessment. The North American Electric Reliability Corporation (NERC) and Western Electric Coordinating Council (WECC) have established transmission planning (TPL) standards to evaluate transmission line capacity and the ability of the transmission system to respond to expected outage situations and operating conditions. PSE assesses its transmission system annually to comply with the NERC and WECC TPL standards and criteria.

Table 1 of the NERC TPL-001-4 standard is used to identify the contingencies to be tested, and include all PSE Bulk Electric System (BES) elements. Key BPA and neighboring utility elements are also tested for their impact on PSE's system.

### 4.1 Steady State Thermal and Voltage Limits

The following limits were used when testing for the contingencies specified by the NERC and WECC TPL:

- All lines and transformers must stay within 100% of the thermal limits established for normal or long term emergency ratings.
- All buses must stay between 90% and 110% of the per-unit voltage for the contingencies studied.
- No bus voltage may swing more than 8% for a single contingency.

### 4.2 Transmission Power Flow Results

PSE's South King County / Pierce County transmission system was evaluated during the 2017 annual assessment for the NERC Transmission Planning reliability standards. The results are shown in Table 4-1 and indicated that there are certain P6 contingencies that will result in a low voltage condition and possible voltage collapse at Krain Corner.

**Table 4-1: Greenwater Tap – Power Flow Analysis Results**

Year	Season	Project Addition	Contingency Types	Simulation Issues	Resolution Method	
					Short Term	Long Term
2018-2019	Heavy Winter	n/a	P6 (N-1-1)	Under Voltage Conditions	UVLS	55kV Enumclaw - Electron Heights Conversion
2019	Heavy Summer		P6 (N-1-1)	Under Voltage Conditions	UVLS	
2022-2023	Heavy Winter	55kV Enumclaw - Electron Heights Conversion	P6 (N-1-1)	n/a	n/a	
2023	Heavy Summer		P6 (N-1-1)	n/a	n/a	
2026-2027	Heavy Winter		P6 (N-1-1)	n/a	n/a	
2027	Heavy Summer		P6 (N-1-1)	n/a	n/a	
System Issues Found During Analysis						

An Under Voltage Load Shed (UVLS) scheme has been implemented at Krain Corner to trip the 115 kV load during low voltage conditions to mitigate the voltage collapse and allow the 55 kV system to remain online to serve customers. A long term solution to the issue is the existing project to convert the 55 kV line from Enumclaw to Electron Heights to 115 kV. The conversion of the line will result in an additional 115 kV source into Krain Corner, allowing for the system to have adequate system response during P6 contingencies in the area.

Classification: Sensitive

*This document contains Critical Energy Infrastructure Information (CEII)*

*The use or disclosure of which is protected.*

---

## 5 Distribution Capacity Assessment

---

PSE's Planning Department monitors electrical loads throughout the entire service territory in anticipation of meeting system needs and to correct deficiencies in the electrical system. The existing capacity of each of the distribution substations fed from the 55 kV Greenwater Tap transmission system is compared with the forecasted load for the region.

Typically, the loads of a region are forecasted using the county-level corporate load forecast. Due to the remote nature of the Greenwater Tap, the King County corporate load forecast does not represent accurate growth. The residential customers are expected to grow much slower than the forecast, while certain commercial customers are projecting larger than expected growth. Instead of using the county level corporate load forecast, the anticipated load growth at each substation is analyzed individually and any substation or feeder level capacity needs will be identified.

### 5.1 Weyerhaeuser White River Substation

---

WWR is currently a customer owned substation. The customer has submitted an application to receive 12.47kV primary metered service from a nearby distribution line, which will leave the WWR substation unused.

Due to restrictions in zoning of the property, the need to serve increased load due to development is not a future concern at this time.

All load from WWR substation was omitted from the distribution capacity study as the only customer fed from the substation is being transferred to a separate part of the distribution system.

### 5.2 Clay Creek Substation

---

The Clay Creek substation is used to serve communications load on the nearby mountains. The substation consists of two single-phase transformers that are used to feed the load<sup>1</sup>.

There is no anticipated growth for the Clay Creek substation loads.

### 5.3 Greenwater Substation

---

The Greenwater substation has recently been rebuilt to address the needs in the area. The substation has two transformers, a 55 kV / 12 kV transformer to serve the distribution customers in the area, and a 12 kV / 35 kV step-up transformer for the feeder that serves customers up to, and including Crystal Mountain. The equipment and infrastructure at Greenwater substation is in good condition.

The Greenwater substation feeds 899 customers via a standard 25 MVA distribution transformer and two 12.47kV distribution circuits. The majority of these customers are residential properties in the town of Greenwater, Crystal River Ranch, Silver Springs Campground, and Crystal Mountain Resort.

---

<sup>1</sup> Only one transformer is utilized at a time. A spare transformer exists on site in case of outages / issues with the current line, and also to more easily and quickly allow switching to use of a spare 12 kV single phase feeder to the customers.

Classification: Sensitive

*This document contains Critical Energy Infrastructure Information (CEII)*

*The use or disclosure of which is protected.*

**Enumclaw – Greenwater – Needs Assessment**

Outside of Crystal Mountain Resort, there is limited load growth expected at the Greenwater substation due to land use and zoning restrictions. Rather than using the county level corporate load forecast to determine load growth, this study looks at specific load growth at Crystal Mountain to determine system capacity requirements.

The Crystal Mountain load growth is summarized in the Crystal Mountain Master Development Plan. This document and meetings with Crystal Mountain leadership helped determine the forecasted plans for the resort within the study timeframe. Based on these load additions, the distribution load forecast is shown below in Figure 5-1.

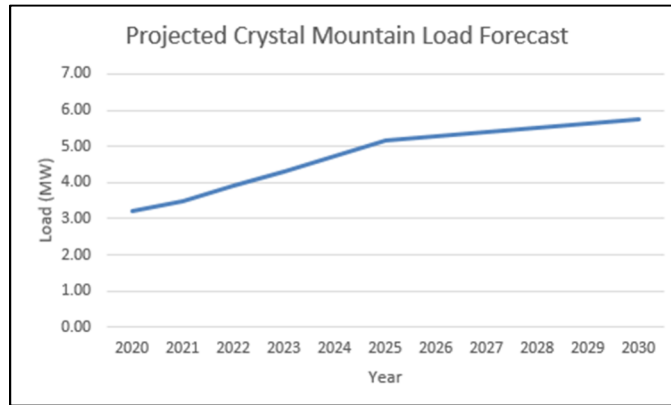

**Figure 5-1. Projected Crystal Mountain Load Forecast**

This study shows there are presently no distribution capacity needs or concerns on the Greenwater Tap.

Classification: Sensitive

*This document contains Critical Energy Infrastructure Information (CEII)  
The use or disclosure of which is protected.*

## Enumclaw – Greenwater – Needs Assessment

## 6 Infrastructure Assessment

An analysis of the Enumclaw - Greenwater area was completed to assess the condition of the equipment used on the transmission system in the area. This condition assessment includes the equipment of the transmission line of the Greenwater Tap and the substations connected to the line.

### 6.1 Transmission Lines

The Greenwater Tap transmission line consists of different conductors and construction as discussed in Section 2.2. The transmission line is sufficient to handle the existing load on the Greenwater Tap, even though significant portions of the line are constructed with 2/0 ACSR. Load additions at Crystal Mountain require the use of soft-start controls for the large motors used for the water pumps that support snowmaking equipment. The small conductor and high (comparatively) resistance of the 2/0 conductor restricts the potential for the Greenwater Tap to support future load additions.

### 6.2 Transmission Poles

The condition of the poles of the Greenwater Tap was analyzed. The analysis was completed for the three different line sections that comprise the Greenwater Tap. These sections are Krain Corner – Weyerhaeuser, Weyerhaeuser – Clay Creek, and Clay Creek – Greenwater. This analysis included evaluating the average age of the poles within a 15 year timeframe, or the age of the poles in the year 2034.

The PSE Asset Management group has quantified the risk / need for replacement of poles based on age, as shown below in Figure 6-1. T-Reject represents the percentage of poles that are showing signs of wear and expected failure within the next 3 years. T-Priority represents the percentage of poles with significant wear that need to be replaced within the next year.

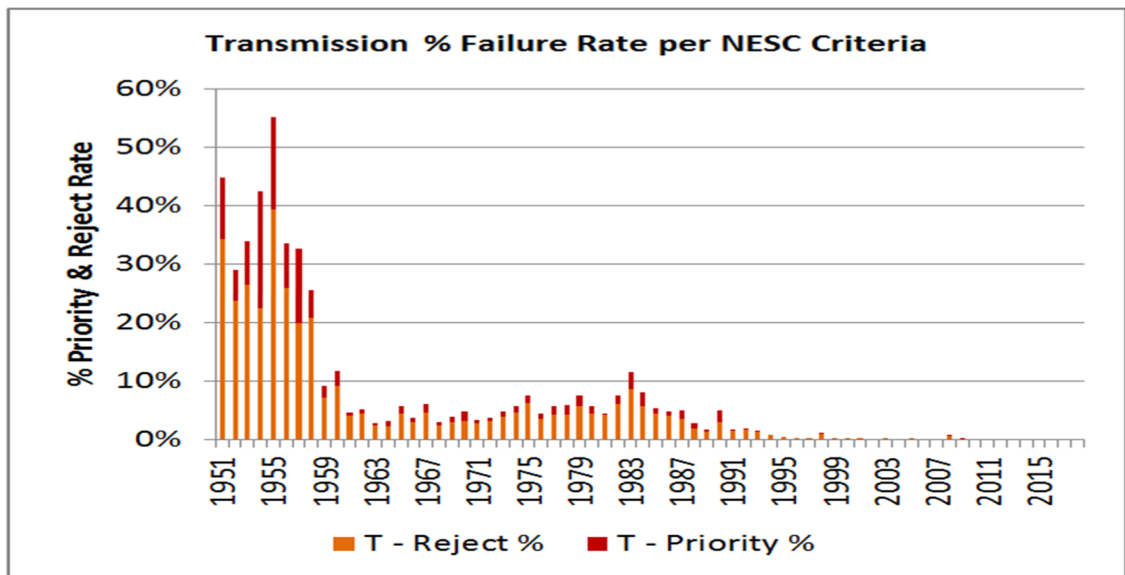

Figure 6-1: Transmission Pole Failure Rate vs Install Date

Classification: Sensitive

*This document contains Critical Energy Infrastructure Information (CEII)*

*The use or disclosure of which is protected.*



**Enumclaw – Greenwater – Needs Assessment**

The data was combined to determine the total number of poles that will need to be replaced within the next 15 years for each line section. The results are shown below in Table 6-1. The results show that it can be expected that 20% of the poles (16) on the Krain Corner – Weyerhaeuser section will need to be replaced within 15 years. Similarly, 30% (38 poles) for the Weyerhaeuser – Clay Creek line section and 43% (69 poles) for the Clay Creek – Greenwater line section need to be replaced in the next 15 years.

**Table 6-1: Expected Pole Replacements**

Section	Total Number of Poles	Poles to be Replaced in 15 Years	
		Number	%
Krain Corner – Weyerhaeuser	86	16	19%
Weyerhaeuser – Clay Creek	128	38	30%
Clay Creek – Greenwater	162	69	43%

This analysis shows that a significant proportion – a total of 123 out of 376 (or approximately 33 percent) transmission poles on the Greenwater Tap line will require replacement in the next 15 years.

### 6.3 Substations

---

Infrastructure analysis was completed for each of the substations on the Greenwater Tap to determine their condition and potential risk that would impact customers.

#### 6.3.1 Krain Corner

The Krain Corner substation is the main substation feeding load in the area. The substation consists of 115 kV and 55 kV buses. The 115 kV lines from White River, Electron Heights and Berrydale serve as the main source of power to serve the load in the area.

The 115 / 55 kV transformer at Krain Corner is almost 45 years old. The transformer is no longer supported by PSE and a spare has not been purchased for this unit. An outage of the transformer at Krain Corner would result in the Greenwater Tap being fed radially from White River, resulting in significant risk to the Greenwater Tap customers and PSE, as a second outage on the 55 kV line would result in blackout for the 55 kV customers.

A recent project replaced the 115 kV breakers at Krain Corner, but relay replacements were not included in that effort. Additionally, the Krain Corner substation is a main bus only configuration and any work or maintenance at the substation requires an outage for the entire bus.

#### 6.3.2 Clay Creek

The substation consists of two single-phase transformers that are used to feed the distribution load. Only one transformer is utilized at a time. A spare transformer exists on site in case of outages / issues with the current line, and also to more easily and quickly allow switching to use of a spare 12 kV single phase feeder to the customers.

Classification: Sensitive

*This document contains Critical Energy Infrastructure Information (CEII)*

*The use or disclosure of which is protected.*

**Enumclaw – Greenwater – Needs Assessment****6.3.3 Greenwater**

The Greenwater substation has recently been rebuilt to address the needs in the area. The substation has two transformers, a 55 kV / 12 kV transformer to serve the distribution customers in the area, and a 12 kV / 35 kV step-up transformer for the feeder that serves customers up to, and including Crystal Mountain. The equipment and infrastructure at Greenwater is in good condition.

The distribution feeder that feeds Crystal Mountain includes a 2.75 MW diesel generator at the end of the circuit that can be used to provide backup power. The generator is primarily used to provide backup power for Crystal Mountain, but is configured to pick up additional Greenwater customers as loading allows.

Classification: Sensitive

*This document contains Critical Energy Infrastructure Information (CEII)  
The use or disclosure of which is protected.*

## Enumclaw – Greenwater – Needs Assessment

## 7 Reliability Assessment

The reliability of the Enumclaw – Greenwater area was assessed to determine the performance of the transmission line and also its impact on customer interruptions. Typical transmission lines form part of a networked system, allowing for outages of a transmission line or multiple transmission lines to occur without resulting in interruptions for customers. Unlike most transmission lines, the Greenwater Tap is a single radial transmission line, similar to a distribution line. An outage of the Greenwater Tap directly results in interruptions to customers. Therefore, metrics that are typically reserved for distribution lines can also be used to quantify the reliability issues of the Greenwater Tap transmission line.

The Greenwater Tap was divided up into three different sections for analysis, the Krain Corner – WWR, the WWR - Clay Creek section, and the Clay Creek – Greenwater section. The line sections were chosen by the location of the switches used for automatic switching on the Greenwater Tap. The automatic switching controls in addition to reclosing of the 55 kV breakers at Krain Corner attempt to sectionalize the Greenwater Tap and clear faults while restoring customers in an efficient and automatic manor. As the Greenwater Tap is radial, faults on the first section (Krain Corner – WWR) will result in sustained interruptions of the entire Greenwater Tap. Conversely, faults at the end of the Tap, near Greenwater, will result in isolation of the line at WWR or Clay Creek, allowing those customers to be restored and served.

The outage analysis included quantification of the number of outages for each section, if the outage resulted in a sustained or momentary interruption, and the duration of the interruption. The results of the analysis are shown below in Table 7-1.

**Table 7-1: Greenwater Transmission Reliability Data (Years 2013 – 2017)**

Transmission Outages (last 5 Years)							SAIDI	SAIFI	CAIDI
Line Section	Momentary	Sustained	Total Sustained Outages	Total Duration (min)	Customers	CMI			
Krain Corner - WR Mill	13*	7	7	949	1	949	190	1.4	136
WR Mill - Clay Creek		12	19	4,173	8	33,384	835	3.8	220
Clay Creek - Greenwater		10	29	8,163	888	7,248,744	1,633	5.8	281

\*Updated protection to mitigate power quality issues results in momentary outages being sustained for Clay Creek - Greenwater Effective approximately 5/2015

The analysis shows that there are some substantial reliability problems on the Greenwater Tap. The number and duration of the sustained interruptions for the last 5 years is quite large. Interestingly, the number of sustained interruptions for the WWR – Clay Creek and Clay Creek – Greenwater line sections is similar (12 vs 10), though the total duration of the interruptions is very different (4,173 minutes vs 8,163 minutes). The Clay Creek – Greenwater section is mostly on the forest road with minimal access, resulting in increased time to locate, determine cause, and resolve the issue. While the transmission line outages themselves are an issue, the ability to see and patrol the line from a major access point has significant benefits with respect to the duration of the interruption and the overall impact of transmission outages to the customers. During storm conditions, the access and ability to patrol this section of the transmission system is extremely difficult and presents safety concerns.

Classification: Sensitive

*This document contains Critical Energy Infrastructure Information (CEII)*

*The use or disclosure of which is protected.*

**Enumclaw – Greenwater – Needs Assessment**

After substantial completion of this report, a more recent review of the Transmission Reliability was performed, which analyzed outages in the five-year timeline from 2015-2019. In this timeframe, the Greenwater Tap had the highest Non-Storm CMI of any Transmission Line in PSE’s territory.

Table 7-2 below shows the performance of the Greenwater Tap compared to the average PSE transmission line.

**Table 7-2: Greenwater Transmission Reliability Data (2015-2019)**

<b>Reliability Metric (2015-2019)</b>	<b>PSE Average<sup>2</sup></b>	<b>Greenwater Tap (% of Average)</b>
<b>Non-MED Outages</b>	4.93	24 (487%)
<b>Non-MED Sustained Outages</b>	3.04	20 (658%)
<b>Non-MED Customer Interruptions</b>	10,397	33,272 (320%)
<b>Non-MED Customer Minute Interruptions</b>	1,104,486	6,046,422 (547%)
<b>All-In Customer Interruptions</b>	15,441	46,532 (301%)
<b>All-In Customer Minute Interruptions</b>	3,612,873	13,024,189 (360%)

This analysis shows that the Greenwater Tap continues to have reliability that is significantly worse than average for PSE transmission lines. There is a need to improve both the reliability and storm resiliency for customers in the area.

**7.1.1 Power Quality**

There is a documented, reoccurring power quality issue for the customers on the Greenwater Tap. There is approximately 9 miles of 12.5 kV distribution circuit underbuilt on the Greenwater Tap transmission line. Tree damage has caused the transmission lines to fall into the distribution system, resulting in a high voltage surge on the distribution system, affecting the voltage that is served to customers and damaging equipment. To date there have been 74 customer claims and numerous customer meetings about this continued issue. To mitigate some of the issue, reclosing for momentary faults at Clay Creek has been turned off. This means any momentary fault on the Greenwater Tap results in a sustained outage from Clay Creek towards Greenwater. Approximately 9 miles of transmission line going East from Clay Creek Substation to Greenwater substation have distribution underbuild that could result in these power quality issues. This affects approximately 128 transmission poles on this line section. Several of the poles in the area have been rebuilt to attempt to provide further separation between the transmission and distribution lines. There have been minimal, if any, power quality issues since the work was completed, but this issue is still a concern for the area.

<sup>2</sup>The PSE Average values were calculated using 2015-2019 data for all transmission lines in PSE territory.

Classification: Sensitive

*This document contains Critical Energy Infrastructure Information (CEII)*

*The use or disclosure of which is protected.*

## Enumclaw – Greenwater – Needs Assessment

## 8 3700 Forest Road Transmission Route Issues

The map below (Figure 8-1) shows the entire Greenwater Tap (in blue) within the orange circle. Beyond the Clay Creek substation, the Greenwater Tap line crosses the White River and goes along a route known as 3700 Forest Road (shown within the yellow circle).

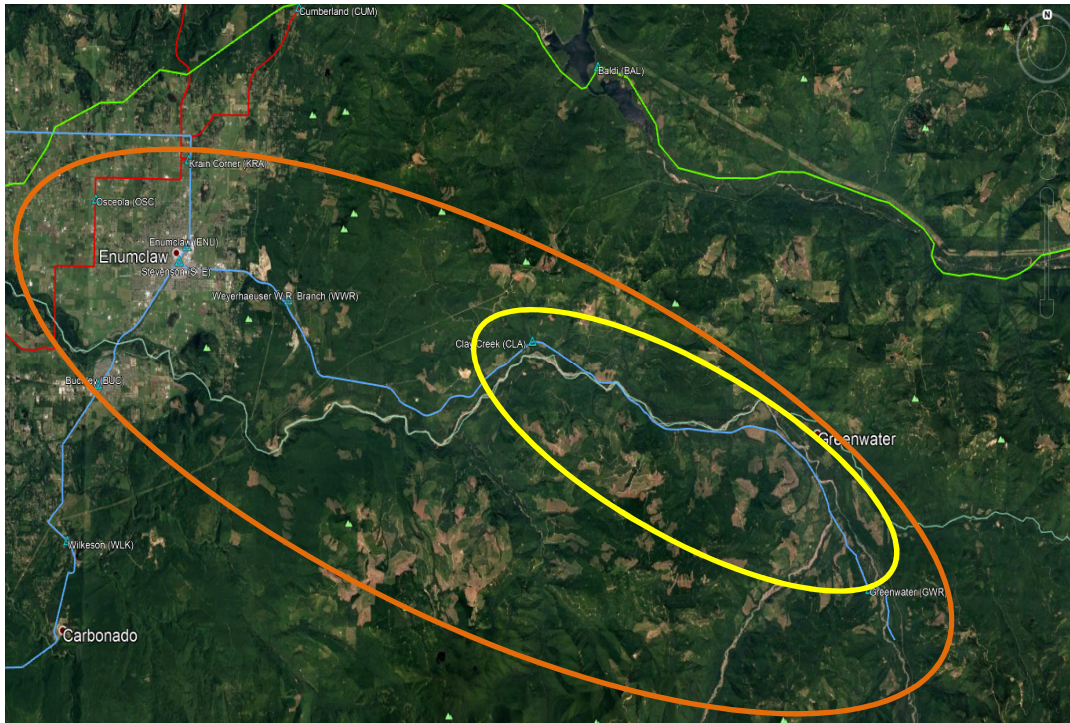

**Figure 8-1: Greenwater Tap – Forest Road 3700**

While the name of the road implies that the land is on forest land, the land is owned by the Muckleshoot Indian Tribe and is under management by the Hancock Natural Resource Group. The land was purchased by the Muckleshoot Tribe in December of 2013 from the Hancock group. Figure 8-2 shows the land that was purchased as part of the sale in 2013. It is important to note that the tribe now owns significant portions of the land on both sides of Highway 410, where the Greenwater Tap resides.

Classification: Sensitive

*This document contains Critical Energy Infrastructure Information (CEII)  
The use or disclosure of which is protected.*

**Enumclaw – Greenwater – Needs Assessment****Figure 8-2: Muckleshoot Land Purchase (Seattle Times)****8.1.1 Easements for Right of Way**

After PSE's legal review of existing easements along the 3700 Forest Road on Muckleshoot Federal property, it was determined that PSE does not have access rights to the existing system which extends for 9 miles. The easement was established using the forestry roads as access and now many of the roads have been or are slated for decommissioning to allow the White River to meander more naturally and thus providing improved habitat. Should the 3700 Forest Road wash away or experience a mass wasting event, PSE has no rights to restore 3700 Forest Road or create a new temporary or permanent access way.

**8.1.2 Channel Migration Zone**

Several sections of the 3700 Forest Road are located in the Channel Migration Zone (CMZ) of the White River. Much of the existing system is at risk of being inaccessible and may no longer be a viable route for the utility corridor. The Muckleshoot Federal Corporation (new property owner of the forest road as mentioned above) has prioritized the White River areas to meet their fish and wildlife habitat needs, which does not include utility infrastructure and associated access roads, or the scheduled vegetation clearing or maintenance associated with transmission lines. There are two main areas where the CMZ affects that transmission line on 3700 Forest Road. The first area (Area 1), is south of the Federation Forest State Park. This affected section is almost 1.6 miles long and has sections where the poles have previously been moved / relocated due to CMZ issues. The second area (Area 2), is near the town of Greenwater. The affected area is almost 0.75 miles long. The location of the two CMZ areas are shown below in Figure 8-3.

Classification: Sensitive

*This document contains Critical Energy Infrastructure Information (CEII)  
The use or disclosure of which is protected.*

## Enumclaw – Greenwater – Needs Assessment

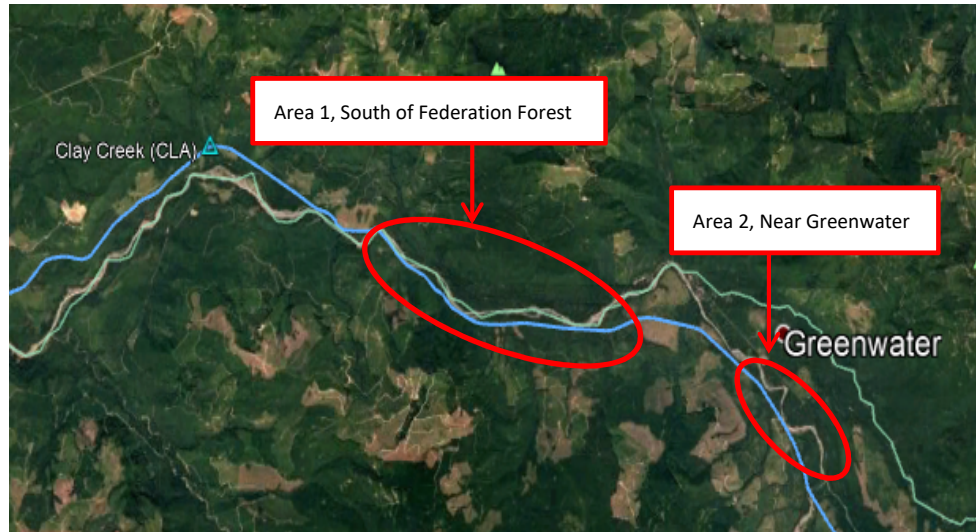

**Figure 8-3: Aerial view of Greenwater Tap, CMZ Areas**

The CMZ affects approximately 3 miles of the existing transmission corridor and roughly 70 transmission structures. Not only could we lose road access but these structures are in danger of being completely washed away, as the poles are wood with standard direct embedment in native soil or gravel backfill. Structures in this area have been washed out in the past. To keep the structures in the CMZ would require further analysis into mitigation options such as steel structures, foundation types, access, constructability, and future maintenance. Regardless of whether these sections stay in the CMZ or are rerouted they would end up being completely rebuilt. Additionally, staying in the CMZ could delay the permitting process and environmental studies for future work or moving out of the CMZ may be required.

Figure 8-4 shows the details of the CMZ impact for Area 1, South of Federation Forest.

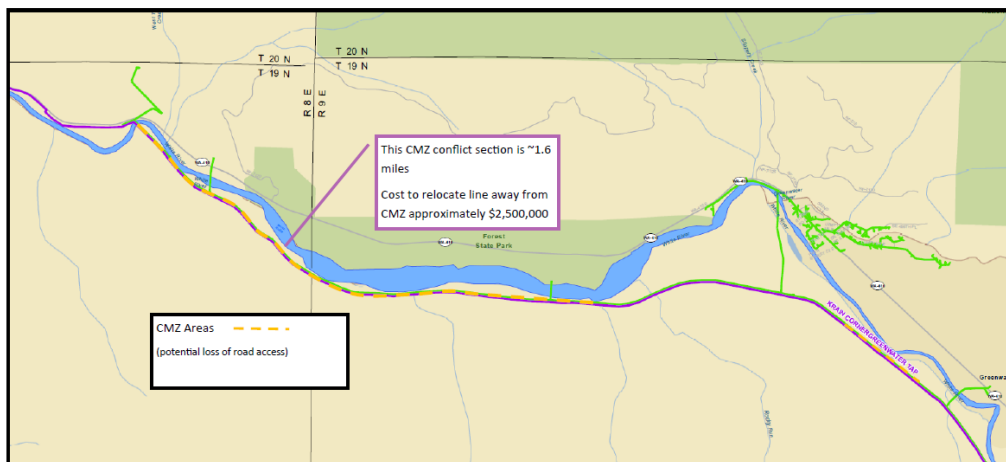

**Figure 8-4: Area 1, South of Federation Forest Park**

Classification: Sensitive

*This document contains Critical Energy Infrastructure Information (CEII)  
The use or disclosure of which is protected.*

**Enumclaw – Greenwater – Needs Assessment**

Figure 8-5 shows the details of the CMZ impact for Area 2, near Greenwater.

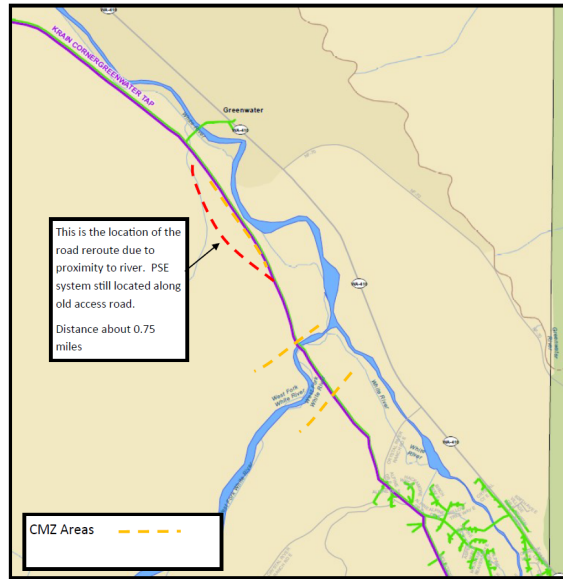

**Figure 8-5: Area 2, Near Greenwater**

Classification: Sensitive

*This document contains Critical Energy Infrastructure Information (CEII)  
The use or disclosure of which is protected.*



**Enumclaw – Greenwater – Needs Assessment**

---

## 9 Conclusions on Needs Assessment

---

The preceding sections demonstrate that there are needs and concerns for improvements for the Enumclaw – Greenwater area, including reliability needs, easement risks, obsolete infrastructure, and operational concerns.

The 55 kV transformer at Krain Corner does not have a spare and presents a significant risk to the customers for an outage of the transformer.

Concurrent studies in the area have identified separate needs that should be considered when solutions are determined. The transmission needs include the need to serve customers on the Greenwater Tap via an alternative source instead of Forest Road 3700, and the need to increase reliability and power quality on the transmission line section between Clay Creek and the Greenwater substation.

---

### 9.1 Statement of Needs and Concerns

---

The Enumclaw - Greenwater Reliability Needs Assessment confirmed that there are several existing needs and concerns in the area.

**Needs:**

- **Transmission Reliability:** The location of the transmission line along Forest Road 3700 Right Of Way (FR 3700 ROW) has a strong impact on the reliability of the line. There are numerous tree-related outages that have extended restoration time due to the length of time required to patrol the line and resolve the cause of the outage. The number and duration of the sustained outages from 2015-2019 are over 300% larger than average PSE transmission lines.
- **Land Rights Issues:** PSE lacks sufficient land rights along 9 miles of FR 3700 ROW on the Greenwater Tap transmission path.
- **Channel Migration Zone (CMZ):** Several transmission poles of the Greenwater Tap were identified as at risk of being washed away since they are within the Channel Migration Zone (CMZ) of the White River.

**Concerns**

- **Obsolete Infrastructure:** The Greenwater Tap is a 55 kV transmission supply in south King County. The 55 kV voltage level has limited footprint remaining in the PSE service area, and long term PSE plans include converting the remaining 55 kV voltage level system to PSE's current standard voltages. The spares for the Krain Corner 115 kV/55 kV three phase transformer are almost 60 years old and may not be reliable. A loss of the Krain Corner 115 kV/55 kV transformer will result in significant issues in serving the load on the 55 kV system.
- **Power Quality:** There have been several customer claims due to Power Quality issues when the 55kV Transmission has contacted 12.47kV Distribution and caused equipment failures.
- **Operational Flexibility:** The Greenwater Tap is fed radially from the Krain Corner substation. The alternate source from Electron Heights is being converted to 115kV and

Classification: Sensitive

*This document contains Critical Energy Infrastructure Information (CEII)*

*The use or disclosure of which is protected.*

**Enumclaw – Greenwater – Needs Assessment**

will not be a viable switching option. Krain Corner currently has a Main-Bus Only configuration and requires de-energizing the Greenwater Tap line for maintenance of substation or line equipment.

- **Storm Resiliency:** The Greenwater Tap serves a remote area at the outer edge of PSE's electric system. This area experiences outages with longer than average durations due to safety, access, and weather conditions.

Classification: Sensitive

*This document contains Critical Energy Infrastructure Information (CEII)  
The use or disclosure of which is protected.*

## Enumclaw – Greenwater – Needs Assessment

**Appendix A Glossary**

<b>Term</b>	<b>Definition</b>
Block load	A large expected increase in electric energy demand from an existing or new customer.
Circuit	A circuit is the electric equipment associated with serving all customers under normal configuration from a specific distribution circuit breaker at a substation.
CMI- Customer Minute Interruptions	CMI is the total combined minutes interrupted due to an outage. CMI is commonly used as a reliability indicator by electric power utilities.
Concern	A “concern” is a non-critical issue that impacts system operations but is <u>not</u> required to be addressed by a solution; a solution that addresses an identified concern provides additional benefit.
Conservation	Measures to improve efficiency of customer’s electric loads reducing energy use and reducing peak demand.
Consumption	Consumption is the amount of electricity that customers use over the course of a year and it’s measured in kilowatt hours.
Contingency	Contingencies are a set of transmission system failure modes, when elements are taken out of service (e.g., loss of equipment).
Corrective Action Plan	A Corrective Action Plan (CAP) is a solution to address transmission system deficiencies and meet performance requirements. A CAP may include system upgrades such as planned projects, topology modifications or operational plans to radially operate the system, run generation or even implement load shedding.
Curtable	A load that may be interrupted to reduce load on system during peak periods. Curtable customers are on a different rate schedule than non-curtable (firm) customers.
Demand	The amount of power being required by customers at any given moment, and it’s measured in kilowatts.
DR- Demand response	Flexible, price-responsive loads, which may be curtailed or interrupted during system emergencies or when wholesale market prices exceed the utility’s supply cost. Demand response is also the voluntary reduction of electricity demand during periods of peak electricity demand or high electricity prices. Demand response provides incentives to customers to temporarily lower their demand at a specific time in exchange for reduced energy costs.
Distributed generation	Small-scale electricity generators, like rooftop solar panels, located close to the source of the customer’s load.

Classification: Sensitive

*This document contains Critical Energy Infrastructure Information (CEII)  
The use or disclosure of which is protected.*

## Enumclaw – Greenwater – Needs Assessment

Term	Definition
Distribution line	A distribution line is a medium-voltage (12.5 kV-35 kV) line that carries electricity from a substation to customers. Roughly half of PSE's distribution lines are underground. Distribution voltage is stepped down to service voltage through smaller transformers located along distribution lines. Distribution lines differ from feeder as it includes the large feeder wire and smaller wire laterals.
Distribution System	A distribution system is the medium-voltage (12.5 kV-35 kV) infrastructure that carries electricity from a substation to customers and includes the substation transformer. System is the collective of all of this infrastructure in an entire study area.
EPRI- The Electric Power Research Institute	The Electric Power Research Institute conducts research, development, and demonstration projects for the benefit of the public in the United States and internationally. As an independent, nonprofit organization for public interest energy and environmental research, they focus on electricity generation, delivery, and use.
Feeder	A feeder is the largest conductor section of a circuit and generally
Institute of Electrical and Electronics Engineers (IEEE)	A professional association, promoting the development and application of electro-technology and allied sciences for the benefit of humanity, the advancement of the profession, and the well-being of our members.
Integrated Resource Plan (IRP)	The Integrated Resource Plan (IRP) is a forecast of conservation resources and supply-side resource additions that appear to be cost effective to meet the growing needs of our customers over the next 20 years. Every two years, utilities are required to update integrated resource plans to reflect changing needs and available information.
Interim Operating Plan (IOP)	A temporary plan to address a transmission system deficiency and meet performance requirements, until a solution takes effect. An IOP may consist of a series of operational steps to radially operate the system, run generation or implement load shedding.
Kilovolt (kV)	A kilovolt (kV) is equal to 1,000 volts of electric energy. PSE uses kilovolts as a standard measurement when discussing things like distribution lines and the energy that reaches our customers.
Load	The total of customer demand plus planning margins and operating reserve obligations.
Load forecast	A load forecast is a projection of how much power PSE's customers will use in future years. The forecast allows PSE to plan upgrades to its electric system to ensure that current and future customers continue to have reliable power. Federal regulations require that utilities plan a reliable system based on forecasted loads. When developing a load forecast, PSE takes multiple factors into account like current loads, economic and population projections, building permits, conservation goals, and weather events.

Classification: Sensitive

*This document contains Critical Energy Infrastructure Information (CEII)  
The use or disclosure of which is protected.*

## Enumclaw – Greenwater – Needs Assessment

Term	Definition
Load shedding	Load shedding is when a utility intentionally causes outages to customers because demand for electricity is exceeding the capacity of the electric grid. Load shedding is the option of last resort and is conducted to protect the integrity of the electric grid components in order to avoid a larger blackout. This is not a practice that PSE endorses as a long-term solution to meet mandatory performance requirements.
Major Event Day (MED)	Any day in which the daily system SAIDI exceeds the annual threshold value. Outages on those days are excluded from the SAIDI performance calculation.
Megawatt (MW)	A megawatt (MW) is equal to 1,000,000 watts of electric energy. PSE uses megawatts as a standard measurement when discussing things like system load and peak demand. MW differs from MVA in that it is generally always lower and translates as energy that performs work. The amount of MW vs MVA is determined by load characteristics. Motor loads generally have a lower power factor (PF) than heating loads for example and as a result. $MW = MVA * PF$
Mega Volt-Amp (MVA)	A MVA is equal to 1,000,000 (Volt*Amps). MVA is generally slightly higher than MW. Equipment ratings are in MVA as the equipment heat rise is determined by actual MVA.
N-0	This is a planning term describing that the electric grid is operating in a normal condition and no components have failed.
N-1	This is a planning term describing an outage condition when one system component has failed or has been taken out of service for construction or maintenance.
N-1-1	This is a planning term describing outage conditions where two failures occur one after another with a time delay between them.
N-2	This is a planning term describing outage conditions where two failures occur nearly simultaneously.
Native Load Growth	Load growth associated with existing customers or new customers less than 1 MW.
Need	A constraint or limitation on the delivery system in providing safe and reliable electric supply to customers. A need is a “must-have” that is required to be addressed for the system in a timely manner (by a certain Need Date, as determined in a needs assessment)
Non-wires alternatives	Alternatives that are not traditional poles, wires and substations. These alternatives can include demand reduction technologies, battery energy storage systems, and distributed generation.

Classification: Sensitive

*This document contains Critical Energy Infrastructure Information (CEII)  
The use or disclosure of which is protected.*

## Enumclaw – Greenwater – Needs Assessment

Term	Definition
NERC- North American Electric Reliability Corporation	NERC establishes the reliability standards for the North American grid.  NERC is a not-for-profit international regulatory authority whose mission is to ensure the reliability of the bulk power system in North America, as certified by FERC. NERC develops and enforces Reliability Standards and annually assesses seasonal and long-term reliability. PSE is required to meet the Reliability Standards and is subject to fines if noncompliant.
Peak demand	Customers' highest demand for electricity at any given time, and it's measured in megawatts.
Proven technology	Technology that has successfully operated with acceptable performance and reliability within a set of predefined criteria. It has a documented track record for a defined environment, meaning there are multiple examples of installations with a history of reliable operations. Such documentation shall provide confidence in the technology from practical operations, with respect to the ability of the technology to meet the specified requirements.
Reasonable project cost	Reasonable project cost means holistically comparing costs and benefits to project alternatives. This includes dollar costs, as well as duration of the solution, risk to the electric system associated with the type of solution (e.g., is the solution an untested technology), and impacts to the community.
Right of way	A corridor of land on which electric lines may be located. PSE may own the land in fee, own an easement, or have certain franchise, prescription, or license rights to construct and maintain lines.
Sensitivities	Sensitivities are circumstances or stressors under which the contingencies are tested (e.g., forecasted demand levels, interchange, various generation configurations).
Substation	A substation is a vital component of electricity distribution systems, containing utility circuit protection, voltage regulation and equipment that steps down higher-voltage electricity to a lower voltage before reaching your home or business.
Substation group	A grouping of 2-5 substation transformers that are situated close enough to each other that loads in the study area can be switched from one station to an adjacent station for maintenance, construction, or permanent load shifting.
Substation group capacity	The aggregate distribution transformer capacity of the substation group for winter and summer rating, calculated in MVA.
SAIDI- System Average Interruption Duration Index	SAIDI is the length of non-major-storm power outages per year, per customer. SAIDI is commonly used as a reliability indicator by electric power utilities. Outages longer than 5 minutes are included.

Classification: Sensitive

*This document contains Critical Energy Infrastructure Information (CEII)  
The use or disclosure of which is protected.*

**Enumclaw – Greenwater – Needs Assessment**

<b>Term</b>	<b>Definition</b>
SAIFI- System Average Interruption Frequency Index	SAIFI is the frequency of non-major-storm power outages per year, per customer. SAIFI is commonly used as a reliability indicator by electric power utilities. Interruptions longer than 1 minute are included.
Transformer	A transformer is a device that steps electricity voltage down from a higher voltage, or steps it up to a higher voltage, depending on use. On the distribution system, transformers typically step the voltage down from a distribution voltage (12.5 kV) to 120 to 240 volts for customers' residential use. Transformers are the green boxes in some residences' front yard or the barrel-like canisters on utility poles.
Transmission line	Transmission lines are high-voltage lines that carry electricity from generation plants to substations or from substation to substation. Transformers at the substation "step down" the electricity's transmission voltage (55 to 230 kilovolts) to our primary distribution voltage (12.5 kV).

Classification: Sensitive

*This document contains Critical Energy Infrastructure Information (CEII)  
The use or disclosure of which is protected.*

Enumclaw – Greenwater – Needs Assessment

## Appendix B One-Line Diagrams

### A.1 – Existing One-Line Diagram

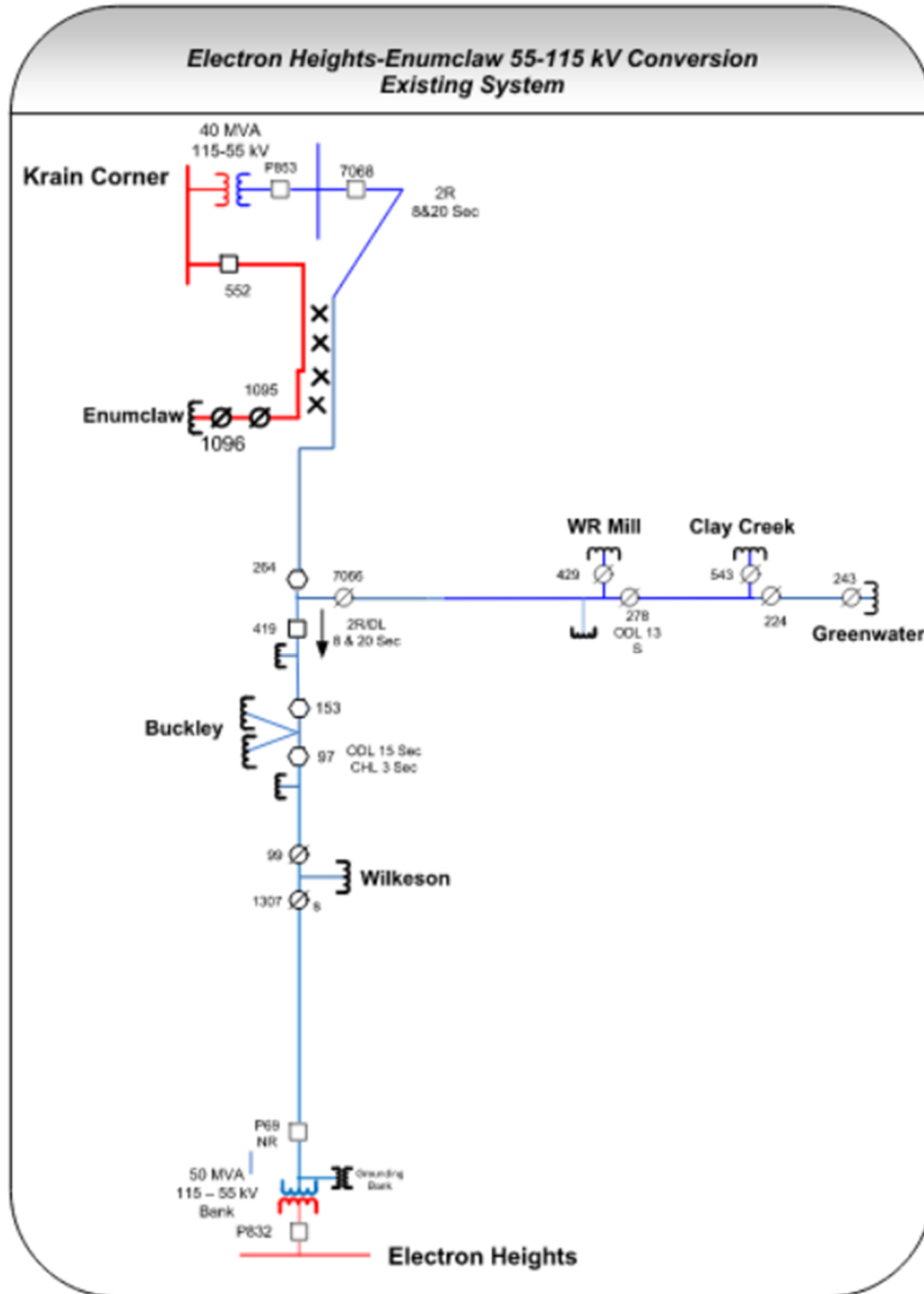

Classification: Sensitive

*This document contains Critical Energy Infrastructure Information (CEII)  
The use or disclosure of which is protected.*



Enumclaw – Greenwater – Needs Assessment

**A.2 – Proposed One-Line Diagram**

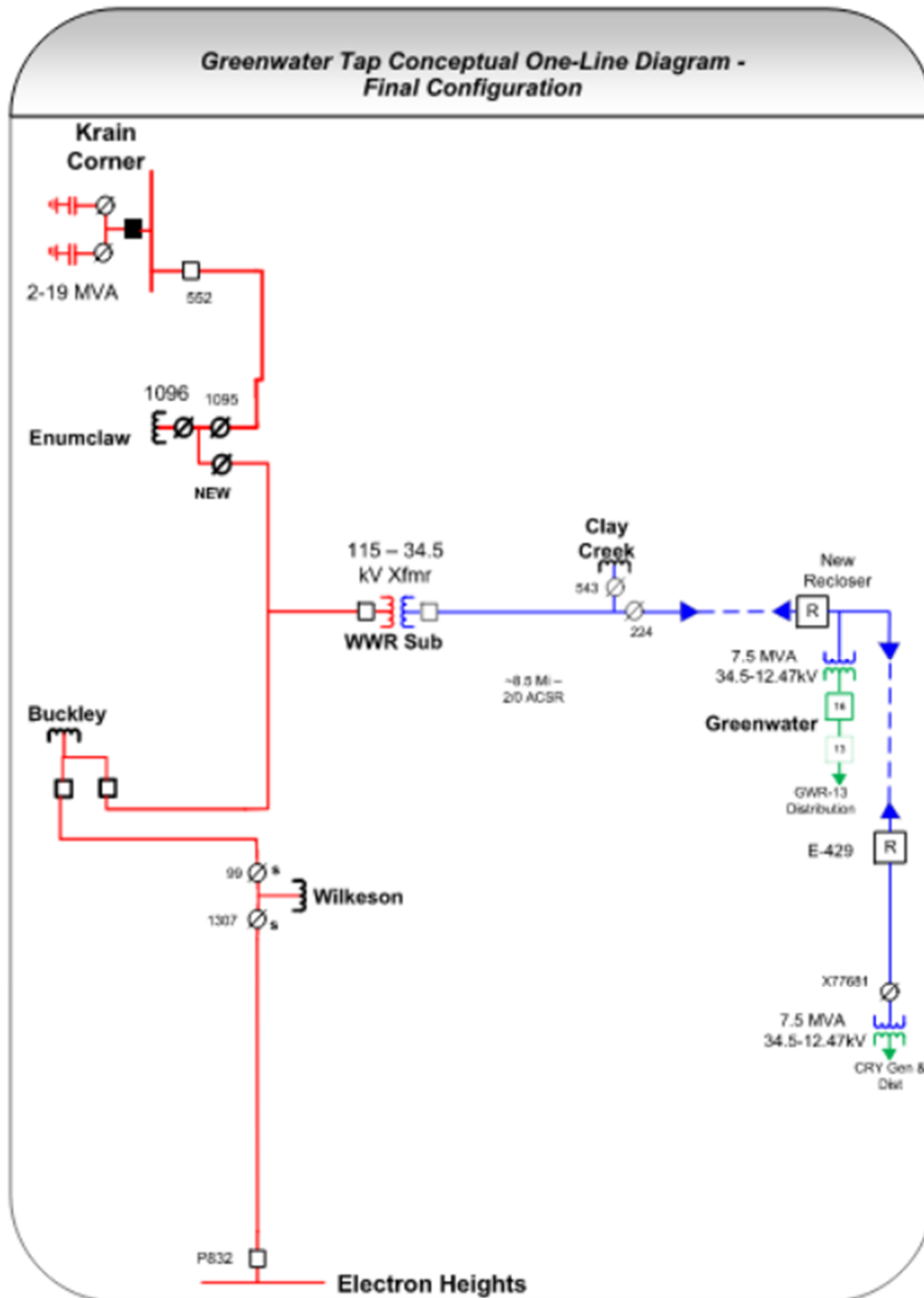

Classification: Sensitive  
This document contains Critical Energy Infrastructure Information (CEII)  
The use or disclosure of which is protected.



# Enumclaw - Greenwater Electric System Solutions Report



Mt. Rainier from Crystal Mountain

## Strategic System Planning August, 2023

Classification: Sensitive

*This document contains Critical Energy Infrastructure Information (CEII),  
the use or disclosure of which is protected.*



# Enumclaw - Greenwater Electric System Solutions Report

## Prepared By:

Colin O'Brien, PE, *Strategic System Planning*  
David Meyer, PE, *PSE*

## Reviewed By:

Rachit Arora, PE, *Strategic System Planning*  
Eleanor Ewry, PE, *Strategic System Planning*

## Approved By:

DocuSigned by:  
*Ryan Lambert*  
48EEB5A77F87404...

08/30/2023

---

*Ryan Lambert*  
*System Planning, Manager*

*Date*

DocuSigned by:  
*David Landers*  
B6002897FD5542C...

09/11/2023

---

*David Landers*  
*System Planning, Director*

*Date*

## Strategic System Planning August, 2023

Classification: Sensitive

*This document contains Critical Energy Infrastructure Information (CEII),  
the use or disclosure of which is protected.*

---

## Table of Contents

---

Table of Contents.....	3
List of Figures .....	4
List of Tables .....	5
Executive Summary.....	6
1.1 Enumclaw – Greenwater Area Needs.....	7
1.2 Alternatives Analyzed .....	8
1.3 Preferred Wires Solution for Improving Enumclaw - Greenwater Reliability.....	10
1 Introduction, Methodology and Key Assumptions .....	12
1.1 Methodology.....	12
1.2 Solution Criteria .....	13
1.3 Study Assumptions.....	15
2 Needs Summary .....	16
2.1 Needs and Concerns .....	16
3 Wires Alternatives.....	17
3.1 No Action Alternative.....	17
3.2 Alternative 1: 115kV to Greenwater.....	17
3.3 Alternative 2: 115kV to Clay Creek, 35kV to Greenwater.....	18
3.4 Alternative 3: 115kV to Weyerhaeuser White River, 35kV to Greenwater .....	19
3.5 Alternative 4: 35kV from Krain Corner to Greenwater.....	20
4 Non-Wires Alternatives.....	22
4.1 Guidehouse Consulting Analysis .....	22
4.2 Non-Wires Alternatives.....	22
4.3 Non-Wire Analysis Conclusion .....	23
5 Comparison of Alternatives .....	24
5.1 Decision Factors – Qualitative Analysis .....	24
6 Preferred Solution.....	26
Appendix A Glossary.....	29

Classification: Sensitive

*This document contains Critical Energy Infrastructure Information (CEII),  
the use or disclosure of which is protected.*

---

## List of Figures

---

Figure 0-1. Greenwater Tap Transmission Overview .....	6
Figure 0-2. Wires Alternatives Cost vs. Benefit Summary .....	8
Figure 0-3: Proposed Solution .....	11
Figure 1-1: PSE Solutions Study Methodology.....	13
Figure 4-1. Guidehouse NWA Process .....	22
Figure 6-1. Preferred Solution - Overall.....	26
Figure 6-2. Preferred Alternative - Phase 1 Scope.....	27
Figure 6-3. Preferred Alternative - Phase 2 Scope.....	28

Classification: Sensitive

*This document contains Critical Energy Infrastructure Information (CEII),  
the use or disclosure of which is protected.*

---

## List of Tables

---

Table 0-1: Summary of Top non-wire Alternatives .....	9
Table 2-1: Greenwater Area Needs and Concerns Summary .....	16
Table 3-1. Alternative 1 Needs and Concerns Analysis.....	18
Table 3-2. Alternative 2 Needs and Concerns Analysis.....	19
Table 3-3. Alternative 3 Needs and Concerns Analysis.....	20
Table 3-4. Alternative 4 Needs and Concerns Analysis.....	21
Table 4-1. NWA Alternative Comparison.....	23
Table 5-1. Wires Alternative Comparison.....	24
Table 5-2. Qualitative Analysis - Benefits and Risks .....	25

Classification: Sensitive

*This document contains Critical Energy Infrastructure Information (CEII),  
the use or disclosure of which is protected.*

## Executive Summary

After completion of the Enumclaw - Greenwater Needs Assessment, Puget Sound Energy (PSE) and industry experts conducted analyses of traditional wires alternatives (wires) and non-wires alternatives (NWA) to determine a cost-effective solution that addresses the identified system needs for the Greenwater Tap over the 10-year planning horizon. This approach allows PSE to meet customer needs and expectations, while gaining experience implementing new technologies as tools to address system needs where prudent.

The Greenwater Tap is a 26-mile long radial 55 kV transmission line originating from the Krain Corner 115 kV substation. The Greenwater Tap serves multiple substations and several rural communities to its termination at the Greenwater Substation, just past the town of Greenwater along State Highway 410. Figure 0-1 below shows an overview of the Greenwater Tap transmission line from Krain Corner to Greenwater.

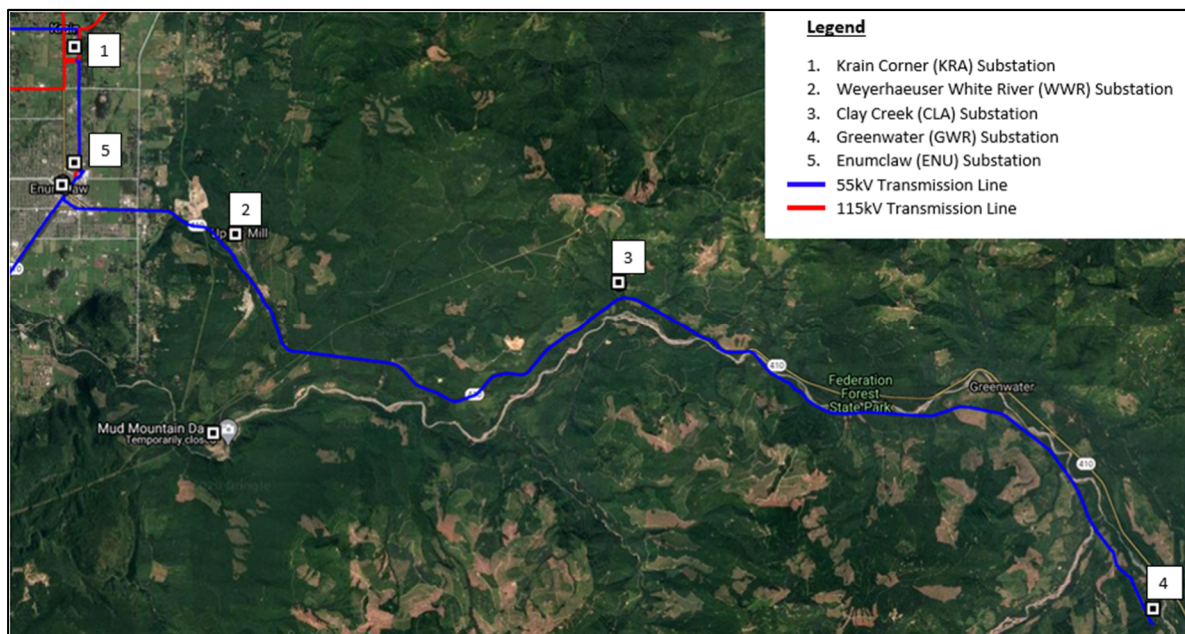

**Figure 0-1. Greenwater Tap Transmission Overview**

PSE's System Planning department regularly assesses electrical system needs to ensure PSE can reliably serve residents and businesses over a 10-year planning horizon. The Enumclaw - Greenwater Needs Assessment determined that the Greenwater Tap transmission line has reliability and land rights needs, along with various concerns during the 10-year planning horizon.

Classification: Sensitive

*This document contains Critical Energy Infrastructure Information (CEII),  
the use or disclosure of which is protected.*

## 1.1 Enumclaw – Greenwater Area Needs

---

The Enumclaw – Greenwater Area Needs Assessment report identified needs and concerns<sup>1</sup> for PSE’s transmission and distribution system, which are briefly described below. See Figure 0-2 for a summary of all needs and concerns.

### Needs:

- **Transmission Reliability:** The location of the transmission line along Forest Road 3700 Right Of Way (FR 3700 ROW) has a strong impact on the reliability of the line. There are numerous tree-related outages that have extended restoration time due to the length of time required to patrol the line and resolve the cause of the outage. The number and duration of the sustained outages from 2015-2019 are over 300% larger than average PSE transmission lines.
- **Land Rights Issues:** PSE lacks sufficient land rights along 9 miles of FR 3700 ROW on the Greenwater Tap transmission path.
- **Channel Migration Zone (CMZ):** Several transmission poles of the Greenwater Tap were identified as at risk of being washed away since they are within the Channel Migration Zone (CMZ) of the White River.

### Concerns

- **Obsolete Infrastructure:** The Greenwater Tap is a 55 kV transmission supply in south King County. The 55 kV voltage level has limited footprint remaining in the PSE service area, and long-term PSE plans include converting the remaining 55 kV voltage level system to PSE’s current standard voltages. The spares for the Krain Corner 115 kV/55 kV three phase transformer are almost 60 years old and may not be reliable. A loss of the Krain Corner 115 kV/55 kV transformer will result in significant issues in serving the load on the 55 kV system.
- **Power Quality:** There have been several customer claims due to Power Quality issues when the 55kV Transmission has contacted 12.47kV Distribution and caused equipment failures.
- **Operational Flexibility:** The Greenwater Tap is fed radially from the Krain Corner substation. The alternate source from Electron Heights is being converted to 115kV and will not be a viable switching option. Krain Corner currently has a Main-Bus Only configuration and requires de-energizing the Greenwater Tap line for maintenance of substation or line equipment.

---

<sup>1</sup> PSE defines “need” as a system deficiency that is required to be addressed by a solution, preferably by the identified date of need.

A “concern” is a non-critical issue that impacts system operations but is not required to be addressed by a solution; a solution that addresses an identified concern provides additional benefit.

Classification: Sensitive

*This document contains Critical Energy Infrastructure Information (CEII),  
the use or disclosure of which is protected.*



- Storm Resiliency:** The Greenwater Tap serves a remote area at the outer edge of PSE’s electric system. This area experiences outages with longer than average durations due to safety, access, and weather conditions.

## 1.2 Alternatives Analyzed

PSE, along with industry partners, studied various alternatives for meeting the needs identified for the Enumclaw - Greenwater transmission system. This Solutions report details conventional wires and non-wires alternatives considered to solve the aforementioned needs and concerns. Various alternatives were screened for viability using the solution criteria detailed in Section 1.2.

PSE studied conventional wires, non-wires alternatives (NWA), and hybrids of wires and non-wires alternatives. The goal of the analyses was to consider the technical and economic feasibility of potential alternatives which could meet the Greenwater area solution criteria.

PSE studied various wires alternatives, and determined the top wires alternatives to include:

- No Action Alternative**
- Alternative 1:** 115kV Conversion from Krain Corner to Greenwater
- Alternative 2:** 115kV Conversion from Krain Corner to Clay Creek and 35kV Conversion to Greenwater
- Alternative 3:** 115kV Conversion from Krain Corner to Weyerhaeuser White River and 35kV Conversion to Greenwater
- Alternative 4:** 35kV Conversion from Krain Corner to Greenwater

The following chart shows an overview of the viability of each wires alternative and the cost vs. benefit comparison:

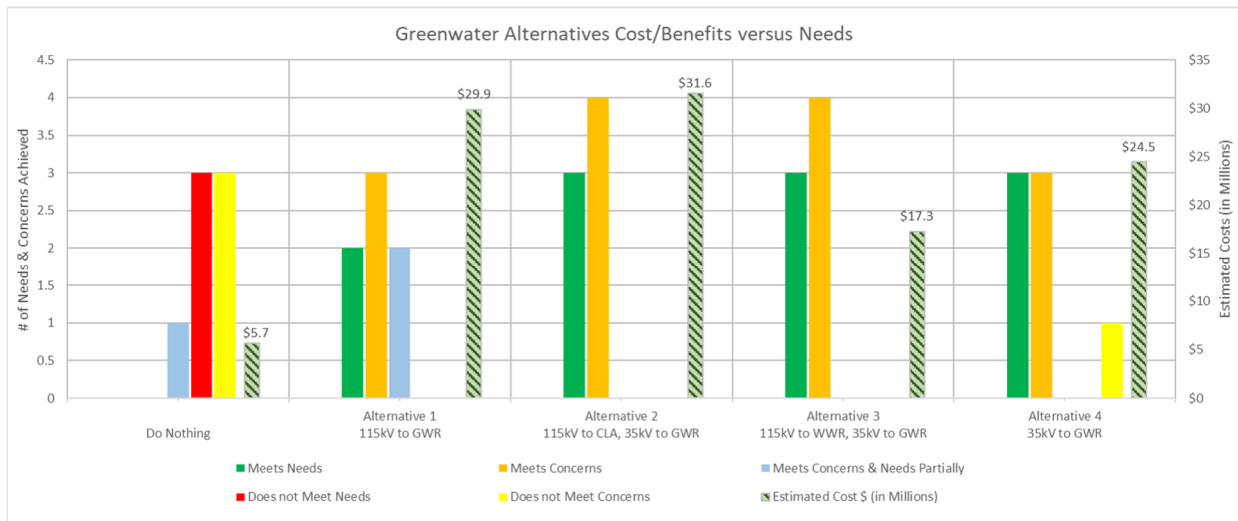

**Figure 0-2. Wires Alternatives Cost vs. Benefit Summary**

PSE considered a non-wires alternative consisting of both battery energy storage and distributed energy resources (DERs). A DER is defined as “a resource sited close to customers that can provide all or some of their immediate electric and power needs and can also be used by the system to reduce system

Classification: Sensitive

*This document contains Critical Energy Infrastructure Information (CEII),  
the use or disclosure of which is protected.*

demand (such as energy efficiency) or provide supply to satisfy the energy, capacity, or ancillary service needs of the distribution grid. The resources, if providing electricity or thermal energy, are small in scale, connected to the distribution system, and close to load".<sup>2</sup> PSE also considered a hybrid alternative consisting of Phase 1 of the preferred wires alternatives in conjunction with selected non-wires alternatives to defer aspects of Phase 2 of the preferred wires alternative.

Due to the needs identified for the Greenwater Tap, it was determined that feasible NWA solutions are limited to fully islanded microgrids. The top non-wires and hybrid alternatives include:

- Large Battery Case – Solar plus storage microgrid
- Large Solar Case – Solar plus storage microgrid

<b>Component</b>	<b>Large Solar Case</b>	<b>Large Battery Case</b>
PV Cost Estimate (\$M/MW DC)	\$1.0	\$1.0
Installed PV Capacity (MW DC)	85.0	10.0
ESS per MW Cost Estimate (\$M/MW)	\$0.31194	\$0.31194
ESS per MWh Cost Estimate (\$M/MWh)	\$0.30844	\$0.30844
ESS Efficiency (%)	90%	90%
ESS Need (MW)	64.2	8.1
ESS Duration (hours)	13.9	1898.1
ESS Size (MWh)	892.6	15,313.8
Demand Side Management Cost Estimate (\$M)	\$0.0	\$0.0
PV Cost Estimate (\$M)	\$85.0	\$10.0
ESS Cost Estimate (\$M)	\$295.3	\$4,725.9
<b>NWA Portfolio Cost Estimate (\$M)</b>	<b>\$380.3</b>	<b>\$4,735.9</b>

Source: Guidehouse analysis

**Table 0-1: Summary of Top non-wire Alternatives<sup>3 4</sup>**

In addition to the significant upfront cost of the non-wires alternatives making these solutions cost prohibitive, Guidehouse found that these alternatives would only serve as a stopgap measure and would be technically infeasible due to winter peaking loads on the Greenwater Tap<sup>5</sup>.

Overall, the non-wires analysis concluded there are no cost-effective Non-Wires options that can meet the needs identified on the Greenwater Tap.

<sup>2</sup> National Association of Regulatory Utility Commissioners. "NARUC Manual on Distributed Energy Resources Rate Design and Compensation." November 2016. <http://pubs.naruc.org/pub/19FDF48B-AA57-5160-DBA1-BE2E9C2F7EA0>

<sup>3</sup> Costs are estimate based on similar past projects in other areas of PSE service territory. Does not include site-specific engineering.

<sup>4</sup> The costs shown for the wires portions of all alternatives are capital investment costs.

<sup>5</sup> Greenwater NWA Final Report, Guidehouse Consulting, Page 1.

Classification: Sensitive

*This document contains Critical Energy Infrastructure Information (CEII),  
the use or disclosure of which is protected.*

### **1.3 Preferred Wires Solution for Improving Enumclaw - Greenwater Reliability**

PSE determined the preferred solution that cost-effectively meets the Enumclaw – Greenwater transmission system needs is the wires solution Alternative 3, described below. See Figure 0-3 for an illustration of the proposed solution.

The wires solution is subdivided into two phases of work:

#### **Phase 1 Scope:**

- Provide a new 115kV-55kV/34.5kV substation at or near the existing Weyerhaeuser White River (WWR) substation site with a Circuit Switcher and 34.5kV circuit breaker
- Convert existing 55kV Transmission line to 115kV from the intersection of Stevenson St. and Railroad St. in Enumclaw to the new substation site at or near WWR
- Remove the existing Stevenson Switch (STE) and provide new pole-mounted transmission switches on the north, south, and east sides of the tap. Install a new Transmission automation scheme, including fault locating.
- The system downstream of the new substation will remain at 55kV until Phase 2 is complete, where the system will be converted to 35kV.

#### **Phase 2 Scope:**

- Convert the existing CLA substation transformer from 55-12.5 KV to 35-12.5 kV
- Install 9.9 miles of UG conduit and conductor along Hwy 410 starting at the existing Transmission River crossing at Crystal River Ranch
- Convert existing services along Hwy 410 from 12.47kV to 34.5kV as necessary
- Utilize the existing 34.5kV-12.47kV transformer to serve the Greenwater substation feeders and remove existing 55kV-12.47kV transformer.
  - Note that the 12.47kV distribution fed from circuit GWR-13 will remain
- Install a new 34.5kV Recloser south of the existing river crossing on Crystal Drive to sectionalize the feeder that serves Crystal Mountain.

Classification: Sensitive

*This document contains Critical Energy Infrastructure Information (CEII),  
the use or disclosure of which is protected.*



**Figure 0-3: Proposed Solution**

The benefits of the proposed solution include:

- Allows for improved reliability along the Greenwater Tap
  - UG conversion will result in fewer tree/vegetation related outages
  - Locating the line along Hwy 410 will improve access and shorten the duration of outages
- Eliminates the 55 kV operating voltage of the Greenwater Tap
  - 35kV distribution voltage allows more flexibility to provide reliability improvements
- Removes risk of system due to easement and CMZ issues
- Improves operational flexibility by providing an additional 115kV source for the Greenwater Tap
- Improves wildfire mitigation along Highway 410 due to underground conversion and removing infrastructure from FR 3700 within the heavily forested area

Classification: Sensitive

*This document contains Critical Energy Infrastructure Information (CEII),  
the use or disclosure of which is protected.*

---

# 1 Introduction, Methodology and Key Assumptions

---

After completion of the Enumclaw - Greenwater Needs Assessment, Puget Sound Energy (PSE) conducted analyses of traditional alternatives (wires) and non-wires alternatives (NWAs) to determine a cost-effective solution that addresses the identified system needs for the Greenwater Tap over the 10 year planning horizon (2020-2029).

## 1.1 Methodology

---

This solutions study used the following process:

1. Step one: Brainstorm potential solution types to solve the identified system needs, including conventional wires type, non-wires type like batteries, energy efficiency and distributed energy resources (DERs), and hybrid type that involved combination of wires and non-wires components.
2. Step two: Identify possible alternatives for each solution type. PSE studied conventional wires alternatives and non-wires alternatives.
3. Step three: Assess the most promising alternatives using the solution criteria for system performance in terms of capacity, reliability, asset life and constructability; and determine viable alternatives. An alternative was considered viable if it met all of the solution criteria.
4. Step four: Identify and compare the most viable alternatives.
5. Step five: Compare the top alternatives in terms of cost, benefits, drawbacks and risks to identify the proposed solution.

Figure 1-1 shows the process flow for the solutions study methodology.

PSE started the analysis with many conventional wires alternatives and then shortlisted the alternatives to viable alternatives that met the solution criteria. The viable wires alternatives were compared in terms of cost, benefits, drawbacks and risks to generate the preferred wires alternative. The preferred wires alternative was used as a reference for development of non-wires and hybrid alternatives. As a final step, the top alternatives for the wires, non-wires and hybrid categories were compared to determine the preferred solution that best met Greenwater Tap solutions criteria.

Classification: Sensitive

*This document contains Critical Energy Infrastructure Information (CEII),  
the use or disclosure of which is protected.*

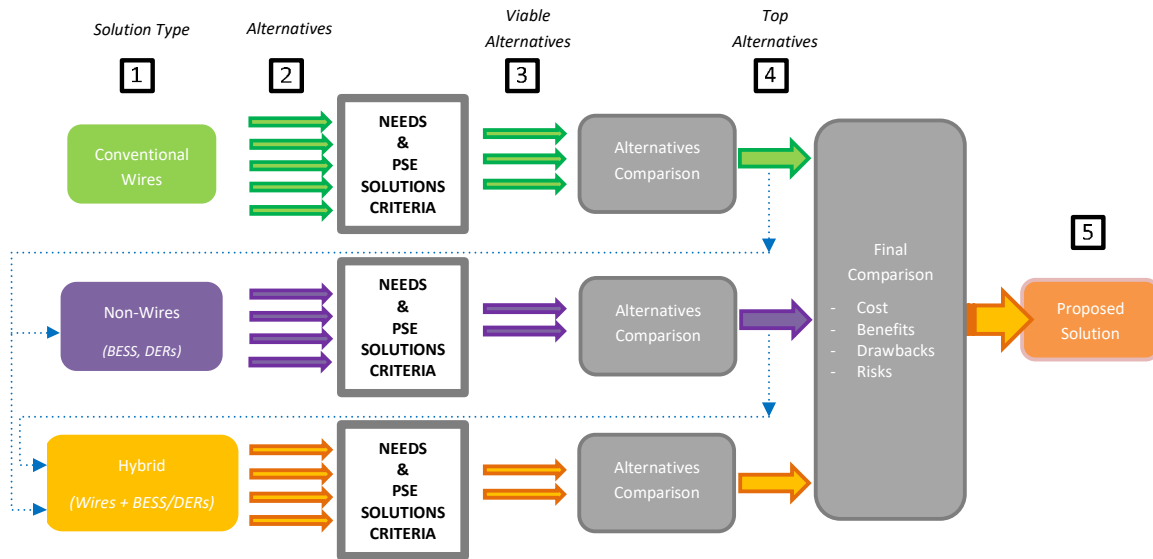

Figure 1-1: PSE Solutions Study Methodology

## 1.2 Solution Criteria

PSE evaluates alternatives with electrical and non-electrical criteria. These criteria are based on federal requirements, PSE planning guidelines, and industry standards, as well as project implementation considerations.

A proposed alternative is considered viable if it addresses all identified solution criteria. A viable alternative is not required to but may also address identified *concerns*, if deemed prudent or advantageous to include in the project scope.

### Technical Criteria:

- Must meet all performance criteria:
  - Address needs identified within the ten year study period
  - Does not re-trigger any of the needs identified in the Needs Assessment for 10 years or more after the solution is in service

### Transmission:

- Applicable transmission planning standards including mandatory North American Electric Reliability Corporation (NERC) and Western Electricity Coordinating Council (WECC) standards (e.g., NERC TPL-001-4 and WECC TPL-001-WECC-CRT-3.2)
- Applicable PSE Transmission Planning Guidelines as follows:
  - Transmission planning guideline for upgrading existing infrastructure in radial transmission line configuration when load served exceeds 15 to 20 MW
- ≤ 100% of Planning's emergency limit for lines and transformers for NERC TPL-001-4 P1-P7 contingencies for the 10-year planning horizon

Classification: Sensitive

*This document contains Critical Energy Infrastructure Information (CEII),  
the use or disclosure of which is protected.*

- Take into account planned transmission system improvement projects that are expected to be in-service within study period
- No load shedding
- No interim operating plans

*Distribution:*

- Applicable PSE Distribution Planning Guidelines as follows:
  - Individual substation utilization in study area  $\leq$  100% of capacity
  - Total utilization of all substations in study group  $\leq$  85% of capacity
  - $\leq$  100% of overhead individual feeder limits for N-0 and applicable N-1 scenarios
  - $\leq$  100% of underground individual feeder limits for N-0 and applicable N-1 scenarios

*Reliability:*

- For areas with high non-MED<sup>6</sup> SAIDI<sup>7</sup> or non-MED SAIFI<sup>8</sup>, solution must reduce non-MED SAIDI and non-MED SAIFI.

*Design Requirements:*

- Must meet applicable Institute of Electrical and Electronics Engineers (IEEE) and NERC standards
  - Must meet Washington Administrative Code (WAC) and National Electrical Safety Code (NESC)
  - Must use PSE standard equipment and be consistent with the PSE Major Equipment Committee's spare equipment strategy
  - Must meet PSE best practices for operations and maintenance
2. Must address all needs identified in the Needs Assessment Report.
  3. Must not cause any adverse impacts to the reliability or operating characteristics of PSE's or surrounding systems.

Non-technical Criteria:

1. Feasible permitting
2. Reasonable project cost
3. Uses proven technology that may be adopted at a system level<sup>9</sup>

---

<sup>6</sup> MED (Major Event Day): See definition in Glossary

<sup>7</sup> SAIDI (System Average Interruption Duration Index): See definition in Glossary

<sup>8</sup> SAIFI (System Average Interruption Frequency Index): See definition in Glossary

<sup>9</sup> PSE defines "proven technology" as technology that has been operationalized in the utility industry

Classification: Sensitive

*This document contains Critical Energy Infrastructure Information (CEII),  
the use or disclosure of which is protected.*

#### 4. Constructible within reasonable timeframe

### 1.3 Study Assumptions

---

For this solutions study, the following key assumptions were made:

- The study used PSE's Crystal Mountain load forecast<sup>10</sup> for specifically projecting Greenwater Tap load for the solution window.
- For alternatives involving battery energy storage system (BESS):
  - An 8 hour backup for transmission outages was considered sufficient duration for PSE to repair and restore most transmission line outages<sup>11</sup>.
- The estimated cost of acquiring land rights was included in each alternative. Although estimates are included, actuals may vary widely.

---

<sup>10</sup> See Enumclaw - Greenwater Needs Assessment report for details on load forecast for the Greenwater Tap

<sup>11</sup> Excludes storm related outages which can take longer duration for restoration. 8-hour battery backup covered 87% of Non-storm transmission outages affecting the Greenwater Tap in the 5 year period from 2015-2019

Classification: Sensitive

*This document contains Critical Energy Infrastructure Information (CEII),  
the use or disclosure of which is protected.*



## 2 Needs Summary

PSE performed a needs assessment for the Enumclaw - Greenwater transmission and distribution system. The needs assessment determined that over the 10-year planning horizon, the needs and concerns were primarily regarding reliability and aging infrastructure. For the complete needs assessment, refer to the Enumclaw - Greenwater Needs Assessment report.

### 2.1 Needs and Concerns

The Enumclaw - Greenwater Needs Assessment examined the transmission and distribution system serving the Greenwater area for the 10-year planning horizon (2020-2029). Planners reviewed the transmission and distribution system’s historical reliability performance to identify areas needing improvement, as well as future capacity needs.

As a result of this study, PSE identified the following needs and concerns<sup>12</sup> summarized below in Table 2-1:

**Table 2-1: Greenwater Area Needs and Concerns Summary**

Needs/Concerns #		Problem	Risk	Why is this a need?	Solution Possible in Existing System configuration?	
1	Transmission Reliability	Outage Exposure	Greenwater Tap Reliability is significantly worse than average for PSE transmission lines	Continual outages in the area affect customer reliability and company reliability targets	Reliability of this transmission line is significantly worse than system average. This line experiences both more frequent and longer duration outages than typical PSE transmission lines	Maybe
2	Easement Rights	Easement Rights	PSE has insufficient easement rights on Forest Road 3700, where the Greenwater Tap runs for 9 miles	PSE is not able to rebuild access roads to create temporary or permanent access in the event of a washout, making repairs on the line extremely difficult	Maintaining access to infrastructure is a critical need for maintenance, vegetation management, and repairs	No
3	Channel Migration Zone	CMZ Issues	Several poles of the Greenwater Tap are within the White River Channel Migration Zone and have been identified to be at risk	The Muckleshoot Federal Corporation has identified their intention to let the White River migrate naturally, which puts access roads and utility infrastructure at risk. Additionally, installing new infrastructure in this corridor will require extensive permitting and environmental support	Maintaining access to infrastructure is a critical need for maintenance, vegetation management, and repairs	No
4	Obsolete Infrastructure	55kV Infrastructure	PSE is not planning to utilize 55kV Transmission in the long term and this is becoming an obsolete voltage level	PSE no longer actively supports 55kV Transmission and the spare transformers are at the end of their useful economic life. A loss of one of the 55kV transformer would result in significant issues on the transmission system	As PSE stops supporting 55kV, there will be a lack of spare equipment and the ability to repair 55kV infrastructure	No
5	Power Quality	Power Quality	There have been several instances of 55kV Transmission sagging into 12.5kV Distribution, causing voltage surge events	Without fixing the potential for transmission to sag into distribution, PSE is at risk of future claims from affected customers	Voltage surge events put PSE at risk for customer claims and damaged equipment	No
6	Operational Flexibility	Radial Transmission Feed	The Greenwater Tap is a radial Transmission line with a single source at Krain Corner and Normal Open at Stevenson switch	The 115kV Transmission Bus at Krain Corner is a Main Bus Only, causing an outage for the entire Greenwater Tap during maintenance. Additionally, any outage on the Greenwater Tap results in an outage for all the customers due to the lack of switching options	Improving operational flexibility for the transmission system will improve system reliability and the ability for operators to manage the system	No
7	Storm Resiliency	Outage Duration	The Greenwater Tap is a remote line at the edge of the system and experiences longer than average outages, especially during storm conditions	During storm conditions, the Greenwater Tap can be out for multiple days at a time due to safety, access, and other conditions. These outages are costly to PSE and customers	Improving PSE's ability to restore power during storm conditions will benefit customer reliability and PSE safety	No

Legend
Need
Concern

Potential alternatives must address all of the system needs identified in this study, while also considering the identified concerns.

<sup>12</sup> A *need* is defined as a constraint or limitation on the delivery system in providing safe and reliable electric supply to customers. A need is a “must-have” that is required to be addressed for the system in a timely manner (by a certain Need Date) as determined in the Needs Assessment study for a planning horizon and defined in the Solution Criteria. A *concern* is a non-critical issue that impacts system operations but may be overcome with alternate work plans. Concerns if unattended for long period manifest into needs, and may then require attention.

Classification: Sensitive  
 This document contains Critical Energy Infrastructure Information (CEII),  
 the use or disclosure of which is protected.

---

## 3 Wires Alternatives

---

PSE studied a variety of wires alternatives, which are listed below for reference. Alternatives were developed to meet all identified needs of the Greenwater Tap with additional consideration for solutions that meet concerns as well. This section of the report discusses and compares the top alternatives for the wires solutions.

Wires alternatives consisted of the following options that were considered:

- **No Action Alternative**
- **Alternative 1:** 115kV Conversion from Krain Corner to Greenwater
- **Alternative 2:** 115kV Conversion from Krain Corner to Clay Creek and 35kV Conversion to Greenwater
- **Alternative 3:** 115kV Conversion from Krain Corner to Weyerhaeuser White River and 35kV Conversion to Greenwater
- **Alternative 4:** 35kV Conversion from Krain Corner to Greenwater

Some alternatives were eliminated and deemed non-viable as they did not meet the PSE solution criteria as defined in Section 1.2. Alternatives that met all of the solution criteria were deemed viable and considered for further evaluation. Viable alternatives for each category were compared to determine the top alternative for the category.

The following sections provide detailed descriptions of each wires solution, including scope, cost, and benefits.

### 3.1 No Action Alternative

---

PSE considered a scenario where no action is taken to improve the transmission reliability needs.

Under this alternative, PSE would continue to have aging infrastructure concerns and would continue to operate the 55 kV system, but would eventually be required to purchase additional 55 kV equipment when existing equipment fails. This will result in a decrease in service reliability, as outages are likely to be needed for unknown durations depending upon when / how the equipment fails and the lead time to acquire a replacement.

### 3.2 Alternative 1: 115kV to Greenwater

---

Alternative 1 requires converting the entire 55kV transmission line to 115kV from Krain Corner substation to Greenwater substation. This alternative would have to coordinate with the existing Electron Heights to Enumclaw 115kV conversion project (EHT-ENU Conversion) and would tap off the newly converted 115kV transmission near the intersection of Railroad St. and Stevenson Ave. From this tap, the existing 55kV transmission would be converted and re-built to 115kV standard.

This alternative would require new distribution transformers to feed customers at both Clay Creek and Greenwater substations.

Alternative 1 provides the most flexibility to serve future load, but provides capacity that is well beyond the 10-year need of the area. Standard transmission construction would provide improved reliability for

Classification: Sensitive

*This document contains Critical Energy Infrastructure Information (CEII),  
the use or disclosure of which is protected.*

the line, but would not prevent all outages or significantly reduce the duration of outages during storm conditions.

Additionally, it is very costly to rebuild the existing 55kV transmission to 115kV and there is considerable risk in obtaining the necessary access and easements for the entire path.

**Table 3-1. Alternative 1 Needs and Concerns Analysis**

Alternative 1: 115kV Conversion to Greenwater Substation					
	Needs Criteria		Problem	Description of Proposed Solution	Alternative 1 Solves Needs Criteria?
1	Transmission Reliability	Outage Exposure	Greenwater Tap Reliability is significantly worse than average for PSE transmission lines	Rebuilding the line to 115kV standard along Hwy 410 would improve reliability of the line	Partial
2	Easement Rights	Easement Rights	PSE has insufficient easement rights on Forest Road 3700, where the Greenwater Tap runs for 9 miles	Converting the line to 115kV would require rebuilding along Hwy 410 to get off of Forest Road 3700	Yes
3	Channel Migration Zone	CMZ Issues	Several poles of the Greenwater Tap are within the White River Channel Migration Zone and have been identified to be at risk	Relocating the line and use of Steel structures as necessary will mitigate the risk of CMZ washout	Yes
4	Obsolete Infrastructure	55kV Infrastructure	PSE is not planning to utilize 55kV Transmission in the long term and this is becoming an obsolete voltage level	This alternative eliminates all 55kV on the Greenwater Tap	Yes
5	Power Quality	Power Quality	There have been several instances of 55kV Transmission sagging into 12.5kV Distribution, causing voltage surge events	Using standard 115kV construction with 12.5kV distribution underbuild will eliminate the risk of voltage surge events	Yes
6	Operational Flexibility	Radial Transmission Feed	The Greenwater Tap is a radial Transmission line with a single source at Krain Corner	This alternative would tap off the existing 115kV line and provide improved operational flexibility	Yes
7	Storm Resiliency	Outage Duration	The Greenwater Tap is a remote line at the edge of the system and experiences longer than average outages, especially during storm conditions	Access would be improved, but much of the system would be a risk during storm conditions	Partial

<b>Legend</b>
Need
Concern

### 3.3 Alternative 2: 115kV to Clay Creek, 35kV to Greenwater

Alternative 2 requires converting the existing 55kV transmission line to 115kV from Krain Corner substation to Clay Creek substation and converting the remaining 55kV transmission from Clay Creek to Greenwater to 35kV distribution. This alternative would have to coordinate with the existing Electron Heights to Enumclaw 115kV conversion project (EHT-ENU Conversion) and would tap off the newly converted 115kV transmission near the intersection of Railroad St. and Stevenson Ave. From this tap, the existing 55kV transmission would be converted and re-built to 115kV standard.

This alternative would require new distribution transformers to feed customers at Clay Creek and would utilize the existing transformer at Greenwater substation.

Alternative 2 provides improved flexibility to serve future load. Standard transmission construction would improve reliability for the line between Krain Corner and Clay Creek, but would not prevent all outages or significantly reduce the duration of outages during storm conditions. The majority of the 35kV distribution between Clay Creek and Greenwater would be converted underground along Highway 410, which would improve reliability and access during storm conditions.

The existing 55kV transmission is framed for 115kV between Krain Corner and Weyerhaeuser White River substations, but it is very costly to rebuild the remaining 55kV transmission to 115kV between Weyerhaeuser White River and Clay Creek.

Classification: Sensitive

*This document contains Critical Energy Infrastructure Information (CEII), the use or disclosure of which is protected.*

**Table 3-2. Alternative 2 Needs and Concerns Analysis**

**Alternative 2: 115kV Conversion to Clay Creek, 35kV to Greenwater**

	Needs Criteria		Problem	Description of Proposed Solution	Alternative 1 Solves Needs Criteria?
1	Transmission Reliability	Outage Exposure	Greenwater Tap Reliability is significantly worse than average for PSE transmission lines	Rebuilding the line to 115kV standard along Hwy 410 would improve reliability of the line. 35kV to Greenwater allows for UG Conversion	Yes
2	Easement Rights	Easement Rights	PSE has insufficient easement rights on Forest Road 3700, where the Greenwater Tap runs for 9 miles	Converting the line to 35kV would require rebuilding along Hwy 410 to get off of Forest Road 3700	Yes
3	Channel Migration Zone	CMZ Issues	Several poles of the Greenwater Tap are within the White River Channel Migration Zone and have been identified to be at risk	Relocating the line and use of Steel structures as necessary will mitigate the risk of CMZ washout	Yes
4	Obsolete Infrastructure	55kV Infrastructure	PSE is not planning to utilize 55kV Transmission in the long term and this is becoming an obsolete voltage level	This alternative eliminates all 55kV on the Greenwater Tap	Yes
5	Power Quality	Power Quality	There have been several instances of 55kV Transmission sagging into 12.5kV Distribution, causing voltage surge events	Using standard 115kV construction with 12.5kV distribution underbuild and 35kV distribution will eliminate the risk of voltage surge events	Yes
6	Operational Flexibility	Radial Transmission Feed	The Greenwater Tap is a radial Transmission line with a single source at Krain Corner	This alternative would tap off the existing 115kV line and provide improved operational flexibility	Yes
7	Storm Resiliency	Outage Duration	The Greenwater Tap is a remote line at the edge of the system and experiences longer than average outages, especially during storm conditions	Access would be improved and UG 35kV Conversion will improve Storm Resiliency	Yes

Legend
Need
Concern

### 3.4 Alternative 3: 115kV to Weyerhaeuser White River, 35kV to Greenwater

Alternative 3 requires converting the existing 55kV transmission line to 115kV from Krain Corner substation to Weyerhaeuser White River substation and converting the remaining 55kV transmission from Weyerhaeuser White River to Greenwater to 35kV distribution. This alternative would have to coordinate with the existing Electron Heights to Enumclaw 115kV conversion project (EHT-ENU Conversion) and would tap off the newly converted 115kV transmission near the intersection of Railroad St. and Stevenson Ave. From this tap, the existing 55kV transmission would be converted and re-built to 115kV standard.

This alternative would require a rebuilt substation at or near the existing substation at Weyerhaeuser White River, including a Circuit Switcher, Distribution Transformer, and 35kV Circuit breaker. The current owners of the WWR substation have expressed interest in selling the property to PSE, however the permitting and construction of the substation is a potential risk. This alternative would also require new distribution transformers to feed customers at Clay Creek and would utilize the existing transformer at Greenwater substation.

Alternative 3 provides improved flexibility to serve future load. Standard transmission construction would provide improved reliability for the line between Krain Corner and WWR, but would not prevent all outages or significantly reduce the duration of outages during storm conditions. The majority of the 35kV distribution between Clay Creek and Greenwater would be converted underground along Highway 410, which would improve reliability and access during storm conditions.

Classification: Sensitive

*This document contains Critical Energy Infrastructure Information (CEII),  
the use or disclosure of which is protected.*

**Table 3-3. Alternative 3 Needs and Concerns Analysis**

Alternative 3: 115kV Conversion to WWR, 35kV to Greenwater					
	Needs Criteria		Problem	Description of Proposed Solution	Alternative 1 Solves Needs Criteria?
1	Transmission Reliability	Outage Exposure	Greenwater Tap Reliability is significantly worse than average for PSE transmission lines	Converting the line to 35kV to Greenwater allows for UG Conversion and improves reliability	Yes
2	Easement Rights	Easement Rights	PSE has insufficient easement rights on Forest Road 3700, where the Greenwater Tap runs for 9 miles	Converting the line to 35kV would require rebuilding along Hwy 410 to get off of Forest Road 3700	Yes
3	Channel Migration Zone	CMZ Issues	Several poles of the Greenwater Tap are within the White River Channel Migration Zone and have been identified to be at risk	Relocating the line will mitigate the risk of CMZ washout	Yes
4	Obsolete Infrastructure	55kV Infrastructure	PSE is not planning to utilize 55kV Transmission in the long term and this is becoming an obsolete voltage level	This alternative eliminates all 55kV on the Greenwater Tap	Yes
5	Power Quality	Power Quality	There have been several instances of 55kV Transmission sagging into 12.5kV Distribution, causing voltage surge events	Using standard 35kV distribution will eliminate the risk of voltage surge events	Yes
6	Operational Flexibility	Radial Transmission Feed	The Greenwater Tap is a radial Transmission line with a single source at Krain Corner	This alternative would tap off the existing 115kV line and provide improved operational flexibility	Yes
7	Storm Resiliency	Outage Duration	The Greenwater Tap is a remote line at the edge of the system and experiences longer than average outages, especially during storm conditions	Access would be improved and UG 35kV Conversion will improve Storm Resiliency	Yes

Legend
Need
Concern

### 3.5 Alternative 4: 35kV from Krain Corner to Greenwater

Alternative 4 requires converting the existing 55kV transmission line to 35kV distribution from Krain Corner substation to Greenwater substation. This alternative requires a new distribution transformer fed from the 115kV bus at Krain Corner. The addition of a transformer to the Krain Corner 115 KV main bus would require reconfiguration of the bus to a Ring bus, per the PSE Transmission Planning guidelines. This alternative would also require construction of a new 35kV distribution feeder from Krain Corner, through the city of Enumclaw, to the existing line on Stevenson Ave. This new distribution line could be a combination of overhead and underground construction, depending on the route. From Stevenson Ave, the existing transmission line will be utilized and operated at 35kV.

This alternative would require new distribution transformers to feed customers at Clay Creek and would utilize the existing transformer at Greenwater substation.

Alternative 4 constructs a radial distribution line with Krain Corner as the only source and does not address operational flexibility concerns. Additionally, future growth along the Greenwater Tap is limited to the capacity of the 35kV distribution system. Distribution improvements, including Tree Wire and underground conversion along Highway 410 would improve reliability and access during storm conditions.

Classification: Sensitive

*This document contains Critical Energy Infrastructure Information (CEII),  
the use or disclosure of which is protected.*

**Table 3-4. Alternative 4 Needs and Concerns Analysis**

Alternative 4: 35kV conversion from Krain Corner to Greenwater

	Needs Criteria		Problem	Description of Proposed Solution	Alternative 1 Solves Needs Criteria?
1	Transmission Reliability	Outage Exposure	Greenwater Tap Reliability is significantly worse than average for PSE transmission lines	Converting the line to 35kV to Greenwater allows for UG Conversion and improves reliability	Yes
2	Easement Rights	Easement Rights	PSE has insufficient easement rights on Forest Road 3700, where the Greenwater Tap runs for 9 miles	Converting the line to 35kV would require rebuilding along Hwy 410 to get off of Forest Road 3700	Yes
3	Channel Migration Zone	CMZ Issues	Several poles of the Greenwater Tap are within the White River Channel Migration Zone and have been identified to be at risk	Relocating the line will mitigate the risk of CMZ washout	Yes
4	Obsolete Infrastructure	55kV Infrastructure	PSE is not planning to utilize 55kV Transmission in the long term and this is becoming an obsolete voltage level	This alternative eliminates all 55kV on the Greenwater Tap	Yes
5	Power Quality	Power Quality	There have been several instances of 55kV Transmission sagging into 12.5kV Distribution, causing voltage surge events	Using standard 35kV distribution will eliminate the risk of voltage surge events	Yes
6	Operational Flexibility	Radial Transmission Feed	The Greenwater Tap is a radial Transmission line with a single source at Krain Corner	Line remains a single source from Krain Corner	No
7	Storm Resiliency	Outage Duration	The Greenwater Tap is a remote line at the edge of the system and experiences longer than average outages, especially during storm conditions	Access would be improved and UG 35kV Conversion will improve Storm Resiliency	Yes

Legend
Need
Concern

Classification: Sensitive

*This document contains Critical Energy Infrastructure Information (CEII), the use or disclosure of which is protected.*

## 4 Non-Wires Alternatives

PSE contracted Guidehouse Consulting (Guidehouse) to perform non-wires analysis to consider the technical and economic feasibility of an alternative that consists of energy storage and distributed energy resources (DERs).

### 4.1 Guidehouse Consulting Analysis

Guidehouse considered the technical and economic feasibility of an alternative that consists entirely of non-wires alternatives (NWAs), and alternatives consisting of both energy storage and other distributed energy resources (DERs).



**Figure 4-1. Guidehouse NWA Process**

Guidehouse first completed a foundational assessment based on PSE’s needs assessment to identify and prioritize the needs and concerns and identify any potential alternatives that will meet PSE’s solution criteria. With the results of the Foundational Assessment, a Basic Analysis was completed to determine the technical, logistical, economic, and timing analysis of the alternative based on industry experience and general rules of thumb. The results from Basic Analysis were used to determine whether the Detailed Analysis and/or Advanced Analysis steps were necessary<sup>13</sup>.

### 4.2 Non-Wires Alternatives

Upon completion of the Basic Analysis, Guidehouse determined that a fully islanded microgrid is the only viable NWA option that would meet the Greenwater Tap reliability needs. Guidehouse performed a technical and economic feasibility study for two microgrid options: Large Battery Case and Large Solar Case. Table 4-1 below provides a comparison of the two non-wire alternatives.

#### 4.2.1.1 Large Battery Case

The large battery case used a test case where a reasonably sized solar array of 10 MW would be paired with 8.1 MW of energy storage that would provide a microgrid for the Greenwater Tap. Due to the winter peaking nature of the area loads, when solar output is generally low, the duration of the energy storage would need to be extremely long at 1,898 hours. The total overall cost for this alternative is

<sup>13</sup> Greenwater NWA Report, Guidehouse Consulting, Page 3.

Classification: Sensitive

*This document contains Critical Energy Infrastructure Information (CEII),  
the use or disclosure of which is protected.*

~\$4.7 billion. This alternative is considered both economically and technically infeasible because of the magnitude of storage required.

#### 4.2.1.2 Large Solar Case

The large solar case proposed an optimally sized solar array of 85 MW paired with energy storage of 64.2 MW and a duration of 13.9 hours. While the solar array and battery storage have a much larger capacity, the significantly shorter duration of the storage reduces the overall cost. The total cost of the large solar case is ~\$380 million. Even with the reduced cost, this alternative is both economically and technically infeasible because of the physical space limitations to develop a solar array of this size.

Table 4-1. NWA Alternative Comparison

Component	Large Solar Case	Large Battery Case
PV Cost Estimate (\$/MW DC)	\$1.0	\$1.0
Installed PV Capacity (MW DC)	85.0	10.0
ESS per MW Cost Estimate (\$/MW)	\$0.31194	\$0.31194
ESS per MWh Cost Estimate (\$/MWh)	\$0.30844	\$0.30844
ESS Efficiency (%)	90%	90%
ESS Need (MW)	64.2	8.1
ESS Duration (hours)	13.9	1898.1
ESS Size (MWh)	892.6	15,313.8
Demand Side Management Cost Estimate (\$M)	\$0.0	\$0.0
PV Cost Estimate (\$M)	\$85.0	\$10.0
ESS Cost Estimate (\$M)	\$295.3	\$4,725.9
<b>NWA Portfolio Cost Estimate (\$M)</b>	<b>\$380.3</b>	<b>\$4,735.9</b>

Source: Guidehouse analysis

### 4.3 Non-Wire Analysis Conclusion

After completing the Foundational Assessment and Basic Analysis, Guidehouse concluded there were no cost-effective Non-wires alternatives that met the needs and concerns of the Greenwater Tap.

The forecasted growth of electrical loads due to large customer additions and the winter peaking profile of the Tap create cost and technical challenges that prohibit the possibility of installing a microgrid or any other non-wire alternative to meet the identified needs and concerns.

Classification: Sensitive

*This document contains Critical Energy Infrastructure Information (CEII),  
the use or disclosure of which is protected.*



## 5 Comparison of Alternatives

The top wires, non-wires, and hybrid alternatives were described above in Section 3 and Section 4. A comparison of the wires alternatives is shown below in Table 5-1, including the project costs for each alternative. This table describes how each alternative would meet the needs and concerns of the project.

**Table 5-1. Wires Alternative Comparison**

Alternatives		Reliability		Operations			Miscellaneous		Estimated Cost \$ (in Millions)
		Transmission Line Reliability	Storm Resiliency	Obsolete Infrastructure	Easement Rights	Operational Flexibility	Channel Migration Zone	Power Quality	
0	Do Nothing	X	X	Partial	X	X	X	X	\$6
1	115kV to GWR	Partial	Partial	✓	✓	✓	✓	✓	\$30
2	115kV to CLA, 35kV to GWR	✓	✓	✓	✓	✓	✓	✓	\$32
3	115kV to WWR, 35kV to GWR	✓	✓	✓	✓	✓	✓	✓	\$17
4	35kV from Krain to GWR	✓	✓	✓	✓	X	✓	✓	\$24

**Legend**

X - Does not meet Needs/Concerns
✓ - Meets Needs/Concerns
Partial
Need
Concern

### 5.1 Decision Factors – Qualitative Analysis

As shown in Table 5-1, all the Wires Alternatives meet the needs identified. Only Alternative 4 does not meet the identified concerns.

The cost comparison shows that Alternatives 1 and 2 are significantly more costly and are thus considered nonviable solutions. Although Alternative 4 does not meet all concerns, it must be qualitatively compared to Alternative 3 since both solutions meet all needs at marginally higher cost.

Alternatives 3 and 4 both include converting the existing 55kV transmission line to 35kV distribution beyond the existing WWR substation. The differences in these alternatives that need to be compared include the technical and operational differences of the system between Krain Corner and WWR.

- Alternative 3:** This alternative proposes to tap off the newly constructed 115kV transmission line between Buckley substation and Enumclaw substation near the intersection of Railroad Street and Stevenson Avenue. From this point the existing 55kV transmission line will be converted to 115kV to the WWR substation. This alternative includes purchasing the WWR substation from the existing customer and installing a new 115:55/35kV transformer, including a circuit switcher and circuit breaker.
- Alternative 4:** This alternative proposes installing a new 115kV:35kV transformer at Krain Corner, reconfiguring the KRA 115kV bus to a ring bus, and installing new 35kV distribution through the City of Enumclaw. The new route will connect to the existing transmission system somewhere along Roosevelt Avenue, where the existing system will be converted to 35kV distribution.

Classification: Sensitive

*This document contains Critical Energy Infrastructure Information (CEII),  
the use or disclosure of which is protected.*

The risks and benefits of each Alternative is summarized below in Table 5-2.

**Table 5-2. Qualitative Analysis - Benefits and Risks**

Alternative	Benefit	Risk
<b>Alternative 3</b>	<ul style="list-style-type: none"> <li>• Improved Operational Flexibility with multiple 115kV sources</li> <li>• No distribution voltage at Krain Corner</li> <li>• Transmission Automation scheme provides improved reliability for customers</li> <li>• 115kV voltage in area for future growth</li> <li>• Dual-secondary transformer provides spares for existing 55kV system</li> </ul>	<ul style="list-style-type: none"> <li>• Purchasing existing customer-owned WWR substation site</li> <li>• Constructability of expanded substation at existing WWR substation</li> <li>• Coordinate with existing EHT-ENU conversion project</li> </ul>
<b>Alternative 4</b>	<ul style="list-style-type: none"> <li>• Utilizes existing substation property</li> <li>• No 115kV conversion required</li> <li>• Distribution voltage provides flexible constructability (OH vs. UG)</li> </ul>	<ul style="list-style-type: none"> <li>• New distribution through City of Enumclaw</li> <li>• Single source radial feeder</li> <li>• Requires reconfiguring KRA 115kV bus to a Ring Bus</li> <li>• Future growth limited by 35kV system</li> </ul>

This analysis leads to Alternative 3 being identified as the preferred solution to meet the needs and concerns of the Greenwater Tap. The following Section describes the preferred solution in detail.

Classification: Sensitive

*This document contains Critical Energy Infrastructure Information (CEII),  
the use or disclosure of which is protected.*

## 6 Preferred Solution

The top alternatives were presented in Section 3 and Section 4 above. Based on the comparison analysis provided in Section 5, the preferred solution is described below.

Based on the alternatives analysis, the preferred solution to meet the needs and concerns of the Greenwater Tap is Alternative 3: 115kV Conversion from Krain Corner to Weyerhaeuser White River and 35kV Conversion to Greenwater. This solution will meet all needs and concerns at the lowest cost, while providing future flexibility for PSE's transmission and distribution systems.



Figure 6-1. Preferred Solution - Overall

The details of the preferred solution are included below and illustrated in Figure 6-2 and Figure 6-3.

Classification: Sensitive

*This document contains Critical Energy Infrastructure Information (CEII),  
the use or disclosure of which is protected.*



**Figure 6-2. Preferred Alternative - Phase 1 Scope**

**Phase 1 Scope:**

- Provide a new 115kV-55kV/34.5kV substation at or near the existing Weyerhaeuser White River (WWR) substation site with a Circuit Switcher and 34.5kV circuit breaker
- Convert existing 55kV Transmission line to 115kV from the intersection of Stevenson St. and Railroad St. in Enumclaw to the new substation site at or near WWR
- Remove the existing Stevenson Switch (STE) and provide new pole-mounted transmission switches on the north, south, and east sides of the tap. Install a new Transmission automation scheme, including fault locating.
- The system downstream of the new substation will remain at 55kV until Phase 2 is complete, where the system will be converted to 35kV.

Classification: Sensitive

*This document contains Critical Energy Infrastructure Information (CEII),  
the use or disclosure of which is protected.*



**Figure 6-3. Preferred Alternative - Phase 2 Scope**

**Phase 2 Scope:**

- Convert the existing CLA substation from 55kV to 35kV
- Install 9.9 miles of UG conduit and conductor along Hwy 410 from the existing Transmission River crossing at Crystal River Ranch
- Convert existing services along Hwy 410 from 12.47kV to 34.5kV as necessary
- Utilize the existing 34.5kV-12.47kV transformer to serve the Greenwater substation and remove existing 55kV-12.47kV transformer.
  - Note that the 12.47kV distribution fed from circuit GWR-13 will remain
- Install a new 34.5kV Recloser south of the existing river crossing on Crystal Drive to sectionalize the feeder

**Wires Alternative Benefit Overview:**

- Reasonable cost and project timeframe
- Significantly improve reliability of the line
- Removes easement and CMZ issues
- Provides improved operational flexibility
- Eliminated obsolete infrastructure
- Provides spare equipment for aging 115kV-55kV transformers
- Improves wildfire mitigation impact along Highway 410

Classification: Sensitive

*This document contains Critical Energy Infrastructure Information (CEII),  
the use or disclosure of which is protected.*

## Appendix A Glossary

<b>Term</b>	<b>Definition</b>
Block load	A large expected increase in electric energy demand from an existing or new customer.
Circuit	A circuit is the electric equipment associated with serving all customers under normal configuration from a specific distribution circuit breaker at a substation.
CMI- Customer Minute Interruptions	CMI is the total combined minutes interrupted due to an outage. CMI is commonly used as a reliability indicator by electric power utilities.
Concern	A “concern” is a non-critical issue that impacts system operations but is <u>not</u> required to be addressed by a solution; a solution that addresses an identified concern provides additional benefit.
Conservation	Measures to improve efficiency of customer’s electric loads reducing energy use and reducing peak demand.
Consumption	Consumption is the amount of electricity that customers use over the course of a year and it’s measured in kilowatt hours.
Contingency	Contingencies are a set of transmission system failure modes, when elements are taken out of service (e.g., loss of equipment).
Corrective Action Plan	A Corrective Action Plan (CAP) is a solution to address transmission system deficiencies and meet performance requirements. A CAP may include system upgrades such as planned projects, topology modifications or operational plans to radially operate the system, run generation or even implement load shedding.
Curtable	A load that may be interrupted to reduce load on system during peak periods. Curtable customers are on a different rate schedule than non-curtable (firm) customers.
Demand	The amount of power being required by customers at any given moment, and it’s measured in kilowatts.
DR- Demand response	Flexible, price-responsive loads, which may be curtailed or interrupted during system emergencies or when wholesale market prices exceed the utility’s supply cost. Demand response is also the voluntary reduction of electricity demand during periods of peak electricity demand or high electricity prices. Demand response provides incentives to customers to temporarily lower their demand at a specific time in exchange for reduced energy costs.
Distributed generation	Small-scale electricity generators, like rooftop solar panels, located close to the source of the customer’s load.

Classification: Sensitive

*This document contains Critical Energy Infrastructure Information (CEII),  
the use or disclosure of which is protected.*

<b>Term</b>	<b>Definition</b>
Distribution line	A distribution line is a medium-voltage (12.5 kV-35 kV) line that carries electricity from a substation to customers. Roughly half of PSE's distribution lines are underground. Distribution voltage is stepped down to service voltage through smaller transformers located along distribution lines. Distribution lines differ from feeder as it includes the large feeder wire and smaller wire laterals.
Distribution System	A distribution system is the medium-voltage (12.5 kV-35 kV) infrastructure that carries electricity from a substation to customers and includes the substation transformer. System is the collective of all of this infrastructure in an entire study area.
EPRI- The Electric Power Research Institute	The Electric Power Research Institute conducts research, development, and demonstration projects for the benefit of the public in the United States and internationally. As an independent, nonprofit organization for public interest energy and environmental research, they focus on electricity generation, delivery, and use.
Feeder	A feeder is the largest conductor section of a circuit and generally
Institute of Electrical and Electronics Engineers (IEEE)	A professional association, promoting the development and application of electro-technology and allied sciences for the benefit of humanity, the advancement of the profession, and the well-being of our members.
Integrated Resource Plan (IRP)	The Integrated Resource Plan (IRP) is a forecast of conservation resources and supply-side resource additions that appear to be cost effective to meet the growing needs of our customers over the next 20 years. Every two years, utilities are required to update integrated resource plans to reflect changing needs and available information.
Interim Operating Plan (IOP)	A temporary plan to address a transmission system deficiency and meet performance requirements, until a solution takes effect. An IOP may consist of a series of operational steps to radially operate the system, run generation or implement load shedding.
Kilovolt (kV)	A kilovolt (kV) is equal to 1,000 volts of electric energy. PSE uses kilovolts as a standard measurement when discussing things like distribution lines and the energy that reaches our customers.
Load	The total of customer demand plus planning margins and operating reserve obligations.
Load forecast	A load forecast is a projection of how much power PSE's customers will use in future years. The forecast allows PSE to plan upgrades to its electric system to ensure that current and future customers continue to have reliable power. Federal regulations require that utilities plan a reliable system based on forecasted loads. When developing a load forecast, PSE takes multiple factors into account like current loads, economic and population projections, building permits, conservation goals, and weather events.

Classification: Sensitive

*This document contains Critical Energy Infrastructure Information (CEII),  
the use or disclosure of which is protected.*

<b>Term</b>	<b>Definition</b>
Load shedding	Load shedding is when a utility intentionally causes outages to customers because demand for electricity is exceeding the capacity of the electric grid. Load shedding is the option of last resort and is conducted to protect the integrity of the electric grid components in order to avoid a larger blackout. This is not a practice that PSE endorses as a long-term solution to meet mandatory performance requirements.
Major Event Day (MED)	Any day in which the daily system SAIDI exceeds the annual threshold value. Outages on those days are excluded from the SAIDI performance calculation.
Megawatt (MW)	A megawatt (MW) is equal to 1,000,000 watts of electric energy. PSE uses megawatts as a standard measurement when discussing things like system load and peak demand. MW differs from MVA in that it is generally always lower and translates as energy that performs work. The amount of MW vs MVA is determined by load characteristics. Motor loads generally have a lower power factor (PF) than heating loads for example and as a result. $MW=MVA*PF$
Mega Volt-Amp (MVA)	A MVA is equal to 1,000,000 (Volt*Amps). MVA is generally slightly higher than MW. Equipment ratings are in MVA as the equipment heat rise is determined by actual MVA.
N-0	This is a planning term describing that the electric grid is operating in a normal condition and no components have failed.
N-1	This is a planning term describing an outage condition when one system component has failed or has been taken out of service for construction or maintenance.
N-1-1	This is a planning term describing outage conditions where two failures occur one after another with a time delay between them.
N-2	This is a planning term describing outage conditions where two failures occur nearly simultaneously.
Native Load Growth	Load growth associated with existing customers or new customers less than 1 MW.
Need	A constraint or limitation on the delivery system in providing safe and reliable electric supply to customers. A need is a “must-have” that is required to be addressed for the system in a timely manner (by a certain Need Date, as determined in a needs assessment)
Non-wires alternatives	Alternatives that are not traditional poles, wires and substations. These alternatives can include demand reduction technologies, battery energy storage systems, and distributed generation.

Classification: Sensitive

*This document contains Critical Energy Infrastructure Information (CEII),  
the use or disclosure of which is protected.*



<b>Term</b>	<b>Definition</b>
NERC- North American Electric Reliability Corporation	NERC establishes the reliability standards for the North American grid.  NERC is a not-for-profit international regulatory authority whose mission is to ensure the reliability of the bulk power system in North America, as certified by FERC. NERC develops and enforces Reliability Standards and annually assesses seasonal and long-term reliability. PSE is required to meet the Reliability Standards and is subject to fines if noncompliant.
Peak demand	Customers' highest demand for electricity at any given time, and it's measured in megawatts.
Proven technology	Technology that has successfully operated with acceptable performance and reliability within a set of predefined criteria. It has a documented track record for a defined environment, meaning there are multiple examples of installations with a history of reliable operations. Such documentation shall provide confidence in the technology from practical operations, with respect to the ability of the technology to meet the specified requirements.
Reasonable project cost	Reasonable project cost means holistically comparing costs and benefits to project alternatives. This includes dollar costs, as well as duration of the solution, risk to the electric system associated with the type of solution (e.g., is the solution an untested technology), and impacts to the community.
Right of way	A corridor of land on which electric lines may be located. PSE may own the land in fee, own an easement, or have certain franchise, prescription, or license rights to construct and maintain lines.
Sensitivities	Sensitivities are circumstances or stressors under which the contingencies are tested (e.g., forecasted demand levels, interchange, various generation configurations).
Substation	A substation is a vital component of electricity distribution systems, containing utility circuit protection, voltage regulation and equipment that steps down higher-voltage electricity to a lower voltage before reaching your home or business.
Substation group	A grouping of 2-5 substation transformers that are situated close enough to each other that loads in the study area can be switched from one station to an adjacent station for maintenance, construction, or permanent load shifting.
Substation group capacity	The aggregate distribution transformer capacity of the substation group for winter and summer rating, calculated in MVA.
SAIDI- System Average Interruption Duration Index	SAIDI is the length of non-major-storm power outages per year, per customer. SAIDI is commonly used as a reliability indicator by electric power utilities. Outages longer than 5 minutes are included.

Classification: Sensitive

*This document contains Critical Energy Infrastructure Information (CEII),  
the use or disclosure of which is protected.*

Term	Definition
SAIFI- System Average Interruption Frequency Index	SAIFI is the frequency of non-major-storm power outages per year, per customer. SAIFI is commonly used as a reliability indicator by electric power utilities. Interruptions longer than 1 minute are included.
Transformer	A transformer is a device that steps electricity voltage down from a higher voltage, or steps it up to a higher voltage, depending on use. On the distribution system, transformers typically step the voltage down from a distribution voltage (12.5 kV) to 120 to 240 volts for customers' residential use. Transformers are the green boxes in some residences' front yard or the barrel-like canisters on utility poles.
Transmission line	Transmission lines are high-voltage lines that carry electricity from generation plants to substations or from substation to substation. Transformers at the substation "step down" the electricity's transmission voltage (55 to 230 kilovolts) to our primary distribution voltage (12.5 kV).

Classification: Sensitive

*This document contains Critical Energy Infrastructure Information (CEII),  
the use or disclosure of which is protected.*