

RECEIVED APRIL 27, 2020 WA. UT. & TRANS COMM. ORIGINAL UW-200382

CAD FILE NUMBER: P:\CLIENTS\WATER\TATOOSH\DEVELOPER EXTENSION\DRAWING\TATOOSH_VIMDE_FRANULOVICH\DRAWING\TATOOSH_VIMDE_FRANULOVICH\DWG\TATOOSH_VIM_DEV_EXTENSION_FRAN - ORIGINAL SHEET SIZE: ARCH FULL BLEED 0 (24.00 X 36.00) INCHES/AUTOCAD VERSION: CIVIL 3D 2015

TATOOSH WATER COMPANY VIEWMONT ESTATES - DEVELOPER EXTENSION ARLINGTON, WA

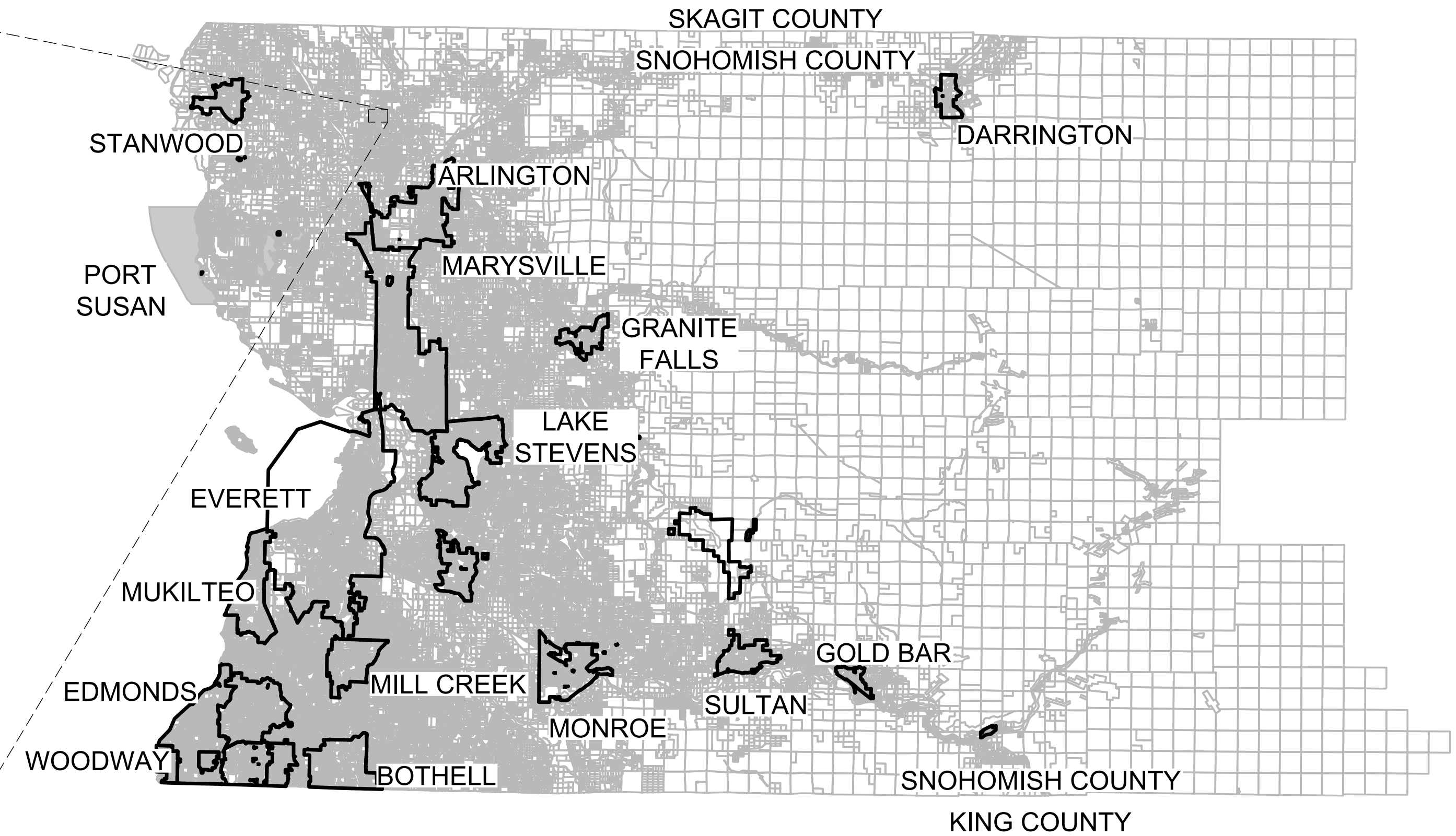
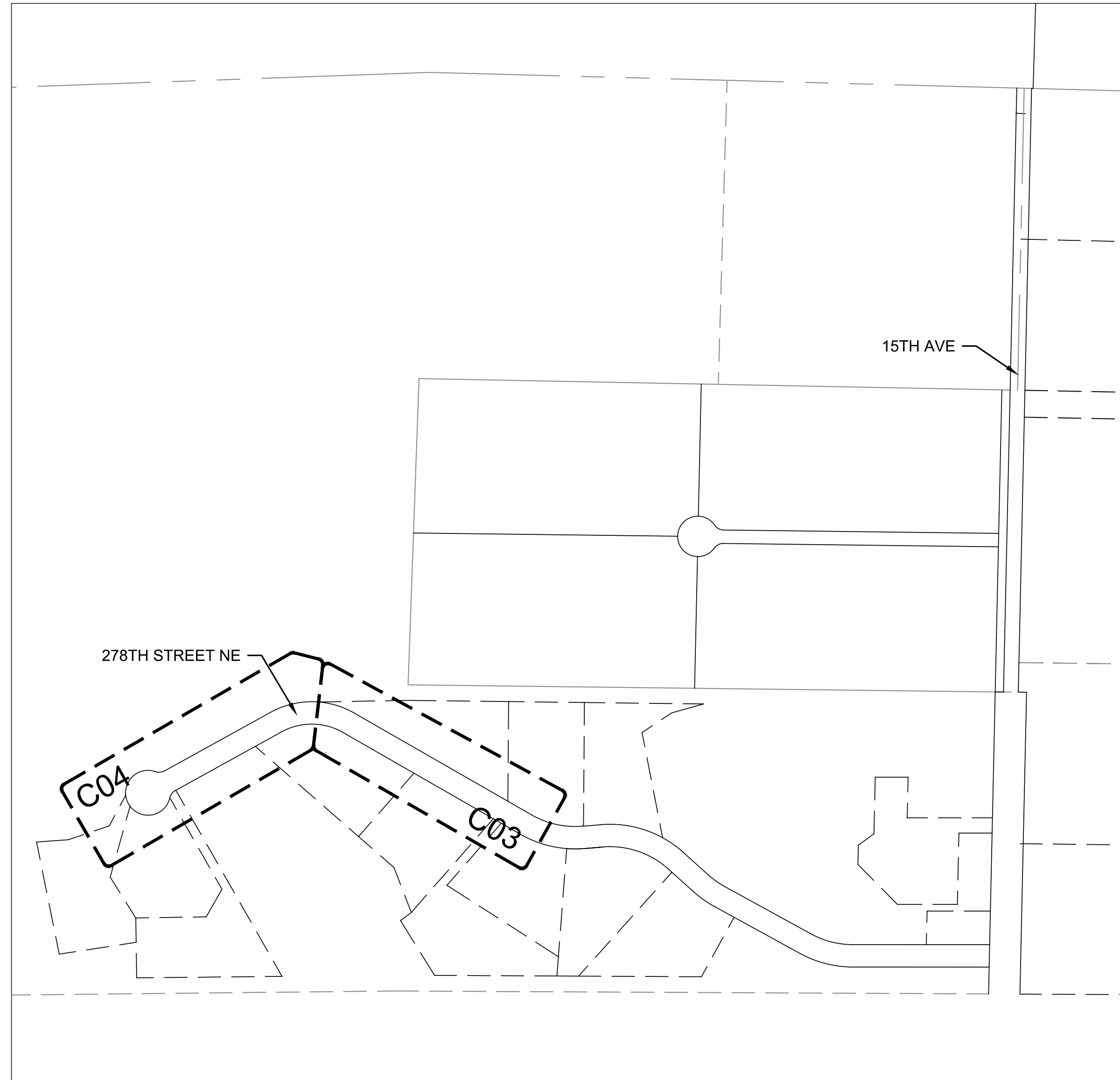

PROJECT INFORMATION:

APPLICANT:
TATOOSH WATER COMPANY
NICK FRANULOVICH
1028 278TH ST NE
ARLINGTON, WA 98223

CIVIL ENGINEER:
JEFFREY M. TASOFF, P.E.
DAVIDO CONSULTING GROUP, INC.
2210 RIVERSIDE DRIVE SUITE 110
MOUNT VERNON, WA 98273

| SHEET INDEX | |
|-------------|------------------------------|
| SHEET | TITLE |
| C01 | COVER SHEET |
| C02 | NOTES |
| C03 | PLAN & PROFILE - 278TH ST NE |
| C04 | PLAN & PROFILE - 278TH ST NE |
| C05 | DETAILS |
| C06 | DETAILS |

| | | | |
|--|--|--------|----------|
| No. | DATE | BY | REVISION |
| | | | |
| | | | |
| LEED ACCREDITED PROFESSIONAL & THE RELATED ACRONYM & THE LEGACLED AP LOGO ARE TRADEMARKS AWARDED TO INDIVIDUALS UNDER LICENSE BY THE GREEN BUILDING CERTIFICATION INSTITUTE. | | | |
| 2210 Riverside Drive Suite 210 Mount Vernon WA 98273 P: 360.889.1110 F: 360.331.5131 www.dgengr.com | | | |
| | | | |
| CALL 811 2 BUSINESS DAYS BEFORE YOU DIG <small>(UNDERGROUND UTILITY LOCATIONS ARE APPROX.)</small> | | | |
| | | | |
| <small>BASE MAP TOPOGRAPHY PROVIDED BY OTHERS. DCG CANNOT BE HELD LIABLE FOR ACCURACY. CONTRACTOR SHALL FIELD VERIFY GRADES, UTILITIES, & ALL OTHER EX FEATURES & CONDITIONS. IF CONDITIONS ARE NOT AS SHOWN, ACR PLANS CANNOT BE CONSTRUCTED AS SHOWN. CONTACT DCG PRIOR TO CONSTRUCTION.</small> | | | |
| OWNER: | NICK FRANULOVICH 1028 278TH ST NE ARLINGTON, WA 98223 | | |
| PROJECT: | TATOOSH WATER COMPANY VIEWMONT ESTATES - DEVELOPER EXTENSION COVER SHEET | | |
| PROJ. MANAGER: | JT | | |
| DESIGNED BY: | RLC | | |
| DRAWN BY: | JS | | |
| CHECKED BY: | JT | | |
| SCALE: | AS SHOWN | | |
| DATE: | REV. | SHEET | |
| 4/13/2020 | A | 1 OF 6 | |
| SHEET NUMBER | | | |
| C01 | | | |

RECEIVED APRIL 27, 2020 WA, UT, & TRANS COMM. ORIGINAL UW-200382

CAD FILE NUMBER: P:\CLIENTS\WATER\TATOOSH\DEVELOPER EXTENSION\DE FRANULOVICH\DRAWING\TATOOSH_VMDE_FRANULOVICH\DWG\TATOOSH_VMDE_FRANULOVICH.DWG
SHEET SET: TATOOSH_VM_DEVI_EXTENSION_FRAN - ORIGINAL SHEET SIZE: ARCH FULL BLEED (24.00 X 36.00) INCHES/AUTOCAD VERSION: CIVIL 3D 2015

WATER NOTES:
REVISED 3/30/2020

- WATER MAINS, VALVES, FITTINGS, HYDRANTS, SERVICES, AND ALL OTHER COMPONENTS SHALL BE INSTALLED AND PRESSURE TESTED IN ACCORDANCE WITH THE STANDARD SPECIFICATIONS FOR ROAD AND BRIDGE AND MUNICIPAL CONSTRUCTION, WASHINGTON STATE DEPARTMENT OF TRANSPORTATION, SECTION 7-09.
- THE CONTRACTOR SHALL GIVE THE TATOOSH WATER COMPANY AND WATER AND WASTEWATER SERVICE (360-466-4443) A MINIMUM OF 72 HOURS NOTICE OF ANY PLANNED CONNECTION TO AN EXISTING PIPELINE. THIS INCLUDES LIVE TAPS. NOTICE IS REQUIRED SO ANY DISRUPTIONS TO EXISTING SERVICES CAN BE SCHEDULED. THE CONTRACTOR SHALL NOTIFY CUSTOMERS INVOLVED OR AFFECTED OF THE WATER SERVICE INTERRUPTION 24 HOURS IN ADVANCE OF THE INTERRUPTION. THE CONTRACTOR SHALL MAKE EVERY EFFORT TO SCHEDULE WATER MAIN CONSTRUCTION WITH A MINIMUM INTERRUPTION OF WATER SERVICE.
- IN CERTAIN SITUATIONS, THE WATER SYSTEM OPERATOR MAY DICTATE SCHEDULING OF WATER MAIN SHUTDOWNS SO AS NOT TO IMPOSE UNNECESSARY SHUTDOWNS DURING SPECIFIC PERIODS TO EXISTING CUSTOMERS.
- ALL WATER MAINS SHALL BE PVC SCH 80 (2" OR LESS), PVC C900, OR DI CLASS 52 PIPE AS SPECIFIED ON THE PLANS. HIGH DENSITY POLYETHYLENE (HDPE) PIPE SDR 9 MAY BE USED IN PLACE OF PVC SPECIFIED ON PLANS. HDPE PIPE SHALL BE BLACK PE 3408 MADE OF NEW RESINS AND MEETING THE REQUIREMENTS OF ASTM D 3350 CELL CLASSIFICATION 345464C, ASTM F714, AWWA C901, AND AWWA C906. PROVISIONS FOR PIPE EXPANSION MUST BE ACCOUNTING FOR WHEN INSTALLING HDPE PIPING.
- WATER MAIN FITTINGS SHALL BE DUCTILE IRON. DUCTILE IRON FITTINGS SHALL MEET THE REQUIREMENTS OF AWWA C153 AND JOINTS SHALL MEET THE REQUIREMENTS OF AWWA C111. DUCTILE IRON FITTINGS SHALL BE CEMENT MORTAR LINED, MEETING THE REQUIREMENTS OF AWWA C104. GASKETS FOR FLAT FACED OR RAISED FACED FLANGES SHALL BE 1/8-INCH THICK NEOPRENE HAVING A DUREMETER OF 60 PLUS OR MINUS 5 OR 1/16-CLOTH INSERTED. THE TYPE, MATERIAL, AND IDENTIFICATION MARK FOR BOLTS AND NUTS SHALL BE PROVIDED. BOLTS, NUTS, AND WASHERS USED FOR SECURING FITTINGS SHALL BE OF SIMILAR MATERIALS. STEEL BOLTS SHALL MEET THE REQUIREMENTS OF ASTM A 307 OR ASTM F 568 FOR CARBON STEEL OR ASTM F 593 OR ASTM F 738 FOR STAINLESS STEEL. NUTS SHALL MEET THE REQUIREMENTS OF ASTM A 563 OR ASTM A 563 FOR CARBON STEEL OR ASTM F 594 OR ASTM F 836 FOR STAINLESS STEEL. IRON BOLTS AND NUTS SHALL MEET THE REQUIREMENTS OF ASTM A 536, GRADE 65-45-12.
- ALL NON-METALLIC PIPE AND SERVICES SHALL BE INSTALLED WITH CONTINUOUS TRACER TAPE INSTALLED 12 TO 18 INCHES UNDER THE FINAL GROUND SURFACE. NO BREAKS OR SPLICES WILL BE ALLOWED. A CONTINUOUS LOOP SHALL BE PLACED FROM THE MAIN LINE TO THE METER BOX AND BACK TO THE MAIN LINE. THE MARKER SHALL BE PLASTIC NON-BIODEGRADABLE, METAL CORE OR BACKING WHICH CAN BE DETECTED BY A STANDARD METAL DETECTOR. TAPE SHALL BE TERRA TAPE "D" OR APPROVED EQUAL. IN ADDITION TO TRACER TAPE, INSTALL 14 GAUGE COATED COPPER WIRE, TAPED TO THE TOP OF PIPE, BROUGHT UP AND TIED OFF AT VALVE BODY.
- THE MINIMUM COVER FOR ALL WATER MAINS FROM TOP OF PIPE TO FINISH GRADE SHALL BE 36 INCHES UNLESS OTHERWISE APPROVED BY THE ENGINEER.
- ALL VALVES AND FITTINGS SHALL BE DUCTILE IRON WITH ANSI FLANGES OR MECHANICAL JOINT ENDS. ALL EXISTING VALVES SHALL BE OPERATED BY DISTRICT PERSONNEL. VALVE BOXES SHALL BE INSTALLED ON ALL BURIED VALVES. THE BOX SHALL BE OF CAST IRON, TWO-PIECE SLIP TYPE, 5-1/4 INCH SHAFT, WITH A BASE CORRESPONDING TO THE SIZE OF THE VALVE. THE COVER SHALL HAVE THE WORD "WATER" CAST IN IT. THE VALVE BOX SHALL BE TYLER PIPE 6855 SERIES OR APPROVED EQUAL. THE COVER SHALL BE A TYLER PIPE STANDARD DROP LID 145325 OR APPROVED EQUAL.
- GATE VALVES, 6 INCH TO 12 INCH. THE DESIGN, MATERIALS AND WORKMANSHIP OF ALL GATE VALVES SHALL CONFORM TO, OR EXCEED THE REQUIREMENTS OF AWWA C509-80 LATEST REVISION. GATES VALVES SHALL BE RESILIENT SEAT NON-RISING STEM (NRS) WITH TWO INTERNAL O-RING STEM SEALS. GATE VALVES SHALL BE MUELLER A-2360. GATE VALVES SHALL BE USED ON ALL 6 TO 12 INCH LINES.
- VALVE BOX. ALL VALVES SHALL HAVE A STANDARD CAST IRON WATER VALVE BOX SET TO GRADE. IF VALVES ARE NOT SET IN PAVED AREA, A 2 FOOT BY 2 FOOT BY 4 INCH CONCRETE PAD SHALL BE SET AROUND EACH VALVE BOX AT FINISHED GRADE. IN AREAS WHERE VALVE BOX FALLS IN ROAD SHOULDER, THE DITCH AND SHOULDER SHALL BE GRADED BEFORE PLACING ASPHALT OR CONCRETE PAD.
- VALVE MARKER POST. VALVE MARKER POSTS SHALL BE 4 INCH X 4 INCH REINFORCED CONCRETE OR SCHEDULE 40 STEEL POSTS 5 FEET LONG, WITH 2 FOOT MINIMUM BURY, STAMPED WITH "W" AND DISTANCE TO VALVE. POST SHALL BE PAINTED WITH 1 BASE COAT AND 2 COATS BLUE OIL BASE ENAMEL.
- ALL FORM RELEASE AGENTS AND ADMIXTURES USED IN THE CONCRETE WORK MUST CONFORM TO NSF 60 REQUIREMENTS.

EROSION AND SEDIMENTATION CONTROL (ESC) NOTES:

- THE CONTRACTOR SHALL MEET SNOHOMISH COUNTY STANDARDS AND REQUIREMENTS BY USING APPROPRIATE BEST MANAGEMENT PRACTICES (BMPs) FOR EROSION AND SEDIMENTATION CONTROL.
- EROSION ON- AND OFF-SITE. DURING AND AFTER CONSTRUCTION, THE CONTRACTOR SHALL MINIMIZE EROSION AND SEDIMENTATION ON-SITE AND SHALL PROTECT PROPERTIES AND WATER COURSES DOWNSTREAM FROM THE SITE FROM EROSION DUE TO INCREASES IN THE VELOCITY AND PEAK FLOW RATE OF STORM WATER RUNOFF FROM THE SITE.
- TRANSPORT OF SEDIMENT. THE CONTRACTOR SHALL PREVENT THE TRANSPORT OF SEDIMENT FROM THE SITE THROUGH MEASURES SUCH AS MULCHING, MATTING, COVERING, SILT FENCES, SEDIMENT TRAPS, SETTLING PONDS AND PROTECTIVE BERMS USING THE FOLLOWING BMPs: FILTER FENCE, STRAW BALE BARRIER, BRUSH BARRIER, GRAVEL FILTER BERM, SEDIMENT TRAP, TEMPORARY SEDIMENT ONTO PAVED SURFACES SHALL BE MINIMIZED, AND IF SEDIMENT IS TRANSPORTED ONTO A PAVED SURFACE, THE PAVED SURFACE SHALL BE CLEANED AT THE END OF EACH DAY IN ACCORDANCE WITH BMPs IN THE DRAINAGE MANUAL, OR APPROVED BY THE DIRECTOR.
- STABILIZING EXPOSED SOIL. THE CONTRACTOR SHALL PREVENT ON-SITE EROSION BY STABILIZING ALL SOILS THAT ARE TEMPORARILY EXPOSED AND NOT BEING ACTIVELY WORKED, THROUGH SUCH METHODS AS THE INSTALLATION OF SEEDING, MULCHING, MATTING AND COVERING. CONTRACTOR SHALL APPLY ONE OR MORE OF THE FOLLOWING TEMPORARY ESC BMPs: TEMP SEEDING, MULCHING AND MATTING, CLEAR PLASTIC COVERING, AND/OR DUST CONTROL.
- DENUDED AREAS SHALL BE STABILIZED AND SOIL STOCKPILES AS ESTABLISHED IN THE DRAINAGE MANUAL.
- STORM DRAIN INLETS SHALL BE PROTECTED USING BMP STORM DRAIN INLET PROTECTION. THE RECOMMENDED INLET PROTECTION ALTERNATIVES ARE TRIANGULAR SILT DIKES; BIOLOGS; EXERTS (FOSS ENVIRONMENTAL); DANDY BAGS; AND, STRAW WATTLES.
- NO MORE THAN THREE HUNDRED (300) FEET OF TRENCH MAY REMAIN OPEN AT ONE TIME. EXCAVATED MATERIAL SHALL BE PLACED ON THE UPHILL SIDE OF TRENCHES, UNLESS INCONSISTENT WITH SAFETY OR SITE CONSTRAINTS.
- DISCHARGE FROM DEWATERING DEVICES. WATER FROM A DEWATERING DEVICE SHALL DISCHARGE INTO A SEDIMENT-RETENTION BMP.
- MAINTENANCE AND REPAIR OF EROSION AND SEDIMENTATION CONTROL MEASURES. THE CONTRACTOR SHALL MAINTAIN AND REPAIR AS NECESSARY ALL TEMPORARY AND PERMANENT EROSION AND SEDIMENTATION CONTROL BMPs TO ASSURE THEIR CONTINUED PERFORMANCE.
- TEMPORARY EROSION AND SEDIMENTATION CONTROL MEASURES SHALL BE MAINTAINED UNTIL FINAL SITE STABILIZATION.

UNANTICIPATED DISCOVERY PLAN:



- IF EARTH DISTURBING ACTIVITIES DURING PROJECT CONSTRUCTION UNCOVER CULTURAL MATERIALS (I.E. STRUCTURAL REMAINS, HISTORIC ARTIFACTS, OR PREHISTORIC ARTIFACTS), ALL WORK SHALL CEASE AND THE WASHINGTON STATE ARCHAEOLOGIST AT THE DEPARTMENT OF ARCHAEOLOGY AND HISTORIC PRESERVATION (DAHPP) AND THE CULTURAL RESOURCES PROGRAM OF THE STILLAGUAMISH TRIBE SHALL BE NOTIFIED IMMEDIATELY.
- IF HUMAN REMAINS ARE UNCOVERED, ALL WORK SHALL CEASE IMMEDIATELY IN ACCORDANCE WITH THE NATIVE AMERICAN GRAVES PROTECTION AND REPATRIATION ACT OF 1990 (NAGPRA) AND WASHINGTON STATE STATUTES RCW 27.44. THE AREA AROUND THE DISCOVERY SHALL BE SECURED AND THE COUNTY CORONER AND THE STATE ARCHEOLOGIST AT DAHP SHALL BE NOTIFIED IMMEDIATELY. THE STATE ARCHEOLOGIST SHALL NOTIFY RD SEC AND SWINOMISH AND TULALIP TRIBES.
- CONSTRUCTION SHALL BE HALTED OR SHIFTED TO A NEW LOCATION PENDING THE NOTIFICATION PROCESS AND FURTHER INSTRUCTIONS ISSUED BY THE AGENCY AFTER CONSULTATION WITH THE STATE HISTORIC PRESERVATION OFFICE, STILLAGUAMISH AND TULALIP TRIBES, AND OTHER APPROPRIATE AUTHORITIES.

GENERAL NOTES:

- THE CONTRACTOR SHALL NOTIFY JURISDICTION A MINIMUM OF 24 HOURS PRIOR TO STARTING ANY WORK.
- THE CONTRACTOR SHALL NOTIFY THE UNDERGROUND UTILITY LOCATE CENTER AT 1-800-424-5555 AT LEAST 48 HOURS PRIOR TO CONSTRUCTION.
- THE CONTRACTOR SHALL PROTECT IN PLACE, ALL UTILITIES, STRUCTURES AND FEATURES, WHETHER OR NOT SHOWN ON THESE PLANS. ANY DAMAGE TO EXISTING UTILITIES OR FEATURES SHALL BE REPAIRED AT THE CONTRACTOR'S EXPENSE.
- LOCATIONS OF EXISTING FEATURES AND UTILITIES AS SHOWN ON THESE DRAWINGS ARE APPROXIMATE AND BASED ON THE BEST AVAILABLE INFORMATION. ACTUAL LOCATIONS SHALL BE DETERMINED BY THE CONTRACTOR.
- THE CONTRACTOR SHALL BE RESPONSIBLE FOR THE MEANS, METHODS AND SEQUENCE OF CONSTRUCTION.
- ALL WORK SHALL CONFORM TO CURRENT APPROVED STANDARD PLANS AND WSDOT/APWA STANDARD SPECIFICATIONS FOR ROAD, BRIDGE, AND MUNICIPAL CONSTRUCTION.
- THE CONTRACTOR SHALL BE REQUIRED TO KEEP ACCURATE AS-BUILT DRAWINGS AND DELIVER THIS INFORMATION TO THE OWNER FOR PREPARATION OF AS-BUILT DRAWINGS.
- WATER MAINS SHALL BE PROPERLY DISINFECTED, FLUSHED, AND HAVE A SATISFACTORY BACTERIOLOGICAL TEST RESULTS FROM A WATER SAMPLE COLLECTED FROM THE PIPE BEFORE ENTERING SERVICE.
- UTILITY SERVICE INTERRUPTIONS SHALL NOT EXCEED TWO HOURS.
- 24 HOUR NOTICE SHALL BE PROVIDED TO ALL PROPERTY OWNERS/OCCUPANTS OF ANY UTILITY SERVICE OR ACCESS INTERRUPTIONS.
- ONE LANE TRAFFIC MUST BE MAINTAINED AT ALL TIMES ON COUNTY ROADS. ROAD CLOSURES WILL NOT BE ALLOWED UNLESS EXPRESSLY AUTHORIZED AND APPROVED BY ISLAND COUNTY.
- PROPER SIGNAGE AND FLAGGERS ARE REQUIRED PER THE MUTCD. FLAGGERS SHALL HAVE CURRENT CARDS INDICATING THAT THEY ARE QUALIFIED TO PERFORM THE REQUIRED TRAFFIC CONTROL.
- ACCESS TO PRIVATE PROPERTY SHALL BE RESTORED DAILY.
- STREETS SHALL BE SWEEPED DAILY OR AS NEEDED.

ENVIRONMENTAL NOTES:

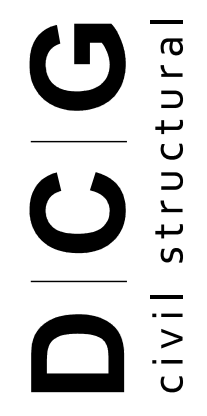
- EQUIPMENT MUST MEET CURRENT STATE OF WASHINGTON REGULATIONS FOR NOISE. NOISE PRODUCING EQUIPMENT WILL BE LOCATED IN ENCLOSURES WITH ACOUSTIC PANELS DESIGNED TO REDUCE NOISE.
- CONSTRUCTION ACTIVITIES WILL BE SCHEDULED TO REDUCE TRAFFIC, DUST AND NOISE IMPACTS IN RESIDENTIAL AREAS.
- THE APPLICANT SHALL OBTAIN ANY NECESSARY PERMITS FROM LOCAL AND OTHER GOVERNMENTAL AGENCIES.
- WORK IN PUBLIC RIGHT-OF-WAYS SHALL HAVE ALL NECESSARY PERMITS.
- WORK ON THIS PROJECT SHALL BE NO EARLIER THAN TWO HOURS AFTER SUNRISE AND NO LATER THAN TWO HOURS BEFORE SUNSET TO ACCOMMODATE LOCAL NESTING BALD EAGLES.

| | |
|--|--|
|  | |
| 2210 Riverside Drive Suite 210 Mount Rainier WA 98273 P: 360.889.1110 F: 360.331.5131 www.dcgengr.com | |
|  | |
| CALL 811 2 BUSINESS DAYS BEFORE YOU DIG <small>(UNDERGROUND UTILITY LOCATIONS ARE APPROX.)</small> | |
|  | |
| <small>BASE MAP TOPOGRAPHY PROVIDED BY OTHERS. DCG CANNOT BE HELD LIABLE FOR ACCURACY. CONTRACTOR SHALL FIELD VERIFY GRADES, UTILITIES, & ALL OTHER EX FEATURES & CONDITIONS. IF CONDITIONS ARE NOT AS SHOWN & OR PLANS CANNOT BE CONSTRUCTED AS SHOWN, CONTACT DCG PRIOR TO CONSTRUCTION.</small> | |
| OWNER: NICK FRANULOVICH 1028 278TH ST NE ARLINGTON, WA 98223 | PROJECT: TATOOSH WATER COMPANY VIEWMONT ESTATES - DEVELOPER EXTENSION NOTES |
| PROJ. MANAGER: JT DESIGNED BY: RLC DRAWN BY: JS CHECKED BY: JT | SCALE: AS SHOWN DATE: 4/13/2020 REV. A SHEET 2 OF 6 |
| SHEET NUMBER C02 | |

A B C D E F G H I J K

1 2 3 4 5 6 7 8

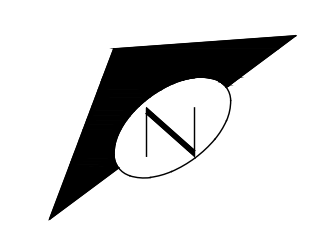

LEGEND:

- ESMT — EXISTING PUBLIC UTILITY EASEMENT
- EXISTING RIGHT OF WAY



MATCHLINE STA 17+30 SEE SHEET C04

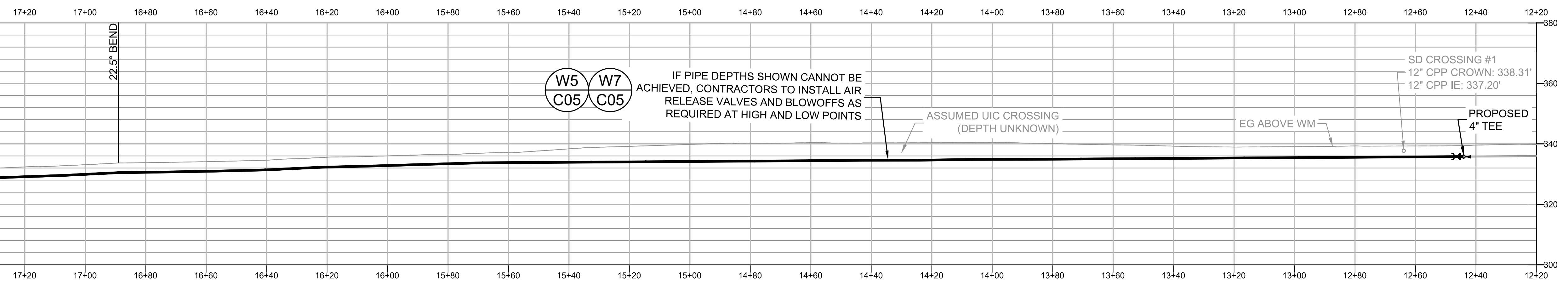

PROFILE
SCALE: H.1"=20'; V.1"=20'



GENERAL NOTE:

1. UNDERGROUND UTILITIES ARE NOT SHOWN. OBTAIN A UTILITY LOCATE AND ADJUST WATERLINE LAYOUT AS NEEDED TO AVOID UTILITIES.
2. EXISTING STORM PIPE DEPTHS SHOWN ARE APPROXIMATE. ADJUST WATERLINE DEPTHS AS NECESSARY TO MAINTAIN MIN 30" COVER AND 3" VERTICAL SEPARATION FROM STORM PIPE

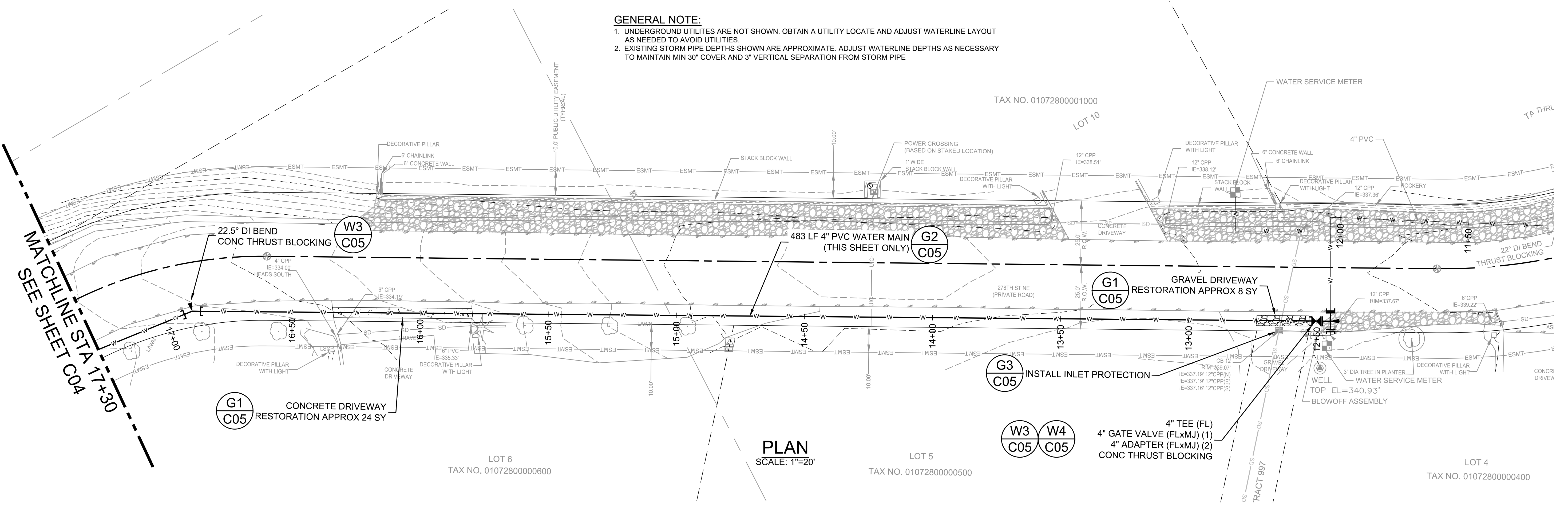

PLAN
SCALE: 1"=20'

MATCHLINE STA 17+30
SEE SHEET C04

| <p>2210 Riverside Drive Suite 210 Mesa, WA 98275 P: 360.899.1110 F: 360.331.5131 www.dcgengr.com</p> | <p>LEED ACCREDITED PROFESSIONAL & THE RELATED ACRONYM & THE LEGACIES OF LEED ARE TRADEMARKS OF THE U.S. GREEN BUILDING INSTITUTE AWARDED TO INDIVIDUALS UNDER LICENSE BY THE GREEN BUILDING CERTIFICATION INSTITUTE.</p> | <p>REVISION</p> <table border="1" style="width: 100%; border-collapse: collapse;"> <tr> <th>No.</th> <th>DATE</th> <th>BY</th> </tr> <tr> <td> </td> <td> </td> <td> </td> </tr> </table> | No. | DATE | BY | | | | <p>CALL 811 2 BUSINESS DAYS BEFORE YOU DIG <small>(UNDERGROUND UTILITY LOCATIONS ARE APPROX.)</small></p> | <p>JEFFREY M. TATOOOSH PROFESSIONAL ENGINEER 41424</p> | <p>BASE MAP TOPOGRAPHY PROVIDED BY OTHERS. DCG CANNOT BE HELD LIABLE FOR ACCURACY. CONTRACTOR SHALL FIELD VERIFY GRADES, UTILITIES, & ALL OTHER EX FEATURES & CONDITIONS. IF CONDITIONS ARE NOT AS SHOWN, BIDS PLANS CANNOT BE CONSTRUCTED AS SHOWN. CONTACT DCG PRIOR TO CONSTRUCTION.</p> | <p>OWNER: NICK FRANULOVICH 1028 278TH ST NE ARLINGTON, WA 98223</p> <p>PROJECT: TATOOOSH WATER COMPANY VIEWMONT ESTATES - DEVELOPER EXTENSION PLAN & PROFILE - 278TH ST NE</p> <p>PROJ. MANAGER: JT DESIGNED BY: RLC DRAWN BY: JS CHECKED BY: JT</p> <p>SCALE: AS SHOWN DATE: 4/13/2020 REV: A SHEET: C03 OF: 3</p> <p>SHEET NUMBER C03</p> |
|--|--|---|-----|------|----|--|--|--|---|---|---|--|
| No. | DATE | BY | | | | | | | | | | |
| | | | | | | | | | | | | |

RECEIVED APRIL 27, 2020 WA. UT. & TRANS COMM. ORIGINAL UW-200382
 CAD FILE NUMBER: P:\CLIENTS\WATER\TATOOOSH\DEVELOPER\EXTENSION\DRAWING\TATOOOSH_VMDE_FRANULOVICH\DWG\TATOOOSH_VMDE_FRANULOVICH\DWG\TATOOOSH_VMDE_FRANULOVICH\DWG\TATOOOSH_VMDEV_EXTENSION_FRANULOVICH.dwg
 SHEET SET: TATOOOSH_VMDEV_EXTENSION_FRANULOVICH.dwg
 ORIGINAL SHEET SIZE: ARCH FULL BLEED D (24.00 X 36.00) INCHES/AUTOCAD VERSION: CIVIL 3D 2015

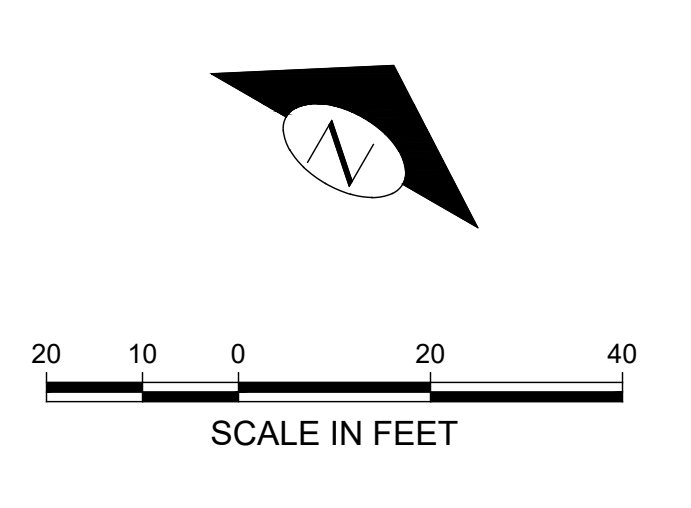

LEGEND:
 — ESMT — EXISTING PUBLIC UTILITY EASEMENT
 — EXISTING RIGHT OF WAY

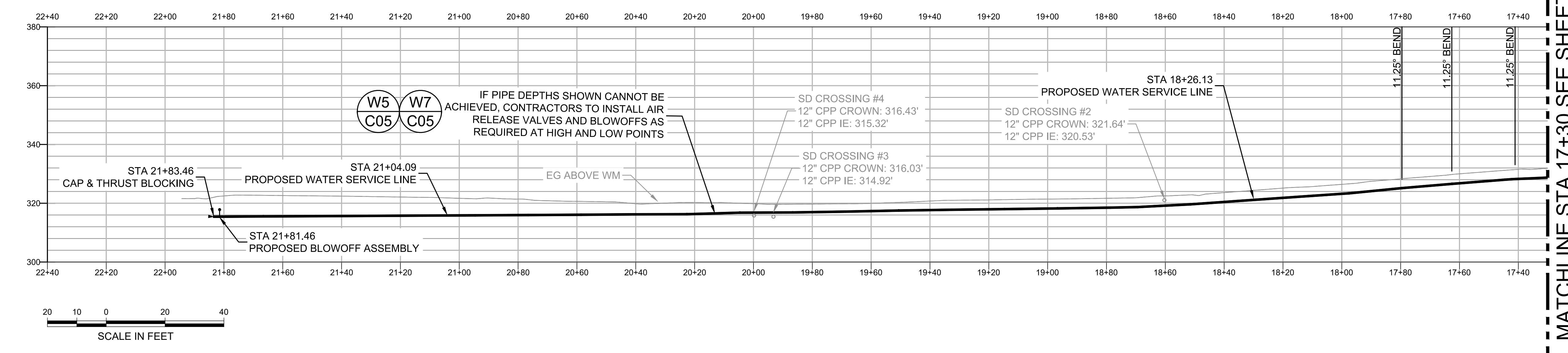
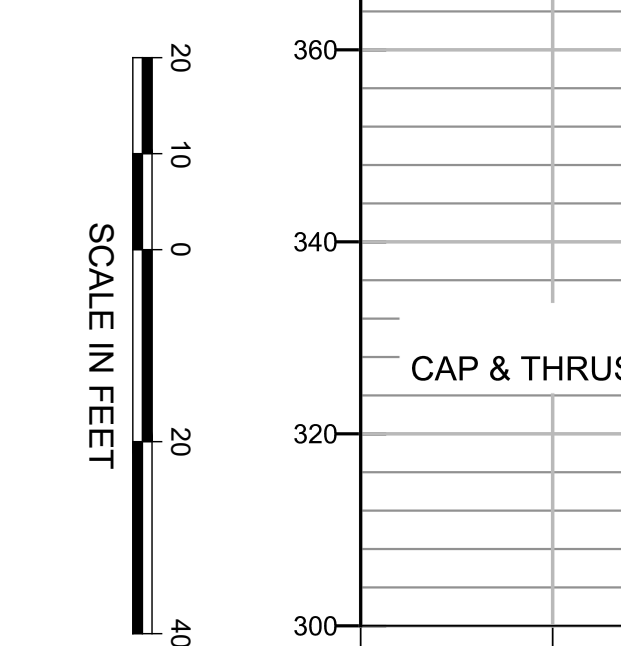

PROFILE
 SCALE: H.1"=20'; V.1"=20'

GENERAL NOTE:
 1. UNDERGROUND UTILITIES ARE NOT SHOWN. OBTAIN A UTILITY LOCATE AND ADJUST WATERLINE LAYOUT AS NEEDED TO AVOID UTILITIES.
 2. EXISTING STORM PIPE DEPTHS SHOWN ARE APPROXIMATE. ADJUST WATERLINE DEPTHS AS NECESSARY TO MAINTAIN MIN 30" COVER AND 3" VERTICAL SEPARATION FROM STORM PIPE

TAX NO. 01072800099900

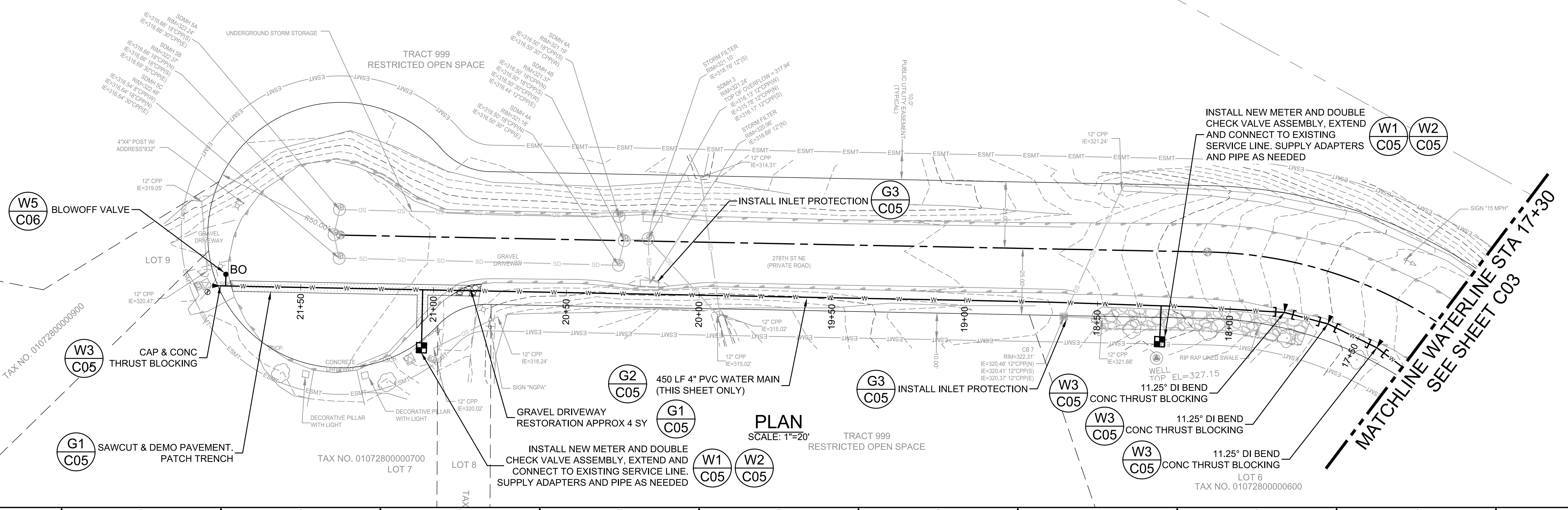

PLAN
 SCALE: 1"=20'

MATCHLINE WATERLINE STA 17+30
 SEE SHEET C03

| No. | DATE | BY | REVISION |
|-----|------|----|----------|
| | | | |

2210 Riverside Drive
 Suite 210
 Meriden, WA 98275
 P: 360 889 1110
 F: 360 331 5131
 www.dcgengr.com

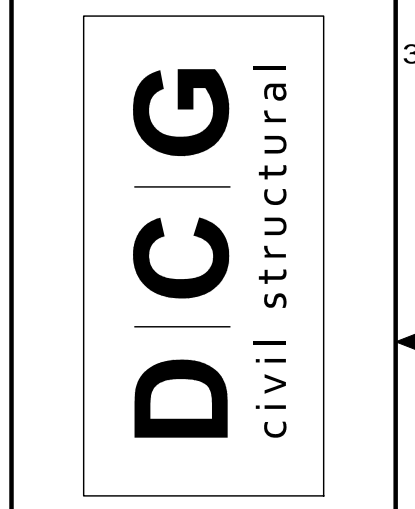

CALL 811
 2 BUSINESS DAYS
 BEFORE YOU DIG
 (UNDERGROUND UTILITY LOCATIONS ARE APPROX.)



BASE MAP TOPOGRAPHY PROVIDED BY OTHERS. DCG CANNOT BE HELD LIABLE FOR ACCURACY. CONTRACTOR SHALL FIELD VERIFY GRADES, UTILITIES, & ALL OTHER EX FEATURES & CONDITIONS. IF CONDITIONS ARE NOT AS SHOWN, OUR PLANS CANNOT BE CONSTRUCTED AS SHOWN. CONTACT DCG PRIOR TO CONSTRUCTION.

| | |
|---|--|
| OWNER: NICK FRANULOVICH 1028 278TH ST NE ARLINGTON, WA 98223 | PROJECT: TATOOOSH WATER COMPANY VIEWMONT ESTATES - DEVELOPER EXTENSION PLAN & PROFILE - 278TH ST NE |
| PROJ. MANAGER: JT | DESIGNED BY: RLC |
| DRAWN BY: JS | CHECKED BY: JT |
| SCALE: AS SHOWN | DATE: 4/13/2020 |
| REV A | SHEET C04 |
| SHEET NUMBER C04 | |

LEED ACCREDITED PROFESSIONAL & THE RELATED ACRONYMS & THE LEGACIES OF LEED ARE TRADEMARKS AWARDED TO INDIVIDUALS UNDER LICENSE BY THE GREEN BUILDING CERTIFICATION INSTITUTE.

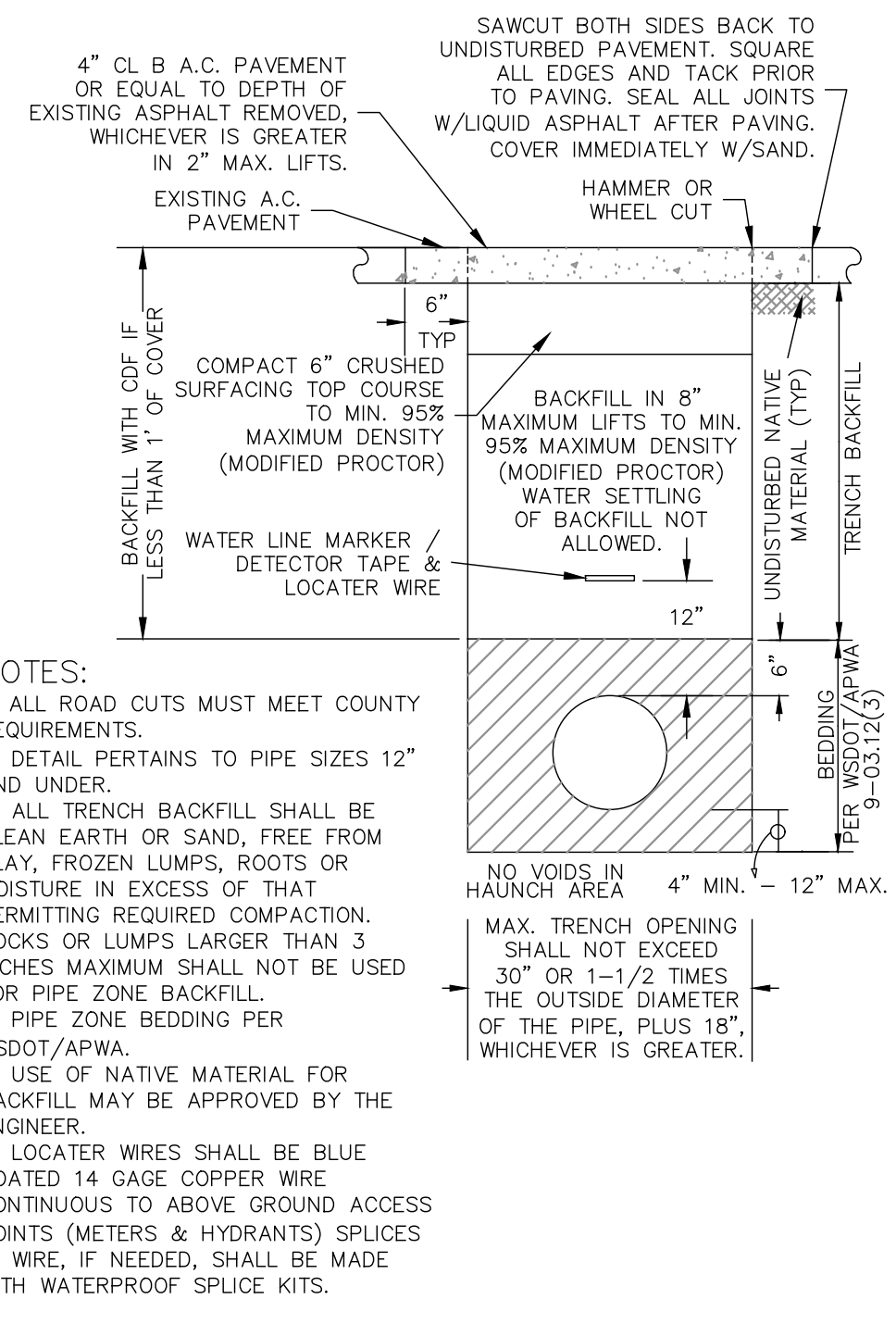

TYPICAL TRENCH PAVEMENT
NTS
G1
C03 & C04

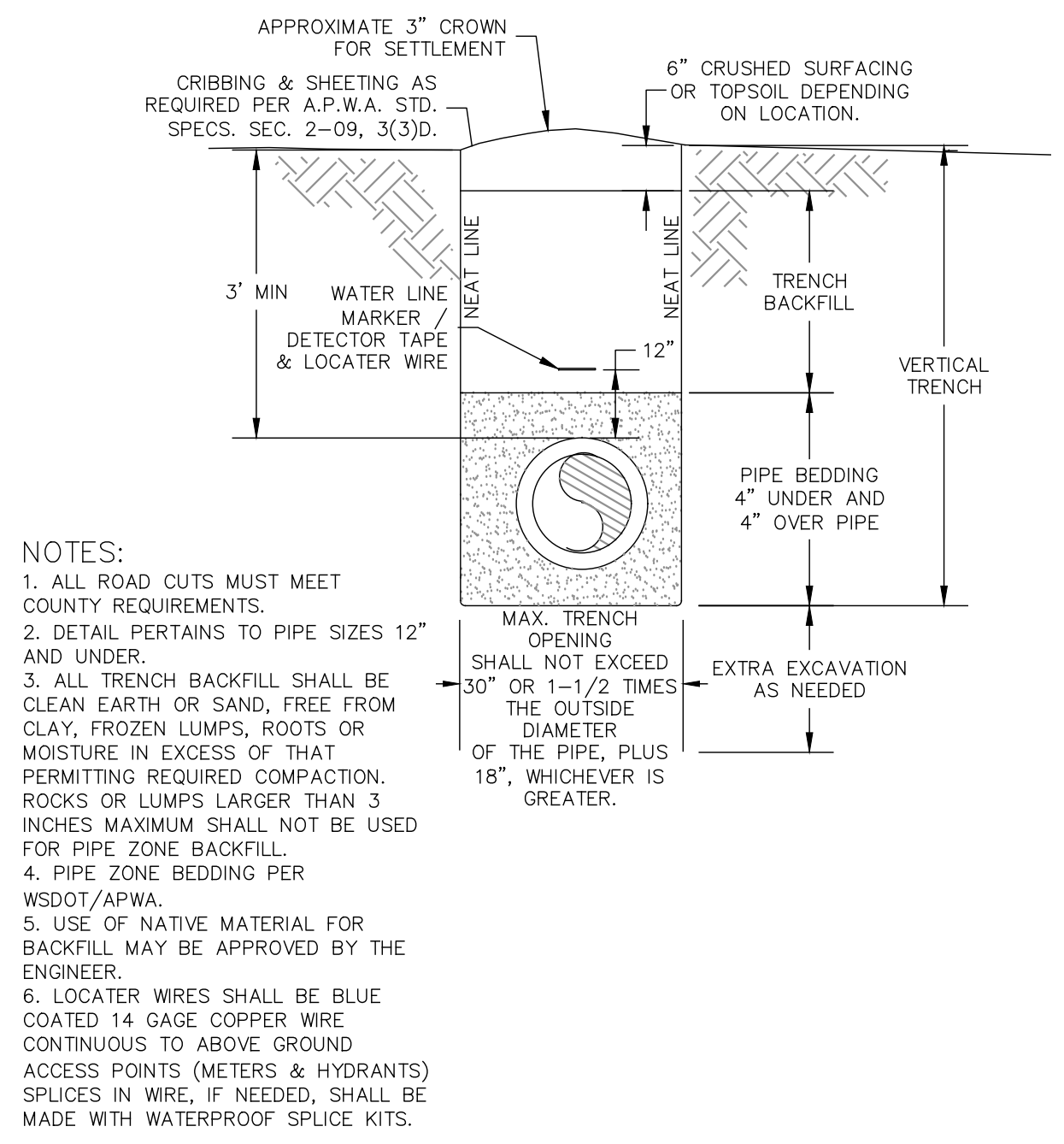

TYPICAL TRENCH NON - PAVEMENT
NTS
G2
C03 & C04

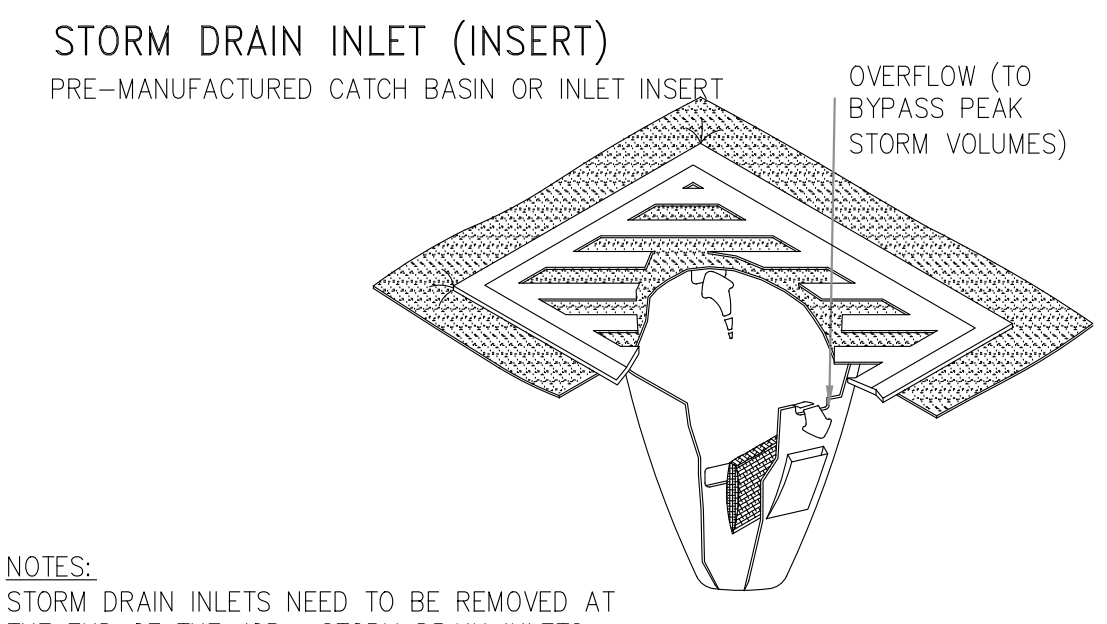

STORM DRAIN INLET (INSERT)
PRE-MANUFACTURED CATCH BASIN OR INLET INSERT
OVERFLOW (TO BYPASS PEAK STORM VOLUMES)
G3
C03 & C04

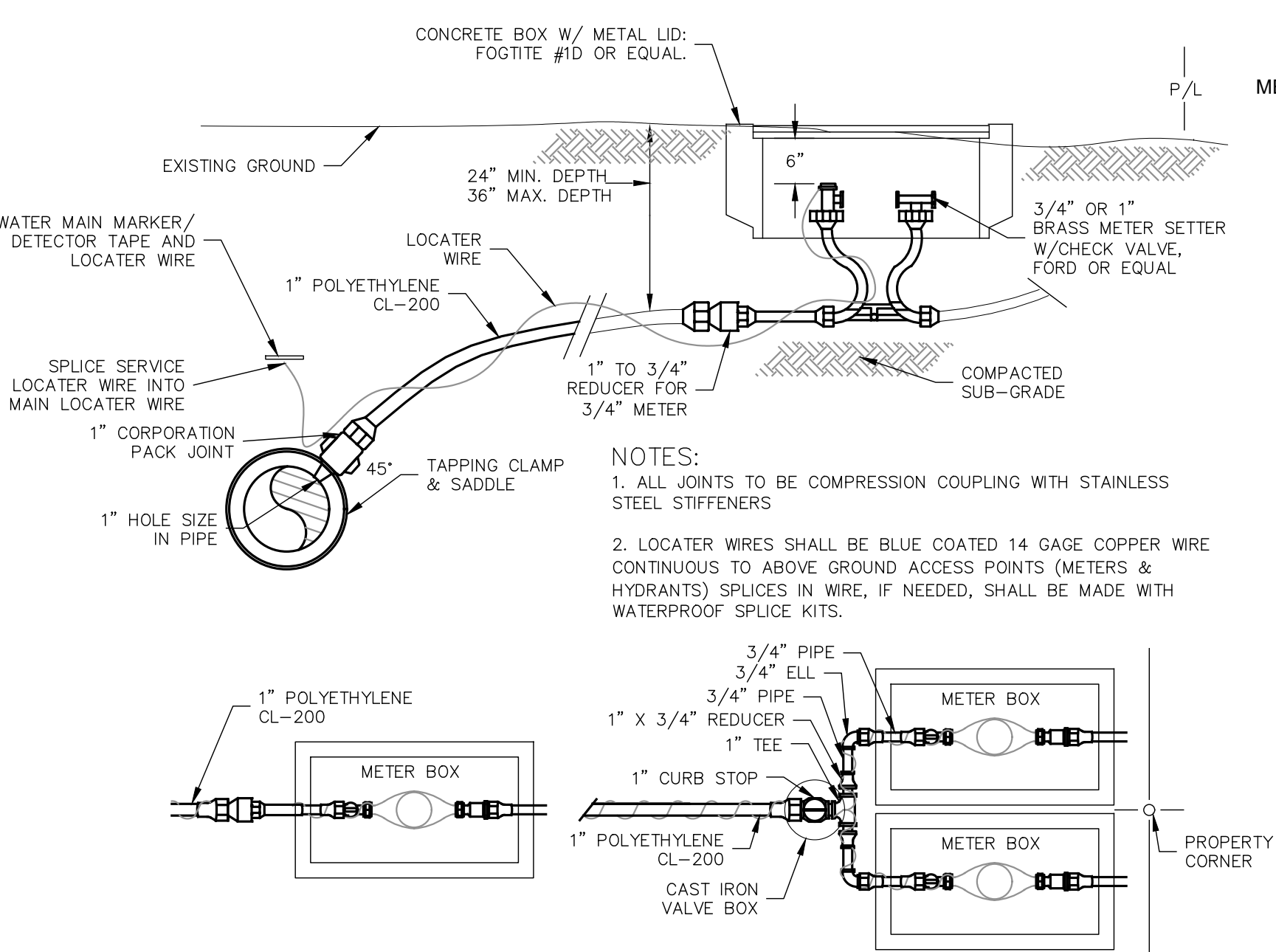

WATER METER
NTS
W1
C04

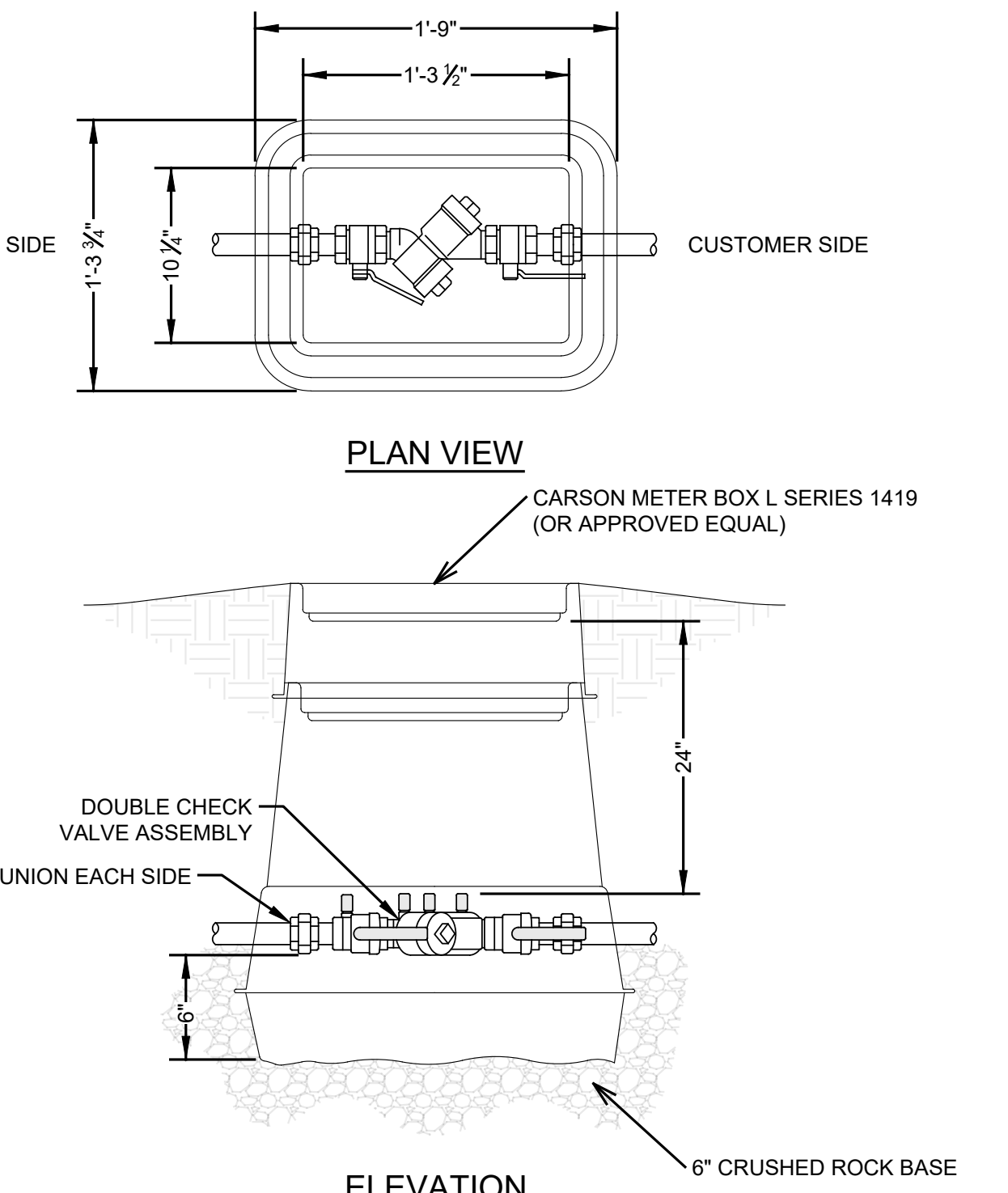

DOUBLE CHECK VALVE ASSEMBLY
NTS
W2
C04

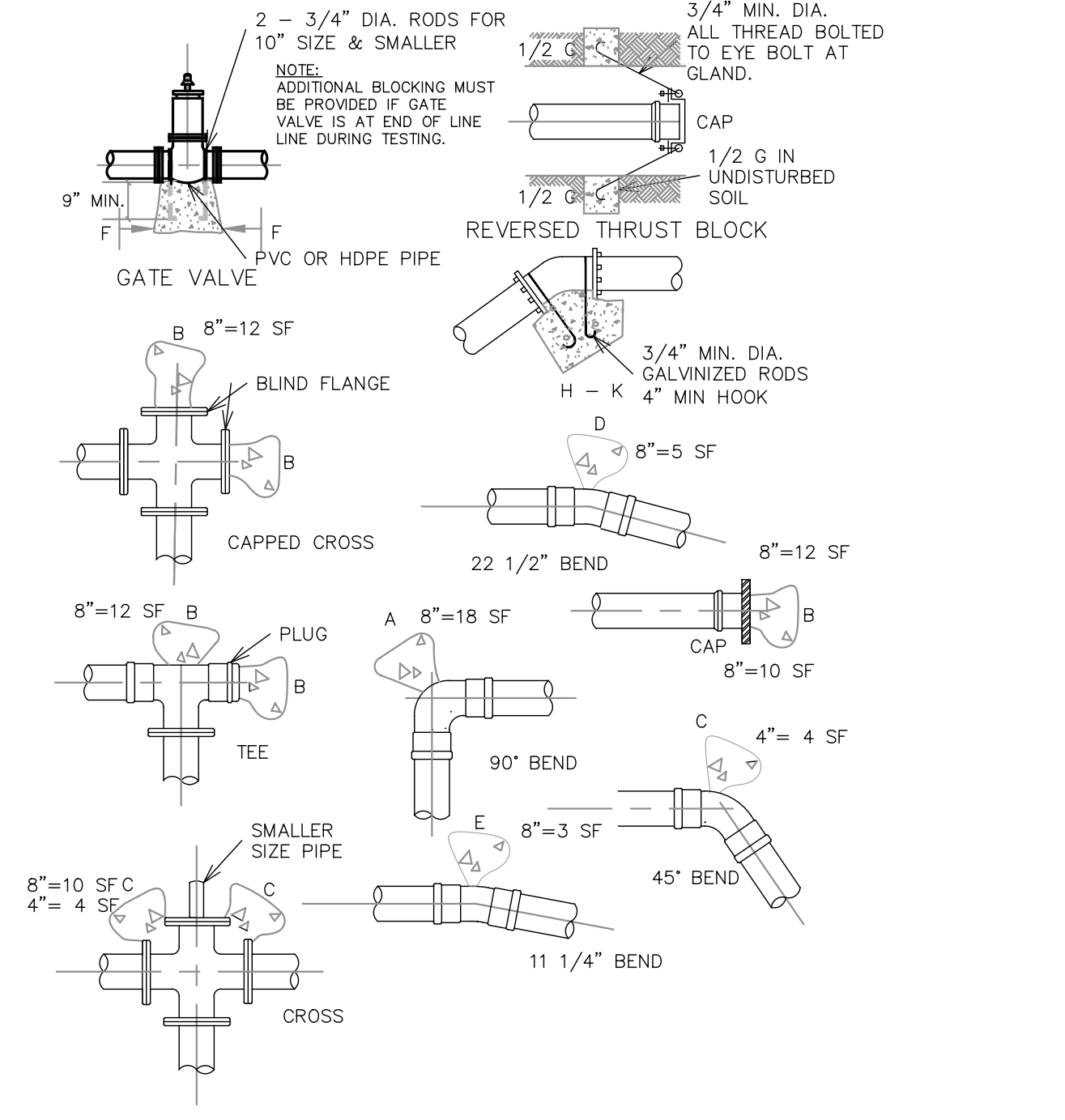

NOTE: SEE THRUST BLOCK TABLE, DETAIL PROVIDE POLYETHYLENE SHEETING TO COVER BOLTS AND JOINTS FOR DISMANTLING.

| PIPE SIZE (SF) | MIN. BEARING AREA AGAINST UNDISTURBED SOIL SQUARE FEET (SF) | | | | REV. 'B | VERTICAL THRUST BLOCKING (CY) | | | |
|----------------|---|---------------|---------------------|-----------|---------|-------------------------------|------|--------|---------|
| | TEEC - 45°D | TEEC - 22.5°E | TEEC - 11.25°F - GV | TEEC - 0° | | H - 90°I | 45°J | 22.5°K | 11.25°L |
| 4" | 4 | 4 | 4 | 4 | 6 | 2 | 1 | 1 | 1 |
| 6" | 10 | 7 | 6 | 6 | 6 | 2 | 1 | 1 | 1 |
| 8" | 18 | 12 | 10 | 10 | 6 | 2 | 1 | 1 | 1 |
| 10" | 24 | 22 | 14 | 8 | 6 | 2 | 1 | 1 | 1 |

- NOTES:
- BEARING AREA OF CONC. THRUST-BLOCK BASED ON 250 PSI PRESSURE AND SAFE SOIL BEARING LOAD OF 1,000 POUNDS PER SQUARE FOOT.
 - AREAS MUST BE ADJUSTED FOR OTHER PIPE SIZES, PRESSURES AND SOIL CONDITIONS.
 - CONCRETE BLOCKING SHALL BE CAST IN PLACE AND HAVE A MINIMUM OF 36 SQ. INCHES BEARING AGAINST THE FITTING.
 - BLOCK SHALL BEAR AGAINST FITTINGS ONLY AND SHALL BE CLEAR OF JOINTS TO PERMIT TAKING UP OR DISMANTLING OF JOINT.
 - CONTRACTORS SHALL INSTALL BLOCKING ADEQUATE TO WITHSTAND FULL TEST PRESSURE AS WELL AS TO CONTINUOUSLY WITHSTAND OPERATION TEST AT 250 PSI AT LOWEST POINT.
 - PROVIDE PLASTIC SHEETING TO COVER FITTINGS, VALVES, AND FOR DISMANTLING.

WATER MAIN THRUST BLOCKING
NTS
W3
VARIES

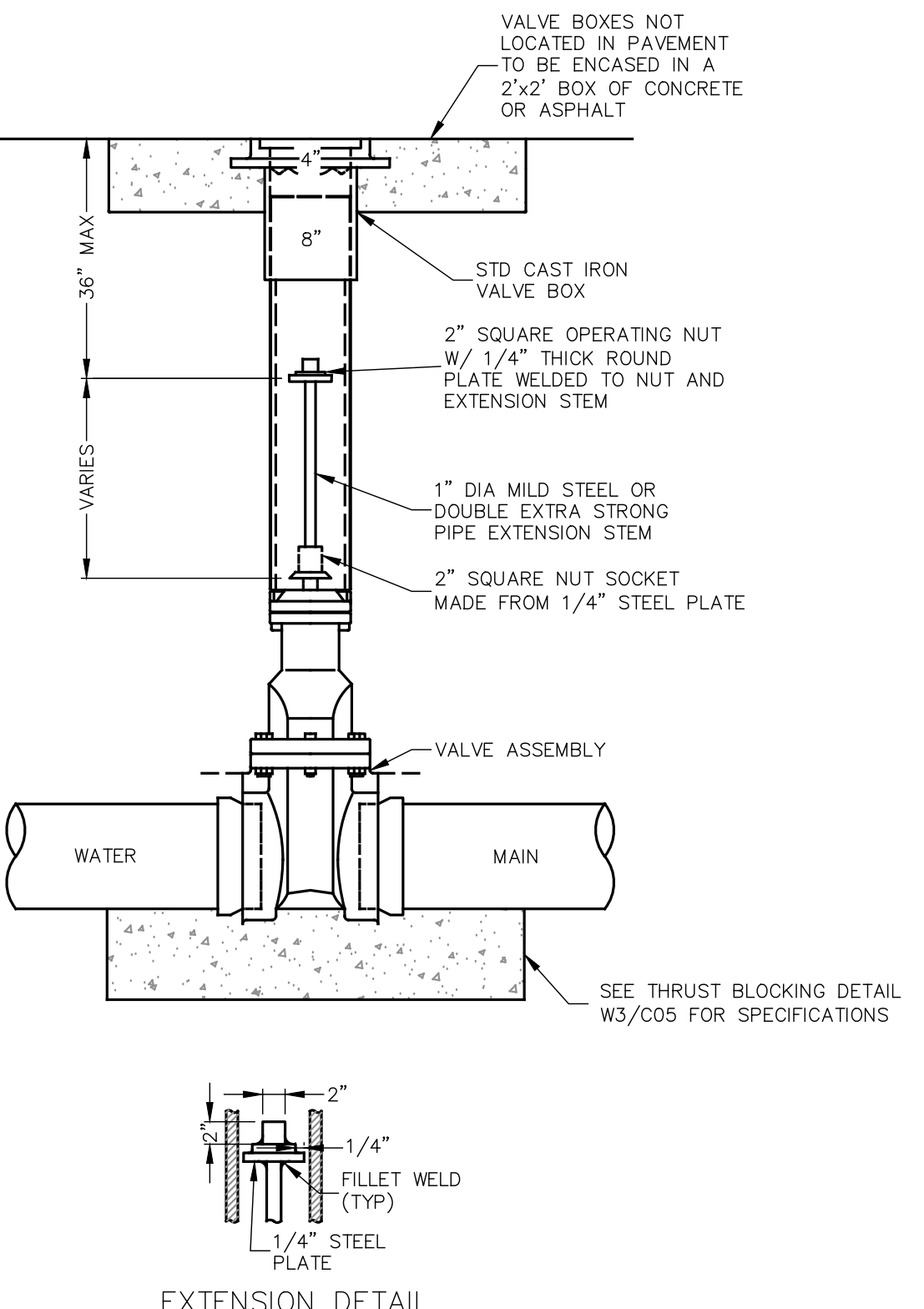

WATER VALVE EXTENSION
NTS
W4
C03 & C04

| | | | |
|----------|----|------|-----|
| REVISION | BY | DATE | No. |
| | | | |
| | | | |
| | | | |

2210 Riverside Drive
Suite 210
Mesa, WA 98275
P: 360.889.1110
F: 360.331.5131
www.dcgengr.com

DCG
civil structural

CALL 811
2 BUSINESS DAYS
BEFORE YOU DIG
(UNDERGROUND UTILITY LOCATIONS ARE APPROX.)

JEFFREY M. TASOFF
STATE OF WASHINGTON
REGISTERED
PROFESSIONAL ENGINEER
1424

BASE MAP TOPOGRAPHY PROVIDED BY OTHERS. DCG CANNOT BE HELD LIABLE FOR ACCURACY. CONTRACTOR SHALL FIELD VERIFY GRADES, UTILITIES, & ALL OTHER EX FEATURES & CONDITIONS. IF CONDITIONS ARE NOT AS SHOWN, WORK PLANS CANNOT BE CONSTRUCTED AS SHOWN. CONTACT DCG PRIOR TO CONSTRUCTION.

OWNER: NICK FRANULOVICH
1028 278TH ST NE
ARLINGTON, WA 98223

PROJECT: TATOOOSH WATER COMPANY
VIEWMONT ESTATES - DEVELOPER EXTENSION

DETAILS

PROJ. MANAGER: JT
DESIGNED BY: RLC
DRAWN BY: JS
CHECKED BY: JT

SCALE: AS SHOWN

DATE: 4/13/2020
REV: A
SHEET: 5
OF: 6

SHEET NUMBER
C05

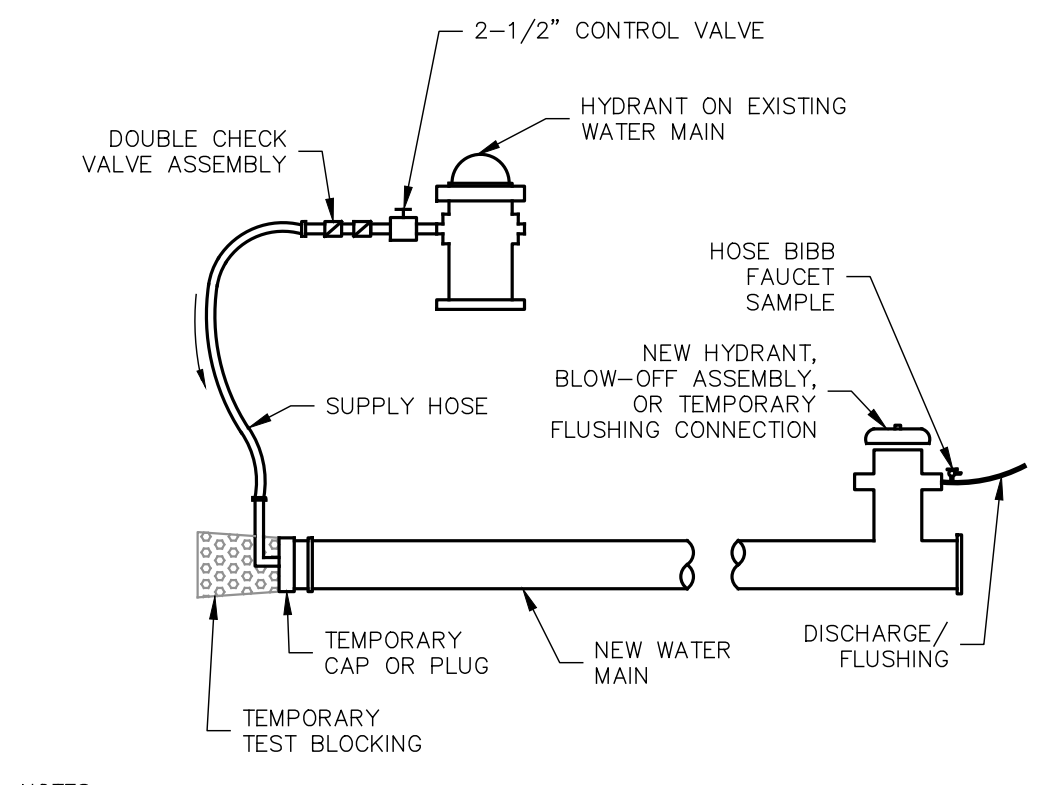
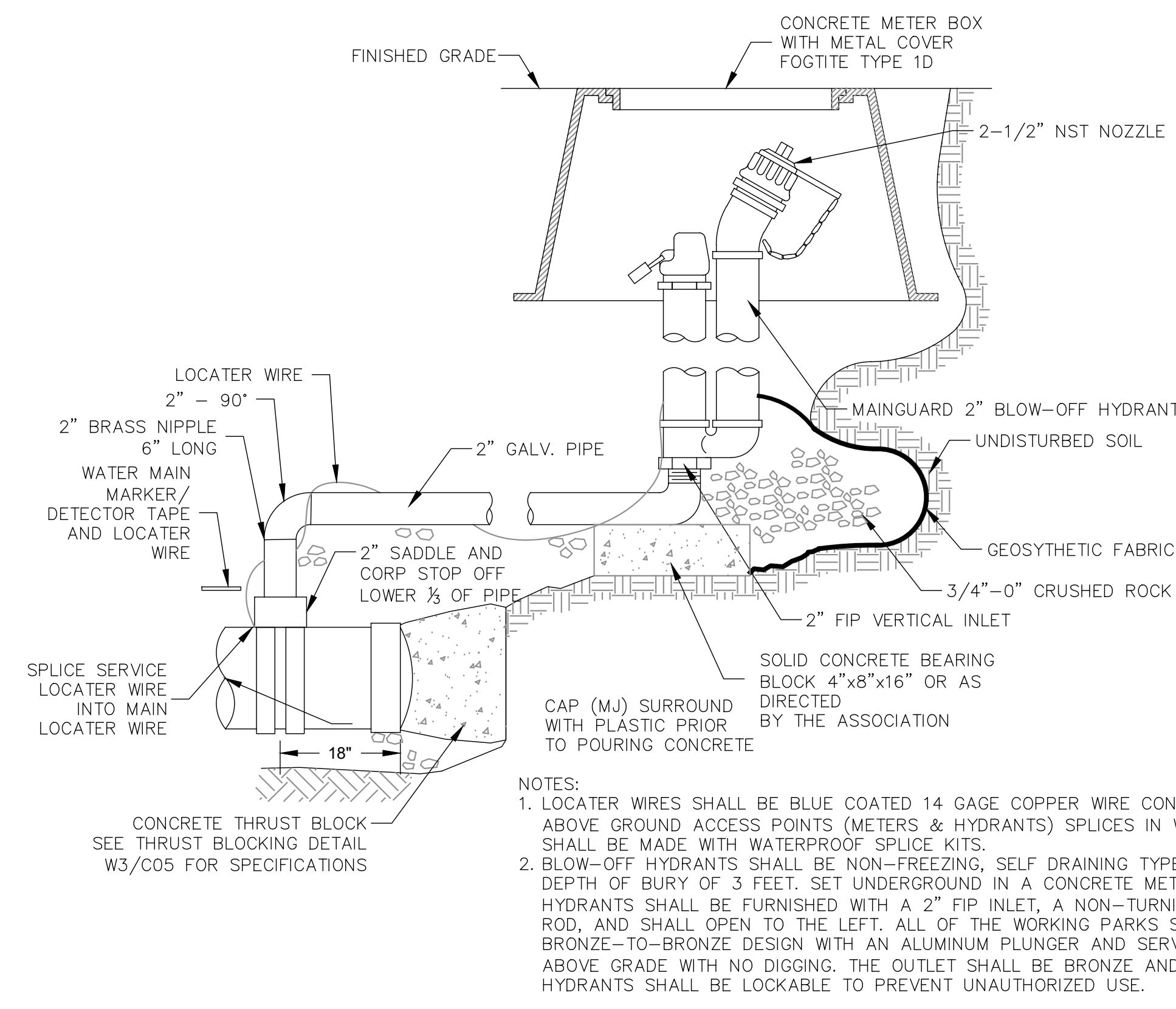

- NOTES:**
- 1 THE FILLING OF MAINS SHALL BE DONE ONLY UNDER THE SUPERVISION OF THE WATER COMPANY.
 - 2 AN APPROVED BACKFLOW PREVENTION ASSEMBLY SHALL BE INSTALLED BETWEEN THE EXISTING AND NEW WATER LINES DURING DISINFECTION AND FLUSHING OF NEW WATERMAIN.
 - 3 THE BACKFLOW PREVENTION ASSEMBLY AND SUPPLY HOSE MUST BE DISCONNECTED DURING HYDROSTATIC PRESSURE TESTING OF THE NEW MAIN.
 - 4 THE NEW WATERMAIN SHALL BE CONNECTED TO THE EXISTING SYSTEM ONLY AFTER NEW MAIN IS FLUSHED, DISINFECTED AND SATISFACTORY BACTERIOLOGICAL SAMPLE RESULTS ARE OBTAINED.
 - 5 THE INTERIORS OF ALL PIPES AND FITTINGS TO BE USED IN FINAL CONNECTION MUST BE SWABBED OR SPRAYED WITH A 5% AVAILABLE CHLORINE SOLUTION.

- NOTES:**
- A. AIR-N-VAC UNIT AND BOX SHALL BE INSTALLED IN A NON-TRAFFIC AREA.
 - B. SADDLE FOR AIR-N-VAC UNIT SHALL BE INSTALLED AT THE HIGH POINT OF THE LINE. IF HIGH POINT FALLS IN LOCATION WHERE ASSEMBLY CANNOT BE INSTALLED, INSTALL WATER MAIN TO CREATE A HIGH POINT WHERE AIR-N-VAC CAN BE LOCATED.
 - C. ALL PIPE AND FITTINGS SHALL BE MINIMUM PRESSURE CLASS 200 PSI, IPS SIZE. ALL FITTINGS BETWEEN MAIN AND AIR-N-VAC SHALL BE BRASS AND ALL FITTINGS ON THE AIR-N-VAC DISCHARGE SHALL BE GALVANIZED.
 - D. CONCRETE METER BOX PENETRATIONS SHALL BE GROUTED.
 - E. AIR-N-VAC RISER SHALL BE PAINTED AS DIRECTED BY THE WATER COMPANY..

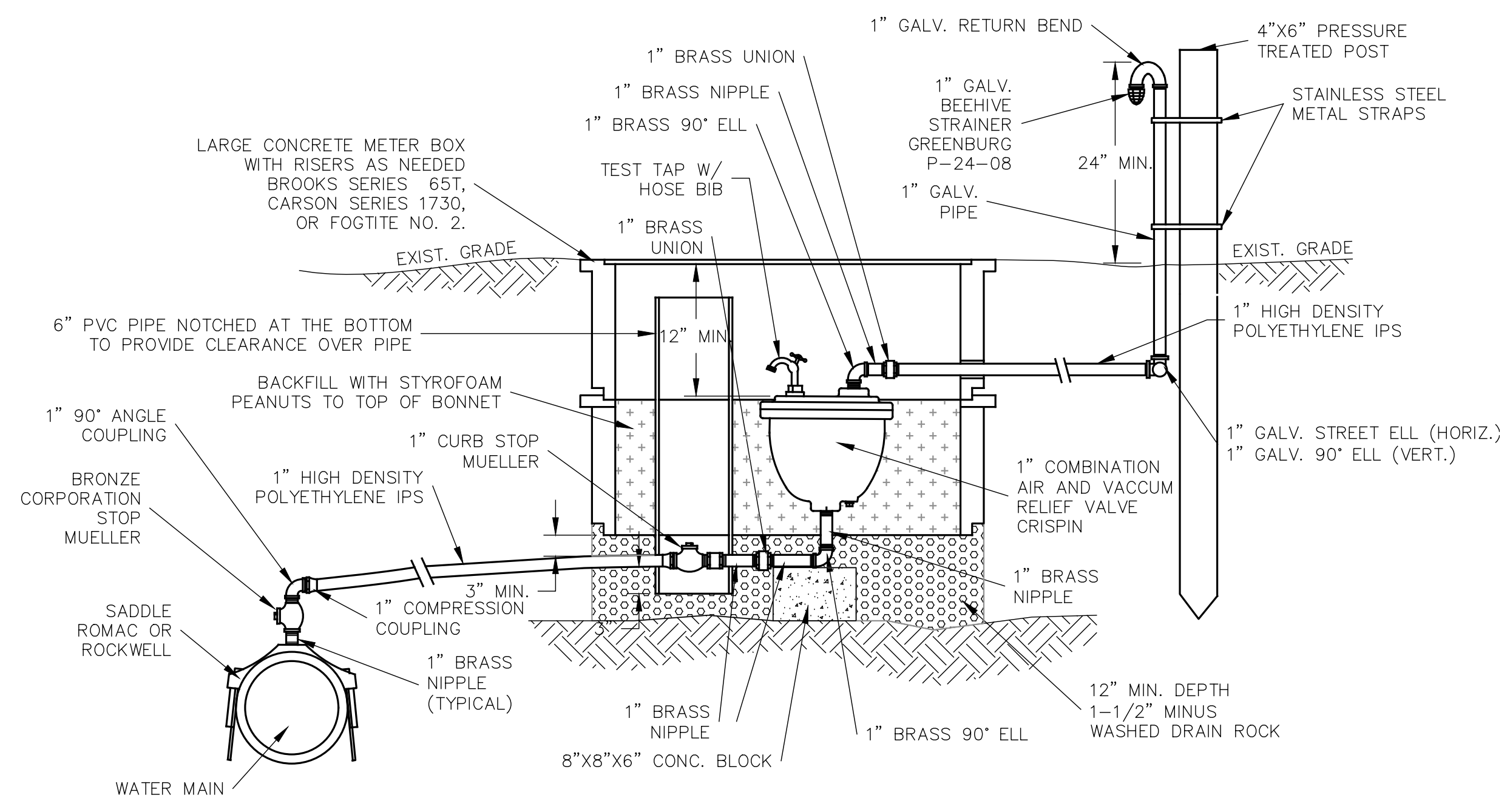

| | |
|---|--|
| | |
| 2210 Riverside Drive Suite 210 Mukwonago, WI 53075 P: 360.889.1110 F: 360.331.5131 www.dcgengr.com | |
| CALL 811 2 BUSINESS DAYS BEFORE YOU DIG <small>(UNDERGROUND UTILITY LOCATIONS ARE APPROX.)</small> | |
| | |
| <small>BASE MAP TOPOGRAPHY PROVIDED BY OTHERS. DCG CANNOT BE HELD LIABLE FOR ACCURACY. CONTRACTOR SHALL FIELD VERIFY GRADES, UTILITIES, & ALL OTHER EX FEATURES & CONDITIONS. IF CONDITIONS ARE NOT AS SHOWN, AS-BUILT PLANS CANNOT BE CONSTRUCTED AS SHOWN. CONTACT DCG PRIOR TO CONSTRUCTION.</small> | |
| OWNER: NICK FRANULOVICH 1028 278TH ST NE ARLINGTON, WA 98223 | PROJECT: TATOOSH WATER COMPANY VIEWMONT ESTATES - DEVELOPER EXTENSION DETAILS |
| PROJ. MANAGER: JT DESIGNED BY: RLC DRAWN BY: JS CHECKED BY: JT | SCALE: AS SHOWN DATE: 4/13/2020 REV: A SHEET 6 OF 6 |
| SHEET NUMBER <h1>C06</h1> | |