

**BEFORE THE
WASHINGTON UTILITIES AND TRANSPORTATION COMMISSION**

QWEST CORPORATION,

Complainant,

v.

MCLEODUSA TELECOMMUNICATIONS
SERVICES, INC., d/b/a PAETEC BUSINESS
SERVICES.

Respondent.

Docket No. UT-090892

**DECLARATION
OF
AUGUST H. ANKUM, PH.D.**

**On Behalf of
McLeodUSA Telecommunications Service, Inc.,
d/b/a PAETEC Business Services**

October 16, 2009

TABLE OF CONTENTS

I. INTRODUCTION1
A. Qualification of witness 1
B. Purpose and Summary of Conclusions 2

II. MCLEODUSA’S WSO CHARGES ARE CONSISTENT WITH ECONOMIC PRINCIPLES AND SOUND PUBLIC POLICY.....4

III. QWEST SUBMITS SERVICE REQUESTS AND CAUSES MCLEODUSA TO INCUR COSTS.....6
A. Qwest Issues Detailed LSRs that Need To Be Processed by McLeodUSA’s Service Order and Provisioning Departments..... 6
B. McLeodUSA Incurs Cost It Would Not Incur but for Qwest’s LSRs – i.e., Qwest Is the Cost Causer 10

IV. MCLEODUSA’S WSO CHARGES ARE JUST AND REASONABLE10
A. McLeodUSA Is a CLEC and Not Generally Required to Provide Cost Support for Its Prices..... 10
B. McLeodUSA Has Sought to Set Its WSO Charges at Levels Commensurate with Qwest’s for Comparable Activities..... 11
 1. *OSS Charges: Like Qwest, McLeodUSA Incurs OSS Expenses for LSRs..... 11*
 2. *Customer Transfer Charges: Like Qwest, McLeodUSA Incurs Costs for Processing Service Orders and Transferring Customers..... 12*
 3. *Loop NRCs: Like Qwest, McLeodUSA Incurs Costs for Removing a Telephone Number from Its Switch..... 15*
 4. *Qwest Commingles Costs for LSRs with Costs for Other Activities 18*
C. McLeodUSA’s WSO Charges Are on Par with Qwest’s..... 19

V. MCLEODUSA’S PRACTICES ARE NOT DISCRIMINATORY19

VI. CONCLUSION21

LIST OF EXHIBITS

Exhibit_ AA-1: Curriculum Vitae of Dr. August H. Ankum

I. INTRODUCTION

A. QUALIFICATION OF WITNESS

1. My name is Dr. August H. Ankum. I am a Senior Vice President at QSI Consulting, Inc., (“QSI”), a consulting firm specializing in economics, econometric analysis, and telecommunications cost modeling. My business address is 1027 Arch, Suite 304, Philadelphia, PA 19107.
2. QSI Consulting is a consulting firm specializing in economics and telecommunications issues and has provided services to a wide spectrum of clients such as AT&T, smaller competitive local exchange carriers (“CLECs”), governmental entities, including state public utility commissions, wireless carriers, and others.
3. I received a Ph.D. in Economics from the University of Texas at Austin in 1992, an M.A. in Economics from the University of Texas at Austin in 1987, and a B.A. in Economics from Quincy College, Illinois, in 1982.
4. My professional background covers work experiences in private industry and at state regulatory agencies. As a consultant, I have worked with large companies, such as AT&T, AT&T Wireless and MCI WorldCom (now Verizon), as well as with smaller carriers, including a variety of CLECs, wireless carriers and cable companies. I have worked on many of the arbitration proceedings between new entrants and incumbent local exchange carriers (“ILECs”). Specifically, I have been involved in arbitrations between new entrants and NYNEX (now Verizon), Bell Atlantic (now Verizon), U S WEST (now Qwest),

BellSouth (now AT&T), Ameritech (now AT&T), SBC (now AT&T), GTE (now Verizon) and Puerto Rico Telephone (now AT&T). Prior to practicing as a telecommunications consultant, I worked for MCI (now Verizon) as a senior economist. At MCI, I provided expert witness testimony and conducted economic analyses for internal purposes. Before I joined MCI in early 1995, I worked for Teleport Communications Group, Inc. ("TCG") (now AT&T), as a Manager in the Regulatory and External Affairs Division. In this capacity, I testified on behalf of TCG in proceedings concerning local exchange competition issues, such as Ameritech's Customer First proceeding in Illinois. From 1986 until early 1994, I was employed as an economist by the Public Utility Commission of Texas ("PUCT") where I worked on a variety of electric power and telecommunications issues. During my last year at the PUCT, I held the position of chief economist. Prior to joining the PUCT, I taught undergraduate courses in economics as an Assistant Instructor at the University of Texas from 1984 to 1986.

5. Of particular importance to the current proceeding is my extensive background in and experience with ILEC cost models, specifically those related to Qwest's, AT&T's and Verizon's non-recurring charges and activities.
6. A list of proceedings in which I have filed testimony is attached hereto as Exhibit AA-1.

B. PURPOSE AND SUMMARY OF CONCLUSIONS

7. The purpose of this Declaration is to address four issues raised in the June 9, 2009, Complaint of Qwest Corporation ("Qwest") against McLeodUSA Telecommunications Services, Inc., d/b/a PAETEC Business Services ("McLeodUSA") challenging its Wholesale

Service Order Charge (“Qwest’s Complaint”). Specifically, my Declaration will establish the following:

- here is an appropriate policy justification for McLeodUSA’s Wholesale Service Order (“WSO”) charges;
 - Qwest charges McLeodUSA a fee or fees in like circumstances;
 - McLeodUSA’s WSO charges are not discriminatory; and,
 - McLeodUSA's WSOs are not unjust, unreasonable, discriminatory, or anti-competitive.
8. As will be discussed, McLeodUSA is a CLEC and is not generally required to provide cost support for its service rates. As such, I will not present a detailed cost study for McLeodUSA’s WSO charges. However, in order to demonstrate that McLeodUSA’s charges are not unjust or unreasonable, I will compare McLeodUSA’s WSO charges to Qwest’s non-recurring charges (“NRCs”) to show that Qwest assesses McLeodUSA comparable charges in like circumstances. Specifically, I will analyze and discuss such charges as Qwest’s Customer Transfer Charges (“CTC”), Operational System Support (“OSS”) charges, and other unbundled loop NRCs.
9. Comparisons between McLeodUSA’s and Qwest’s charges, however, do not allow for a one-to-one mapping of Qwest’s costs to McLeodUSA’s costs for a number of reasons. First, while I will identify activities that are comparable in like circumstances, McLeodUSA and Qwest are two inherently different companies with different organizations. Next, as I will discuss in more detail below, Qwest has the practice of

commingling the costs of provisioning unbundled network elements (“UNEs”) with the costs of responding to local service requests (“LSRs”). Thus, while McLeodUSA’s WSO charges are presented on a standalone basis (*i.e.*, not commingled with costs for other services), Qwest’s NRCs commingle costs for a variety of activities. Nonetheless, by deconstructing Qwest’s NRCs into their constituent components, it can be demonstrated that McLeodUSA’s WSO charges are comparable to Qwest’s charges and costs for activities performed in like circumstances. Thus, recognizing that McLeodUSA may not have the scale and scope efficiencies of Qwest, McLeodUSA’s WSO charges should be viewed as reasonably conservative and are unlikely to overcharge for LSR-induced activities.

10. Last, to the extent Qwest believes McLeodUSA’s WSO charges are too high, Qwest could avoid such charges by agreeing to a bill-and-keep arrangement with McLeodUSA for LSR related activities, which is how McLeodUSA and other CLECs have arranged to transfer customers.

II. MCLEODUSA’S WSO CHARGES ARE CONSISTENT WITH ECONOMIC PRINCIPLES AND SOUND PUBLIC POLICY

11. In the telecommunications industry, as in other industries, when companies provide wholesale services for one another, compensation is due. This principle is rudimentary and underlies the free exchange of goods and services in the United States economy.
12. Likewise, when Qwest submits an LSR to McLeodUSA, compensation is due. McLeodUSA has established WSO charges that apply when: (a) a LEC submits LSRs to

McLeodUSA, and (b) that LEC charges McLeodUSA for performing comparable work in like circumstances.¹

13. McLeodUSA is a CLEC and as such McLeodUSA is not generally required to file cost support for its rates. Be that as it may, the Commission should recognize that McLeodUSA incurs costs in rendering services to another LEC and is entitled to adequate compensation from that LEC.
14. Conversely, to deny a company, such as McLeodUSA, the ability to be compensated for services rendered to another company, such as Qwest, would be unjust, unreasonable and bad public policy. Costs are incurred by McLeodUSA in providing these services, and to forbid recovery of those costs from the cost causer is confiscatory.
15. First, as noted, denial of cost recovery is at odds with standard practices in the telecommunications and other industries: when services are rendered, compensation is due. Further, to deny McLeodUSA compensation to recoup the costs involved in providing specific services would undermine the company's ability to render services and compete viably with other companies, such as Qwest. This, in turn, would impair the proper functioning of telecommunications markets, which is detrimental to consumers and, ultimately, the economy as a whole.

¹ See McLeodUSA Washington UTC Price List No. 1, Original Sheet No. 127, Section 7.1 Wholesale Service Order Processing.

16. In sum, as long as McLeodUSA's WSO charges are comparable to Qwest's charges in like circumstances, those charges are just and reasonable and consistent with the promotion of local exchange competition.

III. QWEST SUBMITS SERVICE REQUESTS AND CAUSES MCLEODUSA TO INCUR COSTS

A. QWEST ISSUES DETAILED LSRs THAT NEED TO BE PROCESSED BY MCLEODUSA'S SERVICE ORDER AND PROVISIONING DEPARTMENTS

17. When Qwest wins back customers from McLeodUSA, Qwest submits LSRs to McLeodUSA. These LSRs are requests for McLeodUSA to perform a number of activities that will permit Qwest to migrate customers to its network and offer those customers services off the Qwest switch (as opposed to the McLeodUSA switch). Many of the subsequent activities and services rendered by McLeodUSA have to do with McLeodUSA notifying the rest of the world (other carriers, 911, etc.) on behalf of Qwest that a customer will henceforth be served by Qwest and to facilitate the migration of the customer across the public switched network.
18. The diagram below illustrates in simple fashion a situation in which an end user customer migrates from McLeodUSA to Qwest and Qwest issues a LSR to McLeodUSA:

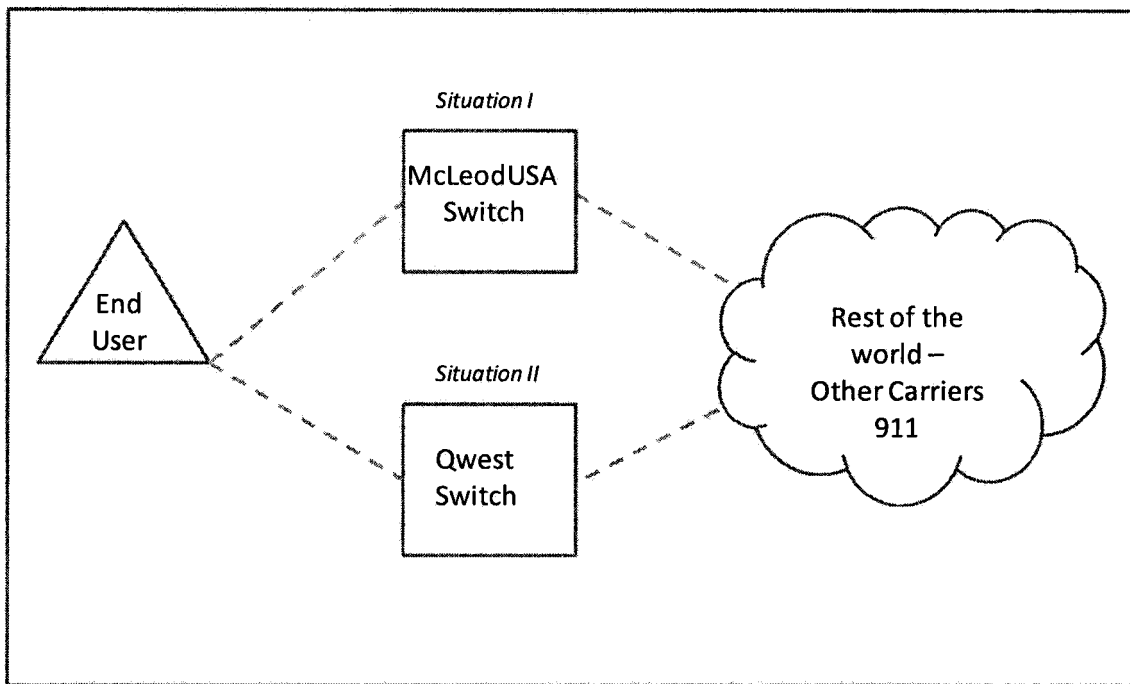

19.

20. Qwest's LSR is typically submitted electronically to McLeodUSA by populating a McLeodUSA created and maintained website, which by means of an XML² feed from the website creates an order in McLeodUSA's provisioning system. These service orders are received and reviewed by McLeodUSA personnel in McLeodUSA's Service Delivery Department, which is located in Hiawatha, Iowa, and channeled to the various departments for provisioning.

21. As noted, the general objective of Qwest's LSRs is to request that McLeodUSA notify the rest of the world that the customer is henceforth being served by Qwest and to facilitate the migration of the customer in the public switched network. More specifically, however, the

² XML stands for Extensible Markup Language. In general, XML Web-based services are designed to allow for distributed computing on the Internet, facilitating an environment where XML Web services are a platform for application integration.

LSR may trigger, depending on the nature of Qwest's request, such activities as the following:

- Release of Triggers in the McLeodUSA switch
- Grant concurrence in the NPAC
- Pull the Telephone Number from the PAETEC switch once the line has ported out
- Change McLeodUSA's internal facility assignment to the correct status
- Delete LIDB (outgoing caller ID) record
- Unlock the 911 record
- Send Care records³

22. The specifics and the timing of the activities, however, depend on the nature of Qwest's request and may vary greatly. The list below presents but a few of the large number of variables McLeodUSA Service Delivery department needs to process in order to accurately carry out the specifics of Qwest's service request:

³ These activities are discussed in more detail in Section II of the Declaration of Patricia Lynott.

23. The CCNA is an assigned value to each communications company. It identifies which company is requesting the CSR or submitting the LSR.
 CCNA, Customer Carrier Name Abbreviation, Required Field, Identifies the COMMON LANGUAGE IAC code for the customer submitting the LSR form and receiving the Local Response (LR) Form. Example: SGY.
- PON, Purchase Order Number, Required Field, Identifies the carrier's unique purchase order number that authorizes the issuance of this request or supplement. The PON is from 1 to 16 characters. The PON cannot be a duplicate of a previously submitted PON or could not have been previously cancelled. The PON is alphanumeric. Example: A1234567.
 The version is numeric and 2 characters in length. Every time a version is opened on a previously submitted PON, the version counter increase by 1.
- VER, Version Identification, Required field, Identifies the customer's PON version. The version is assigned by McLeodUSA and cannot be overwritten. Example: 01, 02, etc.
- ATN, Account Telephone Number, Required field, Identifies the account telephone number assigned by the NSP. The hyphens are required in the format. Example: 708-555-1212.
 D/TSENT, Date and Time Sent, Required Field, Date the order is being sent. MCLD will enter the value when the LSR is submitted. Example: 20030224 1405.
- DDD, Desired Due Date, Required field, Identifies the customer's due date. Has the format of YYYYMMDD, where Y = Year, M = Month, and D = Day. Cannot exceed 30 days out from the date of submission or the date of the previous FOC. The date cannot fall on a MCLD holiday or weekend. Example: 20040303.
- DFDT, Desired Frame Due Date, Optional field, Identifies desired cut over time. Depending if the end user requires a particular time. The format is HHMM in military time. The time must be between 0800 and 1700. Example: 1425.
- REQTYP, Requisition Type and Status, Required field, Identifies the type of services being requested. You must select one of the valid values from the drop down box to identify the type of services being requested. The values are AB = Loop Only, BB = Loop w/ Number Portability, and CB = Number Portability Only. Example: AB.
- ACT, Activity, Required field, Identifies the action to be taken. There is only one value, "V", conversion, which will be auto-populated. This field cannot be over-written. Example: V.
 The field identifies the manner of supplement action to be addressed by a previously submitted LSR. There is a drop down box with 3 valid values. There is no valid value drop down box default.
- SUP, Supplement Type, Conditional field, A supplement is any new iteration of an LSR. The entry in the SUP field identifies the reason for which the supplement is being issued. Values are 1 = CANCEL, 2 = DUE DATE CHANGE, 3 = OTHER. Example: 2.
- RTR, Response Type Request, Required field, Identifies the type of local response requested by the customer. Choice of C = Confirmation or N = No response required. The default value is C = Confirmation. Example: C.
- CC, Company Code, Required field, Identifies the exchange carrier requesting service. The number is nationally assigned. Enter a 4 character alphanumeric code. Example: 1234.
- NNSP, New network service provider number helps to identify the new provider of services for the end customer.
 NNSP, New Network Service Provider Identification, Required field, Identifies the Number Portability Administration Center (NPAC) Service Provider Identifier (SPI) of the new Network Service Provider. It is a 4-character code that helps identify the provider. Example: 7767.
- AGAUTH, Agency Authorization Status, Required field, Indicates that the customer is acting as an end-user's agent and has authorization on file. Valid values Y = YES or N = NO. Example: Y.
 DATED, Date of Agency Authorization, Required field, Identifies the date appearing on the agency authorization. The format is YYYYMMDD, where Y = Year, M = Month, and D = Day. Example: 20040510.

24. As noted, the above are but a subset of the variables that Qwest will use to populate the LSRs Qwest relays to the McLeodUSA service ordering and provisioning departments.

B. MCLEODUSA INCURS COST IT WOULD NOT INCUR BUT FOR QWEST'S LSRs – I.E., QWEST IS THE COST CAUSER

25. One of the key principles guiding regulators in identifying costs and setting rates is the *cost causation principle* and the notion that the cost-causer should pay. This same principle should be applied in the current proceeding.
26. McLeodUSA would not engage in the aforementioned activities – nor would it incur the associated costs (to be discussed below) – but for the LSRs submitted by Qwest. This means that Qwest is the cost causer, and, thus, consistent with a standard principle of public utility regulation – the cost causation principle – Qwest should be required to compensate McLeodUSA.
27. Qwest engages in similar activities when McLeodUSA wins a customer from Qwest and submits an LSR to Qwest; Qwest rightfully expects McLeodUSA to compensate Qwest via payment of NRCs, to be discussed presently, to recoup the costs of activities and systems that Qwest has in place to process LSRs submitted by McLeodUSA.

IV. MCLEODUSA'S WSO CHARGES ARE JUST AND REASONABLE

A. MCLEODUSA IS A CLEC AND NOT GENERALLY REQUIRED TO PROVIDE COST SUPPORT FOR ITS PRICES

28. As demonstrated previously, McLeodUSA incurs costs in rendering services to Qwest, and the WSO charges are intended to compensate McLeodUSA for those costs.
29. As a *competitive* local exchange carrier, however, McLeodUSA is not generally required to perform detailed cost studies to support its prices. Instead, McLeodUSA has sought to set

prices for services to competitors commensurate with prices assessed by Qwest in comparable circumstances. Qwest's prices should be cost-based and would have been approved by the applicable state utility agency.

30. Such voluntary benchmarking of rates is not unreasonable and appears consistent with the Telecommunications Act of 1996 ("Act"). For example, with respect to reciprocal compensation, the Federal Communications Commission ("FCC") interpreted certain provisions of the Act as permitting CLECs to mirror the ILECs' costs and rates in lieu of performing their own costs studies, though clearly the CLECs should have the option to provide its own cost studies in the event there are reasons that the CLECs' costs are higher than the ILECs'.⁴

B. McLEODUSA HAS SOUGHT TO SET ITS WSO CHARGES AT LEVELS COMMENSURATE WITH QWEST'S FOR COMPARABLE ACTIVITIES

31. McLeodUSA's WSO charges are intended to reflect comparable charges assessed on McLeodUSA by Qwest. At a minimum, McLeodUSA should be permitted to assess Qwest charges on par with a combination of Qwest's OSS charges and comparable portions of Qwest's customer transfer ("CTC") and Qwest's UNE loop NRC charges.

1. OSS Charges: Like Qwest, McLeodUSA Incurs OSS Expenses for LSRs

32. When McLeodUSA submits LSRs to Qwest, Qwest assesses McLeodUSA \$7.03 in Operational Support Systems ("OSS") charges ($\$3.27 + \$3.76 = \$7.03$):

⁴ See, e.g., 47 C.F.R. § 51.711(a) and (b).

- | 12.0 Operational Support Systems | | Non-Recurring
Charges |
|----------------------------------|---|--------------------------|
| 12.1 | Development and Enhancements, per LSR Request | \$3.27 |
| 12.2 | Ongoing Maintenance, per LSR Request | \$3.76 |
- 33.
34. Like Qwest, McLeodUSA constructed OSS to permit Qwest and other carriers to submit LSRs to McLeodUSA, and like Qwest, McLeodUSA incurred and continues to incur OSS expenses.⁵
35. While Qwest's *total* OSS expenses are likely larger than McLeodUSA's, Qwest also processes larger volumes of LSRs than McLeodUSA and therefore is able to spread its costs over larger volumes of LSRs. To the extent that Qwest enjoys economies of scale in its OSS (not enjoyed by McLeodUSA), Qwest's OSS charges are a conservative proxy for McLeodUSA's costs and set a minimal level for McLeodUSA's WSOs.

2. Customer Transfer Charges: Like Qwest, McLeodUSA Incurs Costs for Processing Service Orders and Transferring Customers

36. As discussed previously, McLeodUSA engages in a host of activities to transfer a customer to Qwest. Like Qwest, McLeodUSA incurs costs for such activities. To see what costs may be involved, it is instructive to examine Qwest's customer transfer charge cost support, offered by Qwest.
37. Qwest's customer transfer charges apply when a Qwest customer transfers to a CLEC under a resale arrangement. Examination of Qwest's customer transfer charges is

⁵ McLeodUSA's OSS were discussed previously. Also, see the discussion of McLeodUSA's OSS in the Declaration of Patricia Lynott on behalf of McLeodUSA.

informative in that it reveals Qwest's activities and expenses for updating its systems to reflect that a customer has been transferred to another carrier.

38. Further, because it concerns a resale situation, Qwest's technicians do not perform any physical work to rearrange network facilities. Thus, as the cost support below demonstrates, the cost entries identified by Qwest reflect merely the review of service orders and entering data into systems to reflect that the customer has transferred to another carrier, a situation very similar to the one experienced by McLeodUSA when it receives a request from Qwest for a customer transfer.
39. Recognizing that McLeodUSA's systems are not identical to Qwest's (the systems are not off-the-shelf but custom build), no one-to-one mapping of activities is possible, but generally McLeodUSA personnel need to perform many of the same functional activities to transfer a customer upon Qwest's request.
40. Qwest identifies the following activities and costs for transferring a customer:

NONRECURRING COST DETAIL SUMMARY (PRESCRIBED)							Qwest. Advice No. 3364T Page 175 Of 194		
Study Name: GENERIC DOCKET NRC ELEMENTS FOR PART B COMPLIANCE - 38TH SUPP ORDER									
Study Year: 1996									
Analyst: Deffley									
ProductGroup: Interconnection									
State: Washington									
Work Item	Time Minutes	Prob #1	Prob #2	Prob #3	Prob #4	Applied Time (Minutes)	Labor /Hour	Cost	
A	B	C	D	E	F	G	H	I	
						B * (C Thru F)		H * (G/60)	
CUSTOMER TRANSFER CHARGE POTS, FIRST MANUAL									
'ADD'									
INTERCONNECT SERVICE CENTER									
Receive request and send CSR (Customer Service	3	1,000				3.00	\$33.24	\$1.66	
Receive and screen LSR (Loop Service Request)	5	1,000				5.00	\$33.24	\$2.77	
Type change of Service Provider - 1st line	10	1,000				10.00	\$33.24	\$5.54	
SYSTEMS COSTS FOR RESALE								\$3.76	
Subtotal - INTERCONNECT SERVICE CENTER						18.00		\$13.73	

41.

42. Again, the activities identified by Qwest pertain to review of the LSR and entering it into Qwest's OSS. McLeodUSA performs comparable activities when Qwest submits LSRs.
43. Further, Qwest notes that these activities (for which Qwest identifies a cost of \$13.73) require administrative, sales, and product management support; in view of this, Qwest adds further "attributable direct" costs and other business fees to arrive at a TELRIC cost of \$19.28 (see below). Likewise, McLeodUSA incurs "attributable" costs for comparable support activities.

NONRECURRING COST DETAIL SUMMARY (PRESCRIBED)

Qwest, Advice No. 3364T
Page 176 Of 194

Study Name: GENERIC DOCKET NRC ELEMENTS FOR PART B COMPLIANCE - 38TH SUPP ORDER
 Study Year: 1996
 Analyst: Deffley
 ProductGroup: Interconnection
 State: Washington

Work Item	Time Minutes	Prob #1	Prob #2	Prob #3	Prob #4	Applied Time (Minutes)	Labor /Hour	Cost
A	B	C	D	E	F	G	H	I
						B * (C Thru F)		H * (G/60)
			Direct	Direct Attributed				
Administrative (0.1129):			N/A	\$1.55				
Attributed Cost (0.1962):			N/A	\$2.69				
Inward & Outward With Attributable:			13.730	4.240				
Interconnection								
Sales Expense (0.0141):			\$0.22	N/A				
Product Management (0.0109):			\$0.17	N/A				
Business Fees (0.0500):			\$0.71	\$0.21				
Product Based Subtotal:			\$1.10	\$0.21				
			Total Direct Costs:	\$14.83				
			Total Element Long Run Incremental C	\$19.28				

44.

45. Then, after adding additional shared and common costs, Qwest identifies a total costs for transferring a customer of \$21.24.⁶ Of course, like Qwest, McLeodUSA needs to recover its shared and common costs associated with LSR-induced activities and costs.
46. It is important to note that Qwest assesses the customer transfer charge when the customer moves to a CLEC *and again* when the customer moves to Qwest. That is, Qwest demands to be fully compensated for any and all of the administrative tasks associated with transferring customers whether they leave *or* come to Qwest.
47. While McLeodUSA's costs may not be identical to Qwest's – and they may possibly be higher – clearly, McLeodUSA must engage in many of the same or at least comparable activities to transfer customers to Qwest.

3. Loop NRCs: Like Qwest, McLeodUSA Incurs Costs for Removing a Telephone Number from Its Switch

48. As discussed, to transfer a customer to Qwest, McLeodUSA needs to release the customer's telephone number from the McLeodUSA switch in which it resides, in part so that the rest of the world knows that Qwest is now the serving carrier, 911 calls can be routed correctly, etc. These activities are comparable to Qwest's for which Qwest expects to be compensated.
49. To see that this is true, consider the descriptions of Qwest's service ordering processes and costs for UNE loop NRCs, found in Qwest's Minnesota Documentation Book, December

⁶ Under TELRIC pricing, \$21.24 is also Qwest's Commission approved TELRIC price for customer transfers.

2006.⁷ These descriptions are to my knowledge still the most current and detailed descriptions of Qwest's service ordering and provisioning processes to have been made available in cost proceedings.

50. The following discussion pertains to Qwest's costs associated with transferring customers between Qwest and CLECs as part of installing and disconnecting *unbundled loops*. As will be discussed presently, even when a CLEC orders an unbundled loop – *i.e.*, the CLEC does not order any switch related services from Qwest – Qwest identifies and recoups from CLECs costs for *switch related activities*. This is true even for UNE loop disconnect orders that involve disconnecting the UNE loop from the CLEC's switch and not from Qwest's switch.
51. Specifically, Qwest's cost documentation discusses the activities associated with the "physical switch" and the customer's telephone number. (See below.) Again, the discussion here concerns a transfer of customers served by means of UNE loops. The Qwest Documentation Book provides the following discussion:

⁷ See Qwest's Response to PAETEC 1st Set of Data requests to Qwest, no.6, Attachment B. Qwest filed the Documentation Book in support of its Non-Recurring Costs in Minnesota Docket No. P421/AM-06-713. This documentation is relevant to the current docket since Qwest's service ordering and provisioning practices are shared across all of its serving areas.

NONRECURRING COST STUDY SUPPORT DOCUMENTATION

PRODUCT: Unbundled Loop, Subloop, Enhanced Extended Loop, Loop-Mux
 WORK CENTER: LOOP PROVISIONING CENTER
 DATE: JULY 21, 2004
 SOURCE: GARY STACY
 TITLE: LEAD PROCESS ANALYST
 PHONE: 303-707-3277

ASSUMPTIONS: The average clearing time shown is an objective. Average clearing time per RMA includes all order types: inward, outwa and changes as well as single and multi-line requests. Specific objectives have not been established for inward:change or outward activity.

INSTALL				
WORK ITEM	WORK ACTIVITY DESCRIPTION / DETAIL (Define Acronyms)	TIME ESTIMATE (MINUTES)	PROBABILITY OF MANUAL OCCURRENCE POTENTIAL (%)	PROBABILITY OF MANUAL OCCURRENCE DESIGNER (%)
1	Clear RMA (Request for Manual Assistance)	11.25	15	40
DISCONNECT				
WORK ITEM	WORK ACTIVITY DESCRIPTION / DETAIL (Define Acronyms)	TIME ESTIMATE (MINUTES)	PROBABILITY OF OCCURRENCE POTENTIAL (%)	PROBABILITY OF OCCURRENCE DESIGNER (%)
1	Clear RMA (Request for Manual Assistance)	11.25	15	40

52.

PROCESS DETAILS

The LPC is responsible for ensuring customer service order activity is provisioned with outside plant and central office facilities in a timely and accurate manner. The Facility Assignment Control System (FACS) which is comprised of components; Service Order Analysis and Control (SOAC), Position Analysis Workstation (PAWS), Loop Facilities Assignment and Control (LFACS) and SWITCH is the provisioning application supported by the LPC. Assignment Consultants are the employees responsible for FACS component exception messages.

Brief descriptions of the FACS components are:

SOEC - maintains control and status information on all service order requests, as well as the input image and certain data resulting from processing. This system interfaces with the service order processor (SOP) and the other service provisioning systems. SOAC generates assignment requests to LFACS for outside plant and to SWITCH for central office facilities. After assignments are made, SOAC receives responses from LFACS and SWITCH, merges and formats this data into a service order assignment section and automatically returns it to the SOP. SOAC sends the formatted assignments to Work Force Administration/Dispatch Out (WFA/DO). For switched customer service requests SOAC sends the telephone number, office equipment and features to MARCH for translation to the physical switch.⁸

53.

54. It should further be noted that there is truly very little, if any, outside plant or network related activities that Qwest technicians need to perform when a customer transfers from a CLEC to Qwest.⁹ The point is that nearly all of Qwest's costs are associated with updating

⁸ *Id.* at 96 Of 449 (emphasis added).

⁹ Qwest maintains a high percentage of Dedicated Inside Plant ("DIP"), obviating the need for much if any actual physical rearrangement of the network. In fact, the FCC, in its Virginia Arbitration Order found that all

databases in its OSS and switches. Of course, *these are very much the same activities that McLeodUSA performs and costs McLeodUSA incurs for transferring a customer to Qwest.*¹⁰

55. Given that it concerns comparable circumstances, it is important that McLeodUSA, like Qwest, be allowed to recoup these costs from the cost causer.

4. *Qwest Commingles Costs for LSRs with Costs for Other Activities*

56. Qwest claims that it does not apply LSR charges. This is not true. As illustrated above, Qwest commingles the costs of UNE/ resale provisioning with the costs for processing LSRs. Given that CLECs generally order wholesale products from Qwest at the same time they order wholesale products from Qwest, this practice is not necessarily objectionable. However, it does obscure the fact that Qwest too applies wholesale service order charges.
57. Further underscoring the fact that ILECs apply service order charges is that unlike Qwest, AT&T when operating as an ILEC does explicitly separate its NRCs into *service order* charges and *service provisioning* charges. That is, while Qwest's NRCs commingle various activities into a single NRC, which activities include the lift and lay activities, AT&T has separate NRCs for order processing and provisioning.

inside plant facilities are dedicated and in place (i.e., 100% DIP). See Virginia Arbitration Order, CC Docket No. 00-218, ¶¶ 587, 588.

¹⁰ As an ancillary observation, it is quite troubling that Qwest generally seeks to recover switch related costs from CLECs when CLECs order unbundled loops. This is particularly so where it concerns a loop disconnect, when the unbundled loop (circuit) terminates in the CLEC switch and never even touches the Qwest switch. This docket, however, is not the place to pursue this issue, and the observation serves only to underscore the fact that Qwest seeks to have CLECs pay for transferring customers regardless of whether the customer prefers the CLEC or Qwest, as if the "customer" were Qwest's to be leased out in the same manner that Qwest leases its loops.

58. In sum, the observation that Qwest does not apply explicit standalone WSO LSR charges in no way demonstrates that Qwest does not apply charges for LSRs: it does – commingled with charges for other wholesale services.

C. MCLEODUSA’S WSO CHARGES ARE ON PAR WITH QWEST’S

59. In the previous sections I have demonstrated that McLeodUSA is only seeking to recover costs from Qwest for activities for which Qwest charges McLeodUSA in comparable circumstances. Again, while McLeodUSA, as a CLEC, is not generally required to provide cost support for its rates, a comparison with Qwest’s rates, such as Qwest’s Customer Transfer Charge (\$21.24), OSS charges (\$7.03), and UNE Loop related NRCs (at various levels) demonstrates that McLeodUSA’s WSO charges to Qwest are just and reasonable in the sense that they are appropriately assessed and do not overcharge Qwest. This is particularly true since one would expect that Qwest – due to greater economies of scale and scope – is able to run more efficient operations for such activities than McLeodUSA, which suggests that McLeodUSA’s WSO charges are possibly set too low to recoup all of its costs, thus favoring Qwest.¹¹

V. MCLEODUSA’S PRACTICES ARE NOT DISCRIMINATORY

60. While McLeodUSA does not assess explicit WSO charges on other CLECs, this practice is by no means discriminatory for the following reasons.
61. First, other CLECs do not charge McLeodUSA WSOs either, as part of an implicit or explicit agreement to bill and keep. As recognized by the FCC and others, bill and keep is

¹¹ The FCC has consistently recognized that the RBOCs enjoy economies of scale and scope not enjoyed by CLECs. For example, CC Docket 96-98, *First Report and Order*, ¶ 232.

a form of barter that provides for in-kind compensation (much like, say, a baker may agree with a butcher to exchange bread for meatloaf.) The following language, while addressing reciprocal compensation for the exchange of local traffic, explains the concept of bill and keep as a form of compensation:

That subsection further provides that the foregoing language shall not be construed "to preclude arrangements that afford the mutual recovery of costs through the offsetting of reciprocal obligations, including arrangements that waive mutual recovery (such as bill and keep arrangements)," or to authorize the Commission or any state to "engage in any rate regulation proceeding to establish with particularity the additional costs of transporting or terminating calls, or require carriers to maintain records with respect to the additional costs of such calls." The legislative history indicates that "mutual and reciprocal recovery of costs . . . may include a range of compensation schemes, such as in-kind exchange of traffic without cash payment (known as bill-and-keep arrangements).¹²

62. That is, an "in kind" compensation arrangement between McLeodUSA and other CLECs provides for compensation even if it does not involve "cash payments." In fact, McLeodUSA and Qwest use "bill and keep" for handling compensation for the exchange of local traffic throughout the Qwest region.
63. Second, McLeodUSA is willing to extend the "in kind" arrangements with other CLECs – under which carriers mutually absorb certain wholesale costs as a cost of doing business – to Qwest *provided that it is mutual*.
64. However, McLeodUSA is not willing and should not be required to unilaterally waive compensation for costs it incurs while Qwest imposes charges for comparable activities on McLeodUSA – such an arrangement, by contrast, *would be* discriminatory, as it gives Qwest a free ride at the expense of McLeodUSA.

¹² *Id.*, ¶ 1027 (emphasis added).

VI. CONCLUSION

65. I have demonstrated that McLeodUSA's WSO charges reflect fees that Qwest assesses McLeodUSA under comparable circumstances. I have also demonstrated that McLeodUSA's WSO charges are just, reasonable, and non-discriminatory and consistent with the promotion of a level competitive playing field for local exchange services.
66. I declare under penalty of perjury that the foregoing is true and correct.



August H. Ankum, Ph.D.

Executed this 18 day of October, 2009