

Issued: November 20, 2013
Effective: December 21, 2013
Attachment "A" to Schedule 80, Page 1

PUGET SOUND ENERGY

Attachment "A" Application Tier 1

**SCHEDULE 80
APPLICATION FOR INTERCONNECTING AN INVERTED-BASED GENERATING FACILITY
ELIGIBLE UNDER TIER 1**

This application is considered complete when it provides all applicable and correct information required below. Additional information to evaluate the Application may be required. Certain terms in this application are defined in Schedule 80.

Application Fee

A non-refundable application fee of \$100 must accompany this Application.

Interconnection Customer

Name: _____

Contact name if Interconnection Customer is a business: _____

Address: _____

City: _____ State: _____ Zip: _____

Telephone (Day): _____

(Evening): _____

Fax: _____ E-Mail Address: _____

Contact or Consultant (if different from Interconnection Customer)

Name: _____

Address: _____

City: _____ State: _____ Zip: _____

Telephone (Day): _____ (Evening): _____

Fax: _____ E-Mail Address: _____

Owner(s) of the facility (include % ownership by any electric utility): _____

Generating Facility Information

Location (if different from above): _____

City: _____ State: _____ Zip: _____

PSE Account Number: _____

Inverter Manufacturer: _____ Model: _____

Nameplate Rating: _____ (kW) _____ (kVA) _____ (AC Volt)

Issued: November 20, 2013
Effective: December 21, 2013
Attachment "A" to Schedule 80, Page 2

WN U-60

PUGET SOUND ENERGY

Attachment "A" Tier 1 Application

Single Phase _____ Three Phase _____

System Design Capacity: _____ (kW) _____ (kVA)

Prime Mover: Photovoltaic ___ Reciprocating Engine ___ Fuel Cell ___ Turbine ___ Other

Energy Source: Solar ___ Wind ___ Hydro ___ Diesel ___ Natural Gas ___ Fuel Oil ___

Other (describe) _____

Is the equipment UL®1741 listed? Yes ___ No ___

If Yes, attach manufacturer's cut-sheet showing UL®1741 listing

Estimated Installation Date: _____ Estimated In-Service Date: _____

List components of the Generating Facility equipment package that are currently certified:

Equipment Type	Certifying Entity
1. _____	_____
2. _____	_____
3. _____	_____
4. _____	_____
5. _____	_____

Interconnection Customer Signature

I hereby certify that, to the best of my knowledge, the information provided in this Application is true. I agree to abide by the General Rules And Provisions for interconnecting a Tier 1 Generating Facility and return the Certificate of Completion when the Generating Facility has been installed, but prior to actual Interconnection.

Signed: _____

Title: _____ Date: _____

Contingent Approval for Interconnection of the Generating Facility

(For Company use only)

Interconnection of the Generating Facility no larger than 25 kW is approved contingent upon compliance with the General Rules And Provisions for Interconnection With Electric Generators, including return of the Certificate of Completion and execution of an Interconnection Agreement prior to Interconnection and inspection by the Company.

PSE Representative's Signature: _____

Title: _____ Date: _____

Company waives inspection/witness test? Yes ___ No ___

Issued: November 20, 2013
Effective: December 21, 2013
WN U-60 Attachment "B" to Schedule 80, Page 1

PUGET SOUND ENERGY

Attachment "B" Application - Tier 2 and Tier 3

**SCHEDULE 80
APPLICATION FOR INTERCONNECTING A GENERATING FACILITY
TIER 2 OR TIER 3**

This application is considered complete when it provides all applicable and correct information required below. Additional information to evaluate the Application may be required. Certain terms in this application are defined in Schedule 80.

Application Fee

A non-refundable application fee must accompany this Application.

For Generating Facilities of 0 kW to 25 kW the application fee is \$100.00

For Generating Facilities of greater than 25 kW to 500 kW the application fee \$500.00

For Generating Facilities of greater than 500 kW to 20 MW the application fee is \$1000.00 For Generating Facilities of greater than 2 MW or up to 20 MW or submitted under the "Study Process" described in the "Small Generator Interconnection Procedures" ("SGIP") attached to the Company's open access transmission tariff, the application fee shall be \$1000.00. The SGIP are attached to the Company's open access transmission tariff which can be found at www.oatioasis.com/psei.

Puget Sound Energy ("PSE" or "Company"):

Designated Contact Person: _____

Address: _____

Telephone Number: _____

Fax: _____

E-Mail Address: _____

[Note: The blanks above shall be filled in prior to sending this form to an Interconnection Customer.]

This Application is considered complete when it provides all applicable and correct information required below. Additional information to evaluate the Application may be required. Certain terms in this application are defined in Schedule 80. In accordance with SGIP section 1.5, documentation of site control must be submitted with the Application.

Preamble and Instructions

An Interconnection Customer who requests Interconnection must submit this Application by hand delivery, mail, e-mail, or fax to the Company.

Interconnection Customer Information

Legal Name of the Interconnection Customer (or, if an individual, individual's name)

Name: _____

Issued: November 20, 2013
Effective: December 21, 2013

WN U-60 Attachment "B" to Schedule 80, Page 2

PUGET SOUND ENERGY

Attachment "B" Application - Tier 2 and Tier 3

Contact Person: _____

Mailing Address: _____

City: _____ State: _____ Zip: _____

Facility Location (if different from above): _____

Telephone (Day): _____ Telephone (Evening): _____

Fax: _____ E-Mail Address: _____

Alternative Contact Information (if different from the Interconnection Customer)

Contact Name: _____

Title: _____

Address: _____

Telephone (Day): _____ Telephone (Evening): _____

Fax: _____ E-Mail Address: _____

Application is for: New Generating Facility
 Capacity addition to Existing Generating Facility

If capacity addition to existing facility, please describe: _____

Will the Generating Facility be used for any of the following?

- Net Metering? Yes ___ No ___
- To Supply Power to the Interconnection Customer? Yes ___ No ___
- To Supply Power to Others? Yes ___ No ___

For installations at locations with existing electric service to which the proposed Generating Facility will interconnect, provide:

(Existing PSE Account Number*)

Requested Point of Interconnection: _____

Interconnection Customer's Requested In-Service Date: _____

Issued: November 20, 2013
Effective: December 21, 2013

WN U-60 Attachment "B" to Schedule 80, Page 3

PUGET SOUND ENERGY

Attachment "B" Application - Tier 2 and Tier 3

Generating Facility Information

Data apply only to the Generating Facility, not the Interconnection Facilities.

Energy Source: Solar Wind Hydro Hydro Type (e.g. Run-of-River): _____

Diesel Natural Gas Fuel Oil Other (state type) _____

Prime Mover: Fuel Cell Recip Engine Gas Turb Steam Turb Microturbine
 PV Other _____

Type of Generator: Synchronous Induction Inverter

Generator Nameplate Rating: _____ kW (Typical) Generator Nameplate kVAR: _____

Interconnection Customer or Customer-Site Load: _____ kW (if none, so state)

Typical Reactive Load (if known): _____

Maximum Physical Export Capability Requested: _____ kW

List components of the Generating Facility equipment package that are currently certified:

Equipment Type	Certifying Entity
1. _____	_____
2. _____	_____
3. _____	_____
4. _____	_____
5. _____	_____

Is the prime mover compatible with the certified protective relay package? Yes No

Generator (or solar collector)
Manufacturer, Model name & Number: _____
Version Number: _____

Nameplate Output Power Rating in kW: (Summer) _____ (Winter) _____
Nameplate Output Power Rating in kVA: (Summer) _____ (Winter) _____

Individual Generator Power Factor
Rated Power Factor: Leading: _____ Lagging: _____

Total Number of Generators in wind farm to be interconnected pursuant to this
Application: _____ Elevation: _____ Single phase Three phase

Inverter Manufacturer, Model Name & Number (if used):

Issued: November 20, 2013
Effective: December 21, 2013
WNU-60 Attachment "B" to Schedule 80, Page 4

PUGET SOUND ENERGY

Attachment "B" Application - Tier 2 and Tier 3

List of Adjustable set points for the protective equipment of software: _____

Note: A completed Power Systems Load Flow data sheet must be supplied with the Application.

Generating Facility Characteristic Data (for inverter-based machines)

Max design fault contribution current: _____ Instantaneous ___ or RMS? _____

Harmonics Characteristics: _____

Start-up requirements: _____

Generating Facility Characteristic Data (for rotating machines)

RPM Frequency: _____
(* Neutral Grounding Resistor (If Applicable): _____

Synchronous Generators:

Direct Axis Synchronous Reactance, X_d : _____ P.U.
Direct Axis Transient Reactance, X'_d : _____ P.U.
Direct Axis Subtransient Reactance, X''_d : _____ P.U.
Negative Sequence Reactance, X_2 : _____ P.U.
Zero Sequence Reactance, X_0 : _____ P.U.
KVA Base: _____
Field Volts: _____
Field Amperes: _____

Induction Generators

Motoring Power (kW): _____
 I_2^2t or K (Heating Time Constant): _____
Rotor Resistance, R_r : _____
Stator Resistance, R_s : _____
Stator Reactance, X_s : _____
Rotor Reactance, X_r : _____
Magnetizing Reactance, X_m : _____
Short Circuit Reactance, X_d'' : _____
Exciting Current: _____
Temperature Rise: _____
Frame Size: _____
Design Letter: _____
Reactive Power Required in Vars (No Load): _____
Reactive Power Required in Vars (Full Load): _____
Total Rotating Inertia, H: _____ Per Unit on kVA Base

Issued: November 20, 2013
Effective: December 21, 2013

WN U-60 Attachment "B" to Schedule 80, Page 5

PUGET SOUND ENERGY

Attachment "B" Application - Tier 2 and Tier 3

Note: Please contact the Company prior to submitting the Application to determine if the specified information above is required.

Excitation and Governor System Data for Synchronous Generators Only

Provide appropriate IEEE model block diagram of excitation system, governor system and power system stabilizer (PSS) in accordance with the regional reliability council criteria. A PSS may be determined to be required by applicable studies. A copy of the manufacturer's block diagram may not be substituted.

Interconnection Facilities Information

Will a transformer be used between the generator and the point of common coupling (PCC)?
 Yes No

Will the transformer be provided by the Interconnection Customer? Yes No

Transformer Data (If Applicable, for Interconnection Customer-Owned Transformer):

Is the transformer: single phase three phase? Size: _____ kVA
Transformer Impedance: _____ % on _____ kVA Base

If Three Phase:

Transformer Primary: _____ Volts Delta Wye Wye Grounded
Transformer Secondary: _____ Volts Delta Wye Wye Grounded
Transformer Tertiary: _____ Volts Delta Wye Wye Grounded

Transformer Fuse Data (If Applicable, for Interconnection Customer-Owned Fuse):

(Attach copy of fuse manufacturer's Minimum Melt and Total Clearing Time-Current Curves)

Manufacturer: _____ Type: _____ Size: _____ Speed: _____

Interconnecting Circuit Breaker (if applicable):

Manufacturer: _____ Type: _____
Load Rating (Amps): _____ Interrupting Rating (Amps): _____ Trip Speed (Cycles): _____

Interconnection Protective Relays (of applicable):

If Microprocessor-Controlled:

List of Functions and Adjustable Setpoints for the protective equipment or software:

Setpoint Function	Minimum	Maximum
-------------------	---------	---------

Issued: November 20, 2013
Effective: December 21, 2013
WN U-60 Attachment "B" to Schedule 80. Page 6

PUGET SOUND ENERGY

Attachment "B" Application - Tier 2 and Tier 3

1. _____
2. _____
3. _____
4. _____
5. _____
6. _____

If Discrete Components:

(Enclose Copy of any Proposed Time-Overcurrent Coordination Curves)

Manufacturer: _____	Type: _____	Style/Catalog No.: _____	Proposed Setting: _____
Manufacturer: _____	Type: _____	Style/Catalog No.: _____	Proposed Setting: _____
Manufacturer: _____	Type: _____	Style/Catalog No.: _____	Proposed Setting: _____
Manufacturer: _____	Type: _____	Style/Catalog No.: _____	Proposed Setting: _____
Manufacturer: _____	Type: _____	Style/Catalog No.: _____	Proposed Setting: _____

Current Transformer Data (if applicable):

(Enclose Copy of Manufacturer's Excitation and Ratio Correction Curves)

Manufacturer: _____
Type: _____ Accuracy Class: ___ Proposed Ratio Connection: ___

Manufacturer: _____
Type: _____ Accuracy Class: ___ Proposed Ratio Connection: ___

Potential Transformer Data (if applicable):

Manufacturer: _____
Type: _____ Accuracy Class: ___ Proposed Ratio Connection: ___

Manufacturer: _____
Type: _____ Accuracy Class: ___ Proposed Ratio Connection: ___

General Information

Enclose copy of site electrical one-line diagram showing the configuration of all Generating Facility equipment, current and potential circuits, and protection and control schemes. This one-line diagram must be signed and stamped by a licensed Professional Engineer if the Generating Facility is larger than 50 kW. Is One-Line Diagram Enclosed? ___ Yes ___ No

Issued: November 20, 2013
Effective: December 21, 2013

WN U-60

Attachment "B" to Schedule 80, Page 7

PUGET SOUND ENERGY

Attachment "B" Application - Tier 2 and Tier 3

Enclose copy of any site documentation that indicates the precise physical location of the proposed Generating Facility (e.g., USGS topographic map or other diagram or documentation).

Proposed location of protective interface equipment on property (include address if different from the Interconnection Customer's address) _____

Enclose copy of any site documentation that describes and details the operation of the protection and control schemes. Is Available Documentation Enclosed? ___Yes ___No

Enclose copies of schematic drawings for all protection and control circuits, relay current circuits, relay potential circuits, and alarm/monitoring circuits (if applicable).
Are Schematic Drawings Enclosed? ___Yes ___No

Applicant Signature

I hereby certify that, to the best of my knowledge, all the information provided in this Application is true and correct.

For Interconnection Customer: _____ Date: _____

Issued: November 20, 2013

Effective: December 21, 2013

WN U-60

Attachment "C-1" to Schedule 80, Page 1

PUGET SOUND ENERGY

Attachment "C-1" Procedures, Terms & Conditions- Tier 1 Generating Facilities

**SCHEDULE 80
PROCEDURES, AND TERMS AND CONDITIONS FOR INTERCONNECTING
A CERTIFIED INVERTER-BASED GENERATING FACILITY ELIGIBLE FOR TIER 1 ("TIER 1
PROCESS")**

- 1.0 The Interconnection Customer completes Attachment A to Schedule 150 or the Application in the form of Attachment A or to Schedule 80 and submits it to the Company with the applicable non-refundable application fee.
- 2.0 Upon receipt the Company stamps the application with the date and time of receipt and within five business days the Company sends notice of receipt to the Interconnection Customer.
- 3.0 The Company evaluates the Application for completeness and notifies the Interconnection Customer within ten Business Days of receipt that the Application is or is not complete and, if not, advises what material is missing.
- 3.01 The Interconnection Customer must supply the necessary information for a complete Application or request an extension of time within fifteen business days. The Company is not obligated to grant a request for extension of time. If the Interconnection Customer does not provide the necessary information or request an extension of time that is granted by the Company within fifteen business days the application expires.
- 4.0 The Company verifies that the Generating Facility can be Interconnected safely and reliably and complies with the technical standards established in WAC 480-108-020 and the Company's standards. The Company has twenty business days following approval of a complete Application to complete this process and shall approve, approve with conditions, or deny the application with written justification. For Interconnection Customers that do not complete Attachment A to Schedule 150, the notice shall include an Interconnection Agreement in the form of Attachment E to Schedule 80. If delays result from unforeseen circumstances, Interconnection Customer variance requests, or other incentive program approval requirements, the Company shall promptly notify the Interconnection Customer.
- 4.01 The Interconnection Customer must Interconnect and operate the Generating Facility within one (1) year from the date of the Company's approval of the Application, or the Application expires, unless the Company, in its sole discretion, grants an extension in writing.
- 4.02 The Interconnection Customer, who has not executed Attachment A to Schedule 150, must execute and return the Interconnection Agreement within thirty business days and prior to physical Interconnection.
- 5.0 After installation, the Interconnection Customer returns the Certificate of Completion to the Company. Prior to parallel operation, the Company may inspect the Generating Facility for compliance with standards which may include a witness test, and may schedule appropriate metering replacement, if necessary.

Issued: November 20, 2013

Effective: December 21, 2013

WN U-60

Attachment "C-1" to Schedule 80. Page 2

PUGET SOUND ENERGY

Attachment "C-1" Procedures, Terms & Conditions- Tier 1 Generating Facilities

- 6.0 The Company notifies the Interconnection Customer in writing that Interconnection of the Generating Facility is authorized once the Company has completed its inspection and a witness test. If the witness test is not satisfactory, the Company has the right to disconnect the Generating Facility. The Interconnection Customer has no right to operate in parallel until a witness test has been performed, or previously waived on the Application. The Company may waive the requirement of a witness test by so indicating on the application.
- 7.0 Contact Information – The Interconnection Customer must provide the contact information for the legal applicant. If another entity is responsible for interfacing with the Company, that contact information must be provided on the application.
- 8.0 Ownership Information – The legal names of the owner(s) of the Generating Facility must be included in the application. Include the percentage ownership (if any) by any utility or public utility holding company, or by any entity owned by either.
- 9.0 Inverter-Based Interconnections - UL1741 Listed - This standard ("Inverters, Converters, and Controllers for Use in Independent Power Systems") addresses the electrical Interconnection design of various forms of generating equipment. Many manufacturers submit their equipment to a Nationally Recognized Testing Laboratory (NRTL) that verifies compliance with UL1741. This "listing" is then marked on the equipment and supporting documentation. All inverter-based Interconnections must be UL 1741 listed and meet IEEE standards 1547 and 929.
- 10.0 The Generating Facility and Interconnection Facilities must be in compliance with: Company standards, Chapter 480-108 WAC, all applicable codes and standards for safe and reliable operation, and completion of an inspection and witness test by the Company.

PUGET SOUND ENERGY

Attachment "C-2" Procedures, Terms & Conditions - Tier 2 Generating Facilities

**SCHEDULE 80
PROCEDURES, AND TERMS AND CONDITIONS FOR INTERCONNECTING
A CERTIFIED INVERTER-BASED GENERATING FACILITY ELIGIBLE FOR TIER 2
("TIER 2 PROCESS")**

- 1.0 The Interconnection Customer completes the applicable Application in the form of (i) Attachment A to Schedule 150 or (ii) the Application in the form of Attachment A or B to Schedule 80 and submits it to the Company with the applicable non-refundable application fee.
- 2.0 Upon receipt the Company stamps the application with the date and time of receipt and within five business days the Company sends notice of receipt to the Interconnection Customer.
- 3.0 The Company evaluates the Application for completeness and notifies the Interconnection Customer within ten Business Days of receipt that the Application is or is not complete and, if not, advises what material is missing.
- 3.01 The Interconnection Customer must supply the necessary information for a complete Application or request an extension of time within fifteen business days. The Company is not obligated to grant a request for extension of time. If the Interconnection Customer does not provide the necessary information or request an extension of time that is granted by the Company within fifteen business days the application expires.
- 4.0 The Company verifies that the Generating Facility can be Interconnected safely and reliably and complies with the technical standards established in WAC 480-108-020 and the Company's standards. The Company has thirty business days following approval of a complete Application to complete this process and shall approve, approve with conditions, or deny the application with written justification. If delays result from unforeseen circumstances, Interconnection Customer variance requests, or other incentive program approval requirements, the Company shall promptly notify the Interconnection Customer.
- 4.01 For Interconnection Customers that do not complete Attachment A to Schedule 150, within five business days of notification of the approval described in 4.0 above the Company shall offer an executable Interconnection Agreement in the form of Attachment E or Attachment F to Schedule 80, whichever is appropriate.
- 4.02 The Interconnection Customer must Interconnect and operate the Generating Facility within one (1) year from the date of the Company's approval of the Application, or the Application expires, unless the Company, in its sole discretion, grants an extension in writing.
- 4.03 The Interconnection Customer, who has not executed Attachment A to Schedule 150, must execute and return the Interconnection Agreement within thirty business days and prior to physical Interconnection.

Issued: November 20, 2013

Effective: December 21, 2013

WN U-60

Attachment "C-2" to Schedule 80, Page 2

PUGET SOUND ENERGY

Attachment "C-2" Procedures, Terms & Conditions - Tier 2 Generating Facilities

- 5.0 After installation, the Interconnection Customer returns the Certificate of Completion to the Company. Prior to parallel operation, the Company may inspect the Generating Facility for compliance with standards which may include a witness test, and may schedule appropriate metering replacement, if necessary.
- 6.0 The Company notifies the Interconnection Customer in writing that Interconnection of the Generating Facility is authorized once the Company has completed its inspection and a witness test. If the witness test is not satisfactory, the Company has the right to disconnect the Generating Facility. The Interconnection Customer has no right to operate in parallel until a witness test has been performed, or previously waived on the Application. The Company may waive the requirement of a witness test by so indicating on the application.
- 7.0 Contact Information – The Interconnection Customer must provide the contact information for the legal applicant. If another entity is responsible for interfacing with the Company, that contact information must be provided on the application.
- 8.0 Ownership Information – The legal names of the owner(s) of the Generating Facility must be included in the application. Include the percentage ownership (if any) by any utility or public utility holding company, or by any entity owned by either.
- 9.0 Inverter-Based Interconnections - UL1741 Listed - This standard ("Inverters, Converters, and Controllers for Use in Independent Power Systems") addresses the electrical Interconnection design of various forms of generating equipment. Many manufacturers submit their equipment to a Nationally Recognized Testing Laboratory (NRTL) that verifies compliance with UL1741. This "listing" is then marked on the equipment and supporting documentation. All inverter-based Interconnections must be UL 1741 listed and meet IEEE standards 1547 and 929.
- 10.0 The Generating Facility and Interconnection Facilities must be in compliance with: Company standards, Chapter 480-108 WAC, all applicable codes and standards for safe and reliable operation, and completion of an inspection and witness test by the Company.

Issued: November 20, 2013

Effective: December 21, 2013

WN U-60

Attachment "C-3" to Schedule 80, Page 1

PUGET SOUND ENERGY

Attachment "C-3" Procedures, Terms & Conditions - Tier 3 Generating Facilities

**SCHEDULE 80
PROCEDURES, AND TERMS AND CONDITIONS FOR INTERCONNECTING
A CERTIFIED INVERTER-BASED GENERATING FACILITY ELIGIBLE FOR TIER 3
("TIER 3 PROCESS")**

- 1.0 The Interconnection Customer completes the applicable Application in the form of (i) Attachment A to Schedule 150 or (ii) the Application in the form of Attachment A or B to Schedule 80 and submits it to the Company with the applicable non-refundable application fee.
- 2.0 Upon receipt the Company stamps the application with the date and time of receipt and within five business days the Company sends notice of receipt to the Interconnection Customer.
- 3.0 The Company evaluates the Application for completeness and notifies the Interconnection Customer within ten Business Days of receipt that the Application is or is not complete and, if not, advises what material is missing.
- 3.01 The Interconnection Customer must supply the necessary information for a complete Application or request an extension of time within thirty business days. The Company is not obligated to grant a request for extension of time. If the Interconnection Customer does not provide the necessary information or request an extension of time that is granted by the Company within thirty business days the application expires.
- 4.0 The Company verifies that the Generating Facility can be Interconnected safely and reliably and complies with the technical standards established in WAC 480-108-020 and the Company's standards, and that no additional engineering, safety, reliability or other studies are required. The Company has thirty business days following approval of a complete Application to complete this process.
- 4.01 For Generating Facilities where the Company notifies the Interconnection Customer that the request complies with WAC 480-108-020 and Standards and that no additional studies are required to determine the feasibility of Interconnection, within five business days of notification of the approval described in 4.0 above the Company shall offer an executable Interconnection Agreement in the form of Attachment E or Attachment F to Schedule 80, whichever is appropriate. The Company shall also provide any additional agreements, such as, but not limited to, the Construction Agreement attached to this Schedule 80 as Attachment H that may be necessary along with a good faith estimate of the cost and time necessary to complete the Interconnection.
- 4.02 The Interconnection Customer must Interconnect and operate the Generating Facility within two (2) years from the date of the Company's approval of the Application, or the Application and the Interconnection Agreement expire, unless the Company, in its sole discretion, grants an extension in writing.
- 4.03 The Interconnection Customer, who has not executed Attachment A to Schedule 150, must execute and return the Interconnection Agreement within thirty business days and prior to physical Interconnection.

Issued: November 20, 2013
Effective: December 21, 2013

WN U-60

Attachment "C-3" to Schedule 80, Page 2

PUGET SOUND ENERGY

Attachment "C-3" Procedures, Terms & Conditions - Tier 3 Generating Facilities

- 4.1 If the Company, in its sole judgment, determines that additional studies are required to determine the feasibility of Interconnection, the Company must notify the Interconnection Customer within thirty business days of when the Application was deemed complete and provide the Interconnection Customer with a form agreement(s) that includes a description of what studies are required and a good faith estimate of the cost and time necessary to perform the studies. Such form agreement(s) shall be in the form of Attachments G through J to this Schedule 80, as appropriate.
- 4.11 The Interconnection Customer, within thirty business days of receiving the form agreement and cost estimate indicating additional studies are required, may provide an alternative cost estimate from a qualified third-party or return the completed agreement to the Company. After the Company and the Interconnection Customer agree on the estimated cost of the required study(ies), the Interconnection Customer must execute an agreement described in these studies and any deposit to be paid to the Company. The deposit shall not to exceed the lesser of one thousand dollars or fifty percent of the estimated cost of the studies. The balance of the costs are to be paid within 15 days following completion of the studies. The Company will make its best effort to complete the required studies, consistent with time requirements for the studies and other service requests of a similar magnitude.
- 4.12 The Interconnection Customer is responsible for all reasonable costs incurred by the Company to study the proposed Interconnection and to design and construct any required Interconnection Facilities or upgrades of the Company's electric system. The Interconnection Customer is responsible for reasonable ongoing operation and maintenance costs for facilities added to the Company's electric system that are dedicated to that Interconnection Customer's use.
- 4.13 The Company will provide the Interconnection Customer with the results of the study or studies. If the studies determine that Interconnection is not feasible, the Company will provide notice of denial and reasons for denial.
- 4.14 If the studies determine that Interconnection is feasible without upgrades of the Company's electric system, the Company will notify the Interconnection Customer and provide an executable Interconnection agreement within five business days of such notification, or if upgrades of the Company's electric system are required, within fifteen days of such notification. The Company will also provide any necessary additional agreements, such as construction agreements, and a good faith estimate of the cost and time necessary to complete the Interconnection. The Interconnection Customer must execute and return the agreements within thirty business days and pay any deposit required by the Company within thirty days of approval of the Application for Interconnection. The deposit shall not exceed fifty percent of the estimated costs to complete the Interconnection. The balance of the costs shall be paid within 15 days of completion of construction by the Company.
- 4.2 Failure of an Interconnection Customer to execute and return completed agreements and required deposits within time frames specified in this section 4 may result in termination of the application process.
- 4.3 Based on the results of the required studies, the Company and the Interconnection Customer may agree to modify the previously complete Application for the proposed Interconnection without penalty to the Interconnection Customer. The Company is under no obligation to

Issued: November 20, 2013

Effective: December 21, 2013

WN U-60

Attachment "C-3" to Schedule 80, Page 3

PUGET SOUND ENERGY

Attachment "C-3" Procedures, Terms & Conditions - Tier 3 Generating Facilities

agree to such modification, however if the Company agrees to such modification, the modified Application shall be considered an approved final Application.

- 4.4 Failure of the Interconnection Customer to execute, complete and return agreements and required deposits within the time frames specified herein may (in the sole judgment of the Company) result in termination of the application process.
- 4.5 Other than modification described in 4.3 above, changes by the Interconnection Customer to an Application approved by the Company will be considered a new Application and shall be accompanied by a new application fee. Denied Applications expire on the date of denial.
- 4.6 If the Company must upgrade or construct new electric facilities, the Interconnection Customer must meet the credit requirements of the Company prior to the start of construction.
- 5.0 After installation, the Interconnection Customer returns the Certificate of Completion to the Company. Prior to parallel operation, the Company may inspect the Generating Facility for compliance with standards which may include a witness test, and may schedule appropriate metering replacement, if necessary.
- 6.0 The Company notifies the Interconnection Customer in writing that Interconnection of the Generating Facility is authorized once the Company has completed its inspection and a witness test. If the witness test is not satisfactory, the Company has the right to disconnect the Generating Facility. The Interconnection Customer has no right to operate in parallel until a witness test has been performed, or previously waived on the Application. The Company may waive the requirement of a witness test by so indicating on the application.
- 7.0 Contact Information – The Interconnection Customer must provide the contact information for the legal applicant. If another entity is responsible for interfacing with the Company, that contact information must be provided on the application.
- 8.0 Ownership Information – The legal names of the owner(s) of the Generating Facility must be included in the application. Include the percentage ownership (if any) by any utility or public utility holding company, or by any entity owned by either.
- 9.0 Inverter-Based Interconnections - UL1741 Listed - This standard ("Inverters, Converters, and Controllers for Use in Independent Power Systems") addresses the electrical Interconnection design of various forms of generating equipment. Many manufacturers submit their equipment to a Nationally Recognized Testing Laboratory (NRTL) that verifies compliance with UL1741. This "listing" is then marked on the equipment and supporting documentation. All inverter-based Interconnections must be UL 1741 listed and meet IEEE standards 1547 and 929.
- 10.0 The Generating Facility and Interconnection Facilities must be in compliance with: Company standards, Chapter 480-108 WAC, all applicable codes and standards for safe and reliable operation, and completion of an inspection and witness test by the Company.

Issued: November 20, 2013
Effective: December 21, 2013

WN U-60

Attachment "D" to Schedule 80. Page 1

PUGET SOUND ENERGY

Attachment "D" Certificate of Completion

**SCHEDULE 80
TIER 1, 2, & 3 GENERATING FACILITY CERTIFICATE OF COMPLETION**

Is the Generating Facility owner-installed? Yes ___ No ___

Interconnection Customer: _____

Contact Person: _____

Address: _____

City: _____ State: _____ Zip Code: _____

Location of the Generating Facility (if different from above):

City: _____ State: _____ Zip Code: _____

Telephone (Day): _____ (Evening): _____

Fax: _____ E-Mail Address: _____

Electrician – Company Name: _____

Electrician's Name: _____

Address: _____

City: _____ State: _____ Zip Code: _____

Telephone (Day): _____ (Evening): _____

Fax: _____ E-Mail Address: _____

License Number: _____

Date of approval to install Generating Facility granted by PSE: _____

Application number: _____

Inspection:

The Generating Facility has been installed and inspected in compliance with the local building/
electrical code of _____

Signed (Local electrical wiring inspector, or attach signed electrical inspection):

Print Name: _____

Date: _____

As a condition of interconnection, you are required to send/fax a copy of this form along with a copy
of the signed electrical permit to (insert Company information below):

Issued: November 20, 2013
Effective: December 21, 2013

WN U-60

Attachment "D" to Schedule 80. Page 2

PUGET SOUND ENERGY

Attachment "D" Certificate of Completion

Name: _____
Company: Puget Sound Energy _____
Address: _____

City, State, ZIP: _____
Fax: _____

Contingent Approval to Interconnect a Tier 1 Generating Facility No Larger than 25 KW

(For Company use only)

Interconnecting the Generating Facility is approved contingent upon the Terms and Conditions for Interconnecting a Tier 1 Generating Facility No Larger than 25kW (See Attachment "C" to Schedule 80)

Company Signature: _____

Title: _____ Date: _____

Application number: _____

Company waives inspection and witness test? Yes ___ No ___

Contingent Approval to energize a Generating Facility other than an Tier 2 Generating Facility No Larger than 25 kW

(For Company Use Only)

Interconnection of the Generating Facility is approved contingent upon execution of an Interconnection Agreement, compliance with Company standards, compliance with Chapter 480-108 WAC, compliance with all applicable codes and standards for safe and reliable operation and completion of an inspection and witness test by the Company.

Company Signature: _____

Title: _____ Date: _____

Application number: _____

Issued: November 20, 2013

Effective: December 21, 2013

WN U-60

Attachment "E" to Schedule 80, Page 1

PUGET SOUND ENERGY

Attachment "E" Interconnection Agreement

**SCHEDULE 80
INTERCONNECTION AGREEMENT**

Tier 1 Interconnection Agreement

Interconnection Customer

This Interconnection Agreement is executed in duplicate this ____ day of _____, 20____ between _____ (hereinafter referred to as "Interconnection Customer"), and Puget Sound Energy, Inc. (the "Company" or "PSE"). Both parties, who may be herein further referred to collectively as "Parties" and individually as "Party", agree as follows:

1.0 DEFINITION

When used in this Agreement with initial capitalization, the terms used in this Agreement shall have the meanings indicated or the meanings specified in Schedule 80.

2.0 INTERCONNECTION CUSTOMER ELECTRIC GENERATING FACILITY

- 2.1 Interconnection Customer has elected to operate in parallel with the Company's transmission and distribution facilities a Generating Facility with a generating capacity of not more than twenty-five (25) kilowatts that is eligible under Tier 1. Interconnection Customer.
- 2.2 The Company will provide wheeling for Interconnection Customer's Generating Facility only under a separate agreement. Interconnection Customer
- 2.3 Interconnection Customer's Application, including the location of the electrical generating installation facility and details on the electrical generating unit(s), is hereby incorporated into this agreement as Attachment A.
- 2.4 The installation is identified by the Company with the following designators: Transformer No. (feeder and phase) _____, Interconnection Customer Utility Account No. _____.
- 2.5 The electrical generating system facility used by the Interconnection Customer shall be located on the Interconnection Customer's premises. Interconnection Customer shall be obligated to include in such facility all equipment necessary to meet applicable safety, power quality, and Interconnection requirements established by the National Electrical Code (Articles 690 and 705), National Electrical Safety Code, the Institute of Electrical and Electronics Engineers, Underwriters Laboratories, and the Company's Interconnection Standards, as set forth in the attached Attachment B.
- 2.6 The Company shall have the sole authority to determine which Interconnection requirements set forth herein are applicable to Interconnection Customer's proposed Generating Facility.

Issued: November 20, 2013

Effective: December 21, 2013

WN U-60

Attachment "E" to Schedule 80, Page 2

PUGET SOUND ENERGY

Attachment "E" Interconnection Agreement

3.0 DISCONNECTION, INTERRUPTION OR REDUCTION OF DELIVERIES

- 3.1 The Company may require Interconnection Customer to interrupt or reduce deliveries as follows:
- a. when necessary in order to construct, install, maintain, repair, replace, remove, investigate, or inspect any of its equipment or part of its system; or
 - b. if the Company determines that curtailment, interruption, or reduction is necessary because of emergencies, force or compliance with prudent electrical practices.
- 3.2 Whenever possible, the Company shall give Interconnection Customer reasonable notice of the possibility that interruption or reduction of deliveries may be required.
- 3.3 Notwithstanding any other provision of this Agreement, if at any time the Company determines that either:
- a. the Generating Facility may endanger Company personnel, or
 - b. the continued operation of Interconnection Customer's Generating Facility may endanger the integrity of the Company's electric system,

then the Company shall have the right to temporarily or permanently disconnect Interconnection Customer Generating Facility from the Company's electric system. Interconnection Customer's Generating Facility shall remain disconnected until such time as the Company is satisfied that the condition(s) referred to in (a) of (b) of this section 3.3 has been corrected. If the Interconnection Customer has not provided a separate point of disconnection for the Generating Facility, such disconnection will result in disconnection of Electric Service to the Interconnection Customer. Such disconnection may be completed without notice as contemplated in WAC 480-100.

4.0 INTERCONNECTION

- 4.1 Interconnection Customer shall deliver the energy to the Company at the Company's meter.
- 4.2 Interconnection Customer shall pay for designing, installing, inspecting, operating, and maintaining the electric Generating Facility in accordance with all applicable laws and regulations and shall comply with the Company's Interconnection Standards and all technical standards set forth in WAC Chapter 480-108.
- 4.3 Interconnection Customer shall pay for the Company's standard watt-hour meter electrical hook-up, if not already present.
- 4.4 Interconnection Customer shall not commence parallel operation of the Generating Facility until written approval of the Interconnection facilities has been given by the Company. Such approval shall not be unreasonably withheld. The Company shall have the right to have representatives present at the initial testing of Interconnection Customer's protective apparatus. Interconnection Customer shall provide the Company with reasonable advance notice as to when testing is to take place.

PUGET SOUND ENERGY

Attachment "E" Interconnection Agreement

5.0 MAINTENANCE AND PERMITS:

Interconnection Customer shall:

- a. maintain the electric Generating Facility and Interconnection facilities in a safe and prudent manner and in conformance with all applicable laws and regulations including, but not limited to, the Company's Interconnection Standards and chapter 480-108 WAC,
- b. obtain any governmental authorizations and permits required for the construction and operation of the electric Generating Facility and Interconnection facilities, including electrical permit(s), and
- c. reimburse the Company for any and all losses, damages, claims, penalties, or liability the Company incurs as a result of Interconnection Customer's failure to obtain or maintain any governmental authorizations and permits required for construction and operation of Interconnection Customer's Generating Facility or failure to maintain Interconnection Customer's Generating Facility as required in Section 5.a.

6.0 ACCESS TO PREMISES

6.1 The Company may enter Interconnection Customer's premises or property to:

- a. inspect, with prior notice, at all reasonable hours, Interconnection Customer's Generating Facility's protective devices;
- b. read meter; and
- c. disconnect at the Company's meter or transformer, without notice, the Generating Facilities if, in the Company's opinion, a hazardous condition exists and such immediate action is necessary to protect persons, or the Company's facilities, or property of others from damage or interference caused by Interconnection Customer's electric Generating Facilities, or lack of properly operating protective devices or inability to inspect the same.

6.2 The Company inspection or other action shall not constitute approval by the Company. The Interconnection Customer remains solely responsible for the safe, reliable and adequate operation of its facilities.

7.0 INDEMNITY AND LIABILITY

7.1 The Interconnection Customer assumes the risk of all damages, losses, costs and expenses and agrees to indemnify the Company, its successors and assigns, and their respective directors, officers, employees and agents, from and against any and all claims, losses, costs, liabilities, damages and expenses including, but not limited to, reasonable attorneys' fees, resulting from or in connection with performance of this Agreement or which may occur or be sustained by the Company on account of any claim or action brought against the Company for any reason, including, but not limited to, loss to the electrical system of the Interconnection Customer caused by or arising out of any electrical disturbance.

Issued: November 20, 2013

Effective: December 21, 2013

WN U-60

Attachment "E" to Schedule 80. Page 4

PUGET SOUND ENERGY

Attachment "E" Interconnection Agreement

- 7.2 The Interconnection Customer assumes the risk of all damages, losses, costs and expenses and agrees to indemnify the Company, its successors and assigns, and their respective directors, officers, employees and agents, from and against any and all claims, losses, costs, liabilities, damages and expenses including, but not limited to, reasonable attorneys' fees, resulting from the death or bodily injury to any person, including, but not limited to, the officers, employees, agents and subcontractors of either Party hereto, to the extent arising out of the Interconnection Customer's negligence or willful misconduct. In connection with any action to enforce the Interconnection Customer's obligations under this Section 7.2 with respect to any claim arising out of bodily injury (including death) of any employee of Interconnection Customer, Interconnection Customer waives any immunity, defense or other protection that may be afforded by any workers' compensation, industrial insurance or similar laws (including, but not limited to, the Washington Industrial Insurance Act, Title 51 RCW). This Section 7.2 will not be interpreted or construed as a waiver of Interconnection Customer's right to assert any such immunity, defense or protection directly against any of its own employees or such employee's estate or other representatives.
- 7.3 The provisions of this Section 7 shall not be construed to relieve any insurer of its obligations to pay any insurance claims in accordance with the provisions of any insurance policy.
- 7.4 The Company shall have no liability, ownership interest, control or responsibility for the Interconnection Customer's Electric Generating Facility or its Interconnection with the Company's electric system, regardless of what the Company knows or should know about the Interconnection Customer's Electric Generating Facility or its Interconnection.

8.0 INDEPENDENT CONTRACTORS

The Parties hereto are independent contractors and shall not be deemed to be partners, joint venturers, employees, franchisees or franchisers, servants or agents of each other for any purpose whatsoever under or in Interconnection with this Agreement.

9.0 GOVERNING LAW

This Agreement shall be interpreted, governed, and constructed under the laws of the State of Washington as if executed and to be performed wholly within the State of Washington. Venue of any action arising hereunder or related to this agreement shall lie in King County, Washington.

10.0 FUTURE MODIFICATION OR EXPANSION

Any future modification or expansion of the Interconnection Customer owned Generating Facility will require an engineering, safety and reliability review and approval by the Company. The Company reserves the right to deny the modification or expansion or to require the Interconnection Customer, at Interconnection Customer's expense, to provide modifications or additions to existing electrical devices including, but not limited to, protection device and meters, in the event of changes to government or industry regulation and/or standards.

Issued: November 20, 2013
Effective: December 21, 2013

WN U-60 Attachment "E" to Schedule 80. Page 5

PUGET SOUND ENERGY

Attachment "E" Interconnection Agreement

11.0 AMENDMENTS, MODIFICATIONS OR WAIVER

Any amendments or modifications to this Agreement shall be in writing and shall only be as hereafter agreed to by both Parties. The failure of any Party at any time or times to require performance of any provision hereof shall in no manner affect the right at a later time to enforce the same. No waiver by any Party of the breach of any term or covenant contained in this Agreement, whether by conduct or otherwise, shall be deemed to be a further or continuing waiver of the same or any similar breach.

12.0 ASSIGNMENT

The Interconnection Customer shall not assign its rights under this Agreement without the express written consent of the Company, which consent the Company may withhold in its sole discretion.

13.0 APPENDICES

The Agreement includes the following appendices attached and incorporated by reference: Attachment A: Application for Interconnection in the form of Attachment A to Schedule 80.

14.0 NOTICES

All written notices shall be directed as follows:

Contact Name and address of PSE:

Puget Sound Energy, Inc.

Attn: _____
Contact Name

Address

City, State & Zip

Interconnection Customer:

Name

Address

City, State & Zip

Interconnection Customer's notices to the Company, pursuant to this Section 14, shall refer to the Service Address set forth in Appendix A, Application for Net Metered Electrical Generation.

Issued: November 20, 2013

Effective: December 21, 2013

WN U-60

Attachment "E" to Schedule 80, Page 6

PUGET SOUND ENERGY

Attachment "E" Interconnection Agreement

15.0 TERM OF AGREEMENT

This Agreement shall be in effect when signed and delivered by the Interconnection Customer and the Company and shall remain in effect thereafter unless terminated by either Party on thirty (30) days' prior written notice in accordance with Section 14.

16.0 SIGNATURES

IN WITNESS WHEREOF, the Parties have caused to originals of this Agreement to be executed by their duly authorized representatives as of the date first written above.

This Agreement is effective as of the last date set forth below.

INTERCONNECTION CUSTOMER []	PUGET SOUND ENERGY, INC.:
Signature	Signature
Print name	Print name
Title	Title

Issued: November 20, 2013

Effective: December 21, 2013

WN U-60

Attachment "E" to Schedule 80, Page 7

PUGET SOUND ENERGY

Attachment "E" Interconnection Agreement

Attachment "B" to INTERCONNECTION AGREEMENT

Puget Sound Energy Standard 6325.4000

Please note that the attached standard is subject to revision by the Company. The most current version is always available upon request from the Company and the most current version will be attached to any Interconnection Agreement provided to a Customer.

Issued: November 20, 2013

Effective: December 21, 2013

WN U-60

Attachment "E" to Schedule 80, Page 8

PUGET SOUND ENERGY

Attachment "E" Interconnection Agreement

Attachment "B" to INTERCONNECTION AGREEMENT

Puget Sound Energy Standard 6325.4000

**Schedule 150 Net Metering for
Customer-Generator Systems**

6325.4000

Scope This standard establishes the requirements for connecting, metering, and documenting customer-generators who operate fuel cell, hydroelectric, solar, or wind power generators with a total capacity of no more than 100 kW on their own premises operating in parallel with Puget Sound Energy's distribution system.

General Requirements

Customer-owned generators up to 25 kW total output may be connected to and operate in parallel to Puget Sound Energy's facilities in accordance with Electric Tariff G, Schedule 150, Net Metering Services for Renewable Energy Systems. All customer electrical equipment must comply with the NEC and any state or local code requirements.

Quality of Service

Service Voltage The customer shall be only served by a standard service voltage given in Standard 0650.2000, "Standard Service Voltage." The customer's system shall not cause the voltage at the Point of Delivery to exceed the limits listed in this standard.

Voltage Flicker The customer's installation shall meet the requirements of Standard 0650.4100, "Voltage Flicker."

Harmonics The customer's installation shall meet the requirements of Standard 0650.4200, "Harmonics."

Disconnect Switch

To satisfy the requirements of WAC 296-45-335, "De-energizing Lines and Equipment for Employee Protection," PSE must have the ability to disconnect a generator from PSE's system. If a customer's system output is 5 kW or less and it is not CT metered, PSE will use the meter as the disconnection point.

If the customer's system output is greater than 5 kW, or the customer's service is CT metered, the customer must install a lockable disconnect switch. This lockable disconnect switch must be adjacent to the service meter and accessible to PSE personnel at all times. This switch shall be assigned a PSE switch number.

Issued: November 20, 2013

Effective: December 21, 2013

WN U-60

Attachment "E" to Schedule 80, Page 9

PUGET SOUND ENERGY

Attachment "E" Interconnection Agreement

Attachment "B" to INTERCONNECTION AGREEMENT (Continued)

Puget Sound Energy Standard 6325.4000

**Schedule 150 Net Metering for
 Customer-Generator Systems**

6325.4000

Responsibilities

A customer-owned generation that operates in parallel with PSE's system is uncommon, and many departments of the company should be involved when integrating it into the distribution system. Table 1 provides an outline of some of the roles and responsibilities.

Table 1

Who	Action
Energy Efficiency Services	<ul style="list-style-type: none"> Provides a single point of contact for the customer. Obtains a Net Metering Agreement from the customer. Disseminates information to PSE departments and coordinates PSE's activities.
System Protection	<ul style="list-style-type: none"> Reviews the proposed generation design for safety and reliability.
Meter Engineering	<ul style="list-style-type: none"> Orders and programs the meter. Obtains a switch number from System Operations for the disconnect switch (if installed).
System Operations	<ul style="list-style-type: none"> Assigns a switch number for the disconnect switch. Updates system maps and mimic board.
First Response	<ul style="list-style-type: none"> Verifies the transformer is adequately sized.
Customer Billing	<ul style="list-style-type: none"> Sets up a Net Metering account.
Substation Meter Relay Technician	<ul style="list-style-type: none"> Sets the meter. Labels the disconnect switch, if any, with PSE's switch number. Completes the Interconnection Equipment Testing and Verification checklist (Form 2930) Completes the One Line Diagram (Form 2928 or 2929). See the attached examples.
Maps and Records	<ul style="list-style-type: none"> Maps the generation facility onto the U-map and circuit maps.

Issued: November 20, 2013
Effective: December 21, 2013
WN U-60 Attachment "E" to Schedule 80, Page 10

PUGET SOUND ENERGY

Attachment "E" Interconnection Agreement

Attachment "B" to INTERCONNECTION AGREEMENT (Continued)

Puget Sound Energy Standard 6325.4000

Schedule 150 Net Metering for
Customer-Generator Systems

6325.4000

One-Line Diagram (Systems up to 5 kW Output) Form 2928

SCHEDULE 150
CUSTOMER GENERATOR SYSTEMS

Typical One-Line Diagram: **Up to 5 kW Total Output**

GENERATOR TYPE:
 FUEL CELL SOLAR WIND HYDROELECTRIC

TOTAL KW OUTPUT: _____
MAXIMUM FAULT CURRENT: _____ A @ _____ VOLTS
SERVICE ADDRESS: _____

FUEL CELL
OR
SOLAR
OR
WIND
OR
HYDROELECTRIC

INVERTER (If Present) Islanding Non-Islanding

ELECTRIC BREAKER PANEL

UTILITY GRID

TRANSFORMER KVA & GRID #

KWH METER #

PSE REP. _____ DATE _____

5428 (A)(K)

Issued: November 20, 2013
 Effective: December 21, 2013
 Attachment "E" to Schedule 80, Page 11
 WN U-60

PUGET SOUND ENERGY

Attachment "E" Interconnection Agreement

Attachment "B" to INTERCONNECTION AGREEMENT (Continued)

Puget Sound Energy Standard 6325.4000

Schedule 150 Net Metering for
 Customer-Generator Systems

6325.4000

One-Line Diagram (Systems 5 kW to 25 kW Output) Form 2929



SCHEDULE 150
CUSTOMER GENERATOR SYSTEMS

SAMPLE

Typical One-Line Diagram: 5 kW to 25 kW Total Output

GENERATOR TYPE:
 FUEL CELL SOLAR WIND HYDROELECTRIC

TOTAL KW OUTPUT: _____

MAXIMUM FAULT CURRENT: _____ A @ _____ VOLTS

SERVICE ADDRESS: _____

FUEL CELL 

OR

SOLAR 

OR

WIND 

OR

HYDROELECTRIC 

INVERTER (If Present) Islanding Non-Islanding

ELECTRIC BREAKER PANEL

KWH METER# SWITCH#

UTILITY GRID ————

TRANSFORMER KVA & GRID # _____

OUTDOOR LOCKING DISCONNECT SWITCH (PSE ACCESSIBLE)

Describe physical location of outdoor locking disconnect switch in relation to KWH Meter:

PSE REP. _____ DATE _____

2929 (8/07)

Issued: November 20, 2013
Effective: December 21, 2013

WN U-60 Attachment "E" to Schedule 80, Page 12

PUGET SOUND ENERGY

Attachment "E" Interconnection Agreement

Attachment "B" to INTERCONNECTION AGREEMENT (Continued)

Puget Sound Energy Standard 6325.4000

**Schedule 150 Net Metering for
Customer-Generator Systems**

6325.4000

References

The following Puget Sound Energy documents apply to this standard:

0650.2000 Standard Service Voltages
0650.4100 Voltage Flicker
0650.4200 Harmonics

Electric Schedule 150, Net Metering Services for Customer Generator Systems

Sources

WAC 296-45-335 De-energizing Lines and Equipment for Employee Protection

Issued: November 20, 2013

Effective: December 21, 2013

WN U-60

Attachment "E-2" to Schedule 80, Page 1

PUGET SOUND ENERGY

Attachment "E-2" Interconnection Agreement

**SCHEDULE 80
INTERCONNECTION AGREEMENT**

**Tier 2 Interconnection Agreement For Interconnection Customer Eligible For Net Metering
Under Schedule 150**

**Customer Generator Owned Fuel Cell, Solar, Wind,
Biogas, Combined Heat and Power or Hydropower
Electric Generating Facilities of 100 Kilowatts or Less**

This Net Energy Metering Interconnection Agreement is executed in duplicate this ____ day of _____, 20____ between _____ (hereinafter referred to as "Customer Generator" or "Interconnection Customer"), and Puget Sound Energy, Inc. (the "Company" or "PSE"). Both parties, who may be herein further referred to collectively as "Parties" and individually as "Party", agree as follows:

1.0 DEFINITION

When used in this Agreement with initial capitalization, the terms used in this Agreement shall have the meanings indicated or the meanings specified in Schedule 150 and Schedule 80.

2.0 INTERCONNECTION CUSTOMER ELECTRIC GENERATING FACILITY

- 2.1 Interconnection Customer has elected, in accordance with RCW 80.60 *et seq.*, to operate in parallel with the Company's transmission and distribution facilities either a net energy metered fuel cell facility that produces electricity and used and useful thermal energy from a common fuel source, or a facility that uses water, wind, solar energy, or biogas from animal waste as a fuel as set forth in chapter 80.60 RCW with a Generating Facility with a generating capacity of not more than twenty-five (25) kilowatts that is eligible under Tier 2. The Customer Generator is therefore an Interconnection Customer and the operator of a Net Metering System. The Customer Generator's electric Generating Facility is intended to offset either part or all of the Customer Generator's electrical requirements.
- 2.2 The Company will provide wheeling for Interconnection Customer's Generating Facility only under a separate agreement. Interconnection Customer
- 2.3 Interconnection Customer's Application, including the location of the electrical generating installation facility and details on the electrical generating unit(s), is hereby incorporated into this agreement as Attachment A.
- 2.4 The net metering installation is identified by the Company with the following designators: Transformer No. (feeder and phase) _____, Interconnection Customer Utility Account No. _____.

Issued: November 20, 2013

Effective: December 21, 2013

WN U-60

Attachment "E-2" to Schedule 80. Page 2

PUGET SOUND ENERGY

Attachment "E-2" Interconnection Agreement

- 2.5 The electrical generating system facility used by the Interconnection Customer shall be located on the Interconnection Customer's premises. Interconnection Customer shall be obligated to include in such facility all equipment necessary to meet applicable safety, power quality, and Interconnection requirements established by the National Electrical Code (Articles 690 and 705), National Electrical Safety Code, the Institute of Electrical and Electronics Engineers, Underwriters Laboratories, and the Company's Net Metering and Interconnection Standards, as set forth in the attached Attachment B.
- 2.6 The Company shall have the sole authority to determine which Interconnection requirements set forth herein are applicable to Interconnection Customer's proposed Generating Facility.
- 3.0 DISCONNECTION, INTERRUPTION OR REDUCTION OF DELIVERIES**
- 3.1 The Company may require Interconnection Customer to interrupt or reduce deliveries as follows:
- a. when necessary in order to construct, install, maintain, repair, replace, remove, investigate, or inspect any of its equipment or part of its system; or
 - b. if the Company determines that curtailment, interruption, or reduction is necessary because of emergencies, force or compliance with prudent electrical practices.
- 3.2 Whenever possible, the Company shall give Interconnection Customer reasonable notice of the possibility that interruption or reduction of deliveries may be required.
- 3.3 Notwithstanding any other provision of this Agreement, if at any time the Company determines that either:
- a. the Generating Facility may endanger Company personnel, or
 - b. the continued operation of Interconnection Customer's Generating Facility may endanger the integrity of the Company's electric system,
- then the Company shall have the right to temporarily or permanently disconnect Interconnection Customer Generating Facility from the Company's electric system. Interconnection Customer's Generating Facility shall remain disconnected until such time as the Company is satisfied that the condition(s) referred to in (a) of (b) of this section 3.3 has been corrected. If the Interconnection Customer has not provided a separate point of disconnection for the Generating Facility, such disconnection will result in disconnection of Electric Service to the Interconnection Customer. Such disconnection may be completed without notice as contemplated in WAC 480-100.
- 4.0 INTERCONNECTION**
- 4.1 Interconnection Customer shall deliver the energy to the Company at the Company's meter.
- 4.2 Interconnection Customer shall pay for designing, installing, inspecting, operating, and maintaining the electric Generating Facility in accordance with all applicable laws and regulations and shall comply with the Company's Interconnection Standards and all technical standards set forth in WAC Chapter 480-108.

Issued: November 20, 2013

Effective: December 21, 2013

WN U-60

Attachment "E-2" to Schedule 80, Page 3

PUGET SOUND ENERGY

Attachment "E-2" Interconnection Agreement

- 4.3 Interconnection Customer shall pay for the Company's standard watt-hour meter electrical hook-up, if not already present.
- 4.4 Interconnection Customer shall not commence parallel operation of the Generating Facility until written approval of the Interconnection facilities has been given by the Company. Such approval shall not be unreasonably withheld. The Company shall have the right to have representatives present at the initial testing of Interconnection Customer's protective apparatus. Interconnection Customer shall provide the Company with reasonable advance notice as to when testing is to take place.
- 5.0 MAINTENANCE AND PERMITS:
- Interconnection Customer shall:
- a. maintain the electric Generating Facility and Interconnection facilities in a safe and prudent manner and in conformance with all applicable laws and regulations including, but not limited to, the Company's Interconnection Standards and chapter 480-108 WAC,
 - b. obtain any governmental authorizations and permits required for the construction and operation of the electric Generating Facility and Interconnection facilities, including electrical permit(s), and
 - c. reimburse the Company for any and all losses, damages, claims, penalties, or liability the Company incurs as a result of Interconnection Customer's failure to obtain or maintain any governmental authorizations and permits required for construction and operation of Interconnection Customer's Generating Facility or failure to maintain Interconnection Customer's Generating Facility as required in Section 5.a.
- 6.0 ACCESS TO PREMISES
- 6.1 The Company may enter Interconnection Customer's premises or property to:
- a. inspect, with prior notice, at all reasonable hours, Interconnection Customer's Generating Facility's protective devices;
 - b. read meter; and
 - c. disconnect at the Company's meter or transformer, without notice, the Generating Facilities if, in the Company's opinion, a hazardous condition exists and such immediate action is necessary to protect persons, or the Company's facilities, or property of others from damage or interference caused by Interconnection Customer's electric Generating Facilities, or lack of properly operating protective devices or inability to inspect the same.
- 6.2 The Company inspection or other action shall not constitute approval by the Company. The Interconnection Customer remains solely responsible for the safe, reliable and adequate operation of its facilities.

Issued: November 20, 2013

Effective: December 21, 2013

WN U-60

Attachment "E-2" to Schedule 80, Page 4

PUGET SOUND ENERGY

Attachment "E-2" Interconnection Agreement

7.0 INDEMNITY AND LIABILITY

- 7.1 The Interconnection Customer assumes the risk of all damages, losses, costs and expenses and agrees to indemnify the Company, its successors and assigns, and their respective directors, officers, employees and agents, from and against any and all claims, losses, costs, liabilities, damages and expenses including, but not limited to, reasonable attorneys' fees, resulting from or in connection with performance of this Agreement or which may occur or be sustained by the Company on account of any claim or action brought against the Company for any reason, including, but not limited to, loss to the electrical system of the Interconnection Customer caused by or arising out of any electrical disturbance.
- 7.2 The Interconnection Customer assumes the risk of all damages, losses, costs and expenses and agrees to indemnify the Company, its successors and assigns, and their respective directors, officers, employees and agents, from and against any and all claims, losses, costs, liabilities, damages and expenses including, but not limited to, reasonable attorneys' fees, resulting from the death or bodily injury to any person, including, but not limited to, the officers, employees, agents and subcontractors of either Party hereto, to the extent arising out of the Interconnection Customer's negligence or willful misconduct. In connection with any action to enforce the Interconnection Customer's obligations under this Section 7.2 with respect to any claim arising out of bodily injury (including death) of any employee of Interconnection Customer, Interconnection Customer waives any immunity, defense or other protection that may be afforded by any workers' compensation, industrial insurance or similar laws (including, but not limited to, the Washington Industrial Insurance Act, Title 51 RCW). This Section 7.2 will not be interpreted or construed as a waiver of Interconnection Customer's right to assert any such immunity, defense or protection directly against any of its own employees or such employee's estate or other representatives.
- 7.3 The provisions of this Section 7 shall not be construed to relieve any insurer of its obligations to pay any insurance claims in accordance with the provisions of any insurance policy.
- 7.4 The Company shall have no liability, ownership interest, control or responsibility for the Interconnection Customer's Electric Generating Facility or its Interconnection with the Company's electric system, regardless of what the Company knows or should know about the Interconnection Customer's Electric Generating Facility or its Interconnection.

8.0 INDEPENDENT CONTRACTORS

The Parties hereto are independent contractors and shall not be deemed to be partners, joint venturers, employees, franchisees or franchisers, servants or agents of each other for any purpose whatsoever under or in Interconnection with this Agreement.

9.0 GOVERNING LAW

This Agreement shall be interpreted, governed, and constructed under the laws of the State of Washington as if executed and to be performed wholly within the State of Washington. Venue of any action arising hereunder or related to this agreement shall lie in King County, Washington.

Issued: November 20, 2013

Effective: December 21, 2013

WN U-60

Attachment "E-2" to Schedule 80, Page 5

PUGET SOUND ENERGY

Attachment "E-2" Interconnection Agreement

10.0 FUTURE MODIFICATION OR EXPANSION

Any future modification or expansion of the Interconnection Customer owned Generating Facility will require an engineering, safety and reliability review and approval by the Company. The Company reserves the right to deny the modification or expansion or to require the Interconnection Customer, at Interconnection Customer's expense, to provide modifications or additions to existing electrical devices including, but not limited to, protection device and meters, in the event of changes to government or industry regulation and/or standards.

11.0 AMENDMENTS, MODIFICATIONS OR WAIVER

Any amendments or modifications to this Agreement shall be in writing and shall only be as hereafter agreed to by both Parties. The failure of any Party at any time or times to require performance of any provision hereof shall in no manner affect the right at a later time to enforce the same. No waiver by any Party of the breach of any term or covenant contained in this Agreement, whether by conduct or otherwise, shall be deemed to be a further or continuing waiver of the same or any similar breach.

12.0 ASSIGNMENT

The Interconnection Customer shall not assign its rights under this Agreement without the express written consent of the Company, which consent the Company may withhold in its sole discretion.

13.0 APPENDICES

The Agreement includes the following appendices attached and incorporated by reference: Attachment A: Application for Interconnection in the form of Attachment A to Schedule 80.

14.0 NOTICES

All written notices shall be directed as follows:

Contact Name and address of PSE:

Puget Sound Energy, Inc.

Attn: _____

Contact Name

Address

City, State & Zip

Issued: November 20, 2013
 Effective: December 21, 2013

WN U-60 Attachment "E-2" to Schedule 80, Page 6

PUGET SOUND ENERGY

Attachment "E-2" Interconnection Agreement

Interconnection Customer:

 Name

 Address

 City, State & Zip

Interconnection Customer's notices to the Company, pursuant to this Section 14, shall refer to the Service Address set forth in Appendix A, Application for Net Metered Electrical Generation.

15.0 TERM OF AGREEMENT

This Agreement shall be in effect when signed and delivered by the Interconnection Customer and the Company and shall remain in effect thereafter unless terminated by either Party on thirty (30) days' prior written notice in accordance with Section 14.

16.0 SIGNATURES

IN WITNESS WHEREOF, the Parties have caused to originals of this Agreement to be executed by their duly authorized representatives as of the date first written above.

This Agreement is effective as of the last date set forth below.

INTERCONNECTION CUSTOMER [REDACTED]	PUGET SOUND ENERGY, INC.:
Signature	Signature
Print name	Print name
Title	Title

Issued: November 20, 2013

Effective: December 21, 2013

WN U-60

Attachment "E-2" to Schedule 80, Page 7

PUGET SOUND ENERGY

Attachment "E-2" Interconnection Agreement

Attachment "B" to **INTERCONNECTION AGREEMENT**

Puget Sound Energy Standard 6325.4000

Please note that the attached standard is subject to revision by the Company. The most current version is always available upon request from the Company and the most current version will be attached to any Interconnection Agreement provided to a Customer.

Issued: November 20, 2013
Effective: December 21, 2013

WN U-60 Attachment "E-2" to Schedule 80, Page 8

PUGET SOUND ENERGY

Attachment "E-2" Interconnection Agreement

Attachment "B" to INTERCONNECTION AGREEMENT

Puget Sound Energy Standard 6325.4000

**Schedule 150 Net Metering for
Customer-Generator Systems**

6325.4000

Scope This standard establishes the requirements for connecting, metering, and documenting customer-generators who operate fuel cell, hydroelectric, solar, or wind power generators with a total capacity of no more than 100 kW on their own premises operating in parallel with Puget Sound Energy's distribution system.

General Requirements

Customer-owned generators up to 25 kW total output may be connected to and operate in parallel to Puget Sound Energy's facilities in accordance with Electric Tariff G, Schedule 150, Net Metering Services for Renewable Energy Systems. All customer electrical equipment must comply with the NEC and any state or local code requirements.

Quality of Service

Service Voltage The customer shall be only served by a standard service voltage given in Standard 0650.2000, "Standard Service Voltage." The customer's system shall not cause the voltage at the Point of Delivery to exceed the limits listed in this standard.

Voltage Flicker The customer's installation shall meet the requirements of Standard 0650.4100, "Voltage Flicker."

Harmonics The customer's installation shall meet the requirements of Standard 0650.4200, "Harmonics."

Disconnect Switch

To satisfy the requirements of WAC 296-45-335, "De-energizing Lines and Equipment for Employee Protection," PSE must have the ability to disconnect a generator from PSE's system. If a customer's system output is 5 kW or less and it is not CT metered, PSE will use the meter as the disconnection point.

If the customer's system output is greater than 5 kW, or the customer's service is CT metered, the customer must install a lockable disconnect switch. This lockable disconnect switch must be adjacent to the service meter and accessible to PSE personnel at all times. This switch shall be assigned a PSE switch number.

Issued: November 20, 2013
 Effective: December 21, 2013

WN U-60 Attachment "E-2" to Schedule 80, Page 9

PUGET SOUND ENERGY

Attachment "E-2" Interconnection Agreement

Attachment "B" to INTERCONNECTION AGREEMENT (Continued)

Puget Sound Energy Standard 6325.4000

**Schedule 150 Net Metering for
 Customer-Generator Systems**

6325.4000

Responsibilities

A customer-owned generation that operates in parallel with PSE's system is uncommon, and many departments of the company should be involved when integrating it into the distribution system. Table 1 provides an outline of some of the roles and responsibilities.

Table 1

Who	Action
Energy Efficiency Services	<ul style="list-style-type: none"> Provides a single point of contact for the customer. Obtains a Net Metering Agreement from the customer. Disseminates information to PSE departments and coordinates PSE's activities.
System Protection	<ul style="list-style-type: none"> Reviews the proposed generation design for safety and reliability.
Meter Engineering	<ul style="list-style-type: none"> Orders and programs the meter. Obtains a switch number from System Operations for the disconnect switch (if installed).
System Operations	<ul style="list-style-type: none"> Assigns a switch number for the disconnect switch. Updates system maps and mimic board.
First Response	<ul style="list-style-type: none"> Verifies the transformer is adequately sized.
Customer Billing	<ul style="list-style-type: none"> Sets up a Net Metering account.
Substation Meter Relay Technician	<ul style="list-style-type: none"> Sets the meter. Labels the disconnect switch, if any, with PSE's switch number. Completes the Interconnection Equipment Testing and Verification checklist (Form 2930) Completes the One Line Diagram (Form 2928 or 2929). See the attached examples.
Maps and Records	<ul style="list-style-type: none"> Maps the generation facility onto the U-map and circuit maps.

WN U-60
Attachment "E-2" to Schedule 80, Page 10

Issued: November 20, 2013
Effective: December 21, 2013

PUGET SOUND ENERGY

Attachment "E-2" Interconnection Agreement

Attachment "B" to INTERCONNECTION AGREEMENT (Continued)

Puget Sound Energy Standard 6325.4000

Schedule 150 Net Metering for
Customer-Generator Systems

6325.4000

One-Line Diagram (Systems up to 5 kW Output) Form 2928

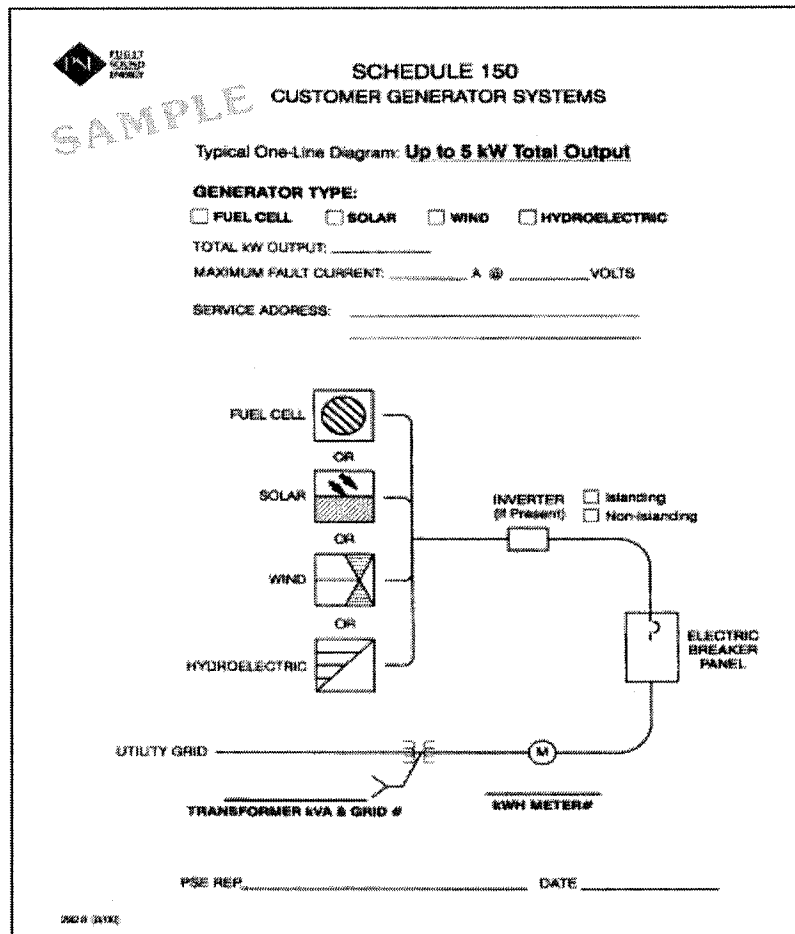

Issued: November 20, 2013
Effective: December 21, 2013
WN U-60 Attachment "E-2" to Schedule 80, Page 11

PUGET SOUND ENERGY

Attachment "E-2" Interconnection Agreement

Attachment "B" to INTERCONNECTION AGREEMENT (Continued)

Puget Sound Energy Standard 6325.4000

**Schedule 150 Net Metering for
Customer-Generator Systems**

6325.4000

One-Line Diagram (Systems 5 kW to 25 kW Output) Form 2929

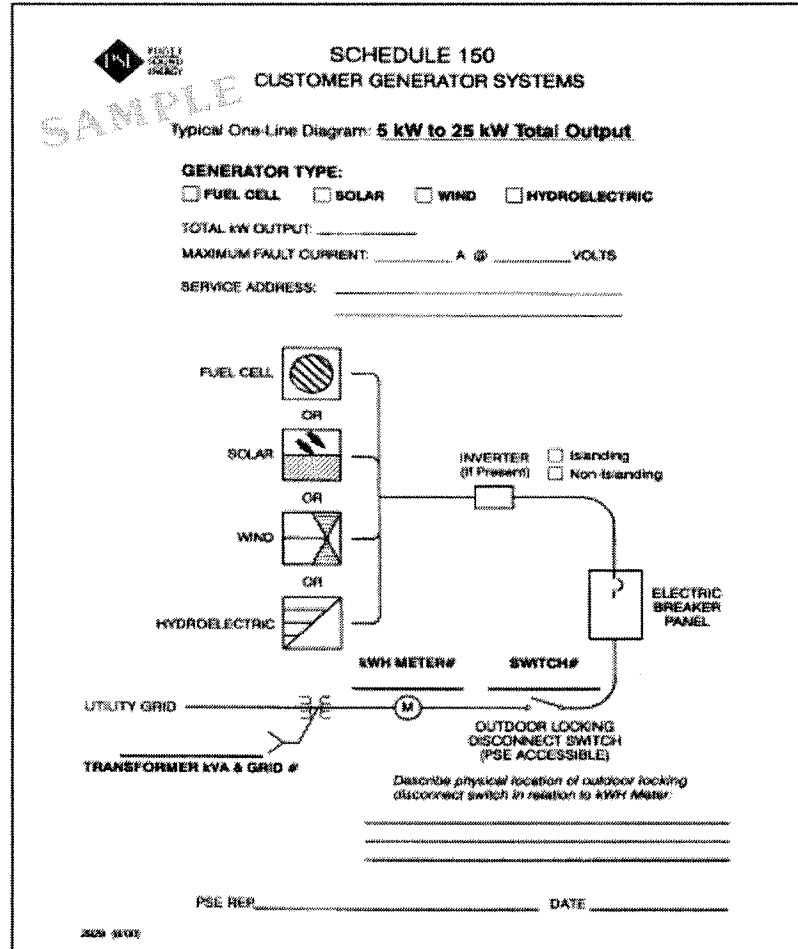

Issued: November 20, 2013

Effective: December 21, 2013

WN U-60

Attachment "E-2" to Schedule 80, Page 12

PUGET SOUND ENERGY

Attachment "E-2" Interconnection Agreement

Attachment "B" to INTERCONNECTION AGREEMENT (Continued)

Puget Sound Energy Standard 6325.4000

**Schedule 150 Net Metering for
Customer-Generator Systems**

6325.4000

References

The following Puget Sound Energy documents apply to this standard:

0650.2000 Standard Service Voltages
0650.4100 Voltage Flicker
0650.4200 Harmonics

Electric Schedule 150, Net Metering Services for Customer Generator Systems

Sources

WAC

296-45-335 De-energizing Lines and Equipment for Employee Protection