

TR-090252



Todd M. Kuhn, PE
Manager Public Projects

BNSF Railway Company
2454 Occidental Ave S Suite 1A
Seattle, WA 98134

206-625-6146
206-625-6115 (fax)
Todd.Kuhn@bnsf.com

March 31, 2009

Todd Boulanger
Senior Transportation Planner
City of Vancouver
P.O. Box 1995
Vancouver, WA 98668-1995

RECEIVED
2009 APR -6 PM 4:08
CITY OF VANCOUVER
TRANSPORTATION DEPARTMENT

RE: City of Vancouver, WA Notice of Intent for a New Quiet Zone

BNSF Railway is in receipt of the City of Vancouver's (City) Notice of Intent (NOI) dated January 30, 2009 to create a new quiet zone containing the following crossing:

USDOT #	CROSSING NAME
090072Y	Beach Drive (a.k.a. S.E. Columbia Way)

In accordance with FRA's Final Horn Rule ("Rule"), BNSF is writing this letter to comment on the proposed quiet zone. The following comments are based upon requirements set forth by FRA's train horn rule.

BNSF understands the City plans to install supplemental safety measures, (SSMs) in the form of mountable medians with reflective traffic channelization devices. Please refer to Appendix A of the Rule to satisfy requirements set forth for SSM installation and compliance. We have received information from the City that you may plan to use a "Type C Traffic Curb" (see Exhibit A) as supplied via email. Please note that BNSF is not aware that this measure, as the City plans to install with periodic breaks in the curbing and surface mounted delineators, will qualify as a SSM under the Rule. Please contact FRA so they may make this determination. The City will need to confer with FRA to make the determination of whether or not this measure is allowed under the Rule.

Upon completion of construction, please contact me to ensure all BNSF requirements for construction have been met. BNSF reserves the right to further comment as construction takes place. Once construction is complete, BNSF will require a written certification of completion from the City. Once this is received by BNSF, and all other requirements are met, the City may issue the Notice of Establishment for the quiet zone implementation.

Please feel free to call me with any questions.

Regards,

Todd M. Kuhn

cc: FRA Associate Administrator
1200 New Jersey Ave, SE
Washington, DC 20590

Ahmer Nizam
WSDOT
P.O. Box 47329
Olympia, WA 98504-7329

Katherine Hunter
WUTC
1300 S. Evergreen Park Dr. SW
P.O. Box 47250
Olympia, WA 98504-7250

Kurt Laird
Amtrak Sr Safety Coordinator
1875 South Holgate St
Seattle, WA 98134

cc via electronic mail:

John Shurson, BNSF RR
Lyn Hartley, BNSF RR
Ryan Ringelman, BNSF RR
Nicole Hightower, BNSF RR

Type 'C' Traffic Curb

WSDOT Standard Plan F-2

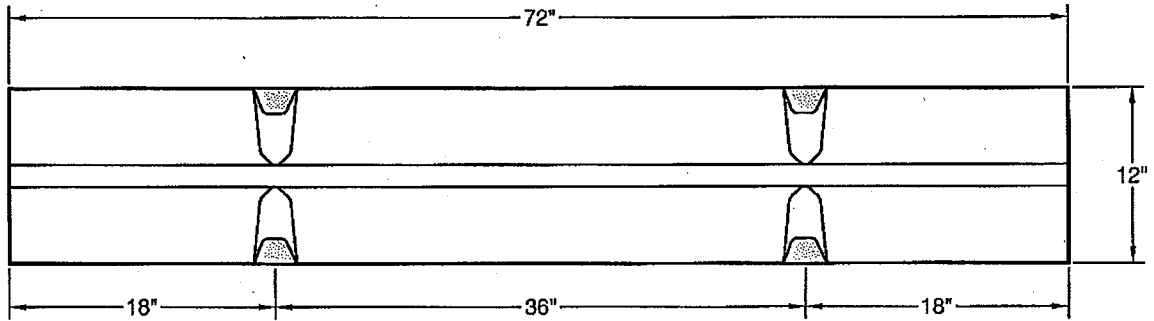

PLAN

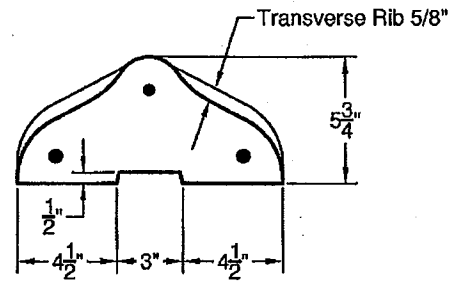
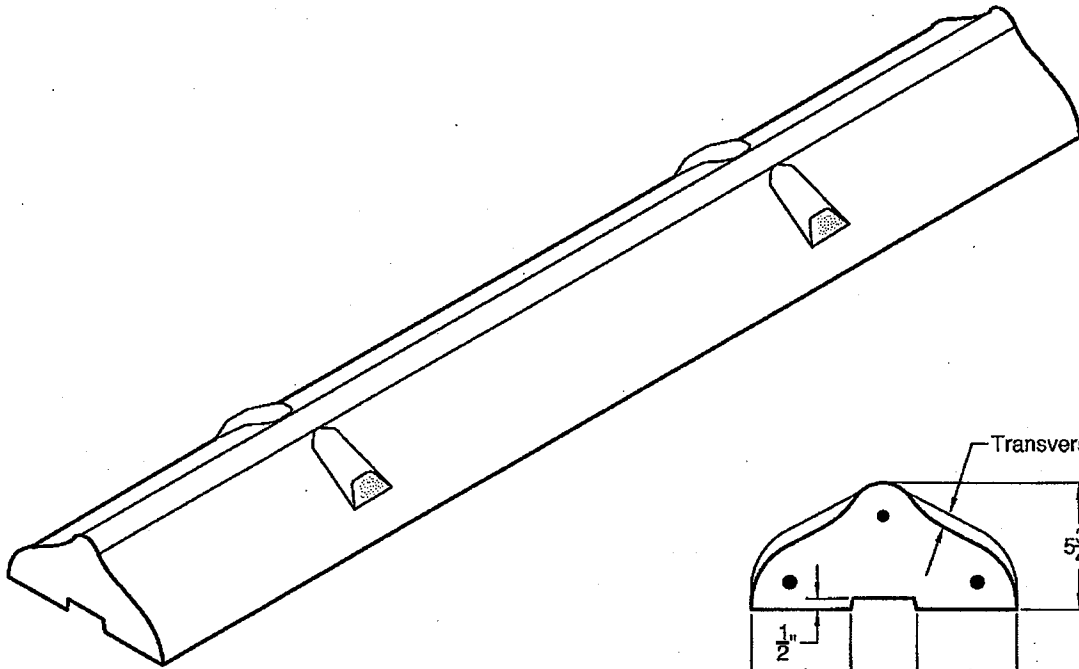

SECTION

Weight: 260 lbs
Concrete: Fc= 4,000 psi @ 28 Days
Reinforcement: (3) - #3 Rebar
ASTM A-615 Grade 60

333



GRANITE

PRECASTING & CONCRETE INC.

4116 BAKERVIEW SPUR • BELLINGHAM, WA 98226 • (360) 671-2251 • 1-800-808-2251 • FAX: (360) 671-0780