

Exh. RAV-2
Docket UE-21 _____
Witness: Richard A. Vail

**BEFORE THE WASHINGTON
UTILITIES AND TRANSPORTATION COMMISSION**

WASHINGTON UTILITIES AND
TRANSPORTATION COMMISSION,

Complainant,

v.

PACIFICORP dba
PACIFIC POWER & LIGHT COMPANY

Respondent.

Docket UE-21 _____

PACIFICORP

EXHIBIT OF RICHARD A. VAIL

Energy Vision 2020 Wind Network Improvements

July 2021

Energy Vision 2020 Wind Network Improvements

D.2 Project Facilities:

D.2 Project Transmission Facilities:

- Addition of the Aeolus 500/230 kV autotransformer
- Addition of the Aeolus – Anticline 500 kV line (~138 miles)
- Addition of the Anticline 500/345 kV autotransformer
- Addition of the Anticline – Bridger 345 kV line (5 miles)

Southeast Wyoming – Network Upgrades

- Loop the Shirley Basin – Freezeout 230 kV line into Aeolus 230 kV
- Add the Aeolus – Shirley Basin 230 kV #2 line (~16 miles) [Q0707]
- Rebuild the Aeolus – Shirley Basin 230 kV #1 line (~16 miles) [Q0712]
- Rebuild the Aeolus – Freezeout - Standpipe 230 kV line (~15 miles) [Q0712]
- Add Latham SVC

A drawing depicting all new D.2 Project network transmission facilities east of Jim Bridger Power Plant is provided below:

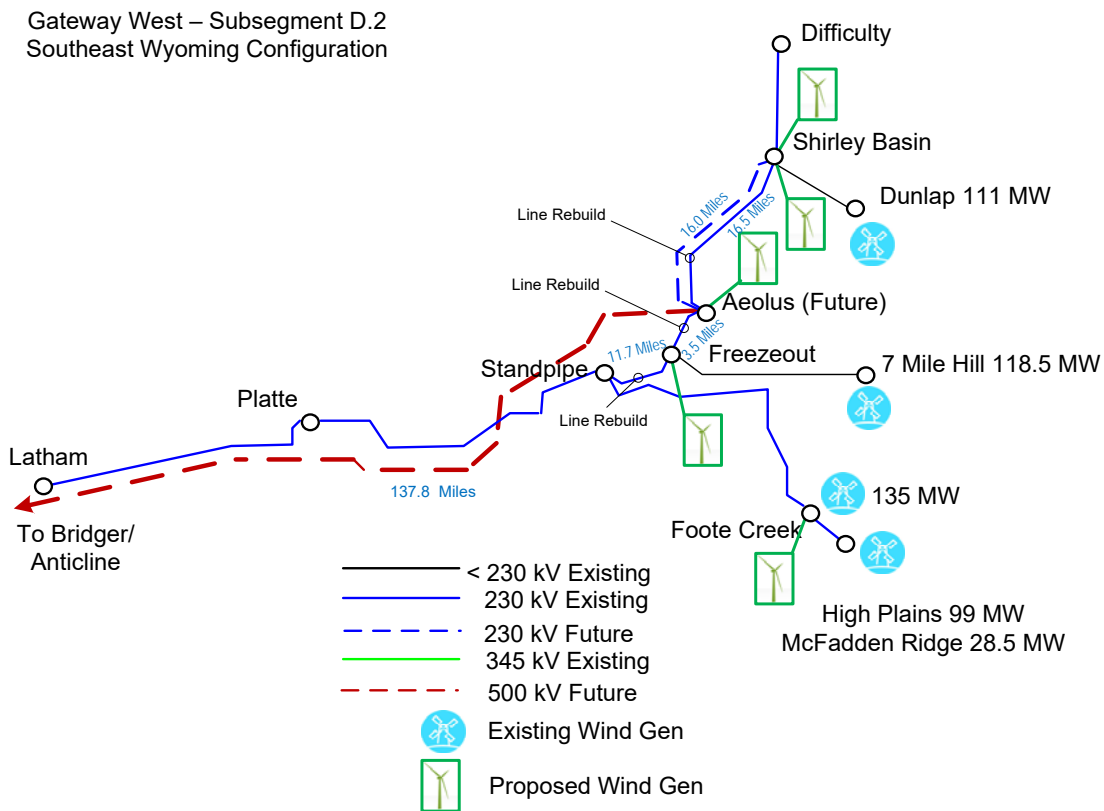

At the Aeolus substation to support the Ekola Flats wind project the following network upgrades are required:

- Add one (1) 230 kV 4000 ampere circuit breaker and one line position with associated switches.
- Include the project in the Aeolus RAS generation dropping scheme.

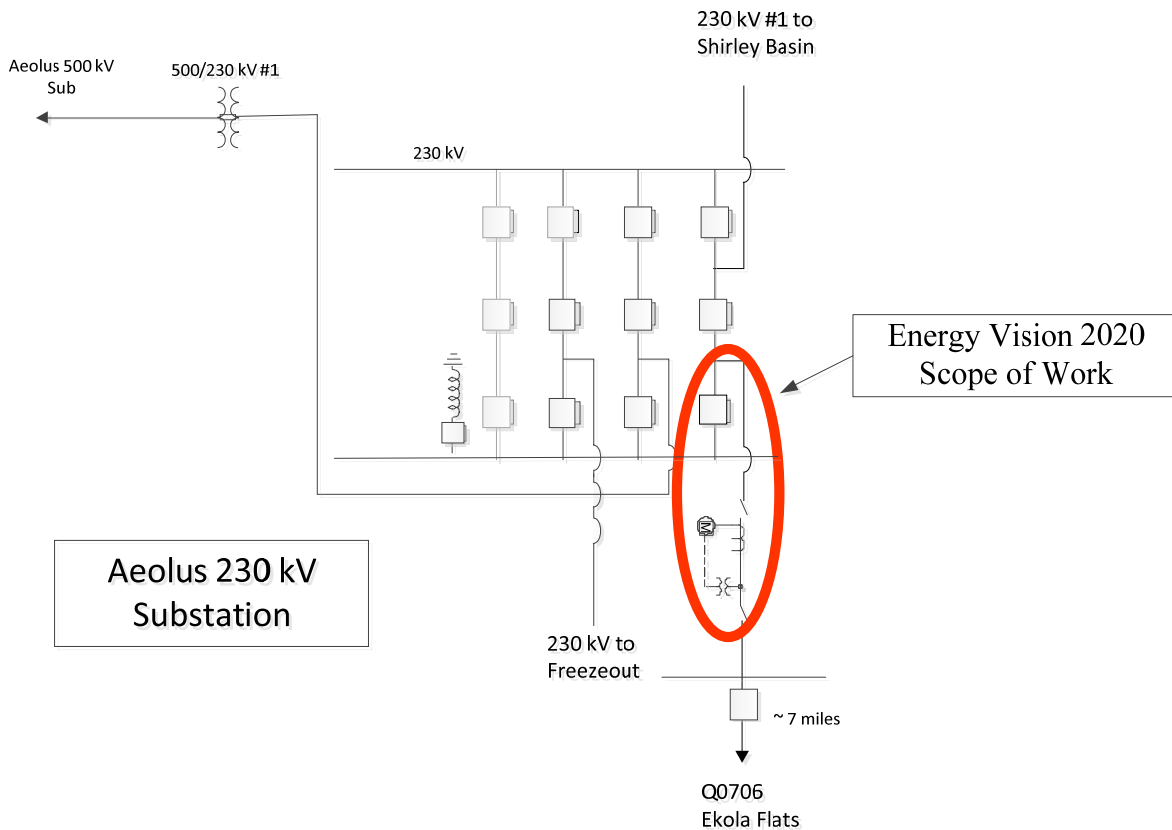

At Shirley Basin substation to support the inclusion of TB Flats I wind projects, the following network upgrades are required:

- Add one new bay and rebuild existing bays to 4000 amperes, seven (7) new 4000 ampere 230 kV circuit breakers, two line terminations with associated switches
- Construct a new approximately 16.5-mile Shirley Basin – Aeolus 230 kV #2 line.

At Aeolus substation the following network improvements are required:

- Add one (1) new 4000 ampere 230 kV circuit breaker, one line termination and associated switches
- Include the project in the Aeolus RAS generation dropping scheme.

The TB Flats I and II were combined into a single point of interconnection. As such, to support inclusion of the TB Flats II wind the following network upgrades are required:

- Include the project in the Aeolus RAS generation dropping scheme.

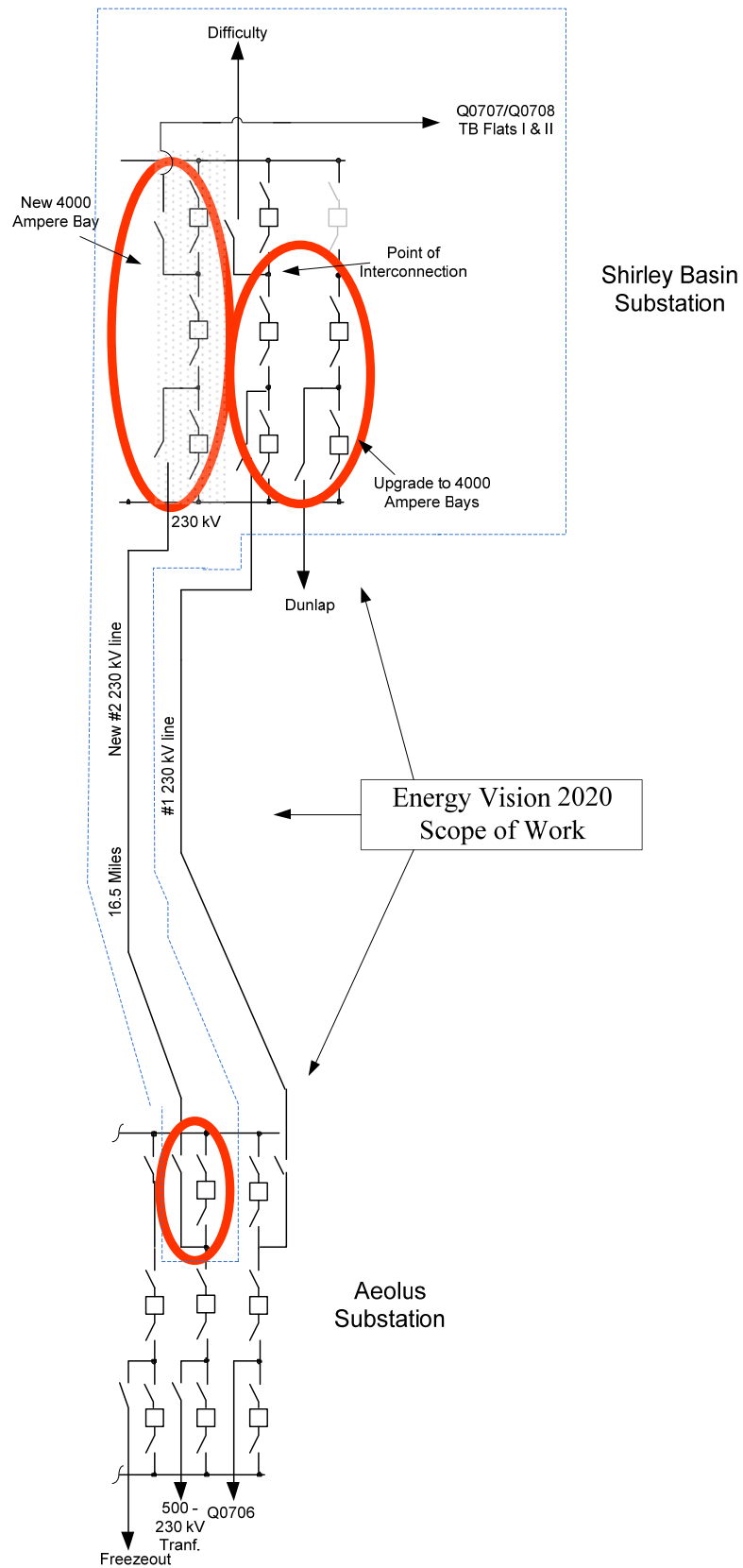

At Windstar substation to support the inclusion of Cedar Springs I wind project the following network upgrades are required:

- Add one (1) 230 kV 3000 ampere circuit breakers and one line termination

At Freezeout substation to support the inclusion of Cedar Springs I wind project the following network upgrades are required:

- Add three (3) 230 kV 4000 ampere circuit breakers along with associated switches for re-termination of lines associated with the Aeolus-Freezeout-Standpipe 230 kV line rebuild
- Upgrade two bays to 4000 amperes
- Rebuild the Aeolus – Freezeout – Standpipe 230 kV line ~15 miles
- Rebuild the Shirley Basin – Aeolus 230 kV #1 line ~16 miles

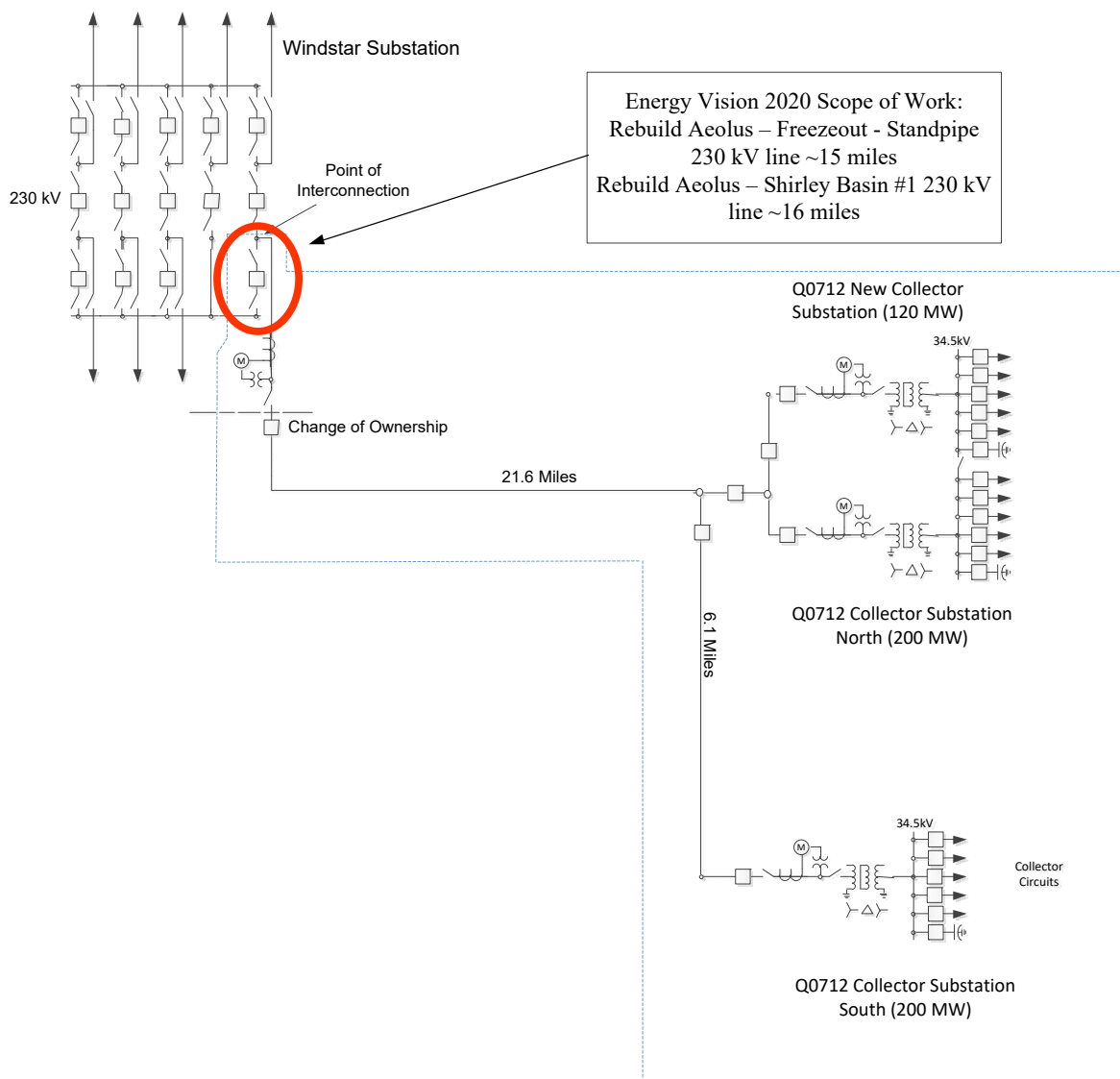

Freezeout 230 kV

