

**EXHIBIT NO. \_\_\_(GZ-3)**  
**DOCKET NO. UE-051828/UE-051966**  
**WITNESS: GREG ZELLER**

**BEFORE THE  
WASHINGTON UTILITIES AND TRANSPORTATION COMMISSION**

**WESTERN VILLAGE, LLC, D/B/A  
WESTERN VILLAGE ESTATES,**

**Complainant,**

**v.**

**PUGET SOUND ENERGY, INC.**

**Respondent.**

**Docket No. UE-051828**

**WASHINGTON UTILITIES AND  
TRANSPORTATION COMMISSION,**

**Complainant,**

**v.**

**PUGET SOUND ENERGY, INC.,**

**Respondent.**

**Docket No. UE-051966**

**SECOND EXHIBIT TO THE PREFILED DIRECT TESTIMONY OF  
GREG ZELLER, P.E.  
ON BEHALF OF PUGET SOUND ENERGY, INC.**

**MARCH 8, 2006**

---

# Typical Mobile Home/Manufactured Home Park

## Plan View

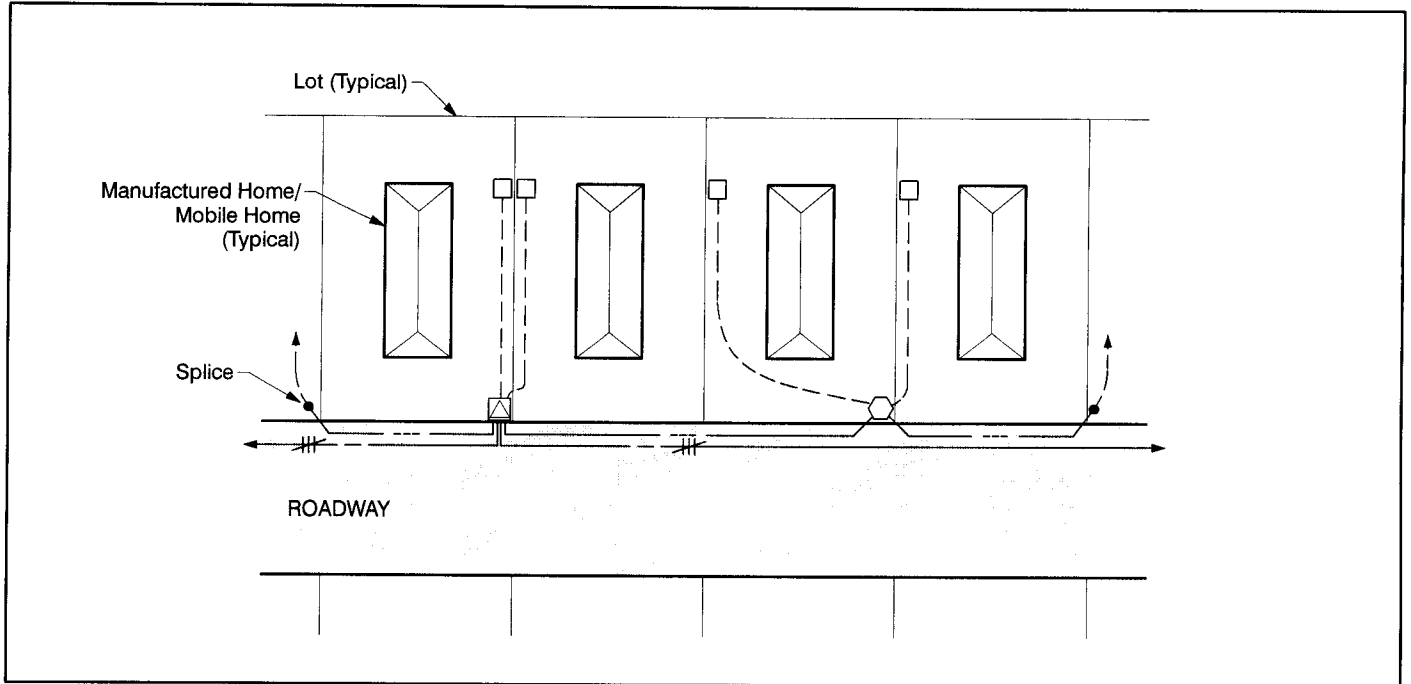

- Transformer
- Handhole
- Customer-Owned Service Cable
- Customer-Owned Meter Pedestal
- / / /
 PSE Primary Voltage Cable
- PSE Secondary Service Cable

# Typical Mobile Home/Manufactured Home Park

## Side View

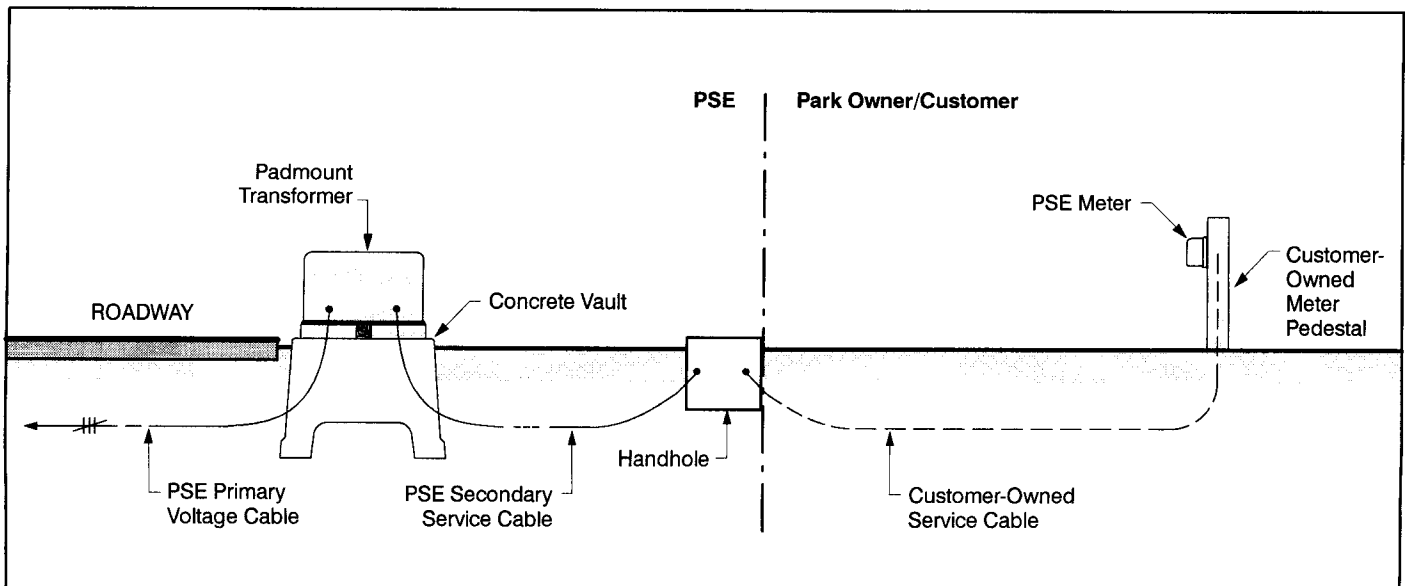

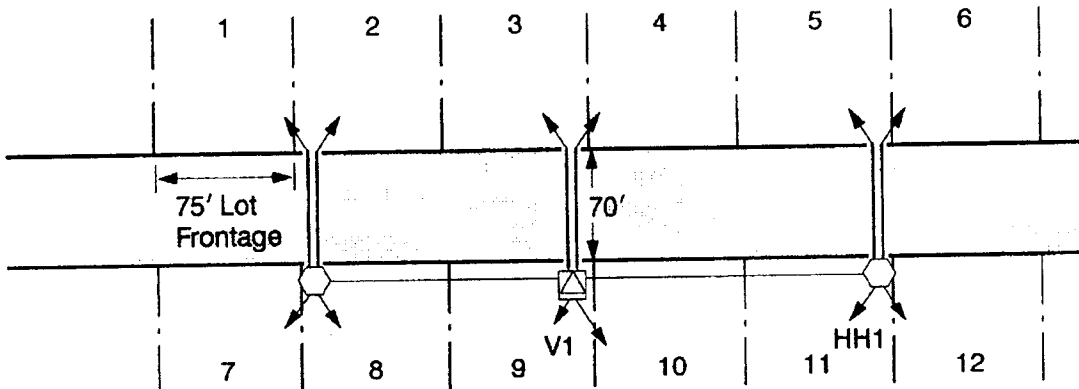

→ Service to Home

— Secondary Conductor

▣ Transformer

⬡ Handhole

HH1 = Handhole No. 1

V1 = Vault No. 1