

BEFORE THE WASHINGTON UTILITIES AND TRANSPORTATION COMMISSION

ALCOA,

Petitioner

.....)

)
)
) DOCKET NO. TR-980783
)
)

) ORDER GRANTING PETITION
) FOR WAIVER OF CLEARANCE RULES
)
)

By petition filed with the Commission on March 6, 1998, ALCOA requests the commission to waive side and height clearance rules for a tank car unloading mechanism located on tracks owned by the Burlington Northern and Santa Fe Railway Company at the ALCOA plant located in Malaga, Washington.

ALCOA unloads tank cars at its plant in Malaga. Currently tank cars are unloaded from underneath the car. ALCOA proposes to construct automatic unloading arms which will unload tank cars from the top. In their folded up positions the unloading arms would be 6 feet from the center line of the track and 13 feet 6 inches above the tracks. Current rules require a side clearance of 8 feet 6 inches, and a height clearance of approximately 20 feet.

The Burlington Northern and Santa Fe Railway Company has reviewed the plans submitted by petitioner and has no objection to the proposed position of the automatic unloading device. Its letter stating that it has no objection is on file herein.

Staff has investigated the request. Staff found that the requested waiver is needed to complete construction of the automatic unloader, that the position of the unloading arm is so high that it is unlikely to create a substantial hazard, and the new unloading procedure creates fewer hazards to rail employees than current procedures; however, a sign warning of the reduced clearances should be placed as proposed in the plans.

The Commissioners, having reviewed the petition and being fully advised in the matter, believe that granting the petition, subject to the conditions set forth below, is essential to the provision of new unloading arms at the ALCOA site in Malaga, does not violate the public interest, and does not increase danger to any persons

368

ORDER

THE COMMISSION ORDERS that the petition of ALCOA for a waiver of clearance rules shall be, and the same is hereby, granted on the condition that construction and operation be as set forth in the plans and specifications provided in the application and attached to this order as Annex A.

IT IS FURTHER ORDERED that petitioner must inform the commission within one week after all construction has been completed.

DATED at Olympia, Washington, and effective this 15th day of June, 1998.

WASHINGTON UTILITIES AND TRANSPORTATION COMMISSION

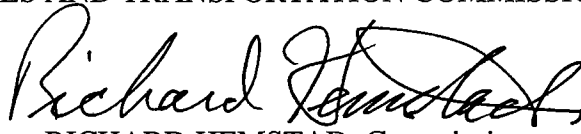
RICHARD HEMSTAD, Commissioner

WILLIAM R. GILLIS, Commissioner

SKO3A

EXISTING 3" VENT LINE

4" UNLOADING LINE

388-P002
FIELD PLAN
AREA

FOLDED

PLTFM

CLEARANCE LINE

SLOPE

4'-0"

2'-6"

8'-6"

11'-0"

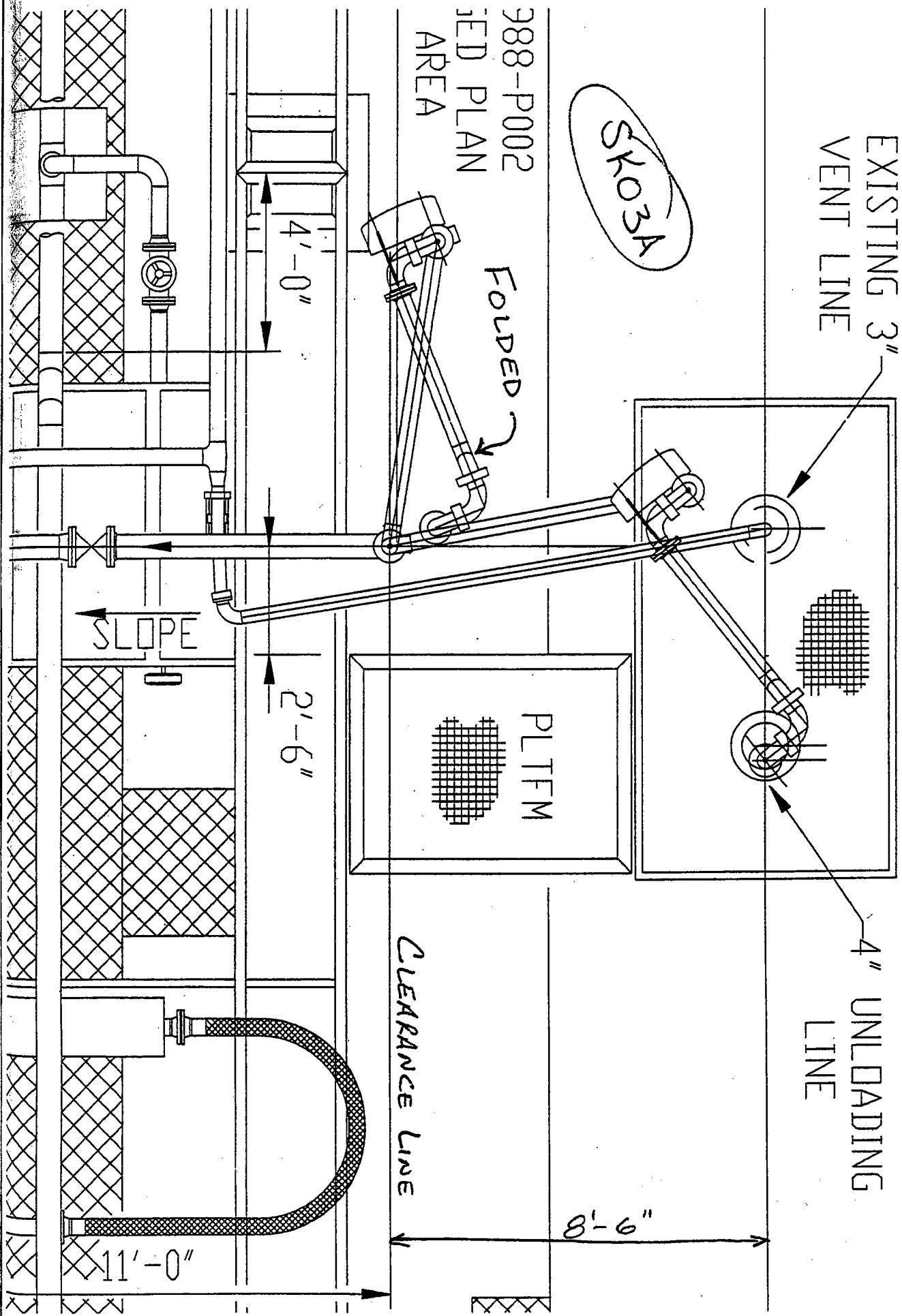

SK03B

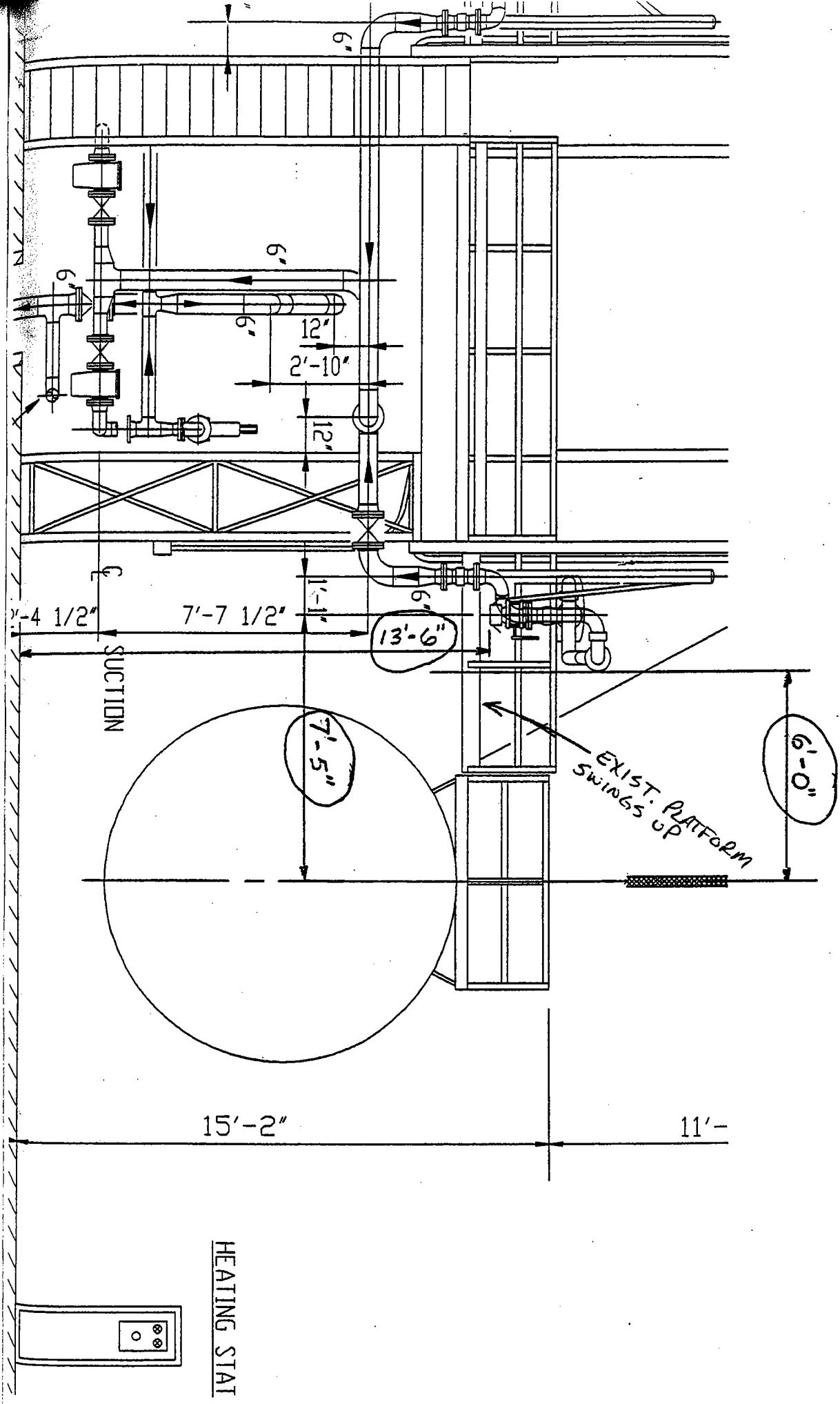

WARNING

RESTRICTED CLEARANCE

DO NOT RIDE ON RAILCARS