

WN U-16
Frontier Communications Northwest, LLC d/b/a Ziplly Fiber

Original Title Sheet 1

FACILITIES FOR INTRASTATE ACCESS

TARIFF

OF

Frontier Communications Northwest, LLC
d/b/a Ziplly Fiber

135 Lake Street South
Kirkland, Washington 98033

SERVICES PROVIDED IN THIS TARIFF
are available to all
Wholesale and Retail customers

This Schedule of Rates, Rules, and Regulations is
Applicable to Facilities for Intrastate Access
In the Territory Served by the Company
Within the State of Washington

Issued: July 29, 2020
Issued by Ziplly Fiber
By Jessica Epley, Regulatory & External Affairs Director

Effective: July 31, 2020

WN U-16
Zipty Fiber

Original Sheet 2

FACILITIES FOR INTRASTATE ACCESS

TABLE OF CONTENTS
ALPHABETICAL LISTING

	<u>Section</u>
Application of Tariff	1
Carrier Common Line Service	11
Coin Services	14
Exceptions to FIA Offerings	12
General Regulations	2
Miscellaneous Services	6
Operator Services	13
Ordering Options for FIA	3
Promotions	10
Rate Zone Wire Centers	15
Special Access	5
Special Construction	9
Special Facilities Routing of FIA	8
Specialized FIA or Arrangements	7
Switched Access	4

Issued: July 29, 2020
Issued by Zipty Fiber
By Jessica Epley, Regulatory & External Affairs Director

Effective: July 31, 2020

WN U-16
Zipty Fiber

Original Sheet 3

FACILITIES FOR INTRASTATE ACCESS

TABLE OF CONTENTS	<u>Sheet No.</u>
Table of Contents	2
Explanation of Symbols	32
Explanation of Abbreviations	32
Reference to Other Tariffs	36
Reference to Technical Publications	36
Concurrences	37
1. <u>APPLICATION OF TARIFF</u>	38
2. <u>GENERAL REGULATIONS</u>	39
2.1 <u>Undertaking of the Telephone Company</u>	41
2.1.1 Scope	41
2.1.2 Limitations	41
2.1.3 Liability	43
2.1.4 Provision of FIA	44
2.1.5 Installation and Termination of FIA.....	44
2.1.6 Maintenance of FIA.....	44
2.1.7 Changes and Substitutions	45
2.1.8 Discontinuance and Refusal of FIA	45
2.1.9 Preemption of FIA.....	46
2.1.10 Limitation of Use of Metallic Facilities	47
2.2 <u>Use</u>	48
2.2.1 Interference or Impairment.....	48
2.2.2 Unlawful Use of FIA	48

WN U-16
ZiPLY Fiber

Original Sheet 4

FACILITIES FOR INTRASTATE ACCESS

TABLE OF CONTENTS	<u>Sheet No.</u>
2. <u>GENERAL REGULATIONS (Cont'd)</u>	
2.3 <u>Obligation of the Customer</u>	49
2.3.1 Damages	49
2.3.2 Theft	50
2.3.3 Equipment Space and Power	50
2.3.4 Availability for Testing	50
2.3.5 Balance	50
2.3.6 Design of Customer Services	50
2.3.7 Reserved For Future Use	51
2.3.8 Reserved For Future Use	51
2.3.9 References to Telephone Company	51
2.3.10 Claims and Demands for Damages	51
2.3.11 Coordination With Respect to Network Contingencies	51
2.3.12 Identification and Rating of VoIP-PSTN Traffic	51.1
2.4 <u>Payment Arrangements and Credit Allowances</u>	52
2.4.1 Payment of Charges and Deposits	52
2.4.2 Minimum Periods	56
2.4.3 Cancellation of an ASR	57
2.4.4 Credit Allowance for FIA Interruptions	58
2.5 <u>Connections</u>	61
2.6 <u>Definitions</u>	62
2.7 <u>FIA Services Provided By More Than One Telephone Company</u>	87
2.7.1 General	87
2.7.2 Single Company Billing	87
2.7.3 Meet Point Billing	88
2.7.4 Zone Density meet Point Billing	94
2.8 <u>Termination Liability</u>	95
2.8.1 General	95
2.8.2 Early Termination Charges	95
2.8.3 End of Term Options	95
2.8.4 Early Termination Liability	96
2.8.5 Termination Applicability	96

WN U-16
Zipty Fiber

Original Sheet 5

FACILITIES FOR INTRASTATE ACCESS

TABLE OF CONTENTS	<u>Sheet No.</u>
3. <u>ORDERING OPTIONS FOR FIA</u>	97
3.1 <u>General</u>	98
3.1.1 Ordering Conditions	98
3.1.2 Provision of Other Services	105
3.1.3 Special Construction	105
3.1.4 Tandem Switch Signaling	105
3.2 <u>Access Service Request</u>	106
3.2.1 Service Date Intervals	106
3.2.2 ASR Modifications	106
(A) Service Date Change Charge	107
(B) Partial Cancellation Charge	107
(C) Discontinuance of Service	108
(D) Design Change Charge	108
(E) Expedited Order Charge	108
3.2.3 Selection of Facilities for Access Service	109
3.2.4 Minimum Period	109
3.2.5 Minimum Period Charges	110
3.2.6 Cancellation of an ASR	111
3.2.7 Discontinuance of Switched Access FGD or BSA-D	114
3.2.8 FGD pr BSA-D Maximum Per Trunk Cancellation Charge	114
3.3 <u>Access Service Requests For Services Provided By More Than One Telephone Company</u>	115

WN U-16
Zipty Fiber

Original Sheet 6

FACILITIES FOR INTRASTATE ACCESS

TABLE OF CONTENTS	<u>Sheet No.</u>
4. <u>SWITCHED ACCESS</u>	116
4.1 <u>General</u>	124
4.2 <u>Description of Switched Access</u>	125
4.2.1 <u>Description of Feature Groups</u>	126
(A) <u>Feature Group A</u>	126
(B) <u>Feature Group B</u>	130
(C) <u>Feature Group C</u>	134
(D) <u>Feature Group D</u>	139
(E) <u>SAC Access Service</u>	145
4.2.2 <u>Description of Basic Serving Arrangements (BSAs)</u>	148
(A) <u>BSA-A</u>	148
(B) <u>BSA-B</u>	153
(C) <u>BSA-C</u>	158
(D) <u>BSA-D</u>	164
(E) <u>Dedicated Network Access Line (DNAL)</u>	170
4.2.3 <u>Description of Switched Transport</u>	171
(A) <u>General</u>	171
(B) <u>Entrance Facilities</u>	174
(1) <u>Two-Wire Voice Frequency Entrance Facility</u>	174
(2) <u>Four-Wire Voice Frequency Entrance Facility</u>	175
(3) <u>Group Analog Entrance Facility</u>	176
(4) <u>Supergroup Analog Entrance Facility</u>	176
(5) <u>Mastergroup Analog Entrance Facility</u>	177
(6) <u>DS1 Digital Entrance Facility</u>	177
(7) <u>DS1C Digital Entrance Facility</u>	178
(8) <u>DS2 Digital Entrance Facility</u>	178
(9) <u>DS3 Digital Entrance Facility</u>	178
(10) <u>DS3C Digital Entrance Facility</u>	179

WN U-16
Zipty Fiber

Original Sheet 7

FACILITIES FOR INTRASTATE ACCESS

TABLE OF CONTENTS	<u>Sheet No.</u>
4. <u>SWITCHED ACCESS</u> (Cont'd)	
4.2 <u>Description of Switched Access</u> (Cont'd)	
4.2.3 <u>Description of Switched Transport</u> (Cont'd)	
(C) Direct Trunked Transport	180
(D) Tandem-Switched Transport	181
(E) Interconnection Rate	181
(F) Multiplexing Arrangement	182
(G) Optional Arrangements	182
4.2.4 <u>Description of End Office Services</u>	184
4.2.5 <u>End Office Services Optional Arrangements</u>	185
(A) Alternate Traffic Routing	185
(B) Automatic Number Identification (ANI) Arrangement	186
(C) Intra Access Area Call Denial on Line or Hunt Group	188
(D) InterLATA Call Denial on Line or Hunt Group	189
(E) Call Denial on Line or Hunt Group Outside of the Access Area.....	189
(F) Dual Tone Multifrequency Address Signaling	190
(G) Hunt Group Arrangement.....	190
(H) Customer Specification of Switched Access Directionality	190
(I) Nonhunting Number for Use with Hunt Group Arrangement.....	190
(J) Nonhunting Number for Use with Uniform Call Distribution Arrangement	191
(K) Operator Assistance Full Feature Arrangement.....	191
(L) Rotary Dial Station Signaling	191
(M) Service Class Routing.....	191
(N) Service Code Denial on Line or Hunt Group.....	192

FACILITIES FOR INTRASTATE ACCESS

TABLE OF CONTENTS

Sheet No.

4.	<u>SWITCHED ACCESS</u> (Cont'd)	
4.2	<u>Description of Switched Access</u> (Cont'd)	
4.2.5	End Office Services Optional Arrangements (Cont'd)	
(O)	Trunk Access Limitation	192
(P)	Uniform Call Distribution Arrangement	192
(Q)	Up to Seven Digit Outpulsing of Access Digits to the Customer.	192
(R)	Band Advance Arrangement	192
(S)	FGD and BSA-D Switched Access with 950-XXXX Access	193
(T)	Operator Assistance for SAC Access Services	193
(U)	Switched Access Interface	193
(V)	Switched Data Service	201
(1)	Switched 56	201
(2)	Switched 64	201
(W)	Signaling System 7 (SS7) Out of Band Signaling	202
(X)	Calling Party Number (CPN) Parameter	202
(Y)	Carrier Selection Parameter (CSP)	202
(Z)	Charge Number (CN) Parameter	203
(A)(A)	Tandem Switch Signaling	204
(A)(B)	Carrier Identification Parameter (CIP)	204
4.2.6	Call Restriction and Code Screening Reports	205
4.2.7	Installation and Acceptance Testing of Switched Access	205
4.2.8	Provision of Design Layout Report	205
4.2.9	Network Management	206
4.2.10	800/877/888 Customer Identification Function	206
4.2.11	900 Customer Identification Function	206

WN U-16
Zipty Fiber

Original Sheet 9

FACILITIES FOR INTRASTATE ACCESS

TABLE OF CONTENTS	<u>Sheet No.</u>
4. <u>SWITCHED ACCESS</u> (Cont'd)	
4.2 <u>Description of Switched Access</u> (Cont'd)	
4.2.12 Design and Routing of Switched Access	206
4.2.13 Provision of Switched Access Performance Data	207
4.2.14 Transmission Performance	207
4.2.15 Design Blocking Probability.....	207
4.2.16 Special Facilities Routing.....	210
4.2.17 Information Surcharge	210
4.2.18 800/877/888 Data Base Query Service	210
4.2.19 500 Customer Identification Function	210
4.2.20 Tandem Switch Signaling.....	210
4.2.21 Basic Service Elements (BSEs)	211
4.2.22 IntraLATA Equal Access Recovery Charge	219
4.3 <u>Obligations of the Customer</u>	220
4.3.1 On and Off-Hook Supervision	220
4.3.2 ASR Requirements	220
4.3.3 Jurisdictional Report Requirements.....	221
(A) Jurisdictional Reports	221
(B) Maintenance of Customer Records	226
(C) Jurisdictional Reports Verification.....	227
(D) Contested Jurisdictional Reports	228
4.4 <u>Payment Arrangements and Credit Allowances</u>	231
4.4.1 Cancellation of Applications	231
4.4.2 Credit Allowances	231

WN U-16
ZiPLY Fiber

Original Sheet 10

FACILITIES FOR INTRASTATE ACCESS

TABLE OF CONTENTS	<u>Sheet No.</u>
4. <u>SWITCHED ACCESS</u> (Cont'd)	
4.5 <u>Rate and Charge Regulations</u>	231
4.5.1 Rate Elements	231
4.5.2 Rate Regulations	232
(A) Types of Rates and Charges.....	232
(1) Usage Rates.....	232
(2) Flat Rated	232
(3) Nonrecurring Charges.....	233
(a) Service Installation Charges	233
(b) Installation of Voiceband Entrance Facilities.....	233
(c) Installation of Multiplexing Arrangements	233
(d) Installation of DS1 and DS3 Entrance Facilities	233
(1) DS1 Standard Arrangements	233
(2) DS1 Optional Payment Plan (OPP) Arrangement	234
(3) DS3 Arrangements	234
(e) Switched Access Installation Charge Waiver	235
(f) Switched Access Ordering Charges	235
(g) Service Rearrangements	237
(h) Design Change Charge.....	246
(i) Installation Charge for FGA and BSA-A Optional Toll	
Blocking Arrangements	246
(j) Change of Switched Access Type	247
(k) Moves.....	250
(1) Same CDL.....	250
(2) A Different CDL	250
(B) 800/877/888 Data Base Query Service	250

WN U-16
ZiPLY Fiber

Original Sheet 11

FACILITIES FOR INTRASTATE ACCESS

TABLE OF CONTENTS	<u>Sheet No.</u>
4. <u>SWITCHED ACCESS</u> (Cont'd)	
4.5 <u>Rate and Charge Regulations</u> (Cont'd)	
4.5.2 Rate Regulations (Cont'd)	
(C) Network Blocking Charge for Tandem Switched FGB, FGC, FGD, BSA-B, BSA-C, BSA-D and SAC Access Service	251
(D) Determination of Intrastate Charges for Mixed Interstate and Intrastate Switched Access	252
(E) Local Dial-It Services	252
(F) Local Directory Assistance	252
(G) Signaling System 7 (SS7) Out of Band Signaling	252
(H) Description and Application of Rates	253
(1) Determination of Premium Rates and Nonpremium Rates .	253
(2) Switched Transport	254
(3) Extended FGA and BSA-A Terminating Traffic	259
(4) Equal Access Notification	260
(5) End Office Switching	262
(6) Transitional Billing Arrangements	262
(7) Tandem Switch Signaling (TSS)	265
(8) NXX Translation Nonrecurring Charge	266
(I) Measuring Access Minutes	267
(1) FGA and BSA-A Usage Measurement	268
(2) FGB and BSA-B Usage Measurement	269
(3) Usage Measurement Not Available For FGA, FGB, BSA-A and BSA-B	269
(4) FGC and BSA-C Usage Measurement	270
(5) FGD and BSA-D Usage Measurement	272
(6) SAC Access Service Usage Measurement	273
(J) FGD and BSA-D Switched Access Service with 950-XXXX	273
4.5.3 Switched Access Zone Density Rate Plan	273
4.5.4 Application of Rates for FGA and BSA-A Extension Service	275

WN U-16
Zipty Fiber

Original Sheet 12

FACILITIES FOR INTRASTATE ACCESS

TABLE OF CONTENTS	<u>Sheet No.</u>
4. <u>SWITCHED ACCESS</u> (Cont'd)	
4.5 <u>Rate and Charge Regulations</u> (Cont'd)	
4.5.5 Switched Access DS1 Optional Payment Plan (OPP).....	276
4.5.6 Switched Access DS1 Term Payment Plan	281
4.5.7 Switched Access DS3 Term Payment Plan	286
4.5.8 Shared Use Analog and Digital High Capacity Services	292
4.5.9 Basic Service Elements (BSEs)	293
(A) Alternate Traffic Routing - BSE	293
(B) Automatic Number Identification (ANI) - BSE	293
(C) User Transfer - BSE.....	293
(D) Hunt Group Arrangement - BSE	293
(E) Queuing - BSE.....	293
(F) Uniform Call Distribution - BSE	294
(G) Simplified Message Desk Interface (SMDI) - BSE	294
(H) Remote Call Forwarding - BSE	294
(I) Direct Inward Dialing (DID) - BSE	294
(J) Billing Number Screening (BNS) - BSE	294

WN U-16
Zipty Fiber

Original Sheet 13

FACILITIES FOR INTRASTATE ACCESS

TABLE OF CONTENTS	<u>Sheet No.</u>
4. <u>SWITCHED ACCESS</u> (Cont'd)	
4.6 <u>Rates and Charges</u>	295
4.6.1 Nonrecurring Charges	295
(A) Switched Access Service Ordering Charges	295
(B) 500 NXX Translation Charge	295
(C) Network Blocking Charge	295
(D) FGA and BSA-A Optional Toll Blocking	295
4.6.2 Switched Transport	296
(A) Tandem-Switched Transport - Facility	296
(B) Tandem-Switched Transport - Termination	296
(C) Tandem Switching Rate	296
(D) Direct-Trunked Transport-Voiceband	297
(E) Direct-Trunked Transport - DS1	297
(F) Direct-Trunked Transport - DS3	297
(G) Entrance Facility - 2-Wire and 4-Wire Voiceband	298
(H) Entrance Facility - DS1	298
(I) Entrance Facility - DS3	299
(J) Multiplexing	299
(K) Entrance Facility - DS1 - Optional Payment Plan (Discounted Rate)	300
(L) Entrance Facility - DS1 - Term Payment Plan (Discounted Rate)	301
(M) Entrance Facility - DS3 - Term Payment Plan (Discounted Rate)	302
(N) Interconnection Rate, Per Access Minute	302

WN U-16
ZiPLY Fiber

Original Sheet 14

FACILITIES FOR INTRASTATE ACCESS

TABLE OF CONTENTS

Sheet No.

4. SWITCHED ACCESS (Cont'd)

 4.6 Rates and Charges (Cont'd)

 4.6.3 End Office Services 307

 (A) End Office Switching - Bundled (EOSB)..... 307

 (B) End Office Switching - Unbundled (EOSU)..... 307

 (C) Alternate Routing - BSE 307

 (D) Automatic Number Identification (ANI) - BSE 308

 (E) User Transfer - BSE..... 308

 (F) Queuing - BSE..... 308

 (G) Uniform Call Distribution - BSE 308

 (H) Simplified Message Desk Interface (SMDI) - BSE 308

 4.6.4 Information Surcharge 309

 4.6.5 IntraLATA Equal Access Recovery Charge 309

 4.6.6 Line Extension Rate Additive 309

FACILITIES FOR INTRASTATE ACCESS

TABLE OF CONTENTS	<u>Sheet No.</u>
5. <u>SPECIAL ACCESS</u>	310
5.1 <u>General</u>	318
5.1.1 Rate Elements	318
(A) Special Transport	320
(B) Special Access Line (SAL)	321
(C) Supplemental Features	323
(D) Multiplexing Arrangements	323
(E) Special Transport Termination	323
(1) DS1, DS1C and DS3 Service	323
(2) Fractional T1 Service (FT1)	323
5.1.2 Special Access Configurations	324
(A) Two-point Service	324
(B) Multipoint Service	326
5.1.3 Special Facilities Routing	328
5.1.4 Design Layout Report	328
5.1.5 Acceptance Testing	329
5.1.6 Ordering Conditions	330
(A) Determination of Jurisdiction of Mixed Use Special Access Service	330
(B) Special Access Jurisdictional Verification	330
5.2 <u>Description of Special Access</u>	331
5.2.1 Voiceband	332
(A) Two-Wire Voiceband Facility	332
(B) Four-Wire Voiceband Facility	332
5.2.2 Program Audio	332
(A) 200 to 3500 Hz	333
(B) 100 to 5000 Hz	333
(C) 50 to 8000 Hz	333
(D) 50 to 15000 Hz	333

FACILITIES FOR INTRASTATE ACCESS

TABLE OF CONTENTS	<u>Sheet No.</u>
5. <u>SPECIAL ACCESS</u> (Cont'd)	
5.2 <u>Description of Special Access</u> (Cont'd)	
5.2.3 Videoband	334
5.2.4 Wideband Analog	335
5.2.5 Wideband Data Service	336
5.2.6 High Capacity Digital	336
5.2.7 Digital Data Service	338
5.2.8 Miscellaneous Special Access Services	338
5.3 <u>Description of Terminating Options</u>	338
5.3.1 Narrowband	339
(A) 0 to 75 Baud Type 1	339
(B) 0 to 75 Baud Type 2	339
(C) 0 to 150 Baud	339
5.3.2 Voice Grade	340
(A) Two-Wire Voice Grade, Non-Data, Without Signaling	340
(B) Four-Wire Voice Grade, Non-Data, Without Signaling	340
(C) Voice Grade Data Termination	340
(D) Two-Wire Voice Grade Station Connecting Facility Termination .	341
(E) Four-Wire Voice Grade Station Connecting Facility Termination.	341
(F) Two-Wire Station Connecting Facility Termination for the Open End of an Off Premises & PBX Extension	341
(G) Dial Reheating Tie Trunk Termination	341
5.3.3 Program Audio	342
(A) 200 to 3500 Hz	342
(B) 100 to 5000 Hz, 50 to 8000 Hz, and 50 to 15000 Hz	342

FACILITIES FOR INTRASTATE ACCESS

TABLE OF CONTENTS	<u>Sheet No.</u>
5. <u>SPECIAL ACCESS</u> (Cont'd)	
5.3 <u>Description of Terminating Options</u> (Cont'd)	
5.3.4 Videoband	343
5.3.5 Wideband Data Service	343
5.3.6 High Capacity Digital	344
(A) High Capacity DS1.....	344
(B) High Capacity DS1C.....	344
(C) Fractional T1 Service.....	344
(D) FiberConnect Service	344
(E) High Capacity Digital DS3.....	345
(F) High Capacity Digital DS3C	345
5.3.7 Digital Data Service	345
5.4 <u>Description of Supplemental Features</u>	346
5.4.1 Bridging	346
(A) Multipoint Data Bridging.....	346
(B) Voice Conference Bridging	346
(C) Alarm Distribution Bridging.....	346
(D) Program Audio Bridging	346
(E) Dataphone Select-A-Station Bridging.....	347
(F) DDS Bridging.....	347
5.4.2 Conditioning Arrangements – Data.....	347
(A) Type C.....	348
(B) Type DA	348
5.4.3 Conditioning – Program Audio	348
(A) Stereo Conditioning	348
(B) Zero Loss	348
5.4.4 Signaling Arrangements.....	349
5.4.5 Echo Control.....	351
(A) Echo Suppression.....	351
(B) Echo Cancellor	352

FACILITIES FOR INTRASTATE ACCESS

TABLE OF CONTENTS	<u>Sheet No.</u>
5. <u>SPECIAL ACCESS</u> (Cont'd)	
5.4 <u>Description of Supplemental Features</u> (Cont'd)	
5.4.6 Improved Return Loss.....	352
5.4.7 Voiceband Facility Switching Arrangement.....	352
5.4.8 Automatic Protection Switch.....	353
5.4.9 Improved Termination Option.....	353
5.4.10 Improved Equal Level Echo Path Loss Option – ELEPL-2.....	354
5.5 <u>Description of Multiplexing Arrangements</u>	354
5.5.1 Voice to Narrowband	355
5.5.2 Group to Voice.....	355
5.5.3 Supergroup to Group	355
5.5.4 Mastergroup to Supergroup	355
5.5.5 DS1 to Voice.....	356
5.5.6 DS1C to Voice	356
5.5.7 DS1C to DS1	357
5.5.8 DS3 to DS1.....	357
5.5.9 DS3C to DS1	357
5.5.10 Group to DS1.....	358
5.5.11 Digital Data Carrier Multiplexer	358
5.5.12 Digital Data Substrate Multiplexer.....	358
5.6 <u>Rate Regulations</u>	359
5.6.1 Types of Rates and Charges.....	359
(A) Monthly Rates.....	359
(B) Daily Rates	359
(C) Hourly Rates.....	360
(D) Nonrecurring Charges.....	360
(1) Special Access Ordering Charges.....	360
(a) Initial Ordering Charge - Special Access.....	361
(b) Subsequent Ordering Charge - Special Access.....	361

FACILITIES FOR INTRASTATE ACCESS

TABLE OF CONTENTS	<u>Sheet No.</u>
5. <u>SPECIAL ACCESS</u> (Cont'd)	
5.6 <u>Rate Regulations</u> (Cont'd)	
5.6.1 Types of Rates and Charges (Cont'd)	
(D) Nonrecurring Charges (Cont'd)	
(2) Service Installation Charge	362
(3) Design Change Charge.....	362
(4) Installation of Supplemental Features and Multiplexing Arrangements	363
(5) Installation of DS1, FiberConnect, FT1, DDS and DS3 Special Special Access Lines	364
(6) Installation of Temporary Voiceband Service	365
(7) Service Rearrangements	365
5.6.2 Minimum Periods	369
5.6.3 Mileage Measurement.....	369
5.6.4 Moves.....	370
(A) Same CDL	370
(B) Different CDL.....	371
5.6.5 Rates and Charges on an Individual Case Basis	372
5.6.6 Hub Wire Centers	373
5.6.7 Shared Use Analog and Digital High Capacity Services	375
5.6.8 Temporary Videoband Service	376
(A) Use of Nonpermanent Facilities for Temporary Videoband Service ..	377
(B) Joint Provisioning of Service	377

WN U-16
Zipty Fiber

Original Sheet 20

FACILITIES FOR INTRASTATE ACCESS

TABLE OF CONTENTS	<u>Sheet No.</u>
5. <u>SPECIAL ACCESS</u> (Cont'd)	
5.6 <u>Rate Regulations</u> (Cont'd)	
5.6.9 High Voltage Protection.....	378
(A) Description.....	378
(B) Provisioning.....	378
(C) Claims and Demands for Damage	380
(D) Network Outage.....	380
(E) Compliance Statement	381
(F) Rate Regulations	381
5.6.10 Metro Ethernet Special Transport	382
(A) Description	382
(B) Conversion of Existing DS1 Transport.....	382
(C) Discontinuance of Service.....	382
(D) Continuation of Service Off the Ring	383
(E) Service Availability.....	383
5.6.11 DS3 High Capacity Service	384
(A) DS3 Rate Structure.....	384
(B) Minimum Service Period	386
(C) Expiration of Minimum Service Period.....	386
(D) Discontinuance Without Liability - DS3 Minimum Service Period	386
(E) Discontinuance With Liability - DS3 Minimum Service Period	386
(F) Notification of Discontinuance	387
(G) DS3 Multiplexer Cross Connect Arrangement	387

WN U-16
Zipty Fiber

Original Sheet 21

FACILITIES FOR INTRASTATE ACCESS

TABLE OF CONTENTS	<u>Sheet No.</u>
5. <u>SPECIAL ACCESS</u> (Cont'd)	
5.6 <u>Rate Regulations</u> (Cont'd)	
5.6.12 Optional Payment Plan (OPP) for FT1, FiberConnect and DDS.....	388
(A) General	388
(B) Changes in Length of OPP Period.....	389
(C) Renewal Options	390
(D) Notification of Discontinuance.....	390
(E) Upgrade to Higher Speed Service.....	391
(F) Termination Liability.....	391
(G) OPP for DDS	391
5.6.13 Optional Payment Plan (OPP) for DS1.....	392
(A) General	392
(B) Conditions.....	393
(C) Moves	393
(D) Changes in Length of OPP Period.....	393
(E) Renewal Options	394
(F) Notification of Discontinuance.....	394
(G) Upgrade to Higher Speed Service.....	394
(H) Termination Liability.....	394
5.7 <u>Rates and Charges</u>	395
5.7.1 Special Access Ordering Charges.....	395
5.7.2 Voiceband Facilities.....	396
5.7.3 Program Audio (200-3500 Hz) Facilities.....	400
5.7.4 Program Audio (100-5000 Hz) Facilities.....	401
5.7.5 Program Audio (50-8000 Hz) Facilities.....	402

WN U-16
Zipty Fiber

Original Sheet 22

FACILITIES FOR INTRASTATE ACCESS

TABLE OF CONTENTS	<u>Sheet No.</u>
5. <u>SPECIAL ACCESS</u> (Cont'd)	
5.7 <u>Rates and Charges</u> (Cont'd)	
5.7.6 Program Audio (50-15000 Hz) Facilities.....	403
5.7.7 High Capacity Digital DS1 (1.544 Mbps) Facilities	404
(A) Standard Arrangements	404
(B) DS1 Optional Payment Plan	405
(C) Optional Arrangements	405
5.7.8 High Capacity Digital DS1C (3.152 Mbps) Facilities	406
5.7.9 High Capacity Digital FiberConnect (6.312 Mbps) Facilities	407
5.7.10 High Capacity Digital Fractional T1 (FT1) Facilities.....	409
(A) Standard Arrangement	409
(B) FT1 Optional Payment Plan.....	410
5.7.11 High Capacity DS3 (44.736 Mbps) Facilities – Three System	413
5.7.12 High Capacity DS3 (44.736 Mbps) Facilities - Individual System	415
5.7.13 High Capacity DS3 (44.736 Mbps) Facilities - Special Transport	416
5.7.14 High Capacity DS3 (44.736 Mbps) Facilities - DS3 Multiplexer Cross Connect Arrangement.....	416
5.7.15 Digital Data Service Facilities	417
5.7.16 Multiplexing Arrangement	420
5.7.17 High Voltage Protection	420
5.7.18 Multiplexing Arrangements.....	421
5.8 <u>Miscellaneous Special Access Services</u>	422
5.8.1 Clear Channel Capability	422
(A) Description of Service	422
(B) Rates	422

WN U-16
Zipty Fiber

Original Sheet 23

FACILITIES FOR INTRASTATE ACCESS

TABLE OF CONTENTS	<u>Sheet No.</u>
6. <u>MISCELLANEOUS SERVICES</u>	
6.1 <u>General</u>	426
6.2 <u>Additional Labor</u>	427
6.2.1 Overtime Installation	427
6.2.2 Overtime Repair.....	427
6.2.3 Additional Installation Testing	428
6.2.4 Standby	428
6.2.5 Testing and Maintenance with Other Telephone Companies.....	428
6.2.6 Charges for Additional Labor.....	429
6.3 <u>Maintenance of Service Charge</u>	430
6.4 <u>Telecommunications Service Priority (TSP) System</u>	431
6.4.1 Description of the Service	431
6.4.2 Obtaining TSP System Service	432
6.4.3 Provisioning Priority	433
6.4.4 Restoration Priority	433
6.4.5 Obligations of the Customer.....	434
6.4.6 Obligations of the Telephone Company.....	435
6.4.7 Rates and Charges	435

WN U-16
Zipty Fiber

Original Sheet 24

FACILITIES FOR INTRASTATE ACCESS

TABLE OF CONTENTS	<u>Sheet No.</u>
6. <u>MISCELLANEOUS SERVICE</u> (Cont'd)	
6.5 <u>Balloting and Allocation Process for Equal Access</u>	437
6.5.1 End User Notification and Equal Access	
Balloting Process	438
(A) InterLATA Equal Access	438
(B) IntraLATA Equal Access	440
6.5.2 Allocation Process	441
6.5.3 Interexchange Carrier Customer Lists	442
6.5.4 End User Choice Discrepancy.....	442
6.5.5 PIC and IPIC Charge Application	445
6.5.6 Unauthorized Primary InterLATA Carrier (PIC) or Primary IntraLATA Carrier (PIC) Restoral Change	445
6.5.7 Multi-party End Users	445
6.5.8 Cancellation of a Carrier Participation	446
6.5.9 Liability of the Telephone Company	446
6.5.10 Carrier Desired Due Date (ICDDD) for PIC or IPIC Installation	446
6.5.11 Rates and Charges	447
6.5.12 Residential and Business Customers-IntraLATA Primary Exchange Carrier ("IPIC") and Primary InterLATA Carrier ("PIC") Change Charge Credit.....	447
6.6 <u>Additional Testing</u>	448
6.6.1 Switched Access Testing	448
6.6.2 Special Access Testing	452
6.6.3 Rates and Charges	453

WN U-16
Zipty Fiber

Original Sheet 25

FACILITIES FOR INTRASTATE ACCESS

TABLE OF CONTENTS	<u>Sheet No.</u>
6. <u>MISCELLANEOUS SERVICE</u> (Cont'd)	
6.7 <u>End User Lists</u>	454
6.7.1 <u>Presubscription Lists</u>	454
(A) <u>InterLATA Equal Access</u>	454
(B) <u>IntraLATA Equal Access</u>	456
6.7.2 <u>Allocations Lists</u>	459
6.7.3 <u>Snapshot List</u>	459
6.7.4 <u>Rates and Charges</u>	460
6.8 <u>Billing Name and Address Services (BNAS)</u>	461
6.8.1 <u>BNA and Data Gathering Services</u>	461
6.8.2 <u>End User Validation List</u>	465
6.8.3 <u>Rates and Charges</u>	466
(A) <u>Billing Name and Address</u>	466
(B) <u>Data Gathering Service</u>	466
(C) <u>End User Validation List</u>	466

WN U-16
Zipty Fiber

Original Sheet 26

FACILITIES FOR INTRASTATE ACCESS

TABLE OF CONTENTS	<u>Sheet No.</u>
7. <u>SPECIALIZED FIA OR ARRANGEMENTS</u>	467
7.1 <u>General</u>	468
8. <u>SPECIAL FACILITIES ROUTING OF FIA</u>	469
8.1 <u>Description of Special Facilities Routing of FIA</u>	470
8.1.1 Diversity	470
8.1.2 Avoidance.....	470
8.1.3 Cable-Only Facilities.....	470
8.2 <u>Rates and Charges</u>	472
8.2.1 Diversity	472
8.2.2 Avoidance.....	472
8.2.3 Diversity and Avoidance Combined.....	472
8.2.4 Cable-Only Facilities.....	472

WN U-16
ZiPLY Fiber

Original Sheet 27

FACILITIES FOR INTRASTATE ACCESS

TABLE OF CONTENTS	<u>Sheet No.</u>
9. SPECIAL CONSTRUCTION.....	473
9.1 <u>General</u>	475
9.1.1 Conditions Requiring Special Construction.....	475
9.1.2 Ownership of Facilities.....	476
9.1.3 Interval to Provide FIA	476
9.1.4 Special Construction Involving Interstate and Intrastate FIA	476
9.2 <u>Liabilities, Charges and Payments</u>	477
9.2.1 General	477
9.2.2 Payment of Charges	477
9.2.3 Start/End of Billing	477
9.2.4 Partial Payments.....	478
9.2.5 Development of Liabilities and Charges	479
9.2.6 Types of Contingent Liabilities	480
(A) Maximum Termination Liability	480
9.2.7 Types of Charges	483
(A) Nonrecurring Charges.....	483
(1) Case Preparation Charge	483
(2) Termination Charge	483
(3) Cancellation Charge	484
(4) Expediting Charge	485
(5) Optional Payment Charge.....	485
(a) Development of Optional Payment Charge	486
(b) Replacement Charge	489
(B) Recurring Charges.....	490
(1) Excess Capacity Charge.....	490
(2) Charge for Route or Type Other Than Normal	493
(3) Lease Charge	497

WN U-16
ZiPLY Fiber

Original Sheet 28

FACILITIES FOR INTRASTATE ACCESS

TABLE OF CONTENTS	<u>Sheet No.</u>
9. SPECIAL CONSTRUCTION (Cont'd)	
9.2 <u>Liabilities, Charges and Payments</u> (Cont'd)	
9.2.8 Application of Charges.....	498
(A) Special Construction of Permanent FIA.....	498
(1) Special Construction When Not Available and There is No Other Requirement for Them	498
(2) Special Construction Using a Route or Type of FIA Other Than Normal	498
(3) Special Construction of a Greater Quantity of FIA Than Necessary to Satisfy the Customer's Order for Service	499
(4) Special Construction Expedited at Greater Cost Than Would Otherwise be Incurred.....	499
(B) Special Construction of Temporary FIA Order	499
9.3 <u>Deferral of the In-Service of FIA</u>	500
9.3.1 General	500
9.3.2 Construction Has Not Started.....	500
9.3.3 Construction Has Started But is Not Complete	501
(A) All FIA Are Deferred.....	501
(B) Some But Not All FIA Are Deferred	501
9.3.4 Construction Complete	501

WN U-16
ZiPLY Fiber

Original Sheet 29

FACILITIES FOR INTRASTATE ACCESS

TABLE OF CONTENTS	<u>Sheet No.</u>
10. <u>PROMOTIONS</u>	502
10.1 <u>IntraLATA Primary Exchange Carrier/Primary Interexchange Carrier (IPIC/PIC) Change Charge</u>	503
11. <u>CARRIER COMMON LINE SERVICE</u>	504
11.1 <u>General Description</u>	506
11.2 <u>Description of Carrier Common Line Service</u>	506
11.2.1 <u>Description</u>	506
11.2.2 <u>Limitations</u>	506
(A) <u>Exclusions</u>	506
(B) <u>WATS/WATS-type Access Lines</u>	506
11.3 <u>Obligations of the Customer</u>	507
11.3.1 <u>Switched Access Service Requirement</u>	507
11.3.2 <u>Supervision</u>	507
11.4 <u>Rate Regulations</u>	507
11.4.1 <u>Description and Application of Rates</u>	507
(A) <u>Billing of Charges</u>	507
(B) <u>Measuring and Recording of Call Detail</u>	508
(C) <u>Unmeasured FGA, FGB, BSA-A and BSA-B Usage</u>	509
(D) <u>Mixed Interstate and Intrastate Usage</u>	509
(E) <u>Determination of Premium and Non-premium Charges</u>	510
11.4.2 <u>Determination of Usage Subjects Carrier Common Line Charge</u>	513
(A) <u>Determination of Jurisdiction</u>	513
(B) <u>Cases Involving Usage Recording by the Customer</u>	513

WN U-16
Zipty Fiber

Original Sheet 30

FACILITIES FOR INTRASTATE ACCESS

TABLE OF CONTENTS	<u>Sheet No.</u>
11. <u>CARRIER COMMON LINE SERVICE</u> (Cont'd)	
11.4 <u>Rate Regulations</u> (Cont'd)	
11.4.3 Resold Services.....	514
(A) Scope.....	514
(B) Customer Obligations Concerning the Resale of MTS/WATS-type Services	515
(C) Resale Documentation Provided by the Customer	515
(D) Rate Regulations Concerning the Resale of MTS/WATS-type Services 516	
(1) Apportionment and Adjustment of Resold Minutes of Use	516
(a) Originating Services.....	516
(b) Terminating Services	517
(2) Same State/Telephone Company/Exchange Limitation.....	518
(3) Direct and Indirect Connections	519
(4) Access Groups and BSAs - Nonequal Access Offices Only	521
(5) Access Groups and BSAs - Equal Access Offices Only	522
(6) Access Groups and BSAs - Nonequal Access and Equal Access Offices.....	523
(7) When the Adjustment Will Be Applied to Customer Bills.....	524
(8) Conversion of Billed Usage to Minutes	524
(9) Mixed Interstate and Intrastate Usage	524
11.5 <u>Rates and Charges</u>	525
12. <u>EXCEPTIONS TO FIA OFFERINGS</u>	526

WN U-16
Zipty Fiber

Original Sheet 31

FACILITIES FOR INTRASTATE ACCESS

TABLE OF CONTENTS	<u>Sheet No.</u>
13. <u>OPERATOR SERVICES</u>	528
13.1 <u>Directory Assistance Service/Preferred Directory Assistance Service</u>	529
13.1.1 General	529
13.1.2 Description of Service	530
13.1.3 Regulations	531
13.1.4 Rate Regulations	536
13.1.5 Rates and Charges	538
13.2 <u>Operator Transfer Service/Inward Operator Assistance Service</u>	539
13.2.1 General Description	539
13.2.2 Provision of Operator Services.....	542
13.2.3 Rate Regulations	543
13.2.4 Rates and Charges	545
14. <u>COIN SERVICES</u>	546
14.1 <u>General</u>	547
14.2 <u>Service Description</u>	547
14.3 <u>Service Provisioning</u>	549
14.4 <u>Collection and Remittance of Coin Station Monies</u>	549
14.5 <u>Provision of Message Call Detail Concerning Coin Station Monies</u>	550
14.6 <u>Payment of Coin Sent - Paid Monies</u>	551
14.6.1 Bill Period Coin Revenue	551
14.6.2 Total Customer Coin Revenue	551
14.6.3 Recourse Adjustments	552
14.6.4 Payment of Net Customer Coin Revenue	552
14.6.5 Audit Provisions	553
15. <u>RATE ZONE WIRE CENTERS</u>	554
15.1 General	554

WN U-16
ZiPLY Fiber

Original Sheet 32

FACILITIES FOR INTRASTATE ACCESS

EXPLANATION OF SYMBOLS

- (C) - To signify changed regulation
- (D) - To signify discontinued rate or regulation
- (I) - To signify increase
- (K) - To signify that material has been transferred to another sheet in the tariff
- (M) - To signify material transferred from another sheet in the tariff
- (N) - To signify new rate or regulation
- (O) - To signify no change
- (R) - To signify reduction
- (T) - To signify a change in text for clarification purposes

EXPLANATION OF ABBREVIATIONS

- AAM - Assumed Access Minutes
- ac - alternating current
- ACAT - Additional Cooperative Acceptance Testing
- ACD - Automatic Call Distributor
- ACNA - Access Customer Name Abbreviation
- AIOD - Automatic Identification of Outward Dialed
- AM - Access Minutes
- ANI - Automatic Number Identification
- ARD - Automatic Ringdown
- ASR - Access Service Request
- AST - Automatic Scheduled Testing
- AT&TC - American Telephone and Telegraph Communications, Inc.
- BHMC - Busy Hour Minutes of Capacity
- BNA - Billing Name and Address
- BNAS - Billing Name and Address Service
- BP - Billing Percentage
- BSA - Basic Serving Arrangement
- BSE - Basic Service Element
- CAC - Carrier Access Code
- CCS - Centum Call-Seconds
- CCSA - Common Control Switching Arrangement(s)
- CCS7 - Common Channel Signaling System 7 Network
- CDL - Customer Designated Location
- CDM - Call Days in Month
- CIC - Carrier Identification Code

WN U-16
Zipty Fiber

Original Sheet 33

FACILITIES FOR INTRASTATE ACCESS

EXPLANATION OF ABBREVIATIONS (Cont'd)

CIP	-	Carrier Identification Parameter
CMF	-	Chargeable Minimum Factor
CN	-	Charge Number
COMPS	-	Central Office Maintenance Planning System
Cont'd	-	Continued
CPN	-	Calling Party Number
CSP	-	Carrier Selection Parameter
CST	-	Cooperative Scheduled Testing
CSU	-	Circuit Switching Unit
DA	-	Digital Data Access
DAM	-	Distance in Airline Miles
dB	-	Decibel
dBm	-	Decibels below one milliwatt
dBmO	-	Transmission Level Referred to the Zero Transmission Level Point
dBrnC0	-	Decibel Reference Noise C-Message Weighted O
dBv	-	Decibels Referred to One Volt
dc	-	direct current
DDS	-	Digital Data Service
DNAL	-	Dedicated Network Access Link
DThF	-	Dual Tone Multifrequency~
DX	-	Duplex
ELEPL	-	Equal Level Echo Path Loss
E&M	-	The Receive and Transmit Leads of a Signaling System
EML	-	Expected Measured Loss
EPL	-	Echo Path Loss
ERL	-	Echo Return Loss
f	-	frequency
FCC	-	Federal Communications Commission
FCO	-	Foreign Central Office
FIA	-	Facilities for Intrastate Access

WN U-16
Zipty Fiber

Original Sheet 34

FACILITIES FOR INTRASTATE ACCESS

EXPLANATION OF ABBREVIATIONS (Cont'd)

GSEC	-	General Services and Equipment Code
HC	-	High Capacity
HNPA	-	Home Numbering Plan Area
Hz	-	Hertz
IA	-	Interface Arrangement
IAM	-	Initial Address Message
IC	-	Interexchange Carrier
ICB	-	Individual Case Basis
ICDDD	-	Carrier Desired Due Date
IDDD	-	International Direct Distance Dialing
ILP	-	Initial Liability Period
IP	-	Interconnection Point
IPIC	-	IntraLATA Primary Exchange Carrier
kbps	-	kilobits per second
kHz	-	kilohertz
LATA	-	Local Access and Transport Area
LEC	-	Local Exchange Carrier
Ma	-	Milliamperes
Mbps	-	Megabits per second
MHz	-	Megahertz
MJU	-	Multi-Junction Unit
MMC	-	Minimum Monthly Charge
MRC	-	Monthly Recurring Charge
MST	-	Manual Scheduled Testing
MTL	-	Maximum Termination Liability
MTS	-	Message Telecommunications Service
NA	-	Not Available
NANP	-	North American Numbering Plan
NECA	-	National Exchange Carrier Association
NPA	-	Numbering Plan Area
NRC	-	Nonrecurring Charge
NST	-	Nonscheduled Testing
NXX	-	Three Digit Central Office Code

WN U-16
ZiPLY Fiber

Original Sheet 35

FACILITIES FOR INTRASTATE ACCESS

EXPLANATION OF ABBREVIATIONS (Cont'd)

OPS	-	Off-Premises Station
PBX	-	Private Branch Exchange
PCM	-	Pulse Code Modulation
PIC	-	InterLATA Primary Exchange Carrier
PIU	-	Percentage Interstate Usage
POT	-	Point of Termination
PTR	-	Percent Traffic Routed
RMC	-	Recurring Monthly Charge
rms	-	root-mean-square
SF	-	Single Frequency
SMDI	-	Simplified Message Desk Interface
SP	-	Signaling Point
SRL	-	Singing Return Loss
SS7	-	Signaling System 7
STP	-	Signal Transfer Point
STR	-	Switched Transport Rate
TDCF	-	Total Day Conversion Factor
TLP	-	Transmission Level Point
TSS	-	Tandem Switch Signaling
TV	-	Television
UL	-	Underutilization Liability
VG	-	Voice Grade
V&H	-	Vertical & Horizontal
WA	-	Wideband Analog
WATS	-	Wide Area Telecommunications Service

WN U-16
Zipty Fiber

Original Sheet 36

FACILITIES FOR INTRASTATE ACCESS

REFERENCE TO OTHER TARIFFS

t

Whenever reference is made in this tariff to other tariffs of the Company, the reference is to the tariffs in force as of the effective date of this tariff, and to amendments thereto and successive issues thereof.

REFERENCE TO TECHNICAL PUBLICATIONS

- (1) NECA Technical Reference Publication AS No. 1 - Issued March 1984; entire issue
Addendum - Issued March 1987
- (2) Technical Interface Reference Manual, Issue 2 -
Issued August 1984, Revised December 1985, August 1986
and October 1988; Sections 3300, 5107, 6000, 6103 and 7000
- (1) AT&T Technical Reference Publication 41014 - Issued February 1978; entire issue
- (2) Service Corporation Telephone Operations - Traffic
Grade of Service Standards, Issued April 1985; entire Issue
- (3) Bellcore Technical Reference Publication TR-TSV-000905,
Issue 1, August 1989
- (4) American National Standards Institute Publications, for
the service category of Frame Relay:
T1.602-1989, Issued 1988
T1.606-1990, Issued 1989
T1.617-1991, Issued 1991
T1.618-1991, Issued 1991
- (4) American National Standards Institute Publication ANSI
T1.102, Issued 1987

- (1) Available from the Federal Communications Commission's Commercial Contractor.
 - (2) Available from Testmark Labs, 3050 Harrodsburg Rd., Lexington, Kentucky 40503.
 - (3) Available from Bellcore T, Customer Service, 8 Corporate Place, Piscataway, New Jersey 08854-4196.
 - (4) Available from American National Standards Institute, 1430 Broadway, New York, NY 10018.
-

Issued: July 29, 2020
Issued by Zipty Fiber
By Jessica Epley, Regulatory & External Affairs Director

Effective: July 31, 2020

WN U-16
Zipty Fiber

Original Sheet 37

FACILITIES FOR INTRASTATE ACCESS

CONCURRENCES

800/877/888 Data Base Query Service

Frontier Communications Northwest, LLC d/b/a Zipty Fiber concurs in Zipty Fiber FCC Tariff 2, together with amendments and successive issues, for the purposes of providing 800/877/888 Data Base Query Service within our serving area.

Issued: July 29, 2020
Issued by Zipty Fiber
By Jessica Epley, Regulatory & External Affairs Director

Effective: July 31, 2020

WN U-16
ZiPLY Fiber

Original Sheet 38

FACILITIES FOR INTRASTATE ACCESS

1. APPLICATION OF TARIFF

- 1.1 This tariff contains regulations, rates and charges applicable to Switched Access, Special Access, and Carrier Common Line Access or, in combination, as Facilities for Intrastate Access, hereinafter referred to as FIA, provided by Frontier Communications Northwest, LLC d/b/a ZiPLY Fiber, hereinafter referred to as the Telephone Company, to InterLATA and IntraLATA customers, including, but not limited to, Interexchange Carriers (ICs), end users, and others subscribing to the services provided in this tariff. This tariff further provides for Miscellaneous Services. This tariff does not apply to other services offered by the Telephone Company.
- 1.2 The provision of such service by the company as described in this tariff is specifically intended to provide exchange network access to customers as follows:
- (A) Interexchange Carriers, who provide service between Local Calling Areas, must purchase services from this tariff for their use in furnishing their authorized intrastate telecommunications services to end user customers, and for operational purposes directly related to the furnishing of such services;
 - (B) Any customer, including but not limited to, Telecommunication Companies and/or Interexchange Carriers, may purchase services from this tariff for their own or administrative use, as specified in other sections of this tariff. Services provided for a customer's own or administrative use may be subject to the rates and charges of other tariffs of the Telephone Company.
- 1.3 Regulations, rates and charges as specified in this tariff apply to FIA and shall not serve as a substitute for IC tariff offerings of services to end users. The provision of such FIA by the Telephone Company as described in this tariff does not constitute a joint undertaking with an IC for the furnishing of any service.
- 1.4 The regulations and rates contained in Section 5, Special Access, apply to Intrastate-InterLATA and Intrastate-IntraLATA facilities. Regulations and rates for dedicated local Intraexchange Special Access Line (SAL) facilities and interoffice mileage established on or after the effective date of this tariff are also found in Section 5 of this tariff.

FACILITIES FOR INTRASTATE ACCESS

SECTION 2 TABLE OF CONTENTS

2. <u>GENERAL REGULATIONS</u>	<u>Sheet No.</u>
2.1 <u>Undertaking of the Telephone Company</u>	41
2.1.1 Scope	41
2.1.2 Limitations	41
2.1.3 Liability	43
2.1.4 Provision of FIA	44
2.1.5 Installation and Termination of FIA.....	44
2.1.6 Maintenance of FIA.....	44
2.1.7 Changes and Substitutions	45
2.1.8 Discontinuance and Refusal of FIA	45
2.1.9 Preemption of FIA.....	46
2.1.10 Limitation of Use of Metallic Facilities	47
2.2 <u>Use</u>	48
2.2.1 Interference or Impairment.....	48
2.2.2 Unlawful Use of FIA	48
2.3 <u>Obligation of the Customer</u>	49
2.3.1 Damages	49
2.3.2 Theft.....	50
2.3.3 Equipment Space and Power	50
2.3.4 Availability for Testing.....	50
2.3.5 Balance	50
2.3.6 Design of Customer Services.....	50
2.3.7 Reserved For Future Use.....	51
2.3.8 Reserved For Future Use.....	51
2.3.9 References to Telephone Company	51
2.3.10 Claims and Demands for Damages	51
2.3.11 Coordination With Respect to Network Contingencies	51
2.3.12 Identification and Rating of VoIP-PSTN Traffic	51.1

FACILITIES FOR INTRASTATE ACCESS

SECTION 2 TABLE OF CONTENTS (Cont'd)

2. <u>GENERAL REGULATIONS</u> (Cont'd)	<u>Sheet No.</u>
2.4 <u>Payment Arrangements and Credit Allowances</u>	52
2.4.1 Payment of Charges and Deposits.....	52
2.4.2 Minimum Periods.....	56
2.4.3 Cancellation of an ASR.....	57
2.4.4 Credit Allowance for FIA Interruptions.....	58
2.5 <u>Connections</u>	61
2.6 <u>Definitions</u>	62
2.7 <u>FIA Services Provided By More Than One Telephone Company</u>	87
2.7.1 General	87
2.7.2 Single Company Billing.....	87
2.7.3 Meet Point Billing.....	88
2.7.4 Zone Density Meet Point Billing	94
2.8 <u>Termination Liability</u>	95
2.8.1 General.....	95
2.8.2 Early Termination Charges	95
2.8.3 End of Term.....	95
2.8.4 Early Termination Liability.....	96
2.8.5 Termination Applicability	96

WN U-16
Zipty Fiber

Original Sheet 41

FACILITIES FOR INTRASTATE ACCESS

2. GENERAL REGULATIONS

2.1 Undertaking of the Telephone Company

2.1.1 Scope

- (A) The Telephone Company does not undertake to transmit calls or offer a telecommunications service under this tariff.
- (B) The Telephone Company shall be responsible only for the installation, operation, and maintenance of the services which it provides.
- (C) The Telephone Company will, for maintenance purposes, test its FIA only to the extent necessary to detect and/or clear troubles. Testing beyond normal parameters will be done as described in Section 6.
- (D) FIA are provided twenty-four hours daily, seven days per week.

2.1.2 Limitations

- (A) The customer may not assign or transfer the use of FIA provided under this tariff except that, where there is no interruption of use or relocation of the FIA, such assignment or transfer may be made to:
 - (1) another customer, whether an individual, partnership, association or corporation, provided the assignee or transferee assumes all outstanding indebtedness for such FIA, and the unexpired portion of the minimum period and the termination liability applicable to such FIA, if any; or

WN U-16
Zipty Fiber

Original Sheet 42

FACILITIES FOR INTRASTATE ACCESS

2. GENERAL REGULATIONS (Cont'd)

2.1 Undertaking of the Telephone Company (Cont'd)

2.1.2 Limitations (Cont'd)

(A) (Cont'd)

- (2) a court appointed receiver, trustee or other person acting pursuant to law in bankruptcy, receivership, reorganization, insolvency, liquidation or other similar proceedings, provided the assignee or transferee assumes the unexpired portion of the minimum period and the termination liability applicable to such FIA, if any.

In all cases of assignment or transfer, the written acknowledgment of the Telephone Company is required prior to such assignment or transfer which acknowledgment shall be made within 15 days from the receipt of notification. All regulations and conditions contained in this tariff shall apply to such assignee or transferee.

The assignment or transfer of FIA does not relieve or discharge the assignor or transferor from remaining jointly or severally liable with the assignee or transferee for any obligations existing at the time of the assignment or transfer.

- (B) The emergency provisioning and restoration of FIA shall be in accordance with 47 CFR § 64.401, which specifies the priority system for such activities.
- (C) The Telephone Company does not warrant that its facilities and services meet standards other than those described in this tariff.

WN U-16
ZiPLY Fiber

Original Sheet 43

FACILITIES FOR INTRASTATE ACCESS

2. GENERAL REGULATIONS (Cont'd)

2.1 Undertaking of the Telephone Company (Cont'd)

2.1.3 Liability

- (A) The Telephone Company's liability, if any, for willful misconduct is not limited by this tariff. With respect to any other claim or suit by a customer for damages associated with the installation, provision, termination, maintenance, repair or restoration of FIA, and subject to the provisions of (B) through (D), the Telephone Company's liability, if any, shall not exceed an amount equal to the proportionate charge for the FIA for the period during which the provision of FIA was affected. This liability for damages shall be in addition to any amounts that may otherwise be due the customer under this tariff as a credit allowance for a provision of FIA interruption.
 - (B) The Telephone Company shall not be liable for any act or omission of any other carrier or customer providing a portion of a service, nor shall the Telephone Company, for its own act or omission, hold liable any other carrier or customer providing a portion of a service.
 - (C) The Telephone Company shall be indemnified, defended and held harmless by the IC or end user against any claim, loss or damage arising from the use of FIA offered under this tariff. The foregoing indemnity shall issue on the IC or the end user separately, each being responsible for its own acts and omissions, involving:
 - (1) Claims for libel, slander, invasion of privacy, or infringement of copyright arising from any communications;
 - (2) Claims for patent infringement arising from combining or using the FIA furnished by the Telephone Company in connection with facilities or equipment furnished by the IC or end user; or
 - (3) All other claims arising out of any act or omission of the IC or end user in the course of using FIA provided pursuant to this tariff.
 - (D) The Telephone Company does not guarantee or make any warranty with respect to its FIA when used in an explosive atmosphere. The Telephone Company shall be indemnified, defended and held harmless by the IC or end user from any and all claims by any person relating to the FIA so provided. The foregoing indemnity shall issue on the IC or the end user separately, each being responsible for its own acts and omissions.
 - (E) Except in the case of willful misconduct, under no circumstances whatever shall the Telephone Company be liable for indirect, incidental, special or consequential damages; and this disclaimer shall be effective notwithstanding any other provisions hereof.
-

WN U-16
ZiPLY Fiber

Original Sheet 44

FACILITIES FOR INTRASTATE ACCESS

2. GENERAL REGULATIONS (Cont'd)

2.1 Undertaking of the Telephone Company (Cont'd)

2.1.3 Liability (Cont'd)

- (F) No license under patents is granted by the Telephone Company to the customer or shall be implied or arise by estoppel in the customer's favor with respect to any circuit, apparatus, system or method used by the customer in connection with FIA provided under this tariff. With respect to claims of patent infringement made by third persons, the Telephone Company will defend, indemnify protect and save harmless the customer from and against all claims arising out of the use by the customer of FIA provided under this tariff.
- (G) The Telephone Company's failure to provide or maintain FIA under this tariff shall be excused by labor difficulties, governmental orders, civil commotions, acts of God and other circumstances beyond the Telephone Company's reasonable control, subject to the interruption allowance provisions of following.
- (H) The Telephone Company shall reimburse the customer for damages to premises or equipment of the customer resulting from the provision of FIA by the Telephone Company on such premises, or by the installation or removal thereof, caused by the negligence or willful act of the Telephone Company.

2.1.4 Provision of FIA

- (A) The Telephone Company, to the extent that such FIA are or can be made available with reasonable effort, and after provisions have been made for the Telephone Company's local service, will provide to the customer, upon reasonable notice, FIA offered in other applicable sections of this tariff at rates and charges specified therein.
- (B) FIA provided to a customer under this tariff may be connected directly to customer facilities and/or may be connected to access facilities of another telephone company or companies in the joint provision of intrastate access.

2.1.5 Installation and Termination of FIA

The FIA provided under this tariff (A) will include any entrance cable or drop wiring and wire or intrabuilding cable to that point where provision is made for termination of the Telephone Company's outside distribution network facilities at a suitable location inside a CDL, and (B) will be installed by the Telephone Company to such point of termination.

2.1.6 Maintenance of FIA

The FIA provided under this tariff shall be maintained by the Telephone Company. The customer or others may not rearrange, move, disconnect, remove or attempt to repair any FIA provided by the Telephone Company, other than by connection or disconnection to any interface means used, except with the written consent of the Telephone Company.

WN U-16
Zipty Fiber

Original Sheet 45

FACILITIES FOR INTRASTATE ACCESS

2. GENERAL REGULATIONS (Cont'd)

2.1 Undertaking of the Telephone Company (Cont'd)

2.1.7 Changes and Substitutions

Except as provided for equipment and systems subject to 47 CFR. § 68.110(b), the Telephone Company may, where such action is reasonably required in the operation of its business, substitute, change, or rearrange any telephone plant used in providing FIA under this tariff, change minimum network protection criteria, change operating or maintenance characteristics of facilities, or change operations or procedures of the Telephone Company. In case of any such substitution, change or rearrangement, the facility parameters will be within generally accepted standards. The Telephone Company shall not be responsible if any such substitution, change or rearrangement renders any customer furnished services obsolete or requires modification or alteration thereof or otherwise affects their use or performance. If such substitution, change, or rearrangement materially affects the operating characteristics or technical parameters of the FIA, as originally ordered by the customer, the Telephone Company will notify the customer in writing prior to making such substitution, change or rearrangement. Notification will be given as follows:

- Should a major change occur, the Telephone Company shall notify the customer at least one year in advance. A major change is described as any change in telephone plant which will affect the technical parameters of the interface (e.g., level, impedance, signaling, interface, bandwidth, two-wire, four-wire, etc.).
- Should a minor change occur, the Telephone Company shall notify the customer at least thirty days in advance. A minor change is described as any change in telephone plant which will not affect the technical parameters of the interface (e.g., level, impedance, signaling, interface, bandwidth, two-wire, four-wire, etc.).

The Telephone Company will work cooperatively with the customer relative to the redesign and implementation required by the change in operating characteristics.

2.1.8 Discontinuance and Refusal of FIA

- (A) Unless the provisions of 2.2.1(B) apply, if the customer fails to comply with the provisions of 2.1.6, 2.3.1, and 2.4.1(D), including any payments to be made by it on the dates or at the times herein specified, and fails within thirty (30) days after written notice, by certified mail, from the Telephone Company to a person designated by the customer to correct such noncompliance, the Telephone Company may discontinue the provision of the FIA to the noncomplying customer. In case of such discontinuance, all applicable charges shall become due.

Issued: July 29, 2020
Issued by Zipty Fiber
By Jessica Epley, Regulatory & External Affairs Director

Effective: July 31, 2020

WN U-16
Zipty Fiber

Original Sheet 46

FACILITIES FOR INTRASTATE ACCESS

2. GENERAL REGULATIONS (Cont'd)

2.1 Undertaking of the Telephone Company (Cont'd)

2.1.8 Discontinuance and Refusal of FIA (Cont'd)

- (B) If the customer repeatedly fails to comply with the provisions of this tariff in connection with the provision of a FIA or group of FIA, and fails to correct such course of action after notice as specified in (A), the Telephone Company may refuse applications for additional FIA to the noncomplying customer until the course of action is corrected.
- (C) The Telephone Company shall deny intrastate access service to a nonregistered telecommunications company that intends to use the requested service to provide telecommunications for hire, sale or resale to the general public within the state of Washington. When applying for intrastate access service from the Telephone Company, the telecommunications company shall state in writing whether the service is intended to be used for intrastate telecommunications for hire, sale or resale to the general public.

2.1.9 Preemption of FIA

In certain instances, i.e., when spare facilities and/or equipment are not available, it may be necessary to preempt existing services to provision or restore National Security Emergency Preparedness (NSEP) Services. If, in its best judgement, the Telephone Company deems it necessary to preempt, then the Telephone Company will ensure that:

- (A) A sufficient number of public switched services are available for public use if preemption of such services is necessary to provision or restore NSEP Service.
- (B) The service(s) preempted have a lower or do not contain NSEP assigned priority levels.
- (C) A reasonable effort is made to notify the preempted service customer of the action to be taken.
- (D) A credit allowance for any preempted service shall be made in accordance with the provisions specified in Section 2.4.4(A).

WN U-16
Zipty Fiber

Original Sheet 47

FACILITIES FOR INTRASTATE ACCESS

2. GENERAL REGULATIONS (Cont'd)

2.1 Undertaking of the Telephone Company (Cont'd)

2.1.10 Limitation of Use of Metallic Facilities

Except for loop and duplex (DX) type signaling, metallic facilities shall not be used for ground return or split pair operation. Signals applied to the metallic facility shall conform to minimum protection criteria for direct electrical connections as specified in 47 CFR § 68.1 et al. In the case of applications of dc telegraph signaling systems, the customer shall be responsible, at its expense, for the provision of current limitation devices to protect the Telephone Company FIA from excessive current due to abnormal conditions and for the provision of noise mitigation networks when required to reduce excess noise.

Interoffice metallic facilities are limited. Interoffice metallic facilities (wire pairs) are in diminishing supply, and can be expected to become less available as optical fiber is deployed and wire cables are removed.

WN U-16
Zipty Fiber

Original Sheet 48

FACILITIES FOR INTRASTATE ACCESS

2. GENERAL REGULATIONS (Cont'd)

2.2 Use

2.2.1 Interference or Impairment

- (A) The characteristics and methods of operation of any circuits, facilities or equipment provided by other than the Telephone Company and associated with the FIA provided under this tariff shall not interfere with or impair service over any facilities of the Telephone Company, its connecting and concurring carriers, or other telephone companies involved in its services, cause damage to their plant, impair the privacy of any communications carried over their facilities, or create hazards to their employees or to the public.
- (B) Except as provided for equipment or systems subject to 47 CFR § 68.110, if such characteristics or methods of operation are not in accordance with (A), the Telephone Company will, where practicable, notify the customer, as appropriate, that temporary discontinuance of the use of FIA may be required; however, where prior notice is not practicable, nothing contained herein shall be deemed to preclude the Telephone Company's right to temporarily discontinue forthwith the use of FIA if such action is reasonable in the circumstances. In case of such temporary discontinuance the customer will be promptly notified and afforded the opportunity to correct the condition which gave rise to the temporary discontinuance. During such period of temporary discontinuance, allowance for interruption of FIA as specified in 2.4.4 is not applicable.

2.2.2 Unlawful Use of FIA

The FIA are furnished subject to the condition that they will not be used for an unlawful purpose. FIA will be discontinued if any law enforcement agency, acting within its apparent jurisdiction, advises in writing that such FIA are being used in violation of law. The Telephone Company will refuse to furnish FIA when it has reasonable grounds to believe that such FIA will be used in violation of law.

Issued: July 29, 2020
Issued by Zipty Fiber
By Jessica Epley, Regulatory & External Affairs Director

Effective: July 31, 2020

WN U-16
ZiPLY Fiber

Original Sheet 49

FACILITIES FOR INTRASTATE ACCESS

2. GENERAL REGULATIONS (Cont'd)

2.3 Obligation of the Customer

2.3.1 Damages

The customer shall reimburse the Telephone Company for damages to the Telephone Company facilities utilized to provide FIA under this tariff caused by the negligence or willful act of the customer, or resulting from the customer's improper use of the Telephone Company facilities, or due to malfunction of any facilities or equipment provided by other than the Telephone Company. Nothing in the foregoing provision shall be interpreted to hold one customer liable for another customer's actions. The Telephone Company will, upon reimbursement for damages, cooperate with the customer in prosecuting a claim against the person causing such damage and the customer shall be subrogated to the right of recovery by the Telephone Company for the damages to the extent of such payment. The amount of reimbursement shall be the actual cost of repair to the damaged facilities including labor costs as specified in 6.2(G).

Issued: July 29, 2020
Issued by ZiPLY Fiber
By Jessica Epley, Regulatory & External Affairs Director

Effective: July 31, 2020

FACILITIES FOR INTRASTATE ACCESS

2. GENERAL REGULATIONS (Cont'd)2.3 Obligation of the Customer (Cont'd)2.3.2 Theft

The customer shall reimburse the Telephone Company for any loss through theft of facilities, apparatus, or equipment utilized to provide FIA under this tariff at the CDL or at the end user's premises. The amount of reimbursement shall be the actual cost for replacement of facilities, apparatus, or equipment lost, plus labor costs as specified in 6.2.6.

2.3.3 Equipment Space and Power

The customer shall furnish or arrange to have furnished to the Telephone Company at no charge, equipment space and electrical power required by the Telephone Company to provide FIA under this tariff at the points of termination of such FIA. The equipment space provided shall meet industry standard environmental conditions. The selection of ac or dc power shall be mutually agreed to by the customer and the Telephone Company. The customer shall also make necessary arrangements in order that the Telephone Company will have access to such spaces at reasonable times for installing, repairing or removing facilities of the Telephone Company.

2.3.4 Availability for Testing

The FIA provided under this tariff shall be available to the Telephone Company at times mutually agreed upon in order to permit the Telephone Company to make tests and adjustments appropriate for maintaining the FIA in satisfactory operating condition. Such tests and adjustments shall be completed within a reasonable time. No credit will be allowed for any interruptions involved during such tests and adjustments.

2.3.5 Balance

All signals for transmission over the FIA provided under this tariff shall be delivered by the customer balanced to ground except for ground start and duplex (DX), McCulloh-loop (alarm system) type signaling, and dc telegraph transmission at speeds of 75 baud or less.

2.3.6 Design of Customer Services

Subject to the provisions of 2.1.7, the customer shall be solely responsible at its expense for the overall design of its services. The IC and end user shall be responsible separately, each at its own expense, for any redesigning or rearrangement of its services which may be required because of changes in FIA, operations or procedures of the Telephone Company, minimum network protection criteria or operating or maintenance characteristics of the FIA.

WN U-16
ZiPLY Fiber

Original Sheet 51

FACILITIES FOR INTRASTATE ACCESS

2. GENERAL REGULATIONS (Cont'd)

2.3 Obligation of the Customer (Cont'd)

2.3.7 Reserved For Futures Use

2.3.8 Reserved For Futures Use

2.3.9 References to Telephone Company

The IC may advise its end users that certain FIA are provided by the Telephone Company in connection with the service the IC furnishes to its end user; however, the IC shall not represent that the Telephone Company jointly participates in the IC's services.

2.3.10 Claims and Demands for Damages

(A) With respect to claims of patent infringement made by third persons, the customer shall defend, indemnify, protect and save harmless the Telephone Company from and against all claims arising out of the combining with, or use in connection with, the FIA provided under this tariff, any circuit, apparatus, system or method provided by the customer, the IC or its end users.

(B) The customer shall defend, indemnify and save harmless the Telephone Company from and against suits, claims, and demands by third persons arising out of the construction, installation, operation, maintenance, or removal of the customer's circuits, facilities, or equipment connected to the Telephone Company's FIA provided under this tariff including, without limitation: Workmen's Compensation claims, actions for infringement of copyright and/or unauthorized use of program material, libel and slander actions based on the content of communications transmitted over the customer's circuits, facilities or equipment, and proceedings to recover taxes, fines, or penalties for failure of the customer to obtain or maintain in effect any necessary certificates, permits, licenses or other authority to acquire or operate the FIA provided under this tariff; provided, however, the foregoing indemnification shall not apply to suits, claims, and demands to recover damages for damage to property, death, or personal injury unless such suits, claims or demands are based on the tortious conduct of the customer, its officers, agents or employees.

2.3.11 Coordination With Respect to Network Contingencies

The customer shall, in cooperation with the Telephone Company, coordinate in planning the actions to be taken to maintain maximum network capability following natural or man-made disasters which affect telecommunications services.

Issued: July 29, 2020
Issued by ZiPLY Fiber
By Jessica Epley, Regulatory & External Affairs Director

Effective: July 31, 2020

WN U-16
Zipty Fiber

Original Sheet 51.1

FACILITIES FOR INTRASTATE ACCESS

2. GENERAL REGULATIONS (Cont'd)

2.3 Obligation of the Customer (Cont'd)

2.3.12 Identification and Rating of VoIP-PSTN Traffic

(A) Scope

- (1) VoIP-PSTN Traffic is defined as traffic exchanged between the Telephone Company end user and the customer in time division multiplexing ("TDM") format that originates and/or terminates in Internet protocol ("IP") format. This section governs the identification of VoIP-PSTN Traffic that is required to be compensated at interstate access rates by the WC Docket No. 10-90, Report and Order FCC-11-161. Specifically, this section establishes the method of separating such traffic (referred to in this tariff as "Relevant VoIP-PSTN Traffic") from the customer's traditional intrastate access traffic, so that such Relevant VoIP-PSTN Traffic can be billed in accordance with the FCC Order.
- (2) This section will be applied to the billing of switched access charges to a customer that is a local exchange carrier only to the extent that the customer has also implemented billing of interstate access charges for Relevant VoIP-PSTN Traffic in accordance with the FCC Order.

(B) Rating of VoIP-PSTN Traffic

The Relevant VoIP-PSTN Traffic identified in accordance with this tariff section will be billed at rates equal to the Telephone Company's applicable tariffed interstate switched access rates as specified in the Telephone Company's applicable Federal Access Tariff.

As of July 13, 2012, any intrastate originating Toll VOIP-PSTN Traffic will be billed at rates equal to the Company's intrastate originating switched access rates as provided in this tariff. Beginning July 1, 2014, any intrastate originating Toll VOIP-PSTN Traffic identified in accordance with this tariff section will be billed at rates equal to the Telephone Company's relevant interstate switched access rates as provided in the Telephone Company's applicable Federal Access Tariff.

Issued: July 29, 2020
Issued by Zipty Fiber
By Jessica Epley, Regulatory & External Affairs Director

Effective: July 31, 2020

WN U-16
ZiPLY Fiber

Original Sheet 51.2

FACILITIES FOR INTRASTATE ACCESS

2. GENERAL REGULATIONS (Cont'd)

2.3 Obligation of the Customer (Cont'd)

2.3.12 Identification and Rating of VoIP-PSTN Traffic (Cont'd)

(C) Calculation and Application of Percent-VoIP-Usage Factor

The Telephone Company will determine the number of Relevant VoIP-PSTN Traffic minutes of use ("MOU") to which interstate rates will be applied under subsection (B), above, by applying a Percent VoIP Usage ("PVU") factor to the total terminating intrastate access MOU received by Telephone Company from the customer. The PVU will be derived and applied as follows: (K)

- (1) The customer will calculate and furnish to the Telephone Company a factor (the "PVU") representing the percentage of the total intrastate and interstate access MOU that the customer terminates to the Telephone Company in the State, that is sent to the Telephone Company and that originated in IP format. This PVU shall be based on information such as traffic studies, actual call detail, or other relevant and verifiable information.
- (2) The Telephone Company will, likewise, calculate a factor (the "PVU-T") representing the percentage of the Telephone Company's total intrastate access MOU in the State that the Telephone Company originates or terminates on its network in IP format. This PVU-T shall be based on information, such as the number of the Telephone Company's retail VoIP subscriptions in the state, traffic studies, actual call detail, or other relevant and verifiable information.
- (3) The Telephone Company will use the PVU-C and PVU-T factors to calculate a PVU factor that represents the percentage of total intrastate MOU exchanged between a Telephone Company end user and the customer that is originated or terminated in IP format, whether at the Telephone Company's end, at the customer's end, or at both ends. The PVU factor will be calculated as the sum of: (A) the PVU-C factor and (B) the PVU-T factor times (1.0 minus the PVU-C factor).
- (4) The Telephone Company will apply the PVU factor to the total terminating intrastate access MOU received from the customer to determine the number of Relevant VoIP-PSTN Traffic MOUs.
- (5) If the customer does not furnish the Telephone Company with a PVU pursuant to the preceding paragraph 1, the Telephone Company will utilize a PVU equal to zero.

WN U-16
Zipty Fiber

Original Sheet 51.3

FACILITIES FOR INTRASTATE ACCESS

2. GENERAL REGULATIONS (Cont'd)

2.3 Obligation of the Customer (Cont'd)

2.3.12 Identification and Rating of VoIP-PSTN Traffic (Cont'd)

(D) Initial PVU Factor

If the PVU factor is not available and/or cannot be implemented in the Telephone Company's billing systems by January 12, 2012, once the factor is available and can be implemented the Telephone Company will adjust the customer's bills to reflect the PVU retroactively to January 12, 2012. This retroactive adjustment will be made to January 12, 2012, provided that the customer provides the factor to the Telephone Company no later than April 15, 2012; otherwise, it will set the initial PVU equal to zero, as specified in subsection (C)(1), preceding.

(E) PVU Factor Updates

The customer may update the PVU factor quarterly using the method set forth in subsection (C)(1), above. If the customer chooses to submit such updates, it shall forward to the Telephone Company, no later than 15 days after the first day of January, April, July and/or October of each year, a revised PVU factor based on data for the prior three months, ending the last day of December, March, June and September, respectively. The revised PVU factor will apply prospectively and serve as the basis for billing until superseded by a new PVU.

(F) PVU Factor Verification

Not more than four times in any year, the Telephone Company may ask the customer to verify the PVU factor furnished to the Telephone Company. The party so requested shall comply, and shall reasonably provide the records and other information used to determine the PVU factors.

FACILITIES FOR INTRASTATE ACCESS

2. GENERAL REGULATIONS (Cont'd)

2.4 Payment Arrangements and Credit Allowances

2.4.1 Payment of Charges and Deposits

- (A) The Telephone Company may, in order to safeguard its interests, require a customer, which has a proven history of late payments to the Telephone Company or does not have established credit, to make a deposit prior to or at any time after the provision of the FIA to the customer to be held by the Telephone Company as a guarantee of the payment of rates and charges. No such deposit will be required of a customer which is a successor of a company which has established credit and has no history of late payments to the Telephone Company. A deposit for a customer with no prior service with the Telephone Company may not exceed the actual or estimated rates and charges for the FIA for a two-month period.

If past service has been provided to the customer, and a deposit is required, the deposit shall be based upon the average monthly billing over the past three months. Such a calculation is subject to revision based upon changes in the average of the past months' billings.

A nontelecommunications company applicant for service (initial occurrence only) shall be entitled to arrange to pay an overdue, unpaid prior obligation over not less than six monthly billing periods. If an applicant defaults on a payment agreement such default shall constitute grounds for discontinuance of service.

The fact that a deposit has been made in no way relieves the customer from complying with the Telephone Company's regulations as to the prompt payment of bills. At such time as the provision of the FIA to the customer is terminated, the amount of the deposit will be credited to the customer's account and any credit balance which may remain will be refunded. After the customer has established a one year prompt payment record, such a deposit will be refunded or credited to the customer account at any time prior to the termination of the provision of the FIA to the customer. In case of a cash deposit, for the period the deposit is held by the Telephone Company, the customer will receive simple annual interest at a rate prescribed by the Commission in accordance with WAC 480-120-128(2).

WN U-16
ZiPLY Fiber

Original Sheet 53

FACILITIES FOR INTRASTATE ACCESS

2. GENERAL REGULATIONS (Cont'd)

2.4 Payment Arrangements and Credit Allowances (Cont'd)

2.4.1 Payment of Charges and Deposits (Cont'd)

- (B) Where the provision of FIA requires facilities that meet any of the conditions specified in 10.1.1, Special Construction charges in Section 10 will apply.
- (C) The Telephone Company shall bill FIA services on a current basis for (a) all charges incurred, (b) applicable taxes, and (c) credits due the customer.
 - (1) Switched Access (except for Entrance Facilities, Direct-Trunked Transport and Multiplexing elements), Ancillary and Miscellaneous services shall be billed in arrears.
 - (2) Special Access, Switched Access Entrance Facilities, Direct-Trunked Transport and Multiplexing elements, shall be billed in advance except for the charges and credits associated with the initial or final bills. The initial bill will also include charges for the actual period of service up to, but not including, the bill date. The unused portion of the FIA already billed will be credited on the final bill.

WN U-16
ZiPLY Fiber

Original Sheet 54

FACILITIES FOR INTRASTATE ACCESS

2. GENERAL REGULATIONS (Cont'd)

2.4 Payment Arrangements and Credit Allowances (Cont'd)

2.4.1 Payment of Charges and Deposits (Cont'd)

(C) (Cont'd)

The customer will receive its bill in 1) a paper format or 2) a paper format bill summary with a magnetic tape to provide the detailed information of the bill, 3) magnetic tape only or 4) via electronic transmission. Such bills are due when rendered regardless of the media used.

Adjustments for the quantities of FIA established or discontinued in any billing period beyond the minimum period in 2.4.2 will be prorated to the number of days based on a 30 day month. The Telephone Company will, upon request and if available, furnish such detailed information as may reasonably be required for verification of any bill.

(D) All bills to the customer are due 31 days (payment date) after the bill date or by the next bill date (i.e., same date in the following month as the bill date), whichever is the shortest interval and regardless of the media utilized. In the event the customer does not remit payment in immediately available funds by the payment date, the FIA may be discontinued as specified in 2.1.8.

(1) If the entire amount billed is not received by the Telephone Company in immediately available funds by the payment date, an additional charge (late payment charge) equal to 1/12th of the percentage rate for deposit interest as that specified in 2.4.1(A) of the unpaid balance will be applied for each month or portion thereof that an outstanding balance remains.

A late payment charge may apply to disputed amounts withheld pending settlement of the dispute. The Telephone Company will credit or assess late payment charges for disputed amounts as specified in 2.4.1(D)(2).

WN U-16
ZiPLY Fiber

Original Sheet 55

FACILITIES FOR INTRASTATE ACCESS

2. GENERAL REGULATIONS (Cont'd)

2.4 Payment Arrangements and Credit Allowances (Cont'd)

2.4.1 Payment of Charges and Deposits (Cont'd)

(D) (Cont'd)

(1) (Cont'd)

If such a payment date would cause payment to be due on a Saturday, Sunday or Holiday (i.e., New Year's Day, Independence Day, Labor Day, Thanksgiving Day, Christmas Day, the second Tuesday in November and a day when Washington's Birthday, Memorial Day or Columbus Day is legally observed), payment for such bills will be due from the customer as follows:

If such a payment date falls on a Sunday or on a Holiday which is observed on a Monday, the payment date shall be the first non-Holiday day following such Sunday or Holiday. If such payment date falls on a Saturday or on a Holiday which is observed on Tuesday, Wednesday, Thursday or Friday, the payment date shall be the last non-Holiday day preceding such Saturday or Holiday.

- (2) In the event of a billing dispute, the Company requests the customer to submit a written explanation of the disputed amount. If the claim is received within 6 months of the payment due date, (i.e. bill date plus 30 days) and the customer has paid the total billed amount, any interest credits due the customer upon resolution of the dispute shall be calculated from the date of overpayment. If the claim for the disputed amount is received more than 6 months from the payment due date, any interest credits due the customer upon resolution of the dispute shall be calculated from the later of the date the claim was received or the date of overpayment. A credit will be granted to the customer for both the disputed amount paid and an amount equal to the percentage rate as specified in 2.4.1(D)(1).

The Telephone Company will assess or credit late payment charges on disputed amounts to the customer as follows:

- If the dispute is resolved in favor of the Telephone Company and the customer has paid the disputed amount on or before the payment due date, no late payment charges will apply.
 - If the dispute is resolved in favor of the Telephone Company and the customer has withheld the disputed amount, any payments withheld pending settlement of the dispute shall be subject to the late payment charge as specified in 2.4.1(D)(1).
-

WN U-16
Zipty Fiber

Original Sheet 56

FACILITIES FOR INTRASTATE ACCESS

2. GENERAL REGULATIONS (Cont'd)

2.4 Payment Arrangements and Credit Allowances (Cont'd)

2.4.1 Payment of Charges and Deposits (Cont'd)

(D) (Cont'd)

(2) (Cont'd)

- If the dispute is resolved in favor of the customer and the customer has withheld the disputed amount, the customer shall be credited for each month or portion thereof that the late payment charge as specified in 2.4.1(D)(1) may have been applied. In the event the customer has paid the late payment charge, a credit will be granted to the customer for both the late payment charge paid on the disputed amount and an amount equal to the percentage rate as specified in 2.4.1(D)(1).

2.4.2 Minimum Periods

- (A) The minimum periods for which FIA are provided and for which rates and charges are applicable are found in 3.2.4.
- (B) The minimum periods for which FIA are provided and for which rates and charges are applicable for Specialized FIA or Arrangements provided on an Individual Case Basis, as described in Section 7, are established with the individual case filing.

WN U-16
Zipty Fiber

Original Sheet 57

FACILITIES FOR INTRASTATE ACCESS

2. GENERAL REGULATIONS (Cont'd)

2.4 Payment Arrangements and Credit Allowances (Cont'd)

2.4.2 Minimum Periods (Cont'd)

(C) For discontinuances of FIA with a one month minimum period, all applicable charges for the one month period will apply. In instances where the minimum period is greater than one month, however, the charge will be the lesser of the Telephone Company's non-recoverable costs less the net salvage value for the discontinued service of the minimum period charges.

2.4.3 Cancellation of an ASR

Provisions for the cancellation of an ASR are described in 3.2.6 for an ASR.

WN U-16
Zipty Fiber

Original Sheet 58

FACILITIES FOR INTRASTATE ACCESS

2. GENERAL REGULATIONS (Cont'd)

2.4 Payment Arrangements and Credit Allowances (Cont'd)

2.4.4 Credit Allowance for FIA Interruptions

(A) General

A FIA is interrupted when it becomes unusable to the customer because of a failure of a component used to furnish FIA under this tariff, or when the service was preempted as a result of invoking NSEP treatment, or when the application of protective controls interrupt all transmission paths as in 4.2.9. A credit allowance will be made for the period in excess of 30 minutes the FIA is interrupted. An interruption period starts when Telephone Company personnel become aware that the FIA is inoperative.

The credit allowance(s) for an interruption or for a series of interruptions shall not exceed the monthly rate or the Minimum Monthly Charge for services so rated for the services interrupted in any one monthly billing period.

A credit allowance for any FIA service will apply for the period specified as follows:

- (1) For Special Access services other than Program Audio, Videoband and for Switched Access Entrance Facilities, Direct-Trunked Transport and Multiplexing services, a credit allowance will be made for an interruption period of 30 minutes or more. The allowance will be calculated at the rate of 1/1440 of the monthly charge for the portion of the FIA affected, for each 30 minutes or major fraction thereof that the interruption continues. A major fraction is considered to be sixteen minutes or more beyond the 30 minute period.

WN U-16
Zipty Fiber

Original Sheet 59

FACILITIES FOR INTRASTATE ACCESS

2. GENERAL REGULATIONS (Cont'd)

2.4 Payment Arrangements and Credit Allowances (Cont'd)

2.4.4 Credit Allowance for FIA Interruptions (Cont'd)

(A) General (Cont'd)

- (2) For Program Audio and Videoband Special Access services, a credit allowance will be made for an interruption of 30 seconds or more. Two or more such interruptions occurring during a period of five consecutive minutes shall be considered as one interruption. The allowance will be calculated as follows:
 - (a) For Program Audio Service provided at monthly rates, the credit will be at the rate of 1/8640 of the monthly service rate.
 - (b) For Program Audio Service provided at daily rates, the credit will be at the rate of 1/288 of the daily rate.
 - (c) For Temporary Videoband Service provided at hourly rates, the credit will be at 1/12 of the hourly rate.
- (3) For Switched Access Service, billed using assumed minutes of use, a credit allowance will be made for an interruption of 24 hours or more. The credit allowance will be calculated at 1/30 of the assumed minutes of use charge for each 24 hours or major fraction thereof that the interruption continues. A major fraction is considered to be 13 hours. No credit will be given where Switched Access billing is based on actual usage.

(B) When Credit Allowance Does Not Apply

No credit allowance will be made for:

- (1) Interruptions caused by the negligence of the customer.
 - (2) Interruptions of a FIA due to the failure of equipment or systems provided by the customer or others.
 - (3) Interruptions of a FIA during any period in which the Telephone Company is not afforded access to the premises where the FIA is terminated.
 - (4) Interruptions of a FIA during an agreed upon period when the customer has released a FIA to the Telephone Company for maintenance purposes, to make rearrangements, or for the implementation of an ASR for a change in the FIA. Should the maintenance, rearrangement, or ASR implementation interruption period extend beyond the agreed upon period, credit allowance will apply.
-

WN U-16
Zipty Fiber

Original Sheet 60

FACILITIES FOR INTRASTATE ACCESS

2. GENERAL REGULATIONS (Cont'd)

2.4 Payment Arrangements and Credit Allowances (Cont'd)

2.4.4 Credit Allowance for FIA Interruptions (Cont'd)

(B) When Credit Allowance Does Not Apply (Cont'd)

- (5) Interruptions of a FIA which continue because of the failure of the customer to authorize replacement of any element of Special Construction, as described in Section 10. The period for which no credit allowance is made begins on the seventh day after the Telephone Company's written notification to the customer of the need for such replacement and ends on the day after receipt of the customer's written authorization for such replacement.
- (6) Periods when the customer elects not to release the FIA for testing and/or repair and continues to use it on an impaired basis.
- (7) An interruption or a group of interruptions, resulting from a common cause, for amounts less than one dollar.

WN U-16
Zipty Fiber

Original Sheet 61

FACILITIES FOR INTRASTATE ACCESS

2. GENERAL REGULATIONS (Cont'd)

2.4 Payment Arrangements and Credit Allowances (Cont'd)

2.4.4 Credit Allowance for FIA Interruptions (Cont'd)

(C) Use of an Alternative Service Provided by the Telephone Company

Should the customer elect to use an alternative service provided by the Telephone Company during the period that a FIA is interrupted, the customer must pay the tariffed rates and charges for the alternative service used.

(D) Temporary Surrender of a FIA

In certain instances, the customer may be requested to surrender a FIA for purposes other than maintenance, testing or activity relating to an ASR. If the customer consents, or in the instance of preemption under NSEP treatment as described in Section 2.1.9, a credit allowance will be granted. The credit allowance will be determined in accordance with 2.4.4(A).

2.5 Connections

Equipment and systems (i.e., terminal equipment, multiline terminating systems, and communications systems) may be connected with Switched and Special Access furnished by the Telephone Company where such connection is made in accordance with the provisions specified in the NECA Technical Reference Publication AS No. 1 and in 2.1. of this tariff.

WN U-16
Zipty Fiber

Original Sheet 62

FACILITIES FOR INTRASTATE ACCESS

2. GENERAL REGULATIONS (Cont'd)

2.6 Definitions

Certain terms used herein are defined as follows:

Access Area

The term "Access Area" denotes a specific calling area containing those customers served by one or more Central Offices associated with the various Switched Access provisions offered under this tariff. The size and configuration of the Access Area a customer obtains is dependent upon the Feature Group type and the specific characteristics of the Central Office or Access Tandem office to which the connection is made.

Access Code

The term "Access Code" applies to Switched Access Service. It denotes a uniform five or seven digit code dialed by an end user to access an Interexchange Carrier's facilities. The Carrier Access Code (CAC) has the form of 101XXXX and the Carrier Identification Code (CIC) has the form 950-XXXX.

Access Minutes

The term "Access Minutes" denotes that usage of exchange facilities in intrastate service for the purpose of calculating chargeable usage. On the originating end of an intrastate call, usage is measured from the time the originating End User's call is delivered by the Telephone Company to and acknowledged as received by the customer's facilities connected with the originating exchange. On the terminating end of an intrastate call, usage is measured from the time the call is received by the End User in the terminating exchange. Timing of usage at both originating and terminating ends of an intrastate call shall terminate when the calling or called party disconnects, whichever event is recognized first in the originating and terminating end exchanges, as applicable. For the calculation of total minutes, seconds are totaled and converted to minutes before rounding occurs. Remainder seconds greater than 29 are rounded to a minute.

WN U-16
Zipty Fiber

Original Sheet 63

FACILITIES FOR INTRASTATE ACCESS

2. GENERAL REGULATIONS (Cont'd)

2.6 Definitions (Cont'd)

Access Service Request

The term "Access Service Requests" (ASR) denotes a document (i.e., order) used by the Telephone Company to process a customer's request for Access Services as offered throughout this tariff.

Access Tandem

The term "Access Tandem" denotes a telephone company switching system that provides a traffic concentration and distribution function for traffic originating from or terminating at end offices in the access area.

Answer/Disconnect Supervision

The term "Answer/Disconnect Supervision" denotes the transmission of the switch trunk equipment supervisory signal (off-hook or on-hook) to the CDL for terminating calls to a Telephone Company end office as an indication that the called party has answered or disconnected.

Answer Message

The term "Answer Messages" denotes an SS7 message sent in the backward direction to indicate that the call has been answered.

Application Date

The term "Application Date" denotes the date the Access Service Request (ASR) is received by the Telephone Company.

Attempt

The term "Attempt" denotes a call in the originating direction from an end user to a CDL which is completed (answered) or not completed (not answered) and a call in the terminating direction from a CDL to a customer which is completed (answered) or not completed (not answered).

Attenuation Distortion

The term "Attenuation Distortion" denotes the difference in loss at specified frequencies relative to the loss at 1004 Hz.

WN U-16
Zipty Fiber

Original Sheet 64

FACILITIES FOR INTRASTATE ACCESS

2. GENERAL REGULATIONS (Cont'd)

2.6 Definitions (Cont'd)

Balance (100-Type) Test Line

The term "Balance (100-Type) Test Line" denotes a standard feature of FGA, FGB, FGC, FGD, 800, 877 and 888 Access Service and refers to the end office termination provided for balance and noise testing. The termination provides off-hook supervision to the calling end, and terminates the line or trunk in a resistive and capacitive arrangement which simulates the characteristic impedance of the end office.

Basic Service Element

The term "Basic Service Element (BSE)" denotes an unbundled service option available only with Basic Serving Arrangements.

Basic Servicing Arrangement

The term "Basic Servicing Arrangement (BSA)" denotes a category of Switched Access Service differentiated by technical characteristics, e.g., line side versus trunk side connection at the Telephone Company's first point of switching.

BHMC

See Busy Hour Minutes of Capacity.

Bit

The term "Bit" denotes a binary digit, the smallest unit of information in the binary system of notation.

Bridging

The term "Bridging" denotes the connection of one or more circuits in parallel with another circuit without interrupting the continuity of the first circuit.

Bridging Wire Center

The term "Bridging Wire Center" denotes the Telephone Company designated wire center in which bridging is accomplished.

WN U-16
ZiPLY Fiber

Original Sheet 65

FACILITIES FOR INTRASTATE ACCESS

2. GENERAL REGULATIONS (Cont'd)

2.6 Definitions (Cont'd)

Business Day

The term "Business Day" denotes the times of day that a company is open for business. Generally, in the business community, these are 8:00 or 9:00 a.m. to 5:00 or 6:00 p.m., respectively, with an hour for lunch, Monday through Friday, resulting in a standard forty (40) hour workweek.

Busy Hour Minutes of Capacity

The term "Busy Hour Minutes of Capacity" (BHMC) denotes the trunk group usage load consisting of the average usage load for the busy season.

Busy Season

The term "Busy Season" denotes the four consecutive weeks of the calendar year having the highest daily busiest hour traffic load based on a five day week. Normally the five-day week consists of Monday through Friday. Where weekend traffic is greater than weekday traffic, one or both weekend days may be used as a substitute for a weekday as long as a consistent five-day week is maintained for the four consecutive weeks.

Byte

The term "Byte" denotes a sequence or group of eight bits that represent one character.

Carrier Identification Code

The term "Carrier Identification Code" (CIC) identifies the uniform access code associated with the Switched Access usage for a specific Interexchange Carrier.

C-Conditioning

The term "C-Conditioning" denotes a Telephone Company special treatment of the transmission path in order to control attenuation and envelope delay distortion.

WN U-16
Zipty Fiber

Original Sheet 66

FACILITIES FOR INTRASTATE ACCESS

2. GENERAL REGULATIONS (Cont'd)

2.6 Definitions (Cont'd)

C-Message Noise

The term "C-Message Noise" denotes the frequency weighted average noise within an idle voice circuit. The frequency weighing, called C-message, is used to simulate the frequency characteristic of the 500-type telephone set and the hearing of the average subscriber.

C-Notched Noise

The term "C-Notched Noise" denotes the frequency-weighted noise on a voice circuit with a holding tone, which is removed at the measuring end through a notch (very narrow band) filter.

CCS

The term "CCS" denotes a hundred-call seconds which is a standard unit of traffic load that is equal to 100 seconds of usage or capacity of a group of lines or trunks.

Call

The term "Call" denotes a communication including an off-hook signal and routing information initiated at the originating location and completed to a terminating location.

Carrier Identification Parameter

The term "Carrier Identification Parameter" (CIP) denotes a field in the SS7 Initial Address Message (IAM) that identifies and transmits CIC information in a forward direction to an IC customer.

Central Office

The term "Central Office" denotes a telephone company local switching system where telephone company local service subscriber station loops are terminated for purposes of interconnection to each other and to trunks.

WN U-16
Zipty Fiber

Original Sheet 67

FACILITIES FOR INTRASTATE ACCESS

2. GENERAL REGULATIONS (Cont'd)

2.6 Definitions (Cont'd)

Central Office Loop Around Test Line

The term "Central Office Loop Around Test Line" denotes equipment in the Telephone Company's end office which provides a means for making two-way transmission tests for Switched Access services. These transmission tests are normally for the measurement of level and noise tests. This arrangement has two terminations, each reached by means of a separate seven digit number.

Central Office Prefix

The term "Central Office Prefix" denotes the first three digits (NXX) of the telephone number assigned to a Telephone Company subscriber's local service.

Centralized Automatic Reporting on Trunks (CAROT) Testing

The term "Centralized Automatic Reporting on Trunks (CAROT) Testing" denotes a type of testing which includes the capacity for measuring the 1000 Hz loss, C-message weighted noise, C-notched noise, loss slope, and the provision of a balance termination.

Channelize

The term "Channelize" denotes the process of multiplexing-demultiplexing circuits using analog or digital techniques.

WN U-16
ZiPLY Fiber

Original Sheet 68

FACILITIES FOR INTRASTATE ACCESS

2. GENERAL REGULATIONS (Cont'd)

2.6 Definitions (Cont'd)

Circuit

The term "Circuit" denotes an electrical or photonic, in the case of fiber optic based transmission systems, communications path between two or more points of termination.

Circuit Code

The term "Circuit Code" denotes the service class routing of an SS7 call that indicates the interexchange carrier trunk group to which the traffic will be routed (e.g., 0+, 0-, 500, 900, etc.).

Common Channel Signaling System 7 Network (CCS7)

The term "Common Channel Signaling System 7 Network (CCS7)" denotes a dedicated out of band signaling network which utilizes Signaling System 7 (SS7) protocol to provide call handling and data base access service.

Common Line

The term "Common Line" denotes a line, trunk, coin line or other facility provided under the Telephone Company's Tariff, WN U-17, terminated on a Central Office switch. A Common Line provides access to: 1) the local calling area as defined in Tariff WN U-17, 2) authorized long distance carriers, and 3) service codes (e.g., 411, 611, 911). A Common Line - Residence is a line or trunk provided under the residence regulations of Tariff WN U-17. A Common Line Business is a line provided under the business regulations of Tariff, WN U-17. A coin line is a line provided under the public and/or semi-public service regulations of Tariff WN U-17.

Communications System

The term "Communications System" denotes circuits and other facilities which are capable of communications between terminal equipment provided by other than the Telephone Company or Telephone Company stations.

Confirmed ASR

The term "Confirmed ASR" denotes a customer's ASR for a) Switched Access FIA which the Telephone Company has processed with the Engineering Department to confirm for the customer and the Telephone Company the availability of facilities and/or equipment, and b) Special Access FIA for which the Telephone Company confirms to the customer that the established due date can be met. The date the ASR is confirmed, the standard service date interval commences.

WN U-16
ZiPLY Fiber

Original Sheet 69

FACILITIES FOR INTRASTATE ACCESS

2. GENERAL REGULATIONS (Cont'd)

2.6 Definitions (Cont'd)

Confirming Design Layout Report Date

The term "Confirming Design Layout Report (CDLR) Date" identifies the date that the Telephone Company is scheduled to receive confirmation that the Design Layout Report provided by the Telephone Company for a confirmed ASR is acceptable.

Conventional Signaling

The term "Conventional Signaling" denotes the inter-machine signaling system which has been traditionally used in North America for the purpose of transmitting the called number's address digits from the originating end office to the switching machine which will terminate the call. In this system, all of the dialed digits are received by the originating switching machine, a path is selected, and the sequence of supervisory signals and outpulsed digits is initiated. No overlap outpulsing, ten-digit ANI, ANI information digits, or acknowledgement wink are included in this signaling sequence.

Customer

The term "Customer" denotes any individual, partnership, association, joint stock company, trust, corporation, or governmental entity or any other entity which subscribes to the services offered under this tariff, including Interexchange Carriers (ICs), end users and Information Service Providers.

WN U-16
Zipty Fiber

Original Sheet 70

FACILITIES FOR INTRASTATE ACCESS

2. GENERAL REGULATIONS (Cont'd)

2.6 Definitions (Cont'd)

Customer Designated Location

The term "Customer Designated Location" (CDL) denotes a location specified by the customer for the purpose of terminating FIA services. The Telephone Company must have access to the location to perform installation, testing, and maintenance functions. The customer may or may not have access to the location. CDLs include locations such as customer premises, end user premises, customer repeater stations, customer microwave towers, a Telephone Company's first point of switching, some other point where Telephone Company testing can occur, etc. A CDL may be designated by the customer for Switched Access, Special Access, or both in combination.

D-Conditioning

The term "D-Conditioning" denotes a Telephone Company special treatment of the transmission path in order to control C-notched noise and intermodulation distortion.

Daily Busiest Hour

The term "Daily Busiest Hour" denotes the highest usage hour for each day with the reading taken on the clock hour or half hour. The clock hour or half hour selection varies from day to day, depending upon the usage measured. The Daily Busiest Hour is also known as the Bouncing Busy Hour.

Data Transmission (107-Type) Test Line

The term "Data Transmission (107-Type) Test Line" denotes an arrangement which provides for the connection to a signal source which provides test signals for one-way testing of data and voice transmission parameters.

Dual Tone Multifrequency Address Signaling

The term "Dual Tone Multifrequency (DTMF) Address Signaling", denotes a type of signaling that is an optional feature of FGA and BSA-A. It may be utilized when FGA or BSA-A is being used in the terminating direction. An office arranged for signaling would expect to receive address signals from the IC in the form of DTMF format.

WN U-16
Zipty Fiber

Original Sheet 71

FACILITIES FOR INTRASTATE ACCESS

2. GENERAL REGULATIONS (Cont'd)

2.6 Definitions (Cont'd)

Echo Path Loss

The term "Echo Path Loss" denotes the measure of reflected signal at a four-wire interface without regard to the send and receive Transmission Level Point (TLP).

Echo Return Loss

The term "Echo Return Loss" denotes a frequency weighted measure of return loss over the middle of the voiceband (approximately 500 to 2500 Hz) where talker echo is most annoying.

End Office Switch

The term "End Office Switch" denotes a Telephone Company local switching system located in a wire center where Telephone Company local service subscriber station loops are terminated for purposes of originating and terminating traffic to or from a customer.

End User

The term "End User" means any customer of an intrastate telecommunications service that is not a carrier, except that a carrier, other than the Telephone Company, shall be deemed to be an "end user" to the extent that such carrier uses a telecommunications service for administrative purposes, and a person or entity that offers telecommunications services exclusively as a reseller shall be deemed to be an "end user" if all resale transmissions offered by such reseller originate on the premises of such reseller (e.g., hotels, motels and shared tenant services).

Engineering Review

The term "Engineering Review" denotes the examination of an ASR with a customer requested change to determine if a design change is required. It includes, but is not limited to, the review for possible change requirements in equipment, interfaces, circuit configurations, engineering records, and billing.

Entry Switch

See First Point of Switching

Excess Capacity

The term "Excess Capacity" denotes a quantity of FIA requested by the customer which is greater than that which the Telephone Company would construct to fulfill the customer's ASR.

Issued: July 29, 2020
Issued by Zipty Fiber
By Jessica Epley, Regulatory & External Affairs Director

Effective: July 31, 2020

WN U-16

Zipty Fiber

Original Sheet 72

FACILITIES FOR INTRASTATE ACCESS

2. GENERAL REGULATIONS (Cont'd)

2.6 Definitions (Cont'd)

Exchange

The term "Exchange" denotes a unit generally smaller than a Local Access and Transport Area (LATA), established by the Telephone Company for the administration of communications service in a specified area which usually embraces a city, town or village and its environs. It consists of one or more central offices together with the associated facilities used in furnishing communications service within that area. One or more designated exchanges comprise a given LATA.

Exchange Access Signaling

The signaling system which is used, by equal access end offices, to transmit originating information and address digits to the customer's premises and includes the means of verifying the receipt of these address digits. Features of this system include overlap outpulsing, identification of the type of call, identification of the ten-digit telephone number of the calling party, and acknowledgement wink supervisory signals.

Exit Message

The term "Exit Message" denotes an SS7 message sent to an end office by the Telephone Company tandem switch to mark the carrier connect time when the Telephone Company's tandem switch sends an Initial Address Message to the Interexchange Customer.

WN U-16
Zipty Fiber

Original Sheet 73

FACILITIES FOR INTRASTATE ACCESS

2. GENERAL REGULATIONS (Cont'd)

2.6 Definitions (Cont'd)

Extended Area Service

The term "Extended Area Service" (EAS) denotes an arrangement whereby a customer in one exchange can call a local number in another exchange that is part of the extended area without paying a toll charge.

Firm Order Confirmation Date

The term "Firm Order Confirmation (FOC) Date" denotes the date that the Telephone Company will provide the schedule of dates for the provisioning activities associated with the customer's request for service.

First Point of Switching

The term "First Point of Switching" denotes either the first telephone company location at which switching occurs on the terminating path of a call proceeding from the CDL to the terminating end office or the last telephone company location at which switching occurs on the originating path of a call proceeding from the originating end office to the CDL.

Four-Wire to Two-Wire Conversion

The term "Four-Wire to Two-Wire Conversion" denotes an arrangement which converts a four-wire transmission path to a two-wire transmission path to allow a four-wire facility to terminate in a two-wire entity such as a central office switch trunk circuit or switching system.

WN U-16
ZiPLY Fiber

Original Sheet 74

FACILITIES FOR INTRASTATE ACCESS

2. GENERAL REGULATIONS (Cont'd)

2.6 Definitions (Cont'd)

Ground Start Supervisory Signaling

The term "Ground Start Supervisory Signaling" denotes a type of signaling which provides for the application of ground on the tip side of the point of termination (assuming no signaling conversion has been provided by the Telephone Company) as an initial seizure signal before the application of ringing in the originating direction (towards the customer from the end office).

Immediately Available Funds

The term "Immediately Available Funds" denotes a corporate or personal check drawn on a bank account and funds which are available for use by the receiving party on the same day on which they are received and includes U.S. Federal Reserve bank wire transfers, U.S. Federal Reserve notes (paper cash), U.S. coins, U.S. Postal Money Orders and New York Certificates of Deposit.

Individual Case Basis

The term "Individual Case Basis" (ICB) denotes a condition where the regulations, if applicable, rates and charges for an offering under the provisions of this tariff are developed based on the circumstances in each case.

Information Service Provider

The term "Information Service Provider" denotes one who offers a capability for generating, acquiring, storing, transforming, processing, retrieving, utilizing, or making available information which may be conveyed via telecommunications, except that such service does not include (1) any use of any such capability for the management, control, or operation of a telecommunications system or the management of a telecommunications service, or (2) the provision of time, weather, and such other similar audio services that are offered by local exchange companies.

Initial Address Message (IAM)

The term "Initial Address Message" denotes an SS7 message sent in the forward direction to trunk set up with the busy of an outgoing trunk which carries the information about that trunk along with other information relating to the routing and handling of the call to the next switch.

Installed Cost

The term "Installed Cost" denotes the total investment (estimated or actual) by the Telephone Company to provide facilities for the offered services.

Interexchange Carrier (IC) or Interexchange Common Carrier

The terms "Interexchange Carrier" (IC) or "Interexchange Common Carrier" denote any individual, partnership, association, joint stock company, trust, governmental entity or corporation engaged for hire in intrastate communication by wire or radio, within a LATA or between two or more LATAs.

WN U-16
Zipty Fiber

Original Sheet 75

FACILITIES FOR INTRASTATE ACCESS

2. GENERAL REGULATIONS (Cont'd)

2.6 Definitions (Cont'd)

Intermodulation Distortion

The term "Intermodulation Distortion" denotes a measure of the nonlinearity of a circuit. It is measured using four tones, and evaluating the ratios (in dBs) of the transmitted composite four-tone signal power to the second-order products of the tones (R2), and the third-order products of the tones (R3).

Interstate Communications

The term "Interstate Communications" denotes both interstate and foreign communications.

Intrastate Communications

The term "Intrastate Communications" denotes any communications within a state subject to oversight by a state regulatory commission as provided by the laws of the State of Washington.

Kilosegment

The term "Kilosegment" denotes a unit of packet transmission defined as 64,000 bytes of data; one thousand segments.

WN U-16
Zipty Fiber

Original Sheet 76

FACILITIES FOR INTRASTATE ACCESS

2. GENERAL REGULATIONS (Cont'd)

2.6 Definitions (Cont'd)

Line

The term "Line" denotes a communications path connecting an end office switch with an end user's premises or a CDL for the provision for FGA or BSA-A.

Line Group

The term "Line Group" denotes a grouping of lines which are traffic engineered as a unit for the establishment of connections between end office switches and customers in which all of the communications paths are interchangeable.

Line Side Connection

The term "Line Side Connection" denotes a connection of a transmission path to the line side of an end office system.

Local Access and Transport Area

The term "Local Access and Transport Area" (LATA) denotes a geographic area for the provision and administration of communications service. It encompasses designated Access Areas which are grouped to serve common social, economic, and other purposes.

Local Area Network (LAN)

A network permitting the interconnection and intercommunication of a group of computers, primarily for the sharing of resources such as data storage devices and printers.

FACILITIES FOR INTRASTATE ACCESS

2. GENERAL REGULATIONS (Cont'd)2.6 Definitions (Cont'd)Logical Channel

The term "Logical Channel" denotes a communication channel which allows two-way simultaneous transmission of data packets through the network. No circuit capability is preassigned to a logical channel. Capacity is made available as the data is transmitted. Each virtual connection utilizes one logical channel.

Maximum Termination Liability

The term "Maximum Termination Liability" (MTL) denotes the maximum amount of money for which the customer is liable in the event all FIA ordered in a Special Construction case are discontinued before a specified period of time.

Maximum Termination Liability Period

The term "Maximum Termination Liability Period" denotes the length of time the customer is liable for a termination charge in the event specially constructed FIA are terminated. The MTL period is equal to the average account life of the FIA provided.

Mid Link

The term "Mid Link" denotes the Special Transport facilities between Hub Wire Centers where the circuit is bridged and/or where switching devices such as a loop transfer arrangement are located.

Milliwatt (102 Type) Test Line

The term "Milliwatt (102-Type) Test Line" denotes an arrangement in an end office which provides a 1004 Hz tone at 0 dBm0 for one-way transmission measurements towards the CDL from the Telephone Company end office.

MTS Access

The term "MTS Access" is an access service using a combination of Switched Access Service and Carrier Common Line Service as offered within this tariff.

Multicarrier Access Area

The term "Multicarrier Access Area" denotes an EAS for FGA and BSA-A or an area for FGB and BSA-B where FIA Services are provided by more than one telephone company in which a customer obtains access to an entire EAS or FGB or BSA-B area by obtaining a FGA or BSA-A or FGB or BSA-A access tandem arrangement that connects its switch with the First Point of Switching of the Primary Exchange Carrier.

WN U-16
Zipty Fiber

Original Sheet 78

FACILITIES FOR INTRASTATE ACCESS

2. GENERAL REGULATIONS (Cont'd)

2.6 Definitions (Cont'd)

National Security Emergency Preparedness (NSEP) Services

The term "National Security Emergency Preparedness (NSEP) Services" denotes telecommunications services which are used to maintain a state of readiness or to respond to and manage any event or crisis (local, national or international), which causes or could cause injury or harm to the population, damage to or loss of property, or degrades or threatens the NSEP posture of the United States.

Net Salvage

The term "Net Salvage" denotes the estimated scrap, sale, or trade-in value, less the estimated cost of removal. Cost of removal includes the costs of demolishing, tearing down, removing, or otherwise disposing of the material and any other applicable costs. Because the cost of removal may exceed salvage, facilities may have negative net salvage.

Network Address

The term "Network Address" denotes the alphanumeric character string used to specify the destination of each switched connection made within the network.

Network Channel Interface Code

The "Network Channel Interface" code (NCI) is an ordering code that provides an indication of the generic channel type. The NCI code provides the technical characteristics of the interface and describes the physical and electrical characteristics of the special access interface to the CDLs. A complete description and listing of these interface codes is specified in Section 6103 of the Technical Interface Reference Manual.

Nonrecoverable Cost

The term "Nonrecoverable Cost" denotes the cost of specially constructed facilities for which the Telephone Company has no foreseeable use should the customer terminate service.

Nonsynchronous Test Line

The term "Nonsynchronous Test Line" denotes an arrangement in step-by-step end offices which provides operational tests which are not as complete as those provided by the synchronous test lines, but which can be made more rapidly.

North American Numbering Plan

The term "North American Numbering Plan" denotes a three-digit area or Numbering Plan Area (NPA) code and a seven-digit telephone number made up of a three-digit Central Office code (NXX) plus a four-digit station number (XXXX).

WN U-16
Zipty Fiber

Original Sheet 79

FACILITIES FOR INTRASTATE ACCESS

2. GENERAL REGULATIONS (Cont'd)

2.6 Definitions (Cont'd)

NSEP Treatment

The term "NSEP Treatment" denotes the provisioning of a telecommunications service before others based on the provisioning priority level assigned by the Executive Office of the President.

Octet

The term "Octet" denotes a group of eight binary digits operated upon as an entity.

Off-Hook

The term "Off-Hook" denotes the active condition of Switched Access or a Telephone Company local service line.

On-Hook

The term "On-Hook" denotes the idle condition of Switched Access or a Telephone Company local service line.

Open Circuit Test Line

The term "Open Circuit Test Line" denotes an arrangement in an end office which provides an ac open circuit termination of the trunk or line by means of an inductor of several Henries.

WN U-16
Zipty Fiber

Original Sheet 80

FACILITIES FOR INTRASTATE ACCESS

2. GENERAL REGULATIONS (Cont'd)

2.6 Definitions (Cont'd)

Operator Services Switching Location (OSSL)

A Telephone Company office where Telephone Company equipment processes Operator Service calls to or from a customer designated location in the same LATA.

Order Interval

The term "Order Interval" denotes the interval between the Application Date and the Service Date.

Originating Direction

The term "Originating Direction" denotes the use of Switched Access for the origination of calls from an end user to a CDL.

Overlap Outpulsing

The term "Overlap Outpulsing" is the feature of the exchange access signaling system which permits initiation of pulsing to the customer's premises before the calling subscriber has completed dialing an originating call.

OZZ Code

The term "OZZ Code" identifies the service class routing code of a multifrequency (MF) call that indicates the interexchange carrier trunk group to which the traffic will be routed (e.g., 0+, 0-, 900, etc.).

WN U-16
Zipty Fiber

Original Sheet 81

FACILITIES FOR INTRASTATE ACCESS

2. GENERAL REGULATIONS (Cont'd)

2.6 Definitions (Cont'd)

Packet

The term "Packet" denotes a continuous sequence of binary digits of information which is switched through the network as an integral unit. The user data is divided into segments for billing purposes. The number of segments contained in a packet is dependent upon the packet size.

Packet Switch

The term "Packet Switch" denotes a central office based switch that establishes a virtual connection between two data network addresses for the transmission of discrete amounts of information.

Packet Switching Office

The term "Packet Switching Office" denotes the central office where the packet switching functions are performed and access to the packet network is accomplished.

Permanent Virtual Circuit

The term "Permanent Virtual Circuit" denotes a logical channel, defined in software, from one end user location to another. It allows a packet to be sent over a dedicated logical channel without call set up or clearing.

Plant Test Date

The term "Plant Test Date" denotes the date on which installation is completed and the Telephone Company to customer testing can begin.

Point of Termination

The term "Point of Termination" denotes the point of demarcation at a CDL or end user premises at which the Telephone Company's responsibility for the provision of FIA Service ends.

Premises

The term "Premises" denotes a building or buildings on continuous property (except Railroad Right-of-Way, etc.) not separated by a public highway.

WN U-16
ZiPLY Fiber

Original Sheet 82

FACILITIES FOR INTRASTATE ACCESS

2. GENERAL REGULATIONS (Cont'd)

2.6 Definitions (Cont'd)

Pre-service Testing

The term "Pre-service Testing" denotes tests performed on a FIA to assure standard transmission performance/parameters meet specifications prior to acceptance testing.

Primary Exchange Carrier

The term "Primary Exchange Carrier (PEC)" denotes the telephone company in whose exchange a customer's first point of switching (i.e., dial tone for FGA or BSA-A, an access tandem for FGB or BSA-B) is located.

Protocol

The term "Protocol" denotes a set of rules governing the format to be followed when transmitting information between communicating devices.

Public Pay Telephone

The term "Public Pay Telephone" denotes a switched coin line provided under the Public Telephone Service regulations of the Telephone Company Local Tariffs.

Recoverable Cost

The term "Recoverable Cost" denotes the cost of specially constructed facilities for which the Telephone Company has a foreseeable reuse, either in place or elsewhere should the customer terminate service.

Registered Equipment

The term "Registered Equipment" denotes the customer's terminal equipment which complies with or has been approved within the Registration Provisions of 47 CFR § 68.1 et al.

Release Message

The term "Release Message" denotes an SS7 message sent in either direction to indicate that a specific circuit is being released.

Route Mileage

The term "Route Mileage" denotes the actual Telephone Company provided facility mileage of a transmission circuit.

Issued: July 29, 2020
Issued by ZiPLY Fiber
By Jessica Epley, Regulatory & External Affairs Director

Effective: July 31, 2020

WN U-16
ZiPLY Fiber

Original Sheet 83

FACILITIES FOR INTRASTATE ACCESS

2. GENERAL REGULATIONS (Cont'd)

2.6 Definitions (Cont'd)

Scheduled Issue Date

The term "Scheduled Issue Dated" denotes the date the Telephone Company is scheduled to issue the confirmed ASR to all associated work groups.

Secondary Exchange Carrier

The term "Secondary Exchange Carrier (SEC)" denotes the telephone Company in whose exchange a customer does not subscribe to FGA or BSA-A, or FGB or BSA-B service, but from whose exchange the customer's end user can call the interexchange switch or CDL of an IC in the primary exchange of another telephone company on a toll-free basis.

Segment

The term "Segment" denotes a unit of user information consisting of 64 octets or less. Billing for Packet Switching Network Service is based on the number of segments transmitted within the user data field of a packet. The number of segments transmitted within a packet is limited only by the subscribed or negotiated maximum size of the user data field for the customer interface.

Semi-Public Pay Telephone

The term "Semi-Public Pay Telephone" denotes a switched coin line provided under the Semi-Public Telephone Service regulations of the Telephone Company Local Tariffs.

Service Date

The term "Service Date" denotes the date that the FIA is to be placed in service. A confirmed ASR is required to establish a service date.

Seven-Digit Manual Test Line

The term "Seven-Digit Manual Test Line" denotes a set of optional features for all Switched Access which allow the IC to select balance, milliwatt, and synchronous test lines of FGA and BSA-A, by manually dialing a seven-digit number over the associated Switched Access.

Short Circuit Test Line

The term "Short Circuit Test Line" denotes the end office circuit which provides an ac short circuit termination of the trunk or line by means of a capacitor of at least 4 microfarads.

WN U-16
Zipty Fiber

Original Sheet 84

FACILITIES FOR INTRASTATE ACCESS

2. GENERAL REGULATIONS (Cont'd)

2.6 Definitions (Cont'd)

Signaling Point (SP)

The term "Signaling Point (SP)" denotes an SS7 network interface element capable of originating and/or terminating SS7 messages.

Signaling System 7 (SS7)

The term "Signaling System 7 (SS7)" denotes the layered protocol used for standardized common channel signaling in the United States.

Signaling Transfer Point (STP)

The term "Signaling Transfer Point (STP)" denotes a packet switch which provides access to the Telephone Company's SS7 network and performs SS7 message signal routing and screening. The technical interface specifications, transmission specifications, and diversity requirements for interconnecting to the Telephone Company's SS7 network at the STP are as described in Bellcore Technical Reference Publication TR-TSV-000905.

Statistical Multiplexing

A multiplexing technique in which timeslots are dynamically allocated on the basis of need rather than being predetermined; the data is typically transmitted on a first served basis.

FACILITIES FOR INTRASTATE ACCESS

2. GENERAL REGULATIONS (Cont'd)

2.6 Definitions (Cont'd)

Synchronous Test Line

The term "Synchronous Test Line" denotes an arrangement of an end office which performs marginal operational tests of supervisory and ring-tripping functions.

Tandem Switch Signaling

The term "Tandem Switch Signaling" identifies the carrier identification code (CIC) and the OZZ code or circuit code. The CIC identifies the uniform access code associated with the Switched Access usage for a specific interexchange carrier. The OZZ code identifies the service class routing code of a multifrequency (MF) call that indicates the interexchange carrier trunk groups to which the traffic will be routed. The circuit code identifies the service class routing of an SS7 call that indicates the interexchange carrier trunk group to which the traffic will be routed.

Telecommunications Service Priority (TSP) System

The term "Telecommunications Service Priority (TSP) System" or "TSP System" or "NSEP TSP System" refers to the regulatory, administrative and operational system authorizing and providing for priority treatment (i.e., the provisioning and restoration) of NSEP Services.

Temporary Facilities

The term "Temporary Facilities" denotes facilities used to provide FIA to a customer for less than the minimum service period or less than one month, whichever is longer, or to provide FIA while permanent facilities are being constructed.

Terminating Direction

The term "Terminating Direction" denotes the use of Switched Access for the completion of calls from a CDL to an end user.

Trunk

The term "Trunk" denotes a communications path connecting two switching systems in a network, used in an end-to-end connection.

WN U-16
Zipty Fiber

Original Sheet 86

FACILITIES FOR INTRASTATE ACCESS

2. GENERAL REGULATIONS (Cont'd)

2.6 Definitions (Cont'd)

Trunk Group

The term "Trunk Group" denotes a grouping of trunks which are traffic engineered as a unit for the establishment of connections between switching systems in which all of the communications paths are interchangeable.

Trunk Side Connection

The term "Trunk Side Connection" denotes the connection of a transmission path to the trunk side of an end office switch.

V&H Coordinates Method

The term "V&H Coordinates Method" denotes a method of computing airline miles between two points by utilizing an established formula which is based on the Vertical (V) and Horizontal (H) coordinates of the two points.

Virtual Connection

The term "Virtual Connection" denotes a logical channel resulting from call establishment to a network address that exists until the call is terminated by either party.

WATS Access

The term "WATS Access" is an access service offered for the provision of long distance services. It is provided at the closed end of WATS or 800/877/888 Service and does not allow for the completion of local calls as defined in the Telephone Company's General and Local Exchange Service Catalog, Section 3. WATS Access is provided using a combination of Switched Access Service and Special Access Service as offered within this tariff.

WATS Serving Office

The term "WATS Serving Office" denotes a telephone company designated serving wire center where switching, screening and/or recording functions are performed in connection with a Special Access Line used with a Switching Interface as described in 4.2.5(U).¹

Wire Center

The term "Wire Center" denotes a location in which one or more central office switches, and cross connection equipment used for the provision of Telephone Company telecommunications services, are located.

Wire Center Area

The term "Wire Center Area" denotes the geographic area served by a Wire Center through the use of central office switching equipment, cross connection equipment, and subscriber loops.

¹ The use of the terms WATS or WATS-type throughout this tariff is primarily for ordering purposes and is not intended to restrict the use of the customer services when ordering Special and Switched Access in combination.

WN U-16
Zipty Fiber

Original Sheet 87

FACILITIES FOR INTRASTATE ACCESS

2. GENERAL REGULATIONS (Cont'd)

2.7 FIA Services Provided By More Than One Telephone Company

2.7.1 General

When Switched Transport or Special Transport service is provided by more than one telephone company, the telephone companies involved will mutually agree upon one of the billing methods as described in 2.7.2 or 2.7.3 based upon the type of access service and the interconnection arrangements between the telephone companies.

The Telephone Company will notify the customer which billing method will be used. The customer will place the ASR as described in 3.3.

2.7.2 Single Company Billing

The Single Company Billing method may be applied to FGA Switched Access Service.

The telephone company receiving the ASR from the customer, as specified in 3.3(A)(1), will arrange to provide the service, determine the applicable charges and bill the customer for the entire service in accordance with its Access tariff. The airline mileage, if applicable, is determined using the V&H method as described in the National Exchange Carrier Association (NECA) Tariff FCC No. 4.

WN U-16
Zipty Fiber

Original Sheet 88

FACILITIES FOR INTRASTATE ACCESS

2. GENERAL REGULATIONS (Cont'd)

2.7 FIA Services Provided By More Than One Telephone Company (Cont'd)

2.7.3 Meet Point Billing

Meet Point Billing is required when an access service is provided by multiple Telephone Companies for FGB, FGC and FGD Switched Access Services and Special Access. It is optional for FGA Switched Access Services.

There are two Meet Point Billing Options -- Single Bill and Multiple Bill. The Telephone Company must notify the customer of: (1) the Meet Point Billing Option that will be used, (2) the Telephone Company(s) that will render the bill(s), (3) the Telephone Company(s) to whom payment(s) should be remitted, and (4) the Telephone Company(s) that will provide the bill inquiry function. The Telephone Company shall provide such notification at the time that an ASR is placed requesting access service. Additionally, the Telephone Company shall provide this notice in writing 30 days in advance of any change.

(A) Single Bill Option

The Single Bill Option allows the customer to receive one bill from one telephone company or its billing agent for access services.

The Telephone Company(s) that renders the bill to the customer may provide to the customer, cross references to the other Telephone Company(s) service and/or the common circuit identifiers based upon industry standards. Should a billing dispute arise, the terms and conditions of the Billing Company(s) will apply.

For usage rated access services the access minutes of use will be compiled by the Initial Billing Company and used by the Initial Billing Company and any subsequent Billing Company(s) for the development of access charges.

- The Initial Billing Company for FGB, FGC and FGD Switched Access services is normally the end user's serving office and for WATS usage the Initial Billing Company is normally the WATS serving office. When the Initial Billing Company is other than the normally designated Telephone Company, the Telephone Company will notify the customer.
- The Subsequent Billing Company(s) is any Telephone Company(s) in whose territory a segment of the Switched Transport facility is provided and/or where the CDL is located.

WN U-16
Zipty Fiber

Original Sheet 89

FACILITIES FOR INTRASTATE ACCESS

2. GENERAL REGULATIONS (Cont'd)

2.7 FIA Services Provided By More Than One Telephone Company (Cont'd)

2.7.3 Meet Point Billing (Cont'd)

(A) Single Bill Option (Cont'd)

The Single Bill option provides three billing alternatives, Single Bill/Single Tariff, Single Bill/Pass-Through Billing and Single Bill/Multiple Tariff which are described following:

(1) Single Bill/Single Tariff

Each Telephone Company will receive an ASR or a copy of the ASR from the customer as specified in 3.3(A)(2) and arrange to provide the service. The Initial Billing Company will:

- determine the applicable charges and bill in accordance with its tariff;
- include all recurring and nonrecurring rates and charges of its tariff; and
- forward the bill to the customer.

The customer will remit the payment to the Initial Billing Company.

(2) Single Bill/Pass-Through Billing

Each Telephone Company will receive an ASR or a copy of the ASR from the customer as specified in 3.3(A)(2) and arrange to provide the service. Each Telephone Company will:

- determine its usage portion of Switched Transport and/or mileage portion of Special Transport as described in 2.7.3(C);
- determine the applicable charges and bill in accordance with its tariff;
- include all recurring and nonrecurring rates and charges of its tariff; and
- forward the bill to the Initial Billing Company for meet point billed access services.
- apply usage data, when needed, to the bill and calculate the charges;
- identify each involved Telephone Company's charges separately on the bill;
- combine all the bills of the involved Telephone Companies of a meet point billed access service into one access bill;
- forward-the bill to the customer; and
- advise the customer how to remit the payment, either directly to each Telephone Company involved in the provision of this meet point billed service; or, as a single payment made to the Initial Billing Company. If payments are to be sent directly to the Initial Billing Company, the Subsequent Billing Company(s) will provide the customer with written authorization for the payment arrangement.

FACILITIES FOR INTRASTATE ACCESS

2. GENERAL REGULATIONS (Cont'd)2.7 FIA Services Provided By More Than One Telephone Company (Cont'd)2.7.3 Meet Point Billing (Cont'd)(A) Single Bill Option (Cont'd)

(3) Single Bill/Multiple Tariff

Each Telephone Company will receive an ASR or a copy of the ASR from the customer as specified in 3.3(A)(2) and arrange to provide the service. The Initial Billing Company will:

- determine each Telephone Company's usage portion of switched transport and/or mileage portion of special transport as described in 2.7.3(C);
- determine the applicable charges and bill in accordance with each Telephone Company's tariff;
- include all recurring and nonrecurring charges for each involved Telephone Company
- identify each involved Telephone Company's charges separately on the bill;
- forward the bill to the customer; and
- advise the customer how to remit the payment, either directly to each Telephone Company involved in the provision of this meet point billed service; or, as a single payment made to the Initial Billing Company. If payments are to be sent directly to the Initial Billing Company, the Subsequent Billing Company(s) will provide the customer with written authorization for the payment arrangement.

(B) Multiple Bill Option

The Multiple Bill option allows all Telephone Companies providing service to bill the customer for their portion of a jointly provided access service. Each Telephone Company will:

- determine its usage portion of the Switched Transport and/or mileage portion of Special Transport as described in 2.7.3(C);
- determine the applicable charges and bill in accordance with its tariff;
- include all recurring and nonrecurring rates and charges of its tariff; and
- forward the bill to the customer.

The customer will remit the payments directly to each Telephone Company.

WN U-16
Zipty Fiber

Original Sheet 91

FACILITIES FOR INTRASTATE ACCESS

2. GENERAL REGULATIONS (Cont'd)

2.7 FIA Services Provided By More Than One Telephone Company (Cont'd)

2.7.3 Meet Point Billing (Cont'd)

(C) Meet Point Billing Mileage Calculation

Each Telephone Company's portion of the Switched Transport and/or Special Transport mileage will be determined as follows:

- (1) For Switched Access Tandem-Switched Transport Services, determine the appropriate Tandem-Switched Transport - Facility total miles by computing the number of miles from the wire center that normally serves the CDL, or the access tandem if Direct-Trunked Transport is ordered directly to the access tandem, to the serving wire center in the Access Area (i.e., end user serving wire center, or WATS Serving Office), using the V&H method as described in the NECA Tariff FCC No. 4. For Special Access Service and Switched Access Direct-Trunked Transport determine the appropriate Special Transport or Direct-Trunked Transport total miles by computing the number of miles between the serving wire centers involved (i.e., CDL serving wire center, Hub wire center, WATS Serving Office) using the V&H method as described in the NECA Tariff FCC No. 4. Where the calculated miles includes a fraction, the value is rounded up to the next full mile.
- (2) Determine the billing percentage (BP), as described in the NECA Tariff FCC No. 4. This represents the portion of the Service provided by each telephone company.
- (3) For Switched Access Tandem-Switched Transport; when Tandem Switched Transport is provided to a terminating carrier different from a Telephone ILEC Company, Terminating – Tandem 3rd party rates are applicable otherwise Terminating –Tandem End Office rates are applicable. When originating Tandem Switched Transport is provided, Originating rates are applicable. To determine the Switched Access Tandem-Switched Transport (a) multiply the number of access minutes of use times the number of airline miles as specified in (1), times the BP of each Telephone Company as specified in (2), times the Tandem-Switched Transport - Facility rate; (b) multiply the Tandem-Switched Transport - Termination rate times the number of access minutes times the quantity of terminations.

Example of Billing Percentage (BP) Method Using the Multiple Bill Option:

The Tandem-Switched Transport - Facility between Office X and Office Y is jointly provided by telephone companies A and B. The following example reflects the rate for telephone company A. Rate for telephone company B would appear in its appropriate Access Tariff.

WN U-16
Zipty Fiber

Original Sheet 92

FACILITIES FOR INTRASTATE ACCESS

2. GENERAL REGULATIONS (Cont'd)

2.7 FIA Services Provided By More Than One Telephone Company (Cont'd)

2.7.3 Meet Point Billing (Cont'd)

(C) Meet Point Billing Mileage Calculation (Cont'd)

(3) (Cont'd)

(a) Airline miles from telephone company A (office X) to telephone company B (office Y) = 50 airline miles as found in NECA Tariff FCC No. 4.

(b) Billing Percentage for each telephone company (from NECA Tariff FCC No. 4).

Telephone Company A = 40%
Telephone Company B = 60%

(c) Access Minutes for Telephone Company A = 9000.

(d) Tandem-Switched Transport - Facility rate for Telephone Company A = SWT FAC

(e) Tandem-Switched Transport - Termination Rate = SWT TERM

NOTE: The Tandem-Switched Transport-Termination rate does not apply in situations where the Telephone Company is an intermediate, non-terminating Local Exchange Carrier involved in the provision of the Switched Transport Facility.

WN U-16
ZiPLY Fiber

Original Sheet 93

FACILITIES FOR INTRASTATE ACCESS

2. GENERAL REGULATIONS (Cont'd)

2.7 FIA Services Provided By More Than One Telephone Company (Cont'd)

2.7.3 Meet Point Billing (Cont'd)

(C) Meet Point Billing Mileage Calculation (Cont'd)

(3) (Cont'd)

Formula:

Access Minutes (AM) x Airline Miles (ALM) x Billing Percentage (BP) x Tandem-Switched Transport - Facility Rate (SWT FAC) + [Tandem-Switched Transport - Termination Rate (SWT TERM) x Access Minutes (AM) x Quantity of Terminations (TERMS)] = Total

Calculation:

Telephone Company A

AM ALM BP SWT FAC SWT TERM AM TERMS
9,000 x 50 x .40 x SWT FAC [SWT TERM x 9,000 x TERMS]=TOTAL

(4) For Special Access and for Switched Access Direct-Trunked Transport, multiply the number of airline miles as in (1), times the BP for each telephone company as in (2), times the Special Transport or Direct-Trunked Transport Facility rates elements. For DS1 and DS3 Special Transport and DS1 and DS3 Direct-Trunked Transport, multiply the Special Transport Termination or Direct-Trunked Transport Termination rate times the number of terminations provided by the Telephone Company.

WN U-16
ZiPLY Fiber

Original Sheet 93.1

FACILITIES FOR INTRASTATE ACCESS

2. GENERAL REGULATIONS (Cont'd)

2.7 FIA Services Provided By More Than One Telephone Company (Cont'd)

2.7.3 Meet Point Billing (Cont'd)

(C) Meet Point Billing Mileage Calculation (Cont'd)

(5) Example 1 – Originating Switched Access

- Feature Group D Switched access is ordered to End Office.
- Originating End Office and Access Tandem are in the operating territory of a Telephone Company (TC-A).
- Customer Designated Premises is in the operating territory of a Telephone Company (TC-B)
- Assumptions:
 - TC-A Direct Trunk Transport BP = 40%
 - TC-B Direct Trunk Transport BP = 60%
 - Direct Trunked Transport mileage = 26 mi.
 - Tandem Switched Transport mileage = 23 mi.
- Telephone Company A charges are:
 - End Office charges = 9,000 min. x EO rate
 - Tandem Switched Transport Facility charge = 9,000 min. x 23 mi. x TSF rate
 - Tandem Switched Transport Termination charge = 2 terminations x 9,000 min. x TST rate
 - Tandem Switching Rate = 9,000 min. x TS rate
 - Direct Trunked Facility charge = 26 mi. x DTF rate x 40%
 - Direct Trunked Termination charge = 1 termination x DTT rate
 - Shared Multiplexing charge = 9,000 min. x 23 mi. x SM rate

WN U-16
ZiPLY Fiber

Original Sheet 93.2

FACILITIES FOR INTRASTATE ACCESS

2. GENERAL REGULATIONS (Cont'd)

2.7 FIA Services Provided By More Than One Telephone Company (Cont'd)

2.7.3 Meet Point Billing (Cont'd)

(C) Meet Point Billing Mileage Calculation (Cont'd)

(6) Example 2 – Terminating Switched Access – Tandem 3rd Party

- Feature Group D Switched Access is ordered to End Office.
- Terminating Access Tandem is owned by Telephone ILEC Companies (TC-A) and end office is owned by a non-Telephone ILEC Company.
- Assumptions:
 - TC-A Direct Trunk Transport BP = 40%
 - TC-B Direct Trunk Transport BP = 60%
 - Direct Trunk Transport mileage = 26 mi.
 - TC-A Tandem Switched Transport BP = 20%
 - TC-B Tandem Switched Transport BP = 80%
 - Tandem Switched Transport mileage = 23 mi.
- Telephone Company A charges are:
 - Tandem Switched Transport Facility-3rd Party charge = 9,000 min. x 23 mi. x TSF-3rd Party rate x 20%
 - Tandem Switched Transport Termination-3rd Party charge = 1 termination x 9,000 min. x TST – 3rd Party rate
 - Tandem Switching-3rd Party Rate = 9,000 min. x TS-3rd Party rate
 - Direct Trunked Facility charge = 26 mi. x DTF rate x 40%
 - Direct Trunked Termination charge = 1 termination x DTT rate
 - Shared Multiplexing 3rd Party Charge = 9,000 min. x 23 mi. x SM-3rd Party rate

WN U-16
ZiPLY Fiber

Original Sheet 93.3

FACILITIES FOR INTRASTATE ACCESS

2. GENERAL REGULATIONS (Cont'd)

2.7 FIA Services Provided By More Than One Telephone Company (Cont'd)

2.7.3 Meet Point Billing (Cont'd)

(C) Meet Point Billing Mileage Calculation (Cont'd)

(7) Example 3 –Terminating Switched Access Tandem End Office

- Feature Group D Switched Access is ordered to End Office.
- Terminating End Office and Access Tandem are both owned by Telephone ILEC Companies (TC-A).
- Assumptions:
 - TC-A Direct Trunk Transport BP = 40%
 - TC-B Direct Trunk Transport BP = 60%
 - Direct Trunk Transport mileage = 26 mi.
 - Tandem Switched Transport mileage = 23 mi.
- Telephone Company A charges are:
 - End office Charges = 9,000 min. x EO rate
 - Tandem Switched Facility – End Office charge = 9,000 min. x 23 mi. x TSF-End Office rate.
 - Tandem Switched Transport Termination –End Office charge = 2 terminations x 9.000 min. x TST-End Office rate.
 - Tandem Switching – End Office charge = 9,000 min. x TS-End Office rate
 - Direct Trunked Facility Charge = 26 mi x DTF rate x 40%
 - Direct Trunked Termination charge – 1 termination x DTT rate
 - Shared Multiplexing charge = 9,000 min. x 23 mi. x SM rate

WN U-16
ZiPLY Fiber

Original Sheet 93.4

FACILITIES FOR INTRASTATE ACCESS

2. GENERAL REGULATIONS (Cont'd)

2.7 FIA Services Provided By More Than One Telephone Company (Cont'd)

2.7.3 Meet Point Billing (Cont'd)

(C) Meet Point Billing Mileage Calculation (Cont'd)

(8) Example 4 –Terminating Switched Access-Tandem 3rd Party

- Feature Group D Switched Access is ordered to End Office.
- Terminating Access Tandem is owned by Telephone ILEC Companies (TC-A). Terminating End Office is owned by a non-Telephone ILEC Company.
- Assumptions:
 - Direct Trunk Transport mileage = 26 mi.
 - TC-A Tandem Switched Transport BP = 20%
 - TC-B Tandem Switched Transport BP = 80%
 - Tandem Switched Transport mileage = 23 mi.
- Telephone Company A charges are:
 - Tandem Switched Transport Facility-3rd Party charge = 9,000 min. x 23 mi. x TSF-3rd Party rate x 20%
 - Tandem Switched Transport Termination-3rd Party charge = 1 termination x 9,000 min. x TST – 3rd Party rate
 - Tandem Switching-3rd Party Rate = 9,000 min. x TS-3rd Party rate
 - Direct Trunked Facility charge = 26 mi. x DTF rate
 - Direct Trunked Termination charge = 2 terminations x DTT rate
 - Shared Multiplexing-3rd Party Charge = 9,000 min. x 23 mi. x SM-3rd Party rate

WN U-16
Zipty Fiber

Original Sheet 93.5

FACILITIES FOR INTRASTATE ACCESS

2. GENERAL REGULATIONS (Cont'd)

2.7 FIA Services Provided By More Than One Telephone Company (Cont'd)

2.7.3 Meet Point Billing (Cont'd)

(C) Meet Point Billing Mileage Calculation (Cont'd)

(9) Example 5 – Originating Switched Access Telephone ILEC Company owns only the End Office.

- Feature Group D Switched Access is ordered to End Office.
- End Office is owned by Telephone ILEC Companies (TC-A).
- Access Tandem is owned by a non-Telephone ILEC Company (TC-B)
- Assumptions:
 - Direct Trunk Transport mileage = 26 mi.
 - TC-A Tandem Switched Transport BP = 80%
 - TC-B Tandem Switched Transport BP = 20%
 - Tandem Switched Transport mileage = 23 mi.
- Telephone Company A charges are:
 - End Office Charges = 9,000 min. x EO rate
 - Tandem Switched Transport Facility charge = 9,000 min. x 23 mi. x TSF rate x 80%.
 - Tandem Switched Transport Termination charge = 1 termination x 9,000 min. x TST rate.

(10) Example 6 – Terminating Switched Access – Tandem 3rd Party

- Feature Group D Switched Access is ordered to End Office.
 - End Office is owned by Telephone ILEC Companies (TC-A).
 - Access Tandem is owned by a non-Telephone ILEC Company (TC-B)
 - Telephone Company A charges are:
 - End Office Charges = 9,000 min. x EO rate
 - Tandem Switched Transport Facility-3rd Party charge = 9,000 min. x 23 mi. x TSF-3rd Party rate x 80%.
 - Tandem Switched Transport Termination-3rd Party charge = 1 termination x 9,000 min. x TST-3rd Party rate.
-

Issued: July 29, 2020
Issued by Zipty Fiber
By Jessica Epley, Regulatory & External Affairs Director

Effective: July 31, 2020

WN U-16
Zipty Fiber

Original Sheet 93.6

FACILITIES FOR INTRASTATE ACCESS

2. GENERAL REGULATIONS (Cont'd)

2.7 FIA Services Provided By More Than One Telephone Company (Cont'd)

2.7.3 Meet Point Billing (Cont'd)

- (D) All other appropriate recurring and nonrecurring charges in each telephone company's Access tariff are applicable.
- (E) Where the Tandem-Switched Transport - Facility is provided by more than one Telephone Company, the Tandem-Switched Transport - Termination rate applies for the termination at the Telephone Company end of the Tandem-Switched Transport (i.e., the first point of switching or the end office serving the end user). The Tandem-Switched Transport - Termination rate will not apply when the Telephone Company is the intermediate provider of the Switched Transport Facility.
- (F) The shared Trunk Port for Tandem-Switched Transport shall be billed by the Telephone Company in whose territory the end office is located.

FACILITIES FOR INTRASTATE ACCESS

2. GENERAL REGULATIONS (Cont'd)

2.7 FIA Services Provided By More Than One Telephone Company (Cont'd)

2.7.4 Zone Density Meet Point Billing

When the Switched Transport facility (Direct-Trunked or Tandem-Switched Transport) is provided by more than one telephone company the following regulations apply:

(A) Switched Access

(1) End Office or Access Tandem is in Telephone Company Territory:

- (a) Distance sensitive transport provided by the Telephone Company will be rated according to the zone of the Telephone Company's end office or the Telephone Company's access tandem.
- (b) The transport termination provided by the Telephone Company will be rated according to the zone assigned to the Telephone Company's end office or the Telephone Company's access tandem.
- (c) Tandem Switching will be rated according to the zone of the Telephone Company's access tandem.

(2) The Telephone Company is the intermediate provider of transport:

- (a) Distance sensitive transport will be rated at Zone 1 rates.
- (b) The transport termination rate does not apply if the Telephone Company is the intermediate provider of the transport facility.

WN U-16
ZiPLY Fiber

Original Sheet 95

FACILITIES FOR INTRASTATE ACCESS

2. GENERAL REGULATIONS (Cont'd)

2.8 Termination Liability

2.8.1 General

In the event the service is terminated by the customer prior to completion of the current term commitment period, the customer shall be liable for an early termination charge, except as noted below. The amount of the early termination charge will be 25% of the monthly recurring charge(s) (MRC) for the remainder of the term. For example:

$25\% \times \text{MRC} \times \# \text{ of Lines/Channels/Paths} \times \text{Remainder of Term} = \text{Termination Charge}$

2.8.2 Early Termination Charges

Early termination charges will apply only to those rate elements under a term commitment period. If any rates for the service are increased during the term period, exclusive of any increase due to local, state, or federal fees, taxes or surcharges, the customer may terminate the service without incurring an early termination charge.

2.8.3 End of Term Options

- (A) Prior to the end of the term commitment period, the customer may select one of the following options, to be effective at the end of the term:
- (1) Renew their term commitment,
 - (2) Commit to a new term period,
 - (3) Arrange for a change of service, or
 - (4) Arrange for termination of the service.
- (B) In the event the customer does not select one of the above options, the customer will be converted to the shortest-term period available under tariff (i.e., month-to-month, one year, etc.) for the same service, and will be subject to the applicable term commitment, if any, unless the customer terminates the service within sixty (60) days of the conversion date.

FACILITIES FOR INTRASTATE ACCESS

2. GENERAL REGULATIONS (Cont'd)

2.8 Termination Liability (Cont'd)

2.8.4 Early Termination Liability

Early termination charges will not be assessed under the following circumstances:

- (A) Customer moves existing service either to a new location within the same address and/or same building (inside move) or to a new location (outside move) and maintains that service for the remainder of the term.

Customer attempts to move the existing service to a new location within Company's service area, but the service is unavailable;

- (B) Customer renegotiates a new term commitment plan for the same service before the current term commitment expires and the value of the new term commitment is equal to or greater than the remaining value of the current term commitment; or

- (C) Customer changes to another service or upgrades service to a higher speed or capacity under a term commitment, provided the following conditions are met:

- (1) The value of the new term commitment is equal to or greater than the remaining value of the current term commitment,
- (2) The Company provides the new service via tariff or on an individual case basis (ICB), and
- (3) The order to discontinue the existing service and the order for the new or upgraded service are received by the Company at the same time.

2.8.5 Termination Applicability

Rules and regulations set forth in 2.8.1, 2.8.2, 2.8.3 and 2.8.4 preceding affect only these services that reference this section for termination liability application. Termination liability as specified for other services shown elsewhere in the Company's tariffs applies in lieu of the above.

WN U-16
Zipty Fiber

Original Sheet 97

FACILITIES FOR INTRASTATE ACCESS

SECTION 3 TABLE OF CONTENTS

3. <u>ORDERING OPTIONS FOR FIA</u>	<u>Sheet No.</u>
3.1 <u>General</u>	98
3.1.1 Ordering Conditions	98
3.1.2 Provision of Other Services	105
3.1.3 Special Construction	105
3.1.4 Tandem Switch Signaling	105
3.2 <u>Access Service Request</u>	106
3.2.1 Service Date Intervals	106
3.2.2 ASR Modifications	106
(A) Service Date Change Charge	107
(B) Partial Cancellation Charge	107
(C) Discontinuance of Service	108
(D) Design Change Charge	108
(E) Expedited Order Charge	108
3.2.3 Selection of Facilities for Access Service	109
3.2.4 Minimum Period	109
3.2.5 Minimum Period Charges	110
3.2.6 Cancellation of an ASR	111
3.2.7 Discontinuance of Switched Access FGD or BSA-D	114
3.2.8 FGD and BSA-D Maximum Per Trunk Cancellation Charge	114
3.3 <u>Access Service Requests For Services Provided By More Than One Telephone Company</u>	115

WN U-16
Zipty Fiber

Original Sheet 98

FACILITIES FOR INTRASTATE ACCESS

3. ORDERING OPTIONS FOR FIA

3.1 General

This section sets forth the regulations and order related charges for ASRs to provide the customer with FIA. These charges are in addition to other applicable charges in other sections of this tariff.

3.1.1 Ordering Conditions

(A) A customer may order any amount of FIA (Switched or Special) of the same interface type, same Feature Group, same BSA or same Special Access between the same locations for installation on the same date on a single ASR. A customer may order the shared use of Switched Access and Special Access over the same high capacity facility however, separate ASRs are required. The methodology for shared use is in 5.6.7.

- ASRs for FGA or BSA-A must specify the number of lines required.
- ASRs for FGB, FGC, FGD, BSA-B, BSA-C, BSA-D and SAC Access Service must specify the number of trunks required or Busy Hour Minutes of Capacity (BHMC). For Tandem-Switched Transport, the customer has the option of specifying the number of trunks or Busy Hour Minutes of Capacity (BHMC).

In addition, the ASR must indicate whether the Switched Transport ordered is for Entrance Facilities, Direct-Trunked Transport and/or Tandem-Switched Transport. For Direct-Trunked Transport and Entrance Facilities the ASR must specify channel type, channel interface, and any options requested. ASRs for Direct-Trunked Transport must also specify Facility Hubs involved.

Additional ASR requirements for Switched Access Service are described in 4.2.5(U) and 4.3.2.

WN U-16
ZiPLY Fiber

Original Sheet 99

FACILITIES FOR INTRASTATE ACCESS

3. ORDERING OPTIONS FOR FIA (Cont'd)

3.1 General (Cont'd)

3.1.1 Ordering Conditions (Cont'd)

- (B) The customer shall supply all details necessary to complete an ASR. The details may include the following: requested service date, customer name, CDL, end office, Interface Arrangement, type of Switched Access or Special Access, Supplemental Features, End Office Services and Signaling Interface, and originating and terminating capacity required. The customer may also be required to provide end user name and location, end user contact person, and end user access hours to complete an ASR for Special Access.

When a customer orders mixed interstate and intrastate Switched Access, the customer is required to provide an estimate of the percent of traffic, as described in 4.3.3, which will be intrastate. If the customer fails to provide this estimate, the order will not be processed until such time as the customer provides this estimate.

When a customer orders mixed-use Special Access service, the customer must indicate the jurisdiction based on the criteria as in Section 5.1.6.

For Packet Switching Network Service, the packet switching carrier must provide a Percent Intrastate Usage (PIU) in the Main Remarks section of the ASR when service is initially ordered. This PIU will be used as the basis for prorating charges to the interstate and intrastate jurisdictions. The packet switching carrier may submit an updated PIU report in writing at any time following one full month's billing. The updated report will become effective on the first day of the next monthly billing period which begins at least 15 business days after the date the revised report is received by the Telephone Company.

- (C) When the Alternate Traffic Routing Optional Arrangement is ordered, more than one CDL will be supplied and the number of trunks or BHMC for FGB, FGC and FGD to each CDL shall be specified.

When the Alternate Traffic Routing Basic Serving Element (BSE) is offered, more than one CDL will be supplied and the number of trunks or BHMC for BSA-B, BSA-C and BSA-D to each CDL shall be specified.

WN U-16
Zipty Fiber

Original Sheet 100

FACILITIES FOR INTRASTATE ACCESS

3. ORDERING OPTIONS FOR FIA (Cont'd)

3.1 General (Cont'd)

3.1.1 Ordering Conditions (Cont'd)

(D) The customer shall order SAC Access Service, as described in 4.2.1(E), in the same manner specified for ordering FGD or BSA-D with the following exceptions. For 500 SAC Access Service or 900 SAC Access Service, customers may request direct connections to only those offices designated by the Telephone Company as 500 SAC Access Service or 900 SAC Access Service screening offices. All 500 NXX or 900 NXX Code assignments and administration shall be in accordance with the North American Numbering Plan (NANP). 800/877/888 SAC Access Service is offered only with the 800/877/888 Customer Identification Function as described in 4.2.10 and with 800/877/888 Data Base Query Service as described in 4.2.18. Customers may request 800/877/888 SAC access connections to suitably equipped end offices and access tandem offices. A list of those offices will be provided upon request. All 800/877/888 number assignments shall be administered by the Number Administration Service Center (NASC) through the Service Management System (SMS).

500 NXX codes or 900 NXX codes to be activated and/or deactivated with 500 SAC Access Service or 900 SAC Access Service, must be provided to the Telephone Company at least 30 business days prior to the effective date of the change.

An ASR is required by the Telephone Company for 500 NXX codes or 900 NXX codes to be activated or deactivated on an access facility level basis. The Switched Access Ordering Charge as described in 4.5.2(A)(3)(f) will apply. In addition to the Switched Access Ordering Charge, the NXX Translation Charge as described in 4.5.2(H)(8), shall apply to each 500 NXX code activated or deactivated in a Telephone Company switch capable of performing the customer identification function for 500 SAC Access Service. Customer assigned codes for which an ASR has not been received will be blocked.

When SAC Access Service is not terminated over a WATS Access Line described in 5.1.1, the customer must notify the Telephone Company of all local exchange telephone numbers to which SAC Access Service traffic is designated so that the Telephone Company can balance the end office in accordance with standard Telephone Company engineering practices for heavy volume lines.

WN U-16
ZiPLY Fiber

Original Sheet 101

FACILITIES FOR INTRASTATE ACCESS

3. ORDERING OPTIONS FOR FIA (Cont'd)

3.1 General (Cont'd)

3.1.1 Ordering Conditions (Cont'd)

- (E) To determine if adequate central office facilities (i.e., trunk circuits) for FGD or BSA-D will be available on the conversion date to equal access and to be eligible for the allocation as described in the following paragraph all customers (including those customers who convert existing FGA, FGB, FGC, BSA-A, BSA-B and BSA-C to FGD or to BSA-D) must order FGD or BSA-D 120 days prior to an end office conversion to equal access.

When trunk circuits are not available to meet the demand an allocation of available trunk circuits will be required. The allocation of available facilities is a three step process as described below:

In this example, assume nine ICs have ordered BHMCs which necessitate 1,000 FGD trunks where only 800 trunk circuits are available at the conversion date.

Step 1: Provide an initial flat 25% distribution of available trunk circuits to each requesting IC except for incremental requests over existing levels of FGC. (See table in Step 3.)

- $25\% \times 800$ (available facilities) - 200
- $\frac{200}{(9-1)} = 25$

Step 2: Assign all remaining trunk circuits proportionately, working from bottom up until ICs, as a result of the proration, are assigned less facilities than desired. First determine facilities available for apportionment.

- $800 - 175 = 625$ (eligible ICs are A, B, C, D, E, F)

- $\left(\frac{\text{Desired Facilities}}{\text{Total Desired Facilities}} \right) \times \frac{\text{Remaining Facilities}}{\text{of Remaining Facilities}}$

- $F = \frac{70}{1000 - 50} \times 625 = 46$ (assign only 45)(**)

- $E = \frac{80}{1000 - 120} \times (625 - 45) = 53$

(E receives less facilities than originally ordered, i.e., $53 + 25 = 78$)

WN U-16
ZiPLY Fiber

Original Sheet 102

FACILITIES FOR INTRASTATE ACCESS

3. ORDERING OPTIONS FOR FIA (Cont'd)

3.1 General (Cont'd)

3.1.1 Ordering Conditions (Cont'd)

(E) (Cont'd)

Step 3: When an IC receives less facilities than desired, the remaining ICs are allocated according to the following factor:

$$\frac{\text{Remaining Facilities}}{\text{Total Desired Facilities of Remaining Eligible ICs of Access}} = \frac{625 - 98}{1000 - 200} = \frac{527}{800} = .659$$

- IC #4 = 100 x .659 = 66
- IC #3 = 200 x .659 = 132
- IC #2 = 200 x .659 = 132
- IC #1 = 300 x .659 = 197

<u>Circuits</u>	<u>ICs</u>	<u>Demand Desired (In Trunks)</u>	<u>Resources Available</u>	<u>Step 1 Flat 25 Distribution</u>	<u>Step 2</u>	<u>Step 3</u>	<u>Total Assigned Trunk</u>
	A	300	-	25	-	197	222
	B	200	-	25	-	132	157
	C ¹	200	-	-0-	-	132	132
	D	100	-	25	-	66	91
	E	80	-	25	53	-	78
	F	70	-	25	45 ²	-	70
	G	25	-	25	-	-	25
	H	15	-	15 ²	-	-	15
	I	10	-	10 ²	-	-	10
	Total	1,000	800	175	98	527	800

¹ Request for additional trunk circuits by an IC with existing FGC or BSA-C.

² Will not assign more than desired.

WN U-16
ZiPLY Fiber

Original Sheet 103

FACILITIES FOR INTRASTATE ACCESS

3. ORDERING OPTIONS FOR FIA (Cont'd)

3.1 General (Cont'd)

3.1.1 Ordering Conditions (Cont'd)

- (F) The provision of Special Access requires the selection of a Terminating Option as defined in 5.3. The provision of Switched Access requires an Entrance Facility as defined in 4.2.3(B). When a customer orders DS3 SAL or a DS3 Switched Access Entrance Facility, he may specify, on the ASR, if the interface is to be an electrical or an optical interface. In the event the customer does not specify an interface preference for DS3, the Telephone Company will provide an electrical interface.

When a customer orders a FiberConnect SAL he must specify whether the interface is to be an electrical or optical termination and indicate the Network Channel Interface (NCI) code on the ASR. The customer must order FiberConnect as four DS1s.

When a customer orders DS3C Special Access, the Telephone Company will provide an optical interface unless service is provided via microwave, in which case an electro-magnetic interface is provided, or unless the customer specifies on the ASR a request for an electrical interface.

- (G) When ordering Operator Services, an ASR is required to establish a new FGC, FGD, BSA-C or BSA-D trunk group(s) or to add Operator Services to an existing FGC, FGD, BSA-C or BSA-D trunk group between the Telephone Company's Operator Services Switching Location and one CDL in the same LATA.

When measurement capability does not exist for Operator Services per call charges, a forecast of the number of Operator Services calls anticipated is required from the customer as described in 15.2.3(A) when the initial order for Operator Services is placed.

- (H) An ASR is required from the customer to add 1+ coin traffic from an end office. At the customer's option, the ASR can be issued at a 1+ coin tandem or end office level. For an initial customer order at a 1+ coin tandem, the Telephone Company must receive the request at least 120 calendar days prior to the requested effective date. Standard provisioning intervals will apply to subsequent orders involving that 1+ coin tandem.

The customer must provide the Telephone Company with written notification stating that an order is being submitted pursuant to an agreement with a secondary service provider prior to the routing of 1+ interLATA coin traffic to a provider other than the customer.

WN U-16
ZiPLY Fiber

Original Sheet 104

FACILITIES FOR INTRASTATE ACCESS

3. ORDERING OPTIONS FOR FIA (Cont'd)

3.1 General (Cont'd)

3.1.1 Ordering Conditions (Cont'd)

- (I) When ordering SS7 Out of Band Signaling as described in 4.2.5(W), the customer shall provide an ASR specifying a reference to existing CCS7 Access service facilities or a reference to a related ASR for CCS7 Access Service as described in ZiPLY Fiber Telephone Companies Tariff No. 3, Section 4.2.10. The customer's ASR shall also include STP point codes, STP location identifier codes, FGD or BSA-D trunk or 800/877/888 Service Access trunk circuit identification codes, and switch type. When ordering SS7 Out of Band Signaling for FGD or BSA-D, the customer shall specify that all traffic carried by that FGD or BSA-D will be equipped with out of band signaling. The customer shall work cooperatively with the Telephone Company to determine the number of CCS7 access service connections required to handle the customer's SS7 Out of Band Signaling traffic.

- (J) When a customer orders Tandem Switch Signaling (TSS), as described in 4.2.5(A)(A) and 4.2.20, to be established with the installation of a new FGD trunk group or 900 SAC Access Service trunk group, the Switched Access Ordering charge, per ASR and the appropriate Service Installation charge will apply for the installation of the FGD or 900 SAC Access services. TSS can only be provided from equal access end offices.

When a customer orders Tandem Switch Signaling to be added to an existing FGD trunk group, 900 SAC Access Service trunk group or to a pending ASR, only the Switched Access Ordering charge and the Design Change charge will apply for the addition of the optional arrangement.

WN U-16
ZiPLY Fiber

Original Sheet 105

FACILITIES FOR INTRASTATE ACCESS

3. ORDERING OPTIONS FOR FIA (Cont'd)

3.1 General (Cont'd)

3.1.1 Ordering Conditions (Cont'd)

- (K) When ordering FGD or BSA-D Switched Access with 950-XXXX Access as described in 4.2.5(T), the customer shall provide an ASR specifying which 950-XXXX access code(s) are to be routed and the FGD or BSA-D Switched Access Service over which resulting originating 950-XXXX access code calls are to be routed.
- (L) When ordering Carrier Identification Parameter (CIP) as described in 4.2.5 (A)(B), the customer shall provide an ASR specifying a reference to existing FGD or BSA-D switched access services or reference to a related ASR for FGD or BSA-D switched access services. The customer's ASR shall specify the information necessary to identify the trunk group to which the CIP is to be added.

3.1.2 Provision of Other Services

- (A) At the option of a customer, Recording and Processing, Additional Labor, Telecommunications Service Priority (TSP), Testing and Special Routing services may be ordered with an ASR at the same time the ASR is accepted by the Telephone Company. Such requests will be considered to be supplemental to the ASR. The rates and charges for these services as described in other sections of this tariff will apply in addition to the ordering charges specified in this section and the rates and charges for the Switched Access or Special Access with which they are associated.
- (B) The items listed in (A) may subsequently be added to the ASR at any time, up to and including the service date established by the ASR. When ordered subsequently, charges for ASR modifications as described in 3.2.2 will apply.

3.1.3 Special Construction

The regulations, rates and charges for Special Construction as described in Section 10 are in addition to the regulations, rates and charges specified in this section.

3.1.4 Tandem Switch Signaling

The regulations, rates and charges for Tandem Switch Signaling in Section 4 and 5 are in addition to the regulations, rates and charges specified in this section.

WN U-16
ZiPLY Fiber

Original Sheet 106

FACILITIES FOR INTRASTATE ACCESS

3. ORDERING OPTIONS FOR FIA (Cont'd)

3.2 Access Service Request

An ASR is used by the Telephone Company to order the following types of FIA requested by the customer:

- Switched Access as described in Section 4,
- Special Access as described in Section 5, and
- Other Services as described in other sections of the tariff.

3.2.1 Service Date Intervals

The time required to provision service is known as the service date interval. Such intervals will be established in accordance with published service date interval guidelines which are available to customers upon request. The service date interval guidelines will apply to ASRs and will specify the quantities of FIA that can be provided on the same service date. The customer may request a service date other than that established pursuant to the service date interval guidelines. The Telephone Company, where possible, will establish the service date in accordance with such request, subject to other applicable provisions of this tariff.

3.2.2 ASR Modifications

The customer may request a modification of its ASR prior to the service date. The Telephone Company will make every effort to accommodate a requested modification when it is able to do so with the normal work force assigned to complete such an ASR within normal business hours. If the modification cannot be made with the normal work force during normal business hours, the Telephone Company will notify the customer. If the customer still desires the ASR modification, the Telephone Company will schedule a new service date. All charges for ASR modifications will apply on a per occurrence basis. Where a new ASR may be required the appropriate charges as specified in other sections of this tariff will be applicable.

Any increase in the number of Switched Access lines for FGA or BSA-A, trunks or BHMCs for FGB, FGC, FGD, BSA-B, BSA-C, BSA-D and SAC Access Service or Special Access circuits will require the issuance of a new ASR for the incremental capacity.

WN U-16
Zipty Fiber

Original Sheet 107

FACILITIES FOR INTRASTATE ACCESS

3. ORDERING OPTIONS FOR FIA (Cont'd)

3.2 Access Service Request (Cont'd)

3.2.2 ASR Modifications (Cont'd)

(A) Service Date Change Charge

ASR service dates may be changed, however, a Service Date Change Charge will apply for each service date change after the Plant Test Date on the original ASR.

The new service date may not exceed the original service date by more than 30 days. If the requested service date is more than 30 days after the original service date, the ASR will be considered cancelled by the Telephone Company and cancellation charges as described in 3.2.6 will apply. A new ASR will be issued with the new service date.

With the agreement of the Telephone Company, a new service date may be established that is prior to the original service date and the provisions described in 3.2.2(E) will apply in addition to the Service Date Change Charge.

	<u>Rate</u>
Service Date Change Charge (SUM)	\$66.50

(B) Partial Cancellation Charge

Any decrease in the number of Switched Access lines for FGA or BSA; or BHMC for FGB, FGC, FGD, BSA-B, BSA-C, BSA-D and SAC Access Service, or Special Access circuits will be treated as a partial cancellation.

A customer may cancel any number of Special Access circuits.

When a customer partially cancels the service ordered on an ASR, charges will apply as follows:

- (1) Except as specified in 3.2.6(D), when an ASR for Switched Access or Special Access Service is partially canceled on or after the Application Date, the charge will be determined by multiplying the total Installation nonrecurring charges for the canceled portion of the order by the number of business days that have elapsed since the Application Date and dividing that figure by the number of days in the service interval and adding the Switched Access or Special Access Ordering Charge.
- (2) When a customer cancels part of an ASR for which billing has commenced as provided in 3.2.6(A), cancellation charges in 3.2.6(C)(2) will apply to that part of the ASR being canceled.
- (3) When an ASR for Special Access Service is partially canceled on or after the Plant Test Date, the Initial and Subsequent Ordering Charges as described preceding will apply, plus the Installation Charge(s) associated with the items canceled.

FACILITIES FOR INTRASTATE ACCESS

3. ORDERING OPTIONS FOR FIA (Cont'd)3.2 Access Service Request (Cont'd)3.2.2 ASR Modifications (Cont'd)(C) Discontinuance of Service

A customer may discontinue FIA that is in service at any time. The request for discontinuance of service must be received by the Telephone Company at least two business days prior to the date on which service is to be disconnected and billing discontinued. The request may be verbal or written, however, a verbal request must be followed, within ten days, by written confirmation. The written confirmation serves as a confirmation of the verbal request rather than a request itself. The customer must notify the Telephone Company of a delay or cancellation in the discontinuance request prior to the disconnect date. The Telephone Company, where possible, will establish the disconnect date in accordance with such a request. Billing and service will then continue until the new requested disconnect date. If a service is discontinued prior to the expiration of the Minimum Period in 3.2.4, the Minimum Period Charges in 3.2.5, may apply.

(D) Design Change Charge

The customer may request a design change to a pending ASR for both Switched and Special Access or request a change to an existing Switched Access Service. A design change is a change which requires engineering review. The regulations, rates and charges for a design change are in Section 4.5.2(A)(3)(h) for Switched Access Service, and Section 5.6.1(D)(3) for Special Access Service, and are in addition to the regulations, rates and charges specified in this section.

(E) Expedited Order Charge

When placing an Access Service Request a customer may request a service date that is prior to the Telephone Company's published service date interval. If the Telephone Company determines that the service can be provided on the requested date, an Expedited Order Charge will apply.

A customer may also request an earlier service date on a pending Access Service Request. If the customer's request can be accommodated, a Service Date Change Charge as described in Section 3.2.2 (A) will apply in addition to the Expedited Order Charge.

If the Telephone Company is subsequently unable to meet an agreed upon expedited service date, the Expedited Order Charge will not apply.

In the event that the Telephone Company provides service on an expedited basis by customer request and the customer then delays service, an additional Service Date Change Charge as described in Section 3.2.2 (A) will apply.

The Expedited Order Charge applies per order, based on the requested service date. A request to expedite service to be available the next day is a one day expedite, a request for service in two days is a two day expedite, and so on to a request for service a week from the request date is a seven day expedite. Expedited orders for same day service are not available. If the requested service date is at the published service date interval or later, no Expedited Order Charge will apply.

WN U-16
Zipty Fiber

Original Sheet 109

FACILITIES FOR INTRASTATE ACCESS

3. ORDERING OPTIONS FOR FIA (Cont'd)

3.2 Access Service Request (Cont'd)

3.2.2 ASR Modifications (Cont'd)

(E) Expedited Order Charge (Cont'd)

Rates for Expedited Order Charges are as follows:

	<u>Charge</u>
One Day Expedite	\$495.00
Two Day Expedite	484.00
Three Day Expedite	462.00
Four Day Expedite	411.00
Five Day Expedite	436.00
Six Day Expedite	432.00
Seven Day Expedite	428.00
Eight Day Expedite	428.00
Nine Day Expedite	428.00

3.2.3 Selection of Facilities for Access Service

(A) Requests for a specific circuit is not an option of the customer except as provided for under Special Facilities Routing of FIA in Section 9.

3.2.4 Minimum Period

(A) The Minimum Period for which Special Access, Packet Switching Network Service, and Basic Service Elements (BSEs) are provided and for which charges are applicable, is one month, except as in (D).

(B) The Minimum Period for Miscellaneous Services is in Section 6.

(C) The Minimum Period for Temporary Videoband and Program Audio Special Access is the minimum period for which rates are established in Sections 5.7 and 5.8.

(D) The Minimum Period for FIA provided under Special Construction provisions and for which charges are applicable is in Section 10.

(E) The Minimum Period for FGA, FGB, FGC, BSA-A, BSA-B, BSA-C, SAC Access Service, and also for FGD or BSA-D ordered after the conversion of an end office to equal access is one month. For the application of the minimum period charges for Switched Access Service FGB, FGC, BSA-A, BSA-B, BSA-C, SAC Access Service, and for FGD or BSA-D ordered after the conversion of an end office to equal access, it is assumed the last identical capacity placed in service is the first one discontinued.

(F) For FGD or BSA-D ordered prior to the conversion of an end office to equal access and (1) canceled prior to the conversion date, a Cancellation Charge in 3.2.6 applies or (2) canceled on or after the equal access conversion date, a Discontinuance Charge in 3.2.7 applies.

FACILITIES FOR INTRASTATE ACCESS

3. ORDERING OPTIONS FOR FIA (Cont'd)

3.2 Access Service Request (Cont'd)

3.2.5 Minimum Period Charges

When FIA are discontinued prior to the expiration of the Minimum Period, charges are applicable for the remaining month(s) and/or fraction thereof of the Minimum Period.

The Minimum Period Charge will be determined as follows:

- (A) For Switched Access usage sensitive rate elements, the charge for the minimum period, or fraction thereof, is equal to the applicable rates for the actual or assumed usage for the minimum period or such fraction thereof. For Switched Access flat-rated monthly elements (i.e., Entrance Facility, Direct Trunked Transport and Multiplexing rates), the charge for the minimum period or fraction thereof is the applicable monthly rates for the service.
- (B) For Special Access, the charge is the applicable monthly rate for service(s) in 5.7. For Special Access DS3 Service, the charges are found in Section 5.6.11.
- (C) For FGD or BSA-D ordered prior to conversion of an end office to equal access, but canceled after the equal access conversion date, discontinuance charges in 3.2.7 will apply.
- (D) For part-time or occasional Program Audio Special Access services, the rates in 5.6.1, 5.7 and 5.8 will apply.

FACILITIES FOR INTRASTATE ACCESS

3. ORDERING OPTIONS FOR FIA (Cont'd)

3.2 Access Service Request (Cont'd)

3.2.6 Cancellation of an ASR

- (A) A customer may cancel ordered FIA on any date prior to the service date. The cancellation date is the date the Telephone Company receives written or verbal notice from the customer that the ASR is to be canceled. The verbal notice must be followed by written confirmation within 10 days.

For Switched Access Tandem-Switched Transport or ASRs requesting additional trunk activation on existing Direct-Trunked Transport facilities, if a customer is unable to accept service within 30 calendar days of the original service date, the ASR shall be considered canceled and charges in (C) and (D) will apply. In such instances, the cancellation date shall be the 31st calendar day beyond the original service date of the ASR.

For Special Access if a customer is unable to accept service within 30 calendar days of the original service date, the customer has the choice of the following options:

- The ASR shall be canceled and charges in (C) will apply, or
- Billing for the service will commence.

In either case, the cancellation date or the billing date shall commence on the 31st calendar day beyond the original service date of the ASR.

- (B) ASR costs are considered to have started when the Telephone Company incurs any cost in connection therewith or in preparation thereof which would not otherwise have been incurred. These costs include but are not limited to preliminary engineering, orders to suppliers, and other similar items of cost. For purposes of determining cancellation charges, costs are considered to have started the day the Telephone Company receives the confirmed ASR. For all ASRs this is known as the Application Date.

The cancellation charges will not apply until the customer is notified of such charges.

WN U-16
ZiPLY Fiber

Original Sheet 112

FACILITIES FOR INTRASTATE ACCESS

3. ORDERING OPTIONS FOR FIA (Cont'd)

3.2 Access Service Request (Cont'd)

3.2.6 Cancellation of an ASR (Cont'd)

(C) When a customer cancels an ASR for the installation of new service, or an ASR to modify existing service, charges will apply as follows:

- (1) When an ASR for Switched Access or Special Access Service is canceled on or after the Application Date, the Cancellation Charge is calculated, on a per ASR basis, by multiplying the total Installation nonrecurring charges for the quantity ordered by the number of business days elapsed since the Application Date, and dividing that figure by the number of days in the service interval. This corresponds to the number of business days between the Application Date and the last day of the service date interval. The Switched Access Ordering Charge or Special Access Initial and Subsequent Order Charge will also be applied.
- (2) When a customer chooses to commence billing rather than cancel an ASR for the services specified in (A), the customer must submit an ASR prior to calendar day 31 from the original service date and request a service date change. The new service date may not exceed the original service date by more than 120 calendar days. Charges in 3.2.2(A) will only apply for each subsequent service date change request after calendar day 31, not to exceed 120 calendar days.

When a customer elects to commence billing, monthly recurring charges will begin accruing at calendar day 31 after the original service date. Upon completion of the ASR, the initial bill for the service will include these accrued charges and any additional nonrecurring charges in addition to billable charges specified in 2.4.1(C).

WN U-16
Zipty Fiber

Original Sheet 113

FACILITIES FOR INTRASTATE ACCESS

3. ORDERING OPTIONS FOR FIA (Cont'd)

3.2 Access Service Request (Cont'd)

3.2.6 Cancellation of an ASR (Cont'd)

(D) If the Special Access ASR is not completed within 121 calendar days of the original service date, the ASR is canceled. Cancellation charges in 3.2.6(C)(1) will apply. In addition, the customer will be billed the accrued monthly recurring charges specified above plus any additional nonrecurring charges applicable for the service. These charges will be computed commencing at day 31 after the original service date up to and including the cancellation date, not to exceed 90 days of service (120 from the original service date). The Telephone Company will not reissue an ASR with a new service date beyond 121 calendar days. It will be the customer's responsibility to submit a new ASR for Switched or Special Access Service, as appropriate.

For cancellation of an ASR for Switched Access FGD or BSA-D before an end office converts to equal access, cancellation charges will apply if the Telephone Company is notified of the cancellation within a period of 12 months prior to the scheduled service date. Cancellation charges apply to each trunk canceled.

When (due to a shortage of FGD or BSA-D facilities) an allocation of FGD or BSA-D facilities is made, cancellation charges apply only to circuits allocated to the customer.

Cancellation charges will accrue to the maximum in equal monthly increments (i.e., maximum cancellation charge divided by 12) beginning twelve months before an end office converts to equal access. Maximum cancellation charges are listed in 3.2.8. The charge applied will be the accrued charge in the month during which notice of cancellation is received by the Telephone Company.

<u>Month During Which Notice Is Received Before Conversion Date</u>	<u>Charge (Per Trunk Canceled)</u>
12	\$32.67
11	65.35
10	98.02
9	130.70
8	163.37
7	196.05
6	228.72
5	261.39
4	294.07
3	326.74
2	359.42
1	392.09

WN U-16
ZiPLY Fiber

Original Sheet 114

FACILITIES FOR INTRASTATE ACCESS

3. ORDERING OPTIONS FOR FIA (Cont'd)

3.2 Access Service Request (Cont'd)

3.2.7 Discontinuance of Switched Access FGD or BSA-D

A Discontinuance Charge applies if a customer discontinues FGD or BSA-D service provided at the conversion of an end office to equal access. The Discontinuance Charge applies to each FGD or BSA-D trunk discontinued. For purposes of calculating the Discontinuance Charge the Maximum Discontinuance Charge will be amortized in equal monthly increments (i.e., Maximum Discontinuance Charge divided by 12) over a 12 month period beginning on the date the end office converts to equal access. The Maximum Discontinuance Charge is equal to the FGD or BSA-D Maximum Cancellation Charge in 3.2.8. The charge assessed will be the unamortized portion of the Maximum Discontinuance Charge.

<u>Month During Which Service is Discontinued After Conversion Date</u>	<u>Charge (Per Trunk Discontinued)</u>
1	\$392.09
2	359.42
3	326.74
4	294.07
5	261.39
6	228.72
7	196.05
8	163.37
9	130.70
10	98.02
11	65.35
12	32.67

3.2.8 <u>FGD or BSA-D Maximum Per Trunk Cancellation Charge</u>	<u>Rate</u>
Cancellation Charge	\$392.09

WN U-16
ZiPLY Fiber

Original Sheet 115

FACILITIES FOR INTRASTATE ACCESS

3. ORDERING OPTIONS FOR FIA (Cont'd)

3.3 Access Service Requests for Services Provided By More Than One Telephone Company

- (A) Switched or Special Access Services provided by more than one telephone company are services where one end of the Switched Transport or Special Transport facility is in the operating territory of one telephone company and the other end of the facility is in the operating territory of a different telephone company.

The ordering procedure for this service is in (1) and (2). The telephone company will notify the customer, identifying which ordering procedures will apply.

(1) Single Company Billing

The telephone company receiving the ASR from the customer will arrange to provide the service and bill the customer as described in 2.7.2. The customer will place the ASR with the telephone company as follows:

- (a) For Switched Access Services the customer will place the ASR with the telephone company in whole territory the following is located.

- FGA – dial tone office

When the preceding is not in the same telephone company's territory as the customer designated location (CDL), the customer must supply a copy of the ASR to the telephone company in whose territory the CDL is located.

(2) Meet Point Billing

Each telephone company will provide its portion of the Switched Transport or Special Transport Service within its operating territory to the meet point with the other telephone company(s). The BP will be determined by the telephone companies involved in providing the FIA service and listed in the NECA Tariff FCC No. 4.

For all Switched Access Services and Special Access Services the order will be placed with the telephone company based upon industry guidelines.

FACILITIES FOR INTRASTATE ACCESS

SECTION 4 TABLE OF CONTENTS

4. <u>SWITCHED ACCESS</u>	<u>Sheet No.</u>
4.1 <u>General</u>	124
4.2 <u>Description of Switched Access</u>	125
4.2.1 <u>Description of Feature Groups</u>	126
(A) <u>Feature Group A</u>	126
(B) <u>Feature Group B</u>	130
(C) <u>Feature Group C</u>	134
(D) <u>Feature Group D</u>	139
(E) <u>SAC Access Service</u>	145
4.2.2 <u>Description of Basic Serving Arrangements (BSAs)</u>	148
(A) <u>BSA-A</u>	148
(B) <u>BSA-B</u>	153
(C) <u>BSA-C</u>	158
(D) <u>BSA-D</u>	164
(E) <u>Dedicated Network Access Link (DNAL)</u>	170
4.2.3 <u>Description of Switched Transport</u>	171
(A) <u>General</u>	171
(B) <u>Entrance Facilities</u>	174
(1) <u>Two-Wire Voice Frequency Entrance Facility</u>	174
(2) <u>Four-Wire Voice Frequency Entrance Facility</u>	175
(3) <u>Group Analog Entrance Facility</u>	176
(4) <u>Supergroup Analog Entrance Facility</u>	176
(5) <u>Mastergroup Analog Entrance Facility</u>	177
(6) <u>DS1 Digital Entrance Facility</u>	177
(7) <u>DS1C Digital Entrance Facility</u>	178
(8) <u>DS2 Digital Entrance Facility</u>	178
(9) <u>DS3 Digital Entrance Facility</u>	178
(10) <u>DS3C Digital Entrance Facility</u>	179
(C) <u>Direct-Trunked Transport</u>	180
(D) <u>Tandem-Switched Transport</u>	181
(E) <u>Interconnection Rate</u>	181
(F) <u>Multiplexing Arrangement</u>	182
(G) <u>Optional Arrangements</u>	182

WN U-16
ZiPLY Fiber

Original Sheet 117

FACILITIES FOR INTRASTATE ACCESS

SECTION 4 TABLE OF CONTENTS

4.	<u>SWITCHED ACCESS</u> (Cont'd)	<u>Sheet No.</u>
4.2	<u>Description of Switched Access</u> (Cont'd)	
4.2.4	Description of End Office Services	184
4.2.5	End Office Services Optional Arrangements.....	185
	(A) Alternate Traffic Routing	185
	(B) Automatic Number Identification (ANI) Arrangement.....	186
	(C) Intra Access Area Call Denial on Line or Hunt Group	188
	(D) InterLATA Call Denial on Line or Hunt Group	189
	(E) Call Denial on Line or Hunt Group Outside of the Access Area.....	189
	(F) Dual Tone Multifrequency Address Signaling	190
	(G) Hunt Group Arrangement.....	190
	(H) Customer Specification of Switched Access Directionality.....	190
	(I) Nonhunting Number for Use with Hunt Group Arrangement.....	190
	(J) Nonhunting Number for Use with Uniform Call Distribution Arrangement.....	191
	(K) Operator Assistance Full Feature Arrangement	191
	(L) Rotary Dial Station Signaling	191
	(M) Service Class Routing.....	191
	(N) Service Code Denial on Line or Hunt Group.....	192

FACILITIES FOR INTRASTATE ACCESS

SECTION 4 TABLE OF CONTENTS

4. <u>SWITCHED ACCESS</u> (Cont'd)	<u>Sheet No.</u>
4.2 <u>Description of Switched Access</u> (Cont'd)	
4.2.5 End Office Services Optional Arrangements (Cont'd)	
(O) Trunk Access Limitation.....	192
(P) Uniform Call Distribution Arrangement.....	192
(Q) Up to Seven Digit Outpulsing of Access Digits to the Customer .	192
(R) Band Advance Arrangement.....	192
(S) FGD and BSA-D Switched Access with 950-XXXX Access	193
(T) Operator Assistance for SAC Access Services	193
(U) Switched Access Interface.....	193
(V) Switched Data Service.....	201
(1) Switched 56.....	201
(2) Switched 64.....	201
(W) Signaling System 7 (SS7) Out of Band Signaling	202
(X) Calling Party Number (CPN) Parameter.....	202
(Y) Carrier Selection Parameter (CSP).....	202
(Z) Charge Number (CN) Parameter.....	203
(A)(A) Tandem Switch Signaling	204
(A)(B) Carrier Identification Parameter (CIP)	204
4.2.6 Call Restriction and Code Screening Reports	205
4.2.7 Installation and Acceptance Testing of Switched Access.....	205
4.2.8 Provision of Design Layout Report	205
4.2.9 Network Management.....	206
4.2.10 800/877/888 Customer Identification Function.....	206
4.2.11 900 Customer Identification Function	206
4.2.12 Design and Routing of Switched Access	206
4.2.13 Provision of Switched Access Performance Data	207
4.2.14 Transmission Performance	207
4.2.15 Design Blocking Probability.....	207
4.2.16 Special Facilities Routing.....	210
4.2.17 Information Surcharge	210
4.2.18 800/877/888 Data Base Query Service	210
4.2.19 500 Customer Identification Function	210
4.2.20 Tandem Switch Signaling.....	210
4.2.21 Basic Service Elements (BSEs)	211
4.2.22 IntraLATA Equal Access Recovery Charge	219

FACILITIES FOR INTRASTATE ACCESS

SECTION 4 TABLE OF CONTENTS

4.	<u>SWITCHED ACCESS</u> (Cont'd)	<u>Sheet No.</u>
4.3	<u>Obligations of the Customer</u>	220
4.3.1	On and Off-Hook Supervision	220
4.3.2	ASR Requirements	220
4.3.3	Jurisdictional Report Requirements.....	221
	(A) Jurisdictional Reports.....	221
	(B) Maintenance of Customer Records.....	226
	(C) Jurisdictional Reports Verification.....	227
	(D) Contested Jurisdictional Reports.....	228
4.4	<u>Payment Arrangements and Credit Allowances</u>	231
4.4.1	Cancellation of Applications	231
4.4.2	Credit Allowances	231
4.5	<u>Rate and Charge Regulations</u>	231
4.5.1	Rate Elements	231
4.5.2	Rate Regulations	232
	(A) Types of Rates and Charges.....	232
	(1) Usage Rates.....	232
	(2) Flat Rated.....	232
	(3) Nonrecurring Charges.....	233
	(a) Service Installation Charges	233
	(b) Installation of Voiceband Entrance Facilities	233
	(c) Installation of Multiplexing Arrangements	233
	(d) Installation of DS1 and DS3 Entrance Facilities.....	233
	(1) DS1 Standard Arrangements	233
	(2) DS1 Optional Payment Plan (OPP) Arrangement	234
	(3) DS3 Arrangements	234
	(e) Switched Access Installation Charge Waiver	235
	(f) Switched Access Ordering Charges	235
	(g) Service Rearrangements	237
	(h) Design Change Charge.....	246

FACILITIES FOR INTRASTATE ACCESS

SECTION 4 TABLE OF CONTENTS

4.	<u>SWITCHED ACCESS</u> (Cont'd)	<u>Sheet No.</u>
4.5	<u>Rate and Charge Regulations</u> (Cont'd)	
4.5.2	Rate Regulations (Cont'd)	
	(A) Types of Rates and Charges (Cont'd)	
	(3) Nonrecurring Charges (Cont'd)	
	(i) Installation Charge for FGA and BSA-A Optional	
	Toll Blocking Arrangements	246
	(j) Change of Switched Access Type	247
	(k) Moves.....	250
	(1) Same CDL.....	250
	(2) A Different CDL	250
	(B) 800/877/888 Data Base Query Service.....	250
	(C) Network Blocking Charge for Tandem-Switched FGB, FGC, FGD, BSA-B, BSA-C, BSA-D and SAC Access Service	251
	(D) Determination of Intrastate Charges for Mixed Interstate and Intrastate Switched Access	252
	(E) Local Dial-It Services.....	252
	(F) Local Directory Assistance.....	252
	(G) Signaling System 7 (SS7) Out of Band Signaling	252

FACILITIES FOR INTRASTATE ACCESS

SECTION 4 TABLE OF CONTENTS

4.	<u>SWITCHED ACCESS</u> (Cont'd)	<u>Sheet No.</u>
4.5	<u>Rate and Charge Regulations</u> (Cont'd)	
4.5.2	Rate Regulations (Cont'd)	
	(H) Description and Application of Rates.....	253
	(1) Determination of Premium Rates and Nonpremium Rates .	253
	(2) Switched Transport.....	254
	(3) Extended FGA and BSA-A Terminating Traffic.....	259
	(4) Equal Access Notification.....	260
	(5) End Office Switching	262
	(6) Transitional Billing Arrangements	262
	(7) Tandem Switch Signaling (TSS)	265
	(8) NXX Translation Nonrecurring Charge	266
	(I) Measuring Access Minutes	267
	(1) FGA and BSA-A Usage Measurements.....	268
	(2) FGB and BSA-B Usage Measurements.....	269
	(3) Usage Measurement Not Available For FGA, FGB, BSA-A and BSA-B.....	269
	(4) FGC and BSA-C Usage Measurement	270
	(5) FGD and BSA-D Usage Measurement	272
	(6) SAC Access Service Usage Measurement.....	273
	(J) FGD and BSA-D Switched Access Service with 950-XXXX.....	273
4.5.3	Switched Access Zone Density Rate Plan	273
4.5.4	Application of Rates for FGA and BSA-A Extension Service	275
4.5.5	Switched Access DS1 Optional Payment Plan (OPP).....	276
4.5.6	Switched Access DS1 Term Payment Plan.....	281
4.5.7	Switched Access DS3 Term Payment Plan.....	286
4.5.8	Shared Use Analog and Digital High Capacity Services	292
4.5.9	Basic Service Elements (BSEs).....	293
	(A) Alternate Traffic Routing - BSE.....	293
	(B) Automatic Number Identification (ANI) - BSE	293
	(C) User Transfer - BSE.....	293
	(D) Hunt Group Arrangement - BSE	293
	(E) Queuing - BSE	293
	(F) Uniform Call Distribution - BSE.....	294
	(G) Simplified Message Desk Interface (SMDI) - BSE.....	294
	(H) Remote Call Forwarding - BSE.....	294
	(I) Direct Inward Dialing (DID) - BSE.....	294
	(J) Billing Number Screening (BNS) - BSE	294

WN U-16
ZiPLY Fiber

Original Sheet 122

FACILITIES FOR INTRASTATE ACCESS

SECTION 4 TABLE OF CONTENTS

4. <u>SWITCHED ACCESS</u> (Cont'd)	<u>Sheet No.</u>
4.6 <u>Rates and Charges</u>	295
4.6.1 Nonrecurring Charges.....	295
(A) Switched Access Service Ordering Charges	295
(B) 500 NXX Translation Charge	295
(C) Network Blocking Charge	295
(D) FGA and BSA-A Optional Toll Blocking.....	295
4.6.2 Switched Transport.....	296
(A) Tandem-Switched Transport - Facility	296
(B) Tandem-Switched Transport - Termination.....	296
(C) Tandem Switching Rate	296
(D) Direct-Trunked Transport - Voiceband	297
(E) Direct-Trunked Transport - DS1	297
(F) Direct-Trunked Transport - DS3	297
(G) Entrance Facility - 2 Wire and 4-Wire Voiceband.....	298
(H) Entrance Facility - DS1	298
(I) Entrance Facility - DS3	299
(J) Multiplexing	299
(K) Entrance Facility - DS1 - Optional Payment Plan (Discounted Rate).....	300
(L) Entrance Facility - DS1 - Term Payment Plan (Discounted Rate).....	301
(M) Entrance Facility - DS3 - Term Payment Plan (Discounted Rate).....	302
(N) Interconnection Rate.....	306

WN U-16
Zipty Fiber

Original Sheet 123

FACILITIES FOR INTRASTATE ACCESS

SECTION 4 TABLE OF CONTENTS

4.	<u>SWITCHED ACCESS</u> (Cont'd)	<u>Sheet No.</u>
4.6	<u>Rates and Charges</u> (Cont'd)	
4.6.3	End Office Services.....	307
	(A) End Office Switching – Bundled (EOSB)	307
	(B) End Office Switching – Unbundled (EOSU)	307
	(C) Alternate Routing - BSE	307
	(D) Automatic Number Identification (ANI) - BSE	308
	(E) User Transfer – BSE.....	308
	(F) Queuing - BSE.....	308
	(G) Uniform Call Distribution - BSE	308
	(H) Simplified Message Desk Interface (SMDI) - BSE	308
4.6.4	Information Surcharge.....	309
4.6.5	IntraLATA Equal Access Recovery Charge.....	309
4.6.6	Line Extension Rate Additive.....	309
4.6.7	Carrier Identification Parameter (CIP).....	309

FACILITIES FOR INTRASTATE ACCESS

4. SWITCHED ACCESS4.1 General

Switched Access provides two-point communications paths between the point of termination at a CDL and the points of termination at Telephone Company end user premises within the Access Area. Each path is established through the use of Switched Transport, End Office Services, and Common Lines. Switched Access provides for the ability to originate calls from an end user's premises to the CDL and to terminate calls from the CDL to an end user's premises. Specific descriptions of Switched Access are in 4.2.

Switched Access services, when used to provide Tandem Switch Signaling (TSS) may be connected to a customer's access tandem via Switched Transport Access services or to a customer's transmission equipment and facilities using a DS1 or DS3 Cross Connect arrangement where the customer is provided Expanded Interconnection Service per a collocation arrangement. TSS is available only with FGD, and BSA-D Switched Access, 500 SAC Access and 900 SAC Access services provided from equal access end offices. TSS is provided in multifrequency (MF) address signaling format from equal access end offices. TSS is also provided in SS7 Out of Band signaling format at suitably equipped (Service Switching Point) end offices. TSS is not available from end offices that use alternate technologies to provide equal access capabilities, nor from Telephone Company access tandems.

Switched Access Feature Groups are ordered in either quantities of lines or in Busy Hour Minutes of Capacity (BHMC). FGA and BSA-A are furnished on a per-line basis, and FGB, FGC, FGD, BSA-B, BSA-C, BSA-D and SAC Access Service are furnished on a per-trunk basis in accordance with the capacity ordered in BHMC.

Quantities of lines, or total BHMC of the circuit group connecting the first point of switching and the CDL are determined at the Telephone Company's first point of switching.

A customer may designate one or more CDLs within the LATA for FGA, FGB, FGC, FGD, BSA-A, BSA-B, BSA-C, BSA-D Switched Access or SAC Access Service except that in the case of 800/877/888 SAC Access Service, customers may request connections only to suitably equipped end offices and access tandem offices as discussed in 3.1.1(D).

When Switched Access is ordered in BHMC, the BHMC must be differentiated by Feature Group type and directionality of traffic as in 4.3.2 in order for the Telephone Company to properly design Switched Access to meet the traffic carrying capacity requirements of the customer.

When a customer plans to use Switched Access in connection with the resale of services of an IC, the provisions for such Switched Access charges are in Section 12.

Switched Access is provided with basic testing as described in 4.2.1(A)(9), (B)(10), (C)(10), (D)(10), and 4.2.7. Additional testing is provided as described in 6.6. Testing is provided only on the FIA supplied by the Telephone Company.

Shared use between Switched Access and Special Access over high capacity facilities is described in 5.6.7.

Switched Access may be ordered by the customer for mixed intrastate and interstate communications as described in 4.3.2 and 4.5.2.

FACILITIES FOR INTRASTATE ACCESS

4. SWITCHED ACCESS (Cont'd)4.2 Description of Switched Access

Switched Access is provided in conjunction with either of two types of access services, bundled Feature Groups or unbundled Basic Serving Arrangements (BSAs). BSAs, described in 4.2.2, are provided in two basic categories differentiated by their technical characteristics and how they connect, line side or trunk side connection, to the Telephone Company's first point of switching. The trunk side BSA is further differentiated into three alternatives based upon how the end user accesses the trunk side BSA, with or without an access code. Feature Group A (FGA) and Basic Serving Arrangement A (BSA-A) are defined as line side connections to the Telephone Company's network. Feature Group B (FGB), Feature Group C (FGC), Feature Group D (FGD), Basic Serving Arrangement Alternative B (BSA-B), Basic Serving Arrangement Alternative C (BSA-C), and Basic Serving Arrangement Alternative D (BSA-D) are defined as trunk side connections to the Telephone Company's network. The use of a line side or trunk side switched access connection is dependent upon the switched access arrangement ordered by the customer. Feature Groups and BSAs are arranged for either originating, terminating, or two-way calling, based on the end office switching capacity ordered. Originating calling permits the delivery of calls from Telephone Company exchange service locations to the customer's premises. Terminating calling permits the delivery of calls from the customer's premises to Telephone Company exchange service locations. Two-Way calling permits the delivery of calls in both directions, but not simultaneously.

Switched Access will be provided as both Feature Groups and BSAs to Telephone Company end offices either directly routed or routed via an access tandem, except as set forth following:

- Feature Group and BSA trunk side equivalents (FGB and BSA-B, FGC and BSA-C, and FGD and BSA-D) may not be provided for the same Carrier Identification Code (CIC) at Telephone Company end offices which subtend the same tandem. When a Telephone Company end office subtends multiple tandems, Feature Group and BSA trunk side equivalents may not be provided for the same CIC at any Telephone Company end office which subtends either tandem.
- Feature Group and BSA line side equivalents (FGA and BSA-A) may not be mixed in the same multiline hunt group.

WN U-16
Zipty Fiber

Original Sheet 126

FACILITIES FOR INTASTATE ACCESS

4. SWITCHED ACCESS (Cont'd)

4.2 Description of Switched Access

4.2.1 Description of Feature Groups

The Telephone Company, under the ordering provisions in Section 3, at rates and charges as specified in 4.6, will provide Switched Access Feature Groups as follows:

(A) Feature Group A

Feature Group A (FGA), which is available to all customers, provides line-side access to Telephone Company end office switches with an end user access code of NXX-XXXX for the customer's use in originating and terminating communications. FGA is available as Message Telecommunications Service-type or Wide Area Telecommunications Service-type (MTS/WATS-type) access or as Foreign Central Office/Off Network Access Line (FCO/ONAL) open end access, for customer provided intrastate communications capability or connection to an interexchange intrastate service.

- (1) FGA is provided at all Telephone Company end office switches and switches customer communications to and from Common Lines or Special Access Lines, as described in 4.2.1(A).

FGA utilizes a two-point electrical communications path between the Interface Arrangement and the Common Line which is a voice grade transmission path comprised of any form or configuration of plant capable of, and typically used in the telecommunications industry for, the transmission of the human voice and associated telephone signals within the frequency bandwidth of approximately 300 to 3000 Hz.

- (2) FGA is provided as line side switching through end office switch line equipment. Line side switching may, at the option of the customer, be provided with ground start supervisory signaling or loop start supervisory signaling.
 - (3) The customer shall select the first point of switching, within the selected FGA Access Area.
 - (4) FGA is arranged for originating calling only, terminating calling only or two-way calling. The Telephone Company will determine the type of calling to be provided unless the customer requests the option, Customer Specification of Switched Access Directionality as described in 4.2.5(H). For such specification, additional charges on an Individual Case Basis will apply if the calling arrangements are different than that the Telephone Company would have provided without such special arrangements. Originating calling permits the origination of calls from the end user to the CDL. Terminating calling permits the termination of calls from the CDL to the end user. Two-way calling permits either the origination or termination of calls, but not simultaneously.
-

WN U-16
Ziplay Fiber

Original Sheet 127

FACILITIES FOR INTRASTATE ACCESS

4. SWITCHED ACCESS (Cont'd)

4.2 Description of Switched Access (Cont'd)

4.2.1 Description of Feature Groups

(A) Feature Group A (Cont'd)

- (5) FGA, when being used in the terminating direction, is arranged with dial tone start-dial signaling and dial pulse address signaling. FGA, when being used in the terminating direction, may, at the option of the customer, be arranged for Dual Tone Multifrequency (DTMF) address signaling, subject to availability of equipment in the end office from which FGA is provided. When FGA is provided in a Hunt Group Arrangement or Uniform Call Distribution Arrangement, all FGA will be arranged for the same type of signaling.

No address signaling is provided by the Telephone Company when FGA is used in the originating direction. Address signaling in such cases, if required by the customer, must be provided by the end user using inband tone signaling techniques. Such inband tone address signals will be subject to the ordinary transmission capabilities of the Switched Transport provided.

- (6) FGA, when being used in the terminating direction, may be used to access valid NXXs in the FGA Access Area. For FGA, the Access Area is defined as the local calling area of the end office switch from which the FGA is provided. The description of any specific FGA Access Area will be provided to the customer upon request. Access is also provided for Extended FGA terminating calls established on a 1+ basis (i.e., toll) outside the specific FGA Access Area (i.e., local calling area), however, inside the LATA. When a FGA customer chooses to terminate toll calls outside the FGA Access Area via an Interexchange Carrier's Service (i.e., no screening or blocking performed by customer), the rates and charges in 4.5.2(N)(3)(b) apply. The Telephone Company may, at the customer's request, and depending on the technical capabilities, screen and block such interLATA calls. Access is also provided to local operator service (0- and 0+), directory assistance (411 and 555-1212), emergency reporting service (911), local telephone repair (611), information services (e.g., time and temperature) and IC services (by dialing the appropriate digits). The customer will be billed for an operator surcharge as specified in the Local Tariffs, for local operator assistance (0-) calls; certain community information service calls; directory assistance (411 and 555-1212) calls; and customer call charges in accordance with other IC tariffs in force when the Telephone Company performs the billing for such customer calls.

Issued: July 29, 2020
Issued by Ziplay Fiber
By Jessica Epley, Regulatory & External Affairs Director

Effective: July 31, 2020

FACILITIES FOR INTRASTATE ACCESS

4. SWITCHED ACCESS (Cont'd)4.2 Description of Switched Access (Cont'd)4.2.1 Description of Feature Groups (Cont'd)(A) Feature Group A (Cont'd)

(6) (Cont'd)

Access to these services may, at the option of the customer, be blocked when the Call Denial on Line or Hunt Group three digit or six digit dial code screening arrangements are provided, subject to the availability of the equipment in the end office from which FGA is provided. Call Denial on Line or Hunt Group is an arrangement which will screen terminating calls except calls to 411, 611, 911, 800, 877, 888, 555-1212, and a set of NXXs specified by the Telephone Company for each end office switch and route all other calls to reorder tone or recorded announcement.

Three digit dial code screening is an arrangement which will screen terminating calls and allow completion of calls to one or more specific NXXs (or all NXXs) within the Home NPA, or calls to one, two, or three digit service codes (e.g., 0, 411) and route all others to reorder tone or recorded announcement.

Six digit dial code screening is an arrangement which will screen Access Area terminating calls and allow completion of calls to selected NXXs within foreign NPAs and route all other calls in the foreign NPA to reorder tone or recorded announcement.

(7) FGA is provided on a single line basis. FGA may, at the option of the customer, be provided in a Hunt Group Arrangement or a Uniform Call Distribution Arrangement. When FGA is provided with these arrangements, the FGA may also, at the option of the customer, be provided with a Nonhunting Number Arrangement. The Uniform Call Distribution Arrangement and the Nonhunting Number Arrangement are only available from certain Telephone Company end office switches. All FGA in a Hunt Group Arrangement or Uniform Call Distribution Arrangement with the Nonhunting Number Arrangement will be similarly arranged.

(8) A seven digit telephone number assigned by the Telephone Company is provided for access to FGA in the originating direction. The seven digit local telephone number will be associated with the selected end office switch and is of the form NXX-XXXX. If the customer requests a specific seven digit telephone number that is not currently assigned and the Telephone Company can, with reasonable effort, comply with that request, the requested number will be assigned to the customer.

WN U-16
Zipty Fiber

Original Sheet 129

FACILITIES FOR INTRASTATE ACCESS

4. SWITCHED ACCESS (Cont'd)

4.2 Description of Switched Access (Cont'd)

4.2.1 Description of Feature Groups (Cont'd)

(A) Feature Group A (Cont'd)

(9) FGA is provided with basic testing at no additional charge. Basic tests include: loss, 3 tone slope, (C-message and C-notched), dc continuity, and when applicable, operational signaling.

- Where Telephone Company equipment is available a seven digit access number will be provided to the customer for testing in the terminating direction. These access numbers shall include: balance (100 type) test line, and milliwatt (102 type) test line.

Additional testing will apply as described in 6.6 when: (a) the customer requests a test not specified in the preceding; (b) the test requested is not essential to the ongoing maintenance of FGA; or (c) the customer requests testing on a more frequent basis than scheduled for in the Telephone Company's Central Office Maintenance Planning System (COMPS). The Telephone Company will routinely perform maintenance testing from the dial tone end office to the customer's first point of switching.

(10) When all FGA for an individual customer (a single line or entire hunt group) is discontinued at an end office, a regular number intercept announcement is provided. This arrangement provides, for a limited period of time, an announcement that the service associated with the number dialed has been disconnected.

(11) FGA is provided with either Type B or Type C transmission performance. The parameters associated with these performances are guaranteed to the first point of switching. Type C transmission performance is provided with Interface Arrangement 1 and Type B is provided with Interface Arrangements 2 through 10. In addition, Data Transmission Parameters may, at the option of the customer, be provided with FGA.

FACILITIES FOR INTRASTATE ACCESS

4. SWITCHED ACCESS (Cont'd)4.2 Description of Switched Access (Cont'd)4.2.1 Description of Feature Groups (Cont'd)(B) Feature Group B

Feature Group B (FGB), which is available to all customers, provides trunk-side access to Telephone Company end office switches with an associated uniform 950-XXXX access code for originating and terminating communications. Feature Group B is available for customer provided intrastate communications capability or connection to an interexchange intrastate service.

- (1) FGB, when provided without the use of an access tandem switch (in a directly routed arrangement), is provided at all Telephone Company appropriately equipped electronic end office switches. When provided via Telephone Company appropriately equipped electronic access tandem switches, FGB End Office Services are provided at all Telephone Company subtending end office switches in the terminating direction and at appropriately equipped end offices in the originating direction utilizing the end user access code of 950-XXXX. For those subtending end offices that are not appropriately equipped, access in the originating direction is available by the end user access code of 1+950-XXXX.

FGB utilizes a two-point electrical communications path between the Interface Arrangement and the Common Line or a Special Access Line, as in 4.2.1(B), which is a voice grade transmission path comprised of any form or configuration of plant capable of, and typically used in the telecommunications industry for, the transmission of the human voice and associated telephone signals within the frequency bandwidth of approximately 300 to 3000 Hz.

- (2) FGB is provided as trunk side switching through the use of end office switch trunk equipment. The switch trunk equipment is provided with wink start pulsing and answer and disconnect supervisory signaling.
 - (3) The Telephone Company will select the trunking arrangement from the end office, within the selected Access Area from which FGB is to be provided. If the customer orders an Automatic Number Identification (ANI) Arrangement or Rotary Dial Station Signaling, where available, special routing and trunking arrangements may be required.
-

WN U-16
ZiPLY Fiber

Original Sheet 131

FACILITIES FOR INTRASTATE ACCESS

4. SWITCHED ACCESS (Cont'd)

4.2 Description of Switched Access (Cont'd)

4.2.1 Description of Feature Groups (Cont'd)

(B) Feature Group B (Cont'd)

- (4) FGB is arranged for either originating, terminating, or two-way calling based on the trunks or BHMC ordered. The Telephone Company will determine the type of directional calling to be provided unless the customer requests the option, Customer Specification of Switched Access Directionality as described in 4.2.5(H). For such specification, additional charges on an Individual Case Basis will apply if the calling arrangements are different from that the Telephone Company would have provided without such special arrangements. Originating calling permits the origination of calls from the end user to the CDL. Terminating calling permits the termination of calls from the CDL to the end user. Two-way calling permits either the origination or termination of calls, but not simultaneously.
- (5) FGB, when being used in the terminating and originating direction, is provided with multifrequency address signaling. At the option of the customer, up to Seven Digits Outpulsing of Access Digits to the customer will be provided in the originating direction by the Telephone Company equipment to the CDL where the FGB terminates. Except for FGB provided with the ANI arrangement or Rotary Dial Station Signaling as described in 4.2.5(L), any other address signaling in the originating direction, if required by the customer, must be provided by the end user using inband tone signaling techniques. Such inband tone address signals will not be regenerated by the Telephone Company and will be subject to the ordinary transmission capabilities of the Switched Transport provided.
- (6) FGB, when being used in the terminating direction, may be used to access valid NXXs in the FGB Access Area. If the FGB connection is made directly to an end office the Access Area is that of that end office only. If the FGB connection is made to an access tandem the Access Area is that of all end offices subtending that access tandem. The description of any FGB Access Area will be provided to the customer upon request. Access is also available to information services (e.g., time and temperature) and IC services by dialing the appropriate digits and other services when those services can be reached using valid NXX codes. Premium End Office Switching - Bundled (EOSB) rates in 4.5.2(H)(5) and 4.6.3(A) apply to all FGB usage originating or terminating at an equal access end office. When a provider of MTS and WATS subscribes to FGB and FGC at an end office, FGC usage and FGB terminating usage will be subject to premium EOSB rates and FGB originating usage will be subject to nonpremium EOSB rates.

WN U-16
ZiPLY Fiber

Original Sheet 132

FACILITIES FOR INTRASTATE ACCESS

4. SWITCHED ACCESS (Cont'd)

4.2 Description of Switched Access (Cont'd)

4.2.1 Description of Feature Groups (Cont'd)

(B) Feature Group B (Cont'd)

- (7) A separate trunk group will be established based on the directionality (i.e., originating only, terminating only, or two-way traffic) of the FGB arrangement provided.
- (8) The access code for FGB is a uniform access code in the form of 950-XXXX. For end offices not appropriately equipped an IC may instruct their end users to access the FGB by dialing 1+950-XXXX.
- (9) FGB may, at the option of the customer, be arranged to provide an ANI arrangement to obtain the calling station billing numbers. ANI is not available if the FGB connection is at an access tandem. The ANI arrangement provides seven digit calling station billing number information to the CDL. In those situations where no billing number is available in the end office switch, as with four party service, no seven digit number will be provided and an "operator identification" information digit will be provided.

In those cases where an ANI failure has occurred in the end office switch, no seven digit number will be provided, and an "identification failure" information digit will be provided. ANI will be available using multifrequency signaling provided by the Telephone Company.

Rotary Dial Station Signaling will be made available in certain end offices using dial repeating equipment provided by the Telephone Company. The customer must order Switched Transport arranged to pass the dial repeating signals. FGB is provided in directly routed arrangements where the ANI or Rotary Dial Station Signaling arrangements are provided.

Only calls from end users terminated on the end office switch will be provided with the ANI or Rotary Dial Station Signaling arrangements.

- (10) The Telephone Company will determine the end office ANI protocol for FGB. The Telephone Company makes no guarantee that ANI will be available at all end offices which have access to FGB.

FACILITIES FOR INTRASTATE ACCESS

4. SWITCHED ACCESS (Cont'd)4.2 Description of Switched Access (Cont'd)4.2.1 Description of Feature Groups (Cont'd)(B) Feature Group B (Cont'd)

- (11) FGB is provided with basic testing at no additional charge. Basic tests include: loss, 3 tone slope, (C-message and C-notched), and where applicable, dc continuity, signaling and balance testing.
- (a) Where Telephone Company equipment is available, a seven digit access number will be provided to the customer for testing in the terminating direction. These access numbers shall include: balance (100 type) test line, milliwatt (102 type) test line, data transmission (107 type) test line, loop around test line, short circuit test line and open circuit test line.
- (b) Where Telephone Company equipment is available and the customer is equipped with compatible remote office test lines, FGB will be provided with automatic testing (105 type or equivalent) in the originating direction.

Additional testing charges apply as described in 6.6 when: (a) the customer requests a test not specified in the preceding; (b) the test requested is not essential to the ongoing maintenance of FGB; or (c) the customer requests testing on a more frequent basis than scheduled in the Telephone Company's Central Office Maintenance Planning System (COMPS). The Telephone Company will routinely perform maintenance testing from its access tandem or end office (if directly routed) to the customer's first point of switching.

- (12) When all FGB is discontinued at an end office and/or in an Access Area, a regular number intercept announcement is provided. This arrangement provides, for a limited period of time, an announcement that the FGB associated with the number dialed has been disconnected.
- (13) FGB is provided with either Type B or Type C transmission performance. The parameters associated with these performances are guaranteed to the end office, when routed directly, or to the first point of switching, when routed via an access tandem. Type C transmission performance is provided with Interface Arrangement 1 and Type B is provided with Interface Arrangements 2 through 10. In addition, Data Transmission Parameters may, at the option of the customer, be provided with FGB.
- (14) FGB may at the option of the customer and with the concurrence of the Telephone Company, be provided with Alternate Traffic Routing. This arrangement, as shown in 4.2.5(A), delivers originating traffic from an end office over a designated trunk group to the CDL. When that trunk group is fully loaded, additional originating traffic is automatically delivered over one or more designated trunk groups to one or more CDLs.
-

FACILITIES FOR INTRASTATE ACCESS

4. SWITCHED ACCESS (Cont'd)4.2 Description of Switched Access (Cont'd)4.2.1 Description of Feature Groups (Cont'd)(C) Feature Group C

Feature Group C (FGC) provides trunk side access to Telephone Company end office switches for providers of MTS and WATS for originating and terminating communications. FGC is available in all end offices which are not equipped for FGD End Office Services. A more detailed description of FGC is in 4.2.4(D).

- (1) FGC is provided at all Telephone Company end office switches or Telephone Company designated access tandem switches. FGC is available at an end office switch unless FGD is provided in the same office. When FGD or BSA-D is available, FGC or BSA-D will be discontinued as soon as the conversion to FGD can be arranged.

FGC utilizes a two-point electrical communications path between the Interface Arrangement and the Common Line or a Special Access Line which is a voice grade transmission path comprised of any form or configuration of plant capable of, and typically used in the telecommunications industry for, the transmission of the human voice and associated signals within the frequency bandwidth of approximately 300 to 3000 Hz.

- (2) FGC is provided as trunk side switching through the use of end office switch trunk equipment. The switch trunk equipment is provided with answer and disconnect supervisory signaling. Wink start pulsing signals are provided in all offices where available. In those offices where wink start pulsing signals are not available, delay dial start pulsing signals will be provided.
 - (3) The Telephone Company will select the trunking arrangement from the end office, within the selected Access Area from which FGC is to be provided. If the customer orders an ANI Arrangement or Service Class Routing Arrangement, special routing and trunking arrangements may be required.
 - (4) FGC is arranged for either originating calling only, terminating calling only, or two-way calling based on the trunks or BHMC ordered. The Telephone Company will determine the type of directional calling to be provided unless the customer requests the option, Customer Specification of Directionality as described in 4.2.5(H). For such specification, additional charges on an Individual Case Basis will apply if the trunk group routing arrangements are different from that the Telephone Company would have provided without such special arrangements. Originating calling permits the origination of calls from the end user to the CDL. Terminating calling permits the termination of calls from the CDL to the end user. Two-way calling permits either the origination or termination of calls, but not simultaneously.
-

WN U-16
ZiPLY Fiber

Original Sheet 135

FACILITIES FOR INTRASTATE ACCESS

4. SWITCHED ACCESS (Cont'd)

4.2 Description of Switched Access (Cont'd)

4.2.1 Description of Feature Groups (Cont'd)

(C) Feature Group C (Cont'd)

- (5) FGC is provided with multifrequency address signaling except in certain electromechanical end office switches where multifrequency signaling is not available. In such electromechanical end office switches, the address signaling will be dial pulse or revertive pulse signaling, whichever is available. Dial pulse address signaling may, at the option of the customer, be provided in lieu of multifrequency address signaling if such signaling facilities are available in the end office. Up to twelve digits of the called party number dialed by the customer's end user will be provided by Telephone Company equipment to the CDL where the FGC terminates. Such called party number signals will be subject to the ordinary transmission capabilities of the switched Transport provided.
- (6) FGC, when being used in the terminating direction, may be used to access NXXs in the FGC Access Area. If the FGC connection is made directly to an end office, the Access Area is that of that end office only. If the FGC connection is made to an access tandem, the Access Area is that of all end offices subtending that access tandem. The description of any FGC Access Area will be provided to the customer upon request. Access is also available to Directory Assistance and other services (by dialing the appropriate codes) when the services can be reached using valid NXX codes.
- (7) A separate trunk group will be established based on the directionality (i.e., originating only, terminating only, or two-way traffic) of the FGC arrangement provided.
- (8) No access code is required for FGC. In certain locations, due to Central Office equipment limitations, two or three digit access codes may be used. The number dialed by the end user shall be a seven or ten digit number for calls in the North American Numbering Plan (NANP). The form of the numbers dialed by the end user is NXX-XXXX, 0 or 1+ NXX-XXXX, NPA + NXX-XXXX, 0 or 1 + NPA + NXX-XXXX.

The use of the access codes 1+, 0+ and 0 for the initiation of intraLATA calls, both MTS and WATS, is reserved to the Telephone Company for use as determined by the Telephone Company.

WN U-16
ZiPLY Fiber

Original Sheet 136

FACILITIES FOR INTRASTATE ACCESS

4. SWITCHED ACCESS (Cont'd)

4.2 Description of Switched Access (Cont'd)

4.2.1 Description of Feature Groups (Cont'd)

(C) Feature Group C (Cont'd)

- (9) FGC may, at the option of the customer, be arranged to provide an ANI Arrangement to obtain the calling station billing number. The ANI Arrangement provides seven digit station billing number information to the CDL. In those situations where no billing number is available in the end office switch, as with four party service, no seven digit number will be provided and an "operator identification" information digit will be provided.

In those cases where an ANI failure has occurred in the end office switch, no seven digit number will be provided and an "identification failure" information digit will be provided. ANI will be made available using multifrequency signaling provided by the Telephone Company.

FGC is provided in directly routed arrangements to the end office switch where the ANI Arrangement is provided. The Telephone Company will determine the end office ANI protocol for FGC.

Only calls from end users terminated on the end office switch will be provided with the ANI Arrangement. ANI is provided from end offices for which Telephone Company recording for end user billing is not provided, or where it is not required, as with 800/877/888 Service. It is not provided from end offices for which the Telephone Company needs to forward ANI to its recording equipment.

- (10) FGC is provided with basic testing at no additional charge. Basic tests include: loss, 3 tone slope, (C-message and C-notched), and where applicable, signaling and balance testing.
- (a) Where Telephone Company equipment is available, a seven digit access number will be provided to the customer for testing in the terminating direction. The access number shall include: balance (100 type) test line, milliwatt (102 type) test line, automatic transmission measuring (105 type) test line, data transmission (107 type) test line, nonsynchronous or synchronous test line, loop around test line, short circuit test line and open circuit test line.
- (b) Where Telephone Company equipment is available and the customer is equipped with compatible equipment (remote office test lines and 105 test lines with associated responders or their functional equivalent), FGC will be provided with automatic testing.
-

WN U-16
Zipty Fiber

Original Sheet 137

FACILITIES FOR INTRASTATE ACCESS

4. SWITCHED ACCESS (Cont'd)

4.2 Description of Switched Access (Cont'd)

4.2.1 Description of Feature Groups (Cont'd)

(C) Feature Group C (Cont'd)

(10) (Cont'd)

- (c) At the option of the Telephone Company, cooperative testing may be provided in lieu of automatic testing. Cooperative testing is where the Telephone Company provides a technician at its office(s) and the customer provides a technician at its CDL, with suitable test equipment to perform the required tests. The Telephone Company will routinely perform maintenance testing from its access tandem or end office (if direct routed) to the customer's first point of switching.

Additional testing charges will apply as specified in 6.6 when: (a) the customer requests a test not specified in the preceding; (b) the test requested is not essential to the ongoing maintenance of FGC; or (c) the customer requests testing on a more frequent basis than scheduled in the Telephone Company's Central Office Maintenance Planning System (COMPS).

- (11) FGC may, at the option of the customer, be provided with Alternate Traffic Routing. This arrangement delivers originating traffic from an end office over a designated trunk group to the CDL. When that trunk group is fully loaded, additional originating traffic is automatically delivered over a second designated trunk group to a second CDL. For existing arrangements only, up to three trunk groups to three CDLs may be provided.
- (12) FGC may, at the option of the customer, be provided with a Service Class Routing Arrangement. This arrangement allows originating traffic to be delivered over selected trunk groups to specified CDLs based on service prefix (e.g., 0-, 0+, 1+, 01, 011); service class codes (e.g., 500, 700, 800, 877, 888, 900); or end user originating line class of service (e.g., coin, multiparty, hotel/motel).
- (13) FGC may, at the option of the customer, be provided with a Trunk Access Limitation Arrangement in all Telephone Company end offices. This arrangement provides for the routing of designated (e.g., 900 Service Code) originating calls to a specified number of transmission paths in a trunk group to the CDL in order to limit the amount of such traffic that can be completed.
- (14) FGC is provided with the following features in the originating direction for operator assistance services. FGC may require the routing by Service Class Routing Arrangement as described in 4.2.1(C)(15).
-

WN U-16
ZiPLY Fiber

Original Sheet 138

FACILITIES FOR INTRASTATE ACCESS

4. SWITCHED ACCESS (Cont'd)

4.2 Description of Switched Access (Cont'd)

4.2.1 Description of Feature Groups (Cont'd)

(C) Feature Group C (Cont'd)

(14) (Cont'd)

(a) Operator Assistance-Coin Control Arrangements for Telephone Company End Offices Where Equipment Is Available - Such arrangements provide coin return control and routing of 0+, 0-, 01+ and 011+ prefixed originating calls to the CDL. The operator services system arrangement for receipt of 0+, 0-, 1+, 01+ and 011+ calls may, at the option of the customer, be provided with the ANI Arrangement. The cord board arrangement for receipt of 0- originating calls is not provided with ANI. FGC is provided in a directly routed arrangement where the Operator Assistance-Coin Control Arrangement is provided. Only calls from coin station lines terminated on the end office switch where the Operator Assistance-Coin Control Arrangement is provided will be provided to the CDL.

(b) Operator Assistance-Noncoin Arrangements In All Telephone Company End Offices - Such arrangements provide routing of 0+, 0-, 1+, 01+, and 011+ prefixed originating calls to the CDL. This arrangement for receipt of 0+, 0-, 1+, 01+, and 011+ originating calls may, at the option of the customer, be provided with the ANI Arrangement.

The cord board arrangement for receipt of 0- originating calls is not provided with ANI. FGC is provided in a directly routed arrangement where the Operator Assistance-Noncoin Arrangement is provided. Only calls from end users terminated on the end office switch where the Operator Assistance-Noncoin Arrangement is provided will be provided to the CDL.

(c) Operator Assistance - Combined (Coin and Noncoin) Arrangements in Telephone Company End Offices Where Equipment Is Available - This arrangement provides the combined features described in (a) and (b).

(15) FGC is provided with either Type B or Type C transmission performance as follows: a) when routed directly to the end office, either Type B or Type C is provided; b) when routed to an access tandem, only Type B is provided; or c) Type B or Type C is provided on the transmission path from the access tandem to the end office. Type C transmission performance is provided with Interface Arrangement 1 when routed directly to an end office. Type B is provided with Interface Arrangement 2 through 10 whether routed directly to an end office or to an access tandem. In addition, Data Transmission Parameters may, at the option of the customer, be provided with FGC.

WN U-16
ZiPLY Fiber

Original Sheet 139

FACILITIES FOR INTRASTATE ACCESS

4. SWITCHED ACCESS (Cont'd)

4.2 Description of Switched Access (Cont'd)

4.2.1 Description of Feature Groups (Cont'd)

(D) Feature Group D

Feature Group D (FGD), which is available to all customers, provides trunk side access to Telephone Company end office switches with an associated 101XXXX access code for providers of MTS/WATS and MTS/WATS-type services for originating and terminating communications for customer provided intrastate communications capability or connection to an interexchange intrastate service.

- (1) FGD is provided at Telephone Company appropriately equipped electronic end office switches.

FGD utilizes a two-point electrical communication path between the Interface Arrangement and the Common Line or Special Access Line which is a voice grade transmission path comprised of any form or configuration of plant capable of, and typically used in the telecommunications industry for, the transmission of the human voice and associated telephone signals within the frequency bandwidth of approximately 300 to 3000 Hz.

SS7 out of Band Signaling for FGD is provided at suitable equipped Telephone Company end office or access tandem switches.

- (2) FGD is provided as trunk side switching through the use of end office or access tandem switch trunk equipment. The switch trunk equipment is provided with answer and disconnect supervisory signaling and wink start pulsing signals except when SS7 Out of Band Signaling is specified.
- (3) The Telephone Company will select the trunking arrangement from the end office, within the selected Access Area from which FGD is to be provided. If the customer orders an Automatic Number Identification (ANI) Arrangement, Alternate Traffic Routing Arrangement, Service Class Routing Arrangement, Trunk Access Limitation Arrangement, or Operator Assistance Full Feature Arrangement, special routing and trunking arrangements may be required.

FACILITIES FOR INTRASTATE ACCESS

4. SWITCHED ACCESS (Cont'd)4.2 Description of Switched Access (Cont'd)4.2.1 Description of Feature Groups (Cont'd)(D) Feature Group D (Cont'd)

- (4) FGD is arranged for either originating calling only, terminating calling only, or two-way calling and based on the trunks or BHMC ordered. The Telephone Company will determine the type of directional calling to be provided unless the customer orders an Operator Assistance Full Feature Arrangement or requests the option, Customer Specification of Switched Access Directionality. For such arrangements, additional charges on an Individual Case Basis will apply if the trunking arrangements are different from that the Telephone Company would have provided without such special arrangements. Originating calling permits the origination of calls from the end user to the CDL. Terminating calling permits the termination of calls from the CDL. Two-way calling permits either the origination or termination of calls, but not simultaneously.
 - (5) FGD is provided with multifrequency address signaling or SS7 Out of Band Signaling. Up to twelve digits of the called party number dialed by the end user will be provided by Telephone Company equipment to the CDL where the FGD terminates. Such address signals will be subject to the ordinary transmission capabilities of the Switched Transport provided.
 - (6) FGD, when being used in the terminating direction, may be used to access valid NXXs in the FGD Access Area. If the FGD connection is made directly to an end office the Access Area is that of that end office only. If the FGD connection is made to a Telephone Company access tandem, the Access Area is all end offices subtending that access tandem that have FGD capabilities. When the customer wants access to all end offices subtending that access tandem (both equal access and non-equal access) a single FGD trunk group may be used. Traffic terminating at a non-equal access end office using a FGD trunk group will be ordered as FGB or FGC and billed at FGB or FCC rates. Separate trunk groups for the combined use of FGD and FGB or FGD and FGC are not required. The description of any FGD Access Area will be provided to the customer upon request. FGD may also be used in the terminating direction to access information services (e.g., time and temperature) and other services by dialing the appropriate codes when the services can be reached using valid NXX codes.
 - (7) A separate trunk group will be established based on directionality (i.e., originating only, terminating only, or two-way traffic) of the FGD arrangement provided.
-

WN U-16
ZiPLY Fiber

Original Sheet 141

FACILITIES FOR INTRASTATE ACCESS

4. SWITCHED ACCESS (Cont'd)

4.2 Description of Switched Access (Cont'd)

4.2.1 Description of Feature Groups (Cont'd)

(D) Feature Group D (Cont'd)

- (8) The access code for FGD is a uniform access code in the form 10XXX or 101XXXX. No access code is required if the end user's Telephone Company local service is arranged for the Primary Interexchange Carrier (PIC) arrangement as in 6.5 to the same IC.

The number dialed by the end user shall be a seven or ten digit number for calls in the North American Numbering Plan (NANP). The form of the telephone number dialed by an end user is NXX-XXXX or 0 or 1+NXX-XXXX, NPA-NXX-XXXX or 1+NPA-NXX-XXXX. When the 101XXXX access code is used, FGD also provides for dialing the digit 0 for access to the customer's operator, or the end-of-dialing digit (#) for cut-through access to the CDL. FGD also provides for the dialing of digits 00 for access on a non-DDD basis to the customer's operator when the end user's service is designated to the customer as in 6.5 and 4.2.5(V). A single access code will be the assigned number for all FGD service provided to the customer by the Telephone Company.

In addition to the standard 101XXXX access code, the customer has the option to use 950-XXXX as an access code for FGD Switched Access Service. When the customer orders FGD Switched Access Service with 950-XXXX Access as described in 4.2.5(S). FGD switched access calls may also be originated by using the customer's 950-XXXX access code(s). All such calls will be rated as FGD switched access calls.

FGD, provided with multifrequency address signaling or SS7 Out of Band Signaling, is arranged to receive address signaling through the use of Dual Tone Multifrequency (DTMF) or dial pulse address signaling from the end user.

WN U-16
ZiPLY Fiber

Original Sheet 142

FACILITIES FOR INTRASTATE ACCESS

4. SWITCHED ACCESS (Cont'd)

4.2 Description of Switched Access (Cont'd)

4.2.1 Description of Feature Groups (Cont'd)

(D) Feature Group D (Cont'd)

- (9) FGD may, at the option of the customer, be arranged to provide ANI Arrangement to obtain the calling station billing number. The ANI Arrangement provides ten digit station billing number information to the CDL. When SS7 Out of Band Signaling is specified, the customer may obtain an ANI equivalent by ordering the Charge Number optional feature described in 4.2.5(Z). In those situations where no billing number is available in the end office switch, as with four party service, no ten digit number will be provided, only the area code and an "operator identification" information digit will be provided.

In those cases where an ANI failure has occurred in the end office switch, no ten digit number will be provided, and an "identification failure" information digit will be provided. ANI will be made available using multifrequency signaling provided by the Telephone Company.

Dependent upon the group type, the ANI spill may be forwarded prior to the called number in appropriately equipped end offices. When the ANI spill is sent prior to the called number, ten digits will be forwarded (NPA + NXX-XXXX). When the ANI spill is sent after the called number, the conventional seven digits will be forwarded. The Telephone Company will determine the sequencing and protocol of the ANI spill and called number.

- (10) FGD is provided with basic testing at no additional charge. Basic tests include: loss, 3 tone slope, (C-message and C-notched), and where applicable, signaling and balance testing.
- (a) Where Telephone Company equipment is available, a seven digit access number will be provided to the customer for testing in the terminating direction. These access numbers shall include: balance (100 type) test line, milliwatt (102 type) test line, nonsynchronous or synchronous test line, automatic transmission measuring (105 type) test line, data transmission (107 type) test line, loop around test line, short circuit test line and open circuit test line. Access to test lines by other than seven digits is at the option of the Telephone Company and may vary in availability.
- (b) Where Telephone Company equipment is available and the customer is equipped with compatible equipment (remote office test lines and 105 test lines with associated responders or their functional equivalent), FGD will be provided with automatic testing.

WN U-16
ZiPLY Fiber

Original Sheet 143

FACILITIES FOR INTRASTATE ACCESS

4. SWITCHED ACCESS (Cont'd)

4.2 Description of Switched Access (Cont'd)

4.2.1 Description of Feature Groups (Cont'd)

(D) Feature Group D (Cont'd)

(10) (Cont'd)

(c) At the option of the Telephone Company, cooperative testing may be provided in lieu of automatic testing. Cooperative testing is where the Telephone Company provides a technician at its office(s) and the customer provides a technician at its CDL, with suitable test equipment to perform the required tests. The Telephone Company will routinely perform maintenance testing from its access tandem or end office, (if direct routed) to the customer's first point of switching.

(d) When FGD or 800/877/888 Access service with SS7 Out of Band Signaling is ordered, network compatibility and other operational tests will be performed cooperatively by the Telephone Company and the customer at locations, dates, and times as specified by the Telephone Company in consultation with the customer. These tests are as specified in Bellcore TTechnical Reference Publication TR-TSV-000905. Successful completion is necessary to receive the SS7 signaling option. To protect the security of the SS7 network, certain information provided, i.e., point codes, by the Telephone Company to the customer will be subject to a nondisclosure agreement.

Additional testing charges will apply as specified in 6.6 when: (a) the customer requests a test not specified in the preceding; (b) the test requested is not essential to the ongoing maintenance of FGD; or (c) the customer requests testing on a more frequent basis than scheduled in the Telephone Company's Central Office Maintenance Planning System (COMPS).

(11) FGD may, at the option of the customer and with the concurrence of the Telephone Company, be provided with Alternate Traffic Routing. This arrangement delivers originating traffic from an end office over a designated trunk group to the CDL. When that trunk group is fully loaded, additional originating traffic is automatically delivered over a second designated trunk group to a second CDL. For existing arrangements only, up to three trunk groups to three CDLs may be provided.

FACILITIES FOR INTRASTATE ACCESS

4. SWITCHED ACCESS (Cont'd)4.2 Description of Switched Access (Cont'd)4.2.1 Description of Feature Groups (Cont'd)(D) Feature Group D (Cont'd)

- (12) FGD may, at the option of the customer, be provided with a Service Class Routing Arrangement. This arrangement allows originating traffic to be delivered over selected trunk groups to specified CDLs based on service prefix code (e.g., 0-, 0+, 1+, 01, 011); service class codes (e.g., 500, 700, 800, 877, 888, 900); or end user originating line class of service (e.g., coin, multiparty, hotel/motel). Service classes of traffic unable to be served by a customer will be handled at the option of the Telephone Company.
 - (13) FGD will be arranged to accept calls from Telephone Company local service without the 101XXXX uniform access code. Each Telephone Company's local service will be marked to identify which 101XXXX code its calls will be directed to for InterLATA Area service.
 - (14) FGD may, at the option of the customer, be provided with a Trunk Access Limitation Arrangement. The Trunk Access Limitation Arrangement provides for the routing of designated (e.g., 900 Service class code) originating calls to a specified number of transmission paths in a trunk group.
 - (15) FGD may, at the option of the customer and with the concurrence of the Telephone Company, be provided with an Operator Assistance Full Feature Arrangement. This arrangement provides, to the customer operator, the initial coin control function. FGD is provided in a directly routed arrangement from the end office switch when this feature is provided. This feature may require the routing by Service Class Routing Arrangement, as in 4.2.5(M). The coin collection and return protocol required by the customer must be compatible with Telephone Company equipment. Offering of this feature is contingent upon suitable administrative procedures/agreements for coin services being negotiated between the customer and the Telephone Company. This option is unavailable with SS7 Out of Band Signaling.
 - (16) FGD is provided with either Type A, Type B, or Type C transmission performance as follows: a) when routed directly to the end office, either Type B or Type C is provided; b) when routed to an access tandem, only Type A is provided; c) Type A is provided on the transmission path from the access tandem to the end office. Type C transmission performance is provided with Interface Arrangement 1. Type A and Type B are provided with Interface Arrangements 2 through 10. In addition, Data Transmission Parameters may, at the option of the customer, be provided with FGD.
 - (17) FGD trunking arrangements are available with two basic forms of signaling protocol. The standard signaling protocol provided with FGD is Overlap Outpulsing. At the option of the customer, where technically available, FGD may be provided with Non-Overlap Outpulsing signaling protocol.
-

FACILITIES FOR INTRASTATE ACCESS

4. SWITCHED ACCESS (Cont'd)4.2 Description of Switched Access (Cont'd)4.2.1 Types of Feature Groups (Cont'd)(E) SAC Access Service

Service Access Code (SAC) Access Service is an originating service that is provided via SAC Access Service switched trunk groups, or may be provided with FGC or FGD. SAC Access Service may also be provided with BSA-C or BSA-D or BSA-D as shown in 4.2.2. When a 1+500-NXX-XXXX, or 0+500-NXX-XXXX call is originated by an end user for 500 SAC Access Service, the 500 Customer Identification Function, as described in 4.2.19, determines the customer to which the call is to be routed based on the 500 NXX code dialed. When a 1+800-NXX-XXXX, 1+877-NXX-XXXX, or 1+888-NXX-XXXX call is originated by an end user for 800/877/888 SAC Access Service, the 800/877/888 Customer Identification Function as described in 4.2.10, determines the customer to which the call 800, 877, or 888 call is routed. When a 1+900-NXX-XXXX call is originated by an end user for 900 SAC Access Service, the 900 Customer Identification Function, as described in 4.2.11, determines the customer to which the call is to be routed based on the 900 NXX code dialed.

- (1) Service Access Code (SAC) Access Service is provided at Telephone Company appropriately equipped end office or tandem switches.
- (2) Originating SAC Access Service is a trunk side switched service that is available to the customer via SAC Access Service trunk groups. The appropriate Customer Identification Function, as described in 4.2.10, 4.2.11 and 4.2.19 must be ordered with each SAC Access Service trunk group. SAC Access Service traffic at the option of the customer can be carried on the same group with non-SAC Access traffic.
- (3) When a 1+N00-NXX-XXXX call is originated by an End User, the Telephone Company will perform the Customer Identification Function based upon the dialed digits to determine the disposition of the call. If the call originates from an end office not equipped to provide the Customer Identification Function, the call will be routed to an office where the function is available. Once the Customer Identification Function has been performed, the call will be routed to the customer.

WN U-16
ZiPLY Fiber

Original Sheet 146

FACILITIES FOR INTRASTATE ACCESS

4. SWITCHED ACCESS (Cont'd)

4.2 Description of Switched Access (Cont'd)

4.2.1 Types of Feature Groups (Cont'd)

(E) SAC Access Service (Cont'd)

- (4) The manner in which SAC Access Service is provided is dependent on the status of the end office from which the service is provided (i.e., equipped with equal access capabilities or not equipped with equal access capabilities). When SAC Access Service is provided from an end office equipped with equal access capabilities, all such service will be provisioned in accordance with the technical characteristics available with FGD or BSA-D except when more than one tandem is employed in the transport of a SAC Access Service call.

When SAC Access Service is provided from an end office not equipped with equal access capabilities, such service will be provisioned in accordance with the technical characteristics available with FGC, FGD, BSA-C, BSA-D. In either case, when more than one tandem is employed in the transport of a SAC Access Service call, Standard Transmission characteristics are not guaranteed.

- (5) For other than FGC or BSA-C, end offices that lack equal access or the Customer Identification Function capabilities, may only be served via a Telephone Company access tandem over FGD or BSA-D trunks or SAC Access Service trunk groups. For FGC or BSA-C, SAC Access Service can be provided through an existing trunk group or separate FCC or BSA-C trunk group which handles SAC Access Service. SAC Access Service from an access tandem, with both equal and nonequal access end offices, can be combined on a single FGD or BSA-D trunk group to the CDL. SAC Access Service from an access tandem with nonequal access end offices can be provided on a FGC or BSA-D trunk group.

WN U-16
ZiPLY Fiber

Original Sheet 147

FACILITIES FOR INTRASTATE ACCESS

4. SWITCHED ACCESS (Cont'd)

4.2 Description of Switched Access (Cont'd)

4.2.1 Types of Feature Groups (Cont'd)

(E) SAC Access Service (Cont'd)

- (6) 500 SAC Access Service originating from equal access end offices with the 500 Customer Identification Function may be provided using exchange access signaling with overlap outpulsing and ten digit ANI. The 500 Customer Identification Function is described in 4.2.19. 900 SAC Access Service originating from equal access end offices with the 900 Customer Identification Function as described in 4.2.11, may be provided using the exchange access signaling with overlap outpulsing and ten digit ANI. 800/877/888 SAC Access Service originating from equal access end offices with the 800/877/888 Customer Identification Function described in 4.2.10 may be provided using exchange access signaling without overlap outpulsing and with ten digit ANI. SAC Access Service originating from equal access end offices without the customer identification capabilities, or from end offices not having equal access capability, may be provided using conventional signaling. On traffic using conventional signaling, other than FGC or BSA-C, the customer's facilities shall provide off hook supervision upon receipt of the transmitted digits.

SAC Access Service may also be provided with SS7 Out of Band Signaling from suitably equipped end office or access tandem switches.

- (7) For SAC Access Service traffic, other than 800/877/888 SAC Access, originating from equal access end offices with the Customer Identification Function, FGD parameters as specified in 4.2.1(C) apply or BSA-D parameters as specified in 4.2.2(D) apply.

For SAC Access Service traffic originating from all other end offices, FGC parameters as specified in 4.2.1(C) apply or BSA-C parameters as specified in 4.2.2(C) apply.

Telephone Company switch and customer premise interface as described in 4.2.3 for FGD also apply to SAC Access Service.

WN U-16
ZiPLY Fiber

Original Sheet 148

FACILITIES FOR INTRASTATE ACCESS

4. SWITCHED ACCESS (Cont'd)

4.2 Description of Switched Access (Cont'd)

4.2.2 Description of Basic Serving Arrangements (BSAs)

The Telephone Company, under the ordering provisions in Section 3, at rates and charges specified in 4.6, will provide Lineside and Trunkside Switched Access Basic Serving Arrangements (BSAs) as follows:

(A) BSA-A

Basic Serving Arrangement A (BSA-A), which is available to all customers, provides line-side access to Telephone Company end office switches with an end user access code of NXX-XXXX for the customer's use in originating and terminating communications. BSA-A is available as Message Telecommunications Service-type or Wide Area Telecommunications Service-type (MTS/WATS-type) access or as Foreign Central Office/Off Network Access Line (FCO/ONAL) open end access, for customer provided interstate communications capability or connection to an interexchange interstate service.

- (1) BSA-A is provided at all Telephone Company end office switches and switches customer communications to and from Common Lines, or Special Access Lines.

BSA-A utilizes a two-point electrical communications path between the Interface Arrangement and the Common Line or Special Access Line which is a voice grade transmission path comprised of any form or configuration of plant capable of, and typically used in the telecommunications industry for, the transmission of the human voice and associated telephone signals within the frequency bandwidth of approximately 300 to 3000 Hz.

WN U-16
ZiPLY Fiber

Original Sheet 149

FACILITIES FOR INTRASTATE ACCESS

4. SWITCHED ACCESS (Cont'd)

4.2 Description of Switched Access (Cont'd)

4.2.2 Description of Basic Serving Arrangements (BSAs) (Cont'd)

(A) BSA-A (Cont'd)

- (2) BSA-A is provided as line-side switching through end office switch line equipment. Line-side switching may, at the option of the customer, be provided with ground start supervisory signaling or loop start supervisory signaling. BSA-A may also be provided with certain Basic Service Elements (BSEs) as shown in 4.2.21.
- (3) The customer shall select the first point of switching, within the selected BSA-A Access Area.
- (4) BSA-A is arranged for originating calling only, terminating calling only or two-way calling. The Telephone Company will determine the type of calling to be provided unless the customer requests the option, Customer Specification of Switched Access Directionality as described in 4.2.5(H). For such specification, additional charges on an Individual Case Basis will apply if the calling arrangements are different than that the Telephone Company would have provided without such special arrangements. Originating calling permits the origination of calls from the end user to the CDL. Terminating calling permits the termination of calls from the CDL to the end user. Two-way calling permits either the origination or termination of calls, but not simultaneously.
- (5) BSA-A, when being used in the terminating direction, is arranged with dial tone start-dial signaling and dial pulse address signaling. BSA-A, when being used in the terminating direction, may, at the option of the customer, be arranged for Dual Tone Multifrequency (DTMF) address signaling, subject to availability of equipment in the end office from which BSA-A is provided. When BSA-A is provided in a Hunt Group Arrangement or Uniform Call Distribution Arrangement, as discussed in 4.2.21, all BSA-A will be arranged for the same type of signaling.

No address signaling is provided by the Telephone Company when BSA-A is used in the originating direction. Address signaling in such cases, if required by the customer, must be provided by the end user using inband tone signaling techniques. Such inband tone address signals will be subject to the ordinary transmission capabilities of the Switched Transport provided.

WN U-16
Zipty Fiber

Original Sheet 150

FACILITIES FOR INTRASTATE ACCESS

4. SWITCHED ACCESS (Cont'd)

4.2 Description of Switched Access (Cont'd)

4.2.2 Description of Basic Serving Arrangements (BSAs) (Cont'd)

(A) BSA-A (Cont'd)

- (6) BSA-A, when used in the terminating direction, may be used to access valid NXXs in the BSA-A Access Area. For BSA-A, the Access Area is defined as the local calling area of the end office switch from which the BSA-A is provided. The description of any specific BSA-A Access Area will be provided to the customer upon request. Access is also provided for Extended BSA-A terminating calls established on a 1+ basis (i.e., toll) outside the specific BSA-A Access Area (i.e., local calling area) however inside the LATA. When a BSA-A customer chooses to terminate toll calls outside the LATA via an Interexchange Carrier's Service (i.e., no screening or blocking performed by customer), the rates and charges in 4.5.2(H)(3) apply. The Telephone Company may, at the customer's request, and depending on the technical capabilities, screen and block such interLATA calls. Access is also provided to local operator service (0- and 0+), directory assistance (411 and 555-1212), emergency reporting service (911), local telephone repair (611), information services (e.g., time and temperature) and IC services (by dialing the appropriate digits). The customer will be billed for an operator surcharge as in the Telephone Company General and/or Local Tariffs, for local operator assistance (0-) calls; certain community information service calls; directory assistance (411 and 555-1212) calls; and customer call charges in accordance with other IC tariffs in force when the Telephone Company performs the billing for such customer calls.

Access to these services may, at the option of the customer, be blocked when the Call Denial on Line or Hunt Group three digit or six digit dial code screening arrangements are provided, subject to the availability of the equipment in the end office from which BSA-A is provided. Call Denial on Line or Hunt Group is an arrangement which will screen terminating calls except calls to 411, 611, 911, 800, 877, 888, 555-1212, and a set of NXXs selected by the customer, in cooperation with the Telephone Company for each end office switch and route all other calls to reorder tone or recorded announcement.

Three digit dial code screening is an arrangement which will screen terminating calls and allow completion of calls to one or more specific NXXs (or all NXXs) within the Home NPA or calls to one, two or three digit service codes (e.g., 0, 411) and route all others to reorder tone or recorded announcement.

Six digit dial code screening is an arrangement which will screen Access Area terminating calls and allow completion of calls to selected NXXs within foreign NPAs and route all other calls in the foreign NPA to reorder tone or recorded announcements.

WN U-16
Zipty Fiber

Original Sheet 151

FACILITIES FOR INTRASTATE ACCESS

4. SWITCHED ACCESS (Cont'd)

4.2 Description of Switched Access (Cont'd)

4.2.2 Description of Basic Serving Arrangements (BSAs) (Cont'd)

(A) BSA-A (Cont'd)

- (7) BSA-A is provided on a single line basis. When BSA-A is provided in a Hunt Group Arrangement or a Uniform Call Distribution Arrangement, the BSA-A may also, at the option of the customer, be provided with a Nonhunting Number Arrangement. The Uniform Call Distribution Arrangement and the Nonhunting Number Arrangement are only available from certain Telephone Company end office switches. All BSA-A in a Hunt Group Arrangement or Uniform Call Distribution Arrangement with the Nonhunting Number Arrangement will be similarly arranged.
- (8) A seven digit telephone number assigned by the Telephone Company is provided for access to BSA-A in the originating direction. The seven digit local telephone number will be associated with the selected end office switch and is of the form NXX-XXXX. If the customer requests a specific seven digit telephone number that is not currently assigned and the Telephone Company can, with reasonable effort, comply with that request, the requested number will be assigned to the customer.
- (9) BSA-A is provided with basic testing at no additional charge. Basic tests include: loss, 3 tone slope, (C-message and C-notched), dc continuity and when applicable operational signaling.

Where Telephone Company equipment is available, a seven digit access number will be provided to the customer for testing in the terminating direction. These access numbers shall include: balance (100 type) test line, and milliwatt (102 type) test line.

Additional testing will apply as in 6.6 when: (a) the customer requests a test not specified in the preceding; (b) the test requested is not essential to the ongoing maintenance of BSA-A; or (c) the customer requests testing on a more frequent basis than scheduled for in the Telephone Company's Central Office Maintenance Planning System (COMPS). The Telephone Company will routinely perform maintenance testing from the dial tone end office to the customer's first point of switching.

WN U-16
ZiPLY Fiber

Original Sheet 152

FACILITIES FOR INTRASTATE ACCESS

4. SWITCHED ACCESS (Cont'd)

4.2 Description of Switched Access (Cont'd)

4.2.2 Description of Basic Serving Arrangements (BSAs) (Cont'd)

(A) BSA-A (Cont'd)

- (10) When all BSA-A for an individual customer (a single line or entire hunt group) is discontinued at an end office, a regular number intercept announcement is provided. This arrangement provides, for a limited period of time, an announcement that the service associated with the number dialed has been disconnected.
- (11) BSA-A is provided with either Type B or Type C transmission performance. The parameters associated with these performances are guaranteed to the first point of switching. Type C transmission performance is provided with Interface Arrangement 1 and Type B is provided with Interface Arrangement 2 through 10. In addition, Data Transmission Parameters may, at the option of the customer, be provided with BSA-A.

WN U-16
Zipty Fiber

Original Sheet 153

FACILITIES FOR INTRASTATE ACCESS

4. SWITCHED ACCESS (Cont'd)

4.2 Description of Switched Access (Cont'd)

4.2.2 Description of Basic Serving Arrangements (BSAs) (Cont'd)

(B) BSA-B

Basic Serving Arrangement Alternative B (BSA-B), which is available to all customers, provides trunk-side access to Telephone Company end office switches with an associated uniform 950-1XXX or 950-0XXX access code for originating and terminating communications for customer provided interstate communications capability or connection to an interexchange interstate service.

- (1) BSA-B, when provided without the use of a Telephone Company access tandem switch (in a directly routed arrangement), is provided at all Telephone Company appropriately equipped electronic end office switches. When provided via Telephone Company appropriately equipped electronic access tandem switches, BSA-B End Office Services are provided at all Telephone Company subtending end office switches in the terminating direction and at appropriately equipped end offices in the originating direction utilizing the end user access code of 950-XXXX. For those subtending end offices that are not appropriately equipped, access in the originating direction is available by the end user access code of 1+950-XXXX.

BSA-B utilizes a two-point electrical communications path between the Interface Arrangement and Common Line or a Special Access Line, which is a voice grade transmission path comprised of any form or configuration of plant capable of, and typically used in the telecommunications industry for, the transmission of the human voice and associated telephone signals within the frequency bandwidth of approximately 300 to 3000 Hz.

- (2) BSA-B is provided as trunk-side switching through the use of end office switch trunk equipment. The switch trunk equipment is provided with wink start pulsing and answer and disconnect supervisory signaling. BSA-B may also be provided with certain Basic Service Elements (BSEs) as shown in 4.2.21.
 - (3) The Telephone Company will select the trunking arrangement from the end office within the selected Access Area from which BSA-B is to be provided. If the customer orders an Automatic Number Identification (ANI) Arrangement, as shown in 4.2.21, or Rotary Dial Station Signaling, as shown in 4.2.5(L), special routing and trunking arrangements may be required.
-

WN U-16
Zipty Fiber

Original Sheet 154

FACILITIES FOR INTRASTATE ACCESS

4. SWITCHED ACCESS (Cont'd)

4.2 Description of Switched Access (Cont'd)

4.2.2 Description of Basic Serving Arrangements (BSAs) (Cont'd)

(B) BSA-B (Cont'd)

- (4) BSA-B is arranged for either originating, terminating, or two-way calling based on the trunks or BHMC ordered. The Telephone Company will determine the type of directional calling to be provided unless the customer requests the option, Customer Specification of Switched Access Directionality as described in 4.2.5(H). For such specification, additional charges on an Individual Case Basis will apply if the calling arrangements are different from that the Telephone Company would have provided without such special arrangements. Originating calling permits the origination of calls from the end user to the CDL. Terminating calling permits the termination of calls from the CDL to the end user. Two-way calling permits either the origination or termination of calls, but not simultaneously.
 - (5) BSA-B, when being used in the terminating and originating direction, is provided with multifrequency address signaling. At the option of the customer, up to 7 Digits Outpulsing of Access Digits to the customer will be provided in the originating direction by the Telephone Company equipment to the CDL where the BSA-B terminates. Except for BSA-B provided with the ANI arrangement or Rotary Dial Station Signaling, any other address signaling in the originating direction, if required by the customer, must be provided by the end user using inband tone signaling techniques. Such inband tone address signals will not be regenerated by the Telephone Company and will be subject to the ordinary transmission capabilities of the Switched Transport provided.
 - (6) BSA-B, when being used in the terminating direction, may be used to access valid NXXs in the BSA-B Access Area. If the BSA-B connection is made directly to an end office, the Access Area is that of that end office only. If the BSA-B connection is made to an access tandem, the Access Area is that of all end offices subtending that access tandem. The description of any BSA-B Access Area will be provided to the customer upon request. Access is also available to information services (e.g., time and temperature) and IC services by dialing the appropriate digits and other services when those services can be reached using valid NXX codes. Premium End Office Switching - Unbundled (EOSU) rates in 4.5.2(H)(5) and 4.6.3(B) apply to all FGB usage originating or terminating at an equal access end office. When a provider of MTS and WATS subscribes to BSA-B and BSA-C at an end office, BSA-C usage and BSA-B terminating usage will be subject to premium EOSU rates and BSA-B originating usage will be subject to nonpremium EOSU rates.
 - (7) A separate trunk group will be established based on the directionality (i.e., originating only, terminating only, or two-way traffic) of the BSA-B arrangement provided.
-

WN U-16
ZiPLY Fiber

Original Sheet 155

FACILITIES FOR INTRASTATE ACCESS

4. SWITCHED ACCESS (Cont'd)

4.2 Description of Switched Access (Cont'd)

4.2.2 Description of Basic Serving Arrangements (BSAs) (Cont'd)

(B) BSA-B (Cont'd)

- (8) The access code for BSA-B is a uniform access code in the form of 950-XXXX. For end offices not appropriately equipped an IC may instruct their end users to access the BSA-B by dialing 1+950-XXXX.
- (9) BSA-B may, at the option of the customer, be arranged to provide an ANI arrangement to obtain the calling station billing numbers. ANI is not available if the BSA-B connection is at a Telephone Company access tandem. The ANI arrangement provides seven digit calling station billing number information to the CDL. In those situations where no billing number is available in the end office switch, as with 4/8 party service, no seven digit number will be provided and an "operator identification" information digit will be provided.

In those cases where an ANI failure has occurred in the end office switch, no seven digit number will be provided, and an "identification failure" information digit will be provided. ANI will be available using multifrequency signaling provided by the Telephone Company.

Rotary Dial Station Signaling will be made available in certain end offices using dial repeating equipment provided by the Telephone Company. The customer must order Switched Transport arranged to pass the dial repeating signals. BSA-B is provided in directly routed arrangements where the ANI or Rotary Dial Station Signaling arrangements are provided.

Only calls from end users terminated on the end office switch will be provided with the ANI or Rotary Dial Station Signaling arrangements.

- (10) The Telephone Company will determine the end office ANI protocol for BSA-B. The Telephone Company makes no guarantee that ANI will be available at all end offices which have access to BSA-B.

WN U-16
Zipty Fiber

Original Sheet 156

FACILITIES FOR INTRASTATE ACCESS

4. SWITCHED ACCESS (Cont'd)

4.2 Description of Switched Access (Cont'd)

4.2.2 Description of Basic Serving Arrangements (BSAs) (Cont'd)

(B) BSA-B (Cont'd)

(11) BSA-B is provided with basic testing at no additional charge. Basic tests include: loss, 3 tone slope, (C-message and C-notched noise) and where applicable, dc continuity, signaling and balance testing.

(a) Where Telephone Company equipment is available, a seven digit access number will be provided to the customer for testing in the terminating direction. These access numbers shall include: balance (100 type) test line, milliwatt (102 type) test line, data transmission (107 type) test line, loop around test line, short circuit test line and open circuit test line.

(b) Where Telephone Company equipment is available and the customer is equipped with compatible remote office test lines, BSA-B will be provided with automatic testing (105 type or equivalent) in the originating direction.

Additional testing charges apply as in 6.6 when: (a) the customer requests a test not specified in the preceding; (b) the test requested is not essential to the ongoing maintenance of BSA-B; or (c) the customer requests testing on a more frequent basis than scheduled in the Telephone Company's Central Office Maintenance Planning System (COMPS). The Telephone Company will routinely perform maintenance testing from its access tandem or end office (if direct routed) to the customer's first point of switching.

WN U-16
ZiPLY Fiber

Original Sheet 157

FACILITIES FOR INTRASTATE ACCESS

4. SWITCHED ACCESS (Cont'd)

4.2 Description of Switched Access (Cont'd)

4.2.2 Description of Basic Serving Arrangements (BSAs) (Cont'd)

(B) BSA-B (Cont'd)

- (12) When all BSA-B is discontinued at an end office and/or in an Access Area, a regular number intercept announcement is provided. This arrangement provides, for a limited period of time, an announcement that the BSA-B associated with the number dialed has been disconnected.
- (13) BSA-B is provided with either Type B or Type C transmission performance. The parameters associated with these performances are guaranteed to the end office, when routed directly, or to the first point of switching, when routed via an access tandem. Type C transmission performance is provided with Interface Arrangement 1 and Type B is provided with Interface Arrangements 2 through 10. In addition, Data Transmission Parameters may, at the option of the customer, be provided with BSA-B.
- (14) BSA-B may at the option of the customer and with the concurrence of the Telephone Company, be provided with Alternate Traffic Routing. This arrangement, as shown in 4.2.21, delivers originating traffic from an end office over a designated trunk group to the CDL. When that trunk group is fully loaded, additional originating traffic is automatically delivered over one or more designated trunk groups to one or more CDLs.

FACILITIES FOR INTRASTATE ACCESS

4. SWITCHED ACCESS (Cont'd)4.2 Description of Switched Access (Cont'd)4.2.2 Description of Basic Serving Arrangements (BSAs) (Cont'd)(C) BSA-C

Basic Serving Arrangement Alternative C (BSA-C) provides trunk-side access to Telephone Company end office switches for providers of MTS and WATS for originating and terminating communications. BSA-C is available in all end offices which are not equipped for FGD or BSA-D End Office Services.

- (1) BSA-C is provided at all Telephone Company end office switches or Telephone Company designated access tandem switches. BSA-C is available at an end office switch unless FGD or BSA-D is provided in the same office. When FGD or BSA-D is available, BSA-C will be discontinued as soon as the conversion to BSA-D can be arranged.

BSA-C utilizes a two-point electrical communications path between the Interface Arrangement and Common Line or Special Access Line which is a voice grade transmission path comprised of any form or configuration of plant capable of, and typically used in the telecommunications industry for, the transmission of the human voice and associated signals within the frequency bandwidth of approximately 300 to 3000 Hz.

- (2) BSA-C is provided as trunk-side switching through the use of end office switch trunk equipment. The switch trunk equipment is provided with answer and disconnect supervisory signaling. Wink start pulsing signals are provided in all offices where available. In those offices where wink start pulsing signals are not available, delay dial start pulsing signals will be provided.

BSA-C may also be provided with certain Basic Service Elements (BSEs) as shown in 4.2.21.

- (3) The Telephone Company will select the trunking arrangement from the end office within the selected Access Area from which BSA-C is to be provided. If the customer orders an ANI arrangement as shown in 4.2.21 and 4.5.9, or Service Class Routing Arrangement, special routing and trunking arrangements may be required.
 - (4) BSA-C is arranged for either originating calling only, terminating calling only, or two-way calling based on the trunks or BHMC ordered. The Telephone Company will determine the type of Directional calling to be provided unless the customer requests the option, Customer Specification of Directionality as described in 4.2.5(H). For such specification, additional charges on an Individual Case Basis will apply if the trunk group Routing arrangements are different from that the Telephone Company would have provided without such special arrangements. Originating calling permits the origination of calls from the end user to the CDL. Terminating calling permits the termination of calls from the CDL to the end user. Two-way calling permits either the origination or termination of calls, but not simultaneously.
-

FACILITIES FOR INTRASTATE ACCESS

4. SWITCHED ACCESS (Cont'd)4.2 Description of Switched Access (Cont'd)4.2.2 Description of Basic Serving Arrangements (BSAs) (Cont'd)(C) BSA-C (Cont'd)

- (5) BSA-C is provided with multifrequency address signaling except in certain electromechanical end office switches where multifrequency signaling is not available. In such electromechanical end office switches, the address signaling will be dial pulse or revertive pulse signaling, whichever is available. Dial pulse address signaling may, at the option of the customer, be provided in lieu of multifrequency address signaling if such signaling facilities are available in the end office. Up to twelve digits of the called party number dialed by the customer's end user will be provided by Telephone Company equipment to the CDL where the BSA-C terminates. Such called party number signals will be subject to the ordinary transmission capabilities of the Switched Transport provided.
- (6) BSA-C, when being used in the terminating direction, may be used to access NXXs in the BSA-C Access Area. If the BSA-C connection is made directly to an end office the Access Area is that of that end office only. If the BSA-C connection is made to a Telephone Company access tandem the Access Area is that of all end offices subtending that Telephone Company access tandem. The description of any BSA-C Access Area will be provided to the customer upon request. Access is also available to Directory Assistance and other services (by dialing the appropriate codes) when the services can be reached using valid NXX codes.
- (7) A separate trunk group will be established based on the directionality (i.e., originating only, terminating only, or two-way traffic) of the BSA-C arrangement provided.
- (8) No access code is required for BSA-C. In certain locations, due to Central Office equipment limitations, two or three digit access codes may be used. The telephone number dialed by AT&TC's end user shall be a seven or ten digit number for calls in the North American Numbering Plan (NANP). For international calls outside the NANP, a five to twelve digit number may be dialed. The form of the numbers dialed by AT&TC's end user is NXX-XXXX, 0 or 1 + NXX-XXXX, NPA + NXX-XXXX, 0 or 1 + NPA + NXX-XXXX, and, when the International Direct Distance Dialing Arrangement (IDDD) is provided, 01 + CC + NN or 011 + CC + NN.

WN U-16
Zipty Fiber

Original Sheet 160

FACILITIES FOR INTRASTATE ACCESS

4. SWITCHED ACCESS (Cont'd)

4.2 Description of Switched Access (Cont'd)

4.2.2 Description of Basic Serving Arrangements (BSAs) (Cont'd)

(C) BSA-C (Cont'd)

- (9) BSA-C may, at the option of the customer, be arranged to provide an ANI arrangement to obtain the calling station billing number. The ANI arrangement provides seven digit station billing number information to the CDL. In those situations where no billing number is available in the end office switch, as with 4/8 party service, no seven digit number will be provided and an "operator identification" information digit will be provided.

In those cases where an ANI failure has occurred in the end office switch, no seven digit number will be provided and an "identification failure" information digit will be provided. ANI will be made available using multifrequency signaling provided by the Telephone Company.

BSA-C is provided in directly routed arrangements to the end office switch where the ANI arrangement is provided. The Telephone Company will determine the end office ANI protocol for BSA-C.

Only calls from end users terminated on the end office switch will be provided with the ANI arrangement. ANI is provided from end offices for which Telephone Company recording for end user billing is not provided, or where it is not required, as with 800/877/888 Service. It is not provided from end offices for which the Telephone Company needs to forward ANI to its recording equipment.

FACILITIES FOR INTRASTATE ACCESS

4. SWITCHED ACCESS (Cont'd)

4.2 Description of Switched Access (Cont'd)

4.2.2 Description of Basic Serving Arrangements (BSAs) (Cont'd)

(C) BSA-C (Cont'd)

(10) BSA-C is provided with basic testing at no additional charge. Basic tests include: loss, 3 tone slope, (C-message and C-notched), and where applicable, signaling and balance testing.

(a) Where Telephone Company equipment is available, a seven digit access number will be provided to the customer for testing in the terminating direction. The access number shall include: balance (100 type) test line, milliwatt (102 type) test line, automatic transmission measuring (105 type) test line, data transmission (107 type) test line, nonsynchronous or synchronous test line, loop around test line, short circuit test line and open circuit test line.

(b) Where Telephone Company equipment is available and the customer is equipped with compatible equipment (remote office test lines and 105 test lines with associated responders or their functional equivalent), BSA-C will be provided with automatic testing.

(c) At the option of the Telephone Company, cooperative testing may be provided in lieu of automatic testing. Cooperative testing is where the Telephone Company provides a technician at its office(s) and the customer provides a technician at its CDL, with suitable test equipment to perform the required tests. The Telephone Company will routinely perform maintenance testing from its access tandem or end office (if direct routed) to the customer's first point of switching.

Additional testing charges will apply as in 6.6 when: (a) the customer requests a test not specified in the preceding; (b) the test requested is not essential to the ongoing maintenance of BSA-C; or (c) the customer requests testing on a more frequent basis than scheduled in the Telephone Company's Central Office Maintenance Planning System (COMPS).

WN U-16
ZiPLY Fiber

Original Sheet 162

FACILITIES FOR INTRASTATE ACCESS

4. SWITCHED ACCESS (Cont'd)

4.2 Description of Switched Access (Cont'd)

4.2.2 Description of Basic Serving Arrangements (BSAs) (Cont'd)

(C) BSA-C (Cont'd)

- (11) BSA-C may, at the option of the customer, be provided with Alternate Traffic Routing. This arrangement, as shown in 4.2.21, delivers originating traffic from an end office over a designated trunk group to the CDL. When that trunk group is fully loaded, additional originating traffic is automatically delivered over one or more designated trunk groups to one or more CDLs.
- (12) BSA-C may, at the option of the customer, be provided with a Service Class Routing Arrangement. This arrangement allows originating traffic to be delivered over selected trunk groups to specified CDL based on service prefix (e.g., 0-, 0+, 1+, 01, 011); service class codes (e.g., 500, 700, 800, 877, 888, 900); or end user originating line class of service (e.g., coin, multiparty, hotel/motel).
- (13) BSA-C may, at the option of the customer, be provided with a Trunk Access Limitation Arrangement in all Telephone Company end offices. This arrangement provides for the routing of designated (e.g., 900 Service Code) originating calls to a specified number of transmission paths in a trunk group to the CDL in order to limit the amount of such traffic that can be completed.
- (14) BSA-C is provided with the following features in the originating direction for operator assistance services. BSA-C may require the routing by Service Class Routing Arrangement.
 - (a) Operator Assistance-Coin Control Arrangements for Telephone Company end offices where equipment is available - Such arrangements provide coin return control and routing of 0+, 0-, 01+ and 011+ prefixed originating calls to the CDL. The operator services system arrangement for receipt of 0+, 0-, 1+, 01+ and 011+ calls may, at the option of the customer, be provided with the ANI arrangement. The cord board arrangement for receipt of 0- originating calls is not provided with ANI. BSA-C is provided in a directly routed arrangement where the Operator Assistance-Coin Control arrangement is provided. Only calls from coin station lines terminated on the end office switch where the Operator Assistance-Coin Control Arrangement is provided will be provided to the CDL.

Issued: July 29, 2020
Issued by ZiPLY Fiber
By Jessica Epley, Regulatory & External Affairs Director

Effective: July 31, 2020

WN U-16
ZiPLY Fiber

Original Sheet 163

FACILITIES FOR INTRASTATE ACCESS

4. SWITCHED ACCESS (Cont'd)

4.2 Description of Switched Access (Cont'd)

4.2.2 Description of Basic Serving Arrangements (BSAs) (Cont'd)

(C) BSA-C (Cont'd)

(14) (Cont'd)

- (b) Operator Assistance-Noncoin Arrangements in all Telephone Company end offices - Such arrangements provide routing of 0+, 0-, 1+, 01+, and 011+ prefixed originating calls to the CDL. This arrangement for receipt of 0+, 0-, 1+, 01+, and 011+ originating calls may, at the option of the customer, be provided with the ANI arrangement.

The cord board arrangement for receipt of 0- originating calls is not provided with ANI. BSA-C is provided in a directly routed arrangement where the Operator Assistance-Noncoin Arrangement is provided. Only calls from end users terminated on the end office switch where the Operator Assistance-Noncoin Arrangement is provided will be provided to the CDL.

- (c) Operator Assistance - Combined (coin and noncoin) Arrangements in Telephone Company end offices where equipment is available - This arrangement provides the combined features described in (a) and (b).

- (15) BSA-C is provided with either Type B or Type C transmission performance as follows: a) when routed directly to the end office, either Type B or Type C is provided; b) when routed to an access tandem, only Type B is provided; or c) Type B or Type C is provided on the transmission path from the access tandem to the end office. Type C transmission performance is provided with Interface Arrangement 1 when routed directly to an end office. Type B is provided with Interface Arrangements 2 through 10 whether routed directly to an end office or to an access tandem. In addition, Data Transmission Parameters may, at the option of the customer, be provided with BSA-C.

FACILITIES FOR INTRASTATE ACCESS

4. SWITCHED ACCESS (Cont'd)4.2 Description of Switched Access (Cont'd)4.2.2 Description of Basic Serving Arrangements (BSAs) (Cont'd)(D) BSA-D

Basic Serving Arrangement Alternative D (BSA-D), available to all customers at appropriately equipped electronic end office switches, provides trunk-side access to Telephone Company end office switches with an associated 101XXXX access code for providers of MTS/WATS and MTS/WATS-type services for originating and terminating communications for customer provided interstate communications capability or connections to an interexchange interstate service.

- (1) BSA-D utilizes a two-point electrical communications path between the Interface Arrangement and Common Line or Special Access Line which is a voice grade transmission path comprised of any form or configuration of plant capable of, and typically used in the telecommunications industry for, the transmission of the human voice and associated telephone signals within the frequency bandwidth of approximately 300 to 3000 Hz.

SS7 Out of Band Signaling for BSA-D is provided at suitably equipped Telephone Company end office or access tandem switches.

- (2) BSA-D is provided as trunk-side switching through the use of end office or Telephone Company access tandem switch trunk equipment. The switch trunk equipment is provided with answer and disconnect supervisory signaling and wink start pulsing signals except when SS7 Out of Band Signaling is specified. BSA-D may also be provided with certain Basic Service Elements as shown in 4.2.21.
 - (3) The Telephone Company will select the trunking arrangement from the end office, within the selected Access Area from which BSA-D is to be provided. If the customer orders an Automatic Number Identification (ANI) Arrangement or an Alternate Traffic Routing Arrangement, as shown in 4.2.21, Service Class Routing Arrangement; Trunk Access Limitation Arrangement; or Operator Assistance Full Feature Arrangement, special routing and trunking arrangements may be required.
 - (4) BSA-D is arranged for either originating calling only, terminating calling only, or two-way calling and is based on the trunks or BHMC ordered. The Telephone Company will determine the type of directional calling to be provided unless the customer orders an Operator Assistance Full Feature Arrangement or requests the option, Customer Specification of Switched Access Directionality as described in 4.2.5(H). For such arrangements, additional charges on an Individual Case Basis will apply if the trunking arrangements are different from that the Telephone Company would have provided without such special arrangements. Originating calling permits the origination of calls from the end user to the CDL. Terminating calling permits the termination of calls from the CDL. Two-way calling permits either the origination or termination of calls, but not simultaneously.
-

FACILITIES FOR INTRASTATE ACCESS

4. SWITCHED ACCESS (Cont'd)4.2 Description of Switched Access (Cont'd)4.2.2 Description of Basic Serving Arrangements (BSAs) (Cont'd)(D) BSA-D (Cont'd)

- (5) BSA-D is provided with multifrequency address signaling or SS7 Out of Band Signaling. Up to twelve digits of the called party number dialed by the end user will be provided by Telephone Company equipment to the CDL where the BSA-D terminates. Such address signals will be subject to the ordinary transmission capabilities of the Switched Transport provided.
 - (6) BSA-D, when being used in the terminating direction, may be used to access valid NXXs in the BSA-D Access Area. If the BSA-D connection is made directly to an end office the Access Area is that of that end office only. If the BSA-D connection is made to a Telephone Company access tandem, the Access Area is all end offices subtending that access tandem that have BSA-D capabilities. When the customer wants access to all end offices subtending that access tandem (both equal access and non equal access) a single BSA-D trunk group may be used. Traffic terminating at a non equal access end office using a BSA-D trunk group will be ordered as BSA-B or BSA-C and billed at BSA-B or BSA-C rates. Separate trunk groups for the combined use of BSA-D and BSA-B or BSA-D and BSA-C are not required. The description of any BSA-D Access Area will be provided to the customer upon request. BSA-D may also be used in the terminating direction to access information services (e.g., time and temperature) and other services by dialing the appropriate codes when the services can be reached using valid NXX codes.
 - (7) A separate trunk group will be established based on directionality (i.e., originating only, terminating only, or two-way traffic) of the BSA-D arrangement provided.
 - (8) The access code for BSA-D is a uniform access code of the form 101XXXX. No access code is required if the end user's Telephone Company local service is arranged for Primary Interexchange Carrier (PIC) arrangement as in 6.5 to the same IC. The number dialed by the end user shall be a seven or ten digit number for calls in the North American Numbering Plan (NANP). For international calls outside the NANP, a five to twelve digit number may be dialed. The form of the numbers dialed by the end users is NXX-XXXX, 0 or 1 + NXX-XXXX, NPA + NXX-XXXX, 0 or 1 + NPA + NXX-XXXX, and, when the International Direct Distance Dialing Arrangement (IDDD) is provided, 01 + CC + NN or 011 + CC + NN. When the 101XXXX access code is used, BSA-D also provides for dialing the digit 0 for access to the customer's operator, or the end-of-dialing digit (#) for cut-through access to the CDL. BSA-D also provides for the dialing of digits 00 for access on a non-DDD basis to the customer's operator when the end user's service is designated to the customer as in 6.5 and 4.2.5(V). A single access code will be the assigned number for all BSA-D provided to the customer by the Telephone Company.
-

WN U-16
ZiPLY Fiber

Original Sheet 166

FACILITIES FOR INTRASTATE ACCESS

4. SWITCHED ACCESS (Cont'd)

4.2 Description of Switched Access (Cont'd)

4.2.2 Description of Basic Serving Arrangements (BSAs) (Cont'd)

(D) BSA-D (Cont'd)

(8) (Cont'd)

In addition to the standard 101XXXX access code, the customer has the option to use 950-XXXX as an access code for FGD Switched Access Service. When the customer orders FGD Switched Access Service with 950-XXXX Access as described in 4.2.5(S), FGD switched access calls may also be originated by using the customer's 950-XXXX access code(s). All such calls will be rated as FGD switched access calls.

BSA-D, provided with multifrequency address signaling or SS7 Out of Band Signaling, is arranged to receive address signaling through the use of Dual Tone Multifrequency (DTMF) or dial pulse address signaling from the end user.

- (9) BSA-D may, at the option of the customer, be arranged to provide ANI arrangement to obtain the calling station billing number. The ANI arrangement provides ten digit station billing number information to the CDL. When SS7 Out of Band Signaling is specified, the customer may obtain an ANI equivalent by ordering the Charge Number optional feature as described in 4.2.21. In those situations where no billing number is available in the end office switch, as with 4/8 party service, no ten digit number will be provided, only the area code and an "operator identification" information digit will be provided.

In those cases where an ANI failure has occurred in the end office switch, no ten-digit number will be provided, and an "identification failure" information digit will be provided. ANI will be made available using multifrequency signaling provided by the Telephone Company.

Dependent upon the group type, the ANI spill may be forwarded prior to the called number in appropriately equipped end offices. When the ANI spill is sent prior to the called number, ten digits will be forwarded (NPA + NXX-XXXX). When the ANI spill is sent after the called number, the conventional seven digits will be forwarded. The Telephone Company will determine the sequencing and protocol of the ANI spill and called number.

FACILITIES FOR INTRASTATE ACCESS

4. SWITCHED ACCESS (Cont'd)4.2 Description of Switched Access (Cont'd)4.2.2 Description of Basic Serving Arrangements (BSAs) (Cont'd)(D) BSA-D (Cont'd)

- (10) BSA-D may, at the option of the customer, be arranged for the International Direct Distance Dialing (IDDD) Arrangement in the originating direction. End Offices or Telephone Company access tandems equipped for IDDD will be designated by the Telephone Company. The CDL must be equipped to receive the IDDD supervisory and address signals and the CDL must provide operator assistance to the end users if necessary to obtain the IDDD address signals once the CDL acknowledges it is ready to receive IDDD address signals.

BSA-D may also be arranged to forward the international calls of one or more international carriers to the customer. This arrangement requires verification by the Telephone Company that the customer is authorized to forward such calls.

- (11) BSA-D is provided with basic testing at no additional charge. Basic tests include: loss, 3 tone slope, (C-message and C-notched), and where applicable, signaling and balance testing.
- (a) Where Telephone Company equipment is available, a seven digit access number will be provided to the customer for testing in the terminating direction. These access numbers shall include: balance (100 type) test line, milliwatt (102 type) test line, nonsynchronous or synchronous test line, automatic transmission measuring (105 type) test line, data transmission (107 type) test line, loop around test line, short circuit test line and open circuit test line. Access to test lines by other than seven digits is at the option of the Telephone Company and may vary in availability.
- (b) Where Telephone Company equipment is available and the customer is equipped with compatible equipment (remote office test lines and 105 test lines with associated responders or their functional equivalent), BSA-D will be provided with automatic testing.
- (c) At the option of the Telephone Company, cooperative testing may be provided in lieu of automatic testing. Cooperative testing is where the Telephone Company provides a technician at its office(s) and the customer provides a technician at its CDL, with suitable test equipment to perform the required tests. The Telephone Company will routinely perform maintenance testing from its access tandem or end office (if direct routed) to the customer's first point of switching. Additional testing charges will apply as in 6.6 when: (a) the customer requests a test not specified in the preceding; (b) the test requested is not essential to the ongoing maintenance of BSA-D or (c) the customer requests testing on a more frequent basis than scheduled in the Telephone Company's Central Office Maintenance Planning System (COMPS).
-

FACILITIES FOR INTRASTATE ACCESS

4. SWITCHED ACCESS (Cont'd)4.2 Description of Switched Access (Cont'd)4.2.2 Description of Basic Serving Arrangements (BSAs) (Cont'd)(D) BSA-D (Cont'd)

(11) (Cont'd)

- (d) When BSA-D or 800/877/888 SAC Access service with SS7 Out of Band Signaling is ordered, network compatibility and other operational tests will be performed cooperatively by the Telephone Company and the customer at locations, dates, and times as specified by the Telephone Company in consultation with the customer. These tests are as specified in Bellcore Technical Reference Publication TR-TSV-000905. Successful completion is necessary to receive the SS7 signaling option. To protect the security of the SS7 network, certain of the information provided, i.e., point codes, by the Telephone Company to the customer will be subject to a nondisclosure agreement.
- (12) BSA-D may, at the option of the customer, be provided with Alternate Traffic Routing. This arrangement, as shown in 4.2.21, delivers originating traffic from an end office over a designated trunk group to the CDL. When that trunk group is fully loaded, additional originating traffic is automatically delivered over one or more designated trunk groups to one or more CDLs.
- (13) BSA-D may, at the option of the customer, be provided with a Service Class Routing Arrangement. This arrangement allows originating traffic to be delivered over selected trunk groups to specified CDLs based on service prefix code (e.g., 0-, 0+, 1+, 01, 011); service class codes (e.g., 500, 700, 800, 877, 888, 900); or end user originating line class of service (e.g., coin, multiparty, hotel/motel). Service classes of traffic unable to be served by a customer will be handled at the option of the Telephone Company.
- (14) BSA-D will be arranged to accept calls from Telephone Company local service without the 101XXXX uniform access code. Each Telephone Company local service will be marked to identify which 101XXXX code its calls will be directed to for InterLATA Area service.
- (15) BSA-D may, at the option of the customer, be provided with a Trunk Access Limitation Arrangement. The Trunk Access Limitation Arrangement provides for the routing of designated (e.g., 900 Service class code) originating calls to a specified number of transmission paths in a trunk group.
-

WN U-16
ZiPLY Fiber

Original Sheet 169

FACILITIES FOR INTRASTATE ACCESS

4. SWITCHED ACCESS (Cont'd)

4.2 Description of Switched Access (Cont'd)

4.2.2 Description of Basic Serving Arrangements (BSAs) (Cont'd)

(D) BSA-D (Cont'd)

- (16) BSA-D may, at the option of the customer, be provided with an Operator Assistance Full Feature Arrangement. This arrangement provides, to the customer operator, the initial coin control function. BSA-D is provided in a directly routed arrangement from the end office switch when this feature is provided. This feature may require the routing by Service Class Routing Arrangement. The coin collection and return protocol required by the customer must be compatible with Telephone Company equipment. Offering of this feature is contingent upon suitable administrative procedures/agreements for coin services being negotiated between the customer and the Telephone Company. This option is unavailable in conjunction with SS7 Out of Band Signaling.
- (17) BSA-D is provided with either Type A, Type B, or Type C transmission performance as follows: a) when routed directly to the end office, either Type B or Type C is provided; b) when routed to an access tandem, only Type A is provided; c) Type A is provided on the transmission path from the access tandem to the end office. Type C transmission performance is provided with Interface Arrangement 1. Type A and Type B are provided with Interface Arrangements 2 through 10. In addition, Data Transmission Parameters may, at the option of the customer, be provided with BSA-D.
- (18) BSA-D trunking arrangements are available with two basic forms of signaling protocol. The standard signaling protocol provided with BSA-D is Overlap Outpulsing. At the option of the customer, where technically available BSA-D may be provided with Non-Overlap Outpulsing signaling protocol.

WN U-16
ZiPLY Fiber

Original Sheet 170

FACILITIES FOR INTRASTATE ACCESS

4. SWITCHED ACCESS (Cont'd)

4.2 Description of Switched Access (Cont'd)

4.2.2 Description of Basic Serving Arrangements (BSAs) (Cont'd)

(E) Dedicated Network Access Link (DNAL)

The DNAL provides a connection between the customer designated location and the Telephone Company end office that provides the BSA-A dial tone for connection to equipment that is not part of the end office switch but that is used to provide the Simplified Message Desk Interface (SMDI) BSA. The DNAL is only available for use with the SMDI BSE.

DNAL service is either a two-wire or four-wire channel which is capable of transmitting signals within the frequency bandwidth of approximately 300 to 3000 Hz.

There are two rate elements which apply to DNALs. The entrance facility, which provides the transmission path and interface between the Telephone Company's serving wire center and the customer provided facilities at the point of termination at the CDL. If the serving wire center is not the BSA-A dial tone office, then Direct-Trunked Transport will also apply for the mileage between the serving wire center and the BSA-A dial tone office.

The rates and charges for two-wire and four-wire voiceband Entrance Facilities and Direct-Trunked Transport Facility-Voiceband apply for the DNAL Entrance Facility and DSNAL Direct-Trunked Transport, respectfully.

WN U-16
ZiPLY Fiber

Original Sheet 171

FACILITIES FOR INTRASTATE ACCESS

4. SWITCHED ACCESS (Cont'd)

4.2 Description of Switched Access (Cont'd)

4.2.3 Description of Switched Transport

(A) General

- (1) Switched Transport provides the transmission of Switched Access communications including SAC Access Service, between the CDL and the originating or terminating end office switch(es) in the Access Area with one exception. Switched Transport associated with FGA or BSA-A 1+ terminating traffic provides for the transmission of Switched Access outside the Access Area, however within the LATA. Switched Transport is comprised of the following rate elements; an Entrance Facility Rate, a Direct-Trunked Transport Rate, a Tandem-Switched Transport Rate and an Interconnection Rate.

The Entrance Facility Rate is assessed upon customers for the use of Telephone Company Voiceband, DS1 and DS3 high capacity facilities, including interface arrangements, between the point of termination at the Customer Designated Location (CDL) and the Telephone Company's serving wire center. The Entrance Facilities are further described in 4.2.3(B).

The Direct-Trunked Transport Rate is assessed upon customers for the use of Voiceband, DS1 and DS3 high capacity transport facilities dedicated to a single customer between a serving wire center and end office (including host end offices), end offices used to provide Tandem Switch Signaling, between a serving wire center and a Telephone Company Hub for multiplexing purposes, between two Telephone Company hubs, between a serving wire center and a Directory Assistance Center, between a Telephone Company Hub and an end office and between a serving wire center and a Telephone Company access tandem. The Direct-Trunked Transport Rate is flat-rated and, with the exception of Voiceband Transport, has both distance-sensitive and nondistance-sensitive components. Voiceband Direct-Trunked Transport is distance sensitive only. Direct-Trunked Transport is further described in 4.2.3(C).

WN U-16
Zipty Fiber

Original

FACILITIES FOR INTRASTATE ACCESS

4. SWITCHED ACCESS (Cont'd)

4.2 Description of Switched Access (Cont'd)

4.2.3 Description of Switched Transport (Cont'd)

(A) General (Cont'd)

(1) (Cont'd)

The Tandem-Switched Transport Rate is assessed upon customers for the use of transport between a serving wire center and an end office that is switched at a Telephone Company access tandem. The Tandem-Switched Transport Rate may also be assessed for transport between a Telephone Company access tandem and end office when the customer orders Direct-Trunked Transport to a Telephone Company access tandem¹, between a host end office and a remote end office and between a FGA or BSA-A dialtone office and other end offices in the local calling area. Tandem-Switched Transport consists of circuits dedicated to the use of a single customer from the serving wire center to the Telephone Company's access tandem and circuits used in common by multiple customers from the Telephone Company access tandem to an end office. The Tandem-Switched Transport Rate includes three subelements, a Tandem-Switched Transport - Facility, a Tandem-Switched Transport - Termination, and a Tandem Switching Rate. The Tandem Switching Rate is not applicable for transport between a host end office and a remote end office or to FGA or BSA-A Transport. Tandem-Switched Transport is further described in 4.2.3(D).

The Shared Trunk Port provides for the termination of a Tandem-Switched Trunk at an end office. The Shared Trunk Port is usage rated and shall be assessed to all access minutes, which utilize Tandem-Switched Transport. This includes minutes of use associated with FGA service when traffic is terminated in an end office that is not the dial tone office and on minutes of use provided at a remote office.

The Shared Trunk Port charge does not apply to switched access minutes of use that originate or terminate at MTSOs directly interconnected to a Telephone Company access tandem.

The Interconnection Rate is assessed upon all customers for interconnecting with the Telephone Company's switched access network. The Interconnection Rate is further described in 4.2.3(E).

The Dedicated Switched Access Transport Rate is assessed upon customers subscribing to CCS7 Access Service for the use of facilities between the customer's common channel signalling network and the Telephone Company's signalling transfer point. It is a flat rated, distance-sensitive monthly rate. This rate element is further described in 4.2.5(W).

The application of the Switched Transport rates and the determination of mileage measurements for Switched Transport is in 4.5.2(H)(2).

Note¹: Due to billing constraints, the ordering of Tandem-Switched Transport in conjunction with Direct-Trunked Transport is prohibited until the billing system can accommodate this service.

WN U-16
ZiPLY Fiber

Original Sheet 173

FACILITIES FOR INTRASTATE ACCESS

4. SWITCHED ACCESS (Cont'd)

4.2 Description of Switched Access (Cont'd)

4.2.3 Description of Switched Transport (Cont'd)

(A) General (Cont'd)

- (2) Switched Transport is a two-way voice frequency transmission path composed of facilities determined by the Telephone Company. The two-way voice frequency path permits the transport of calls in the originating direction (from the end office switch to the CDL), and in the terminating direction (from the CDL to the end office switch), but not simultaneously. The voice frequency transmission path may be comprised of any form or configuration of plant capable of and typically used in the telecommunications industry for the transmission of the human voice and associated telephone signals within the frequency bandwidth of approximately 300 to 3000 Hz. Direct-Trunked Transport and Entrance Facilities are composed of facilities as ordered by the customer.

Switched Transport facilities will be engineered and routed based on standard engineering methods, available facilities and equipment, Telephone Company traffic routing plans and the customer's order for service.

The Telephone Company will work cooperatively with the customer in determining (1) whether the first point of switching will be an end office switch or an access tandem switch, and (2) the directionality of the service.

- (3) For Tandem-Switched Transport the number of Switched Transport transmission paths provided between an end office switch and a Telephone Company access tandem are determined by the Telephone Company using standard traffic methods. The number of Switched Transport transmission paths provided between the Telephone Company access tandem and the serving wire center of the CDL are determined by the customer's order. If ordered in BHMC, the Telephone Company will determine the number of trunks, using standard traffic engineering methods. When Direct-Trunked Transport is ordered directly to a Telephone Company access tandem, facilities between the serving wire center of the CDL and the Telephone Company access tandem will be determined by the customer's order.

WN U-16
ZiPLY Fiber

Original Sheet 174

FACILITIES FOR INTRASTATE ACCESS

4. SWITCHED ACCESS (Cont'd)

4.2 Description of Switched Access (Cont'd)

4.2.3 Description of Switched Transport (Cont'd)

(B) Entrance Facilities

The Entrance Facility provides the transmission path and the interface between the Telephone Company's serving wire center and customer provided facilities at the point of termination at the CDL.

Switched Access is provided in a number of separate Entrance Facilities. Each Entrance Facility provides a specified facility interface (e.g., two-wire, four-wire, DS1, etc.). Provision of the Interface Arrangements for two-wire and four-wire voice frequency Entrance Facility and any Optional Arrangements may require placement of Telephone Company equipment [e.g., supervisory signaling equipment as described in 4.2.3(G)] on the customer's premises.

Where transmission facilities permit, the individual transmission paths between the point of termination and the first point of switching may, at the option of the customer, be provided with Optional Arrangements as in (G).

The following Standard Entrance Facilities are available:

Two-Wire VF
 Four-Wire VF
 Group Analog (existing customers only)
 Supergroup Analog (existing customers only)
 Mastergroup Analog (existing customers only)
 DS1 Digital
 DS1C Digital (existing customers only)
 DS3 Digital
 DS3C Digital (existing customers only)

The number of Entrance Facilities provided is determined by the customer's order for service.

(1) Two-Wire Voice Frequency Entrance Facility

- (a) The Two-Wire Voice Frequency Entrance Facility, except as specified in (b), provides two-wire voice frequency transmission at the point of termination at the CDL. The interface is capable of transmission signals within the frequency bandwidth of approximately 300 to 3000 Hz.

FACILITIES FOR INTRASTATE ACCESS

4. SWITCHED ACCESS (Cont'd)4.2 Description of Switched Access (Cont'd)4.2.3 Description of Switched Transport (Cont'd)(B) Entrance Facilities (Cont'd)(1) Two-Wire Voice Frequency Entrance Facility (Cont'd)

- (b) The Two-Wire interface is not provided in association with FGC, FGD, BSA-C, and BSA-D when the first point of switching is a Telephone Company access tandem. In addition, the two-wire interface is not provided in association with FGB and BSA-B when the first point of switching is a Telephone Company access tandem where two-wire terminations are not provided.
- (c) The transmission path between the point of termination at the CDL and the serving wire center may be comprised of any form or configuration of plant capable of and typically used in the telecommunications industry for the transmission of the human voice and associated telephone signals within the frequency bandwidth of 300 to 3000 Hz.
- (d) The Two-Wire interface is provided with loop supervisory signaling. When the interface is associated with FGA or BSA-A, such signaling may be loop start or ground start. When the interface is associated with FGB, FGC, FGD, BSA-B, BSA-C and BSA-D, such signaling, except for two-way calling, may be reverse battery signaling. The interface may, at the option of the customer, be provided with DX supervisory signaling or E&M supervisory signaling as in 4.2.3 (G)(1).

(2) Four-Wire Voice Frequency Entrance Facility

- (a) The Four-Wire Voice Frequency Entrance Facility provides four-wire voice frequency transmission at the point of termination at the CDL. The interface is capable of transmission of the human voice and associated telephone signals within the frequency bandwidth of approximately 300 to 3000 Hz.
 - (b) The transmission path between the point of termination at the CDL and the serving wire center may be comprised of any form or configuration of plant capable of and typically used in the telecommunications industry for the transmission of the human voice and associated telephone signals within the frequency bandwidth of 300 to 3000 Hz.
 - (c) The interface is provided with loop supervisory signaling. When the interface is associated with FGA or BSA-A, such signaling may be loop start or ground start signaling. When the interface is associated with FGB, FGC, FGD, BSA-B, BSA-C, and BSA-D, such signaling, except for two-way calling, may be reverse battery signaling. The interface may, at the option of the customer, be provided with supervisory signaling as in 4.2.3 (G)(1).
-

WN U-16
Zipty Fiber

Original Sheet 176

FACILITIES FOR INTRASTATE ACCESS

4. SWITCHED ACCESS (Cont'd)

4.2 Description of Switched Access (Cont'd)

4.2.3 Description of Switched Transport (Cont'd)

(B) Entrance Facilities (Cont'd)

(3) Group Analog Entrance Facility

- (a) The Group Analog Entrance Facility provides a group level analog transmission at the point of termination at the CDL. The interface is capable of transmitting electrical signals between the frequencies of 60 to 108 kHz, with the capability to multiplex up to 12 voice frequency transmission paths.

Between the serving wire center and the point of termination at the CDL, the Telephone Company may, at its option, provide multiplex equipment to derive 12 transmission paths of frequency bandwidth of approximately 300 to 3000 Hz.

- (b) The interface is provided with individual transmission path supervisory signaling.
- (c) The Group Analog Entrance Facility is obsolete technology and is available only to existing customers as of October 31, 1996.

(4) Supergroup Analog Entrance Facility

- (a) The Supergroup Analog Entrance Facility provides supergroup level analog transmission at the point of termination at the CDL. The interface is capable of transmitting electrical signals between the frequencies of 312 to 552 kHz, with the capability to multiplex up to 60 voice frequency transmission paths.

Between the serving wire center and the point of termination the Telephone Company may, at its option, provide multiplex equipment to derive 60 transmission paths of frequency bandwidth of approximately 300 to 3000 Hz to promote transmission efficiency, if required.

- (b) The interface is provided with individual transmission path SF supervisory signaling.
- (c) The Supergroup Analog Entrance Facility is obsolete technology and is available only to existing customers as of October 31, 1996.
-

WN U-16
Zipty Fiber

Original Sheet 177

FACILITIES FOR INTRASTATE ACCESS

4. SWITCHED ACCESS (Cont'd)

4.2 Description of Switched Access (Cont'd)

4.2.3 Description of Switched Transport (Cont'd)

(B) Entrance Facilities (Cont'd)

(5) Mastergroup Analog Entrance Facility

- (a) The Mastergroup Analog Entrance Facility provides mastergroup level analog transmission at the point of termination at the CDL. The interface is capable of transmitting electrical signals between the frequencies of 564 to 3084 kHz, with the capability to multiplex up to 600 voice frequency transmission paths.

Between the serving wire center and the point of termination at the CDL, the Telephone Company may, at its option, provide multiplex equipment to derive 600 transmission paths of frequency bandwidth of approximately 300 to 3000 Hz to promote transmission efficiency, if required.

- (b) The interface is provided with individual transmission path SF supervisory signaling.
- (c) The Mastergroup Analog Entrance Facility is obsolete technology and is available only to existing customers as of October 31, 1996.

(6) DS1 Digital Entrance Facility

- (a) The DS1 Digital Entrance Facility provides DS1 level digital transmission at the point of termination at the CDL. The interface is capable of transmitting electrical signals at 1.544 Mbps, with the capability to multiplex up to 24 voice frequency transmission paths.

Between the first point of switching and the point of termination at the CDL, when analog switching utilizing analog terminations is provided, the Telephone Company may, at its option, provide multiplex equipment to derive 24 transmission paths of frequency bandwidth of approximately 300 to 3000 Hz. When digital switching or analog switching with digital carrier terminations is provided, the Telephone Company will provide, at the customer's request, at the first point of switching, DS1 signals in D4 or D3 format.

- (b) The interface is provided with individual transmission path bit stream supervisory signaling.
-

WN U-16
ZiPLY Fiber

Original Sheet 178

FACILITIES FOR INTRASTATE ACCESS

4. SWITCHED ACCESS (Cont'd)

4.2 Description of Switched Access (Cont'd)

4.2.3 Description of Switched Transport (Cont'd)

(B) Entrance Facilities (Cont'd)

(7) DS1C Digital Entrance Facility

- (a) The DS1C Digital Entrance Facility provides a DS1C level digital transmission at the point of termination at the CDL. The interface is capable of transmitting electrical signals at 3.152 Mbps, with the capability to multiplex up to 48 voice frequency transmission paths.

Between the first point of switching and the point of termination, when analog switching utilizing analog terminations is provided, the Telephone Company may, at its option, provide multiplex equipment to derive up to 48 voice frequency transmission paths of frequency bandwidth of approximately 300 to 3000 Hz. When digital switching or analog switching with digital carrier terminations is provided, the Telephone Company will provide, at the first point of switching, DS1 signals in D4 or D3 format.

- (b) The interface is provided with individual transmission path bit stream supervisory signaling.
- (c) As of October 31, 1996, the DS1C Digital Entrance Facility is available to existing customers only.

(8) DS2 Digital Entrance Facility

The Telephone Company currently does not offer the DS2 Entrance Facility.

(9) DS3 Digital Entrance Facility

- (a) The DS3 Digital Entrance Facility provides, on a protected basis, a DS3 level digital transmission at the point of termination at the CDL. The interface is capable of transmitting electrical signals at 44.736 Mbps, with the capability to multiplex up to 672 voice frequency transmission paths.

Between the first point of switching and the point of termination at the CDL, when analog switching utilizing analog terminations is provided, the Telephone Company may, at its option, provide multiplex equipment to derive up to 672 voice frequency transmission paths of frequency bandwidth of approximately 300 to 3000 Hz. When digital switching or analog switching with digital carrier terminations is provided, the Telephone Company will provide, at the customer's request, at the first point of switching, DS3 signals in D4 or D3 format.

WN U-16
Zipty Fiber

Original Sheet 179

FACILITIES FOR INTRASTATE ACCESS

4. SWITCHED ACCESS (Cont'd)

4.2 Description of Switched Access (Cont'd)

4.2.3 Description of Switched Transport (Cont'd)

(B) Entrance Facilities (Cont'd)

(9) DS3 Digital Entrance Facility (Cont'd)

- (b) The interface is provided with individual transmission path bit stream supervisory signaling.
- (c) To insure compatibility of transmission, the utilization of the same manufacturer's equipment (end-to-end) may be required. The Telephone Company reserves the right to choose this equipment.
- (d) The customer may specify either an electrical or optical interface as described in 3.1.1(F).

(10) DS3C Digital Entrance Facility

- (a) The DS3C Digital Entrance Facility provides a DS3C level digital transmission at the point of termination at the CDL. The interface is capable of transmitting electrical signals at 89.472 Mbps, with the capability to multiplex up to 1344 voice frequency transmission paths.

Between the first point of switching and the point of termination at the CDL, when analog switching utilizing analog terminations is provided, the Telephone Company may, at its option, provide multiplex equipment to derive up to 1344 voice frequency transmission paths of frequency bandwidth of approximately 300 to 3000 Hz. When digital switching or analog switching with digital carrier terminations is provided, the Telephone Company will provide, at the customer's request, at the first point of switching, DS1 signals in D4 or D3 format.

- (b) The interface is provided with individual transmission path bit stream supervisory signaling.
 - (c) To insure compatibility of transmission, the utilization of the same manufacturer's equipment (end-to-end) may be required. The Telephone Company reserves the right to choose this equipment.
 - (d) As of October 31, 1996, the DS3C Entrance Facility is available to existing customers only.
-

FACILITIES FOR INTRASTATE ACCESS

4. SWITCHED ACCESS (Cont'd)4.2 Description of Switched Access (Cont'd)4.2.3 Description of Switched Transport (Cont'd)(C) Direct-Trunked Transport

The Direct-Trunked Transport rate is assessed upon customers for the use of Voiceband, DS1 or DS3 High Capacity transport dedicated to a customer from a serving wire center to an end office (including host end offices) when such facilities are not switched through a Telephone Company access tandem. Direct Trunked Transport also provides for the transmission facilities between:

- a serving wire center or end office and a Telephone Company Hub office other than the serving wire center where multiplexing is performed;
- a serving wire center and a Directory Assistance center where Directory Assistance services are provided as described in 15.1.1.
- a serving wire center and a Telephone Company access tandem for Tandem-Switched Transport services when Direct-Trunked Transport routing is desired directly to the Telephone Company access tandem.
- and a serving wire center and end office where Tandem Switch Signaling is provided as described in 4.2.5(A) (A) and 4.2.20.

The Direct-Trunked Transport Rate is flat-rated and has both distance-sensitive and nondistance-sensitive components. The distance-sensitive mileage recovers costs of the transmission facilities, including intermediate transmission circuit equipment, between the end points of the circuit. There are two non-distance sensitive components; the termination, which recovers costs of circuit equipment at the ends of the transmission links, and the trunk port component which recovers costs of the trunk ports. A Dedicated Trunk Port charge shall be assessed on a per voicegrade or DS1 channel terminating at an end office or access tandem. Direct-Trunked Transport is not provided at Telephone Company end offices that are not capable of measuring switched access minutes of use. These end offices are specified in NECA Tariff FCC No. 4.

FACILITIES FOR INTRASTATE ACCESS

4. SWITCHED ACCESS (Cont'd)4.2 Description of Switched Access (Cont'd)4.2.3 Description of Switched Transport (Cont'd)(D) Tandem-Switched Transport

The Tandem-Switched Transport Rate is assessed upon customers for the use of transport from a serving wire center to an end office that is switched at a Telephone Company access tandem. The Tandem-Switched Transport rate may also be assessed for transport between a Telephone Company access tandem and end office, between a host end office and a remote end office and between a FGA dial tone office and other end offices in the local calling area. Tandem-Switched Transport consists of circuits dedicated to the use of a single customer from the serving wire center to the Telephone Company access tandem and circuits used in common by multiple customers from the Telephone Company access tandem to an end office. When Tandem Switched Transport to a terminating carrier's end office, and not an end office owned by a Telephone ILEC Company, the Terminating Tandem 3rd Party and Dedicated Trunk Port rates are applicable.

The Tandem-Switched Transport Rate includes three subelements, a Tandem-Switched Transport - Facility, a Tandem-Switched Transport - Termination, and a Tandem Switching Rate. The Tandem-Switched Transport - Facility is usage rated and distance-sensitive, i.e., a per access minute per airline mile rate. The rate recovers costs of the transmission facilities, including intermediate transmission circuit equipment, between the end points of the circuit. The Tandem-Switched Transport - Termination is a usage rated, per minute rate to recover costs incurred at the ends of the transmissions links. The Tandem Switching Rate is a usage rated, per minute rate to recover a portion of the tandem switching costs. The Tandem Switching Rate is not applicable for transport between a host end office and a remote end office or to FGA Transport.

(E) Interconnection Rate

The Interconnection Rate is assessed upon all customers for interconnecting with the Telephone Company's switched access network. It is a usage rated per minute rate and applies to all originating and terminating minutes of use whether transported via Direct-Trunked Transport, Tandem-Switched Transport or Entrance Facilities.

FACILITIES FOR INTRASTATE ACCESS

4. SWITCHED ACCESS (Cont'd)4.2 Description of Switched Access (Cont'd)4.2.3 Description of Switched Transport (Cont'd)(F) Multiplexing Arrangement

Multiplexing provides for arrangements to convert a single higher capacity or bandwidth circuit for bulk transport to several lower capacity or bandwidth circuits. Monthly rates and nonrecurring charges for multiplexing apply as follows: 1) the DS3/DS1 Multiplexing Charge applies to all DS3 to DS1 multiplexing arrangements; 2) the DS1/Voice Multiplexing Charge applies to all DS1 Entrance Facility and Direct-Trunked Transport circuits that terminate in an analog office and where the multiplexer performs DS1/Voice multiplexing functions; 3) a Multiplexing Charge will always apply on High Capacity shared use switched and special access facilities.

Listed below are the multiplexing arrangements offered with switched access.

- DS1 to Voice

An arrangement that multiplexes twenty-four voice grade circuits to a single DS1 digital circuit at a rate of 1.544 Mbps, or multiplexes a single DS1 digital circuit at a rate of 1.544 Mbps to twenty-four voice grade circuits.

- DS3 to DS1

An arrangement that multiplexes twenty-eight DS1 digital circuits to a single DS3 digital circuit at rate of 44.736 Mbps, or multiplexes a single DS3 digital circuit at a rate of 44.736 Mbps to twenty-eight DS1 digital circuits.

(G) Optional Arrangements

- (1) The Telephone Company will provide Optional Arrangements in association with the Entrance Facilities listed in 4.2.3(B)(1) and 4.2.3(B)(2). The provision of such Optional Arrangements may require placement of Telephone Company equipment on the customer's premises. These Optional Arrangements are nonchargeable.

WN U-16
ZiPLY Fiber

Original Sheet 183

FACILITIES FOR INTRASTATE ACCESS

4. SWITCHED ACCESS (Cont'd)

4.2 Description of Switched Access (Cont'd)

4.2.3 Description of Switched Transport (Cont'd)

(G) Optional Arrangements (Cont'd)

(1) (Cont'd)

(a) Supervisory Signaling

A supervisory signaling capability is provided for each Entrance Facility as listed in 4.2.3(B)(1) and 4.2.3(B)(2). Where the transmission parameters allow and where signaling conversion is required by the customer to meet his signaling capability, the customer may order a supervisory signaling arrangement for each transmission path provided as follows:

For Entrance Facilities (1) and (2)

DX Supervisory Signaling arrangement, or
E&M Type I Supervisory Signaling
arrangement, or E&M Type II
Supervisory Signaling arrangement.

For Entrance Facility (2)

SF Supervisory Signaling arrangement, or
E&M Type III Supervisory Signaling arrangement.

These optional supervisory signaling arrangements are unavailable with SS7 Out of Band Signaling as described in 4.2.5(W).

FACILITIES FOR INTRASTATE ACCESS

4. SWITCHED ACCESS (Cont'd)

4.2 Description of Switched Access (Cont'd)

4.2.4 Description of End Office Services

End Office Services provide the end user termination functions and end office switching necessary to complete the transmission of Switched Access communications to and from the end users served by the end office. Standard Arrangements for End Office Services include End Office Switching. End Office Services Optional Arrangements are available as defined in 4.2.5.

End Office Services are provided in association with Switched Transport when ordered as described in Section 3. End Office Services will be provided as one of the following types: FGA, FGB, FGC, FGD, BSA-A, BSA-B, BSA-C, BSA-D and SAC Access Service.

The number of End Office Service transmission paths and line terminations provided will be determined by the Telephone Company based on standard traffic engineering methods.

End Office Switching provides the following:

- The facilities to terminate end user Common Lines in end office switches or Special Access Lines in WATS Serving Offices.
- The end office switching functions necessary to complete a Switched Access communication to or from end user Common Lines or Special Access Lines served by the end office.
- The termination of a call at a Telephone Company intercept operator or recording. The operator or recording tells a caller why a call, as dialed, could not be completed, and if possible, provides the correct number.

End Office Switching is divided into two categories; End Office Switching - Bundled (EOSB) and End Office Switching Unbundled (EOSU). Application of the charges is in 4.5.2(H)(5) and the rates are in 4.6.3(A) and (B).

WN U-16
ZiPLY Fiber

Original Sheet 185

FACILITIES FOR INTRASTATE ACCESS

4. SWITCHED ACCESS (Cont'd)

4.2 Description of Switched Access (Cont'd)

4.2.5 End Office Services Optional Arrangements

The following optional arrangements are available in offices where equipment, facilities, and other conditions permit. The Telephone Company makes no guarantee that these optional arrangements will be available in all locations.

Unless otherwise noted, the End Office Services Optional Arrangements are nonchargeable.

(A) Alternate Traffic Routing

This option provides the capability of directing originating traffic from an end office (or appropriately equipped access tandem) via a trunk group (the "high usage" group) to a CDL until that group is fully loaded, and then delivering additional originating traffic (the "overflowing" traffic) from the same end office or access tandem to a different trunk group or groups (via one or more intermediate high usage groups) to one or more CDL's until the originating traffic is directed to a final group. The customer shall specify the last trunk CCS desired for the high usage group and each intermediate group.

This option is provided in suitably equipped end office or access tandem switches and is available with FGB, FGC and FGD.

This option is available with BSA-B, BSA-C and BSA-D as a chargeable BSE as specified in 4.2.21 and 4.5.9.

WN U-16
ZiPLY Fiber

Original Sheet 186

FACILITIES FOR INTRASTATE ACCESS

4. SWITCHED ACCESS (Cont'd)

4.2 Description of Switched Access (Cont'd)

4.2.5 End Office Services Optional Arrangements (Cont'd)

(B) Automatic Number Identification (ANI) Arrangement

This option provides the automatic transmission of a seven or ten digit number and information digit to the CDL for calls originating in the Access Area to identify the calling station. The ANI Arrangement will be associated with all individual transmission paths in a trunk group when this arrangement is provided.

These information digits shall only be used for billing and collection, routing, screening and completion of the originating subscriber's call or transaction or for service directly related to the originating subscriber's call or transaction.

The ANI provided shall not be reused or resold without first notifying the originating telephone subscriber and obtaining affirmative consent of the subscriber for reuse or resale.

Unless the originating subscriber has given consent for the reuse or resale, any information provided shall not be used for any purpose other than:

- performing the services or transactions that are subject of the originating subscriber's call;
- ensuring network performance security, and the effectiveness of call delivery;
- compiling, using and disclosing aggregate information; and,
- complying with applicable laws.

The above restrictions shall not prevent the subscriber to the ANI Arrangement from using information acquired from an ANI Arrangement, such as the telephone number or information derived from analysis of the characteristics of calls received through the ANI Arrangement, to offer a product or service that is directly related to the products or services previously purchased by a customer of the ANI Arrangement subscriber.

The seven digit ANI telephone number is available with FGB and FGC. It will be transmitted on all calls except those identified as a multiparty line or ANI failure. The ten digit ANI telephone number is only available with FGD. When FGD with SS7 Out of Band Signaling is specified, the customer may order an ANI equivalent by ordering the Charge Number optional feature as described in 4.2.5(2). The ten digit ANI telephone number consists of the Numbering Plan Area (NPA) plus the seven digit ANI telephone number. The ten digit ANI telephone number will be transmitted on all calls except those identified as a multiparty line or ANI failure in which case only the NPA will be transmitted (in addition to the information digit described below). The ANI number for End User FIA (Common Lines) is the listed telephone number of the end user that originates the call.

WN U-16
Zipty Fiber

Original Sheet 187

FACILITIES FOR INTRASTATE ACCESS

4. SWITCHED ACCESS (Cont'd)

4.2 Description of Switched Access (Cont'd)

4.2.5 End Office Services Optional Arrangements (Cont'd)

(B) Automatic Number Identification (ANI) Arrangement (Cont'd)

With FGC, ANI is provided from end offices at which the Telephone Company recording for end user billing is not provided, or where it is not required, as with 800/877/888 Service. It is not provided from end offices for which the Telephone Company needs to forward ANI to its recording equipment.

Where ANI cannot be provided (e.g., on calls from two, and in some instances four, party service) information digits will be provided to the customer. The information digits are used in the following situations:

- (1) Telephone number is the station billing number - no special treatment is required.
- (2) Multiparty line telephone number is a two or four party line and cannot be identified - number must be obtained via an operator or in some other manner.
- (3) ANI failure has occurred in the end office switch which prevents identification of calling telephone number - number must be obtained by operator or in some other manner.

WN U-16
ZiPLY Fiber

Original Sheet 188

FACILITIES FOR INTRASTATE ACCESS

4. SWITCHED ACCESS (Cont'd)

4.2 Description of Switched Access (Cont'd)

4.2.5 End Office Services Optional Arrangements (Cont'd)

(B) Automatic Number Identification (ANI) Arrangement (Cont'd)

- (4) The configuration of the line requires special screening or handling by the customer, or
- (5) Call is an Automatic Identified Outward Dialed (AIOD) call from end user terminal equipment.

These ANI information digits are available with FGB, FCC, and FGD only. In addition, the following information digits are available with FGD only:

- (a) InterLATA Area restricted - telephone number is identified line.
- (b) InterLATA Area restricted - line requires special screening or handling by the customer.

These information digits will be transmitted as agreed to by the customer and the Telephone Company.

The ANI arrangement is available with BSA-B, BSA-C and BSA-D as a chargeable BSE as specified in 4.2.21 and 4.5.9.

(C) Intra Access Area Call Denial on Line or Hunt Group

This option allows for the screening of terminating FGA and BSA-A calls. The following screening arrangements are available with this option:

- (1) Screening of terminating calls for completion to only 411, 611, 911, 555-1212 all valid NXXs associated with the end offices within the LATA, i.e., the call cannot be further switched or routed out of the LATA.
- (2) Screening of terminating calls within the FGA or BSA-A Access Area for completion to only 411, 611, 911, 800, 877, 888, 555-1212, and a Telephone Company specified set of NXXs within the Telephone Company local exchange calling area of the dial tone office in which the arrangement is provided.

All other calls are routed to a reorder tone or recorded announcement. Arrangement 1 is provided where available. Arrangement 2 is provided in all Telephone Company electronic end offices and, where available, in electromechanical end offices. These options are available with Feature Group A or BSA-A.

WN U-16
ZiPLY Fiber

Original Sheet 189

FACILITIES FOR INTRASTATE ACCESS

4. SWITCHED ACCESS (Cont'd)

4.2 Description of Switched Access (Cont'd)

4.2.5 End Office Services Optional Arrangements (Cont'd)

(D) InterLATA Call Denial on Line or Hunt Group

This option allows for the screening of terminating calls and for completion only of calls within the LATA. All other calls are routed to an appropriate access announcement. Specifically, this option would block terminating calls to the following:

- InterLATA, dialed as either 7D, 10D, 1+7D, 1+10D, 950-XXXX, 101XXXX+7D, or 101XXXX+10D
- Service Access Codes (500, 700, 800, 877, 888 and 900)
- International, dialed as either 011 or 01
- Operator, dialed as either 0+, 0- or 00

This arrangement is provided in Telephone Company end offices, where available. It is available with FGA or BSA-A at rates and charges as described in Section 4.5.2(A)(3)(j). Blocking of the 800/877/888 Service Access Code may not be available in all end offices where this arrangement is otherwise available.

(E) Call Denial on Line or Hunt Group Outside of the Access Area

This option allows for the screening of terminating calls and for completion only of calls within the Access Area. All other calls are routed to an appropriate access announcement. Specifically, this option would block terminating calls to the following:

- Outside the Access Area, dialed as either 7D, 10D, 1+7D, 1+10D, 950-XXXX, 101XXXX+7D, or 101XXXX+10D, Service Access Codes (500, 700, 800, 877, 888 and 900)
- International, dialed as either 011 or 01
- Operator, dialed as either 0+, 0- or 00

This arrangement is provided in Telephone Company end offices, where available. It is available with FGA or BSA-A at rates and charges as described in Section 4.5.2(A)(3)(i). Blocking of the 800/877/888 Service Access Code may not be available in all end offices where this arrangement is otherwise available.

FACILITIES FOR INTRASTATE ACCESS

4. SWITCHED ACCESS (Cont'd)4.2 Description of Switched Access (Cont'd)4.2.5 End Office Services Optional Arrangements (Cont'd)(F) Dual Tone Multifrequency Address Signaling

This option allows reception of called party address signals from the customer in the form of Dual Tone Multifrequency (DTMF) signals. It is provided in all Telephone Company end offices where available. When FGA or BSA-A arrangements are provided as part of a hunt group or uniform call distribution group, and the customer requires DTMF address signaling, then all arrangements in the hunt group or uniform call distribution group will be so equipped. It is available with FGA or BSA-A.

(G) Hunt Group Arrangement

The Hunt Group Arrangement is available with FGA as a nonchargeable option. This feature is available with BSA-A as a chargeable BSE as specified in 4.2.21.

(1) This option provides the ability to sequentially access one of two or more line side connections in the originating direction, when the access code of the line group is dialed. This arrangement contemplates one access code (i.e., telephone number) per arrangement.

(2) This option provides the ability to sequentially access one of two or more lines in the terminating direction, when the hunting number of the line group is forwarded from the customer to the Telephone Company.

(H) Customer Specification of Switched Access Directionality

This option allows the customer to specify the directionality of the trunk group (i.e., originating, terminating, or two-way) in lieu of Telephone Company specification. It is available with all Feature Groups and Basic Serving Arrangements. Rates and charges will be developed on an Individual Case Basis.

(I) Nonhunting Number for Use with Hunt Group Arrangement

This option provides an arrangement for an individual line within a multiline hunt group that provides access to that line within the hunt group when it is idle or provides busy tone when it is busy, when the nonhunting number is dialed. Where available, this arrangement is provided with originating use for FGA, BSA-A or terminating use for Special Access Lines.

FACILITIES FOR INTRASTATE ACCESS

4. SWITCHED ACCESS (Cont'd)4.2 Description of Switched Access (Cont'd)4.2.5 End Office Services Optional Arrangements (Cont'd)(J) Nonhunting Number for Use with Uniform Call Distribution Arrangement

This option provides an arrangement for a uniform call distribution multiline hunt group that provides access to an individual line within the hunt group when it is idle or provides busy tone when it is busy, when the nonhunting number is dialed. Where available, this arrangement is provided with originating use for FGA, BSA-A and terminating use for Special Access Lines. It can only be provided from suitably equipped stored program controlled switches.

(K) Operator Assistance Full Feature Arrangement

This option, which is available only on a direct trunking arrangement, provides the initial coin return control function to the customer's operator. It is available with FGD or BSA-D. Rates and charges will be developed on an Individual Case Basis. This option is unavailable with SS7 Out of Band Signaling.

(L) Rotary Dial Station Signaling

This option provides for the transmission of called party address signaling from rotary dial stations to the CDL for originating calls. It is available with FGB or BSA-B where conditions permit.

(M) Service Class Routing

This option provides the capability of directing originating traffic from an end office to a CDL, based on the service prefix code (e.g., 0+ or 01+) or service class code (e.g., 500, 600, 700, 800, 877, 888 or 900). It is provided in suitably equipped end office or Telephone Company access tandem switches and is available with FGC, FGD, BSA-C and BSA-D. Originating 500-NXX-XXXX calls are routed in accordance with the 500 Customer Identification Function described in 4.2.19. Originating 800-NXX-XXXX, 877-NXX-XXXX or 888-NXX-XXXX calls are routed in accordance with the 800/877/888 Customer Identification Function as described in 4.2.10.

FACILITIES FOR INTRASTATE ACCESS

4. SWITCHED ACCESS (Cont'd)4.2 Description of Switched Access (Cont'd)4.2.5 End Office Services Optional Arrangements (Cont'd)(N) Service Code Denial on Line or Hunt Group

This option allows for the screening of terminating calls within the Access Area and for disallowing completion of calls to 0- and N11 (e.g., 411, 611 and 911). Where available this arrangement is provided in Telephone Company end offices. It is available with FGA or BSA-A and can only be provided from suitably equipped stored program controlled switches.

(O) Trunk Access Limitation

This option provides for the routing of originating 900 or 900 like Service calls to a specified number of transmission paths in a trunk group, to limit (choke) the completion of such traffic to a customer. Calls to the designated service which could not be completed over the subset of transmission paths in the trunk group (i.e., the choked calls) would be routed to reorder tone. It is available with FGC, FGD, BSA-C and BSA-D.

(P) Uniform Call Distribution Arrangement

This option provides a type of multiline hunting arrangement which provides for an even distribution of calls among the available lines in a hunt group. Where available, this arrangement is provided with originating use for FGA and terminating use for Special Access Lines.

Uniform Call Distribution is available with BSA-A as a chargeable BSE as specified in 4.2.21 and 4.5.9.

(Q) Up to Seven Digit Outpulsing of Access Digits to the Customer

This option provides for the end office capability of providing up to seven digits of the access code to the CDL. The customer can request that only some of the digits in the access code be forwarded. The access code digits would be provided to the CDL using multifrequency signaling, and transmission of the digits would precede the forwarding of ANI if that arrangement was provided. It is available with FGB and BSA-B in suitably equipped end offices.

(R) Band Advance Arrangement

This arrangement is available for Special Access Lines used with a Switching Interface. This option, which is provided in association with two or more groups, provides for the automatic overflow of terminating calls from a line group, that has exceeded its call capacity, to another line group with equal or greater number of bands than that of the overflowing line group. This arrangement does not provide for call overflow from a group with a higher band designation to one with a lower band designation.

FACILITIES FOR INTRASTATE ACCESS

4. SWITCHED ACCESS (Cont'd)4.2 Description of Switched Access (Cont'd)4.2.5 End Office Services Optional Arrangements (Cont'd)(S) FGD and BSA-D Switched Access with 950-XXXX Access

FGD or BSA-D Switched Access with 950-XXXX Access is an optional arrangement that provides for the routing of originating calls using a customer's 950-XXXX access code(s) to the customer over the customer's FGD or BSA-D trunks. All such calls will be rated as FGD or BSA-D switched access calls.

This optional arrangement, available where technically feasible in equal access end offices, uses FGD or BSA-D signaling protocols and technical specifications. The 950-XXXX traffic can be routed over FGD or BSA-D trunks combined with the customer's standard FGD or BSA-D traffic directly to the CDL or through a Telephone Company access tandem to the CDL. The customer must be able to differentiate standard FGD or BSA-D calls from 950-XXXX calls delivered over the same FGD or BSA-D trunks. FGD or BSA-D Switched Access with 950-XXXX is not available with certain Telephone Company Access tandem switches when the signaling from an end office to the Telephone Company Access tandem is multifrequency address signaling and the signaling from the Telephone Company Access tandem to the CDL is SS7 Out of Band signaling. The customer may not have originating FGD or BSA-D switched access with 950-XXXX access and originating FGB or BSA-D switched access in the same end office utilizing the same 950-XXXX Customer Identification Code.

(T) Operator Assistance for SAC Access Service

This option provides for operator completion of N00-NXX-XXXX type calls which are generated by an end user by dialing 0-. This option is available with SAC Access Service and with FGC, FGD, BSA-C and BSA-D which are used with SAC Access Service.

(U) Switched Access Interface

This arrangement is only available from Telephone Company designated end offices which are identified as WATS Serving Offices (WSO) in NECA Tariff FCC No. 4. Technical limitations resident in certain end office switches may preclude the availability of certain Switched Access Interface features. Depending on the configuration selected below, the Telephone Company will provide such services from the closest WATS Serving Office that is technically equipped to provide such services. Special Access Transport charges as described in 5.1.1(B)(2) will be applicable to the WATS Serving Office appropriately equipped for the service feature requested.

WN U-16
Zipty Fiber

Original Sheet 194

FACILITIES FOR INTRASTATE ACCESS

4. SWITCHED ACCESS (Cont'd)

4.2 Description of Switched Access (Cont'd)

4.2.5 End Office Services Optional Arrangements (Cont'd)

(U) Switched Access Interface (Cont'd)

The Switched Access portion of this arrangement is available from Section 4 of this tariff, except as described in (5), and provides connectivity from the Telephone Company's WATS Serving Office to the CDL of the customer. The Special Access portion of this feature is available from Section 5 of this tariff and provides connectivity from the Telephone Company's WATS Serving Office to the end user's CDL.

Switched Access Interface Service is available in the following configurations/features:

(1) Originating Only Feature

The Intrastate Originating Only feature is available from appropriately equipped WATS Serving Offices on a per line basis and provides for the transporting of intrastate calls from a special access line to the customer via either FGA, FGB, FGC, FGD, BSA-A, BSA-B, BSA-C or BSA-D switched access. It is provided in the following two arrangements:

(a) Restricted Geographic Screening Arrangement - Originating Only

This arrangement provides the ability to screen a dialed number by NPA and/or NXX on the basis of a geographical band which is in accordance with an end user's service agreement with the customer. The geographical bands available are those in effect as of the effective date of this tariff provision. The customer must provide the Telephone Company with the band information required for each Special Access Line subscribed to this service.

This arrangement is provided when used exclusively for intrastate traffic. This arrangement is not available for a Multi-jurisdictional traffic (combined interstate and intrastate) as described in 4.2.5 (U) (1) (b).

WN U-16
ZiPLY Fiber

Original Sheet 195

FACILITIES FOR INTRASTATE ACCESS

4. SWITCHED ACCESS (Cont'd)

4.2 Description of Switched Access (Cont'd)

4.2.5 End Office Services Optional Arrangements (Cont'd)

(U) Switched Access Interface (Cont'd)

(1) Originating Only Feature (Cont'd)

(a) Restricted Geographical Screening Arrangement - Originating Only
(Cont'd)

This arrangement is available from appropriately equipped WATS Serving Offices with FGC, FGD, BSA-C and BSA-D and provides for:

- the transporting of all intrastate 1+NPA-NXX-XXXX calls and 1+FNPA-555-1212 calls to Directory numbers that are associated with a customer selected geographic band to the customer;
- the blocking of all 1+NPA-NXX-XXXX and 1+FNPA-NXX-XXXX calls directed to Directory numbers that do not lie within the geographic band selected by the customer;
- the blocking of all 1+500+NXX-XXXX, 1+700-NXX-XXXX, 1+800-NXX-XXXX, 1+877-NXX-XXXX, 1+888-NXX-XXXX and 1+900-NXX-XXXX calls;
- the blocking of all O+NPA-NXX-XXXX calls;
- the transporting of all calls originated by dialing 0 (zero) to the Telephone Company operator.
- the transport of all calls originated by dialing 00 (zero, zero) to the IC (available only with FGD); and
- the blocking of all calls preceded by the access code 101XXXX.

WN U-16
Zipty Fiber

Original Sheet 196

FACILITIES FOR INTRASTATE ACCESS

4. SWITCHED ACCESS (Cont'd)

4.2 Description of Switched Access (Cont'd)

4.2.5 End Office Services Optional Arrangements (Cont'd)

(U) Switched Access Interface (Cont'd)

(1) Originating Only Feature (Cont'd)

(b) Unrestricted Arrangement - Originating Only

This arrangement is a multi-jurisdictional offering provided from a Telephone Company WATS Serving Office and provides for the transporting of interstate and intrastate calls from a Special Access Line to the customer via FGA, FGB, FGC, FGD, BSA-A, BSA-B, BSA-C or BSA-D Switched Access. FGA or BSA-A access is obtained from a WATS Serving office by dialing a standard seven digit number. FGB or BSA-B access is obtained from a WATS Serving Office by dialing 950-XXXX or 1+950-XXXX. The combining of interstate and intrastate will be in accordance with 4.2.5(6)(5). This arrangement provides for transporting the following types of calls:

- 1+NPA-NXX-XXXX, 1+700-NXX-XXXX and 1+FNPA 555-1212 calls to the IC or designated intraLATA toll carrier;
- 1+800-NXX-XXXX, 1+877-NXX-XXXX or 1+888-NXX-XXXX calls to the carrier in accordance with the 800/877/888 Customer Identification Function described in 4.2.10;
- 1+900-NXX-XXXX calls to the carrier in accordance with 900 Customer Identification Function described in 4.2.11.
- 1+500-NXX-XXXX calls to the carrier in accordance with the 500 Customer Identification Function described in 4.2.19.

WN U-16
ZiPLY Fiber

Original Sheet 197

FACILITIES FOR INTRASTATE ACCESS

4. SWITCHED ACCESS (Cont'd)

4.2 Description of Switched Access (Cont'd)

4.2.5 End Office Services Optional Arrangements (Cont'd)

(U) Switched Access Interface (Cont'd)

(1) Originating Only Feature (Cont'd)

(b) Unrestricted Arrangement - Originating Only (Cont'd)

- 0+NPA-NXX-XXXX calls to the IC or the designated intraLATA carrier;
- calls originated by dialing 0 (zero) to the Telephone Company operator;
- calls originated by dialing 00 (zero, zero) to the IC (available only with FGD)
- calls originated by dialing 01 or 011 to the IC and
- 1+ or 0 (zero)+NPA-NXX-XXXX calls preceded by the access code 101XXXX to the carrier designated by the dialed digits (available only with FGD or BSA-D).

Optional Access Code Arrangements

Subject to technical availability, on an individual line basis, calls preceded by the access code 101XXXX will be blocked.

WN U-16
ZiPLY Fiber

Original Sheet 198

FACILITIES FOR INTRASTATE ACCESS

4. SWITCHED ACCESS (Cont'd)

4.2 Description of Switched Access (Cont'd)

4.2.5 End Office Services Optional Arrangements (Cont'd)

(U) Switched Access Interface (Cont'd)

(2) 800/877/888 Type Terminating Only Feature

The 800/877/888 Type Intrastate Terminating Only feature is available on a per-line basis from appropriately equipped WATS Serving Offices and provides for the termination of all calls from the subscribing carrier (originated on a 1+800, 1+877 and 1+888 basis) directed to the Special Access via FGA, FGB, FGC, FGD, BSA-A, BSA-B, BSA-C or BSA-D Switched Access.

(3) Combined Originating 800/877/888 Type Terminating Calling Feature

The Combined Originating/Terminating Calling feature is available on a per-line basis from appropriately equipped WATS Serving Offices and provides the functionalities of both the Originating Only and the 800/877/888 Type Terminating Only feature.

FACILITIES FOR INTRASTATE ACCESS

4. SWITCHED ACCESS (Cont'd)

4.2 Description of Switched Access (Cont'd)

4.2.5 End Office Services Optional Arrangements (Cont'd)

(U) Switched Access Interface (Cont'd)

(4) The following matrix details the direction, call type, service prefix and traffic types provided on each Switched Access Interface Arrangement.

Switched Access Interface Arrangements

Type	Restricted Geographic Screening	Unrestricted	Combined 800/877/888 Type Terminating	Originating- 800/877/888
Section Ref.	<u>Arrangement</u> (V)(1)(a)	<u>Arrangement</u> (V)(1)(b)	<u>Only</u> (V)(2)	<u>Terminating</u> (V)(3)
<u>Directionality</u>				
Originating Only	x	x		
Terminating Only			x	
Two-Way				x
<u>Call Type (1+)</u>				
Local B	B	B	B	B
IntraLATA/Intrast.	D	R/D	C	R/D/C
IntraLATA/Interst.	B	D	C	D/C
InterLATA/Intrast.	D	D	C	D/C
InterLATA/Interst.	B	D	C	D/C
<u>Service Prefix</u>				
0-	R	R		R
00-	D	D		D
0+	B	D		D
IDDD	B	D		D
101XXXX	B	D/B		D/B
<u>Traffic Type</u>				
411	B	B		B
911	R	R		R
976	R	R		R
700	B	D		D
500/800/877/888/900	B	D		D

D = Telephone Company DELIVERS traffic to the customer.
 R = Telephone Company RETAINS and completes traffic.
 C = Telephone Company COMPLETES traffic to the end user's premises.
 B = Telephone Company BLOCKS traffic to an announcement.

WN U-16
Zipty Fiber

Original Sheet 200

FACILITIES FOR INTRASTATE ACCESS

4. SWITCHED ACCESS (Cont'd)

4.2 Description of Switched Access (Cont'd)

4.2.5 End Office Services Optional Arrangements (Cont'd)

(U) Switched Access Interface (Cont'd)

(5) Intrastate Traffic Restrictions

An interstate Switching Interface and an intrastate Switching Interface must be ordered for the provisioning of multi-jurisdictional access.

Unless the customer subscribes to the 101XXXX blocking option offered in Section 4.2.5(U)(1)(b), all calls carried over a Special Access Line used with a Switched Access Interface for multi-jurisdictional access will be passed to the customer for completion.

The terms, conditions and rates for the interstate Special Access and Switched Access associated with this feature are in Zipty Fiber FCC Tariff 2. The terms, conditions and rates for the intrastate Switched Access are in Section 4 of this tariff.

When the customer orders multi-jurisdictional WATS Access as described above, Special Access must be ordered from Zipty Fiber FCC Tariff 2, for the facility between the end user's premises and the WATS Serving Office. If the Telephone Company's intrastate tariff provides for customer billing for these facilities, the customer will be exempt from the intrastate charge.

FACILITIES FOR INTRASTATE ACCESS

4. SWITCHED ACCESS (Cont'd)4.2 Description of Switched Access (Cont'd)4.2.5 End Office Services Optional Arrangements (Cont'd)(V) Switched Data Service(1) Switched 56

This option provides for a connection capable of up to 56 Kbps digital transmission between the customer's CDL and a suitably equipped end office. Switched Data service lines connected at those suitably equipped end offices will be accessed on a switched basis for digital transmission up to 56 Kbps. These locations are identified in the National Exchange Carrier Association, Inc., Tariff F.C.C. No. 4 Wire Center and Interconnection Information.

This option is provided only with FGD or BSA-D. A separate FGD or BSA-D trunk group must be established for the provision of Switched Data service. This trunk group requires the use of a DS1 digital interface as described in section 4.2.3(B)(6). Switched Data and Non-Switched Data traffic may not be combined on the same trunk group.

Access is made via the standard dialing pattern as specified in 4.2.1(D)(8) and 4.2.2(D)(8).

(2) Switched 64

This option provides for a connection capable of up to 64 Kbps digital transmission with clear channel capability between the customer's CDL and suitably equipped end offices. Clear channel capability allows for full bandwidth availability to the customer with no part of the channel used for control, framing or signaling.

Switched 64 requires all digital facilities including the use of DS1 digital interface as described in Section 4.2.3(B)(6) and is available only with FGD or BSA-D from end offices capable of providing SS7 Out of Band Signaling, Bipolar with Eight Zero Substitution (B8ZS) line code format and Integrated Services Digital Network (ISDN) or other Switched Data based services. These locations are identified in the National Exchange Carrier Association, Inc., Tariff F.C.C. No. 4 Wire Center and Interconnection Information. Normal FGD usage rates will apply to originating and terminating Switched 64 traffic.

Access is made via the standard dialing patterns as described in 4.2.1(D)(8) and 4.2.2(D)(8).

A separate FGD or BSA-D trunk group must be established for the provision of Switched 64 service.

Switched data and non-switched data traffic may not be combined on the same trunk group.

WN U-16
ZiPLY Fiber

Original Sheet 202

FACILITIES FOR INTRASTATE ACCESS

4. SWITCHED ACCESS (Cont'd)

4.2 Description of Switched Access (Cont'd)

4.2.5 End Office Services Optional Arrangements (Cont'd)

(W) Signaling System 7 (SS7) Out of Band Signaling

This option is provided with Common Channel Signaling System 7 (CCS7) Access Service and is only available with Switched Access FGD or BSA-D service and 800/877/888 SAC Access. CCS7 Access Service is provided pursuant to the rates, terms and conditions described in ZiPLY Fiber Tariff FCC 2. SS7 Out of Band Signaling provides common channel out of band transmission of address and supervisory SS7 protocol signaling information between the end office or access tandem switching system and the CDL. FGD or BSA-D Switched Access and 800/877/888 SAC Access service, equipped with SS7 Out of Band Signaling, are available with the following interface arrangements: DS1 Digital, DS1C Digital, DS3 Digital and DS3C Digital. SS7 Out of Band Signaling is provided at suitably equipped Telephone Company end office or access tandem switches. The technical specifications for SS7 Out of Band Signaling are described in Bellcore TTechnical Reference Publication TR-TSV-000905.

(X) Calling Party Number (CPN) Parameter

The CPN parameter, available as a nonchargeable option for originating FGD or BSA-D with SS7 Out of Band Signaling, provides for the automatic transmission of the ten digit directory number, associated with a calling station, to the customer's premises for originating calls. The ten digit number consists of the NPA plus the seven digit telephone number which may or may not be the same number as the calling station's charge number. The CPN parameter also includes a "privacy indicator" which allows the ten digit telephone number to be coded as presented or restricted for delivery to the called end user. The technical specifications for CPN are described in Bellcore TTechnical Reference Publication TR-TSV-000905.

(Y) Carrier Selection Parameter (CSP)

The CSP, available as a nonchargeable option for originating FGD or originating BSA-D with SS7 Out of Band Signaling, provides for the automatic transmission of a signaling indicator which signifies to the customer if a given call originated from a presubscribed line. If the line was presubscribed, the indicator will signify if the end user did or did not dial 101XXXX. The technical specifications for CSP are described in Bellcore TTechnical Reference Publication TR-TSV-000905.

WN U-16
Zipty Fiber

Original Sheet 203

FACILITIES FOR INTRASTATE ACCESS

4. SWITCHED ACCESS (Cont'd)

4.2 Description of Switched Access (Cont'd)

4.2.5 End Office Services Optional Arrangements (Cont'd)

(Z) Charge Number (CN) Parameter

The CN parameter, available as a nonchargeable option for originating FGD with SS7 Out of Band Signaling, is equivalent to the existing ten digit Automatic Number Identification (ANI) available with FGD with MF signaling. When BSA-D with SS7 out of Band Signaling is specified, the customer may order the CN parameter at the rates for ANI-BSE as shown in 4.6. The CN parameter provides for the automatic transmission of the ten digit billing number of the calling station and the originating line information. The technical specifications for CN are described in Bellcore TTechnical Reference Publication TR-TSV-000905.

These information digits shall only be used for billing and collection, routing, screening, and completion of the originating subscriber's call or transaction or for service directly related to the originating subscriber's call or transaction.

The information provided shall not be reused or resold without first notifying the originating telephone subscriber and obtaining affirmative consent of the subscriber for reuse or resale.

Unless the originating subscriber has given consent for the reuse or resale, any information provided shall not be used for any purpose other than:

- performing the services or transactions that are subject of the originating subscriber's call;
- ensuring network performance security, and the effectiveness of call delivery;
- compiling, using and disclosing aggregate information, and,
- complying with applicable laws.

WN U-16
ZiPLY Fiber

Original Sheet 204

FACILITIES FOR INTRASTATE ACCESS

4. SWITCHED ACCESS (Cont'd)

4.2 Description of Switched Access (Cont'd)

4.2.5 End Office Services Optional Arrangements (Cont'd)

(Z) Charge Number (CN) Parameter (Cont'd)

The above restrictions shall not prevent the subscriber to the CN Parameter from using information acquired from a CN Parameter, such as the telephone number or information derived from analysis of the characteristics of calls received through the CN Parameter, to offer a product or service that is directly related to the products or services previously purchased by a customer of the CN Parameter subscriber.

(A)(A) Tandem Switch Signaling

This option allows for the passing of the Carrier Identification Code (CIC) and the OZZ code or circuit code information needed to perform tandem switching functions. The CIC identifies the uniform access code associated with the Switched Access usage for a specific interexchange carrier. The OZZ code identifies the service class routing code of a multifrequency call that indicates the interexchange carrier's trunk group to which the traffic will be routed. The circuit code identifies the service class routing of an SS7 call that indicates the interexchange carrier's trunk group to which the traffic will be routed (e.g., 0+, 0-, 500, 900, etc). This option is only available with FGD Switched Access, 500 SAC Access, and 900 SAC Access services and can only be provided from equal access end offices. This option is not available from end offices that use alternate technologies to provide equal access capabilities, or from Telephone Company access tandems.

(A)(B) Carrier Identification Parameter (CIP)

Carrier Identification Parameter is available as an optional feature in conjunction with originating FGD with SS7 Out-of-Band Signaling. CIP provides for the transmission of the Carrier Identification Code (CIC) or the access code 101XXXX to the customer with the Initial Address Message (IAM). CIP is available with originating FGD in suitably equipped end offices and access tandems. CIP will be populated by a 4-digit CIC at the rates shown in 4.6.7.

The Telephone Company will make every effort to maintain the CIP information, equipment and facilities in a format which facilitates the customer's use of the CIP offering. Changes (i.e., technology, customer account makeup, etc.) can occur affecting such information, however, and the Telephone Company cannot guarantee that the CIP equipment and facilities will be completely capable of processing CIP data at all times. Accordingly, the Telephone Company shall not be liable for incidental, indirect, special or consequential damages (including lost revenue or profits) of any kind, resulting from inaccuracy of CIP data and/or the inability of its equipment and facilities to process CIP data.

WN U-16
ZiPLY Fiber

Original Sheet 205

FACILITIES FOR INTRASTATE ACCESS

4. SWITCHED ACCESS (Cont'd)

4.2 Description of Switched Access (Cont'd)

4.2.6 Call Restriction and Code Screening Reports

The customer, when ordering Call Denial on Line or Hunt Group, Service Class Routing or Trunk Access Limitation as described in 4.2.5, shall report the appropriate codes to be instituted in each end office switch.

4.2.7 Installation and Acceptance Testing of Switched Access

(A) The Switched Access provided under this tariff (a) will include any Telephone Company installed equipment, entrance cable or drop wiring, and wiring or cable within a building necessary to terminate the Switched Access at a point of termination reasonably situated to serve the CDL, and (b) will be installed by the Telephone Company to such a point of termination. The customer shall be responsible for providing facilities beyond the point of termination. When performing installation and acceptance testing, the Telephone Company will, on a cooperative basis, test the line or trunk beyond the customer's first point of switching (i.e., End-to-End).

(B) At no additional charge, the Telephone Company will, at the customer's request, cooperatively test, at the time of installation, loss, 3-tone slope, DC continuity, C-notched noise, C-message noise and operational signaling, when applicable. When the Interface Arrangement is established at the Telephone Company's first point of switching, and the customer requests these tests, the Telephone Company will perform the tests independently and provide the results to the customer. When the Interface Arrangement provides a four-wire voice transmission facility and the point of termination provides two-wire voice transmission (i.e., there is a four-wire to two-wire conversion at the point of termination), echo control (balance-echo return loss/equal level echo path loss) may also be tested.

Additional charges will apply as described in 6.6 when: (a) the customer requests a test not specified above, or (b) the test requested is not essential to the installation of the particular Switched Access ordered.

If acceptance tests are not started within 30 minutes after the scheduled appointment time for such tests, as negotiated between the Telephone Company and the customer, additional charges will apply, as described in 6.2, unless the delay is caused by the Telephone Company.

4.2.8 Provision of Design Layout Report

The Telephone Company will provide to the customer the makeup of the Switched Transport portion of the Switched Access provided under this tariff to enable the customer to design its overall service. This information will be reissued or updated whenever the makeup of the facilities provided to the customer are materially changed.

WN U-16
Zipty Fiber

Original Sheet 206

FACILITIES FOR INTRASTATE ACCESS

4. SWITCHED ACCESS (Cont'd)

4.2 Description of Switched Access (Cont'd)

4.2.9 Network Management

The Telephone Company will administer its network to ensure the provision of standard traffic grade of service levels to all telecommunications users of the Telephone Company's network services. The Telephone Company maintains the right to apply protective controls such as diversion of overflow traffic to informational announcements or restriction of access to congested traffic areas on any traffic carried over its network in order to assure satisfactory service levels to all customers. These controls include the right to restrict and, if necessary, deny access to and from the point of termination at the CDL.

Outage credit will apply as described in 2.4.4, in cases where all transmission paths are blocked as a result of application of protective controls, except that to the extent that these controls relate to emergency situations, no notice requirement is necessary beyond that already provided for in this tariff.

4.2.10 800/877/888 Customer Identification Function

This function utilizes 800/877/888 Data Base Query Service, as described in Zipty Fiber FCC Tariff 2, to screen all ten digits of all 800-NXX-XXXX, 877-NXX-XXXX, type or 888-NXX-XXXX type calls generated by end users to determine the customer to which the 800/877/888 call is to be routed. This function is provided with 800/877/888 SAC Access Service. This function is not available with Tandem Switch Signaling.

4.2.11 900 Customer Identification Function

This function provides for screening of the first six digits of all 900-NXX-XXXX type calls which are generated by end users for the purposes of determining the customer to which the call is to be routed. This function is provided with 900 SAC Access Service and with FGC, FGD, BSA-C and BSA-D. This function is available with Tandem Switch Signaling.

4.2.12 Design and Routing of Switched Access

The Telephone Company shall work cooperatively with the customer to design and determine the routing of Switched Access including the selection of facilities from the first point of switching to the CDL. Selection of facilities, equipment and routing of the Switched Access is based on standard engineering methods, facilities and equipment available and the Telephone Company traffic routing plans.

Issued: July 29, 2020
Issued by Zipty Fiber
By Jessica Epley, Regulatory & External Affairs Director

Effective: July 31, 2020

FACILITIES FOR INTRASTATE ACCESS

4. SWITCHED ACCESS (Cont'd)4.2 Description of Switched Access (Cont'd)4.2.13 Provision of Switched Access Performance Data

Performance data for Switched Access will be made available to the customer based on Telephone Company established intervals and availability. This data may include, but is not limited to, equipment blockage and failure results, ineffective attempt performance, transmission failures and other service-related data. Any request for data or format that is not Telephone Company standard will be handled on an Individual Case Basis with any associated cost to be borne by the customer.

4.2.14 Transmission Performance

Each Switched Access transmission path is provided with a standard transmission performance. The standard for a particular path is dependent on the Interface Arrangement and whether the Switched Access is routed direct or via an access tandem. In addition, Data Transmission Parameters may be ordered by the customer. The transmission performance parameters are described in the Technical Interface Reference Manual.

4.2.15 Design Blocking Probability

The Telephone Company will design the facilities used in the provision of Switched Access to meet the blocking probability criteria as follows:

- (A) For FGA or BSA-A no design blocking criteria apply.
- (B) For FGB, FCC, BSA-B, BSA-C and SAC Access Service the design blocking objective will be no greater than one percent (.01) between the CDL and the first point of switching. Standard traffic engineering methods as described in reference document Service Corporation Telephone Operations - Traffic Grade of Service Standards will be used by the Telephone Company to determine the number of transmission paths required to achieve this level of blocking.
- (C) For FGD or BSA-D the design blocking objective will be no greater than one percent (.01) between the CDL and the end office switch. Standard traffic engineering methods as described in reference document Service Corporation Telephone Operations - Traffic Grade of Service Standards will be used by the Telephone Company to determine the number of transmission paths required to achieve this level of blocking.

WN U-16
Zipty Fiber

Original Sheet 208

FACILITIES FOR INTRASTATE ACCESS

4. SWITCHED ACCESS (Cont'd)

4.2 Description of Switched Access (Cont'd)

4.2.15 Design Blocking Probability (Cont'd)

- (D) When FGB, FGC, FGD, BSA-B, BSA-C, BSA-D or SAC Access Service is ordered in trunks, the Telephone Company cannot guarantee these design blocking probabilities. The Telephone Company will perform routine measurement functions, except on FGA or BSA-A to assure that an adequate number of transmission paths are in service. The Telephone Company will recommend that additional capacity (BHMC or quantities of trunks) be ordered by the customer when additional paths are required to reduce the measured blocking to the designed blocking level. For the capacity ordered, the design blocking objective is assumed to have been met if the routine measurements show that the measured blocking does not exceed the threshold listed in the following tables.

WN U-16
ZiPLY Fiber

Original Sheet 209

FACILITIES FOR INTRASTATE ACCESS

4. SWITCHED ACCESS (Cont'd)

4.2 Description of Switched Access (Cont'd)

4.2.15 Design Blocking Probability (Cont'd)

(D) (Cont'd)

- (1) For FGB, FGC, BSA-B and BSA-C transmission paths carrying traffic between a CDL and the first point of switching, or FGD and BSA-D transmission paths, carrying traffic direct between a CDL and an end office, the measured blocking thresholds are as follows:

Number of Transmission Paths Per Trunk Group	Measured Blocking Thresholds in the Daily Busiest Hour for the Number of Measurements Per Trunk Group			
	15-20	11-14	7-10	5-6
	<u>Measurements</u> <u>Measurements</u>	<u>Measurements</u>	<u>Measurements</u>	
2	.070	.080	.090	.140
3	.050	.060	.070	.090
4	.050	.060	.070	.080
5-6	.040	.050	.060	.070
7 or more	.030	.035	.040	.060

- (2) For FGD or BSA-D transmission paths carrying traffic between a CDL and an end office via an access tandem, the measured blocking thresholds are as follows:

Number of Transmission Paths Per Trunk Group	Measured Blocking Thresholds in the Daily Busiest Hour for the Number of Measurements Per Trunk Group			
	15-20	11-14	7-10	5-6
	<u>Measurements</u>	<u>Measurements</u>	<u>Measurements</u>	<u>Measurements</u>
2	.045	.055	.060	.095
3	.035	.040	.045	.060
4	.035	.040	.045	.055
5-6	.025	.035	.040	.045
7 or more	.020	.025	.030	.040

WN U-16
ZiPLY Fiber

Original Sheet 210

FACILITIES FOR INTRASTATE ACCESS

4. SWITCHED ACCESS (Cont'd)

4.2 Description of Switched Access (Cont'd)

4.2.16 Special Facilities Routing

A customer may request that the facilities used to provide Switched Access be specially routed. The regulations, rates and charges for Special Facilities Routing (i.e., Avoidance, Diversity and Cable-Only) are in Section 9.

4.2.17 Information Surcharge

(A) The Information Surcharge applies to each Switched Access minute of use (measured or assumed) and shall be assessed upon all customers that use local switching facilities for the provision of intrastate telecommunications.

(B) The Information Surcharge is to recover the costs of the functions associated with the printing of the directory white pages. The surcharge is assessed to a customer based on the total number of access minutes at the rates in 4.6.4. Application of the premium and nonpremium Information Surcharge rates are in 4.5.2(H)(1).

4.2.18 800/877/888 Data Base Query Service

Information concerning 800/877/888 Data Base Query Service can be found in the Concurrence section of this tariff.

4.2.19 500 Customer Identification Function

This function provides for screening of the first six digits of all 500-NXX-XXXX type calls generated by end users to determine the customer to which the call is to be routed. This function is provided with 500 SAC Access Service and with FGC and FGD.

4.2.20 Tandem Switch Signaling

Tandem Switch Signaling, offered with FGD Switched Access, 500 SAC Access or 900 SAC Access Service with either multifrequency address signaling or SS7 Out of Band Signaling Access Service, provides the Carrier Identification Code (CIC) and the OZZ code or circuit code as described in 4.2.5(A)(E) to determine the customer and trunk group(s) where traffic will be routed.

Rate regulations applicable to Tandem Switch Signaling are found in 4.5.2.

WN U-16
ZiPLY Fiber

Original Sheet 211

FACILITIES FOR INTRASTATE ACCESS

4. SWITCHED ACCESS (Cont'd)

4.2 Description of Switched Access (Cont'd)

4.2.21 Basic Service Elements (BSE's)

The following Basic Service Elements (BSEs) are chargeable unbundled service options available only with Basic Serving Arrangements. The Telephone Company makes no guarantee that these BSE's will be available in all locations. Rate regulations and charges applicable to BSEs appear in 4.5.9 and 4.6.3.

(A) Alternate Traffic Routing - BSE

This BSE provides the capability of directing originating traffic from an end office (or appropriately equipped access tandem) via a trunk group (the "high usage" group) to a CDL until that group is fully loaded, and then delivering additional originating traffic (the "overflowing" traffic) from the same end office or access tandem to a different trunk group or groups (via one or more intermediate high usage groups) to one or more CDLs until the originating traffic is directed to a final group. The customer shall specify the last trunk CCS desired for the high usage group and each intermediate group.

When a BSA-D customer subscribes to Alternate Traffic Routing, the "final" trunk group and any intermediate trunk groups carrying additional originating overflowing traffic must terminate at the same CDL as does the "high usage" trunk group.

Alternate Traffic Routing - BSE is provided in suitably equipped end office or access tandem switches and is available with BSA-B, BSA-C, and BSA-D.

WN U-16
ZiPLY Fiber

Original Sheet 212

FACILITIES FOR INTRASTATE ACCESS

4. SWITCHED ACCESS (Cont'd)

4.2 Description of Switched Access (Cont'd)

4.2.21 Basic Service Elements (Cont'd)

(B) Automatic Number Identification (ANI) - BSE

This BSE provides the automatic transmission of a seven or ten digit number and information digit to the CDL for calls originating in the Access Area to identify the calling station. The ANI arrangement will be associated with all individual transmission paths in a trunk group when this arrangement is provided.

These information digits shall only be used for billing and collection, routing, screening, and completion of the originating subscriber's call or transaction or for service directly related to the originating subscriber's call or transaction.

The ANI provided shall not be reused or resold without first notifying the originating telephone subscriber and obtaining affirmative consent of the subscriber for reuse or resale.

Unless the originating subscriber has given consent for the reuse or resale, any information provided shall not be used for any purpose other than:

- performing the services or transactions that are subject of the originating subscriber's call;
- ensuring network performance security, and the effectiveness of call delivery;
- compiling, using and disclosing aggregate information; and,
- complying with applicable laws.

WN U-16
Zipty Fiber

Original Sheet 213

FACILITIES FOR INTRASTATE ACCESS

4. SWITCHED ACCESS (Cont'd)

4.2 Description of Switched Access (Cont'd)

4.2.21 Basic Service Elements (Cont'd)

(B) Automatic Number Identification (ANI) - BSE (Cont'd)

The above restrictions shall not prevent the subscriber to the ANI Arrangement from using information acquired from an ANI Arrangement, such as the telephone number or information derived from analysis of the characteristics of calls received through the ANI Arrangement, to offer a product or service that is directly related to the products or services previously purchased by a customer of the ANI Arrangement subscriber.

The seven digit ANI telephone number is available with BSA-B and BSA-C. It will be transmitted on all calls except those identified as a multiparty line or ANI failure. The ten digit ANI telephone number is only available with BSA-D. When BSA-D with SS7 Out of Band Signaling is specified, the customer may order an ANI equivalent by ordering the Charge Number Parameter as described in 4.2.5(Z) at the rates for ANI-BSE as shown in 4.6. The ten digit ANI telephone number consists of the Numbering Plan Area (NPA) plus the seven digit ANI telephone number. The ten digit ANI telephone number will be transmitted on all calls except those identified as a multiparty line or ANI failure in which case only the NPA will be transmitted (in addition to the information digit described below). The ANI telephone number is the listed telephone number of the end user that originates the call.

WN U-16
Zipty Fiber

Original Sheet 214

FACILITIES FOR INTRASTATE ACCESS

4. SWITCHED ACCESS (Cont'd)

4.2 Description of Switched Access (Cont'd)

4.2.21 Basic Service Elements (Cont'd)

(B) Automatic Number Identification (ANI) - BSE (Cont'd)

With BSA-C, ANI is provided from end offices at which the Telephone Company recording for end user billing is not provided, or where it is not required, as with 800/877/888 Service. It is not provided from end offices for which the Telephone Company needs to forward ANI to its recording equipment.

Where ANI cannot be provided (e.g., on calls from 2, and in some instances 4, party service) information digits will be provided to the customer. The information digits are used in the following situations:

- (1) Telephone number is the station billing number - no special treatment is required.
- (2) Multiparty line telephone number is a 2 or 4 party line and cannot be identified - number must be obtained via an operator or in some other manner.
- (3) ANI failure has occurred in the end office switch which prevents identification of calling telephone number - number must be obtained by operator or in some other manner.

WN U-16
Zipty Fiber

Original Sheet 215

FACILITIES FOR INTRASTATE ACCESS

4. SWITCHED ACCESS (Cont'd)

4.2 Description of Switched Access (Cont'd)

4.2.21 Basic Service Elements (Cont'd)

(B) Automatic Number Identification (ANI) - BSE (Cont'd)

(4) The configuration of the line requires special screening or handling by the customer, or

(5) Call is an Automatic Identified Outward Dialed (AIOD) call from end user terminal equipment.

These ANI information digits are available with BSA-B, BSA-C, and BSA-D only. In addition, the following information digits are available with BSA-D only:

(a) InterLATA Area restricted - telephone number is identified line.

(b) InterLATA Area restricted - line requires special screening or handling by the customer.

These information digits will be transmitted as agreed to by the customer and the Telephone Company.

(C) User Transfer

A feature which provides the ability to temporarily hold an established call, originate another call to a third party, and then redirect the first call to the third party. When a call has been transferred, the original line/trunk is cleared to place or receive another call.

FACILITIES FOR INTRASTATE ACCESS

4. SWITCHED ACCESS (Cont'd)

4.2 Description of Switched Access (Cont'd)

4.2.21 Basic Service Elements (Cont'd)

(D) Hunt Group Arrangement - BSE

This BSE, available only with BSA-A, provides the ability to sequentially access one of two or more line side connections in the originating direction, when the access code of the line group is dialed. This BSE contemplates one access code (i.e., telephone number) per arrangement. This BSE also provides the ability to sequentially access one of two or more lines in the terminating direction, when the hunting number of the line group is forwarded from the customer to the Telephone Company.

(E) Queuing - BSE

This BSE is available only with BSA-A in conjunction with the Uniform Call Distribution (UCD) BSE and may only be provided in Telephone Company electronic end offices.

When all terminals in a UCD Arrangement are busy, queuing allows for an incoming call to be placed in queue to await an available terminal in the UCD arrangement. When a call is placed in queue, audible ringing is returned to the customer and no further indication is sent until a terminal completes the call. The call that has been in queue the longest will be the first call handled when a terminal becomes available. The maximum number of calls that can be placed in queue is dependent upon the total number of lines in the multiline hunt group. If the incoming call cannot be placed in queue, the calling party will receive a busy tone.

(F) Uniform Call Distribution - BSE

This BSE provides a type of multiline hunting arrangement which evenly distributes calls among the available lines in a hunt group. Where available, this arrangement is provided with originating use for BSA-A and terminating use for Special Access Lines.

FACILITIES FOR INTRASTATE ACCESS

4. SWITCHED ACCESS (Cont'd)4.2 Description of Switched Access (Cont'd)4.2.21 Basic Service Elements (Cont'd)(G) Simplified Message Desk Interface

This option provides call-related information for calls utilizing a BSE hunt group arrangement. SMDI provides the capability for delivering the called number, the calling number, and a call forwarding indicator (i.e., call forwarding busy, call forwarding don't answer, or direct call). This information is transmitted to the CDL utilizing a DNAL (Section 4.2.2). In addition, where customer equipment exists, SMDI will allow a customer to activate a message waiting indicator to the called number. The message waiting indicator includes Message Waiting Indication - Audible or Message Waiting Indication - Audible Ring Burst.

The customer shall provide the appropriate Customer Premises Equipment (CPE) to store, display or print the transmitted call status information as well as equipment to activate or deactivate the message waiting indicator. The Telephone Company assumes no liability and will be held harmless for any incompatibility of their CPE to perform satisfactorily with this feature. This BSE, available with BSA-A, is provided from suitably equipped end offices. The customer is responsible for providing a modem at the CDL which interfaces with the Telephone Company equipment at 1200 baud ASCII.

(H) Caller Identification - Number - BSE

This BSE provides the customer with the calling party's directory number at the time the call is received. The calling number is transmitted to the customer during the first silent interval of the ringing cycle. The number is displayed on customer-provided equipment.

Where available, this arrangement is provided as a nonchargeable option with originating BSA-D.

(I) Remote Call Forwarding - BSE

Remote Call Forwarding (RCF) is a service that utilizes a seven digit Directory Number (DN) to automatically forward all incoming calls to another DN. The forwarded to number can be in the same central office switch or in another central office switch.

The remote call forwarding directory number is not directly associated with an access connection arrangement, but rather is a software translation programmed within the central office switch. All calls dialed to that directory number will forward to another number automatically. The subscriber to this capability does not have a station set for termination of calls made to their remote call forwarding number. Where available, this arrangement is provided with BSA-A.

WN U-16
Zipty Fiber

Original Sheet 218

FACILITIES FOR INTRASTATE ACCESS

4. SWITCHED ACCESS (Cont'd)

4.2 Description of Switched Access (Cont'd)

4.2.21 Basic Service Elements (Cont'd)

(J) Direct Inward Dialing (DID) - BSE

This BSE provides a two or four wire DID trunk side termination with line treatment at the first point of switching that permits the Dial Tone Central Office Switch to deliver all or part of the called number to the customer premises at the time the call is established. Multifrequency (MF), Dual Tone Multifrequency (DTMF) or Dial Pulse address signaling is used by the Telephone Company to deliver only the called telephone number to the customer premises. No other address signaling will be delivered to the customer premises. The type of signaling utilized depends on the Dial Tone Office switching equipment available. If additional address signaling is required by the customer, it must be provided by the customer's end user using inband tone address signals which will not be regenerated by the Telephone Company and will be subject to the ordinary transmission capabilities of the Switched Transport provided.

This BSE is only available with new BSA-A arrangements and only in the originating direction. The customer must order a DID Termination and the first group of 20 DID numbers to be associated with the DID Termination in addition to BSA-A service. Additional groups of 20 DID telephone numbers are available. The DID optional feature is only available as a stand alone BSE or optional feature, no other BSEs or optional features can be used with it.

(K) Billed Number Screening - BSE

This BSE prevents the billing of incoming collect and third number billed calls to a customer's telephone account.

Where available, this arrangement is provided with BSA-A.

(L) Digital Channel Service - BSE

This BSE provides a digital common line connection between the CDL and the local serving wire center. The digital transmission rate available is either DS1 (1.544 Mbps) or DS3 (44.736 Mbps).

Digital Channel Service will be used by the customer to aggregate the customer's telecommunication services onto a digital local loop.

This arrangement is provided on an Individual Case Basis (ICB) with BSA-D.

WN U-16
Zipty Fiber

Original Sheet 219

FACILITIES FOR INTRASTATE ACCESS

4. SWITCHED ACCESS (Cont'd)

4.2 Description of Switched Access (Cont'd)

4.2.22 IntraLATA Equal Access Recovery Charge

The IntraLATA Equal Access Recovery Charge is designed to recover those costs that the Telephone Company incurs solely in connection with intraLATA equal access. The charge applies to each Originating Switched Access minute of use and shall be assessed upon all customers that use local exchange switching facilities for the provision of intrastate telecommunications. The IntraLATA Equal Access Recovery Charge is found in 4.6.5.

(D)
|
(D)

FACILITIES FOR INTRASTATE ACCESS

4. SWITCHED ACCESS (Cont'd)4.3 Obligations of the Customer4.3.1 On and Off-Hook Supervision

The customer facilities shall provide the necessary on and off-hook supervision.

4.3.2 ASR Requirements

The customer shall order all Switched Access in Section 3, and 4.3.2 and 4.3.3.

ASRs for Entrance Facilities and Direct-Trunked Transport must specify the customer designated location, type of service (e.g., Voice Grade, DS1 or DS3), the channel interface, and any optional arrangements desired. In addition, ASRs for Direct-Trunked Transport must specify any Hubs involved and the end office, when direct routing to an end office is desired, or the Telephone Company access tandem if direct routing to a Telephone Company access tandem switch for purposes of obtaining Tandem-Switched Transport is desired.

ASRs for Direct-Trunked Transport must also specify the Feature Group or BSA, number of lines or trunks at the end office or Telephone Company access tandem, major traffic types and directionality. Ordered quantities shall be specified by originating and terminating direction and by traffic type (e.g., MTS/MTS-type or WATS/WATS-type). Where the customer desires to segregate its originating traffic into separate trunk groups by type of traffic, the customer must specify the ordered quantities by trunk group and by traffic type. For example, if a customer desires a separate trunk group to carry its 500, 800, 877, 888 or 900 traffic, the order must specify the trunks or BHMCs associated with 500, 800, 877, 888 or 900 traffic for that trunk group.

Customers may order Tandem-Switched Transport by specifying the number of trunks required between the CDL and access tandem switch or BHMCs between the CDL and the end office. The customer shall provide, when it orders BHMC, its projected intrastate BHMC between the CDL and each end office in the Access Area by traffic type. The customer shall provide, when it orders lines or trunks, its projected intrastate traffic distribution by percent for each end office in the Access Area by traffic type. If the customer fails to provide its traffic distribution, the Telephone Company will use appropriate Telephone Company traffic studies to project distribution by end office.

When FGA or BSA-A is ordered the customer shall specify whether or not the terminating traffic is to be restricted to the Access Area as described in 4.2.1, 4.2.2 and 4.2.5(C), (D) or (E) or extended beyond the Access Area (i.e., local calling area). If the customer wishes to extend the traffic beyond the FGA Access Area, the rates as described in 4.5.2(H)(3), will apply. If the customer wishes to restrict the traffic, the rates as described in 4.5.2(A)(3)(i) may apply, depending upon the optional arrangement selected.

When the Alternative Traffic Routing optional arrangement is provided, Percent Traffic Routed (PTR) values must be provided on the ASR as described in 4.5.2(H)(2)(h).

FACILITIES FOR INTRASTATE ACCESS

4. SWITCHED ACCESS (Cont'd)4.3 Obligations of the Customer (Cont'd)4.3.2 ASR Requirements (Cont'd)

When a customer orders Switched Access for mixed interstate and intrastate usage, the customer shall provide an estimate of the total usage which will be intrastate by traffic type. The customer allocated percentages will be used as a basis of the jurisdictional determination for billing purposes of all charges until a more accurate determination can be provided as described in 4.3.3 and 4.5.2(D).

4.3.3 Jurisdictional Report Requirements(A) Jurisdictional Reports(1) Percent Interstate Usage (PIU)

- (a) When the Telephone Company receives sufficient call detail to permit it to determine the jurisdiction of some or all originating and terminating access minutes of use, the Telephone Company will use that call detail to render bills for those minutes of use and will not use customer-reported Percent Interstate Usage (PIU) factors to determine the jurisdiction of those minutes of use.

The Telephone Company will apply the PIU factor, either provided by the customer or as set forth in section (1)(b) or (A)(3), only to minutes of use for which the Telephone Company does not have sufficient call detail to determine jurisdiction. The customer reported PIU factor will be used until the customer provides an updated PIU factor as set forth in (A)(3) following. No prorating or back billing will be done based on the updated report.

There may be some portion of terminating minutes where it is not possible to know, and therefore to send, the needed originating number information. A "floor" of 7.00 percent (%) will be set for terminating minutes lacking originating number, for all switched access customers.

- (1) When the percentage of terminating traffic without sufficient call detail to determine jurisdiction does not exceed the sum of the floor plus a 2.00 percent (%) grace threshold or 9.00 percent (%), the Telephone Company will apply the PIU factor, either provided by the customer or as set forth in section (1)(b).
-

WN U-16
Zipty Fiber

Original Sheet 222

FACILITIES FOR INTRASTATE ACCESS

4. SWITCHED ACCESS (Cont'd)

4.3 Obligations of the Customer (Cont'd)

4.3.3 Jurisdictional Report Requirements (Cont'd)

(A) Jurisdictional Reports (Cont'd)

(1) Percent Interstate Usage (PIU) (Cont'd)

(a) (Cont'd)

(2) When the percentage is greater than 9.00 percent (%), the Telephone Company will assess rates from this tariff on all minutes exceeding the floor. For example, if 30.00 percent (%) of a customer's terminating minutes sent to the Telephone Company do not contain sufficient originating information to allow the Telephone Company to determine the originating location, then the Company would apply the provisions of this tariff to those minutes exceeding the "floor", or 23.00 percent (%) in this example.

In the event that the Telephone Company applies rates to terminating calls without originating number information as provided in this tariff, customers will have the opportunity to request backup documentation of the Telephone Company's basis for such application, and further request that the Telephone Company change the application of the intrastate access rate upon a showing of why the intrastate rate should not be applied.

(b) When the customer initially orders Switched Access Service(s) the customer will state in the Access Service Request order a PIU factor. This factor will be used by the Telephone Company as the customer-provided PIU factor until the customer provides updated PIU factors as required in (A)(3) following.

WN U-16
Zipty Fiber

Original Sheet 223

FACILITIES FOR INTRASTATE ACCESS

4. SWITCHED ACCESS (Cont'd)

4.3 Obligations of the Customer (Cont'd)

4.3.3 Jurisdictional Report Requirements (Cont'd)

(A) Jurisdictional Reports (Cont'd)

(1) Percent Interstate Usage (PIU) (Cont'd)

(b) (Cont'd)

For each service listed below, the customer may provide separate PIU factors, in accordance with (A)(1)(a) and (c).

- Feature Group A (FGA) Switched Access Service ^{1, 2}
- Feature Group B (FGB) Switched Access Service ^{1, 2}
- Feature Group C (FGC) Switched Access Service ^{1, 2}
- Feature Group D (FGD) Switched Access Service ^{1, 2}
- Basic Serving Arrangement A (BSA-A) ^{1, 2, 3}
- Basic Serving Arrangement B (BSA-B) ^{1, 2, 3}
- Basic Serving Arrangement C (BSA-C) ^{1, 2, 3}
- Basic Serving Arrangement D (BSA-D) ^{1, 2, 3}
- 500 Access Services ^{1, 2}
- 700 Access Services ^{1, 2}
- Toll Free Services ^{1, 2, 4}
- 900 Access Services ^{1, 2}

When a customer submits an order for Switched Access services, the customer must state the PIU factor on a statewide, LATA, or billing account number (BAN) level.

When the customer provides PIU factors, the Telephone Company will subtract the customer-provided PIU factors from 100 and the difference is the percent intrastate usage. The sum of the interstate and intrastate percentages will equal 100 percent. The customer may only provide a PIU factor that is a whole number (a number from 0 to 100).

- ¹ The PIU will be applied to all associated elements and services, e.g. Carrier Common Line, End Office Switching, Information Surcharge, Interconnection Charge, Line Extension Rate Additive, Dedicated Trunk Port, Access Tandem Dedicated Trunk Port, Shared Trunk Port and, if applicable, Tandem Switched Transport and Tandem Switching minutes of use.
 - ² The PIU for Switched Access services must be provided by the customer of record when used with Tandem Switch Signaling.
 - ³ When determining the jurisdiction of Switched Access traffic provided via a BSA or Basic Service Element (BSE) and the intrastate equivalent of the BSA or BSE is only available on a bundled feature group basis, intrastate usage will be prorated to the bundled intrastate feature group equivalent of the BSA.
 - ⁴ "Toll Free" service includes any access service, which utilizes the following NPAs: 800, 888, 877, 866, 855, 844, 833, and 822 as they become available to the industry.
-

WN U-16
Zipty Fiber

Original Sheet 224

FACILITIES FOR INTRASTATE ACCESS

4. SWITCHED ACCESS (Cont'd)

4.3 Obligations of the Customer (Cont'd)

4.3.3 Jurisdictional Report Requirements

(A) Jurisdictional Reports

(1) Percent Interstate Usage (PIU)

- (c) For purposes of developing the projected interstate percentage for Feature Group C (or BSA-C) and Feature Group D (or BSA-D), the customer shall consider every call that originates from a calling party in one state and terminates to a called party in a different state to be interstate communications. The customer shall consider every call that terminates to a called party within the same state as the state where the calling party is located, to be intrastate communications. The manner in which a call is routed through the telecommunications network does not affect the jurisdiction of a call; i.e., a call between two points within the same state is an intrastate call even if it is routed through another state.

For purposes of developing the projected interstate percentage for Feature Group A (or BSA-A) and Feature Group B (or BSA-B), pursuant to Federal Communications Commission order FCC 85-145 adopted April 16, 1985, interstate usage is to be developed as though every call that enters a customer network at a point within the same state as that in which the called station is situated is an intrastate communication; and every call that enters a customer's network at a point in a state other than that where the called station is situated is an interstate communication.

WN U-16
ZiPLY Fiber

Original Sheet 225

FACILITIES FOR INTRASTATE ACCESS

4. SWITCHED ACCESS (Cont'd)

4.3 Obligations of the Customer (Cont'd)

4.3.3 Jurisdictional Report Requirements (Cont'd)

(A) Jurisdictional Reports (Cont'd)

(2) Entrance Facilities and Direct-Trunked Transport Facilities

The Telephone Company will develop a PIU factor to apply to Entrance Facility and Direct-Trunked Transport rate elements when sufficient call detail exists. The Company will apply the PIU factor provided by the customer as set forth in (A)(1)(b) or (A)(3) only when the Company does not have sufficient data to develop a PIU factor.

A customer may provide a separate PIU factor for each rate element (Entrance Facility, Direct-Trunked Transport) at a Billing Account Number or higher reporting level reflecting the originating and terminating traffic of all Switched Access services that use such facilities. When a customer orders the same type of Entrance Facility and Direct-Trunked Transport, i.e., DSO, DS1 or DS3, from the CDL to the first point of switching or Telephone Company hub, the customer may submit one PIU factor to be applied to both the Entrance Facility and the Direct Trunked Transport. A consolidated PIU factor for all Entrance Facility and Direct-Trunked Transport elements may be provided at the option of the customer if such PIU is representative of the actual interstate use of the service.

(3) Jurisdictional Report Updates

The customer may update the interstate and intrastate jurisdictional reports on a quarterly basis. The reports will be based on the prior three months call detail records and will be due within fifteen days after the end of the quarter beginning with the completion of the first full quarter of service. In the event that the Telephone Company does not have sufficient data to rely on actual call detail or to develop a PIU factor, these factors will be applied to activity dated on or after the first day of the next calendar month, which begins at least 15 business days after the day on which the revised report or letter is received.

If the revised factors represent what the Telephone Company considers to be a substantial deviation (a deviation of 5 percentage points or more for the preceding twelve calendar months is a substantial deviation) from the customer's previously reported factors and cannot be attributed to seasonal changes or other identifiable reasons, the Telephone Company will request a Jurisdictional Report Verification of the factors as set forth in (C) following.

WN U-16
ZiPLY Fiber

Original Sheet 226

FACILITIES FOR INTRASTATE ACCESS

4. SWITCHED ACCESS (Cont'd)

4.3 Obligations of the Customer (Cont'd)

4.3.3 Jurisdictional Report Requirements (Cont'd)

(A) Jurisdictional Reports (Cont'd)

(3) Jurisdictional Report Updates (Cont'd)

When the Telephone Company does not have sufficient data to rely on actual call detail or to develop a PIU factor, the revised report or letter will serve as the basis for the next three months' billing and will be effective on the bill date for that service. In the event the customer fails to provide a report for one or more quarters, the Telephone Company will use the most recently provided quarterly report for subsequent bills until the customer provides an update report.

For those cases in which a quarterly report or letter has never been received from the customer, the Telephone Company will assume the customer-provided PIU factors to be the same as provided in the order for service.

A customer may file jurisdictional reports aggregating usage at a statewide, LATA or BAN level.

(B) Maintenance of Customer Records

The customer shall retain, for a minimum of twelve months, call detail records that substantiate the interstate percent provided to the Telephone Company as set forth in (A) preceding for switched access service. Such records shall consist of (1) and (2) following, if applicable:

- (1) All call detail records such as work papers and/or backup documentation including paper, magnetic tapes or any other form of records for billed customer traffic, call information including call originating and terminating address (i.e., calling, called number), the call duration, all originating and terminating trunk groups or switched access lines over which the call is routed, and the point at which the call enters the customer's network and;
 - (2) If the customer has a mechanized system in place that calculates the PIU factor, then a description of that system and the methodology used to calculate the PIU factor must be furnished and any other pertinent information (such as but not limited to flowcharts, source code, etc.) relating to such system must also be made available.
-

Issued: July 29, 2020
Issued by ZiPLY Fiber
By Jessica Epley, Regulatory & External Affairs Director

Effective: July 31, 2020

FACILITIES FOR INTRASTATE ACCESS

4. SWITCHED ACCESS (Cont'd)4.3 Obligations of the Customer (Cont'd)4.3.3 Jurisdictional Report Requirements (Cont'd)(C) Jurisdictional Reports Verification

The Telephone Company may by written request ask the customer to verify their jurisdictional reports. The customer shall keep records of call detail from which the percentage of interstate and intrastate use can be ascertained. The Telephone Company will request the customer to provide the records of call detail and other information, as specified in (B) preceding, that the customer used to determine the percentage of interstate and intrastate use where the customer has provided such factors. No more than one verification request will be made per year.

- (1) If the PIU factors filed by the customer cannot be validated by the data provided, and the data provided by the customer is sufficient to calculate a PIU factor different than the customer's reported PIU factor, the Telephone Company will use these records to:
 - (a) Revise the customer's PIU factor.
 - (b) Calculate the interstate and intrastate access charges that should have been billed to the customer for the prior period specified in (B) preceding that the inaccurate PIUs had been used and debit or credit the customer for the difference between the charges that should have been billed with the default PIU and the charges that were billed.
 - (2) The customer shall supply the data to the Telephone Company within 30 days of the Telephone Company request. The Telephone Company will request data for the four prior quarters unless a shorter period is requested by the customer and agreed to by the Telephone Company.
 - (3) If the customer fails to supply data, as specified in (B) preceding within 45 calendar days of the Telephone Company's request, sufficient for the Telephone Company to substantiate or determine PIU factors, then:
 - (a) The Telephone Company will apply a default PIU factor of 50% to the traffic for which the Telephone Company does not have sufficient call detail to determine the jurisdiction of the traffic ("unknown jurisdiction" usage) (i.e., 50% of the unknown jurisdiction usage will be billed under the interstate jurisdiction and 50% of the unknown jurisdiction usage will be billed under the intrastate jurisdiction) in lieu of the PIU factors last submitted by the customer.
-

WN U-16
ZiPLY Fiber

Original Sheet 228

FACILITIES FOR INTRASTATE ACCESS

4. SWITCHED ACCESS (Cont'd)

4.3 Obligations of the Customer (Cont'd)

4.3.3 Jurisdictional Report Requirements (Cont'd)

(C) Jurisdictional Reports Verification (Cont'd)

(3) (Cont'd)

- (b) The Telephone Company will apply the default PIU factor to all future switched access minutes of use with unknown jurisdiction beginning with the first bill date following the 45 calendar day period during which the customer was to submit the records of call detail requested by the Telephone Company. The application of the default PIU factor will continue until the customer provides the Telephone Company with records of call detail that are sufficient for the Telephone Company to substantiate the customer-provided PIU factors.

(D) Contested Jurisdictional Reports

If, after reviewing the data provided by the customer, the Telephone Company determines the customer-provided PIUs are inaccurate, the Telephone Company will report the results of the analysis to the customer by Certified U.S. Mail (return receipt requested). The Telephone Company will request that the customer provide updated PIU factors consistent with those contained in the Telephone Company's report.

FACILITIES FOR INTRASTATE ACCESS

4. SWITCHED ACCESS (Cont'd)4.3 Obligations of the Customer (Cont'd)4.3.3 Jurisdictional Report Requirements (Cont'd)(D) Contested Jurisdictional Reports (Cont'd)

If the Telephone Company applies the revised or default PIU factor to the customer's account as provided in (C) preceding in lieu of the customer-provided PIU factor, the customer may contest application of the default PIU by providing written notification, by Certified U.S. Mail (return receipt requested), to the Telephone Company within thirty (30) calendar days from the date that the Telephone Company provides notice to the customer of its decision to apply the revised or default PIU. The customer may request that the dispute be resolved by a neutral arbitrator mutually agreed upon by the Telephone Company and the customer. Arbitration is an option provided in addition to the customer's existing right to file a complaint or legal action in a court of law or at the Washington Utilities and Transportation Commission for resolution of the dispute. The arbitration hearing will be conducted in Washington within the Telephone Company's operating territory where the customer maintains its principal place of business or at a location within the Telephone Company's operating territory that is mutually agreed upon by both parties. The arbitration procedures shall be governed by the law (both statutory and case) of Washington, including, but not limited to, the Uniform Arbitration Act, as adopted in Washington. The arbitrator shall determine the customer's PIU for each category of traffic based on the standards in (A) preceding.

Prior to the arbitration hearing, each party shall notify the arbitrator of the PIU factor(s) which that party believes to be correct. The arbitrator, in deciding, may adopt the PIU percentage of either party or may adopt a PIU different from those proposed by the parties. If the arbitrator adopts a PIU proposed by one of the parties, the other party (whose PIU was not adopted) shall pay all costs of the arbitration. If the arbitrator adopts a PIU percentage higher than either of the PIU proposed by the parties, then the party proposing the lower PIU shall pay all costs of the arbitration. If the arbitrator adopts a PIU lower than either of the PIU proposed by the parties, then the party proposing the higher PIU shall pay all costs of the arbitration. If the arbitrator adopts a PIU which falls between the two percentages adopted by the parties, then the parties shall each pay one-half of the arbitration costs.

WN U-16
Zipty Fiber

Original Sheet 230

FACILITIES FOR INTRASTATE ACCESS

4. SWITCHED ACCESS (Cont'd)

4.3 Obligations of the Customer (Cont'd)

4.3.3 Jurisdictional Report Requirements (Cont'd)

(D) Contested Jurisdictional Reports (Cont'd)

The PIU factor(s) for each category of traffic determined by the arbitrator will be applied by the Telephone Company to all future access minutes of use with unknown jurisdiction from that customer in Washington until the customer provides the Telephone Company with records of call detail or other data that are sufficient for the Telephone Company to substantiate the customer-provided PIU factors.

Absent the customer's written notification, within the timeframe noted above, the customer must comply with the provisions set forth in (B) and (C) preceding. If the customer fails to comply with these provisions, the customer will be in violation of this Tariff and the Telephone Company may refuse additional applications for service and/or refuse to complete any and all pending orders for service or may discontinue the provision of the services to the customer as specified in 2.1.8 preceding.

The Telephone Company retains the right to pursue any and all other legal remedies, whether in addition to, or in lieu of, the above procedures, to recover any under-billed switched access charges associated with incorrect customer-provided PIU factors under the applicable interstate or intrastate tariffs.

WN U-16
Zipty Fiber

Original Sheet 231

FACILITIES FOR INTRASTATE ACCESS

4. SWITCHED ACCESS (Cont'd)

4.4 Payment Arrangements and Credit Allowances

4.4.1 Cancellation of Applications

A customer may cancel an application for Switched Access in accordance with the regulations and charges in Section 3.

4.4.2 Credit Allowances

Allowances for interruptions are as in 2.4.4.

4.5 Rate and Charge Regulations

4.5.1 Rate Elements

For the purposes of determining the rates and charges for Switched Access, including SAC Access Service, the following rate elements may apply:

- Shared Trunk Port
- Dedicated Trunk Port
- Entrance Facility
- Direct-Trunked Transport
- Tandem-Switched Transport
- Interconnection Charge
- Multiplexing
- End Office Switching
- Information Surcharge
- IntraLATA Equal Access Recovery Charge¹

FGB, FGC, FGD, BSA-B, BSA-C, BSA-D and SAC Access Service are also subject to the Network Blocking charges as in 4.5.2(C).

¹ Rate commences on September 10, 1996

FACILITIES FOR INTRASTATE ACCESS

4. SWITCHED ACCESS (Cont'd)

4.5 Rate and Charge Regulations (Cont'd)

4.5.1 Rate Elements (Cont'd)

4.5.2 Rate Regulations

This section contains the specific regulations governing the rates and charges that apply for Switched Access including SAC Access Service.

(A) Types of Rates and Charges

The following types of rates and charges apply to Switched Access.

(1) Usage Rates

Usage rates are applied on a per Access Minute basis either as premium or nonpremium as described in 4.5.2(H)(1).

Tandem-Switched Transport - Termination, Tandem Switching, Interconnection, End Office Switching and Information Surcharge rate elements are usage rated.

The Tandem-Switched Transport - Facility rate element is both usage and distance-sensitive.

(2) Flat Rated

Flat rates apply, on a per month basis, regardless of the amount of usage. Flat rates may be either distance-sensitive or non-distance sensitive.

Direct-Trunked Transport is flat rated and, with the exception of Voiceband Transport, is both distance and nondistance-sensitive. Voiceband Transport is distance-sensitive only.

Entrance Facility rate elements are flat rated and nondistance-sensitive.

Multiplexing charges are flat rated elements.

FACILITIES FOR INTRASTATE ACCESS

4. SWITCHED ACCESS (Cont'd)4.5 Rate and Charge Regulations (Cont'd)4.5.2 Rate Regulations (Cont'd)(A) Types of Rates and Charges (Cont'd)(3) Nonrecurring Charges

Nonrecurring charges are one-time charges that apply for specific work activities associated with providing Switched Access Service or changing an existing Switched Access arrangement, Feature Group or Basic Serving Arrangement.

(a) Service Installation Charges

The Service Installation Charge applies to customer requests for installation of Switched Access Entrance Facilities from the CDL to the serving wire center. The charge applies on a per Entrance Facility basis and is dependent upon the type of Entrance Facility ordered (i.e., Voiceband, DS1 or DS3).

(b) Installation of Voiceband Entrance Facilities

The Service Installation Charge associated with the installation of Voiceband Entrance Facilities is specified in 4.6.2(G).

(c) Installation of Multiplexing Arrangements

A Nonrecurring Charge applies for the installation of multiplexing arrangements available with Switched Access Service. This charge applies per multiplexing arrangement ordered and is dependent upon the type of multiplexing performed. (DS1 to Voice or DS3 to DS1). This charge also applies whether the multiplexing arrangement is installed coincident with the initial installation or at anytime subsequent to the installation of service.

(d) Installation of DS1 and DS3 Entrance Facilities(1) DS1 Standard Arrangements

For DS1 Entrance Facilities, a separate nonrecurring charge applies for the first DS1 Entrance Facility ordered and each additional DS1 Entrance Facility between the same CDL and serving wire center. The "First System" charge is assessed per entrance facility for the first DS1 ordered. When the same customer requests additional DS1 service on the same ASR, to be installed at the same time between the same CDL and serving wire center, the "Additional System" charge will apply.

WN U-16
ZiPLY Fiber

Original Sheet 234

FACILITIES FOR INTRASTATE ACCESS

4. SWITCHED ACCESS (Cont'd)

4.5 Rate and Charge Regulations (Cont'd)

4.5.2 Rate Regulations (Cont'd)

(A) Types of Rates and Charges (Cont'd)

(3) Nonrecurring Charges (Cont'd)

(d) Installation of DS1 and DS3 Entrance Facilities (Cont'd)

(2) DS1 Optional Payment Plan (OPP) Arrangements

Customers subscribing to the DS1 OPP arrangements at rates in 4.6.2(K) will not be assessed a nonrecurring charge (NRC) for initial installation of a "First System" DS1 Entrance Facility. For each "Additional System" DS1 Entrance Facility, the NRC in 4.6.2(H) will apply. In addition, under a DS1 OPP, the "Additional System" DS1 Entrance Facility may be ordered as described in 4.5.5 at any time by the same customer between the same CDL and its serving wire center or hub wire center as the "First System" DS1 Entrance Facility.

The regulations in Section 4.5.2(A)(3)(g) will apply to existing DS1 OPP customers when required for changes and other service rearrangements.

(3) DS3 Arrangements

For Individual and Unlimited System DS3 Entrance Facilities, the charge for the installation will apply at the rates in 4.6.2(I) and 4.6.2(M). These charges will apply for each DS3 Entrance Facility ordered on a month-to-month basis or subscribed to on a term commitment plan.

WN U-16
Zipty Fiber

Original Sheet 235

FACILITIES FOR INTRASTATE ACCESS

4. SWITCHED ACCESS (Cont'd)

4.5 Rate and Charge Regulations (Cont'd)

4.5.2 Rate Regulations (Cont'd)

(A) Types of Rates and Charges (Cont'd)

(3) Nonrecurring Charges (Cont'd)

(e) Switched Access Installation Charge Waiver

All nonrecurring charges (NRCs) for service connection are waived when a customer converts trunks from tandem-switched to direct-trunked or from direct-trunked to tandem-switched. NRCs are also waived if a customer orders the discontinuance of overprovisioned trunks, or the conversion of existing Switched Transport circuits from a lower capacity service to a higher capacity service or from a higher capacity service to a lower capacity service.

(f) Switched Access Ordering Charges

This charge, applied on a per ASR basis, is associated with the work performed by the Telephone Company in connection with the receiving, recording and processing of service requests. The Switched Access Ordering Charge applies to all requests to establish Entrance Facilities, Direct-Trunked Transport Facilities, and Tandem-Switched Transport Facilities. Where Entrance Facilities and Direct-Trunked and/or Tandem-Switched Transport are ordered on a single ASR, only one Switched Access Ordering Charge applies. This charge is in addition to any Service Installation Charge for Entrance Facility installations.

Switched Access Ordering Charge will apply for a change in FGD or BSA-D switched access and 800/877/888 SAC Access signaling from multifrequency address signaling to SS7 Out of Band Signaling except as specified above.

Switched Access Ordering Charge will not apply if Calling Party Number (CPN) Parameter, Carrier Selection Parameter (CSP), and/or Charge Number (CN) Parameter are ordered at the same time as SS7 Out of Band Signaling is ordered with FGD. The Switched Access Ordering Charge will apply if these optional features are ordered subsequent to the provision of SS7 Out of Band Signaling.

WN U-16
Zipty Fiber

Original Sheet 236

FACILITIES FOR INTRASTATE ACCESS

4. SWITCHED ACCESS (Cont'd)

4.5 Rate and Charge Regulations (Cont'd)

4.5.2 Rate Regulations (Cont'd)

(A) Types of Rates and Charges (Cont'd)

(3) Nonrecurring Charges (Cont'd)

(f) Switched Access Ordering Charges (Cont'd)

Switched Access Ordering Charge applies to a customer request to change an end user WATS Access line (i.e., OutWATS) to a different band. This charge does not apply to 800/877/888 (InWATS) service.

The Switched Access Ordering Charge also applies to requests to activate additional trunks or to increase BHMC on existing Switched Transport Facilities and, changes in the type of Feature Group or Direct-Trunked Transport, for any modifications or changes to existing services that are not considered an administrative change as described in 4.5.2(A)(3)(g). This would include activities such as:

- Changes and/or additions to end office services optional arrangements (changes in hunt group or screening arrangements).
- The combination or splitting of FGA or BSA-A hunt groups.
- A move to a new point of termination within the same CDL.
- Changes of a telephone number for FGA or BSA-A or Special Access Lines used with a Switching Interface.
- The activation or deactivation of 500 or 900 SAC NXX codes on a per tandem level or end office basis.
- The addition of Operator Services to an existing service.
- Changes to or additions of Basic Service Elements (BSEs) associated with an established Basic Serving Arrangement.

WN U-16
ZiPLY Fiber

Original Sheet 237

FACILITIES FOR INTRASTATE ACCESS

4. SWITCHED ACCESS (Cont'd)

4.5 Rate and Charge Regulations (Cont'd)

4.5.2 Rate Regulations (Cont'd)

(A) Types of Rates and Charges (Cont'd)

(3) Nonrecurring Charges (Cont'd)

(f) Switched Access Ordering Charges (Cont'd)

The Switched Access Ordering Charge will not apply to requests where the customer has existing FGB or BSA-B and/or FGD or BSA-D at a Telephone Company access tandem and the customer wants to add FGB or BSA-B and/or FGD or BSA-D to a subtending end office which is converting to equal access, and the request does not involve physical changes, additions or deletions to the existing facilities.

The Switched Access Ordering Charge will not apply to requests where the customer has existing FGB or BSA-B and/or FGD or BSA-D and the customer wants to add a new CIC Code to those existing facilities (except as noted above).

(g) Service Rearrangements

Service rearrangements are changes to existing (installed) services, which may be administrative only in nature or involve an actual physical change in service.

Changes in the type of Entrance Facility will be treated as a discontinuance of one type of service and a start of another. The Service Installation charge shall apply to the new Entrance Facility installation.

Changes in the physical location of the point of termination are treated as moves which are described and charged for as in 4.5.2(A)(3)(k).

Changes in name or ownership or transfer of responsibility from one customer to another requires the discontinuance of service and the start of a new service when an interruption or relocation of service is involved. The Switched Access Ordering Charge and Service Installation Charge, if appropriate, and any appropriate Minimum Period Charges will apply per service change.

WN U-16
Zipty Fiber

Original Sheet 238

FACILITIES FOR INTRASTATE ACCESS

4. SWITCHED ACCESS (Cont'd)

4.5 Rate and Charge Regulations (Cont'd)

4.5.2 Rate Regulations (Cont'd)

(A) Types of Rates and Charges (Cont'd)

(3) Nonrecurring Charges (Cont'd)

(g) Service Rearrangements (Cont'd)

Administrative changes will be made without charge to the customer. Administrative changes are as follows:

- Change in name or ownership or transfer of responsibility from one customer to another, provided there is no interruption of use or relocation of Switched Access service.
- Change of customer or customer's end user premise address when the change of address is not a result of a physical relocation of equipment,
- Change in billing data (name, address or contact name or telephone number),
- Change in customer circuit identification,
- Change of billing account number,
- Change of customer testline number,
- Change of customer or customer's end user contact name or telephone number, and
- Change of agency authorization

WN U-16
Zipty Fiber

Original Sheet 239

FACILITIES FOR INTRASTATE ACCESS

4. SWITCHED ACCESS (Cont'd)

4.5 Rate and Charge Regulations (Cont'd)

4.5.2 Rate Regulations (Cont'd)

(A) Types of Rates and Charges (Cont'd)

(3) Nonrecurring Charges (Cont'd)

(g) Service Rearrangements (Cont'd)

If the charge involves only rollover or grooming, then no charges will apply. A rollover is the retermination of a segment of a lower capacity switched transport entrance facility onto a higher capacity switched transport entrance facility. The rollover must occur in the wire center where the higher capacity service is multiplexed with no other changes to the lower capacity service being reterminated (i.e., the segment must not require rerouting to connect to the multiplexer of the higher capacity service).

Grooming is the retermination of a lower capacity switched transport entrance facility from one channel in a higher capacity switched transport entrance facility to another channel in the same higher capacity service or to another channel in another higher capacity switched transport entrance facility (i.e., change in connecting facility assignment) in the same wire center, with no other changes to the lower capacity service.

WN U-16
Zipty Fiber

Original Sheet 240

FACILITIES FOR INTRASTATE ACCESS

4. SWITCHED ACCESS (Cont'd)

4.5 Rate and Charge Regulations (Cont'd)

4.5.2 Rate Regulations (Cont'd)

(A) Types of Rates and Charges (Cont'd)

(3) Nonrecurring Charges (Cont'd)

(g) Service Rearrangements (Cont'd)

**EXAMPLE: ROLLOVER OF AN ENTRANCE FACILITY
CURRENT CONFIGURATION
BEFORE ROLLOVER OF SERVICE**

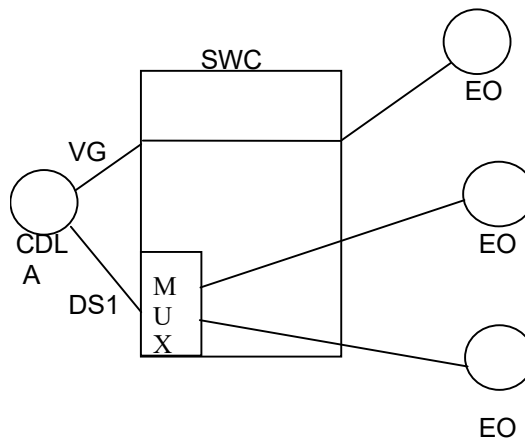

WN U-16
Zipty Fiber

Original Sheet 241

FACILITIES FOR INTRASTATE ACCESS

4. SWITCHED ACCESS (Cont'd)

4.5 Rate and Charge Regulations (Cont'd)

4.5.2 Rate Regulations (Cont'd)

(A) Types of Rates and Charges (Cont'd)

(3) Nonrecurring Charges (Cont'd)

(g) Service Rearrangements (Cont'd)

**EXAMPLE: ROLLOVER OF AN ENTRANCE FACILITY
NEW CONFIGURATION**

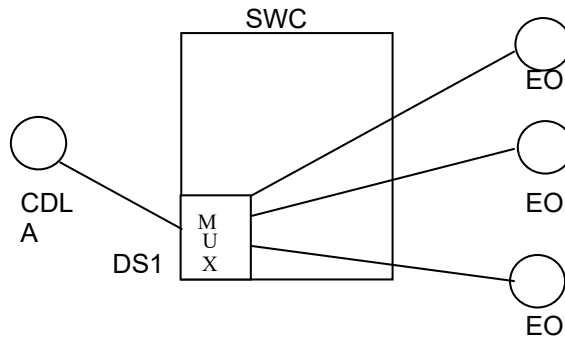

WN U-16
ZiPLY Fiber

Original Sheet 242

FACILITIES FOR INTRASTATE ACCESS

4. SWITCHED ACCESS (Cont'd)

4.5 Rate and Charge Regulations (Cont'd)

4.5.2 Rate Regulations (Cont'd)

(A) Types of Rates and Charges (Cont'd)

(3) Nonrecurring Charges (Cont'd)

(g) Service Rearrangements (Cont'd)

**EXAMPLE 2 - ROLLOVER OF AN ENTRANCE FACILITY
Current Configuration**

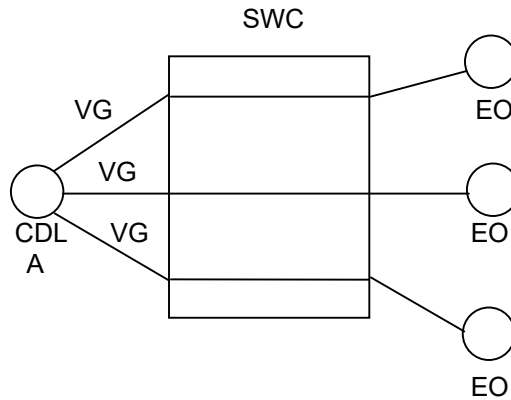

WN U-16
Zipty Fiber

Original Sheet 243

FACILITIES FOR INTRASTATE ACCESS

4. SWITCHED ACCESS (Cont'd)

4.5 Rate and Charge Regulations (Cont'd)

4.5.2 Rate Regulations (Cont'd)

(A) Types of Rates and Charges (Cont'd)

(3) Nonrecurring Charges (Cont'd)

(g) Service Rearrangements (Cont'd)

**EXAMPLE 2 - ROLLOVER OF AN ENTRANCE FACILITY
New Configuration**

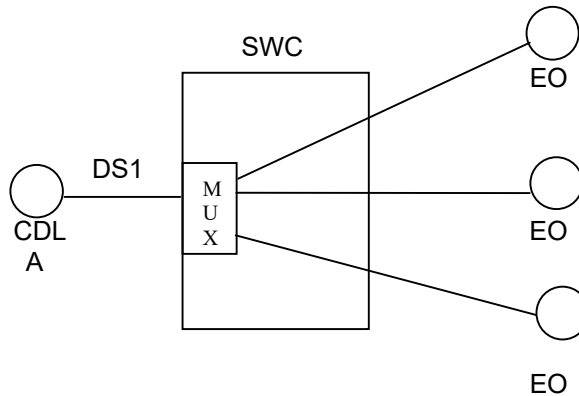

WN U-16
Zipty Fiber

Original Sheet 244

FACILITIES FOR INTRASTATE ACCESS

4. SWITCHED ACCESS (Cont'd)

4.5 Rate and Charge Regulations (Cont'd)

4.5.2 Rate Regulations (Cont'd)

(A) Types of Rates and Charges (Cont'd)

(3) Nonrecurring Charges (Cont'd)

(g) Service Rearrangements (Cont'd)

**GROOMING OF AN ENTRANCE FACILITY
Current Configuration**

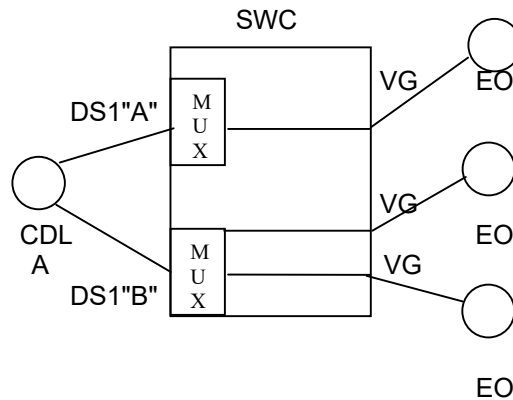

WN U-16
Zipty Fiber

Original Sheet 245

FACILITIES FOR INTRASTATE ACCESS

4. SWITCHED ACCESS (Cont'd)

4.5 Rate and Charge Regulations (Cont'd)

4.5.2 Rate Regulations (Cont'd)

(A) Types of Rates and Charges (Cont'd)

(3) Nonrecurring Charges (Cont'd)

(g) Service Rearrangements (Cont'd)

**GROOMING OF AN ENTRANCE FACILITY
Current Configuration**

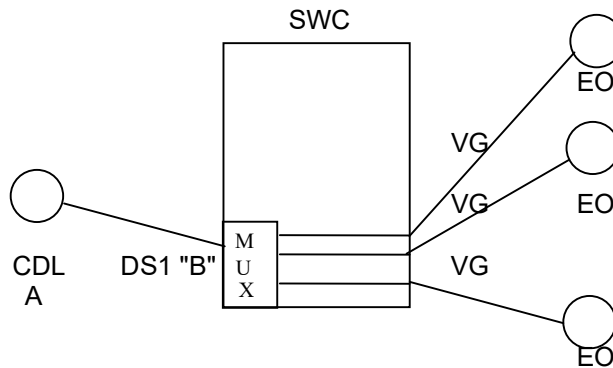

WN U-16
Zipty Fiber

Original Sheet 246

FACILITIES FOR INTRASTATE ACCESS

4. SWITCHED ACCESS (Cont'd)

4.5 Rate and Charge Regulations (Cont'd)

4.5.2 Rate Regulations (Cont'd)

(A) Types of Rates and Charges (Cont'd)

(3) Nonrecurring Charges (Cont'd)

(h) Design Change Charge

A design change is any change to a pending ASR or a change to an existing service which requires engineering review. Design changes may include the addition or deletion of End Office Services Optional Arrangements or changes in the signaling arrangements associated with the Entrance Facilities as described in 4.2.3(B). Design changes do not include a change of Switched Access Entrance Facilities or facility type, IC CDL, end user premises, end office switch, or Feature Group type or Basic Serving Arrangements type. Changes of this nature will require the issuance of a new ASR and the cancellation of the original ASR with the appropriate cancellation charges applied.

The Telephone Company will review the requested change, notify the customer whether the change can be accommodated and if a new service date is required. If the customer authorizes the Telephone Company to proceed with the design change, a Design Change Charge will apply.

The Design Change Charge for Switched Access Service as found in Section 4.6.1(A) will apply on a per ASR per occurrence basis for each request requiring a design change.

The Design Change Charge is in addition to any Switched Ordering charges associated with the change requested.

If a change of service date is required, the Service Date Change Charge in 3.2.2(A) will also apply.

(i) Installation Charge for FGA or BSA-A Optional Toll Blocking Arrangements

This charge applies per FGA or BSA-A line equipped with either of the optional call blocking arrangements in Section 4.2.5(D) and (E); InterLATA Call Denial on Line or Hunt Group, or Call Denial on Line or Hunt Group Outside the Access Area. This charge applies in addition to applicable Switched Access Ordering Charges.

WN U-16
Zipty Fiber

Original Sheet 247

FACILITIES FOR INTRASTATE ACCESS

4. SWITCHED ACCESS (Cont'd)

4.5 Rate and Charge Regulations (Cont'd)

4.5.2 Rate Regulations (Cont'd)

(A) Types of Rates and Charges (Cont'd)

(3) Nonrecurring Charges (Cont'd)

(j) Change of Switched Access Type

Changes from one type of Switched Access to another including the change from Feature Group to Basic Serving Arrangement or the change from Basic Serving arrangement to Feature Group will be treated as a discontinuance of one type of FIA and start of another. The Switched Access Installation and Ordering Charges will apply with the following exceptions:

- (1) When a customer upgrades a FGA, FGB, or FGC to a FGD at the same first point of switching, the charge will not apply. If however, optional features are added to the service at the time the conversion takes place, the Ordering Charge for these additions will apply.
- (2) When a customer upgrades a BSA-A, BSA-B, or BSA-C to a BSA-D at the same first point of switching, the charge will not apply. If however, a BSE(s) is added to the service at the time the conversion takes place, the Switched Access Ordering Charge for these additions will apply.
- (3) Where a customer has Feature Group B (FGB) and Feature Group D (FGD) at a Telephone Company access tandem, the following application of charges will apply for end office conversions:
 - a) Where FGB service exists at an end office the customer may retain the FGB service or upgrade the FGB service to FGD service with the equal access conversion. When the customer requests no physical changes or trunking additions/deletions to the existing facilities, but elects to upgrade the service or retain the existing service, the ordering charge will not apply.

WN U-16
Zipty Fiber

Original Sheet 248

FACILITIES FOR INTRASTATE ACCESS

4. SWITCHED ACCESS (Cont'd)

4.5 Rate and Charge Regulations (Cont'd)

4.5.2 Rate Regulations (Cont'd)

(A) Types of Rates and Charges (Cont'd)

(3) Nonrecurring Charges (Cont'd)

(j) Change of Switched Access Type (Cont'd)

(3) (Cont'd)

- b) Where FGB and/or FGD service exists at a Telephone Company access tandem but does not exist at an end office and the customer now wants to add FGB and/or FGD to the end office, the ordering charge will not apply to add the service when the customer requests no physical changes, additions, or deletions to the customer's existing facilities.
- c) Where FGB and/or FGD service exists at a Telephone Company access tandem and FGB also exists at the end office and the customer wants to retain the FGB service but add FGD service with equal access conversion, the ordering charge will not apply to add the FGD service when the customer requests no physical changes, additions, or deletions to the customer's existing facilities.

FACILITIES FOR INTRASTATE ACCESS

4. SWITCHED ACCESS (Cont'd)

4.5 Rate and Charge Regulations (Cont'd)

4.5.2 Rate Regulations (Cont'd)

(A) Types of Rates and Charges (Cont'd)

(3) Nonrecurring Charges (Cont'd)

(j) Change of Switched Access Type (Cont'd)

(4) Where a customer has BSA-B and BSA-D at a Telephone Company access tandem, the following application of charges will apply for end office conversions:

- a) Where BSA-B service exists at an end office the customer may retain the BSA-B service or upgrade the BSA-B service to BSA-D service with the equal access conversion. When the customer requests no physical changes or trunking additions/deletions to the existing facilities, but elects to upgrade the service or retain the existing service, the ordering charge will not apply.
- b) Where BSA-B and/or BSA-D service exists at a Telephone Company access tandem but does not exist at an end office and the customer now wants to add BSA-B and/or BSA-D to the end office, the ordering charge will not apply to add the service when the customer requests no physical changes, additions, or deletions to the customer's existing facilities.
- c) Where BSA-B and/or BSA-D service exists at a Telephone Company access tandem and BSA-B also exists at the end office and the customer wants to retain the BSA-B service but add BSA-D service with the equal access conversion, the ordering charge will not apply to add the BSA-D service when the customer requests no physical changes, additions, or deletions to the customer's existing facilities.

WN U-16
ZiPLY Fiber

Original Sheet 250

FACILITIES FOR INTRASTATE ACCESS

4. SWITCHED ACCESS (Cont'd)

4.5 Rate and Charge Regulations (Cont'd)

4.5.2 Rate Regulations (Cont'd)

(A) Types of Rates and Charges (Cont'd)

(3) Nonrecurring Charges (Cont'd)

(k) Moves

A move involves a change in the physical location of the point of termination of Switched Access. The charge for the move depends on whether the move is within the same CDL or to a different CDL.

(1) Same CDL

When the move is to a new point within the same CDL, the Switched Access Ordering Charge in 4.6.1(A) will apply. There will be no change in the minimum period requirements. For services subject to payment plan regulations the same payment plan will remain in force.

(2) A Different CDL

When the move is to a different CDL it will be treated as a disconnect and an installation of Switched Access. The Switched Access Ordering Charges, as specified in 4.6.1(A) will apply to the Switched Access, installed at the CDL. A new minimum period will also be established for the installed Switched Access. The customer will remain responsible for all remaining minimum period charges associated with the disconnected Switched Access. For services subject to payment plan regulations the same payment plan will remain in force.

(B) 800/877/888 Data Base Query Service

Information concerning 800/877/888 Data Base Query Service can be found in the Concurrence section of this tariff.

WN U-16
ZiPLY Fiber

Original Sheet 251

FACILITIES FOR INTRASTATE ACCESS

4. SWITCHED ACCESS (Cont'd)

4.5 Rate and Charge Regulations (Cont'd)

4.5.2 Rate Regulations (Cont'd)

(C) Network Blocking Charge for Tandem Switched FGB, FGC, FGD, BSA-B, BSA-C, BSA-D and SAC Access Service

The customer will be notified by the Telephone Company to increase its capacity when excessive trunk group blocking occurs on groups carrying FGB, FGC, FGD, BSA-B, BSA-C, BSA-D or SAC Access Service traffic and the measured Access Minutes for the Daily Busiest Hour exceed the capacity purchased. Excessive trunk group blocking occurs when the blocking thresholds stated below are exceeded. They are predicated on Daily Busiest Hour measurements for four contiguous weeks using the five highest traffic days of the week, excluding national holidays. The Telephone Company will not bill the customer a Network Blocking Charge if additional capacity is available and the ASR for additional capacity is received by the Telephone Company within 15 days of the notification. The Telephone Company will bill the customer a Network Blocking Charge if additional capacity is unavailable for the period beginning 15 days after the notification date until the in-service date for additional capacity, at the rate in 4.6.1(C), for each overflow in excess of the blocking threshold when (1) the Daily Busiest Hour average blocking for the four contiguous weeks exceeds the threshold level and (2) the average originating or two-way usage measured for these same hours exceeds the Switched Access capacity purchased.

Blocking Thresholds

Trunks in Service	1%	1/2%
1-2	.070	.045
3-4	.050	.035
5-6	.040	.025
7-or more	.030	.020

The one percent blocking threshold is for FGB, FGC, BSA-B, BSA-C and SAC Access Service transmission paths carrying traffic between a CDL and the first point of switching, or FGD transmission paths carrying traffic direct between a CDL and an end office. The one-half percent blocking threshold is for FGD transmission paths carrying traffic between a CDL and an end office via an access tandem.

WN U-16
ZiPLY Fiber

Original Sheet 252

FACILITIES FOR INTRASTATE ACCESS

4. SWITCHED ACCESS (Cont'd)

4.5 Rate and Charge Regulations (Cont'd)

4.5.2 Rate Regulations (Cont'd)

(D) Determination of Intrastate Charges for Mixed Interstate and Intrastate Switched Access

When mixed interstate and intrastate Switched Access Service is provided, all charges will be prorated based on the jurisdictional distribution of access minutes as in 4.3.2 and 4.3.3. The portion of a Switched Access Service to be charged as intrastate is determined in the following manner:

- For usage rated elements, multiply the percent intrastate use times the total usage, either measured or assumed, rounded to whole access minutes times the appropriate tariff rate element.
- For monthly and nonrecurring rate elements, multiply the percent intrastate use times the quantity of each chargeable element times the stated tariff rate per element.

(E) Local Dial-It Services

Customers will be billed charges for terminating Switched Access calls to certain community information services, for which rates are applicable under the Telephone Company Local Tariffs (e.g., 976 Dial-It Network Services).

(F) Local Directory Assistance

Terminating Switched Access calls dialed to local directory assistance will be rated under the applicable rates for the Switched Access in 4.6. In addition, the charge per call to Directory Assistance as described in the Telephone Company Local Tariffs may also apply.

(G) Signaling System 7 (SS7) Out of Band Signaling

- (1) Switched Access Ordering Charges will apply for a change in FGD switched access and 800/877/888 SAC Access signaling from multifrequency address signaling to SS7 Out of Band Signaling.
 - (2) Switched Access Ordering Charges will not apply if CPN Parameter, CSP Parameter and/or CN Parameter are ordered at the same time as SS7 Out of Band Signaling is ordered with FGD. Switched Access Ordering Charges will apply if these optional features are ordered subsequent to the provision of SS7 Out of Band Signaling.
-

WN U-16
Zipty Fiber

Original Sheet 253

FACILITIES FOR INTRASTATE ACCESS

4. SWITCHED ACCESS (Cont'd)

4.5 Rate and Charge Regulations (Cont'd)

4.5.2 Rate Regulations (Cont'd)

(H) Description and Application of Rates

(1) Determination of Premium Rates and Nonpremium Rates

The Interconnection Charge, End Office Switching and the Information Surcharge rates are applied either as premium or nonpremium rates at the amounts specified in 4.6.

The specific application of premium and nonpremium rates for a specific customer is dependent upon the Feature Group or Basic Serving Arrangement, and the availability of equal access capabilities in the end office to which the service is provided. The Entrance Facility, Direct-Trunked Transport, Tandem-Switched Transport and Multiplexing rate elements are not subject to premium and nonpremium rating.

Premium rates apply to all FGC, FGD, BSA-C and BSA-D access minutes and to all FGA, FGB, BSA-A, BSA-B and SAC Access Service access minutes that originate from or terminate at end offices or WATS Serving Offices equipped with equal access (i.e., FGD or BSA-D) capabilities. Premium rates also apply to all FGB access minutes that originate from or terminate at end offices not equipped with equal access, when the service is provided to customers who furnish MTS and WATS.

Premium rates apply to all BSEs provided at end offices and access tandems equipped with equal access and to all BSEs provided with BSA-B access minutes that terminate at end offices not equipped with equal access, when the service is provided to customers who furnish MTS and WATS.

FACILITIES FOR INTRASTATE ACCESS

4. SWITCHED ACCESS (Cont'd)4.5 Rate and Charge Regulations (Cont'd)4.5.2 Rate Regulations (Cont'd)(H) Description and Application of Rates (Cont'd)(1) Determination of Premium Rates and Nonpremium Rates (Cont'd)

Nonpremium rates (i.e., discounted access minute rates) apply to all FGA, FGB, BSA-A, BSA-B and SAC Access Service access minutes (measured or assumed) that originate from or terminate at end offices which are not equipped with equal access capabilities, except for FGB or BSA-B access minutes generated by providers of MTS and WATS.

Nonpremium rates apply to all BSEs provided at end offices or access tandems not equipped with equal access except when such BSEs are provided in conjunction with BSA-B access minutes that terminate at end offices not equipped with equal access, when the service is provided to customers who furnish MTS and WATS.

When an Access Area has a mixture of equal access and nonequal access end offices and end office specific usage measurement is not available, the provisions as described in 4.5.2(H)(6) will be used to determine the application of premium rates or nonpremium rates.

(2) Switched Transport

Switched Transport is determined as follows:

- (a) The Tandem-Switched Transport - Facility rate is applied per access minute per airline mile for each Switched Access Feature Group or Basic Serving Arrangement type. Tandem-Switched Transport - Facility airline mileage will be determined as follows:

Where Tandem-Switched Transport is ordered between a serving wire center and end offices subtending an access tandem, mileage will be measured from the serving wire center that normally serves the CDL to the end office or WSO (for WATS and WATS-type).

Where Direct-Trunked Transport is ordered between a serving wire center and an access tandem, and Tandem-Switched Transport is ordered to subtending end offices, mileage will be measured from the access tandem to the end office or WSO (for WATS and WATS-type)¹.

Note¹: Due to billing constraints, the ordering of Tandem-Switched Transport in conjunction with Direct-Trunked Transport is prohibited until the billing system can accommodate this service.

WN U-16
ZiPLY Fiber

Original Sheet 255

FACILITIES FOR INTRASTATE ACCESS

4. SWITCHED ACCESS (Cont'd)

4.5 Rate and Charge Regulations (Cont'd)

4.5.2 Rate Regulations (Cont'd)

(H) Description and Application of Rates (Cont'd)

(2) Switched Transport (Cont'd)

For either of the above Tandem-Switched Transport configurations, when the end office is acting as a host office, a separate mileage calculation determines the mileage from the host office to the remote office. Traffic originating from and/or terminating to the remote will be billed Tandem-Switched Transport charges. The Tandem Switching charge does not apply to traffic between a host and remote office.

The V&H coordinate method is used to determine the actual mileage as specified in NECA Tariff FCC No. 4. If the calculated miles include a fraction, the value is rounded up to the next full mile.

Where Tandem-Switched Transport - Facility is provided by more than one telephone company, the mileage for each will be determined as in 2.7.

The Tandem-Switched Transport - Facility rate will not apply if the CDL serving wire center and the end office are co-located (where $V/H - V/H = 0$).

(b) The Tandem-Switched Transport - Termination rate applies per access minute for each termination (i.e., the first point of switching and the end office serving the end user) for all Switched Access Feature Group or Basic Serving Arrangement types. When both terminations are provided by the Telephone Company, the Tandem-Switched Transport - Termination rate applies twice, including those situations when the terminations are co-located.

Where the Tandem-Switched Transport - Facility is provided by more than one telephone company, the Tandem-Switched Transport - Termination rate applies for the termination (i.e., the first point of switching or the end office serving the end user) at the Telephone Company end of the Switched Transport as in 2.7. The Tandem-Switched Transport - Termination rate will not apply when the Telephone Company is the intermediate provider of the Tandem-Switched Transport - Facility.

FACILITIES FOR INTRASTATE ACCESS

4. SWITCHED ACCESS (Cont'd)4.5 Rate and Charge Regulations (Cont'd)4.5.2 Rate Regulations (Cont'd)(H) Description and Application of Rates (Cont'd)(2) Switched Transport (Cont'd)

- (c) For FGA or BSA-A, the Entrance Facility charge shall apply between the CDL and the serving wire center of the CDL. If the serving wire center is not the dial tone office, Direct-Trunked Transport shall apply between the serving wire center and the dial tone office. Tandem-Switched Transport (Facility and Termination) rates, excluding the Tandem Switching charge, shall apply between the dial tone office and the end office for FGA or BSA-A traffic that originates and/or terminates within the FGA or BSA-A Access Area. For FGA or BSA-A traffic that terminates beyond the FGA or BSA-A Access Area, Switched Transport rates apply as described in 4.5.2(H)(3).
- (d) The Direct-Trunked Transport rate is applied on a monthly airline mile and termination basis, except that Direct-Trunked Voiceband Transport is applied on a monthly airline mile basis only.

To determine the Direct-Trunked Transport airline mileage, the distance will be measured from the wire center that normally serves the CDL to the access tandem, end office, WSO (for WATS and WATS-type), or the end office that serves as the host for a remote office. The V&H coordinate method is used to determine the actual mileage as specified in NECA Tariff FCC No. 4. If the calculated miles include a fraction, the value is rounded up to the next full mile.

For traffic originating from or terminating to a remote office, the mileage will be calculated separately from the end office switch that serves as the host to the remote using the V&H coordinates method. The Direct-Trunked Transport Rate applies from the customer's serving wire center to the end office that serves as the host office. Traffic originating from and/or terminating to the remote will be billed Tandem-Switched Transport charges based on mileage between the host and remote office. The Tandem Switching Charge is not applicable for Tandem-Switched Transport between the end office that serves as the host to the remote office.

When Telephone Company Hubs are involved, mileage is computed and rates applied separately for each section of the Direct-Trunked Transport, i.e., customer serving wire center to Hub, Hub to Hub, Hub to Tandem or Hub to end office.

Where Direct-Trunked Transport includes termination rates, i.e., High Capacity DS1 and DS3 transport, one Termination rate applies for the termination of each end of the interoffice facility.

FACILITIES FOR INTRASTATE ACCESS

4. SWITCHED ACCESS (Cont'd)4.5 Rate and Charge Regulations (Cont'd)4.5.2 Rate Regulations (Cont'd)(H) Description and Application of Rates (Cont'd)(2) Switched Transport (Cont'd)

- (e) The Entrance Facility rate is a flat-rated charge assessed per Voiceband, DS1 or DS3 termination at the CDL. This charge will apply even if the CDL and the serving wire center are co-located in a Telephone Company building.

For DS1 Entrance Facilities, a "First System" charge is assessed per Entrance Facility for the first DS1 ordered. When the same customer requests additional DS1 service on the same ASR to be installed at the same time between the same CDL and serving wire center, the "Additional System" charge will apply.

- (f) The Tandem Switching rate is usage-sensitive and is applied per access minute to all feature groups for Tandem-Switched Transport with two exceptions. The Tandem-Switching Rate is not applicable for Tandem-Switched Transport between a host office and a remote office, nor is it applicable for FGA or BSA-A.
- (g) The Interconnection rate is usage-sensitive and is applied per access minute to all feature groups that utilize the Telephone Company's switched access network. It applies to all minutes of use whether transported via Direct-Trunked Transport, Tandem-Switched Transport or Entrance Facilities.
- (h) When the Alternate Traffic Routing optional arrangement is provided with Feature Groups B and D or BSA-B and BSA-D and the end office or Telephone Company access tandem switch is unable to determine the specific trunk group carrying alternate routed traffic to multiple CDLs, switched transport access minutes will be apportioned among the number of trunk groups utilized to provide this optional arrangement. Such apportionment will occur through the application of Percent Traffic Routed (PTR) values provided by the customer on the ASR. The PTR value for each trunk group, the percentage of total traffic to be attributed to each trunk group, will be determined by dividing the BHMC for each trunk group by the total BHMC for all trunk groups carrying alternate routed traffic. The resulting percentage, or PTR value, for each trunk group will be multiplied times the total alternate routed traffic quantity to apportion usage to the individual trunk group. This apportionment will serve as the basis for the switched transport mileage calculation for alternate routed originating traffic as described herein.
-

WN U-16
ZiPLY Fiber

Original Sheet 258

FACILITIES FOR INTRASTATE ACCESS

4. SWITCHED ACCESS (Cont'd)

4.5 Rate and Charge Regulations (Cont'd)

4.5.2 Rate Regulations (Cont'd)

(H) Description and Application of Rates (Cont'd)

(2) Switched Transport (Cont'd)

(h) (Cont'd)

When Feature Group B or D or BSA-B or BSA-D Switched Access service is terminated from multiple CDLs through a Telephone Company access tandem or is terminated from multiple CDLs directly to an end office and the end office or Telephone Company access tandem is unable to determine the specific trunk group carrying such terminating traffic, switched transport access minutes will be apportioned among the number of trunk groups carrying such terminating traffic. Such apportionment will occur through the application of PTR values provided by the customer on the ASR. The PTR value for each trunk group will be determined by dividing the BHMC for each trunk group by the total BHMC for all trunk groups carrying such terminating traffic. The resulting PTR value for each trunk group will be multiplied times the total terminating traffic quantity to apportion usage to the individual trunk group. This apportionment will serve as the basis for the switched transport mileage calculation for traffic terminating from multiple CDLs as described herein.

The PTR values as described herein must be included on any ASR establishing or changing any Switched Access service arrangement requiring the use of PTRs. The notation of such PTR values on ASRs must indicate whether the PTR will be used to apportion alternate routed originating traffic to multiple CDLs or to apportion traffic terminating from multiple CDLs. The Telephone Company may conduct verification audits, not to exceed one each year, for each customer, and for each location. Such audits may be conducted by independent auditors if the Telephone Company and the customer, or the customer alone, is willing to pay the expense.

WN U-16
ZiPLY Fiber

Original Sheet 259

FACILITIES FOR INTRASTATE ACCESS

4. SWITCHED ACCESS (Cont'd)

4.5 Rate and Charge Regulations (Cont'd)

4.5.2 Rate Regulations (Cont'd)

(H) Description and Application of Rates (Cont'd)

(3) Extended FGA and BSA-A Terminating Traffic

(a) For calls established on a 1+ basis outside the specific FGA Access Area, however inside the LATA, with terminating FGA traffic to an end office equipped with equal access capabilities, the following rates apply for each access minute of each such call:

- the premium rates for End Office Switching, in 4.6.3, the Information Surcharge in 4.6.4 and the Interconnection Charge in 4.6.2.
- for each access minute, the Tandem-Switched Transport Facility rate per access minute per airline mile in 4.6.2 and the Tandem-Switched Transport - Termination in 4.6.2.

When the serving wire center of the CDL is the dial tone office, the Tandem-Switched Transport - Facility rate is applicable and mileage is measured from the serving wire center (i.e., the dial tone office) of the CDL to the end office.

When the serving wire center of the CDL is not the dial tone office, the Direct-Trunked Transport rate is applicable for mileage measured between the serving wire center of the CDL and the dial tone office. The Tandem-Switched Transport - Facility rate is applicable for mileage measured between the dial tone office and the end office.

The Tandem Switching rate is not applicable for Extended FGA or BSA-A terminating traffic.

(b) For calls established on a 1+ basis, outside the specific FGA or BSA-A Access Area, however inside the LATA, with terminating FGA or BSA-A traffic to an end office not equipped with Equal Access capabilities, the following rates apply:

- for each access minute, the nonpremium rates per access minute for End Office Switching, in 4.6.3, the Information Surcharge in 4.6.4., and the Interconnection Charge in 4.6.2.
 - for each access minute, the Tandem-Switched Transport - Facility rate per access minute per airline mile in 4.6.2 and the Tandem-Switched Transport - Termination in 4.6.2.
-

WN U-16
Zipty Fiber

Original Sheet 260

FACILITIES FOR INTRASTATE ACCESS

4. SWITCHED ACCESS (Cont'd)

4.5 Rate and Charge Regulations (Cont'd)

4.5.2 Rate Regulations (Cont'd)

(H) Description and Application of Rates (Cont'd)

(3) Extended FGA and BSA-A Terminating Traffic (Cont'd)

(b) (Cont'd)

When the serving wire center of the CDL is the dial tone office, the Tandem-Switched Transport - Facility rate is applicable and mileage is measured from the serving wire center (i.e., the dial tone office) of the CDL to the end office.

When the serving wire center of the CDL is not the dial tone office, the Direct-Trunked Transport rate is applicable for mileage measured between the serving wire center of the CDL and the dial tone office. The Tandem-Switched Transport - Facility rate is applicable for mileage measured between the dial tone office and the end office.

(4) Equal Access Notification

The Telephone Company will provide written notification to all of its customers of record operating within a particular LATA that an end office in that LATA is scheduled to be converted to an equal access end office. This notification will be sent, via U.S. Mail, to each Telephone Company customer of record operating in the LATA where the conversion is scheduled to occur, at least twelve months before the conversion date.

The customer will have the choice of converting existing services to equal access (i.e., Feature Group D) at no charge or retaining the existing services (with the exception of FGC). Premium rates will apply to the total Access Minutes beginning on the actual conversion date, whether the customer chooses to convert to FGD or retain existing services.

WN U-16
ZiPLY Fiber

Original Sheet 261

FACILITIES FOR INTRASTATE ACCESS

4. SWITCHED ACCESS (Cont'd)

4.5 Rate and Charge Regulations (Cont'd)

4.5.2 Rate Regulations (Cont'd)

(H) Description and Application of Rates (Cont'd)

(4) Equal Access Notification (Cont'd)

Where a customer has Feature Group B (FGB) and Feature Group D (FGD) at a Telephone Company access tandem, the following application of charges will apply for end office conversions:

- Where FGB service exists at an end office the customer may retain the FGB service or upgrade the FGB service to FGD service in conjunction with equal access conversion. When the customer requests no physical changes or trunking additions/deletions to the existing facilities, the ordering charge will not apply to retain the existing service or upgrade.
- Where FGB and/or FGD service exists at a Telephone Company access tandem but does not exist at an end office and the customer now wants to add FGB and/or FGD to the end office, the ordering charge will not apply to add the service when the customer requests no physical changes, additions, or deletions to the customer's existing facilities.
- Where FGB and/or FGD service exists at a Telephone Company access tandem and FGB also exists at the end office and the customer wants to retain the FGB service but add FGD service with the equal access conversion, the ordering charge will not apply to add the FGD service when the customer requests no physical changes, additions, or deletions to the customer's existing facilities.

Premium rates will apply to the total Access Minutes beginning on the actual conversion date, whether the customer chooses to convert to FGD or retain existing services.

Where a customer has BSA-B and BSA-D at a Telephone Company access tandem, the following application of charges will apply for end office conversions:

- Where BSA-B service exists at an end office the customer may retain the BSA-B service or upgrade the BSA-B service to BSA-D service with equal access conversion. When the customer requests no physical changes or trunking additions/deletions to the existing facilities, the ordering charge will not apply to retain the existing service or upgrade.

Issued: July 29, 2020
Issued by ZiPLY Fiber
By Jessica Epley, Regulatory & External Affairs Director

Effective: July 31, 2020

FACILITIES FOR INTRASTATE ACCESS

4. SWITCHED ACCESS (Cont'd)4.5 Rate and Charge Regulations (Cont'd)4.5.2 Rate Regulations (Cont'd)(H) Description and Application of Rates (Cont'd)(4) Equal Access Notification (Cont'd)

- Where BSA-B and/or BSA-D service exists at a Telephone Company access tandem but does not exist at an end office and the customer now wants to add BSA-B and/or BSA-D to the end office, the ordering charge will not apply to add the service when the customer requests no physical changes, additions, or deletions to the customer's existing facilities.
- Where BSA-B and/or BSA-D service exists at a Telephone Company access tandem and BSA-B also exists at the end office and the customer wants to retain the BSA-B service but add BSA-D service with the equal access conversion, the ordering charge will not apply to add the BSA-D service when the customer requests no physical changes, additions, or deletions to the customer's existing facilities.

(5) End Office Switching

When equal access becomes available, premium rates for end office switching will apply.

(6) Transitional Billing Arrangements

Transitional billing arrangements apply when FGA, FGB, BSA-A or BSA-B Switched Access Service is provided to a first point of switching (i.e., dial tone office for FGA and BSA-A and an access tandem for FGB and BSA-B) which has usage originating from and/or terminating at both end offices that have been converted to equal access and end offices that have not been converted. Transitional billing will occur in the following manner:

- (a) Premium and nonpremium rates for Switched Access Service (including the Carrier Common Line Charge) will apply as discussed in 4.5.2(H)(1), except as in (b)(ii).
 - (b) The number of access minutes to be rated as premium or nonpremium access minutes is determined as follows:
 - (i) Where measurement capability exists, and end office specific usage data is available, premium rates will apply as discussed in 4.5.2(H)(1).
-

WN U-16
ZiPLY Fiber

Original Sheet 263

FACILITIES FOR INTRASTATE ACCESS

4. SWITCHED ACCESS (Cont'd)

4.5 Rate and Charge Regulations (Cont'd)

4.5.2 Rate Regulations (Cont'd)

(H) Description and Application of Rates (Cont'd)

(6) Transitional Billing Arrangements (Cont'd)

(b) (Cont'd)

- (ii) Where measurement capability does not exist and/or end office specific usage data is not available, originating and/or terminating usage will be apportioned between premium and nonpremium end offices as follows. The usage to be apportioned will be the recorded usage or the assumed usage as in 4.5.2(I). Such apportionment will be based on a ratio of the number of subscriber lines in the end office containing the customer's first point of switching to the total number of subscriber lines in that Access Area. The ratio thus developed is applied to the total measured or assumed originating FGA and BSA-A usage, terminating FGA and BSA-A usage, originating FGB usage or terminating FGB and BSA-B usage, as applicable, to apportion usage among all end offices in the Access Area to determine the apportioned usage that is to be billed as premium or nonpremium.

The ratios used to apportion FGA, FGB, BSA-A and BSA-B minutes will be updated on a quarterly basis dependent upon the availability of line data from other telephone companies. The ratios to be used for the succeeding quarter will be provided to the customer with the last bill rendered in the quarter or mailed separately within five working days after the first day of the new quarter (i.e., January, April, July and October). For purposes of administering this provision: (1) subscriber lines are defined as exchange service lines, Centrex lines and Centrex-type lines provided by the Telephone Company under its Local Tariff and (2) the Access Area is defined as the local calling area of the end office switch from which the FGA or BSA-A is provided for originating and terminating FGA and BSA-A, and for all end offices sub-tending a customer selected access tandem for originating and terminating FGB and BSA-B.

WN U-16
ZiPLY Fiber

Original Sheet 264

FACILITIES FOR INTRASTATE ACCESS

4. SWITCHED ACCESS (Cont'd)

4.5 Rate and Charge Regulations (Cont'd)

4.5.2 Rate Regulations (Cont'd)

(H) Description and Application of Rates (Cont'd)

(6) Transitional Billing Arrangements (Cont'd)

(b) (Cont'd)

(iii) Where FGD or BSA-D Switched Access Service is subscribed to by a customer in an end office(s) where FGA, FGB, BSA-A or BSA-B access minutes have been allocated in accordance with (ii), such access minutes will be adjusted in the following manner.

- For each FGD or BSA-D access minute originating from or terminating at that end office, one originating or terminating FGA, FGB, BSA-A or BSA-B premium access minute allocated, as in (ii), will be reduced to nonpremium. In no event shall the reduction exceed the total number of FGA, FGB, BSA-A or BSA-B access minutes originating from or terminating at that end office.
- When FGA, FGB, BSA-A or BSA-B originating or terminating minutes are greater than the FGD or BSA-D originating or terminating minutes, the difference (the greater amount) is identified as premium FGA, FGB, BSA-A or BSA-B minutes in the equal access end office, the residual amount (i.e., the remaining minutes) in that end office is considered as nonpremium usage and billed at nonpremium rates.
- FGA, FGB, BSA-A or BSA-B minutes apportioned to end offices converted to equal access, but FGD or BSA-D is not subscribed to by the customer, will be considered as premium minutes for billing.

(c) Once the allocation for transitional billing, as in (ii) and (iii) is completed, all Switched Access rate elements will be billed based on this allocation.

Specific details and methodology used to apportion FGA, FGB, BSA-A or BSA-B minutes as described in the preceding paragraphs will be provided to the customer upon request within 15 days of the receipt of such a request.

WN U-16
Zipty Fiber

Original Sheet 265

FACILITIES FOR INTRASTATE ACCESS

4. SWITCHED ACCESS (Cont'd)

4.5 Rate and Charge Regulations (Cont'd)

4.5.2 Rate Regulations (Cont'd)

(H) Description and Application of Rates (Cont'd)

(7) Tandem Switch Signaling (TSS)

TSS will be provided via FGD or BSA-D Switched Access, 500 SAC Access, or 900 SAC Access services with either multifrequency (MF) address signaling or SS7 Out of Band Signaling. TSS is available with originating calling only, terminating calling only, or, where available, two-way calling trunks. TSS two-way calling trunks are only available from end offices where the switch technology is capable of measuring the terminating usage on two-way TSS equipped trunks. Where the end office switch technology is not capable of measuring terminating usage on two-way calling TSS equipped trunks, the customer must order originating calling only or terminating calling only trunks for use with TSS.

Switched Access connections to the customer's access tandem location(s) shall be via Direct-Trunked Transport, Entrance Facility, and/or a customer's transmission equipment and facilities using DS1 or DS3 Cross Connect arrangement where the customer is provided Expanded Interconnection Service via a Collocation agreement with the Telephone Company. The Switched Access Entrance Facility provides the facility, including interface arrangement, between the point of termination at the customer designated location and the Telephone Company's serving wire center. Direct-Trunked Transport provides the interoffice facilities dedicated to a single customer between the serving wire center and end offices. TSS is not available via a Telephone Company access tandem. The facilities ordered by the customer for connectivity from the customer's access tandem to an IC's CDL is provided via Special Access facilities as described in Section 5.

- For originating usage the owner of the carrier identification code will be billed for all usage.
- For terminating usage all associated Switched Access usage charges are the responsibility of the TSS customer. At the TSS customer's request, the Telephone Company will bill each of the TSS customer's users directly for their respective usage, if the TSS customer agrees to furnish the Telephone Company, free of charge, the call detail information necessary to bill its users. This call detail information must be provided daily for the previous day's usage in industry standard format (i.e., 1101-20 Expanded Message Record format with end office level detail). The information must be provided by either electronic transmission or magnetic tape as specified by the Telephone Company.

WN U-16
ZiPLY Fiber

Original Sheet 266

FACILITIES FOR INTRASTATE ACCESS

4. SWITCHED ACCESS (Cont'd)

4.5 Rate and Charge Regulations (Cont'd)

4.5.2 Rate Regulations (Cont'd)

(H) Description and Application of Rates (Cont'd)

(7) Tandem Switch Signaling (TSS) (Cont'd)

If the TSS customer fails to provide the call detail information or fails to provide the information in the required format within 30 days from the call activity date, then the TSS customer will be billed for that day's usage. Where the total usage measured by the Telephone Company differs from the total amount of usage provided by the TSS customer's call detail information, the Telephone Company will work cooperatively with the TSS customer to resolve the discrepancies.

The TSS customer must retain documentation in support of the billing information for a period of fifteen months after submission of the billing tapes to the Telephone Company. The Telephone Company reserves the right to audit billing tape information upon 30 days' notice to the TSS customer. In the event of a discrepancy, if final agreement cannot be reached, charges will be billed based on the results of the audit.

(8) NXX Translation Nonrecurring Charge

The NXX Translation Nonrecurring Charge in 4.6.1(B) shall apply to each 500 NXX code activated or deactivated in a Telephone Company switch capable of performing the customer identification function for 500 SAC Access Service. Nonrecurring charges apply per end office for the activation or deactivation of the first NXX code contained on the customer's ASR and to the activation or deactivation of each additional NXX code contained on the same ASR. In addition, the Switched Access Ordering Charge in 4.6.1(A) will apply per ASR submitted for the activation or deactivation of NXX codes.

(9) Dedicated Trunk Port Charge

The Dedicated Trunk Port charge, as set forth in 4.6.3(I), shall apply for termination of a dedicated trunk at the access tandem or an end office. It is flat-rated and is assessed per voicegrade or DS1 channel terminating at an end office or access tandem.

(10) Shared Trunk Port Charge

The Shared Trunk Port, as set forth in 4.6.3(I), provides for the termination of a Tandem-Switched Trunk at an end office. The Shared Trunk Port is usage rated and shall be assessed to all access minutes which utilize Tandem-Switched Transport. This includes minutes of use associated with FGA service when traffic is terminated in an end office that is not the dial tone office and on minutes of use provided at a remote office.

FACILITIES FOR INTRASTATE ACCESS

4. SWITCHED ACCESS (Cont'd)4.5 Rate and Charge Regulations (Cont'd)4.5.2 Rate Regulations (Cont'd)(H) Description and Application of Rates (Cont'd)(10) Shared Trunk Port Charge (Cont'd)

The Shared Trunk Port charge will not apply to access minutes that originate or terminate at the end office part of a Class 4/5 switch.

The Shared Trunk Port charge does not apply to switched access minutes of use that originate or terminate at MTSOs directly interconnected to a Telephone Company access tandem.

When the Tandem-Switched Transport is provided by more than one telephone company, the Shared Trunk Port charge shall be billed by the Telephone Company in whose territory the end office is located, as in 2.7.3(F).

(I) Measuring Access Minutes

Customer traffic to end offices will be measured (i.e., recorded or assumed) by the Telephone Company at end office switches or access tandem switches. Originating and terminating calls will be measured (i.e., recorded or assumed) by the Telephone Company to determine the basis for computing chargeable access minutes. For terminating calls over FGA, FGB, FGC, BSA-A, BSA-B, BSA-C (to SAC Access and Directory Assistance Services) and FGD and BSA-D, the measured access minutes are the chargeable access minutes. For originating calls over FGA, FGB, BSA-A and BSA-B the measured access minutes are the chargeable access minutes.

For originating calls over FGC or BSA-C, chargeable access minutes are derived from measured access minutes through the use of a Telephone Company factor. A description of the factor is in (4).

FGA or BSA-A access minutes, or fractions thereof, are accumulated over the billing period for each line or hunt group, and are then rounded up to the nearest access minute for each line or hunt group. FGB, FGC, FGD, BSA-B, BSA-C and BSA-D access minutes or fractions thereof, are accumulated over the billing period for each office, and are then rounded up to the nearest access minute for each end office. The exact value of the fraction is a function of the switch technology where the measurement is made.

When measurement capability for FGA, FGB, BSA-A and BSA-B is not available, access minutes shall be assumed as described in (3).

When usage data is required for a specific end office in an Access Area with multiple end offices, and usage to that office cannot be measured, a portion of total usage will be allocated to the specific end office based upon the portion of subscriber lines served by that end office.

WN U-16
ZiPLY Fiber

Original Sheet 268

FACILITIES FOR INTRASTATE ACCESS

4. SWITCHED ACCESS (Cont'd)

4.5 Rate and Charge Regulations (Cont'd)

4.5.2 Rate Regulations (Cont'd)

(I) Measuring Access Minutes (Cont'd)

(1) FGA and BSA-A Usage Measurement

For originating calls over FGA or BSA-A, usage measurement begins when the FGA or BSA-A first point of switching receives an off-hook supervisory signal forwarded from the CDL. Where FGA is used for MTS Access, this off-hook signal is generally provided by the customer's equipment. Where FGA or BSA-A is used for FCO/ONAL services, the off-hook signal is generally forwarded by the customer's equipment when the called party answers.

The measurement of originating call usage over FGA or BSA-A ends when the FGA or BSA-A first point of switching receives an on-hook supervisory signal from either the end office switch, indicating the originating end user has disconnected, or the CDL, whichever is recognized first by the first point of switching. Except that, if the on-hook supervisory signal received from the CDL is preceded by a switchhook flash signal from the CDL which transfers the call supervision function to the terminating end user's end office, the measurement of originating call usage over FGA or BSA-A ends when the originating FGA or BSA-A first point of switching receives an on-hook supervisory signal from either the originating end user's end office, indicating that the originating end user has disconnected, or the terminating end user's end office, indicating that the terminating end user has disconnected, whichever is recognized first by the FGA or BSA-A first point of switching.

For terminating calls over FGA or BSA-A, usage measurement begins when the FGA or BSA-A first point of switching receives an off-hook supervisory signal from the end office switch, indicating the terminating end user has answered. The measurement of terminating call usage over FGA or BSA-A ends when the terminating FGA first point of switching receives an on-hook supervisory signal from either the end office switch, indicating the terminating end user has disconnected, or the CDL, whichever is recognized first by the first point of switching. Except that, if the on-hook supervisory signal received from the CDL is preceded by a switchhook flash signal from the CDL which transfers the call supervision function to the terminating end user's end office, the measurement of terminating call usage over FGA or BSA-A ends when the terminating FGA or BSA-A first point of switching receives an on-hook supervisory signal from either the originating end user's end office, indicating that the originating end user has disconnected, or the terminating end user's end office, indicating that the terminating end user has disconnected, whichever is recognized first by the FGA first point of switching.

WN U-16
Zipty Fiber

Original Sheet 269

FACILITIES FOR INTRASTATE ACCESS

4. SWITCHED ACCESS (Cont'd)

4.5 Rate and Charge Regulations (Cont'd)

4.5.2 Rate Regulations (Cont'd)

(1) Measuring Access Minutes (Cont'd)

(2) FGB and BSA-B Usage Measurement

For originating calls over FGB or BSA-B, usage measurement begins when the FGB or BSA-B first point of switching receives answer supervision forwarded from the CDL, indicating the customer's equipment has answered.

The measurement of originating call usage over FGB or BSA-B ends when the FGB or BSA-B first point of switching receives disconnect supervision from either the end office switch, indicating the originating end user has disconnected, or the CDL, whichever is recognized first by the first point of switching.

For terminating calls over FGB or BSA-B, usage measurement begins when the FGB or BSA-B first point of switching receives answer supervision from the end office switch, indicating the terminating end user has answered.

The measurement of terminating call usage over FGB or BSA-B ends when the FGB or BSA-B first point of switching receives disconnect supervision from either the end office switch, indicating the terminating end user has disconnected, or the CDL, whichever is recognized first by the first point of switching.

(3) Usage Measurement Not Available For FGA, FGB, BSA-A, and BSA-B

When originating and/or terminating measurement capability does not exist, the number of access minutes per FGA or BSA-A line or FGB or BSA-B trunk, per month, will be assumed based on the following:

- A single monthly surrogate of assumed minutes per two-way line/trunk per month shall be 3080 for FGA or BSA-B FCO/ONAL lines and 9000 for FGA or BSA-A lines or FGB trunks. For FGA or BSA-A lines, the terminating assumed usage will be 47% of the two-way surrogate and the originating assumed usage will be 53% of the two-way surrogate. For FGB or BSA-B trunks, the terminating assumed usage will be one half of the two-way surrogate and the originating will be one half of the two-way surrogate.
- When measurement capabilities do not exist for a one way FGA or BSA-A line or FGB or BSA-B trunk, a single monthly surrogate of assumed minutes per one way line/trunk per month shall apply as described above.

WN U-16
ZiPLY Fiber

Original Sheet 270

FACILITIES FOR INTRASTATE ACCESS

4. SWITCHED ACCESS (Cont'd)

4.5 Rate and Charge Regulations (Cont'd)

4.5.2 Rate Regulations (Cont'd)

(I) Measuring Access Minutes (Cont'd)

(3) Usage Measurement Not Available For FGA, FGB, BSA-A and BSA-B
(Cont'd)

- When measurement capabilities do not exist in one direction for a two-way line (e.g., recording for terminating only) the number of access minutes per line, per month will be the assumed surrogate for a two-way line or the recorded usage for the single direction, whichever is greater.
- In the event of measurement equipment failure, minutes of use will be determined as follows:

For the initial month of service, FGA or BSA-A or FGB or BSA-B minutes will be assumed as indicated above unless actual usage recorded prior to the failure is greater than the assumed usage.

For subsequent months, the greater of 1) actual usage recorded prior to the failure, or 2) the average of the three month current months' usage (or less if three months are not available) will be used.

(4) FGC and BSA-C Usage Measurement

For originating calls over FGC or BSA-C, usage measurement begins when the originating FGC or BSA-C first point of switching receives answer supervision from the customer designated location, indicating the called party has answered. However, for billing purposes usage begins at the time that the originating end user's call is delivered by the Telephone Company, and acknowledged as received by the customer's facilities connected with the originating central office.

FACILITIES FOR INTRASTATE ACCESS

4. SWITCHED ACCESS (Cont'd)4.5 Rate and Charge Regulations (Cont'd)4.5.2 Rate Regulations (Cont'd)(I) Measuring Access Minutes (Cont'd)(4) FGC and BSA-C Usage Measurement (Cont'd)

For originating calls over FGC or BSA-C, measured access minutes are converted into chargeable access minutes using the following equation and factor:

Originating Minutes = Conversation minutes + (factor x quantity of completed calls).

Factor = non-conversation minutes per completed call + [(non-conversation minutes per incompleting call) x (1 - completion ratio)] divided by completion ratio]

The measurement of originating call usage over FGC or BSA-C ends when the FGC or BSA-C first point of switching receives disconnect supervision from either the end office switch, indicating the originating end user has disconnected, or the CDL, whichever is recognized first by the first point of switching.

For terminating calls over FGC or BSA-C to services other than SAC Access or Directory Assistance, terminating FGC or BSA-C usage is not directly measured at the first point of switching, but is derived from originating usage, excluding usage from calls to SAC Access or Directory Assistance Services.

Terminating call usage over FGC or BSA-C, other than SAC Access and Directory Assistance, is derived from originating usage as follows:

Terminating Minutes = Originating conversation minutes x In/Out ratio.

In/Out Ratio = Relationship between originating (i.e. Out) and terminating (i.e. In) conversation minutes

For terminating calls over FGC or BSA-C to SAC Access or Directory Assistance Services, usage measurement begins when the FGC or BSA-C first point of switching receives answer supervision from the end office switch, indicating the terminating SAC Access Service end user has answered, or from the Directory Assistance Service location, indicating the Directory Assistance operator has answered.

The measurement of terminating call usage over FGC or BSA-C to SAC Access or Directory Assistance Services ends when the FGC or BSA-C first point of switching receives an on-hook supervisory signal from the end office switch, indicating the terminating SAC Access Service end user has disconnected, or from the Directory Assistance location, indicating the Directory Assistance operator has disconnected, or from the CDL, whichever occurs first.

WN U-16
ZiPLY Fiber

Original Sheet 272

FACILITIES FOR INTRASTATE ACCESS

4. SWITCHED ACCESS (Cont'd)

4.5 Rate and Charge Regulations (Cont'd)

4.5.2 Rate Regulations (Cont'd)

(I) Measuring Access Minutes (Cont'd)

(5) FGD and BSA-D Usage Measurement

For originating calls over FGD or BSA-D with multifrequency (MF) signaling, usage measurement begins when the FGD or BSA-D first point of switching receives the first wink supervisory signal forwarded from the CDL.

For originating calls over FGD or BSA-D with SS7 Out of Band Signaling, usage measurement for direct trunks begins when the FGD or BSA-D first point of switching sends an Initial Address Message. Usage measurement for tandem trunks begins when the FGD or BSA-D first point of switching receives an Exit Message.

The measurement of originating call usage over FGD or BSA-D with MF signaling ends when the FGD or BSA-D first point of switching receives disconnect supervision from either the end office switch, indicating the originating end user has disconnected, or the CDL, whichever is recognized first by the first point of switching.

The measurement of originating call usage over FGD or BSA-D with SS7 Out of Band Signaling ends when a Release Message is sent or received by the originating end user's end office, whichever occurs first.

For terminating calls over FGD or BSA-D with MF signaling, or with FGD or BSA-D Out of Band Signaling, usage measurement begins when the FGD or BSA-D first point of switching receives answer supervision from the end office switch, indicating the terminating end user has answered.

The measurement of terminating call usage over FGD or BSA-D with MF signaling ends when the FGD or BSA-D first point of switching receives disconnect supervision from either the end office switch, indicating the terminating end user has disconnected, or the CDL, whichever is recognized first by the first point of switching.

The measurement of terminating call usage over FGD or BSA-D with SS7 Out of Band Signaling ends when the FGD or BSA-D first point of switching receives or sends a Release Message, whichever occurs first.

WN U-16
ZiPLY Fiber

Original Sheet 273

FACILITIES FOR INTRASTATE ACCESS

4. SWITCHED ACCESS (Cont'd)

4.5 Rate and Charge Regulations (Cont'd)

4.5.2 Rate Regulations (Cont'd)

(I) Measuring Access Minutes (Cont'd)

(6) SAC Access Service Usage Measurement

SAC Access Service usage measurement shall be in accordance with the regulations described for FGC, FGD, BSA-C and BSA-D. Specifically, for usage originating from end offices not equipped with equal access capabilities, access minutes shall be measured in the same manner in which FGC or BSA-C access minutes are measured. For usage originating from end offices equipped with equal access capabilities, access minutes shall be measured in the same manner in which FGD or BSA-D access minutes are measured.

(J) FGD and BSA-D Switched Access Service With 950-XXXX

When a customer orders FGD or BSA-D Switched Access Service with 950-XXXX Access, as described in 4.2.5(S), to be included with the installation of new FGD or BSA-D switched access facilities, appropriate Switched Access Installation Charges and Switched Access Ordering Charges will apply for the installation of the new FGD or BSA-D switched access facilities.

When a customer orders FGD or BSA-D Switched Access Service with 950-XXXX Access to be added to an existing FGD or BSA-D switched access service, only the Switched Access Ordering Charges and the Design Change Charge will apply for the additions of this optional end office service arrangement.

4.5.3 Switched Access Zone Density Rate Plan

(A) Description of the Plan

- (1) The Zone Density Rate Plan is a methodology used for rating Switched Access Transport services. The Zone Density Plan assigns every Serving Wire Center (SWC) or Telephone Company access tandem to one of three zones. The Serving Wire Center, CLLI Codes and zones are listed in Section 19. Rate zone assignments are established based upon the traffic density of each wire center and are divided into three categories. Zone 1 SWCs have the highest density of services, Zone 2 SWCs have intermediate density of services and Zone 3 SWCs have the lowest density of services.
-

WN U-16
Zipty Fiber

Original Sheet 274

FACILITIES FOR INTRASTATE ACCESS

4. SWITCHED ACCESS (Cont'd)

4.5 Rate and Charge Regulations (Cont'd)

4.5.3 Switched Access Zone Density Rate Plan (Cont'd)

(A) Description of the Plan (Cont'd)

(1) (Cont'd)

The Zone Density Rate Plan applies to the following Switched Access Services:

- Carrier Common Line Service
- DS1 to Voice Multiplexing Arrangement
- DS3 to DS1 Multiplexing Arrangement
- Direct-Trunked Transport Facility
- Direct-Trunked Transport Termination
- Entrance Facility
- Tandem-Switched Transport Facility
- Tandem-Switched Transport Termination
- Tandem Switching

(a) The Entrance Facility is rated according to the zone of the serving wire center of the CDL.

(b) Distance Sensitive Transport charges:

- When the distance is measured between wire centers within the same rate zone, the distance sensitive transport will be rated according to the zone of the serving wire center of the CDL and the end office.
- When the distance is measured between wire centers in two different zones, the distance sensitive transport will be rated at the higher zone rate.

WN U-16
ZiPLY Fiber

Original Sheet 275

FACILITIES FOR INTRASTATE ACCESS

4. SWITCHED ACCESS (Cont'd)

4.5 Rate and Charge Regulations (Cont'd)

4.5.3 Switched Access Zone Density Rate Plan (Cont'd)

(A) Description of the Plan (Cont'd)

(1) (Cont'd)

(c) Transport Terminations will be rated according to the zone of the end office and the zone of the SWC of the CDL (or other rating point, e.g., Hub Wire Center). Each termination is separately rated based on the zone of the terminating location.

(d) Tandem Switching will be rated according to the zone of the Telephone Company access tandem office.

(e) Multiplexing arrangements will be rated according to the zone of the Hub wire center.

(2) The Zone Density Rate Plan is not applicable to End Office Switching, Interconnection, Carrier Common Line, Information Surcharge and Nonrecurring charges.

4.5.4 Application of Rates for FGA or BSA-A Extension Service

FGA or BSA-A is available with extensions (i.e., additional terminations of the service at different buildings in the same LATA). FGA or BSA-A extensions are provided and charged for as Special Access. The rate elements which apply are Special Transport (from the extension bridging point to the wire center serving the CDL), and Special Access Lines. All appropriate monthly rates and nonrecurring charges are in 5.7.

FACILITIES FOR INTRASTATE ACCESS

4. SWITCHED ACCESS (Cont'd)4.5 Rate and Charge Regulations (Cont'd)4.5.5 Switched Access DS1 Optional Payment Plan (OPP)General

Customers subscribing to the Switched DS1 OPP will not be assessed a nonrecurring charge (NRC) for initial installations of a First System Entrance Facility. For each Additional System DS1 Entrance Facility, the NRC in 4.6.2(H) will apply.

The terms and conditions specified herein are applicable to DS1 Entrance Facility services.

Only the Entrance Facility rate element is available under an OPP. All other associated rate elements or additional features are available under the standard month-to-month tariffed rates and regulations.

DS1 OPP Entrance Facility rates will not be greater than standard month-to-month entrance facility rates.

Term commitment periods of one year, three year and five year are available to all customers at the applicable rates in 4.6.2(K).

The customer must designate the term commitment period for the OPP on the subscription form.

When a customer elects to subscribe to an OPP arrangement for switched DS1 service, only the First System DS1 Entrance Facility rate element is subject to the OPP terms and conditions.

For ordering and rating of DS1 OPP services under an OPP subscription, a First System DS1 OPP Entrance Facility charge must be assessed at a CDL before any Additional System DS1 Entrance facilities can be assessed.

Under an OPP arrangement, the same customer can order additional DS1 services at any time subsequent to establishing a First System DS1 OPP.

The installation charge associated with DS1 services subscribed to an OPP are specified in 4.5.2(A)(3)(d)(2).

Discount Factors

Discount factors are percentage discounts applied to the DS1 Month-to-Month First System rate as shown in 4.6.2(H) to derive the applicable tariff rate for each term commitment period. The resulting discounted tariff rate will be calculated to the same number of decimal places as the undiscounted tariff rate.

FACILITIES FOR INTRASTATE ACCESS

4. SWITCHED ACCESS (Cont'd)4.5 Rate and Charge Regulations (Cont'd)4.5.5 Switched Access DS1 Optional Payment Plan (OPP) (Cont'd)Discount Factors (Cont'd)

Customers will be billed Entrance Facility charges for each term commitment period based on the tariffed discounted rate as shown in 4.6.2(K). The billable portion (the complement of the discount factor) of the non-discounted tariffed rate used to derive the discounted rate will also be displayed on the customer's bill.

Furthermore, a rate cap will apply under a plan where no shortfalls, reassessment of savings or early termination occurs. The rate cap is generally equal to the undiscounted rate at the beginning of the plan. If price increases occur and the discounted rate as shown in 4.6.2(K) exceeds the rate cap, the rate cap is charged in place of the discounted rate.

Annual Commitment Levels

To obtain the price discount, the customer agrees to purchase a specified level of First System DS1 OPP Entrance Facilities over a committed period of time. The commitment is expressed as a monthly quantity of units associated with the various rate elements. To meet its commitment, a customer must meet both an Average Monthly Billed Quantity (AMQ) and an In-service (the quantity in service during the last month of each annual assessment period) Billed Quantity level (ISQ).

Start and Stop Date

The Term commitment period is initiated at the beginning of a month (start date) and is completed, in one year increments, at the end of a pre-determined month (stop date). During this time period, the discount is applied to the base rate.

Anniversary Dates

Anniversary dates occur between the start and stop dates. For a one year plan, the anniversary date is the end date of the plan. For multi-year plans, anniversary dates occur at the end of each twelve-month period of the plan.

Changes in Length of an OPP Period

Prior to completion of the selected OPP term commitment, the customer may elect to convert to a new OPP period of the same or different length, subject to the following conditions:

- No credit toward the new term commitment period will be given for payments made under the original OPP arrangement.
 - Nonrecurring charges will not be reapplied for existing service(s).
-

WN U-16
ZiPLY Fiber

Original Sheet 278

FACILITIES FOR INTRASTATE ACCESS

4. SWITCHED ACCESS (Cont'd)

4.5 Rate and Charge Regulations (Cont'd)

4.5.5 Switched Access DS1 Optional Payment Plan (OPP) (Cont'd)

Ordering and Renewal Options

A customer must request the OPP in writing via subscription; however, an ASR form will not be necessary.

A customer may, at any time during the OPP, renew the plan based upon current market and tariff conditions, provided the new plan's expiration date occurs no sooner than the current OPP expiration date and the new plan is at the same or larger commitment.

Unless advance written notification is received from the customer, an expired OPP will be renewed for one year at current tariff terms.

Written notice of discontinuance must be given by the customer at least thirty days prior to actual discontinuance. Monthly recurring charges under the plan will apply for a period of thirty days from the date the Company receives discontinuance notification or until the end of the month following receipt of discontinuance notification, whichever period is longer.

When a customer converts from existing month-to-month DS1 service(s) to an OPP arrangement, no service or billing interruption will occur. If no other changes to the service(s) are ordered, no charges will apply.

Upgrade to Higher Speed Service

Customers may elect to upgrade service(s) to a higher speed through aggregation of existing services or service additions during an OPP period subject to the following conditions:

- The upgraded service must be subscribed to a term commitment of equal or greater length.
- The upgraded service will be subject to all appropriate nonrecurring charges.
- Termination liability charges will not apply as long as the upgraded service remains connected at the same point of termination(s) or meets the requirements specified in 4.5.2(A)(3)(K(2)).
- If the upgrade involves establishing a multiplexing arrangement, termination liability charges will not apply if the hub wire center is the same one associated with the customer-designated location.

WN U-16
ZiPLY Fiber

Original Sheet 279

FACILITIES FOR INTRASTATE ACCESS

4. SWITCHED ACCESS (Cont'd)

4.5 Rate and Charge Regulations (Cont'd)

4.5.5 Switched Access DS1 Optional Payment Plan (OPP) (Cont'd)

Shortfall and Early Termination

When a DS1 service is discontinued prior to the end of the term commitment period or the number of DS1 Entrance Facilities under the plan falls below 100% of the commitment level, the customer may be liable for shortfall, reassessment of savings and early termination charges.

Determination:

Each plan will be reviewed at the end of the third month following plan anniversary or early termination date to determine if commitment levels were achieved. AMQ and ISQ shortfall monthly units will be assessed and applied independently of each other.

Assessment:

Shortfall calculation - A comparison of actual AMQ to committed AMQ and actual ISQ to committed ISQ is made. The difference is multiplied by a shortfall factor of 20 percent. The resultant shortfall units are rated at the current tariff rate.

Reassessment of savings calculation - A comparison of actual AMQ to committed AMQ and actual ISQ to committed ISQ is made. For a one year plan, actual units are re-rated at the current tariff rate. The difference between the actual units rated at the current tariff rate and at the discounted rate represents the reassessment of savings.

For a multi-year plan terminating after the first year, actual units are re-rated using the discount factor for a plan of that length. For example, a five year plan terminating in the third year would re-rate all actual units using the discount rate for a three year plan.

WN U-16
ZiPLY Fiber

Original Sheet 280

FACILITIES FOR INTRASTATE ACCESS

4. SWITCHED ACCESS (Cont'd)

4.5 Rate and Charge Regulations (Cont'd)

4.5.5 Switched Access DS1 Optional Payment Plan (OPP) (Cont'd)

Shortfall and Early Termination (Cont'd)

Early Termination Calculation only applies during the first six months of a multi-year term commitment plan. 100% of the average monthly commitment units for six months (penalty months) are rated at the current tariff rate.

The following describes the application of shortfall charges and early termination charges:

- If actual units are less than the commitment, the shortfall penalty applies.
- If termination occurs during the first six months of the plan, the shortfall penalty, reassessment of savings and early termination charges apply.
- If termination occurs after six months but before one year, the shortfall and reassessment of savings penalties apply.
- If termination occurs after one year but before a plan's stop date, actual units for all previous months are re-rated using the discount rate for a plan of that length. In addition, the shortfall unit charge for the year in which the termination occurs also applies.

Termination Without Liability

Should the recurring charges for a customer's DS1 service increase from the original recurring charges during the term commitment period, the customer may, at their option, terminate the DS1 service without penalty or liability.

FACILITIES FOR INTRASTATE ACCESS

4. SWITCHED ACCESS (Cont'd)4.5 Rate and Charge Regulations (Cont'd)4.5.6 Switched Access DS1 Term Payment PlanDescription

The Switched DS1 Term Payment Plan (TPP) allows customers discounts for DS1 Entrance Facilities (EF) in exchange for term and minimum quantity commitments. This service is available on a single state level only. TPP is offered for 1, 2, 3 or 5 year term commitment periods. All TPP DS1 Entrance Facilities (at the state level) will be billed the same rate, depending on the length of term selected by the customer.

Discount Factors

Discount factors are percentage discounts applied to the DS1 Month-to-Month First System rate as shown in 4.6.2(L) to derive the applicable tariff rate for each term commitment period. The resulting discounted tariff rate will be calculated to the same number of decimal places as the undiscounted tariff rate.

Customers will be billed Entrance Facility charges for each term commitment period based on the tariffed discounted rate as shown in 4.6.2(L). The billable portion (the complement of the discount factor) of the non-discounted tariffed rate used to derive the discounted rate will also be displayed on the customer's bill.

Furthermore, a rate cap will apply under a plan where no shortfalls, reassessment of savings or early termination occurs. The rate cap is generally equal to the undiscounted rate at the beginning of the plan. If price increases occur and the discounted rate as shown in 4.6.2(M) exceeds the rate cap, the rate cap is charged in place of the discounted rate.

Annual Commitment Levels

To obtain the price discount, the customer agrees to purchase a minimum level of DS1 Entrance Facilities over a committed period of time. The commitment is expressed as a monthly quantity of units associated with the various rate elements. To meet its commitment, a customer must meet both an Average Monthly Billed Quantity (AMQ) and an In-service (the quantity in service during the last month of each annual assessment period) Billed Quantity level (ISQ).

Start and Stop Date

The Term commitment period is initiated at the beginning of a month (start date) and is completed, in one year increments, at the end of a pre-determined month (stop date). During this time period, the discount is applied to the base rate.

Anniversary Dates

Anniversary dates occur between the start and stop dates. For a one year plan, the anniversary date is the end date of the plan. For multi-year plans, anniversary dates occur at the end of each twelve-month period of the plan.

FACILITIES FOR INTRASTATE ACCESS

4. SWITCHED ACCESS (Cont'd)

4.5 Rate and Charge Regulations (Cont'd)

4.5.6 Switched Access DS1 Term Payment Plan (Cont'd)

Rate Changes

Decreases in the TPP monthly recurring Entrance Facility rates will be passed on to subscribers.

Minimum Commitment Levels

To initiate a TPP, a minimum commitment of 30 DS1 Entrance Facilities is required. The commitment levels will be met if the customer has met the minimum number of AMQ and ISQ units in service during the annual review.

Changes to Commitment Levels

Written notice must be submitted by the customer to change the commitment level of DS1 Entrance Facilities. Resubscription will be required if as a result of increasing or decreasing the commitment level, service is changed from a TPP to a standard month-to-month or OPP arrangement. Only one TPP arrangement will be allowed per customer for each term period.

TPP Plan Subscription

When the customer elects to subscribe to a TPP they must specify, in writing, the enrollment date (which will be the anniversary date) and the commitment level.

To convert existing DS1 OPP Entrance Facilities to a TPP, no termination liabilities will be assessed if the TPP period selected is equal to or longer in length than the time remaining for the existing DS1 OPP. If the TPP period is shorter in length than the time remaining on the existing DS1 OPP, the change to TPP constitutes a disconnect of the DS1 OPP and termination liabilities will apply.

WN U-16
ZiPLY Fiber

Original Sheet 283

FACILITIES FOR INTRASTATE ACCESS

4. SWITCHED ACCESS (Cont'd)

4.5 Rate and Charge Regulations (Cont'd)

4.5.6 Switched Access DS1 Term Payment Plan (Cont'd)

Shortfall and Early Termination

When a DS1 TPP service is discontinued prior to the end of the term commitment period or the number of DS1 Entrance Facilities under the plan falls below 100% of the commitment level, the customer may be liable for shortfall, reassessment of savings and early termination charges.

Determination:

Each plan will be reviewed at the end of the third month following plan anniversary or early termination date to determine if commitment levels were achieved. AMQ and ISQ shortfall monthly units will be assessed and applied independently of each other.

Assessment:

Shortfall calculation - A comparison of actual AMQ to committed AMQ and actual to committed ISQ is made. The difference is multiplied by a shortfall factor of 20 percent. The resultant shortfall monthly units are rated at the current tariff rate.

Reassessment of savings calculation - A comparison of actual AMQ to committed AMQ and actual ISQ to committed ISQ is made. For a one year plan, actual units are re-rated at the current tariff rate. The difference between the actual units rated at the current tariff rate and at the discounted rate represents the reassessment of savings.

For a multi-year plan terminating after the first year, actual units are re-rated using the discount factor for a plan of that length. For example, a five year plan terminating in the third year would re-rate all actual units using the discount rate for a three year plan.

FACILITIES FOR INTRASTATE ACCESS

4. SWITCHED ACCESS (Cont'd)4.5 Rate and Charge Regulations (Cont'd)4.5.6 Switched Access DS1 Term Payment Plan (Cont'd)Shortfall and Early Termination (Cont'd)

Early Termination Calculation (applicable during the first six months of a multi-year term commitment plan only). 100% of the average monthly commitment units for six months (penalty months) are rated at the current tariff rate.

The following describes the application of shortfall charges and early termination charges:

- If actual units are less than the commitment, the shortfall penalty apply.
- If termination occurs during the first six months of the plan, the shortfall penalty, reassessment of savings and early termination charges apply.
- If termination occurs after six months but before one year, the shortfall and reassessment of savings penalties apply.
- If termination occurs after one year but before a plan's stop date, actual units for all previous months are re-rated using the discount rate for a plan of that length. In addition, the shortfall unit charge for the year in which the termination occurs also applies.

TPP Conditions

After subscribing to a TPP, the customer may add or delete DS1 Entrance Facilities rated at the specified term commitment rate at any time during the plan.

A customer may subscribe to only one plan for each term period within a given state.

TPP Nonrecurring Charge

Customers subscribing to a TPP will be assessed a nonrecurring charge per Entrance Facility except in the following conditions:

- when converting standard month-to-month DS1 Entrance Facilities to a TPP.
 - when converting DS1 OPPs to a TPP at plan enrollment.
 - when converting DS1 OPPs to a TPP at a time other than plan enrollment if the DS1 OPP has been billed for at least six months.
-

WN U-16
ZiPLY Fiber

Original Sheet 285

FACILITIES FOR INTRASTATE ACCESS

4. SWITCHED ACCESS (Cont'd)

4.5 Rate and Charge Regulations (Cont'd)

4.5.6 Switched Access DS1 Term Payment Plan (Cont'd)

Changes in Length of an TPP Period

Prior to the expiration of a TPP period, the customer may elect to convert to a new TPP period of the same or different length, subject to the following conditions:

- no credit will be given for the new term commitment period for payments made under the original TPP arrangement.
- NRCs will not be reapplied for existing service(s).
- if the new TPP period is shorter in length than the time remaining under the existing TPP, the change to the new TPP period constitutes a disconnect of service and termination liability charges will apply.
- the rates for the new period will be the rates currently in effect at the time of the change.

Ordering and Renewal Options

A customer must request a TPP in writing via subscription; however, an ASR form will not be required to subscribe.

A customer may, at any time during the TPP, renew the plan based upon current market and tariff conditions, provided the new plan's expiration date occurs no sooner than the current TPP expiration date and the new plan is at the same or larger commitment. At the expiration of a TPP period, the customer may select a new TPP period, convert to a month-to-month payment plan or select an OPP arrangement.

FACILITIES FOR INTRASTATE ACCESS

4. SWITCHED ACCESS (Cont'd)

4.5 Rate and Charge Regulations (Cont'd)

4.5.6 Switched Access DS1 Term Payment Plan (Cont'd)

Ordering and Renewal Options (Cont'd)

Unless advance written notification is received from the customer, an expired TPP will be renewed for one year at current tariff terms.

Should the recurring charges for a customer's TPP service increase from the original recurring charges during the term commitment period, the customer may, at their option, terminate the TPP service without penalty or liability.

Written notice for discontinuance of a TPP arrangement must be given by the customer at least thirty days prior to actual discontinuance. Monthly recurring charges under the plan will apply for a period of thirty days from the date the Company receives discontinuance notification or until the end of the month following receipt of discontinuance notification, whichever period is longer.

Upgrade to Higher Speed Service

The customer may upgrade service to a higher speed during a TPP period. The upgraded service will be subject to all appropriate NRCs.

If both of the following conditions exist, the commitment level will be decreased by the number of TPP DS1 Entrance Facilities that are upgraded to a higher speed service:

- the customer must notify the Telephone Company in writing in addition to issuing an ASR for the higher speed service.
- the higher speed term commitment period must be equal to or longer in length than the time remaining under the TPP.

4.5.7 Switched Access DS3 Term Payment Plan

Option 1: Individual DS3s. This option requires a commitment of Individual DS3s between a CDL and its serving wire center. Entrance Facility rates for Individual System DS3s vary depending on whether the interface provided is electrical or optical. Pricing for this option is per DS3 and will vary by length of term. All Individual System DS3 Entrance Facilities are non-distance sensitive.

WN U-16
ZiPLY Fiber

Original Sheet 287

FACILITIES FOR INTRASTATE ACCESS

4. SWITCHED ACCESS (Cont'd)

4.5 Rate and Charge Regulations (Cont'd)

4.5.7 Switched Access DS3 Term Payment Plan (Cont'd)

Option 2: Minimum Quantity DS3s. This option allows customers discounts for DS3 Entrance Facilities in exchange for term and minimum quantity commitments. This option is available on a single state level only and requires a minimum quantity of six DS3 Entrance Facilities throughout the state. DS3 Entrance Facilities can be aggregated from any location(s) in the state and the aggregation is not dependent on the type of interface. Discount rates vary depending on whether the interface provided is electrical or optical. All Minimum Quantity DS3 Entrance Facilities are non-distance sensitive.

Price discounts vary between the Individual and Minimum Quantity DS3s when term commitments are made. For the Minimum Quantity option, the "commitment level" is determined by the number of DS3 facilities. For example, a shared use DS3 will count as a full DS3 toward the commitment level. All Entrance Facilities subscribed to a term commitment plan between a Customer Designated Location and its serving wire center must be subscribed to the same term commitment plan. Term commitments may vary between switched and special access services on shared use facilities.

Term Commitment Periods

Individual DS3s are offered under a month-to-month arrangement and under four term commitment periods, each with a different rate level. Minimum Quantity DS3s are offered under four term commitment periods, each with different rate levels. The term commitment periods are 1, 3, 5 and 7 years. For each DS3 Entrance Facility option, the customer must specify the term commitment period and the number of DS3s being committed to at the time the service is subscribed.

The customer may convert from the Individual Month-to-Month arrangement or may upgrade to a new plan with a longer term commitment period at any time, without penalty or application of nonrecurring charges, to obtain the lower monthly recurring rates associated with a longer term commitment period. For purposes of plan administration, conversion from a month-to-month arrangement or to a longer term commitment will be treated as a termination of service, without liability, and the establishment of new service.

Conversion from the minimum quantity option to the individual option is considered termination of service, with liability, and the establishment of new service.

FACILITIES FOR INTRASTATE ACCESS

4. SWITCHED ACCESS (Cont'd)4.5 Rate and Charge Regulations (Cont'd)4.5.7 Switched Access DS3 Term Payment Plan (Cont'd)Discount Factors

Discount factors are percentage discounts applied to the DS3 Individual Month-to-Month rate as shown in 4.6.2 to derive the applicable tariff rate for each term commitment period. The resulting discounted tariff rate will be calculated to the same number of decimal places as the undiscounted tariff rate.

Customers will be billed Entrance Facility charges for each term commitment period based on the tariffed discounted rate as shown in 4.6.2(L) or 4.6.2(M) depending on the option selected. The billable portion (the complement of the discount factor) of the non-discounted tariffed rate used to derive the discounted rate will also be displayed on the customer's bill.

Furthermore, a rate cap will apply under a plan where no shortfalls, reassessment of savings or early termination occurs. The rate cap is the maximum rate a customer can be billed during the life of the plan. The rate cap is determined by the first non-discounted rate billed for the MRC and is set concurrent with the establishment of all new plans.

Annual Commitments Levels

To obtain the price discount, the customer agrees to purchase a specified level of DS3 Entrance Facilities over a committed period of time. The commitment is expressed as a monthly quantity of units associated with the various rate elements. To meet its commitment, a customer must meet both an Average Monthly Billed Quantity (AMQ) and an In-service (the quantity in service during the last month of each annual assessment period) Billed Quantity level (ISQ).

To obtain Minimum Quantity DS3 discounts, the customer must specify a commitment equal to or greater than six DS3 Entrance Facilities within a state and a term period. The commitment levels will be met if the customer has met the minimum number of AMQ and ISQ units during the annual review. Only one Minimum Quantity DS3 arrangement will be allowed per customer for each state. The customer may upgrade to a longer term at any time, without penalty, by resubscribing to a new term commitment plan. Conversion to a shorter term commitment is considered to be a termination of the plan, with penalty, and subscription to another plan.

FACILITIES FOR INTRASTATE ACCESS

4. SWITCHED ACCESS (Cont'd)4.5 Rate and Charge Regulations (Cont'd)4.5.7 Switched Access DS3 Term Payment Plan (Cont'd)Start and Stop Date

The Term commitment period is initiated at the beginning of a month (start date) and is completed, in one year increments, at the end of a pre-determined month (stop date). During this time period, the discount is applied to the base rate (the month-to-month, non-discounted rate).

Anniversary Dates

Anniversary dates occur between the start and stop dates. For a one-year plan, the anniversary date is the end date of the plan. For multi-year plans, anniversary dates occur at the end of each twelve-month period of the plan.

Expiration of a Term Commitment Period

Unless advance written notice is received from the customer, an expired term commitment plan will be renewed for one year at current tariff terms.

Termination Without Liability

Should the recurring charges for a customer's DS3 service increase from the original recurring charges during the term commitment period, the customer may, at their option, terminate the DS3 service without penalty or liability.

Shortfall and Early Termination

When a DS3 service is discontinued prior to the end of the term commitment period or the number of DS3 Entrance Facilities under the plan falls below 100% of the commitment level, the customer may be liable for shortfall, reassessment of savings and early termination charges.

Determination:

Each plan will be reviewed at the end of the third month following plan anniversary or early termination date to determine if commitment levels were achieved. AMQ and ISQ shortfall monthly units will be assessed and applied independently of each other.

Assessment:

Shortfall calculation - A comparison of actual AMQ to committed AMQ and actual ISQ to committed to ISQ is made. The difference is multiplied by a shortfall factor of 20 percent. The resultant shortfall units are rated at the current tariff rate.

WN U-16
ZiPLY Fiber

Original Sheet 290

FACILITIES FOR INTRASTATE ACCESS

4. SWITCHED ACCESS (Cont'd)

4.5 Rate and Charge Regulations (Cont'd)

4.5.7 Switched Access DS3 Term Payment Plan (Cont'd)

Assessment: (Cont'd)

Reassessment of savings calculation - A comparison of actual AMQ to committed AMQ and actual ISQ to committed ISQ is made. For a one-year plan, actual units are re-rated at the current tariff rate. The difference between the actual units rated at the current tariff rate and at the discounted rate represents the reassessment of savings.

For a multi-year plan terminating after the first year, actual units are re-rated using the discount factor for a plan of that length. For example, a five-year plan terminating in the third year would re-rate all actual units using the discount rate for a three year plan.

Early Termination Calculation only applies during the first six months of a multi-year term commitment plan. 100% of the average monthly commitment units for six months (penalty months) are rated at the current tariff rate for the service terminated.

The following describes the application of shortfall charges and early termination charges:

- If actual units are less than the commitment, the shortfall penalty will apply.
- If termination occurs during the first six months of the plan, the shortfall penalty, reassessment of savings and early termination charges apply.
- If termination occurs after six months but before one year, the shortfall and reassessment of savings penalties apply.
- If termination occurs after one year but before a plan's stop date, actual units for all previous months are re-rated using the discount rate for a plan of that length. In addition, the shortfall unit charge for the year in which the termination occurs also applies.

WN U-16
ZiPLY Fiber

Original Sheet 291

FACILITIES FOR INTRASTATE ACCESS

4. SWITCHED ACCESS (Cont'd)

4.5 Rate and Charge Regulations (Cont'd)

4.5.7 Switched Access DS3 Term Payment Plan (Cont'd)

Notice of Discontinuance

Written notice of discontinuance must be given by the customer at least thirty days prior to actual discontinuance. Monthly recurring charges under the plan will apply for a period of thirty days from the date the Company receives discontinuance notification or until the end of the month following receipt of discontinuance notification, whichever period is longer.

Upgrade from Individual to Minimum Quantity DS3s

Should the customer elect to upgrade their Individual DS3 service to a Minimum Quantity DS3 plan, the termination liabilities for DS3 services to be upgraded will not apply as long as the services remain connected at the same point of termination(s) or if applicable, meets the requirements specified in 4.5.2(A)(3)(K). No credit will be given for the time in service associated with the previous DS3 service(s). A new term commitment period equal to or longer than the longest remaining term commitment period of the upgraded service(s) will be required for the upgrade. For example, upgrading an Individual DS3 during the end of the second year of a five year commitment will require subscription to a new three year (or longer) term commitment to a Minimum Quantity Plan.

NRCs for DS3 Entrance Facilities will only apply for additional DS3 Systems required to achieve minimum commitment levels (i.e., NRCs will not apply for existing Individual System DS3s that are upgraded to the Minimum Quantity plan.

FACILITIES FOR INTRASTATE ACCESS

4. SWITCHED ACCESS (Cont'd)4.5 Rate and Charge Regulations (Cont'd)4.5.8 Shared Use Analog and Digital High Capacity Services

Monthly charges for a DS1 or DS3 high capacity shared used facility will be apportioned between Switched and Special Access based on the relative proportion of channels used for switched and special access in the following manner.

If the facility is ordered as Special Access, rating as Special Access will continue until such time as a portion of the available capacity is used to provide Switched Access service. As individual channels are activated for Switched Access, monthly charges will be apportioned between Switched and Special Access based on the number of channels used for Switched Access and the number of remaining channels on the Special Access facility according to the following formula:

- The total shared use charge is equal to the Monthly Switched Access Charge times the number of channels used for Switched Access divided by 24 for DS1 or 672 for DS3 plus the monthly Special Access Charge times the number of channels remaining for Special Access divided by 24 for DS1 or 672 for DS3.

If the facility is ordered as Switched Access, rating as Switched Access will continue until such time as a portion of the available capacity is used to provide Special Access service. As individual channels are activated for Special Access, monthly charges will be apportioned between Switched and Special Access based on the number of channels used for Special Access and the number of remaining channels on the Switched Access Facility according to the following formula:

- The total shared use charge is equal to the Monthly Special Access Charge times the number of channels used for Special Access divided by 24 for DS1 or 672 for DS3 plus the monthly Switched Access Charge times the number of channels remaining for Switched Access divided by 24 for DS1 or 672 for DS3.

The monthly Switched and Special Access rate used will be the appropriate rate (Special Access SAL, Transport, Multiplexer and/or Cross Connect Arrangement and Switched Access Entrance Facility, Direct-Trunked Transport, Multiplexer and/or Cross Connect Arrangement) for the underlying shared use facility. Customers will be permitted to subscribe to term commitments that differ between Switched and Special Access services on shared use facilities. Upon expiration of the term commitment for Switched or Special Access services, the Telephone Company will continue to bill the customer as described in 4.5.8. If the customer chooses to discontinue service at the expiration of a term commitment period, billing will be based on the facility charges for the remaining service. Discontinuance prior to the expiration of term commitment periods will be subject to charges described in 4.5.6, 4.5.7 and 4.5.8.

FACILITIES FOR INTRASTATE ACCESS

4. SWITCHED ACCESS (Cont'd)4.5 Rate and Charge Regulations (Cont'd)4.5.9 Basic Service Elements (BSEs)

Recurring rates and charges for Basic Service Elements (BSEs) in 4.2.21 are applied on a premium or nonpremium basis as discussed in 4.5.2(H)(1). The Switched Access Ordering Charge will not apply when a customer orders BSEs in conjunction with the establishment of a Basic Serving Arrangement (BSA) or the conversion of a feature group to a BSA. The Switched Access Ordering Charge will apply to changes to or additions of BSEs associated with an established BSA. The application of monthly recurring charges or usage rates to BSEs are as follows.

(A) Alternate Traffic Routing - BSE

Premium and nonpremium nonrecurring charges in 4.6.3 apply per trunk group equipped.

(B) Automatic Number Identification (ANI) - BSE

Rates in 4.6.3 apply per ANI attempt.

(C) User Transfer - BSE

Monthly recurring charges in 4.6.3 apply per line arranged.

(D) Hunt Group Arrangement - BSE

Premium and nonpremium monthly recurring charges in 4.6.3 apply per line equipped.

(E) Queuing - BSE

Premium and nonpremium monthly recurring charges in 4.6.3 apply per group equipped.

WN U-16
Zipty Fiber

Original Sheet 294

FACILITIES FOR INTRASTATE ACCESS

4. SWITCHED ACCESS (Cont'd)

4.5 Rate and Charge Regulations (Cont'd)

4.5.9 Basic Service Elements (BSEs) (Cont'd)

(F) Uniform Call Distribution - BSE

Premium and nonpremium monthly recurring charges in 4.6.3 apply per line equipped.

(G) Simplified Message Desk Interface (SMDI) - BSE

Premium and nonpremium monthly recurring charges in 4.6.3 apply per line equipped.

(H) Remote Call Forwarding - BSE

Charges found in the General and Local Exchange Service Catalog, Section 4.

(I) Direct Inward Dialing (DID) - BSE

Charges found in the General and Local Exchange Service Catalog, Section 8.

(J) Billed Number Screening (BNS) - BSE

Charges found in the General and Local Exchange Service Catalog, Section 8.

WN U-16
Zipty Fiber

Original Sheet 295
95

FACILITIES FOR INTRASTATE ACCESS

4. SWITCHED ACCESS (Cont'd)

4.6 Rates and Charges

4.6.1 Nonrecurring Charges

	<u>Charge</u>
(A) <u>Switched Access Service Ordering Charges</u>	
Switched Access Ordering Charge, per ASR	
OCN 4324	\$100.00
OCN 4423	74.46
Design Change Charge, per ASR per occurrence	
OCN 4324	38.04
OCN 4423	38.04
(B) <u>500 NXX Translation Charge – OCN 4324, OCN 4424</u>	
First NXX, Per ASR/Per End Office	21.00
Each Additional NXX, Per ASR/ Per End Office	11.00
(C) <u>Network Blocking Charge – OCN 4324, OCN 4424</u>	
Applies to FGB, FGC, FGD, BSA-B, BSA-C, BSA-D and SAC Access Service, Per Call	.016
(D) <u>FGA and BSA-A Optional Toll Blocking – OCN 4324, OCN 4424</u>	
Per FGA or BSA-A Line	5.32

Note: See Section 15 to determine OCN by Wire Center.

Issued: July 29, 2020
Issued by Zipty Fiber
By Jessica Epley, Regulatory & External Affairs Director

Effective: July 31, 2020

WN U-16
Zipty Fiber

Original Sheet 296

FACILITIES FOR INTRASTATE ACCESS

4. SWITCHED ACCESS (Cont'd)

4.6 Rates and Charges (Cont'd)

4.6.2 Switched Transport

	<u>OCN 4324</u>	<u>Rate</u> <u>OCN 4423</u>
(A) <u>Tandem-Switched Transport - Facility</u> per access minute, per airline mile		
Zone 1 and No Zones		
Terminating – End Office	\$.0	\$.0
Terminating – 3 rd Party	.0000200	.0000200
Originating	.0000290	.0000290
Zone 2		
Terminating - End Office	.0	
Terminating – 3 rd Party	.0000200	
Originating	.0000290	
Zone 3		
Terminating - End Office	.0	
Terminating – 3 rd party	.0000200	
Originating	.0000290	
(B) <u>Tandem-Switched Transport - Termination</u> per access minute, per termination		
Zone 1 and No Zones		
Terminating - End Office	.0	.0
Terminating – 3 rd Party	.0	.0
Originating	.0001690	.0001690
Zone 2		
Terminating - End Office	.0	
Terminating – 3 rd Party	.0	.0
Originating	.0001690	
Zone 3		
Terminating - End Office	.0	
Terminating – 3 rd Party	.0	.0
Originating	.0001690	
(C) <u>Tandem Switching Rate</u> per access minute		
Zone 1 and No Zones		
Terminating - End Office	.0	.0
Terminating – 3 rd Party	.00163702	.00178399
Originating	.0015000	.0015000
Zone 2		
Terminating - End Office	.0	
Terminating – 3 rd Party	.00163702	
Originating	.0015000	
Zone 3		
Terminating - End Office	.0	
Terminating – 3 rd Party	.00163702	
Originating	.0015000	

Note: See Section 15 to determine OCN by Wire Center.

WN U-16
ZiPLY Fiber

Original Sheet 297

FACILITIES FOR INTRASTATE ACCESS

4. SWITCHED ACCESS (Cont'd)

4.6 Rates and Charges (Cont'd)

4.6.2 Switched Transport (Cont'd)

		<u>Rate</u>
(D)	<u>Direct-Trunked Transport - Voiceband</u>	
	Direct-Trunked Transport Facility Voiceband per airline mile, per month	
	OCN 4324	\$3.00
	OCN 4423	3.00
(E)	<u>Direct-Trunked Transport - DS1</u>	
	Direct-Trunked Transport - Facility DS1 per airline mile, per month	
	OCN 4324 Zone 1	4.37
	OCN 4324 Zone 2	4.37
	OCN 4324 Zone 3	4.37
	OCN 4423 No Zone	3.00
	Direct-Trunked Transport – Termination DS1	
	OCN 4324 Zone 1	20.11
	OCN 4324 Zone 2	25.41
	OCN 4324 Zone 3	28.84
	OCN 4423 No Zone	37.50
(F)	<u>Direct-Trunked Transport - DS3</u>	
	Direct-Trunked Transport – Facility DS3	
	OCN 4324 Zone 1	35.00
	OCN 4324 Zone 2	35.00
	OCN 4324 Zone 3	35.00
	OCN 4423 No Zone	35.00
	Direct-Trunked Transport – Termination DS3	
	OCN 4324 Zone 1	300.00
	OCN 4324 Zone 2	300.00
	OCN 4324 Zone 3	300.00
	OCN 4423 No Zone	300.00

Note: See Section 15 to determine OCN by Wire Center.

Issued: July 29, 2020
Issued by ZiPLY Fiber
By Jessica Epley, Regulatory & External Affairs Director

Effective: July 31, 2020

WN U-16
ZiPLY Fiber

Original Sheet 298

FACILITIES FOR INTRASTATE ACCESS

4. SWITCHED ACCESS (Cont'd)

4.6 Rates and Charges (Cont'd)

4.6.2 Switched Transport (Cont'd)

		<u>Service Installation</u>	<u>Monthly Rate</u>
(G)	<u>Entrance Facility - 2-Wire and 4-Wire Voiceband</u>		
	Entrance Facility - 2-Wire		
	OCN 4324	\$200.00	\$29.15
	OCN 4423	160.39	26.51
	Entrance Facility - 4-Wire		
	OCN 4324	200.00	45.47
	OCN 4323	160.39	34.50
(H)	<u>Entrance Facility - DS1</u>		
	First System		
	OCN 4324	450.00	215.00
	OCN 4324	450.00	230.00
	OCN 4324	450.00	250.00
	OCN 4423	450.00	244.19
	Each Additional System		
	OCN 4324	450.00	140.30
	OCN 4324	450.00	140.30
	OCN 4324	450.00	250.00
	OCN 4423	115.62	140.30

Note: See Section 15 to determine OCN by Wire Center.

Issued: July 29, 2020
Issued by ZiPLY Fiber
By Jessica Epley, Regulatory & External Affairs Director

Effective: July 31, 2020

WN U-16
ZiPLY Fiber

Original Sheet 299
99

FACILITIES FOR INTRASTATE ACCESS

4. SWITCHED ACCESS (Cont'd)

4.6 Rates and Charges (Cont'd)

4.6.2 Switched Transport (Cont'd)

		<u>Service Installation</u>	<u>Monthly Rate</u>
(I)	<u>Entrance Facility - DS3 Electrical Interface</u>		
	OCN 4324 Zone 1	\$750.00	\$810.00
	OCN 4324 Zone 2	750.00	937.50
	OCN 4324 Zone 3	750.00	1,125.00
	OCN 4423 No Zone	800.43	1,131.74
	<u>Entrance Facility - DS3 Optical Interface</u>		
	OCN 4324 Zone 1	1,000.00	1,100.00
	OCN 4324 Zone 2	1,000.00	1,186.00
	OCN 4324 Zone 3	1,000.00	1,500.00
	OCN 4423 No Zone	675.00	957.50
(J)	<u>Multiplexing</u>		
	<u>DS1 to Voice</u>		
	OCN 4324 Zone 1	800.00	190.00
	OCN 4324 Zone 2	800.00	190.00
	OCN 4324 Zone 3	800.00	190.00
	OCN 4423 No Zone	800.00	190.00
	<u>DS3 to DS1</u>		
	OCN 4324 Zone 1	450.00	410.97
	OCN 4324 Zone 2	450.00	410.97
	OCN 4324 Zone 3	450.00	410.97
	OCN 4423 No Zone	400.22	410.97

Note: See Section 15 to determine OCN by Wire Center.

WN U-16
Zipty Fiber

Original Sheet 300

FACILITIES FOR INTRASTATE ACCESS

4. SWITCHED ACCESS (Cont'd)

4.6 Rates and Charges (Cont'd)

4.6.2 Switched Transport (Cont'd)

Monthly
Rate

(K) Entrance Facility - DS1 Optional Payment
Plan (Discounted Rate)

First System Only ¹

One Year Plan	Zone 1	\$237.50
	Zone 2	237.50
	Zone 3	237.50
Three Year Plan	Zone 1	212.50
	Zone 2	212.50
	Zone 3	212.50
Five Year Plan	Zone 1	187.50
	Zone 2	187.50
	Zone 3	187.50

¹ A nonrecurring charge will not be assessed for the First System Entrance Facility.

WN U-16
ZiPLY Fiber

Original Sheet 301

FACILITIES FOR INTRASTATE ACCESS

4. SWITCHED ACCESS (Cont'd)

4.6 Rates and Charges (Cont'd)

4.6.2 Switched Transport (Cont'd)

		<u>Nonrecurring Charge</u>	<u>Monthly Rate</u>
(L)	<u>Entrance Facility - DS1 - Term Payment Plan (Discounted Rate)</u>		
	One Year Plan		
	Zone 1	\$450.00	\$187.50
	Zone 2	450.00	187.50
	Zone 3	450.00	187.50
	Two Year Plan		
	Zone 1	450.00	175.00
	Zone 2	450.00	175.00
	Zone 3	450.00	175.00
	Three Year Plan		
	Zone 1	450.00	162.50
	Zone 2	450.00	162.50
	Zone 3	450.00	162.50
	Five Year Plan		
	Zone 1	450.00	150.00
	Zone 2	450.00	150.00
	Zone 3	450.00	150.00

WN U-16
ZiPLY Fiber

Original Sheet 302

FACILITIES FOR INTRASTATE ACCESS

4. SWITCHED ACCESS (Cont'd)

4.6 Rates and Charges (Cont'd)

4.6.2 Switched Transport (Cont'd)

		<u>Nonrecurring Charge</u>	<u>Monthly Rate</u>
(M)	<u>Entrance Facility - DS3 – Term Payment Plan (Discounted Rate)</u>		
	Individual DS3 - Electrical Interface		
	One Year Plan		
	Zone 1	\$800.43	\$1,080.00
	Zone 2	800.43	1,080.00
	Zone 3	800.43	1,080.00
	Three Year Plan		
	Zone 1	800.43	1,020.00
	Zone 2	800.43	1,020.00
	Zone 3	800.43	1,020.00
	Five Year Plan		
	Zone 1	800.43	900.00
	Zone 2	800.43	900.00
	Zone 3	800.43	900.00
	Seven Year Plan		
	Zone 1	800.43	840.00
	Zone 2	800.43	840.00
	Zone 3	800.43	840.00

WN U-16
ZiPLY Fiber

Original Sheet 303

FACILITIES FOR INTRASTATE ACCESS

4. SWITCHED ACCESS (Cont'd)

4.6 Rates and Charges (Cont'd)

4.6.2 Switched Transport (Cont'd)

(M) Entrance Facility - DS3 – Term
Payment Plan (Discounted Rate) (Cont'd)

Individual DS3 -
Electrical Interface

		<u>Nonrecurring Charge</u>	<u>Monthly Rate</u>
One Year Plan	Zone 1	\$720.39	\$810.00
	Zone 2	720.39	810.00
	Zone 3	720.39	810.00
Three Year Plan	Zone 1	720.39	765.00
	Zone 2	720.39	765.00
	Zone 3	720.39	765.00
Five Year Plan	Zone 1	720.39	675.00
	Zone 2	720.39	675.00
	Zone 3	720.39	675.00
Seven Year Plan	Zone 1	720.39	630.00
	Zone 2	720.39	630.00
	Zone 3	720.39	630.00

WN U-16
Zipty Fiber

Original Sheet 304

FACILITIES FOR INTRASTATE ACCESS

4. SWITCHED ACCESS (Cont'd)

4.6 Rates and Charges (Cont'd)

4.6.2 Switched Transport (Cont'd)

(M) Entrance Facility - DS3 - Term
Payment Plan (Discounted Rate) (Cont'd)

Minimum Quantity -
Electrical Interface

		<u>Nonrecurring Charge</u>	<u>Monthly Rate</u>
One Year Plan	Zone 1	\$800.00	\$1,020.00
	Zone 2	800.00	1,020.00
	Zone 3	800.00	1,020.00
Three Year Plan	Zone 1	800.00	960.00
	Zone 2	800.00	960.00
	Zone 3	800.00	960.00
Five Year Plan	Zone 1	800.00	840.00
	Zone 2	800.00	840.00
	Zone 3	800.00	840.00
Seven Year Plan	Zone 1	800.00	780.00
	Zone 2	800.00	780.00
	Zone 3	800.00	780.00

WN U-16
ZiPLY Fiber

Original Sheet 305

FACILITIES FOR INTRASTATE ACCESS

4. SWITCHED ACCESS (Cont'd)

4.6 Rates and Charges (Cont'd)

4.6.2 Switched Transport (Cont'd)

(M) Entrance Facility - DS3 - Term Payment Plan (Discounted Rate) (Cont'd)

Minimum Quantity -
Optical Interface

		<u>Nonrecurring Charge</u>	<u>Monthly Rate</u>
One Year Plan	Zone 1	\$700.00	\$765.00
	Zone 2	700.00	765.00
	Zone 3	700.00	765.00
Three Year Plan	Zone 1	700.00	720.00
	Zone 2	700.00	720.00
	Zone 3	700.00	720.00
Five Year Plan	Zone 1	700.00	630.00
	Zone 2	700.00	630.00
	Zone 3	700.00	630.00
Seven Year Plan	Zone 1	700.00	585.00
	Zone 2	700.00	585.00
	Zone 3	700.00	585.00

WN U-16
ZiPLY Fiber

Original Sheet 306

FACILITIES FOR INTRASTATE ACCESS

4. SWITCHED ACCESS (Cont'd)

4.6 Rates and Charges (Cont'd)

4.6.2 Switched Transport (Cont'd)

	<u>Rate</u>
(N) <u>Interconnection Rate, per access minute</u>	
Premium	
Terminating	.00
Originating	.00
Nonpremium	
Terminating	.00
Originating	.00

WN U-16
Zipty Fiber

Original Sheet 307

FACILITIES FOR INTRASTATE ACCESS

4. SWITCHED ACCESS (Cont'd)

4.6 Rates and Charges (Cont'd)

4.6.3 End Office Services

		<u>Rate</u>	
		<u>OCN 4324</u>	<u>OCN 4423</u>
(A) <u>End Office Switching - Bundled (EOSB)</u>			
For all Feature Group types			
Per Access Minute			
Premium:	Terminating	\$.00000000	\$.00000000
	Originating	.0158172	.0158172
Nonpremium:	Terminating	.00000000	.00000000
	Originating	.0071177	.0071177
(B) <u>End Office Switching - Unbundled (EOSU)</u>			
For all Feature Group types			
Per Access Minute			
Premium:	Terminating	\$.00000000	\$.00000000
	Originating	.0158197	.0158197
Nonpremium:	Terminating	.00000000	.00000000
	Originating	.0071177	.0071177
		<u>Nonrecurring Charge</u>	
(C) <u>Alternate Routing – BSE – OCN 4324, OCN 4423</u>			
Per Trunk Group Equipped			
	Premium	\$75.02	
	Nonpremium	37.51	

Note: See Section 15 to determine OCN by Wire Center.

WN U-16
Zipty Fiber

Original Sheet 308

FACILITIES FOR INTRASTATE ACCESS

4. SWITCHED ACCESS (Cont'd)

4.6 Rates and Charges (Cont'd)

4.6.3 End Office Services (Cont'd)

Rate

(D)	<u>Automatic Number Identification (ANI) – BSE – OCN 4324, OCN 4423</u>		
	Per ANI Attempt		\$.0001500
(E)	<u>User Transfer – BSE - OCN 4324, OCN 4423</u>		
	Per Line/Trunk Arranged		1.50
(F)	<u>Queuing – BSE - OCN 4324, OCN 4423</u>		
	Per Group Equipped		15.00
(G)	<u>Uniform Call Distribution – BSE - OCN 4324, OCN 4423</u>		
	Per Line Equipped		
	Premium		5.13
	Nonpremium		2.57
(H)	<u>Simplified Message Desk Interface (SMDI) – BSE - OCN 4324, OCN 4423</u>		
	Per DNAL		
	Premium		223.19
	Nonpremium		100.44
(I)	<u>Local Switching Trunk Port</u>	<u>OCN 4324</u>	<u>OCN 4423</u>
	Dedicated Trunk Port – DS1	.0	.0
	Dedicated Trunk Port – Analog	.0	.0
	Shared Trunk Port – Terminating	.0	.0
	Shared Trunk Port – Originating	.00000000	.00000000

Note: See Section 15 to determine OCN by Wire Center.

Issued: July 29, 2020
 Issued by Zipty Fiber
 By Jessica Epley, Regulatory & External Affairs Director

Effective: July 31, 2020

WN U-16
ZiPLY Fiber

Original Sheet 309

FACILITIES FOR INTRASTATE ACCESS

4. SWITCHED ACCESS (Cont'd)

4.6 Rate and Charges (Cont'd)

4.6.4	<u>Information Surcharge</u>	<u>Rate</u>	
	Per Access Minute		
	Premium:	Terminating	\$0.00
		Originating	0.00
	Nonpremium:	Terminating	0.00
		Originating	0.00
4.6.5	<u>IntraLATA Equal Access Recovery Charge</u>		
	Per Originating Access Minute		0.00
		<u>Nonrecurring Charge</u>	<u>Monthly Rate</u>
4.6.6	<u>Carrier Identification Parameter (CIP) – OCN 4324, OCN 4423</u>		
	CIP - Per CIP, per Trunk Group (NRC)		
	Access Tandem	\$1,120.00	
	End Office Direct	80.00	
	CIP - Per Trunk (MR)		\$0.46

Note: See Section 15 to determine OCN by Wire Center.

Issued: July 29, 2020
 Issued by ZiPLY Fiber
 By Jessica Epley, Regulatory & External Affairs Director

Effective: July 31, 2020

FACILITIES FOR INTRASTATE ACCESS

SECTION 5 TABLE OF CONTENTS

5. <u>SPECIAL ACCESS</u>	<u>Sheet No.</u>
5.1 <u>General</u>	318
5.1.1 Rate Elements	318
(A) Special Transport	320
(B) Special Access Line (SAL)	321
(C) Supplemental Features	323
(D) Multiplexing Arrangements	323
(E) Special Transport Termination	323
(1) DS1, DS1C and DS3 Service	323
(2) Fractional T1 Service (FT1)	323
5.1.2 Special Access Configurations	324
(A) Two-point Service	324
(B) Multipoint Service	326
5.1.3 Special Facilities Routing	328
5.1.4 Design Layout Report	328
5.1.5 Acceptance Testing	329
5.1.6 Ordering Conditions	330
(A) Determination of Jurisdiction of Mixed Use Special Access Service	330
(B) Special Access Jurisdictional Verification	330
5.2 <u>Description of Special Access</u>	331
5.2.1 Voiceband	332
(A) Two-Wire Voiceband Facility	332
(B) Four-Wire Voiceband Facility	332
5.2.2 Program Audio	332
(A) 200 to 3500 Hz	333
(B) 100 to 5000 Hz	333
(C) 50 to 8000 Hz	333
(D) 50 to 15000 Hz	333

WN U-16
Zipty Fiber

Original Sheet 311

FACILITIES FOR INTRASTATE ACCESS

SECTION 5 TABLE OF CONTENTS

5.	<u>SPECIAL ACCESS</u> (Cont'd)	<u>Sheet No.</u>
5.2	<u>Description of Special Access</u> (Cont'd)	
5.2.3	Videoband	334
5.2.4	Wideband Analog	335
5.2.5	Wideband Data Service	336
5.2.6	High Capacity Digital	336
5.2.7	Digital Data Service	338
5.2.8	Miscellaneous Special Access Services	338
5.3	<u>Description of Terminating Options</u>	338
5.3.1	Narrowband	339
	(A) 0 to 75 Baud Type 1	339
	(B) 0 to 75 Baud Type 2	339
	(C) 0 to 150 Baud	339
5.3.2	Voice Grade	340
	(A) Two-Wire Voice Grade, Non-Data, Without Signaling	340
	(B) Four-Wire Voice Grade, Non-Data, Without Signaling	340
	(C) Voice Grade Data Termination	340
	(D) Two-Wire Voice Grade Station Connecting Facility Termination .	341
	(E) Four-Wire Voice Grade Station Connecting Facility Termination.	341
	(F) Two-Wire Station Connecting Facility Termination for the Open End of an Off Premises PBX Extension	341
	(G) Dial Repeating Tie Trunk Termination	341
5.3.3	Program Audio	342
	(A) 200 to 3500 Hz	342
	(B) 100 to 5000 Hz, 50 to 8000 Hz, and 50 to 15000 Hz	342

FACILITIES FOR INTRASTATE ACCESS

SECTION 5 TABLE OF CONTENTS

5. <u>SPECIAL ACCESS</u>	<u>Sheet No.</u>
5.3 <u>Description of Terminating Options (Cont'd)</u>	
5.3.4 Videoband	343
5.3.5 Wideband Data Service	343
5.3.6 High Capacity Digital	344
(A) High Capacity DS1.....	344
(B) High Capacity DS1C.....	344
(C) Fractional T1 Service.....	344
(D) FiberConnect Service	344
(E) High Capacity Digital DS3.....	345
(F) High Capacity Digital DS3C	345
5.3.7 Digital Data Service	345
5.4 <u>Description of Supplemental Features</u>	346
5.4.1 Bridging	346
(A) Multipoint Data Bridging.....	346
(B) Voice Conference Bridging	346
(C) Alarm Distribution Bridging.....	346
(D) Program Audio Bridging	346
(E) Dataphone Select-A-Station Bridging.....	347
(F) DDS Bridging.....	347
5.4.2 Conditioning Arrangements - Data	347
(A) Type C.....	348
(B) Type DA	348
5.4.3 Conditioning - Program Audio	348
(A) Stereo Conditioning	348
(B) Zero Loss	348
5.4.4 Signaling Arrangements.....	349
5.4.5 Echo Control.....	351
(A) Echo Suppression.....	351
(B) Echo Cancellor	352

WN U-16
ZiPLY Fiber

Original Sheet 313

FACILITIES FOR INTRASTATE ACCESS

SECTION 5 TABLE OF CONTENTS (Cont'd)

5. <u>SPECIAL ACCESS</u> (Cont'd)	<u>Sheet No.</u>
5.4 <u>Description of Supplemental Features</u> (Cont'd)	
5.4.6 Improved Return Loss.....	352
5.4.7 Voiceband Facility Switching Arrangement.....	352
5.4.8 Automatic Protection Switch.....	353
5.4.9 Improved Termination Option.....	353
5.4.10 Improved Equal Level Echo Path Loss Option – ELEPL-2.....	354
5.5 <u>Description of Multiplexing Arrangements</u>	354
5.5.1 Voice to Narrowband.....	355
5.5.2 Group to Voice.....	355
5.5.3 Supergroup to Group.....	355
5.5.4 Mastergroup to Supergroup.....	355
5.5.5 DS1 to Voice.....	356
5.5.6 DS1C to Voice.....	356
5.5.7 DS1C to DS1.....	357
5.5.8 DS3 to DS1.....	357
5.5.9 DS3C to DS1.....	357
5.5.10 Group to DS1.....	358
5.5.11 Digital Data Carrier Multiplexer.....	358
5.5.12 Digital Data Substrate Multiplexer.....	358
5.6 <u>Rate Regulations</u>	359
5.6.1 Types of Rates and Charges.....	359
(A) Monthly Rates.....	359
(B) Daily Rates.....	359
(C) Hourly Rates.....	360
(D) Nonrecurring Charges.....	360
(1) Special Access Ordering Charges.....	361
(a) Initial Ordering Charge - Special Access.....	361
(b) Subsequent Ordering Charge - Special Access.....	361

WN U-16
ZiPLY Fiber

Original Sheet 314

FACILITIES FOR INTRASTATE ACCESS

SECTION 5 TABLE OF CONTENTS (Cont'd)

5.	<u>SPECIAL ACCESS</u> (Cont'd)	<u>Sheet No.</u>
5.6	<u>Rate Regulations</u> (Cont'd)	
5.6.1	Types of Rates and Charges (Cont'd)	
	(D) Nonrecurring Charges (Cont'd)	
	(2) Service Installation Charge	362
	(3) Design Change Charge	362
	(4) Installation of Supplemental Features and Multiplexing Arrangements	363
	(5) Installation of DS1, FiberConnect, FT1, DDS and DS3 Special Access Lines	364
	(6) Installation of Temporary Voiceband Service	365
	(7) Service Rearrangements	365
5.6.2	Minimum Periods	369
5.6.3	Mileage Measurement	369
5.6.4	Moves	370
	(A) Same CDL	370
	(B) Different CDL	371
5.6.5	Rates and Charges on an Individual Case Basis	372
5.6.6	Hub Wire Centers	373
5.6.7	Shared Use Analog and Digital High Capacity Services	375
5.6.8	Temporary Videoband Service	376
	(A) Use of Nonpermanent Facilities for Temporary Videoband Service	377
	(B) Joint Provisioning of Service	377

WN U-16
Zipty Fiber

Original Sheet 315

FACILITIES FOR INTRASTATE ACCESS

SECTION 5 TABLE OF CONTENTS (Cont'd)

5.	<u>SPECIAL ACCESS</u> (Cont'd)	<u>Sheet No.</u>
5.6	<u>Rate Regulations</u> (Cont'd)	
5.6.9	High Voltage Protection	378
	(A) Description	378
	(B) Provisioning	378
	(C) Claims and Demands for Damage	380
	(D) Network Outage	380
	(E) Compliance Statement	381
	(F) Rate Regulations	381
5.6.10	Metro Ethernet Special Transport	382
	(A) Description	382
	(B) Conversion of Existing DS1 Transport	382
	(C) Discontinuance of Service	382
	(D) Continuation of Service Off the Ring	383
	(E) Service Availability	383
5.6.11	DS3 High Capacity Service.....	384
	(A) DS3 Rate Structure	384
	(B) Minimum Service Period	386
	(C) Expiration of Minimum Service Period.....	386
	(D) Discontinuance Without Liability - DS3 Minimum Service Period....	386
	(E) Discontinuance With Liability - DS3 Minimum Service Period	386
	(F) Notification of Discontinuance.....	387
	(G) DS3 Multiplexer Cross Connect Arrangement	387

WN U-16
ZiPLY Fiber

Original Sheet 316

FACILITIES FOR INTRASTATE ACCESS

SECTION 5 TABLE OF CONTENTS (Cont'd)

5.	<u>SPECIAL ACCESS</u> (Cont'd)	<u>Sheet No.</u>
5.6	<u>Rate Regulations</u> (Cont'd)	
5.6.12	Optional Payment Plan (OPP) for FT1, FiberConnect and DDS	388
	(A) General.....	388
	(B) Changes in Length of OPP Period	389
	(C) Renewal Options.....	390
	(D) Notification of Discontinuance	390
	(E) Upgrade to Higher Speed Service	391
	(F) Termination Liability	391
	(G) OPP for DDS	391
5.6.13	Optional Payment Plan (OPP) for DS1	392
	(A) General.....	392
	(B) Conditions	393
	(C) Moves	393
	(D) Changes in Length of OPP Period	393
	(E) Renewal Options.....	394
	(F) Notification of Discontinuance	394
	(G) Upgrade to Higher Speed Service	394
	(H) Termination Liability	394
5.7	<u>Rates and Charges</u>	395
5.7.1	Special Access Ordering Charges	395
5.7.2	Voiceband Facilities	396
5.7.3	Program Audio (200-3500 Hz) Facilities	400
5.7.4	Program Audio (100-5000 Hz) Facilities	401
5.7.5	Program Audio (50-8000 Hz) Facilities	402

FACILITIES FOR INTRASTATE ACCESS

SECTION 5 TABLE OF CONTENTS (Cont'd)

5.	<u>SPECIAL ACCESS</u> (Cont'd)	<u>Sheet No.</u>
5.7	<u>Rates and Charges</u> (Cont'd)	
5.7.6	Program Audio (50-15000 Hz) Facilities.....	403
5.7.7	High Capacity Digital DS1 (1.544 Mbps) Facilities	404
	(A) Standard Arrangements.....	404
	(B) Optional Payment Plan	405
	(C) Optional Arrangements.....	405
5.7.8	High Capacity Digital DS1C (3.152 Mbps) Facilities	406
5.7.9	High Capacity Digital FiberConnect (6.312 Mbps)Facilities	407
5.7.10	High Capacity Digital Fractional T1 Facilities	409
	(A) Standard Arrangement	409
	(B) FT1 Optional Payment Plan	410
5.7.11	High Capacity DS3 (44.736 Mbps) Facilities - Three System	413
5.7.12	High Capacity DS3 (44.736 Mbps) Facilities - Individual System	415
5.7.13	High Capacity DS3 (44.736 Mbps) Facilities - Special Transport	416
5.7.14	High Capacity DS3 (44.736 Mbps) Facilities - DS3 Multiplexer Cross Connect Arrangement	416
5.7.15	Digital Data Service Facilities	417
5.7.16	Multiplexing Arrangements	420
5.7.17	High Voltage Protection	420
5.7.18	Digital Data Multiplexer.....	421
5.8	<u>Miscellaneous Special Access Service</u>	422
5.8.1	Clear Channel Capability	422
	(A) Description of Service.....	422
	(B) Rates	422

WN U-16
ZiPLY Fiber

Original Sheet 318

FACILITIES FOR INTRASTATE ACCESS

5. SPECIAL ACCESS

5.1 General

Special Access provides a transmission path to connect CDLs¹ within a LATA for Intrastate Telecommunications. Special Access provided to a customer may be connected directly to customer facilities, through Telephone Company Hub Wire Centers where bridging or multiplexing functions are performed, and/or may be connected to access facilities of another telephone company or companies in the joint provision of Special Access Service.

Special Access can be provided in either analog or digital format. Analog formats are differentiated by spectrum and bandwidth. Digital formats are differentiated by bit rate. The specific types of Special Access (e.g., Voiceband, Wideband Data Service) provided are described in 5.2.

5.1.1 Rate Elements

With the exception of Temporary Videoband Service, there are five basic rate elements which apply to Special Access Service:

- Special Transport [described in 5.1.1(A)]
- Special Transport Termination [described in 5.1.1(E)]
- Special Access Line [described in 5.1.1(B)]
- Supplemental Features (described in 5.1.1.(c))
- Multiplexing Arrangements (described in 5.1.1(D))

¹ Telephone Company Centrex CO-like switches are considered to be CDLs for the purposes of this tariff.

WN U-16
ZiPLY Fiber

Original Sheet 319

FACILITIES FOR INTRASTATE ACCESS

5. SPECIAL ACCESS (Cont'd)

5.1 General (Cont'd)

5.1.1 Rate Elements (Cont'd)

The following is a list of ZiPLY Fiber Telephone Companies Tariff No. 3 Open Network Architecture (ONA) Special Access Basic Service Elements (BSEs) which provide a cross-reference to the generic ONA product names.

<u>Generic Name</u>	<u>Telephone Company Name</u>
Access to Clear Channel Transmission	Clear Channel Capability
Automatic Protection Switching	Automatic Protection Switching
Bridging	Bridging
Conditioning	Conditioning
Data Over Voice (DOV) Service	DOV Connect
Secondary Channel Capability	Digital Data Service - Secondary Channel
Multiplexing - Digital 2000	Multiplexing Arrangements

The DS1 Special Access Line provided under this tariff will not be billed when provisioned with Integrated Services Digital Network-Primary Rate Interface (ISDN-PRI) Service that uses alternate higher capacity digital facilities for the loop transport. Higher capacity digital facilities include Optical Networking when the optical node is at the same location as well as DS3 Special Access Lines provided under the ZiPLY Fiber FCC Tariff 2, intrastate tariffs and individual case basis (ICB) contracts. A DS1 Special Access Line provisioned in the same serving wire center at which the customer obtains ISDN-PRI Service will be transmitted with B8ZS Clear Channel Capability per Technical Reference Publication GR-342, Issue 1.

Note: Telephone Company Centrex CO-like switches are considered to be CDLs for the purposes of this tariff.

Issued: July 29, 2020
 Issued by ZiPLY Fiber
 By Jessica Epley, Regulatory & External Affairs Director

Effective: July 31, 2020

WN U-16
ZiPLY Fiber

Original

FACILITIES FOR INTRASTATE ACCESS

5. SPECIAL ACCESS (Cont'd)

5.1 General (Cont'd)

5.1.1 Rate Elements (Cont'd)

(A) Special Transport

- (1) The Special Transport rate element provides for the transmission facilities between the serving wire centers associated with two CDLs, between a serving wire center associated with an end user's CDL and a WATS Serving Office, between a serving wire center associated with a CDL and a Telephone Company Hub Wire Center or between two Telephone Company Hub Wire Centers.

The Special Transport rate element is distance sensitive, except for Metro Ethernet, and varies with type of capability (i.e., analog or digital) and type of facility (e.g., Voiceband, Wideband Data Service, etc.). Special Transport may be provided by more than one telephone company. The method of calculating applicable airline miles for rating purposes for Special Access is specified in 2.7.

Metro Ethernet Transport provides flat rate non-distance sensitive transport for Special Access DS1 bandwidth on fiber optic rings. The rate element associated with Metro Ethernet is a monthly recurring charge as specified in L.5.7.7(c). Metro Ethernet can only be ordered with a Telephone Company access service.

- (2) Special Transport may be used with Switched Access for the purpose of provisioning Originating Only, Terminating Only or Combined Originating/Terminating Access as specified in 4.2.5(U). Special Transport employed in this manner provides the FIA for the closed end of the services, between the wire center serving the end user's CDL where the WATS Serving Office functions are not available and the WATS Serving Office.

When the necessary WATS Serving Office functions are not provided at the wire center which serves the end user's CDL, the Telephone Company will designate the wire center where the WATS Serving functions are available.

- (3) For Fractional T1 (FT1) service, Special Transport must be ordered as Fractional Special Transport in the same grouping (N x 56 Kbps or N x 64 Kbps where N = 2, 4, or 6) as the associated FT1 SALs. Fractional T1 is limited to those services so equipped and in service as of September 3, 1996.
-

Issued: July 29, 2020
Issued by ZiPLY Fiber
By Jessica Epley, Regulatory & External Affairs Director

Effective: July 31, 2020

FACILITIES FOR INTRASTATE ACCESS

5. SPECIAL ACCESS (Cont'd)5.1 General (Cont'd)5.1.1 Rate Elements (Cont'd)(B) Special Access Line (SAL)

- (1) A Special Access Line provides the transmission facilities to a CDL or the facilities between a CDL and the serving wire center. This rate element varies by type of capability (i.e., analog or digital) and type of facility (e.g., Voiceband, Wideband Data Service, etc.).

When a Voiceband Special Access service is ordered to be terminated at a customer's designated Interexchange Carrier's all-digital CDL which requires a minimum digital interface level of 1.544 Mbps, the Telephone Company will provide the required interface and assess the customer a Voiceband SAL, for the facility between the all-digital CDL and its serving wire center. All other appropriate charges apply in addition to the Voiceband SAL.

SAL rates for DS3 offerings vary with the level of capacity, number of services and whether the interface provided is electrical or optical.

Installation of DS1/DS3 SALs is in 5.6.1(D)(5). The applicable rates are the nonrecurring charge and monthly rate per DS1/DS3 installed.

The selection of a Terminating Option, as defined in 5.3, is required for terminating the network portion of a Special Access Line at a CDL. Terminating Options provide a clearly delineated interface which facilitates the design, isolation and testing of the Special Access. For DS3 Special Access, the customer may specify either an electrical or optical interface as described in 3.1.1(F). Optical interface is available on an ICB.

One Special Access Line charge applies per CDL at which the facility is terminated. This charge will apply even if the CDL and the serving wire center are co-located in a Telephone Company building. The Special Access Line charge used with a Switching Interface, as in (2) below, is applicable only for the transmission facilities between the end user's CDL and the serving wire center of that location.

- (2) A Special Access Line may be provided with FGA, FGB, FGC, FGD, BSA-A, BSA-B, BSA-C and BSA-D Switched Access Services for the purpose of Originating Only, Terminating Only or Combined Originating and Terminating Access as described in 4.2.1 and 4.2.2. A Switching Interface is required for the provision of this service as described in 4.2.5(U). The Special Access Line provides the closed end of the dedicated facilities between and end user's CDL and its serving wire center. This serving wire center may or may not be a WATS Serving Office. In those instances when the serving wire center is not a WATS Serving Office, Special Transport is applicable as described in 5.1.1(B) to the nearest Telephone Company WATS Serving Office.
-

WN U-16
ZiPLY Fiber

Original Sheet 322

FACILITIES FOR INTRASTATE ACCESS

5. SPECIAL ACCESS (Cont'd)

5.1 General (Cont'd)

5.1.1 Rate Elements (Cont'd)

(B) Special Access Line (SAL) (Cont'd)

(2) (Cont'd)

The Switched Access used with the Special Access Line provides various standard switching functionalities and optional arrangements as described in 4.2.5(U).

All Special Access Lines used with a Switching Interface are:

- provided with dial pulse address signaling or Dual Tone Multifrequency (DTMF) address signaling and either loop start or ground start supervisory signaling. The type of signaling is the option of the customer.
- available as either a two-wire or four-wire Voiceband Special Access Service (i.e., 300-3000 Hz bandwidth). Each transmission path is provided with Standard Transmission Specifications as described in the Technical Interface Reference Manual.

All rules and regulations pertaining to Special Access are applicable to Special Access Lines used with a Switching Interface. Rates and charges for these services are found in 5.7.2 for two-wire and four-wire Voiceband Special Access Lines.

A customer may also order high capacity facilities from an end user's CDL to a Telephone Company Hub for the purpose of originating or terminating Special Access Lines used with a Switching Interface. High capacity to voice multiplexing will be required at the Hub. The customer will be required to submit an ASR for the high capacity facility and voice multiplexing. The customer will also be required to submit an ASR(s) for the individual Voiceband SALs specifying the channel facility assignment (CFA) for each service. This Hub may or may not be a WATS Serving Office. In those instances when the Hub is not a WATS Serving Office, Voiceband Special Transport is applicable as specified in 5.1.1(B), for each individual Special Access Line used with a Switching Interface to the Telephone Company designated WATS Serving Office.

WN U-16
ZiPLY Fiber

Original Sheet 323

FACILITIES FOR INTRASTATE ACCESS

5. SPECIAL ACCESS (Cont'd)

5.1 General (Cont'd)

5.1.1 Rate Elements (Cont'd)

(C) Supplemental Features

Supplemental Features may be added to a Special Access circuit to improve its quality or utility to meet specific communications requirements. These are not necessarily identifiable with specific facilities, but rather represent the end result in terms of performance characteristics which may be obtained. These characteristics may be obtained by using various combinations of facilities. Although the facilities necessary to perform a specified function may be installed at various locations along the path of the Special Access circuit, including the CDL, it will be provided for as a single rate element.

Examples of Supplemental Features that are available include, but are not limited to, bridging and conditioning. Each Supplemental Feature is described in 5.4, and rates are in 5.7.

(D) Multiplexing Arrangements

Multiplexing provides for arrangements to convert a single higher capacity or bandwidth circuit for bulk transport to several lower capacity or bandwidth circuits. Multiplexing is only available at a Telephone Company designated Hub Wire Center arranged for multiplexing. All types of multiplexing may not be available at each Hub Wire Center. Refer to Section 5.6.6 for a description of a Hub Wire Center. Descriptions for each type of multiplexing arrangement are provided in 5.5, and rates are specified in 5.7.

(E) Special Transport Termination

(1) DS1, DS1C and DS3 Service

The Special Transport Termination rate element as described in 5.7.8, 5.7.13 and 5.7.18, applies only to DS1, DS1C, Individual DS3 and System DS3 offerings and is in addition to the Special Transport Rate element. Special Transport Termination provides the equipment and arrangements necessary to terminate the Special Transport facility at a serving wire center. One Special Transport Termination charge applies for the termination of each end of a Special Transport facility for DS1, DS1C and DS3 (Individual and Systems) offerings.

(2) Fractional T1 Service (FT1)

For Fractional T1 Service, Special Transport Termination must be ordered as Fractional Special Transport Termination in the same grouping (N x 56 Kbps or N x 64 Kbps where N = 2, 4, or 6) as the associated FT1 SALs. Fractional T1 is limited to those services so equipped and in service as of September 3, 1996.

WN U-16
Zipty Fiber

Original Sheet 324

FACILITIES FOR INTRASTATE ACCESS

5. SPECIAL ACCESS (Cont'd)

5.1 General (Cont'd)

5.1.2 Special Access Configurations

There are two types of facility configurations over which Special Access Services are provided: two-point and multipoint.

(A) Two-point Service

A two-point configuration is a circuit which is provided to connect two CDLs, either directly connected or through a Hub Wire Center where multiplexing functions are performed, or a CDL and a WATS Serving Office.

All Special Access offerings may be provided as a two-point configuration.

FACILITIES FOR INTRASTATE ACCESS

5. SPECIAL ACCESS (Cont'd)

5.1 General (Cont'd)

5.1.2 Special Access Configurations (Cont'd)

(A) Two-Point Service (Cont'd)

With the exception of Temporary Videoband Service, applicable rate elements are:

- Special Access Lines
- Special Transport (when applicable)
- Special Transport Termination (when applicable)
- Supplemental Features (when applicable)
- Multiplexing Arrangements (when applicable)

The following diagram depicts a typical two-point service connecting two CDLs. The service is provided with the supplemental feature of Type C Conditioning:

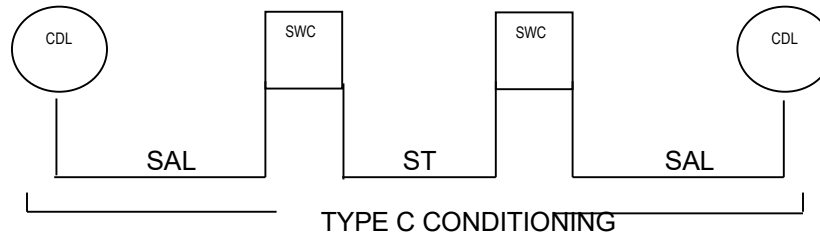

- SAL - Special Access Line
- ST - Special Transport
- SWC - Serving Wire Center
- CDL - Customer Designated Location

Applicable rate elements are:

- Special Access Line (2 applicable)
- Special Transport (per airline mile between SWCs)
- Supplemental Feature of Type C Conditioning (2 applicable)

WN U-16
ZiPLY Fiber

Original Sheet 326

FACILITIES FOR INTRASTATE ACCESS

5. SPECIAL ACCESS (Cont'd)

5.1 General (Cont'd)

5.1.2 Special Access Configurations (Cont'd)

(B) Multipoint Service

A multipoint configuration is a circuit that is provided to connect three or more CDLs through a Telephone Company Hub Wire Center.

Only Voiceband, Program Audio, and Digital Data Service facilities, where so designated, will be provided as multipoint configurations. There is no limitation on the number of mid-links, but the use of more than three mid-links in tandem may degrade the quality of the multipoint facilities. A mid-link is defined as the Special Transport facilities between Hub Wire Centers where the circuit is bridged and/or where circuit switching devices, such as loop transfer arrangement, are located.

Multipoint service is provided in the following manner:

- (1) Special Access Line per CDL to their respective serving wire centers.
- (2) Special Transport between serving wire centers associated with the CDLs and the Hub Wire Center.
- (3) Special Transport between Hub Wire Centers.
- (4) Supplemental Features: Bridging equipment for each bridging location and other Supplemental Features when applicable.

WN U-16
ZiPLY Fiber

Original Sheet 327

FACILITIES FOR INTRASTATE ACCESS

5. SPECIAL ACCESS (Cont'd)

5.1 General (Cont'd)

5.1.2 Special Access Configurations (Cont'd)

(B) Multipoint Service (Cont'd)

(5) Multiplexing Arrangements when applicable.

The following diagram depicts a multipoint service connecting four CDLs via two customer specified Hub Wire Centers:

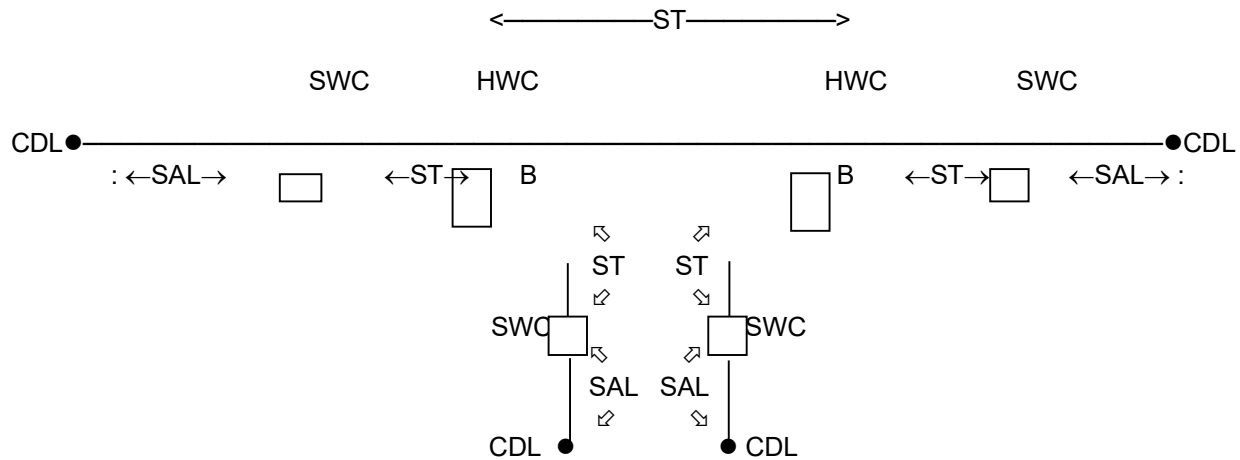

- SAL - Special Access Line
- ST - Special Transport
- SWC - Serving Wire Center
- CDL - Customer Designated Location
- HWC - Hub Wire Center
- B - Bridging

WN U-16
Zipty Fiber

Original Sheet 328

FACILITIES FOR INTRASTATE ACCESS

5. SPECIAL ACCESS (Cont'd)

5.1 General (Cont'd)

5.1.2 Special Access Configurations (Cont'd)

(B) Multipoint Service (Cont'd)

Applicable rate elements are:

- Special Access Lines (4 applicable)
- Special Transport (5 segments, per airline between SWCs and HWCs)
- Bridging (6 applicable, one per bridge port)

5.1.3 Special Facilities Routing

A customer may request that the facilities used to provide Special Access Service be specially routed. The regulations, rates and charges for Special Facilities Routing (i.e., Avoidance, Diversity and Cable-Only) are as described in Section 9.

5.1.4 Design Layout Report

The Telephone Company will provide to the customer the makeup of the Special Access provided under this tariff to aid the customer in designing its overall service. This information will be provided in the form of a Design Layout Report and will include the following:

- Cable gauge, length and loading.
- Makeup (e.g., T-Carrier, two-wire, four-wire, etc.)
- Specific pair of circuit assignment at the customer designated location.

The Design Layout Report will be provided to the customer within fourteen working days from the ASR Date. Updated reports will be reissued within fourteen working days whenever facilities provided to the customer are materially changed. Both the initial and updated Design Layout Reports will be provided to the customer at no charge.

WN U-16
Zipty Fiber

Original Sheet 329

FACILITIES FOR INTRASTATE ACCESS

5. SPECIAL ACCESS (Cont'd)

5.1 General (Cont'd)

5.1.5 Acceptance Testing

At the customer's request, the Telephone Company will cooperatively test, at the time of installation and at no additional charge, the following parameters:

- (A) For Voiceband services, acceptance testing will include tests for loss, 3-tone slope, DC continuity, operational signaling, C-notched noise, and C-message noise.

When the Interface Arrangement provides a four-wire voice transmission facility and the point of termination provides two-wire voice transmission (i.e., there is a four-wire to two-wire conversion at the point of termination) balance tests are also included in acceptance testing. When performing installation and acceptance testing, the Telephone Company will test the access service within the LATA.

On four-wire and effective four-wire circuits where the Network Channel Terminating Equipment (NCTE) has the capability of being remotely aligned, the Telephone Company may perform acceptance testing without a Telephone Company technician at the customer's premise. Should the customer request a technician be present at the customer's premise, additional charges will apply as specified in Section 6.2.

If the NCTE at the customer's premise does not have the capability of being aligned remotely, the additional charges will not apply. The Telephone Company will determine the type of NCTE placed at a customer's premise.

- (B) For other analog services (i.e., Program Audio, Video, Wideband Analog and Wideband Data Services) and for digital services (i.e., Digital Data Services and High Capacity Digital Services), acceptance testing will include tests identified in Section 5107 for the parameters applicable to the service as described in the Technical Interface Reference Manual for each of these services.

When the customer requests the performance of additional cooperative tests which are not required to meet these specified performance parameters, charges as found in 6.6 (B) will apply. All test results will be made available to the customer upon request.

If acceptance tests are not started within 30 minutes after pre-service tests have been completed and the customer has been notified by the Telephone Company, additional charges may apply, as specified in 6.2, unless the delay is caused by the Telephone Company.

WN U-16
Zipty Fiber

Original Sheet 330

FACILITIES FOR INTRASTATE ACCESS

5. SPECIAL ACCESS (Cont'd)

5.1 General (Cont'd)

5.1.6 Ordering Conditions

Ordering conditions are described in detail in Section 3. Also included in that section, are other charges which may be associated with ordering Special Access (e.g., Service Date Change Charges, Cancellation Charges, etc.).

(A) Determination of Jurisdiction of Mixed Use Special Access Service

When mixed interstate and intrastate Special Access Service is ordered, the jurisdiction will be determined as follows:

1. If the customer's estimate of the interstate traffic on the service involved constitutes 10% or less of the total traffic on that service, the service will be ordered and provided in accordance with the applicable rules and regulations of this tariff.
2. If the customer's estimate of the interstate traffic on the service involved constitutes more than 10% of the total traffic on that service, the service will be ordered and provided in accordance with the applicable rules and regulations of the interstate access Zipty Fiber FCC Tariff 2.

(B) Special Access Jurisdictional Verification

If a billing dispute arises or a regulatory commission questions the customer's estimate of the projected interstate percentage of traffic, the Telephone Company will ask the customer to provide the data the customer uses to determine the interstate percentage. The customer shall supply the data within 30 days of the Telephone Company request. The customer shall keep records of system design and functions from which the percentage of interstate and intrastate use can be ascertained and upon request of the Telephone Company make the records available for inspection as reasonably necessary for purposes of verification of the percentages.

WN U-16
Zipty Fiber

Original Sheet 331

FACILITIES FOR INTRASTATE ACCESS

5. SPECIAL ACCESS (Cont'd)

5.2 Description of Special Access

There are seven generic types of Special Access offerings. They are:

- Voiceband
- Program Audio
- Videoband
- Wideband Analog
- Wideband Data
- High Capacity Digital
- Digital Data Service

Each type has its own characteristics, and are subdivided by one or more of the following:

- Transmission specifications
- Bandwidth
- Speed (i.e., bit rate)
- Spectrum

The Special Access offerings described below are comprised of a combination of the rate elements described in 5.1.1. The following descriptions indicate the most effective use for each facility. Customer use for purposes other than those indicated is limited only to the extent that such use must not harm the network. Further, the Telephone Company does not guarantee transmission performance beyond the parameters identified in the descriptions.

The transmission performance characteristics of each Special Access offering are stated in the Technical Interface Reference Manual. The Telephone Company will maintain existing transmission specifications on services installed prior to the effective date of this tariff, except that existing services with performance specifications exceeding the standards in the Technical Interface Reference Manual will be maintained at the performance level specified in the manual.

The customer also has the option of ordering Voiceband and analog and digital high capacity facilities to a Telephone Company Hub for multiplexing to individual channels of a lower capacity or bandwidth. Descriptions of the types of multiplexing available at the Hubs, as well as the number of individual channels which may be derived from each type of facility, are described in 5.5. Additionally, the customer may specify supplemental features for the individual channels derived from the facility to further tailor the channel to meet specific communications requirements. Descriptions of the supplemental features available are described in 5.4.

For example, a customer may order a DS3 facility from a CDL to a Telephone Company Hub for multiplexing to 28 DS1 channels. The DS1 channels may be further multiplexed at the same or a different Hub to Voiceband or Wideband Analog (i.e., Group level) channels or may be extended to other CDLs. Optional features may be added to either the DS1 or the Voiceband Channels.

A customer may also order high capacity facilities from an end user's CDL to a Telephone Company Hub for the purpose of originating or terminating WATS. High capacity to voice multiplexing is required at the Hub.

WN U-16
ZiPLY Fiber

Original Sheet 332

FACILITIES FOR INTRASTATE ACCESS

5. SPECIAL ACCESS (Cont'd)

5.2 Description of Special Access (Cont'd)

5.2.1 Voiceband

(A) Two-Wire Voiceband Facility

These facilities are unconditioned and are capable of transmitting voice or data signals within the frequency spectrum of approximately 300 Hz to 3000 Hz. These facilities are furnished on a two-point or multipoint basis and may be terminated two-wire or four-wire at the point of termination. They permit the simultaneous transmission of information in both directions over a circuit, but it is not possible to ensure independent information transmission in both directions. Supplemental features may be added, at applicable charges, to enhance the operational capabilities of these facilities.

(B) Four-Wire Voiceband Facility

These facilities are unconditioned and are capable of transmitting voice or data signals within the frequency spectrum of approximately 300 Hz to 3000 Hz. The facilities are furnished on a two-point or multipoint basis and may be terminated two-wire or four-wire at the point of termination. When terminated four-wire, they permit simultaneous independent transmission of information in both directions over a circuit. However, when terminated two-wire, simultaneous independent transmission cannot be supported. Supplemental features may be added, at applicable charges, to enhance the operational capabilities of these facilities.

5.2.2 Program Audio

These facilities are arranged and provided for the transmission of non-broadcast audio which is used in connection with loudspeakers, wired music, closed circuit, or recordings. Facilities to be used in connection with broadcast audio must be ordered from the appropriate interstate tariff. Audio facilities are furnished for transmission in one direction. Audio facilities may be provided on a two-point or multi-point basis.

Program audio facilities are provided on either a full-time or part-time basis. The minimum periods for full-time and part-time service are in 3.2.4. When a part-time program audio service is provided for ten or more consecutive days it will be treated as a full-time service and rated accordingly. In no event will the charge for continuous part-time program audio exceed the amount that would have been charged in the same time period for full-time program audio facilities.

WN U-16
Zipty Fiber

Original Sheet 333

FACILITIES FOR INTRASTATE ACCESS

5. SPECIAL ACCESS (Cont'd)

5.2 Description of Special Access (Cont'd)

5.2.2 Program Audio (Cont'd)

Listed below are the types of Program Audio facilities that are offered under this tariff.

(A) 200 to 3500 Hz

Facilities are generally acceptable for speech quality programming and are subject to use over limited distance due to transmission factors.

(B) 100 to 5000 Hz

Facilities are generally acceptable for music and provide good quality speech programming.

(C) 50 to 8000 Hz

Facilities for the provision of high fidelity music transmission.

(D) 50 to 15000 Hz

Facilities for the provision of high fidelity music transmission. Two such facilities may be conditioned, at applicable charges, for stereo operation.

WN U-16
ZiPLY Fiber

Original Sheet 334

FACILITIES FOR INTRASTATE ACCESS

5. SPECIAL ACCESS (Cont'd)

5.2 Description of Special Access (Cont'd)

5.2.3 Videoband

Videoband facilities are arranged and provided for the transmission of television, which is to be used other than for broadcast purposes in connection with viewing or recording. Facilities to be used in connection with broadcast video services must be ordered from the appropriate interstate tariff.

The facilities are furnished for two point transmission in one direction only of United States 525 line/60 field standard monochrome and National Television Systems Committee (NTSC) color television baseband video signals and the associated audio signals.

Videoband Services are provided on a full-time or part-time (temporary) basis. The minimum periods are in 3.2.4 and 3.2.5. The monthly rates and nonrecurring charges for full-time Videoband Service will be developed on an Individual Case Basis. The hourly rates and nonrecurring charges for temporary service are those specified in 5.6.8.

There is a maximum monthly charge that may be assessed to any temporary Videoband Service as described in 5.6.1(C).

Technician Standby is a nonoptional arrangement furnished with temporary Videoband Service only. Technician Standby provides for Telephone Company monitoring of the temporary Video broadcast to ensure satisfactory transmission. At the option of the customer, additional technicians will be made available during the temporary Video broadcast; the customer will be assessed the Technician Standby charge.

A customer may request (as an option) an active, alternate temporary Videoband transmission path for use in the event that the primary service becomes inoperative. This is referred to as a "hot standby" facility. The charge for this additional service will be the nonrecurring charges and hourly rates in 5.6.5 for Temporary Videoband Facilities. Technician Standby charges are not applicable to the "hot standby" facility.

WN U-16
Zipty Fiber

Original Sheet 335

FACILITIES FOR INTRASTATE ACCESS

5. SPECIAL ACCESS (Cont'd)

5.2 Description of Special Access (Cont'd)

5.2.4 Wideband Analog

These facilities are two point and are furnished between CDLs or between a CDL and a Telephone Company designated Hub Wire Center where multiplexing is offered. The three types of Wideband Analog facilities are:

- (A) Group band facilities with a bandwidth from 60 kHz to 108 kHz for the transmission of a 12 circuit frequency division multiplexer (FDM) group.
- (B) Supergroup band facilities with a bandwidth from 312 kHz to 552 kHz for the transmission of a 60 circuit FDM supergroup.
- (C) Mastergroup band facilities with a bandwidth from 564 kHz to 3084 kHz for the transmission of a 600 circuit FDM mastergroup.

WN U-16
ZiPLY Fiber

Original Sheet 336

FACILITIES FOR INTRASTATE ACCESS

5. SPECIAL ACCESS (Cont'd)

5.2 Description of Special Access (Cont'd)

5.2.5 Wideband Data Service

These analog facilities are arranged and furnished for two-point simultaneous two-way transmission of high speed data between two CDLs. These facilities are normally utilized for the following data speeds: 19.2 Kbps, 50 Kbps, 56 Kbps and 230.4 Kbps.

5.2.6 High Capacity Digital

These facilities are two point and are furnished between CDLs or between a CDL and a Telephone Company designated Hub Wire Center where multiplexing is offered. High Capacity facilities may be used to provide Special Access Lines as described in 5.1.1(D). A High Capacity Voice Multiplexing Arrangement, as described in 5.5, is required at the Hub Wire Center.

- (A) DS1 facilities provide for the transmission of isochronous bipolar serial data at a rate of 1.544 Mbps.
- (B) DS1C facilities provide for the transmission of isochronous bipolar serial data at a rate of 3.152 Mbps.
- (C) FT1 facilities are furnished for the transmission of isochronous bipolar serial data and are available at transmission rate groupings of $N \times 56$ Kbps or $N \times 64$ Kbps where N equals 2, 4, or 6. FT1 channels are contiguous within the network and can be used to create a wideband circuit using customer provided equipment. When $N \times 64$ FT1 is ordered with DS1 service for multiplexing purposes, the DS1 must have Clear Channel Capability as described in 5.8.1. FT1 Service at a rate of $N \times 64$ Kbps will only be provided where Clear Channel Capability is available in the network. Where Clear Channel Capability is not available, $N \times 56$ Kbps service can be provided in lieu of $N \times 64$ Kbps. Fractional T1 is limited to those services so equipped and in service as of September 3, 1996.

WN U-16
Zipty Fiber

Original Sheet 337

FACILITIES FOR INTRASTATE ACCESS

5. SPECIAL ACCESS (Cont'd)

5.2 Description of Special Access (Cont'd)

5.2.6 High Capacity Digital (Cont'd)

- (D) FiberConnect service facilities which are only available as an OPP, provide for the transmission of an isochronous serial data stream at a rate of 6.312 Mbps, encoded and converted to a signal suitable for optical transport. FiberConnect service is transmitted on fiber optic cable. When FiberConnect is provided with a fiber optic interface at the CDL, a single transmission channel is provided with a data rate dependent on the Telephone Company fiber optic terminal equipment used to provision the facility. When FiberConnect is provided with an electrical interface, four transmission channels of 1.544 Mbps each are provided at the interface.

Fiber Optic Interface denotes the termination of service with single mode fiber optic cable at the customer premises. When this interface is selected, it is the customer's responsibility to provide the optical line termination at his premises. This equipment must be compatible with the Telephone Company provided equipment.

FiberConnect is offered only on a protected basis between a CDL and its serving wire center. FiberConnect is not available with multipoint services. Special Transport between serving wire centers for FiberConnect must be ordered as 4 DS1s.

WN U-16
Zipty Fiber

Original Sheet 338

FACILITIES FOR INTRASTATE ACCESS

5. SPECIAL ACCESS (Cont'd)

5.2 Description of Special Access (Cont'd)

5.2.6 High Capacity Digital (Cont'd)

- (E) DS3 facilities provide for the transmission of isochronous bipolar serial data at a rate of 44.736 Mbps. The Telephone Company will provide either an electrical or an optical interface with the service at the option of the customer. Ordering conditions are in 3.1.1(F).
- (F) DS3C facilities provide for the transmission of isochronous bipolar serial data at a rate of 89.472 Mbps. The Telephone Company will provide an optical interface with this service unless the service is provided via microwave, in which case an electro-magnetic interface is provided, or unless the customer requests an electrical interface.

5.2.7 Digital Data Service

Facilities for DDS are furnished for the simultaneous two-way transmission of synchronous data presently utilized for the following data speeds: 2.4 Kbps, 4.8 Kbps, 9.6 Kbps, 19.2 Kbps, 56 Kbps or 64 Kbps. DDS facilities may be provided on a two-point or multipoint basis.

5.2.8 Miscellaneous Special Access Services

A description of each service provided under Miscellaneous Special Access Services, along with the rate is found in Section 5.8.

5.3 Description of Terminating Options

Terminating Options provide a clearly delineated interface between Telephone Company and customer facilities at the point of termination at the CDL. Terminating Options facilitate the design, isolation, and testing of the Special Access. The description of each Terminating Option defines the most effective use of the Terminating Option. The technical parameters of each type of associated interface are described in the Technical Interface Reference Manual. Although a customer is not restricted from alternate applications, except where such application is harmful to the network, the Telephone Company cannot guarantee technical performance for other than the applications stated below. Terminating Options are nonchargeable.

WN U-16
ZiPLY Fiber

Original Sheet 339

FACILITIES FOR INTRASTATE ACCESS

5. SPECIAL ACCESS (Cont'd)

5.3 Description of Terminating Options (Cont'd)

5.3.1 Narrowband

(A) 0 to 75 Baud Type 1

Provides standard open/closed 20 or 62 Ma energized interface to customer terminal equipment and converts customer terminal equipment signals to voice frequency signaling for transmission over two-wire and four-wire voiceband network facilities suitable for voice grade to narrowband multiplexing. This terminating option is obsolete and is limited to those circuits so equipped and in service as of September 26, 1991.

(B) 0 to 75 Baud Type 2

Provides two-wire or four-wire metallic interface for customer or Telephone Company energized circuits. Telephone Company energized circuits are only available with voice grade to narrowband multiplexing. This option does not guarantee dc current operation over special transport facilities. This terminating option is obsolete and is limited to those circuits so equipped and in service as of September 26, 1991.

(C) 0 to 150 Baud

Provides standard RS-232C interface to customer terminal equipment and converts customer terminal equipment signals to voice frequency signaling for transmission over two-wire or four-wire voiceband facilities. This terminating option is obsolete and is limited to those circuits so equipped and in service as of September 26, 1991.

WN U-16
ZiPLY Fiber

Original Sheet 340

FACILITIES FOR INTRASTATE ACCESS

5. SPECIAL ACCESS (Cont'd)

5.3 Description of Terminating Options (Cont'd)

5.3.2 Voice Grade

(A) Two-Wire Voice Grade, Non-Data, Without Signaling

This option provides a two-wire interface to a customer and terminates an effective two-wire facility furnished for voice transmission only. Customer provided signaling must be limited to tones in the voiceband. Customer provided voiceband signaling equipment must limit transmission power to 0.0 dBm peak and -13 dBm average power over a three-second period.

(B) Four-Wire Voice Grade, Non-Data, Without Signaling

This option provides a four-wire interface to customer terminal equipment and terminates an effective four-wire facility furnished for voice transmission only. Customer provided signaling must be limited to tones in the voiceband. Customer provided voiceband signaling equipment must limit transmission power to 0.0 dBm peak and -13 dBm average power over a three-second period.

(C) Voice Grade Data Termination

This option provides a two-wire or four-wire transmission interface to a customer's private line data modem and terminates an effective four-wire facility furnished for voiceband data transmission.

FACILITIES FOR INTRASTATE ACCESS

5. SPECIAL ACCESS (Cont'd)5.3 Description of Terminating Options (Cont'd)5.3.2 Voice Grade (Cont'd)(D) Two-Wire Voice Grade Station Connecting Facility Termination

This option provides a means to terminate an effective two-wire facility or an effective four-wire facility with a two-wire customer interface on a telephone, key system, PBX, ACD, or similar equipment. This option is normally used to terminate facilities that furnish foreign central office service, the station end of PBX off premises service, or private switched service network access lines. The option provides both the transmission and loop signaling functions normally associated with these services. The option is also used to terminate facilities arranged with automatic ringdown signaling. This option provides the loop and ringdown signaling with the facility.

(E) Four-Wire Voice Grade Station Connecting Facility Termination

A terminating option similar to (D) used to terminate effective four-wire foreign central office service. The option provides a four-wire transmission interface to the customer terminal equipment and the loop signaling function normally associated with these services. This option provides the loop and ringdown signaling with the facility.

(F) Two-Wire Station Connecting Facility Termination for the Open End of an Off Premises PBX Extension

Terminating options are available depending on the signaling range of the PBX (or similar system) as defined in 47 CFR § 68.1 et al. Type 1 is an option requiring range extension equipment at the CDL. Type 2 is an option with no range extension equipment at the CDL. If needed, the loop signaling range equipment for Type 1 must be specifically specified, see Section 5.4.4 for available arrangements.

(G) Dial Repeating Tie Trunk Termination

Two network terminating options are provided for terminating four-wire transmission facilities used to furnish dial repeating tie trunk services. These options are described in terms of the interface they provide to a PBX (or similar system).

- (1) A Type I tie line termination provides the customer with a two-wire transmission interface and includes either two-wire or four-wire E&M type signaling. Transmission and signaling interface options available are described in 47 CFR § 68.1 et al. This option provides the E&M type signaling with the facility.
-

WN U-16
ZiPLY Fiber

Original Sheet 342

FACILITIES FOR INTRASTATE ACCESS

5. SPECIAL ACCESS (Cont'd)

5.3 Description of Terminating Options (Cont'd)

5.3.2 Voice Grade (Cont'd)

(G) Dial Repeating Tie Trunk Termination (Cont'd)

- (2) A Type III tie line termination provides the customer with a four-wire transmission interface and includes either two-wire or four-wire E&M type signaling. Transmission and signaling options available are described in 47 CFR § 68.1 et al. This option provides the E&M signaling with the facility.

Special Access Line and Special Transport facilities used with this option may require signaling capabilities as described in 5.4.4.

5.3.3 Program Audio

(A) 200 to 3500 Hz

Provides standard program audio interface levels and impedance matching to two-wire network facilities.

(B) 100 to 5000 Hz, 50 to 8000 Hz, and 50 to 15000 Hz

Provides standard program audio interface levels, circuit equalization and impedance matching to two-wire network facilities.

WN U-16
Zipty Fiber

Original Sheet 343

FACILITIES FOR INTRASTATE ACCESS

5. SPECIAL ACCESS (Cont'd)

5.3 Description of Terminating Options (Cont'd)

5.3.4 Videoband

Provides a videoband special Access Line interface for use in providing the one way transmission of video signals.

Standard Videoband service is provided via one signal (combined video and audio). This signal is in the 30 Hz to 6.6 MHz frequency range. It includes a one-way duplexed transmission of standard 525 lines/60 fields monochrome or NTSC color video signal, and one associated 15 KHz audio signal.

As an option the customer may select to receive Videoband service via two signals (one video and one audio). Under this option, the signal received will be in the 30 Hz to 4.5 MHz frequency range and the audio signal will be in the 50 Hz to 15000 Hz frequency range.

5.3.5 Wideband Data Service

Provides a Wideband Data Service Special Access interface for of use in providing two-way transmission of sequential synchronous or nonsynchronous data at rates of 19.2, 50 or 230.4 Kbps; or sequential synchronous bipolar data signals at a rate of 56 Kbps over four-wire facilities.

FACILITIES FOR INTRASTATE ACCESS

5. SPECIAL ACCESS (Cont'd)5.3 Description of Terminating Options (Cont'd)5.3.6 High Capacity Digital(A) High Capacity Digital DS1

Provides a High Capacity Digital DS1 Special Access interface for use in providing simultaneous two-way transmission of isochronous bipolar serial data signals at the rate of 1.544 Mbps.

(B) High Capacity Digital DS1C

Provides a high capacity digital DS1C Special Access interface for use in providing simultaneous two-way transmission of isochronous bipolar serial data signals at the rate of 3.152 Mbps.

(C) Fractional T1 Service

Provides a DS1 Special Access interface for use in providing simultaneous two-way transmission of isochronous bipolar serial data signals and is limited to groupings of N x 56 Kbps or N x 64 Kbps where N equals 2, 4, or 6.

(D) FiberConnect Service

Provides a High Capacity Digital Special Access interface for use in providing simultaneous two-way transmission of isochronous bipolar serial data. The Telephone Company, at the option of the customer, will provide either an electrical or a fiber optic interface. The electrical interface option provides four electrical channels at 1.544 Mbps each. The fiber optic interface option is provided on a single mode fiber and terminates on fiber optic connectors. The 6.312 Mbps signal will be made up of four transmission channels of 1.544 Mbps each and will be encoded to an optical data rate dependent on the fiber optic terminal equipment used by the Telephone Company to provision the facility.

When the optical interface is selected, it is the customer's responsibility to provide the optical line termination at his premises. This equipment must be compatible with the equipment provided by the Telephone Company. Service will be provided on a one for one protected basis only.

WN U-16
ZiPLY Fiber

Original Sheet 345

FACILITIES FOR INTRASTATE ACCESS

5. SPECIAL ACCESS (Cont'd)

5.3 Description of Terminating Options (Cont'd)

5.3.6 High Capacity Digital

(E) High Capacity Digital DS3

Provides a High Capacity Digital DS3 Special Access interface for use in providing simultaneous two-way transmission of isochronous bipolar serial data signals at the rate of 44.736 Mbps. The Telephone Company will provide either an electrical or an optical interface with the service as specified by the customer. Ordering conditions are in 3.1.1(F).

(F) High Capacity Digital DS3C

Provides a High Capacity Digital DS3C Special Access interface for use in providing simultaneous two-way transmission of isochronous bipolar serial data signals at the rate of 89.472 Mbps. The Telephone Company will provide an optical interface with this service unless the service is provided via microwave, in which case, an electromagnetic interface is provided, or unless the customer requests an electrical interface.

5.3.7 Digital Data Service

Provides DDS Special Access interface for use in providing simultaneous two-way transmission of sequential bipolar data signals at rates of 2.4 Kbps, 4.8 Kbps, 9.6 Kbps, 19.2 Kbps, 56 Kbps or 64 Kbps over four-wire facilities.

WN U-16
ZiPLY Fiber

Original Sheet 346

FACILITIES FOR INTRASTATE ACCESS

5. SPECIAL ACCESS (Cont'd)

5.4 Description of Supplemental Features

Supplemental Features are items which can be added to a Special Access service to provide enhanced capabilities or improve its utility. References to specific uses or Special Access types indicate the most effective use for each Supplemental Feature. Customer use for other purposes or with other Special Access types is limited only to the extent that such use must not harm the network. Further, the Telephone Company does not guarantee functional operation of Supplemental Features for these alternate applications.

Listed below are the Supplemental Features that are offered under this tariff.

5.4.1 Bridging

Bridging is the function of connecting three or more CDLs in a multipoint arrangement. Listed below are those bridging services offered under this tariff.

(A) MultiPoint Data Bridging

This feature provides the capability to derive a multipoint data circuit from a single facility and is normally provided on Voiceband facilities provided for transmission of data signals. This function is provided on a per port basis. Polled multipoint data circuits are a typical application of this feature.

(B) Voice Conference Bridging

Bridging arrangement to connect multiple Voiceband facilities in order that a voice frequency input signal from any location will be reproduced at the output of all other circuit locations. This function is provided on a per port basis.

(C) Alarm Distribution Bridging

Provides polling type bridging capabilities, band splitting filters and conversion of four-wire common terminations up to a capacity of 40 two-wire terminations. This function is offered as two tariff elements. The first element provides all shelving and common equipment for a capacity of 40 two-wire terminations. The second element provides a two-wire port. One common equipment rate element will apply to accommodate up to 40 two-wire terminations. One two-wire port charge will apply to each two-wire Special Access Line terminated in the bridge.

(D) Program Audio Bridging

An arrangement to provide multiple channel outputs from a single Program Audio or Voiceband facility. This arrangement is provided on a per port basis.

WN U-16
ZiPLY Fiber

Original Sheet 347

FACILITIES FOR INTRASTATE ACCESS

5. SPECIAL ACCESS (Cont'd)

5.4 Description of Supplemental Features (Cont'd)

5.4.1 Bridging (Cont'd)

(E) Dataphone Select-A-Station Bridging

Provides for the connection of a master station location to a number of remote stations. The capacity of this bridging arrangement will vary from a minimum of 21 stations to a maximum of 84 stations dependent upon the mixture of four-wire and two-wire ports equipped. This arrangement is provided per AT&T Technical Reference PUB 41014. Charges consist of a rate for either common equipment-addressable or common equipment-sequential, plus a rate for each four-wire port connected or for each two-wire port connected.

(F) DDS Bridging

Provides for a multi-junction unit (MJU) arrangement to bridge 2.4 Kbps, 4.8 Kbps, 9.6 Kbps or 56 Kbps DDS facilities. Different speeds cannot be mixed on the same bridge. This function is provided on a per port basis.

5.4.2 Conditioning Arrangements - Data

Data conditioning, when utilized with effective four-wire Voiceband transmission facilities, improves the characteristics of these facilities. These improved characteristics are not represented to apply to the entire end to end facility of the customer, but only to that portion of the facility provided by the Telephone Company.

There are two types of data conditioning: Type C and Type DA. Type C conditioning controls attenuation distortion and envelope delay distortion. Type DA controls the signal to C-notched noise ratio and intermodulation distortion. Type C and Type DA conditioning may be combined on the same circuit.

Data conditioning is charged for on a per Special Access line basis. The parameters listed for each type of data conditioning apply from two or more CDLs located within the Telephone Company serving area. Conditioning parameters apply to each end of a two-point circuit. For multipoint circuits, the conditioning parameters apply from any CDL to either the point of interface at another CDL or the first Telephone Company bridging point depending on the circuit configuration. These parameters are not applicable to High Capacity or Wideband Analog points of interface, because there is no voice frequency test access point. In these instances the data conditioning parameters apply to the last telephone company voice frequency test access point before the High Capacity or Wideband Analog point of interface.

WN U-16
Zipty Fiber

Original Sheet 348

FACILITIES FOR INTRASTATE ACCESS

5. SPECIAL ACCESS (Cont'd)

5.4 Description of Supplemental Features (Cont'd)

5.4.2 Conditioning Arrangements - Data (Cont'd)

(A) Type C

Type C conditioning of Voiceband facilities provides a facility with the following transmission parameters enhanced to meet the values specified for Type C conditioning in the Technical Interface Reference Manual in addition to the standard parameters for Voiceband circuits.

- (1) Attenuation distortion with reference to 1004 Hz.
- (2) Envelope delay distortion.

(B) Type DA

Type DA conditioning of Voiceband facilities provides a facility with the following transmission parameters enhanced to meet the values specified for Type DA conditioning in the Technical Interface Reference Manual in addition to the standard parameters for voiceband circuits.

- (1) Signal to C-notched noise ratio.
- (2) Nonlinear signal to second order distortion.
- (3) Nonlinear signal to third order distortion.

5.4.3 Conditioning - Program Audio

(A) Stereo Conditioning

Provides the selection of two radio program facilities which are identical in all transmission characteristics. Two Program Audio facilities are required to provide this Supplemental Feature. This feature is normally used only with Program Audio 50 to 15000 Hz facilities. Stereo Conditioning is charged on a per Special Access Line basis.

(B) Zero Loss

Conditioning of Program Audio facilities to provide zero loss at 1000 Hz test frequency. Zero Loss is charged on a per Special Access Line basis.

WN U-16
ZiPLY Fiber

Original Sheet 349

FACILITIES FOR INTRASTATE ACCESS

5. SPECIAL ACCESS (Cont'd)

5.4 Description of Supplemental Features (Cont'd)

5.4.4 Signaling Arrangements

Signaling arrangements, when furnished with Voiceband transmission facilities, enable the facilities to accommodate standard telecommunications signaling protocols. Signaling arrangements provide for the conversion of one signaling method to another signaling method and/or extension of a signaling method at customer and Telephone Company interfaces and enables the transmission facilities to accommodate signaling transmission. Signaling arrangements are available with Voiceband transmission facilities to enable transmission of requested signaling formats. The third and fourth protocol characters of the Network Channel Interface (NCI) and Secondary Network Channel Interface (SEC NCI) codes as indicated on the customer's order, reflect signaling activity. Typical protocol characters contained in the NCI or SEC NCI codes that designate signaling arrangements are: AB, AC, DS, DX, DY, EA, EB, EC, EX, GO, GS, LA, LB, LC, LO, LR, LS, NO, RV and SF.

The customer identified NCI and SEC NCI codes will be considered the customer's request for signaling. The Telephone Company will endeavor to provide the specific signaling protocols requested by the customer. In those cases where facilities and equipment are not available to meet the customer's specific requests, the Telephone Company will provide the customer acceptable alternate protocols. The Technical Interface Reference Manual provides detailed technical descriptions of the signaling protocols normally available with each service offering. To properly provision SF signaling, when associated signaling code, is DS (PCM), additional information of SF requirements (loop signaling type DX/E&M or ringdown) must accompany the customer's order.

WN U-16
ZiPLY Fiber

Original Sheet 350

FACILITIES FOR INTRASTATE ACCESS

5. SPECIAL ACCESS (Cont'd)

5.4 Description of Supplemental Features (Cont'd)

5.4.4 Signaling Arrangements (Cont'd)

Signaling arrangement charges apply whenever interfaces at the customer premises or at the customer's Telephone Company serving wire center require a signaling arrangement other than those provided with the Terminating Options in 5.3.2. Signaling Arrangements will be charged on a per SAL basis. Specifically, a signaling charge applies if the signaling protocol characters in the NCI and the SEC NCI fields are different and include on the following codes: RV, EX, SF, DX, DY, DS, AB.

For the above conditions, one additional signaling charge applies for each additional leg of multipoint circuit. When a Multiplexing Arrangement is ordered that converts a single higher capacity or bandwidth circuit into several lower Voiceband circuits, the Voiceband Signaling Arrangements are provided as part of the Multiplexing Arrangement, and no additional Signaling Arrangement charges will apply.

A signaling charge applies in addition to any other applicable signaling charge when loop range extension equipment is required. The Telephone Company will obtain customer approval for signaling range extension equipment.

Listed below are the Signaling Arrangements offered under this tariff:

- (A) Loop Signaling Range Extension - An arrangement to extend the metallic resistance limitations of loop type signaling.

WN U-16
Zipty Fiber

Original Sheet 351

FACILITIES FOR INTRASTATE ACCESS

5. SPECIAL ACCESS (Cont'd)

5.4 Description of Supplemental Features (Cont'd)

5.4.4 Signaling Arrangements (Cont'd)

- (B) Conversion of Loop or E&M Signaling to SF - An arrangement to convert loop or E&M signaling to the single frequency signaling format.
- (C) E&M to DX Signaling Conversion - Conversion of E&M signaling to the DX signaling format.
- (D) E&M to Loop Signaling Conversion - Conversion of E&M signaling format to the loop type signaling.
- (E) Loop or E&M to PCM Signaling - Conversion of loop or E&M signaling to the digital (PCM) signaling format.
- (F) Automatic Ringdown Signaling (ARD) - A signaling arrangement on a two-point Special Access which converts loop seizure at one end of the facility into ringing signal at the opposite end.

5.4.5 Echo Control

(A) Echo Suppression

An arrangement provided at the customer's request to attenuate reflected speech energy on a four-wire facility. This conditioning is generally required on circuits with long propagation delay. Echo suppression is charged on a per Special Access circuit basis. Echo suppression is an obsolete service offering and is applicable only to those circuits equipped with echo suppression prior to January 1, 1987. Any service rearrangements or order activity on the circuits equipped with echo suppression may require a change to echo canceller as described in 5.4.5(B).

WN U-16
Zipty Fiber

Original Sheet 352

FACILITIES FOR INTRASTATE ACCESS

5. SPECIAL ACCESS (Cont'd)

5.4 Description of Supplemental Features (Cont'd)

5.4.5 Echo Control (Cont'd)

(B) Echo Canceller

An arrangement provided at the customer's request to cancel reflected speech energy on a four-wire facility. This conditioning is generally required on circuits with long propagation delay. Echo canceller is charged on a per Special Access circuit basis.

5.4.6 Improved Return Loss

Improved Return Loss provides for increased echo return and singing return parameters of an effective two-wire channel. This optional feature is available with certain Voiceband services at a two-wire point of termination when the transmission interface is four-wire at one CDL and two-wire at the other CDL. Placement of Telephone Company equipment may be required at the customer's premises with the two-wire point of termination.

Improved Return Loss rates and charges will apply on a per Special Access Line basis at the rates specified in 5.7.5. Technical parameters and the applicable Voiceband services are specified in the Technical Interface Reference Manual.

5.4.7 Voiceband Facility Switching Arrangement

An arrangement to provide switching between two Voiceband Special Access Services. This arrangement may require a Voiceband control circuit to control the switching arrangement at an additional charge.

WN U-16
ZiPLY Fiber

Original Sheet 353

FACILITIES FOR INTRASTATE ACCESS

5. SPECIAL ACCESS (Cont'd)

5.4 Description of Supplemental Features (Cont'd)

5.4.8 Automatic Protection Switch

Consists of special switching equipment placed at both ends of a duplicate DS1 facility (i.e., DS1, High Capacity Circuit) for automatic switching to the duplicate (standby) facility in the event the active facility is inoperative.

Duplicate facilities may terminate at a serving wire center, a CDL or both. The option provided under this tariff only includes the APS(s) located at a serving wire center(s). When the duplicate facility terminates at a CDL, the customer will be responsible for providing the associated APS and ensuring it is compatible with the Telephone Company provided switch if appropriate.

The duplicate facilities are not a part of this supplemental feature.

5.4.9 Improved Termination Option

Improved Termination provides for a fixed 600 ohm impedance, an increased range of transmission levels, and simplex reversal (when applicable) on an effective four-wire channel. This optional feature is available with most Voiceband services with a four-wire point of termination. Telephone Company equipment is required at the customer's premises where this option is ordered.

The Improved Termination option will be ordered and rates and charges, as in 5.7.2, will apply on a per SAL basis. Technical parameters and the applicable Voiceband services are specified in the Technical Interface Reference Manual.

WN U-16
Zipty Fiber

Original Sheet 354

FACILITIES FOR INTRASTATE ACCESS

5. SPECIAL ACCESS (Cont'd)

5.4 Description of Supplemental Features (Cont'd)

5.4.10 Improved Equal Level Echo Path Loss Option - ELEPL-2

This option provides improved echo control parameters for an effective two-wire channel at a four-wire point of termination. Placement of Telephone Company equipment may be required at the customer's premises with the two-wire point of termination.

The term "Equal Level Echo Path Loss" (ELEPL) represents the measure of Echo Path Loss (EPL) at a four-wire interface which is corrected by the difference between the send and receive Transmission Level Point (TLP), i.e., $ELEPL - EPL - TLP(\text{send}) + TLP(\text{receive})$.

Improved ELEPL rates and charges will apply on a per SAL basis at the rates in 5.7.2. Technical parameters are specified in Section 7000 of the Technical Interface Reference Manual.

5.5 Description of Multiplexing Arrangements

Multiplexing Arrangements provide the function to convert a single higher capacity or bandwidth circuit for bulk transport to several lower capacity or bandwidth circuits. Cascading multiplexing occurs when a high capacity analog or digital channel is de-multiplexed to provide channels with a lesser capacity and one of the lesser capacity channels is further de-multiplexed. For example, a DS1C may be de-multiplexed to two DS1 facilities and then the DS1 facilities may be further de-multiplexed to 24 Voiceband channels.

When cascading multiplexing is performed in the same or different Hub Wire Center, a charge for the additional multiplexing unit will also apply. When cascading multiplexing is performed at a different Hub Wire Center, Special Transport will also apply between the involved Hub Wire Centers.

WN U-16
Zipty Fiber

Original Sheet 355

FACILITIES FOR INTRASTATE ACCESS

5. SPECIAL ACCESS (Cont'd)

5.5 Description of Multiplexing Arrangements (Cont'd)

Listed below are the multiplexing arrangements offered under this tariff.

5.5.1 Voice to Narrowband

An arrangement that multiplexes sixteen 0 to 75 baud narrowband circuits to a single voice grade circuit, or a single voice grade circuit to sixteen 0 to 75 baud narrowband circuits. This arrangement is an obsolete offering and is limited to those circuits so equipped and in service as of September 26, 1991.

5.5.2 Group to Voice

An arrangement that multiplexes twelve voice grade circuits to a single wideband analog group band circuit, or multiplexes a single wideband analog group band circuit to twelve voice grade circuits.

5.5.3 Supergroup to Group

An arrangement that multiplexes five wideband analog group band circuits to a single wideband analog supergroup band circuit, or multiplexes a single wideband analog supergroup band circuit to five wideband analog group band circuits.

5.5.4 Mastergroup to Supergroup

An arrangement that multiplexes ten wideband analog supergroup band circuits to a single wideband analog mastergroup band circuit, or multiplexes a single wideband analog mastergroup band circuit to ten wideband analog supergroup band circuits.

WN U-16
ZiPLY Fiber

Original Sheet 356

FACILITIES FOR INTRASTATE ACCESS

5. SPECIAL ACCESS (Cont'd)

5.5 Description of Multiplexing Arrangements (Cont'd)

5.5.5 DS1 to Voice

An arrangement that multiplexes twenty-four voice grade circuits to a single DS1 digital circuit at a rate of 1.544 Mbps, or multiplexes a single DS1 digital circuit at a rate of 1.544 Mbps to twenty-four voice grade circuits. If this DS1 terminates in a DDS hub, a channel(s) of the DS1 can be used to provide DDS; however, DDS service stops at the DS1 interface. Multiple channels may be required to provide individual Program Audio Channels.

Up to 16 channels of this DS1 can be used for Direct Digital Service (DDS-like service) with the assurance that circuit performance parameters will be met. If more than 16 channels are used for DDS-like service, the performance parameters for the DS1 and all circuits riding the DS1 will not be guaranteed.

FT1 can be used with DS1 to Voice Multiplexing in groupings of $N \times 56$ Kbps or $N \times 64$ Kbps where $N = 2, 4$ or 6 , to a single DS1 digital circuit at a rate of 1.544 Mbps. Fractional T1 is limited to those services so equipped and in service as of September 3, 1996.

5.5.6 DS1C to Voice

An arrangement that multiplexes forty-eight voice grade circuits to a single DS1C digital circuit at a rate of 3.152 Mbps, or multiplexes a single DS1C digital circuit at a rate of 3.152 Mbps to forty-eight voice grade circuits.

WN U-16
Zipty Fiber

Original Sheet 357

FACILITIES FOR INTRASTATE ACCESS

5. SPECIAL ACCESS (Cont'd)

5.5 Description of Multiplexing Arrangements (Cont'd)

5.5.7 DS1C to DS1

An arrangement that multiplexes two DS1 digital circuits to a single DS1C digital circuit at a rate of 3.152 Mbps, or multiplexes a single DS1C digital circuit at a rate of 3.152 Mbps to two DS1 digital circuits.

5.5.8 DS3 to DS1

An arrangement that multiplexes twenty-eight DS1 digital circuits to a single DS3 digital circuit at a rate of 44.736 Mbps, or multiplexes a single DS3 digital circuit at a rate of 44.736 Mbps to twenty-eight DS1 digital circuits.

5.5.9 DS3C to DS1

An arrangement that multiplexes fifty-six DS1 digital circuits to a single DS3C digital circuit at a rate of 89.472 Mbps, or multiplexes a single DS3C digital circuit at a rate of 89.472 Mbps to fifty-six DS1 digital circuits.

WN U-16
Zipty Fiber

Original Sheet 358

FACILITIES FOR INTRASTATE ACCESS

5. SPECIAL ACCESS (Cont'd)

5.5 Description of Multiplexing Arrangements (Cont'd)

5.5.10 Group to DS1

An arrangement that multiplexes two wideband analog groupband circuits to a single DS1 digital circuit at a rate of 1.544 Mbps, or multiplexes a single DS1 digital circuit at a rate of 1.544 Mbps to two wideband analog groupband circuits.

5.5.11 Digital Data Carrier Multiplexer

An arrangement that multiplexes a single DS1 1.544 Mbps digital circuit to twenty-three DS0 digital ports for connection to either a subrate data multiplexer as described in 5.5.12 or 56 Kbps digital circuits.

5.5.12 Digital Data Subrate Multiplexer

Used with cascading multiplexing, the Digital Data Subrate Multiplexer is an arrangement that multiplexes the following quantities of subrate digital data circuits into a single DS0 digital port: 1) twenty 2.4 Kbps, 2) ten 4.8 Kbps or 3) five 9.6 Kbps. In turn, the DS0 digital port is then multiplexed to a single DS1 digital circuit using the Digital Data Carrier Multiplexer described in 5.5.11.

WN U-16
Zipty Fiber

Original Sheet 359

FACILITIES FOR INTRASTATE ACCESS

5. SPECIAL ACCESS (Cont'd)

5.6 Rate Regulations

This section contains specific regulations governing the rates and charges that apply for Special Access Service.

5.6.1 Types of Rates and Charges

There are four types of rates and charges. These are monthly rates, daily rates, hourly rates and nonrecurring charges. The rates and charges are described as follows:

(A) Monthly Rates

Monthly rates are recurring charges that apply each month or fraction thereof that a Special Access Service is provided. For billing purposes, each month is considered to have 30 days.

(B) Daily Rates

Daily rates are recurring charges that apply to each 24 hour period or fraction thereof that a part-time Program Audio Special Access Service is provided. This 24 hour period is not limited to a calendar day. When part-time Program Audio service is provided for ten or more consecutive days it will be treated as a full-time service and monthly rates will apply. In no event will the charges for continuous part-time Program Audio service exceed the amount that would be charged in the same time period for full-time service.

WN U-16
Zipty Fiber

Original Sheet 360

FACILITIES FOR INTRASTATE ACCESS

5. SPECIAL ACCESS (Cont'd)

5.6 Rate Regulations (Cont'd)

5.6.1 Types of Rates and Charges (Cont'd)

(C) Hourly Rates

Hourly rates are recurring charges that apply to each 60 minute period, or fraction thereof, that a part-time Videoband Special Access Service is provided. There is a maximum monthly charge that may be assessed to any Temporary Videoband Special Access Service when that service is provided during continuous hours of broadcast, or during consecutive days in any given month. The maximum charge during any billing month will be that amount equal to 100 hours of use.

(D) Nonrecurring Charges

Nonrecurring charges are one-time charges that apply for specific work activity, (i.e., installation of service or change to an existing service). The types of nonrecurring charges that apply for Special Access Service are those listed below.

(1) Special Access Ordering Charges

Special Access Ordering Charges are associated with the work performed by the Telephone Company in connection with the receiving, recording and processing of customer service requests. There are two types of service ordering charges.

WN U-16
ZiPLY Fiber

Original Sheet 361

FACILITIES FOR INTRASTATE ACCESS

5. SPECIAL ACCESS (Cont'd)

5.6 Rate Regulations (Cont'd)

5.6.1 Types of Rates and Charges (Cont'd)

(D) Nonrecurring Charges (Cont'd)

(1) Special Access Ordering Charges (Cont'd)

(a) Initial Ordering Charge - Special Access

This charge applies on a per Access Service Request (ASR) basis, including those requests to add additional terminations to an existing service.

(b) Subsequent Ordering Charge - Special Access

This charge applies on a per ASR basis for modifications to an existing service. This would include activities such as:

1. Additions of supplemental features and multiplexing arrangements.
2. Changes of a WATS telephone number.
3. Changes of a WATS Access Screening Arrangement.
4. Changes in a WATS hunt group arrangement.
5. Changes in the type of transport rate option from Switched Transport to Special Transport for FGA and FGB Switched Access Service as described in 4.1.

WN U-16
Zipty Fiber

Original Sheet 362

FACILITIES FOR INTRASTATE ACCESS

5. SPECIAL ACCESS (Cont'd)

5.6 Rate Regulations (Cont'd)

5.6.1 Types of Rates and Charges (Cont'd)

(D) Nonrecurring Charges (Cont'd)

(2) Service Installation Charge

The Service Installation Charge is associated with the work performed by the Telephone Company in connection with the physical installation activities involving central office and/or outside plant facilities. This charge applies on a per SAL basis for the installation of service, and for additional terminations to existing service.

This charge does not apply to installations involving DS1 and DS3 SALs or to Temporary Videoband Services. The installation charge for these services are in 5.6.1(D)(5) and (6). In addition, this charge will not apply to part-time Program Audio SALs which are left in place and reused.

(3) Design Change Charge

The customer may request a design change to the service ordered. A design change is any change to a pending ASR for Special Access Service which requires engineering review. Design changes include such things as the addition or deletion of optional features or minor changes in the interface arrangement (e.g., 04LGXX to O2LGXX). Design changes do not include a change of IC CDL, end user premises or Special Access channel type (e.g., O4LGXX to O4DSXX). Changes of this nature will require the issuance of a new ASR and the cancellation of the original ASR. The cancellation charges apply as in 3.2.6.

WN U-16
Zipty Fiber

Original Sheet 363

FACILITIES FOR INTRASTATE ACCESS

5. SPECIAL ACCESS (Cont'd)

5.6 Rate Regulations (Cont'd)

5.6.1 Types of Rates and Charges (Cont'd)

(D) Nonrecurring Charges (Cont'd)

(3) Design Change Charge (Cont'd)

The Telephone Company will review the requested change, notify the customer whether the change can be accommodated and specify if a new service date is required. If the customer authorizes the Telephone Company to proceed with the design change, a Design Change Charge will apply.

The Design Change Charge in 5.7.1 will apply on a per ASR per occurrence basis, for each ASR requiring a design change.

If a change of service date is required, the Service Date Change Charge in Section 3 will also apply.

(4) Installation of Supplemental Features and Multiplexing Arrangements

Nonrecurring charges apply for the installation of supplemental features and multiplexing arrangements available with Special Access service. The charge applies whether the feature or multiplexing arrangement is installed coincident with the initial installation of service or at any time subsequent to the installation of service. These charges are in addition to the appropriate Special Access Ordering Charge in 5.6.1(D)(1).

WN U-16
ZiPLY Fiber

Original Sheet 364

FACILITIES FOR INTRASTATE ACCESS

5. SPECIAL ACCESS (Cont'd)

5.6 Rate Regulations (Cont'd)

5.6.1 Types of Rates and Charges (Cont'd)

(D) Nonrecurring Charges (Cont'd)

(5) Installation of DS1, FiberConnect FT1, DDS and DS3 Special Access Lines

(a) DS1 Standard Arrangements

There are two levels of NRC and monthly charges for the installation of a DS1 SAL as described in 5.7.10. The "First System" charge is assessed per SAL for the first DS1 Service ordered by a customer between CDLs or a Hub Wire Center. When the same customer requests additional DS1 Service on the same ASR, to be installed at the same time and between the same CDLs as the "First System" DS1 SAL, the lesser charge under "Additional System" will apply. In addition to these charges, the appropriate Special Access Ordering Charge as described in 5.6.1(D)(1) will apply. The charge is found in 5.7.1.

(b) FiberConnect Service Optional Payment Plan (OPP) Arrangement

Customers subscribing to the FiberConnect OPP arrangements, at rates in 5.7.9, will be assessed a nonrecurring charge. The NRC represents the termination of four DS1 equivalent SALs on a single fiber optic transmission System. The customer must order four DS1s and indicate on the ASR the Network Channel Interface (NCI) code for either electrical or fiber optic termination.

The NRC for installation of a FiberConnect OPP SAL in 5.7.9 will apply to existing FiberConnect OPP customers when required for changes and other service rearrangements as described in 5.6.1(D)(7).

WN U-16
Zipty Fiber

Original Sheet 365

FACILITIES FOR INTRASTATE ACCESS

5. SPECIAL ACCESS (Cont'd)

5.6 Rate Regulations (Cont'd)

5.6.1 Types of Rates and Charges (Cont'd)

(D) Nonrecurring Charges (Cont'd)

(6) Installation of Temporary Videoband Service

Installation charges will be developed on an individual case basis (ICB).

No other nonrecurring charges [i.e., those described in 5.6.1(D)(1) and (2)] will be assessed to the installation of Temporary Videoband Service.

(7) Service Rearrangements

Service rearrangements are changes to existing (installed) services which may be administrative only in nature, or involve an actual physical change to the service. Changes to pending orders are as in 3.2.2.

Changes in the type of service will be treated as a discontinuance of the service and an installation of a new service.

Changes in the physical location of the point of termination are treated as moves which are described and charged for as in 5.6.4.

Administrative changes will be made without charge(s) to the customer.

WN U-16
Zipty Fiber

Original Sheet 366

FACILITIES FOR INTRASTATE ACCESS

5. SPECIAL ACCESS (Cont'd)

5.6 Rate Regulations (Cont'd)

5.6.1 Types of Rates and Charges (Cont'd)

(D) Nonrecurring Charges (Cont'd)

(7) Service Rearrangements (Cont'd)

Administrative changes are as follows:

- Change in name or ownership or transfer of responsibility from one customer to another, provided there is no interruption of use or relocation of Special Access service.
- Change of customer or customer's end user premises address when the change of address is not a result of a physical relocation of equipment,
- Change in billing data (name, address, or contact name or telephone number),
- Change of customer circuit identification,
- Change of billing account number,
- Change of customer test line number,
- Change of customer or customer's end user contact name or telephone number,
- Change of agency authorization, and
- Change in jurisdiction involving no physical changes to the service.

Issued: July 29, 2020
Issued by Zipty Fiber
By Jessica Epley, Regulatory & External Affairs Director

Effective: July 31, 2020

WN U-16
Zipty Fiber

Original Sheet 367

FACILITIES FOR INTRASTATE ACCESS

5. SPECIAL ACCESS (Cont'd)

5.6 Rate Regulations (Cont'd)

5.6.1 Types of Rates and Charges (Cont'd)

(D) Nonrecurring Charges (Cont'd)

(7) Service Rearrangements (Cont'd)

All other service rearrangements will be charged for as follows:

- If the change involves the addition of another termination to an existing multipoint service, the Initial Ordering Charge - Special Access will apply plus the Service Installation charge for each location added.
- If the change involves the addition of supplemental feature or multiplexing arrangement, the Subsequent Ordering Charge - Special Access will apply plus the installation charge associated with the supplemental feature or arrangement.
- If the change involves only changing the type of network interface, with no change in facility, the Subsequent Ordering Charge - Special Access will apply per ASR for each customer designated location requiring a network interface change. In addition, an amount equal to one half of the Service Installation charge for each service requiring a network interface change will also apply.
- If the change involves changing a two-wire service to a four-wire service or vice versa, the Subsequent Ordering Charge - Special Access will apply plus the Service Installation charge for each location changed.

WN U-16
ZiPLY Fiber

Original Sheet 368

FACILITIES FOR INTRASTATE ACCESS

5. SPECIAL ACCESS (Cont'd)

5.6 Rate Regulations (Cont'd)

5.6.1 Types of Rates and Charges (Cont'd)

(D) Nonrecurring Charges (Cont'd)

(7) Service Rearrangements (Cont'd)

- If the change involves the retermination of an existing circuit within the wire center only, in association with the installation of high capacity facilities and/or multiplexing arrangements, the Subsequent Ordering Charge - Special Access will apply plus an amount equal to one half the Service Installation charge.
- If the change involves the retermination of an existing circuit within a wire center and a change in the facilities involved (i.e., reroute), in association with the installation of high capacity facilities and/or multiplexing arrangements, the Subsequent Ordering Charge - Special Access will apply plus the Service Installation charge for the location involved.
- In cases where multiple service rearrangements or an additional termination or a move and a service rearrangement are requested on a single ASR, the total charge will never exceed the full nonrecurring charge for the basic service.

WN U-16
Zipty Fiber

Original Sheet 369

FACILITIES FOR INTRASTATE ACCESS

5. SPECIAL ACCESS (Cont'd)

5.6 Rate Regulations (Cont'd)

5.6.2 Minimum Periods

Special Access is provided for a specified minimum period. Minimum periods and minimum period charges are described in Section 3.

5.6.3 Mileage Measurement

The mileage to be used to determine the monthly rate for the Special Transport is calculated on the airline distance between the serving wire centers involved (i.e., CDL serving wire center or Hub Wire Center or WATS Serving Office). Where the calculated miles include a fraction, the value is always rounded up to the next full mile. Where the calculated value is zero, no Special Transport mileage is charged.

When there is a Hub Wire Center involved, the Special Transport mileage will be measured from the Hub Wire Center to the serving wire centers of each of the CDLs connected to the hubbed facilities. Mileage is computed for each section and rates are applied accordingly. However, when a Special Access facility is routed through a Hub Wire Center for purposes other than customer specified such as bridging or multiplexing (e.g. the Telephone Company chooses to so route for test access purposes), rates will be applied only to the distance calculated between the wire centers serving the CDLs.

The rates for the mileage are applied per airline mile. The serving wire center V&H coordinates and the method of calculation are specified in the NECA Tariff FCC No. 4.

WN U-16
ZiPLY Fiber

Original Sheet 370

FACILITIES FOR INTRASTATE ACCESS

5. SPECIAL ACCESS (Cont'd)

5.6 Rate Regulations (Cont'd)

5.6.4 Moves

A move involves a change in the physical location of the point of termination of Special Access. A move normally involves an interruption of Special Access for the period required to complete the move. No credit allowance will be granted for that period. Special Construction in Section 10 may also be applicable at the different CDL. The charge for the move depends on whether the move is within the same CDL or to a different CDL.

A customer may request that Special Access not be interrupted during a move. To comply with that request, it may be necessary to install a duplicate Special Access, and subsequently discontinue the existing Special Access. Charges, monthly and nonrecurring, will apply for the duplicate Special Access. A new minimum period will be established for the duplicate portion of the Special Access, depending on which end of the Special Access is moved. The customer will remain responsible for all minimum period charges associated with the corresponding portion of the disconnected Special Access.

(A) Same CDL

When the move of a termination of FIA, as defined in Section 2.1.5, for Special Access is to a new point within the same CDL (same address and/or same building), the charge for the move will be the Subsequent Ordering Charge - Special Access plus an amount equal to one half the Service Installation charge for the service being reterminated. There will be no change in the minimum period requirements. For services subject to payment plan regulations, the same payment period will remain in force.

WN U-16
Zipty Fiber

Original Sheet 371

FACILITIES FOR INTRASTATE ACCESS

5. SPECIAL ACCESS (Cont'd)

5.6 Rate Regulations (Cont'd)

5.6.4 Moves (Cont'd)

(B) Different CDL

- (1) When the move is to a different CDL (different address and different building), except as specified below, it will be treated as a disconnect and an installation of service. The Initial Ordering Charge - Special Access will apply plus the Service Installation charge for the service termination(s) affected. Termination Liability will not be assessed if service is maintained for the remainder of the existing payment plan. See Termination Liability, Section 2.8.
- (2) When the move is to a different CDL but served by the same serving wire center, the following conditions apply:
 - A change ASR will be required.
 - Subsequent Ordering Charge - Special Access will apply plus the appropriate service installation charge for the service termination(s) affected.
 - For Special Access services subject to payment plan regulations, if the customer of record remains the same with no lapse in service, the Subsequent Ordering Charge - Special Access and appropriate NRCs apply. Otherwise, the move will be treated as a disconnect and an installation of service and all appropriate NRCs will be applicable. See Termination Liability, Section 2.8.

WN U-16
Zipty Fiber

Original Sheet 372

FACILITIES FOR INTRASTATE ACCESS

5. SPECIAL ACCESS (Cont'd)

5.6 Rate Regulations (Cont'd)

5.6.5 Rates and Charges on an Individual Case Basis

(A) The monthly/hourly rates and nonrecurring charges for the following service offerings will be developed on an Individual Case Basis:

- Full-time and Temporary (Part-time) Videoband Facilities
- Wideband Analog - Group Band Facilities
- Wideband Analog - Supergroup Band Facilities
- Wideband Analog - Mastergroup Band Facilities
- Wideband Data Facilities
- High Capacity Digital DS1C (3.152 Mbps) Special Access Lines
- High Capacity Digital DS3 Special Access Lines with optical interface
- High Capacity Digital DS3 Special Access Lines Group Systems
- High Capacity Digital DS3 Special Access Lines Unlimited System
- High Capacity Digital DS3C (89.472 Mbps) Facilities

WN U-16
Zipty Fiber

Original Sheet 373

FACILITIES FOR INTRASTATE ACCESS

5. SPECIAL ACCESS (Cont'd)

5.6 Rate Regulations (Cont'd)

5.6.5 Rates and Charges on an Individual Case Basis (Cont'd)

(B) The monthly rates and nonrecurring charges for the following Multiplexing Arrangements will be developed on an Individual Case Basis:

Group to Voice
Supergroup to Group
Mastergroup to Supergroup
DS3C to DS1
Group to DS1

5.6.6 Hub Wire Centers

A Hub Wire Center is a Telephone Company designated serving wire center at which bridging or multiplexing arrangements are provided. Bridging is used to connect three or more CDLs in a multipoint arrangement. The multiplexing arrangements channelize analog or digital facilities to individual services requiring a lower capacity or bandwidth.

Although Hub Wire Centers are defined as serving wire centers at which bridging or multiplexing arrangements are performed, they are not limited to providing these functions and may provide any other types of Special Access services offered in this tariff. For example, the Telephone Company will designate certain Hub Wire Centers for Program Audio Service offerings and the termination of Group System DS3 Special Transport.

WN U-16
Zipty Fiber

Original Sheet 374

FACILITIES FOR INTRASTATE ACCESS

5. SPECIAL ACCESS (Cont'd)

5.6 Rate Regulations (Cont'd)

5.6.6 Hub Wire Centers (Cont'd)

The Telephone Company will designate the Hub Wire Center locations. Different locations may be designated as Hub Wire Centers for different functions, such as bridging or multiplexing arrangements, for different facility capacities (e.g., multiplexing from digital to digital may occur at one wire center while multiplexing from digital to analog may occur at a different wire center). The location of Hub Wire Centers and the types of hubbing functions offered at that location are identified in the NECA Tariff FCC No. 4.

Some of the types of multiplexing provided include the following:

- from higher to lower bit rate,
- from higher to lower bandwidth,
- from digital to voice grade service.

The transmission performance for the end to end Special Access provided from CDLs will be that of the lower capacity or bit rate. For example, when a DS1 Special Access is multiplexed to voice frequency circuits, the transmission performance will be Voiceband, not High Capacity.

The Telephone Company will commence billing the monthly rate for the Special Access Line and Special Transport for the High Capacity facility to the Hub Wire Center as of the service date, even though individual services utilizing those facilities may not be installed until a later date. If the customer has designated the type of multiplexing to be provided with the High Capacity facility, the nonrecurring charge for the Multiplexing Arrangement will be billed to the customer at that same time, and the billing for the monthly rate will begin.

WN U-16
ZiPLY Fiber

Original Sheet 375

FACILITIES FOR INTRASTATE ACCESS

5. SPECIAL ACCESS (Cont'd)

5.6 Rate Regulations (Cont'd)

5.6.6 Hub Wire Centers (Cont'd)

Individual Special Access rates (by Special Access type) will apply for the Special Access Line and additional Special Transport facilities (if required) for each channelized Special Access. These will be billed to the customer as each individual Special Access is installed.

A customer may order full-time and/or part-time Program Audio Services between two CDLs, or between a CDL and a Hub Wire Center, and will be billed accordingly at the rates in Sections 5.7.

At the request of the customer, the full-time and/or part-time services provided to a Hub Wire Center may be connected together in the following configurations: full-time to full-time, full-time to part-time, or part-time to part-time.

The rates that apply for Program Audio Services between each CDL and the Hub Wire Center are Special Transport, if applicable, and Special Access Line. In addition, rates for Supplemental Features and Inside Wiring may be applicable.

5.6.7 Shared Use Analog and Digital High Capacity Services

(A) Monthly charges for a DS1 or DS3 high capacity shared use facility will be apportioned between Switched and Special Access based on the relative proportion of channels used for switched and special access in the following manner.

If the facility is ordered as Special Access, rating as Special Access will continue until such time as a portion of the available capacity is used to provide Switched Access service. As individual channels are activated for Switched Access, monthly charges will be apportioned between Switched and Special Access based on the number of channels used for Switched Access and the number of remaining channels on the Special Access facility according to the following formula:

WN U-16
Zipty Fiber

Original Sheet 376

FACILITIES FOR INTRASTATE ACCESS

5. SPECIAL ACCESS (Cont'd)

5.6 Rate Regulations (Cont'd)

5.6.7 Shared Use Analog and Digital High Capacity Services (Cont'd)

(A) (Cont'd)

- The total shared use charge is equal to the Monthly Switched Access Charge times the number of channels used for Switched Access divided by 24 for DS1 or 672 for DS3 plus the monthly Special Access Charge times the number of channels remaining for Special Access divided by 24 for DS1 or 672 for DS3.

If the facility is ordered as Switched Access, rating as Switched Access will continue until such time as a portion of the available capacity is used to provide Special Access service. As individual channels are activated for Special Access, monthly charges will be apportioned between Switched and Special Access based on the number of channels used for Special Access and the number of remaining channels on the Switched Access Facility according to the following formula:

- The total shared use charge is equal to the Monthly Special Access divided by 24 for DS1 or 672 for DS3 plus the monthly Switched Access Charge times the number of channels remaining for Switched Access divided by 24 for DS1 or 672 for DS3.

The monthly Switched and Special Access rate used will be the appropriate rate (Special Access SAL, Special Transport and Multiplexer and Switched Transport Entrance Facility, Direct-Trunked Transport and Multiplexer) for the underlying shared use facility, i.e., if the underlying facility is a Special Access DS3 service, the corresponding Switched Access DS3 Transport will be used to determine the Switched Access monthly charges.

Shared use of FiberConnect Service, when feasible, will be addressed on a case by case basis.

5.6.8 Temporary Videoband Service

The rates and charges for use of facilities for Temporary Videoband Service are assessed on a per hop basis. A hop is defined as the transporting of a one-way video and associated audio signal(s) in a direct path from a transmitter location to the adjacent receiver location. The distance of a single hop is primarily a factor of the local geographics of the video path, therefore, more than one hop may be required between CDLs.

WN U-16
Zipty Fiber

Original Sheet 377

FACILITIES FOR INTRASTATE ACCESS

5. SPECIAL ACCESS (Cont'd)

5.6 Rate Regulations (Cont'd)

5.6.8 Temporary Videoband Service (Cont'd)

(A) Use of Nonpermanent Facilities for Temporary Videoband Service

Temporary Videoband Service is provided by nonpermanent facilities.

Nonpermanent facilities consist of portable microwave equipment (e.g., transmitter, receiver, antenna, connecting cables and associated equipment) which is set up for the broadcast and subsequently removed after the broadcast.

The rates and charges for Temporary Videoband Service provided over nonpermanent facilities are developed on an Individual Case Basis.

(B) Joint Provisioning of Service

Where more than one Telephone Company is involved in the provisioning of a Temporary Videoband Service, such jointly provided facilities are subject to the rules and regulations outlined in Section 3.3 (Single Company and Multiple Company Billing). The rates for the Video nonbroadcast will be one-half the nonrecurring charge and one-half the hourly charge for the facilities used to provide the service where multiple company billing is applicable. The rates for the Video nonbroadcast, where single company billing is applicable, are the entire nonrecurring charge and the entire hourly charge for the facilities used to provide the service.

WN U-16
Zipty Fiber

Original Sheet 378

FACILITIES FOR INTRASTATE ACCESS

5. SPECIAL ACCESS (Cont'd)

5.6 Rate Regulations (Cont'd)

5.6.9 High Voltage Protection

(A) Description

High Voltage Protection Service is used at customer locations that may require special equipment to isolate or neutralize Ground Potential Rise (GPR) and/or induced voltage caused by faults in the electric power system. GPR is a voltage difference between two or more ground electrodes caused by earth return currents. GPR on cable facilities can occur when current from lightning surges flow to ground, but GPR often is associated with voltage generated as the power system fault currents flow to ground. Maximum GPR is developed by the percentage of line-to-ground fault current entering earth through electrode impedance.

This feature will provide high voltage isolation for Special Access telecommunications, while enabling the normal transmission between the Telephone Company wire center and the equipment at the customer's location during a GPR environment due to electrical power faults.

(B) Provisioning

The Telephone Company shall determine the proper levels of protection required on its network to isolate or neutralize electrical hazard, based on the information provided by the customer. The customer shall provide the Telephone Company, in writing, the technical data necessary for the Telephone Company to determine the high voltage protection requirements, at the time of application for the initial service, additions to, or changes in the existing service. In addition, the customer shall notify the Telephone Company before making changes in the electric supply that will increase the GPR at the location.

The technical data for the customer's location shall include, but not be limited to, the following:

- ground grid area in square feet
- ground grid impedance in Ohms
- X/R ratio at worst case fault location
- GPR in volts MS

WN U-16
Zipty Fiber

Original Sheet 379

FACILITIES FOR INTRASTATE ACCESS

5. SPECIAL ACCESS (Cont'd)

5.6 Rate Regulations (Cont'd)

5.6.9 High Voltage Protection (Cont'd)

(B) Provisioning (Cont'd)

Based on the customer's technical data provided to the Telephone Company, the Telephone Company will provide the necessary high voltage protection equipment at the Telephone Company's demarcation point on the customer's premises and at the remote drainage location. The placement of the equipment by the Telephone Company shall in no way release the customer of their responsibility for damage, loss or claims caused by electrical hazards resulting from the customer's electric power system. The Telephone Company's liability for damage, loss or claims is set forth under 2.1.3.

The customer may elect to furnish the equipment at its premises to isolate or neutralize the electrical hazard subject to the approval of the Telephone Company; however, such approval by the Telephone Company shall not relieve the customer of their responsibility to install or maintain adequate high voltage equipment. The high voltage protection equipment at the customer's location will be exclusively owned either by the Telephone Company or by the customer.

When the customer provides the high voltage equipment at its premise, the Telephone Company will provide the necessary high voltage equipment at the wire center and remote drainage location. The Telephone Company will be responsible up to and including the network interface for the termination of Special Access Services regardless of ownership of the high voltage protection equipment.

The Telephone Company will inspect and verify adequacy of the high voltage protection equipment when service is established and at such future times as deemed necessary due to additions, deletions, rearrangements, routine maintenance or for the purpose of verifying the adequacy of the high voltage protection equipment.

WN U-16
Zipty Fiber

Original Sheet 380

FACILITIES FOR INTRASTATE ACCESS

5. SPECIAL ACCESS (Cont'd)

5.6 Rate Regulations (Cont'd)

5.6.9 High Voltage Protection (Cont'd)

(C) Claims and Demands for Damage

In addition to the provisions in Section 2.3.10, the customer shall defend, indemnify and save harmless the Telephone Company from any and all loss, claims, demands, suits or other action or any liability whatsoever, whether suffered, made, instituted or asserted by the customer or by any other party or person, for any personal injury to or death of any person or persons, or for any loss, damage or destruction of any property whether owned by the customer or others, caused or claimed to have been caused directly or indirectly by the installation, operation, failure to operate, maintenance, removal, presence, condition, location or use of such equipment and services associated with high voltage protection equipment furnished by the Telephone Company or with customer equipment when combined or connected to facilities of the Telephone Company.

Services provided by the Telephone Company shall not cause the Telephone Company to become responsible for damage, loss or claims caused by electrical hazards resulting from a customer's electric power system.

(D) Network Outage

Interruptions or outages of services provided to customers may occur for reasons, such as facility damage due to storm loading, vehicle accident, lightning strike, or other acts of God. Circuit failures caused by such events cannot be prevented by services provided in accordance with this service. However, interruptions and service outages due to fault-produced ground potential rise and induction can and should be minimized. The Telephone Company expressly states that provision of the high voltage equipment cannot prevent such service outages as may normally occur due to the preceding circumstances. It is the responsibility of the customer to provide sufficient protection to prevent damage caused by such events.

Interruptions or outages due to the effects of GPR and/or induction of faults in the customer's power generating, transmission and/or distribution system are minimized through the installation and maintenance of high voltage protection equipment which is designed to operate in a fault-produced electrical environment.

WN U-16
Zipty Fiber

Original Sheet 381

FACILITIES FOR INTRASTATE ACCESS

5. SPECIAL ACCESS (Cont'd)

5.6 Rate Regulations (Cont'd)

5.6.9 High Voltage Protection (Cont'd)

(E) Compliance Statement

The Telephone Company reserves the right to disconnect service 120 days after giving the required notice, as set forth under Section 2.1.8(A), due to the following conditions:

- (1) The customer-provided equipment is nonfunctional or inadequate.
- (2) The customer fails, upon written notice, to establish or reestablish the required high voltage protection equipment or apply for and obtain such protection from the Telephone Company.
- (3) The customer fails to keep the Telephone Company informed of changed high voltage requirements.

(F) Rate Regulations

(1) Minimum Period

The minimum period for High Voltage Protection is one month.

(2) Rate Elements

(a) Initial Common Equipment

A nonrecurring charge and a monthly rate apply for the Initial Common (basic) Equipment used for the physical connection to the network interface. The Initial Common Equipment can accommodate up to eight Special Access facility terminations at a customer's location.

(b) Terminating Equipment

High Voltage Terminating Equipment is required for each Special Access facility termination. A nonrecurring charge and a monthly rate for the High Voltage Terminating Equipment apply in addition to the rates and charges for the Special Access facility as well as the associated Special Access Service regulations.

WN U-16
ZiPLY Fiber

Original Sheet 382

FACILITIES FOR INTRASTATE ACCESS

5. SPECIAL ACCESS (Cont'd)

5.6 Rate Regulations (Cont'd)

5.6.10 Metro Ethernet Special Transport

(A) Description

Metro Ethernet Special Transport (Metro Ethernet) provides DS1 transport between two or more serving wire centers located on a Telephone Company fiber optic ring. Metro Ethernet transport is provided at a flat-rate per month charge per DS1 Special Access transport facility, regardless of the number of miles the circuit is routed on the fiber ring. The charge for Metro Ethernet Special Transport is found in 5.7.7(C)

(B) Conversion of Existing DS1 Transport

Current DS1 Special Access transport can be replaced by Metro Ethernet. Where access to Metro Ethernet is made via a multiplexing arrangement in a central office on the fiber ring (i.e., DS3 to DS1, or Voiceband to DS1), the Metro Ethernet Month-to-Month rate will apply. Customers with Month-to-Month DS1 SALs will apply the Month-to-Month Metro Ethernet Rate.

(C) Discontinuance of Service

If a Month-to-Month DS1 SAL is discontinued, DS1 transport for the Metro Ethernet transport portion of the circuit is also discontinued.

Metro Ethernet transport may be converted to standard DS1 special transport rates (i.e., per airline mile) at any time at no charge.

WN U-16
ZiPLY Fiber

Original Sheet 383

FACILITIES FOR INTRASTATE ACCESS

5. SPECIAL ACCESS (Cont'd)

5.6 Rate Regulations (Cont'd)

5.6.10 Metro Ethernet Special Transport (Cont'd)

(D) Continuation of Service Off the Ring

Metro Ethernet DS1 circuits can be routed any distance on a fiber optic ring. When the DS1 circuit leaves the ring for continuation on the network, normal tariff rates will be assessed for the portion of the route not on the ring.

(E) Service Availability

Metro Ethernet DS1 transport is available to all DS1 customers in the Telephone Company serving area in which fiber optic rings are deployed. Metro Ethernet is provided between serving wire centers located on the same fiber optic ring within the following Telephone Company metropolitan serving area:

Metropolitan Serving Area

Everett

Eastside (Bothell/Kirkland)

Tri-Cities

WN U-16
Zipty Fiber

Original Sheet 384

FACILITIES FOR INTRASTATE ACCESS

5. SPECIAL ACCESS (Cont'd)

5.6 Rate Regulations (Cont'd)

5.6.11 DS3 High Capacity Service

(A) DS3 Rate Structure

Option 1: System DS3

System DS3 SALs are provided as a system offering. The interface provided is electrical. Additional SALs may only be added with the same interface as the First System. All DS3 SALs are non-distance sensitive.

Under a 3 System DS3, additional DS3 SALs, up to a maximum of two, may be ordered by the same customer, between the same CDL and serving wire center.

Option 2: Individual DS3

This option provides individual DS3 service. Before confirming the ASR for this option, the Telephone Company will verify the availability of a DS3 interface at the CDL. If a DS3 interface can be made available with no physical change to the existing configuration at the CDL, the ASR will be confirmed and processed. If this condition is not met, the customer will be advised and no charge will be assessed for the unprocessed ASR. The customer may then cancel the ASR or submit a new ASR for one of the services available under Option 1.

SAL rates for Individual DS3s vary dependent on whether the interface provided is electrical or optical.

Option 1, 3 System DS3s and Option 2, Individual DS3s may be ordered as protected SALs with an electrical interface. A protected DS3 SAL provides a spare transmission path (transmit and receive) connected to an automatic protection switch. In the event of failure in the primary service, traffic will be automatically transferred to the spare transmission facilities. The spare transmission path will normally be provided on the same route as the primary path. When a customer orders a protected DS3 SAL, the customer may request that the spare transmission path be provided via an alternate route provisioned as the Telephone Company may elect. If common points for the primary and alternate route become necessary, these points will be identified by the Telephone Company and provided to the ordering customer. Should the routing arrangement require special routing requirements specified by the customer, other rates and regulations as described in Section 9 or Section 10 may be applicable.

Issued: July 29, 2020
Issued by Zipty Fiber
By Jessica Epley, Regulatory & External Affairs Director

Effective: July 31, 2020

WN U-16
Zipty Fiber

Original Sheet 385

FACILITIES FOR INTRASTATE ACCESS

5. SPECIAL ACCESS (Cont'd)

5.6 Rate Regulations (Cont'd)

5.6.11 DS3 High Capacity Service (Cont'd)

(A) DS3 Rate Structure (Cont'd)

A customer may order the same or different type of DS3 SALs for each CDL(s) at which DS3 service is terminated.

When a customer requests the disconnect of a DS3 service in the 3 System DS3, an Additional System DS3 SAL must be disconnected first. When only the First DS3 service exists, that service will be disconnected.

Any costs associated with Special Construction as specified in Section 10 will apply.

DS3 Special Transport contains two rate elements, Special Transport Termination and Special Transport Facility. Special Transport Termination rates apply for the termination of each end of the interoffice facility. Special Transport Facility rates apply for each airline mile of the interoffice facility.

WN U-16
ZiPLY Fiber

Original Sheet 386

FACILITIES FOR INTRASTATE ACCESS

5. SPECIAL ACCESS (Cont'd)

5.6 Rate Regulations (Cont'd)

5.6.11 DS3 High Capacity Service (Cont'd)

(B) Minimum Service Period

Individual DS3s and System DS3s are offered under four minimum service periods, each with different rate levels. The minimum service periods are 1, 3, 5 and 7 years. The customer must specify the minimum service period at the time the service is ordered. First and Additional DS3 SALs (3 System DS3s) can have a different minimum service period. However, each DS3 SAL of a two-point DS3 service must have the same minimum service period.

The customer may select a longer minimum service period at any time, without penalty or application of nonrecurring charges, to obtain the lower monthly recurring rates associated with a longer minimum service period. When the customer selects this option, they will receive full credit for the amount of time they were under the shorter minimum service period. For example, if a customer ordered a one year minimum service period, then decided after six months to change to a three year minimum service period, he will have a remaining obligation of 30 months. The new recurring charges will apply subsequent to the effective date of the new minimum service period.

(C) Expiration of Minimum Service Period

See Termination Liability, Section 2.8.3, for Renewal Options.

When a customer retains DS3 service(s) for the duration of a minimum service period, the termination liabilities expire. As long as the customer makes no physical changes to the configuration of service(s), the customer will no longer be liable for early termination discontinuance charges regardless of the minimum service period rate level. Should a customer choose to disconnect a DS3 service having satisfied the minimum service period termination liabilities, the disconnect steps will still be applied as specified in 5.6.11(A).

(D) Discontinuance Without Liability - DS3 Minimum Service Period

Should the recurring charges for a customer's DS3 service increase, in aggregate, by more than 10% from the original recurring charges during the minimum service period, the customer may, at their option, terminate the DS3 service without penalty or liability.

(E) Discontinuance With Liability - DS3 Minimum Service Period

If DS3 service is discontinued prior to the end of the minimum service period, the customer will be liable for termination charges as set forth in Termination Liability, Section 2.8.

WN U-16
Zipty Fiber

Original Sheet 387

FACILITIES FOR INTRASTATE ACCESS

5. SPECIAL ACCESS (Cont'd)

5.6 Rate Regulations (Cont'd)

5.6.11 DS3 High Capacity Service (Cont'd)

(F) Notification of Discontinuance

Notice of discontinuance must be given by the customer at least thirty days prior to actual discontinuance. Monthly charges will apply for a period of thirty days from the date the Company receives discontinuance notification or until the requested discontinuance date, whichever period is longer.

(G) DS3 Multiplexer Cross Connect Arrangement

For DS3 multiplexed services, the DS3 Multiplexer Cross Connect arrangement allows a customer to cross connect digital DS1 channels from one multiplexer to another multiplexer. The rate as specified in 5.7.16 will apply per cross connect arrangement. If the DS3 multiplexed services are located in different hub wire centers, DS1 special transport will apply in addition to the DS1 cross connect charge. The customer must provide the channel assignments (CFA and SCFA) for both multiplexed services on the ASR.

WN U-16
ZiPLY Fiber

Original Sheet 388

FACILITIES FOR INTRASTATE ACCESS

5. SPECIAL ACCESS (Cont'd)

5.6 Rate Regulations (Cont'd)

5.6.12 Optional Payment Plan (OPP) for FT1, FiberConnect and DDS

(A) General

- (1) The terms and conditions specified herein are applicable to FT1, FiberConnect and DDS services. Additional terms and conditions for DDS are found in 5.6.12(f). Fractional T1 is limited to those services so equipped and in service as of September 3, 1996.
- (2) Only the Special Access Line (SAL) rate element is available under an OPP. All other associated rate elements or additional features are available at the standard month-to-month tariffed rates and regulations.
- (3) FT1 OPP SAL rates will not be greater than standard month-to-month SAL rates. FiberConnect is not available on a month-to-month basis.
- (4) Three and five year OPP rates will be equal to or less than the one year OPP rates. Decreases to the one-year OPP will flow through to the three and five year OPP.
- (5) Payment periods of one, three and five years are available to all customers at the applicable rates in 5.7.15(C) regardless of when they subscribe to an OPP arrangement.

WN U-16
Zipty Fiber

Original Sheet 389

FACILITIES FOR INTRASTATE ACCESS

5. SPECIAL ACCESS (Cont'd)

5.6 Rate Regulations (Cont'd)

5.6.12 Optional Payment Plan (OPP) for FT1, FiberConnect and DDS (Cont'd)

(A) General (Cont'd)

- (6) The customer must designate on the ASR the payment period for the OPP.
- (7) Inside moves, provided in accordance with 5.6.4, will not incur termination liability charges.
- (8) Outside moves provided in accordance with 5.6.4 (B) (2) will allow the customer to retain the same OPP payment period. Any other move will be treated as a disconnection of the service and termination liability charges as outlined in 2.8.4 will apply.

(B) Changes in Length of OPP Period

Prior to the completion of the selected OPP period, the customer may elect to convert to a new OPP period of the same or different length, subject to the following conditions:

- No credit toward the new payment period will be given for payments made under the original OPP arrangement.
- Nonrecurring charges will not be reapplied for existing service(s).
- If the new OPP period is shorter in length than the time remaining under the existing OPP, the change to the new OPP period constitutes a disconnect of the existing OPP service and termination liability charges will apply as outlined in Section 2.8, Termination Liability.

WN U-16
ZiPLY Fiber

Original Sheet 390

FACILITIES FOR INTRASTATE ACCESS

5. SPECIAL ACCESS (Cont'd)

5.6 Rate Regulations (Cont'd)

5.6.12 Optional Payment Plan (OPP) for FT1, FiberConnect and DDS (Cont'd)

(C) Renewal Options

- (1) For renewal options, see Section 2.8.3, under Termination Liability.
- (2) Conversion to a different OPP period will require the customer to submit a change order ASR. Conversion to a different OPP period will be allowed without application of any nonrecurring or ordering charges.
- (3) Conversion to month-to-month rates will be treated as a disconnection of service and establishment of new service. If no other changes are ordered, only the Initial Ordering Charge-Special Access will apply per required ASR.

(D) Notification of Discontinuance

An ASR to discontinue an OPP arrangement must be received by the Telephone Company at least thirty (30) days prior to actual disconnection of service. Monthly charges will apply for a period of thirty (30) days from the date the Telephone Company receives disconnect notification or until the requested disconnect date, whichever is longer.

WN U-16
ZiPLY Fiber

Original Sheet 391

FACILITIES FOR INTRASTATE ACCESS

5. SPECIAL ACCESS (Cont'd)

5.6 Rate Regulations (Cont'd)

5.6.12 Optional Payment Plan (OPP) for FT1, FiberConnect and DDS (Cont'd)

(E) Upgrade to Higher Speed Service

Customers may elect to upgrade service(s) to a higher speed during an OPP period, subject to the following conditions:

- The upgraded service will be subject to all appropriate nonrecurring charges.
- Termination liability charges will not apply as long as the upgraded service remains connected at the same point of termination(s) or meets the requirements in 5.6.4(B)(2).
- See Section 2.8.4 for exceptions to Termination Liability.

(F) Termination Liability

When an OPP service is discontinued prior to the end of the period, termination liability charges as set forth in Section 2.8 under Termination Liability will apply.

(G) OPP for DDS

- (1) For conversion of existing month-to-month DDS to an OPP arrangement, the customer will be required to submit a change order ASR to convert to the OPP. No service or billing interruption will occur when a customer converts from month-to-month rates to OPP rates. If no other changes to the service are ordered, no charge will apply.

WN U-16
Zipty Fiber

Original Sheet 392

FACILITIES FOR INTRASTATE ACCESS

5. SPECIAL ACCESS (Cont'd)

5.6 Rate Regulations (Cont'd)

5.6.13 Optional Payment Plan (OPP) for DS1

(A) General

- (1) The terms and conditions specified herein are applicable to DS1 services.
- (2) Only the Special Access Line (SAL) rate element is available under an OPP. All other associated rate elements or additional features are available at the standard month-to-month tariffed rates and regulations.
- (3) Nonrecurring charges are not applicable for DS1 services subscribed to under an Optional Payment Plan.
- (4) DS1 OPP SAL rates will not be greater than standard month-to-month SAL rates plus applicable nonrecurring charges.
- (5) Three and five year OPP rates will be equal to or less than the one year OPP rates.
- (6) Payment periods of one, three and five years are available to all customers at the applicable rates in 5.7 following.
- (7) The customer must designate on the ASR the payment period for the OPP.

FACILITIES FOR INTRASTATE ACCESS

5. SPECIAL ACCESS (Cont'd)

5.6 Rate Regulations (Cont'd)

5.6.13 Optional Payment Plan (OPP) for DS1 (Cont'd)

(B) Conditions

- (1) Under the DS1 OPP rate structure, there is no distinction between first and additional systems. The DS1 Standard Arrangement in 5.7.7(A) does not apply.
- (2) Installation charges do not apply to initial or subsequent DS1 services ordered under the OPP.
- (3) Under an OPP arrangement, the same customer can order DS1 service from their CDL to different terminating CDLs.
- (4) The terms for first and additional systems do not need to be coterminous.

(C) Moves

See Section 2.8, Termination Liability.

(D) Changes in Length of OPP Period

Prior to the completion of the selected OPP period, the customer may elect to convert to a new OPP period of the same or different length, subject to the following conditions:

- (1) No credit toward the new payment period will be given for payments made under the original OPP arrangement.
- (2) If the new OPP period is shorter in length than the time remaining under the existing OPP, termination liability charges will apply as outlined in Section 2.8, Termination Liability.

WN U-16
Zipty Fiber

Original Sheet 394

FACILITIES FOR INTRASTATE ACCESS

5. SPECIAL ACCESS (Cont'd)

5.6 Rate Regulations (Cont'd)

5.6.13 Optional Payment Plan (OPP) for DS1 (Cont'd)

(E) Renewal Options

(1) For renewal options, see Section 2.8.3, under Termination Liability.

(2) Conversion to a different OPP period will require the customer to submit a change order ASR. Conversion to a different OPP period will be allowed without application of any nonrecurring or ordering charges.

(3) Conversion to month-to-month rates will be treated as a disconnection of service and establishment of new service. If no other changes are ordered, only the Initial Ordering Charge-Special Access will apply per required ASR.

(F) Notification of Discontinuance

An ASR to discontinue an OPP arrangement must be received by the Telephone Company at least thirty (30) days prior to actual disconnection of service. Monthly charges will apply for a period of thirty (30) days from the date the Telephone Company receives disconnect notification or until the requested disconnect date, whichever is longer.

(G) Upgrade to Higher Speed Service

Customers may elect to upgrade service(s) to a higher speed during an OPP period, subject to the conditions in Section 2.8.4, Termination Liability.

(H) Termination Liability

When an OPP service is discontinued prior to the end of the period, termination liability charges as set forth in Section 2.8 under Termination Liability will apply.

WN U-16
Zipty Fiber

Original Sheet 395

FACILITIES FOR INTRASTATE ACCESS

5. SPECIAL ACCESS (Cont'd)

5.7 Rates and Charges

Nonrecurring
Charge

5.7.1 Special Access Ordering Charges

Initial Ordering Charge Special Access	\$117.42
Subsequent Ordering Charge Special Access	64.40
Service Installation Charge per SAL	174.61
Design Change Charge per ASR/Per Occurrence	40.96
Temporary Videoband Service	ICB

WN U-16
Zipty Fiber

Original Sheet 396

FACILITIES FOR INTRASTATE ACCESS

5. SPECIAL ACCESS (Cont'd)

5.7 Rates and Charges (Cont'd)

5.7.2 Voiceband Facilities

(A) <u>Standard Arrangements</u>	<u>Nonrecurring Charges</u>	<u>Monthly Rate</u>
Special Transport, per airline mile*	--	\$4.45
Special Access Line		
Two-Wire		17.50
Four -Wire	--	26.50

* Rate also applicable for Intraexchange Interoffice mileage.

Issued: July 29, 2020
Issued by Zipty Fiber
By Jessica Epley, Regulatory & External Affairs Director

Effective: July 31, 2020

WN U-16
ZiPLY Fiber

Original Sheet 397

FACILITIES FOR INTRASTATE ACCESS

5. SPECIAL ACCESS (Cont'd)

5.7 Rates and Charges (Cont'd)

5.7.2 Voiceband Facilities (Cont'd)

(B) <u>Optional Arrangements</u>	<u>Nonrecurring Charges</u>	<u>Monthly Rate</u>
Supplemental Features, per Port		
Multi-point Data Bridging	--	\$5.46
Voice Conference Bridging	\$5.00	4.40
Alarm Distribution Bridging		
Common Equipment	--	1.00
per Two-Wire Port	--	1.00
Conditioning Arrangements - Data		
Type C	66.00	3.20
Type DA	--	4.29

WN U-16
Zipty Fiber

Original Sheet 398

FACILITIES FOR INTRASTATE ACCESS

5. SPECIAL ACCESS (Cont'd)

5.7 Rates and Charges (Cont'd)

5.7.2 Voiceband Facilities (Cont'd)

(B) <u>Optional Arrangements</u> (Cont'd)	<u>Nonrecurring Charges</u>	<u>Monthly Rate</u>
Supplemental Features		
Signaling Arrangement/per SAL		
Loop Signaling Range Extension	\$170.94	\$5.90
Loop or E&M to SF	274.22	13.82
E&M to DX	170.94	6.57
E&M to Loop	191.84	4.68
Loop or E&M to PCM	136.81	2.79
Automatic Ringdown	40.00	15.51
Echo Control - Echo Suppression/per CKT	215.34	12.41
Echo Control - Echo Canceller/per CKT	265.76	23.58
Voiceband Facility Switching Arrangement	170.94	2.87

WN U-16
Zipty Fiber

Original Sheet 399

FACILITIES FOR INTRASTATE ACCESS

5. SPECIAL ACCESS (Cont'd)

5.7 Rates and Charges (Cont'd)

5.7.2 Voiceband Facilities (Cont'd)

(B) <u>Optional Arrangements</u> (Cont'd)	<u>Nonrecurring Charges</u>	<u>Monthly Rate</u>
Supplemental Features (Cont'd)		
Dataphone Select-a-station Bridging Common Equipment		
Addressable	\$2,872.90	\$165.35
Sequential	--	6.00
Each Four-Wire Port	166.33	11.37
Each Two-Wire Port	--	2.80
Improved Return Loss/per SAL	27.00	1.91
Improved Termination Option/per SAL	136.37	7.10
Improved ELEPL/per SAL	104.32	2.17

WN U-16
Zipty Fiber

Original Sheet 400

FACILITIES FOR INTRASTATE ACCESS

5. SPECIAL ACCESS (Cont'd)

5.7 Rates and Charges (Cont'd)

5.7.3 Program Audio (200-3500 Hz) Facilities

(A) <u>Standard Arrangements</u>	<u>Nonrecurring Charges</u>	<u>Monthly Rate</u>	<u>Daily Rate</u>
Special Transport, per airline mile*	--	\$4.45	\$.45
Special Access Line	--	32.15	3.22
(B) <u>Optional Arrangements</u>			
Supplemental Features			
Program Audio Bridging/per Port	\$28.39	2.11	.21
Conditioning - Program Audio-Zero Loss/per SAL	260.81	16.76	1.68

* Rate also applicable for Intraexchange Interoffice mileage.

WN U-16
Zipty Fiber

Original Sheet 401

FACILITIES FOR INTRASTATE ACCESS

5. SPECIAL ACCESS (Cont'd)

5.7 Rates and Charges (Cont'd)

5.7.4 Program Audio (100-5000 Hz) Facilities

(A) <u>Standard Arrangements</u>	<u>Nonrecurring Charges</u>	<u>Monthly Rate</u>	<u>Daily Rate</u>
Special Transport, per airline mile*	--	\$12.47	\$1.25
Special Access Line	--	51.48	5.15
(B) <u>Optional Arrangements</u>			
Supplemental Features			
Program Audio Bridging/per Port	\$28.39	2.11	.21
Conditioning - Program Audio-Zero Loss/per SAL	260.81	16.76	1.68

* Rate also applicable for Intraexchange Interoffice Mileage.

WN U-16
ZiPLY Fiber

Original Sheet 402

FACILITIES FOR INTRASTATE ACCESS

5. SPECIAL ACCESS (Cont'd)

5.7 Rates and Charges (Cont'd)

5.7.5 Program Audio (50-8000 Hz) Facilities

(A) <u>Standard Arrangements</u>	<u>Nonrecurring Charges</u>	<u>Monthly Rate</u>	<u>Daily Rate</u>
Special Transport, per airline mile*	--	\$15.60	\$1.56
Special Access Line	--	52.70	5.27
(B) <u>Optional Arrangements</u>			
Supplemental Features			
Program Audio Bridging/per Port	\$28.39	2.11	.21
Conditioning – Program Audio-Zero Loss/per SAL	260.81	16.76	1.68

* Rate also applicable for Intraexchange Interoffice Mileage.

WN U-16
Zipty Fiber

Original Sheet 403

FACILITIES FOR INTRASTATE ACCESS

5. SPECIAL ACCESS (Cont'd)

5.7 Rates and Charges (Cont'd)

5.7.6 Program Audio (50-15000 Hz) Facilities

(A) <u>Standard Arrangements</u>	<u>Nonrecurring Charges</u>	<u>Monthly Rate</u>	<u>Daily Rate</u>
Special Transport, per airline mile*	--	\$18.70	\$1.87
Special Access Line	--	77.33	7.73
 (B) <u>Optional Arrangements</u>			
Supplemental Features			
Program Audio Bridging/per Port	\$28.39	2.11	.21
Conditioning - Program Audio-Stereo Conditioning/per SAL	129.13	1.04	.10
Conditioning - Program Audio-Zero Loss/per SAL	260.81	16.76	1.68

* Rate also applicable for Intraexchange Interoffice mileage.

WN U-16
Zipty Fiber

Original Sheet 404

FACILITIES FOR INTRASTATE ACCESS

5. SPECIAL ACCESS (Cont'd)

5.7 Rates and Charges (Cont'd)

5.7.7 High Capacity Digital DS1 (1.544 Mbps) Facilities

(A) <u>Standard Arrangements</u>	<u>Nonrecurring Charges</u>	<u>Monthly Rate</u>
Special Access Line		
First System	\$320.00	\$150.00
Each Additional System	320.00	142.50
Special Transport Termination	--	75.00
Special Transport, per airline mile ¹	--	11.00

¹ Rate also applicable for Intraexchange Interoffice mileage.

WN U-16
ZiPLY Fiber

Original Sheet 405
05

FACILITIES FOR INTRASTATE ACCESS

5. SPECIAL ACCESS (Cont'd)

5.7 Rates and Charges (Continued)

5.7.7 High Capacity Digital DS1 (1.544 Mbps) Facilities

(B) <u>Optional Payment Plan (OPP)</u>	<u>Nonrecurring Charges</u>	<u>Monthly Rate</u>
Special Access Line, First and Additional Systems		
One Year Term Commitment	--	\$177.00
Three Year Term Commitment	--	152.00
Five Year Term Commitment	--	140.00
Special Transport Termination	--	75.00
Special Transport, per air line mile ¹	--	11.00
(C) <u>Optional Arrangements</u>		
Supplemental Features, per Special Access		
Automatic Protection Switching	1,467.15	106.96
Metro Ethernet-Special Transport, per DS1	--	75.00

¹ Rate also applicable for Intraexchange Interoffice mileage.

WN U-16
Zipty Fiber

Original Sheet 406

FACILITIES FOR INTRASTATE ACCESS

5. SPECIAL ACCESS (Cont'd)

5.7 Rates and Charges (Cont'd)

5.7.8 High Capacity Digital DS1C (3.152 Mbps) Facilities

(A) <u>Standard Arrangements</u>	<u>Nonrecurring Charges</u>	<u>Monthly Rate</u>
Special Transport Termination	--	\$19.13
Special Transport, per airline mile*	--	28.78

* Rate also applicable to Intraexchange Interoffice mileage.

Issued: July 29, 2020
Issued by Zipty Fiber
By Jessica Epley, Regulatory & External Affairs Director

Effective: July 31, 2020

WN U-16
ZiPLY Fiber

Original Sheet 407

FACILITIES FOR INTRASTATE ACCESS

5. SPECIAL ACCESS (Cont'd)

5.7 Rates and Charges (Cont'd)

5.7.9 High Capacity FiberConnect (6.312 Mbps) Facilities

	<u>Nonrecurring Charges</u>	<u>Monthly Rate</u>
FiberConnect Optional Payment Plan		
Special Transport, Per Airline Mile	--	1
Special Transport Termination	--	1
Special Access Line -		
(A) Electrical Interface	\$1,000.00	
One Year	--	\$1,100.00
Three Year	--	800.00
Five Year	--	650.00

¹ In addition to the DS1 Special Transport and Special Transport Termination rate elements (when applicable) in 5.7.7 for four DS1 transported circuits.

WN U-16
ZiPLY Fiber

Original Sheet 408

FACILITIES FOR INTRASTATE ACCESS

5. SPECIAL ACCESS (Cont'd)

5.7 Rates and Charges (Cont'd)

5.7.9 High Capacity FiberConnect (6.312 Mbps) Facilities (Cont'd)

	<u>Nonrecurring Charges</u>	<u>Monthly Rate</u>
(B) Optical Interface	\$1,000.00	
One Year	--	\$850.00
Three Year	--	550.00
Five Year	--	475.00

WN U-16
Zipty Fiber

Original Sheet 409

FACILITIES FOR INTRASTATE ACCESS

5. SPECIAL ACCESS (Cont'd)

5.7 Rates and Charges (Cont'd)

5.7.10 High Capacity Digital Fractional T1 (FT1) Facilities¹

		<u>Nonrecurring Monthly Charges</u>	<u>Rate</u>
(A)	<u>Standard Arrangements</u>		
(1)	2 x 56 Kbps or 2 x 64 Kbps Special Access Line	\$450.00	\$103.78
	Special Transport, per airline mile ²	--	5.50
	Special Transport Termination	--	12.00
(2)	4 x 56 Kbps or 4 x 64 Kbps Special Access Line	450.00	111.59
	Special Transport per airline mile ²	--	6.50
	Special Transport Termination	--	18.00

¹ Limited to those services so equipped and in service as of September 3, 1996.

² Rate also applicable for Intraexchange Interoffice mileage.

WN U-16
Zipty Fiber

Original Sheet 410

FACILITIES FOR INTRASTATE ACCESS

5. SPECIAL ACCESS (Cont'd)

5.7 Rates and Charges (Cont'd)

5.7.10 High Capacity Digital Fractional T1 (FT1) Facilities¹ (Cont'd)

	<u>Nonrecurring Charges</u>	<u>Monthly Rate</u>
(A) <u>Standard Arrangements</u> (Cont'd)		
(3) 6 x 56 Kbps or 6 x 64 Kbps Special Access Line	\$450.00	\$119.39
Special Transport, per airline mile ²	--	7.50
Special Transport Termination	--	24.00
(B) <u>FT1 Optional Payment Plan</u>		
(1) 2 x 56 Kbps or 2 x 64 Kbps Special Access Line		
One Year	--	100.00
Three Year	--	90.00
Five Year	--	80.00
Special Transport, per airline mile ²	--	5.50
Special Transport Termination	--	12.00

¹ Limited to those services so equipped and in service as of September 3, 1996.

² Rate also applicable for Intraexchange Interoffice mileage.

WN U-16
ZiPLY Fiber

Original Sheet 411

FACILITIES FOR INTRASTATE ACCESS

5. SPECIAL ACCESS (Cont'd)

5.7 Rates and Charges (Cont'd)

5.7.10 High Capacity Digital Fractional (FT1) Facilities¹ (Cont'd)

	<u>Nonrecurring Charges</u>	<u>Monthly Rate</u>
(B) <u>FT1 Optional Payment Plan</u> (Cont'd)		
(2) 4 x 56 Kbps or 4 x 64 Kbps Special Access Line		
One Year	--	\$110.00
Three Year	--	99.00
Five Year	--	88.00
Special Transport, per airline mile ²	--	6.50
Special Transport Termination	--	18.00

¹ Limited to those services so equipped and in service as of September 3, 1996.

² Rate also applicable for Intraexchange Interoffice mileage.

WN U-16
Zipty Fiber

Original Sheet 412

FACILITIES FOR INTRASTATE ACCESS

5. SPECIAL ACCESS (Cont'd)

5.7 Rates and Charges (Cont'd)

5.7.10 High Capacity Digital Fractional (FT1) Facilities¹ (Cont'd)

	<u>Nonrecurring Charges</u>	<u>Monthly Rate</u>
(B) <u>FT1 Optional Payment Plan</u> (Cont'd)		
(3) 6 x 56 Kbps or 6 x 64 Kbps Special Access Line		
One Year	--	\$119.00
Three Year	--	107.10
Five Year	--	95.20
Special Transport, per airline mile ²	--	7.50
Special Transport Termination	--	24.00

¹ Limited to those services so equipped and in service as of September 3, 1996.

² Rate also applicable for Intraexchange Interoffice mileage.

WN U-16
Zipty Fiber

Original Sheet 413

FACILITIES FOR INTRASTATE ACCESS

5. SPECIAL ACCESS (Cont'd)

5.7 Rates and Charges (Cont'd)

5.7.11 High Capacity DS3 (44.736 Mbps) Facilities - Three System

	<u>Nonrecurring Charges</u>	<u>Monthly Rate</u>
(A) <u>Electrical Interface</u>		
Special Access Line		
One Year	\$545.00	\$2,450.00
Three Year	545.00	2,275.00
Five Year	545.00	2,025.00
Seven Year	545.00	1,900.00

WN U-16
ZiPLY Fiber

Original Sheet 414

FACILITIES FOR INTRASTATE ACCESS

5. SPECIAL ACCESS (Cont'd)

5.7 Rates and Charges (Cont'd)

5.7.11 High Capacity DS3 (44.736 Mbps) Facilities - Three System (Cont'd)

	<u>Nonrecurring Charges</u>	<u>Monthly Rate</u>
(A) <u>Electrical Interface</u> (Cont'd)		
Each Additional Special Access Line - Maximum of 2		
One Year	\$545.00	\$150.00
Three Year	545.00	130.00
Five Year	545.00	115.00
Seven Year	545.00	110.00

WN U-16
Zipty Fiber

Original Sheet 415

FACILITIES FOR INTRASTATE ACCESS

5. SPECIAL ACCESS (Cont'd)

5.7 Rates and Charges (Cont'd)

5.7.12 High Capacity DS3 (44.736 Mbps) Facilities - Individual System

	<u>Nonrecurring Charges</u>	<u>Monthly Rate</u>
(A) <u>Electrical Interface</u>		
Each Special Access Line		
One Year	\$545.00	\$1,250.00
Three Year	545.00	990.00
Five Year	545.00	970.00
Seven Year	545.00	610.00

WN U-16
Zipty Fiber

Original Sheet 416

FACILITIES FOR INTRASTATE ACCESS

5. SPECIAL ACCESS (Cont'd)

5.7 Rates and Charges (Cont'd)

5.7.13 High Capacity DS3 (44.736 Mbps) Facilities - Special Transport

	<u>Monthly Rate</u>
(A) <u>DS3 Special Transport Termination</u>	
3 System or Individual Transport, per Termination	\$295.00
(B) <u>DS3 Special Transport Facilities</u>	
3 System or Individual Transport, per Airline Mile	51.00
	<u>Nonrecurring Charge</u>
5.7.14 <u>High Capacity DS3 (44.736 Mbps) Facilities - DS3 Multiplexer Cross Connect Arrangement</u>	
(A) DS3 Multiplexer Cross Connect Arrangement, per Arrangement	65.00

WN U-16
Zipty Fiber

Original Sheet 417

FACILITIES FOR INTRASTATE ACCESS

5. SPECIAL ACCESS (Cont'd)

5.7 Rates and Charges (Cont'd)

5.7.15 Digital Data Service Facilities

	<u>Nonrecurring Charges</u>	<u>Monthly Rate</u>
(A) <u>Standard Arrangements</u>		
Special Transport - All Speeds, per airline mile*	--	\$4.45
Special Access Line - All Speeds Month-to-month	--	91.54
(B) <u>Optional Arrangements</u>		
Supplemental Features, per Port		
DDS Bridging	--	4.70

* Rate also applicable for Intraexchange Interoffice mileage.

WN U-16
Zipty Fiber

Original Sheet 418

FACILITIES FOR INTRASTATE ACCESS

5. SPECIAL ACCESS (Cont'd)

5.7 Rates and Charges (Cont'd)

5.7.15 Digital Data Service Facilities (Cont'd)

(C) <u>DDS Optional Payment Plan</u>	<u>Nonrecurring Charges</u>	<u>Monthly Rate</u>
Special Access Line - 2.4, 4.8, 9.6 and 19.2 Kbps		
One Year	\$0.00	\$101.54
Three Year	0.00	91.54
Five Year	0.00	81.54

WN U-16
Zipty Fiber

Original Sheet 419

FACILITIES FOR INTRASTATE ACCESS

5. SPECIAL ACCESS (Cont'd)

5.7 Rates and Charges (Cont'd)

5.7.15 Digital Data Service Facilities (Cont'd)

(C) <u>DDS Optional Payment Plan</u> (Cont'd)	<u>Nonrecurring Charges</u>	<u>Monthly Rate</u>
Special Access Line - 56, 64 Kbps		
One Year	\$0.00	\$101.54
Three Year	0.00	91.54
Five Year	0.00	81.54

WN U-16
Zipty Fiber

Original Sheet 420

FACILITIES FOR INTRASTATE ACCESS

5. SPECIAL ACCESS (Cont'd)

5.7 Rates and Charges (Cont'd)

5.7.16 Multiplexing Arrangements

	<u>Nonrecurring Charges</u>	<u>Monthly Rate</u>
Voice to Narrowband ¹	\$5,665.81	\$247.24
DS1 to Voice	300.00	150.00
DS1C to Voice	8,349.12	517.57
DS1C to DS1	8,349.12	300.62
DS3 to DS1	355.00	347.00

5.7.17 High Voltage Protection

Initial Common Equipment	500.00	108.22
Terminating Equipment, per circuit		50.00
28.81		

¹ Obsolete offering limited to those circuits so equipped and in service as of September 26, 1991.

WN U-16
Zipty Fiber

Original Sheet 421

FACILITIES FOR INTRASTATE ACCESS

5. SPECIAL ACCESS (Cont'd)

5.7 Rates and Charges (Cont'd)

5.7.18 Digital Data Multiplexer

	<u>Nonrecurring Charges</u>	<u>Monthly Rate</u>
Digital Data Carrier Multiplexer		
Common Equipment	\$1,500.38	\$167.40
Each 64 kbps per Port	245.97	13.94
Digital Data Subrate Multiplexer		
One 64 kbps to Twenty 2.4 kbps	2,120.18	236.25
One 64 kbps to Ten 4.8 kbps	2,120.18	253.07
One 64 kbps to Five 9.6 kbps	2,120.18	229.29

WN U-16
ZiPLY Fiber

Original Sheet 422

FACILITIES FOR INTRASTATE ACCESS

5. SPECIAL ACCESS (Cont'd)

5.8 Miscellaneous Special Access Services

5.8.1 Clear Channel Capability

(A) Description of Service

An arrangement that allows the customer to transport 1.536 Mbps of information through a DS1 with no constraint on the quantity or sequence of one (Mark) and zero (space) bits utilizing the Bipolar with Eight Zero Substitution (B8ZS) Method of providing bit sequence independence. This arrangement is capable of transporting DS1 signals which utilize Superframe or Extended Superframe Format (ESF) as defined by the American National Standards Institute (ANSI) T1.107-1988 standard. The installation interval for Clear Channel Capability may exceed standard intervals where equipment in the central office is not readily available. The charges apply on a per SAL basis.

This arrangement requires the customer signal at the channel interface to conform to the B8ZS method of providing bit sequence independence, as described in ANSI T1.102-1987 and Section 6103 of the Technical Interface Reference Manual.

(B) Rates

The following charges apply on a per SAL basis.

<u>Nonrecurring Charge</u>	<u>Monthly Rate</u>
--	\$10.00

WN U-16
Zipty Fiber

Original Sheet 423

FACILITIES FOR INTRASTATE ACCESS

SECTION 6 TABLE OF CONTENTS

6. <u>MISCELLANEOUS SERVICES</u>	<u>Sheet No.</u>
6.1 <u>General</u>	426
6.2 <u>Additional Labor</u>	427
6.2.1 Overtime Installation	427
6.2.2 Overtime Repair.....	427
6.2.3 Additional Installation Testing	428
6.2.4 Standby	428
6.2.5 Testing and Maintenance with Other Telephone Companies.....	428
6.2.6 Charges for Additional Labor.....	429
6.3 <u>Maintenance of Service Charge</u>	430
6.4 <u>Telecommunications Service Priority (TSP) System</u>	431
6.4.1 Description of the Service	431
6.4.2 Obtaining TSP System Service	432
6.4.3 Provisioning Priority	433
6.4.4 Restoration Priority	433
6.4.5 Obligations of the Customer.....	434
6.4.6 Obligations of the Telephone Company.....	435
6.4.7 Rates and Charges	435

WN U-16
ZiPLY Fiber

Original Sheet 424

FACILITIES FOR INTRASTATE ACCESS

SECTION 6 TABLE OF CONTENTS

6. <u>MISCELLANEOUS SERVICE</u> (Cont'd)	<u>Sheet No.</u>
6.5 <u>Balloting and Allocation Process for Equal Access</u>	437
6.5.1 End User Notification and Equal Access Balloting Process	438
(A) InterLATA Equal Access	438
(B) IntraLATA Equal Access	440
6.5.2 Allocation Process	441
6.5.3 Interexchange Carrier Customer Lists	442
6.5.4 End User Choice Discrepancy.....	442
6.5.5 PIC and IPIC Charge Application	445
6.5.6 Unauthorized Primary InterLATA Carrier (PIC) or Primary IntraLATA Carrier (IPIC) Restoral Change.....	445
6.5.7 Multi-party End Users	445
6.5.8 Cancellation of a Carrier Participation	446
6.5.9 Liability of the Telephone Company	446
6.5.10 Carrier Desired Due Date (ICDDD) for PIC or IPIC Installation	446
6.5.11 Rates and Charges	447
6.5.12 Residential and Business Customers – IntraLATA Primary Exchange Carrier (“IPIC”) and Primary InterLATA Carrier (“PIC”) Change Charge Credit	447
6.6 <u>Additional Testing</u>	448
6.6.1 Switched Access Testing	448
6.6.2 Special Access Testing	452
6.6.3 Rates and Charges	453

WN U-16
Zipty Fiber

Original Sheet 425

FACILITIES FOR INTRASTATE ACCESS

SECTION 6 TABLE OF CONTENTS

6. MISCELLANEOUS SERVICE (Cont'd)	<u>Sheet No.</u>
6.7 <u>End User Lists</u>	454
6.7.1 Presubscription Lists.....	454
(A) InterLATA Equal Access	454
(B) IntraLATA Equal Access	456
6.7.2 Allocations Lists.....	459
6.7.3 Snapshot List.....	459
6.7.4 Rates and Charges	460
6.8 <u>Billing Name and Address Services (BNAS)</u>	461
6.8.1 BNA and Data Gathering Services	461
6.8.2 End User Validation List.....	465
6.8.3 Rates and Charges	466
(A) Billing Name and Address	466
(B) Data Gathering Service.....	466
(C) End User Validation List.....	466

WN U-16
Zipty Fiber

Original Sheet 426

FACILITIES FOR INTRASTATE ACCESS

6. MISCELLANEOUS SERVICES

6.1 General

Miscellaneous Services available to the customer include the following:

- (A) Additional Labor (i.e., Overtime Installation, Overtime Repair, Additional Installation Testing, Standby, Testing and Maintenance with Other Telephone Companies)
- (B) Maintenance of Service
- (C) Telecommunications Service Priority (TSP) System
- (D) Balloting and Allocation Process for Equal Access
- (E) Additional Testing
- (F) End User Lists
- (G) Billing Name and Address Services

These services are described in detail in 6.2 through 6.8.

WN U-16
Zipty Fiber

Original Sheet 427

FACILITIES FOR INTRASTATE ACCESS

6. MISCELLANEOUS SERVICES (Cont'd)

6.2 Additional Labor

Additional Labor is that labor requested by the customer on a given FIA and agreed to by the Telephone Company as described in 6.2.1 through 6.2.4. The Telephone Company will notify the customer that Additional Labor charges 6.2.6 will apply before any Additional Labor is undertaken. Additional Labor charges will also apply if the requirement for the Additional Labor is the fault of the customer or parties on whose behalf it acts.

6.2.1 Overtime Installation

Overtime installation is that Telephone Company installation effort outside the business day. Overtime rates will apply anytime outside the business day and all day Saturday. Premium time rates will apply all day Sunday and on all Telephone Company approved holidays. For applicable holidays contact the Telephone Company.

6.2.2 Overtime Repair

Overtime repair is Telephone Company repair which could have been performed during the normal business day, that is delayed at the specific request of the customer to a later time period which is outside the normal business day or to a weekend day or a holiday. The request will result in the application of overtime rates anytime outside the business day and all day Saturday. Premium time rates will apply on Sunday and Telephone Company approved holidays. These rates, as described in Section 6.2, will only apply when there is a delay of repair at the request of the customer to the time periods stated above.

WN U-16
Zipty Fiber

Original Sheet 428

FACILITIES FOR INTRASTATE ACCESS

6. MISCELLANEOUS SERVICES (Cont'd)

6.2 Additional Labor

6.2.3 Additional Installation Testing

Additional installation testing is that testing performed by the Telephone Company at the time of installation which is in addition to normal pre-service and acceptance testing.

6.2.4 Standby

Standby includes all time in excess of one-half (1/2) hour during which Telephone Company personnel are available to make coordinated tests on a given FIA. The standby charge applies only when Telephone Company personnel must wait more than 30 minutes beyond a prearranged, mutually agreed appointment time. Standby charges will cease when testing begins, or when Telephone Company personnel are released from the standby requirement, or when testing is rescheduled for a later date or time. Charges will not be applicable if Telephone Company personnel cause the delay.

6.2.5 Testing and Maintenance with Other Telephone Companies

Additional testing, maintenance, or repair of facilities which connect to facilities of other telephone companies, which is in addition to normal effort required to test, maintain, or repair facilities provided solely by the Telephone Company.

WN U-16
Zipty Fiber

Original Sheet 429

FACILITIES FOR INTRASTATE ACCESS

6. MISCELLANEOUS SERVICES (Cont'd)

6.2 Additional Labor

6.2.6 Charges for Additional Labor

Labor Periods	<u>First Half Hour or Fraction Thereof</u>	<u>Each Additional Half Hour or Fraction Thereof</u>
Basic Time, Business Day, Per Technician	\$29.79	\$19.86
Overtime, Outside the Business Day, Per Technician ¹	36.26	24.16
Premium Time, Outside the Business Day, Per Technician ¹	42.72	28.47

¹ A call out of a Telephone Company employee at a time not consecutive with the business day is subject to a minimum charge of four hours.

WN U-16
ZiPLY Fiber

Original Sheet 430

FACILITIES FOR INTRASTATE ACCESS

6. MISCELLANEOUS SERVICES (Cont'd)

6.3 Maintenance of Service Charge

6.3.1 When a customer reports trouble to the Telephone Company for clearance, the customer shall be responsible for payment of a Maintenance of Service Charge when Telephone Company personnel are dispatched to the customer's location and no trouble is found in the Telephone Company's facilities. Failure of Telephone Company personnel to find trouble in Telephone Company facilities will result in no charge if the trouble is actually in those facilities, but not discovered at the time.

In this case, or in (B), no credit allowance will be applicable for the interruption involved, unless the trouble is found in the Telephone Company's facilities.

6.3.2 The customer shall be responsible for payment of a Maintenance of Service Charge when the Telephone Company dispatches personnel to the customer's location and the trouble is in equipment or communications systems provided by other than the Telephone Company or in detariffed CPE provided by the Telephone Company.

6.3.3 The Maintenance of Service Charge time period will begin when Telephone Company personnel are dispatched. This will only include the actual time required to reach the customer's location and perform an investigation. The time period will end when the investigation is finished. The labor charge in 6.2(G) will apply to Maintenance of Service at the appropriate Basic, Overtime or Premium rate. These charges apply whether the trouble is in the equipment of communications systems provided by other than the Telephone Company, or in detariffed CPE provided by the Telephone Company.

WN U-16
Zipty Fiber

Original Sheet 431

FACILITIES FOR INTRASTATE ACCESS

6. MISCELLANEOUS SERVICES (Cont'd)

6.4 Telecommunications Service Priority (TSP) System

6.4.1 Description of the Service

The TSP System is a service that provides for the priority provisioning and/or restoration of National Security Emergency Preparedness (NSEP) telecommunications services. The TSP system applies only to NSEP services, includes both Switched and Special FIA and provides the Telephone Company with a guide to the sequence in which services are to be provisioned and/or restored.

All FIA that can be identified by a unique circuit identifier, can be provisioned for NSEP service by the Telephone Company.

The rates and charges associated with a customer subscribing to the TSP System are as specified in Section 6.4.7.

Issued: July 29, 2020
Issued by Zipty Fiber
By Jessica Epley, Regulatory & External Affairs Director

Effective: July 31, 2020

WN U-16
ZiPLY Fiber

Original Sheet 432

FACILITIES FOR INTRASTATE ACCESS

6. MISCELLANEOUS SERVICES (Cont'd)

6.4 Telecommunications Service Priority (TSP) System (Cont'd)

6.4.2 Obtaining TSP System Service

The Executive Office of the President, through the TSP Program Office, is empowered with the authority to receive, evaluate and process requests for NSEP services. The TSP Program Office makes the priority level assignments and issues the TSP authorization code reflecting the priority assignment associated with a request. The customer provides the TSP authorization code, in addition to all the other details necessary to complete the order (ASR), to the Telephone Company to obtain TSP System Service.

The TSP authorization coded assigned on a per ASR basis, consists of a 12-character field, a nine-character control ID followed by a dash and a two-character field specifying the priority level assignment. Its structure is as follows:

TSPxxxxxn-yy

The "x"s represent a sequence of numbers unique to each TSP authorization code and the "n" is a one character alphanumeric check digit. The first "y" contains the provisioning priority level assignment and the second "y" contains the restoration priority level assignment.

WN U-16
Zipty Fiber

Original Sheet 433

FACILITIES FOR INTRASTATE ACCESS

6. MISCELLANEOUS SERVICES (Cont'd)

6.4 Telecommunications Service Priority (TSP) System (Cont'd)

6.4.3 Provisioning Priority

If the customer requires service within a shorter time interval than the Telephone Company can provide, and the requested service qualifies for NSEP, the customer may elect to invoke NSEP treatment and obtain the appropriate provisioning priority assignment from the TSP Program Office. Acceptable assignment code values are: E, 1, 2, 3, 4, 5 or 0.

The assignment of the value "E" denotes Emergency Provisioning and implies the service has the most critical provisioning requirements and the Telephone Company will respond accordingly. The Telephone Company will take immediate action to provide the requested service at the earliest possible date. Rates and charges associated with "E" provisioning are specified in Section 6.4.7.

The assignment values of 1, 2, 3, 4 and 5 are treated as essential service priorities and the Company will adjust its available resources to meet the customer's requested due date. Rates and charges associated with invoking this priority treatment are specified in Section 6.4.7. The value "0" implies no provisioning priority.

6.4.4 Restoration Priority

TSP authorization code for restoration priority classifies the service as being among the nation's most important NSEP telecommunication services. The Company will restore these services before service without restoration priority assignments in the order of priority assignments. Acceptable values are: 1, 2, 3, 4, 5 or 0 with the value "1" being the highest priority.

When the Company recognizes a TSP as being out of service, unusable or receives a trouble report, available resources will be dispatched to restore the service as quickly as practicable. A priority value of 1, 2 or 3 requires dispatch outside normal business hours if necessary to restore the service. A priority value of 4 or 5 only requires dispatch outside of normal business hours if the next business day is more than 24 hours away. If the value "0" has been assigned, then no restoration priority is applicable to this service.

The minimum period for service is one month.

WN U-16
ZiPLY Fiber

Original Sheet 434

FACILITIES FOR INTRASTATE ACCESS

6. MISCELLANEOUS SERVICES (Cont'd)

6.4 Telecommunications Service Priority (TSP) System (Cont'd)

6.4.5 Obligations of the Customer

- (A) In all instances, the customer is responsible for obtaining the appropriate TSP authorization code and providing that code to the Telephone Company.
- (B) The TSP System service customer must also be the customer for the FIA with which TSP service is associated. Only the customer or its authorized agent as indicated in a letter of agency on file with the Telephone Company is allowed to order TSP System service.
- (C) All points of a multipoint service configuration must have the same restoration priority assignment and must satisfy the requirements of that assignment.
- (D) In obtaining TSP System service, the customer consents to the release of certain information by the Telephone Company to the federal government in order to maintain and administer the TSP System. Such information includes: the customer's name, telephone number and mailing address, the TSP authorization code and the circuit or service ID number associated with the NSEP service.
- (E) The Telephone Company will attempt to notify the customer of expected charges. The customer, when invoking NSEP treatment, recognizes that quoting charges and obtaining permission beforehand may not be practicable and may cause unnecessary delays and, as a result, grants the Telephone Company the right to quote and bill charges after provisioning of the service.
- (F) During certain emergencies, the customer may request TSP assignments verbally and the Telephone Company will accept such verbal notification. The customer must submit a written order (ASR) to the Telephone Company within two working days following the verbal request. If the written order (ASR) is not received within two working days, all applicable rates and charges accumulated to date to provision TSP System service become immediately due and payable and the requested TSP priority is revoked.
- (G) The customer must request and justify revalidation of all priority level assignments at least every three years.
- (H) Additionally, the NCS Manual 3-1-1, "Telecommunications Service Priority (TSP) System for National Security Emergency Preparedness (NSEP) Service User Manual", dated July 9, 1990, prescribes specific conditions which warrant NSEP Treatment and related procedures.

WN U-16
ZiPLY Fiber

Original Sheet 435

FACILITIES FOR INTRASTATE ACCESS

6. MISCELLANEOUS SERVICES (Cont'd)

6.4 Telecommunications Service Priority (TSP) System (Cont'd)

6.4.6 Obligations of the Telephone Company

- (A) The Telephone Company will allocate resources to ensure best efforts to provide NSEP services by the time required.
- (B) The Telephone Company will work TSP System services in the order of their priority level assignments. The priority sequence is as follows:
 - Restore NSEP services assigned restoration priority 1
 - Provision Emergency (E) NSEP services
 - Restore NSEP services assigned restoration priority 2, 3, 4 or 5
 - Provision NSEP services assigned provisioning priority 1, 2, 3, 4 or 5.
- (C) The Telephone Company will work cooperatively with other providers of NSEP service when only a portion is provided by the Telephone Company to ensure "end-to-end" service.
- (D) Additionally, TSP System service will be provided in accordance with the guidelines in "NCS Handbook 3-1-2, Telecommunications Service Priority (TSP) System for National Security Emergency Preparedness (NSEP) Service Vendor Handbook" dated July 9, 1990.

6.4.7 Rates and Charges

The following rates and charges are in addition to all other rates and charges that may apply for other services offered under this tariff which operate with the TSP System.

WN U-16
ZiPLY Fiber

Original Sheet 436

FACILITIES FOR INTRASTATE ACCESS

6. MISCELLANEOUS SERVICES (Cont'd)

6.4 Telecommunications Service Priority (TSP) System (Cont'd)

6.4.7 Rates and Charges (Cont'd)

(A) Establishment of TSP System Service

The establishment of TSP System Service is a nonrecurring charge (NRC) specified below which applies when a FIA is ordered with provisioning and/or restoration priority. If both are ordered at the same time, only one NRC is applicable. The NRC is also applicable for orders changing priority levels.

<u>Nonrecurring Charge,</u> <u>Per Circuit</u>	<u>Rate</u>
	\$14.50

(B) Provisioning Priority

There are two basic levels of provisioning priority, Emergency (provisioning priority "E") and Essential (provisioning priority 1, 2, 3, 4 or 5).

(1) Emergency Provisioning

The Telephone Company will take immediate action to provide the requested service at the earliest possible date. The rates and charges will apply as described in Section 10, Special Construction.

(2) Essential Provisioning

The Telephone Company will adjust its available resources to meet the customer's requested due date. The rates and charges will apply as found in Section 3.2.2(E).

WN U-16
ZiPLY Fiber

Original Sheet 437

FACILITIES FOR INTRASTATE ACCESS

6. MISCELLANEOUS SERVICES (Cont'd)

6.4 Telecommunications Service Priority (TSP) System (Cont'd)

6.4.7 Rates and Charges (Cont'd)

(C) Restoration Priority

Restoration Priority is a monthly rate per circuit for the ongoing administration and maintenance of the TSP System. This monthly rate only applies when a restoration priority code (1, 2, 3, 4 or 5) is specified in position 12 of the authorization code.

Monthly Rate Per Circuit, (PR9PX, PR9SX) (TSP PRI SERV, TSP SEC SERV)	<u>Rate</u>
	\$4.90

6.5 Balloting and Allocation Process for Equal Access

The Balloting and Allocation Process is an arrangement whereby:

- An end user may select or be allocated to an interexchange carrier (IC) to place intrastate, interLATA MTS/MTS-type calls without the 101XXXX access code. This IC is referred to as the end user's interLATA primary interexchange carrier (PIC).
- An end user may select or be allocated to an IC or local exchange carrier (LEC) to place intrastate, intraLATA MTS/MTS-type calls without the 101XXXX access code. This IC or LEC is referred to as the end user's intraLATA primary interexchange carrier (IPIC).

WN U-16
ZiPLY Fiber

Original Sheet 438

FACILITIES FOR INTRASTATE ACCESS

6. MISCELLANEOUS SERVICES (Cont'd)

6.5 Balloting and Allocation Process for Equal Access (Cont'd)

Balloting and Allocation applies to agents of public or semi-public pay telephone service whereby the agent may select or be allocated to an IC to place Intrastate intraLATA calls without dialing the 101XXXX access code.

In the event that only one IC orders FGD or BSA-D to provide interLATA service or no IC or LEC orders FGD or BSA-D to provide intraLATA service from an end office in accordance with 3.1.1(E), the Balloting and Allocation Process for the PIC or IPIC described below will not apply.

On the effective date(s) of interLATA and intraLATA equal access (i.e., introduction of FGD or BSA-D in a serving end office), end users or agents who have not designated or been allocated to an IC or LEC will continue with the same IC or LEC service arrangement as existed prior to office conversion until the allocation process described in 6.5.2 occurs.

6.5.1 End User Notification and Equal Access Balloting Process

(A) InterLATA Equal Access

End users will be notified of the availability of equal access by means of an equal access ballot. ICs intending to participate in the Balloting Process for each serving end office must inform the Telephone Company in writing no later than 120 days prior to the end office conversion to FGD or BSA-D. The initial ballot, the first of two ballots the end user may receive, listing all ICs participating in the balloting process, and an explanation of equal access will be mailed to the end user approximately 90 days prior to the end office conversion to FGD or BSA-D. IC names appearing on the ballot will be listed in a random fashion by end office to ensure that no IC will always appear first on the ballot.

WN U-16
Zipty Fiber

Original Sheet 439

FACILITIES FOR INTRASTATE ACCESS

6. MISCELLANEOUS SERVICES (Cont'd)

6.5 Balloting and Allocation Process for Equal Access (Cont'd)

6.5.1 End User Notification and Equal Access Balloting Process (Cont'd)

(A) InterLATA Equal Access (Cont'd)

Using the initial ballot, which end users will be requested to return within 45 days after receipt, the end user or agent may designate an IC for all of its lines or may choose a different PIC for each of its lines. Where an end user has a multi-line hunt group and wants to designate several PICs for this hunt group, special arrangements may be made by contacting the Telephone Company.

A second ballot will be sent to an end user who has not designated an IC, either by return of the initial ballot or by appearing on an IC Customer list. The second ballot will be sent 30 days after conversion of the end office. If the end user does not respond to the second ballot by the requested date, then that end user will be assigned to the allocated IC shown on the second ballot.

WN U-16
Zipty Fiber

Original Sheet 440

FACILITIES FOR INTRASTATE ACCESS

6. MISCELLANEOUS SERVICES (Cont'd)

6.5 Balloting and Allocation Process for Equal Access (Cont'd)

6.5.1 End User Notification and Equal Access Balloting Process (Cont'd)

(B) IntraLATA Equal Access

When intraLATA and interLATA equal access are made available concurrently, end users will be notified of the availability of equal access by means of an equal access ballot. ICs and LECs intending to participate in the Balloting Process for each serving end office must inform the Telephone Company in writing no later than 120 days prior to the end office conversion to FGD or BSA-D. The initial ballot, the first of two ballots the end user may receive, listing all ICs and LECs participating in the balloting process, and an explanation of equal access will be mailed to the end user approximately 90 days prior to the end office conversion to FGD or BSA-D. IC and LEC names appearing on the ballot will be listed in a random fashion by end office to ensure that no IC or LEC will always appear first on the ballot.

Using the initial ballot, which end users will be requested to return within 45 days after receipt, the end user may designate an IC or LEC for all of its lines or may choose a different IPIC for each of its lines. Where an end user has a multi-line hunt group and wants to designate several IPICs for this hunt group, special arrangements may be made by contacting the Telephone Company. Customers may designate that they do not want a primary IC by notifying the Telephone Company. This choice is considered a valid selection and the nonrecurring charge as described in 6.5.11 will apply to any subsequent change made after the conversion date.

A second ballot will be sent to an end user who has not designated an IC or LEC, either by return of the initial ballot or by appearing on an IC or LEC Customer list. The second ballot will be sent 30 days after conversion of the end office. If the end user does not respond to the second ballot by the requested date, then that end user will be assigned to the allocated IC or LEC shown on the second ballot.

When intraLATA equal access is made available in an end office at some time after the end office has converted to interLATA equal access, the Balloting and Allocation process for the intraLATA IPIC will not apply.

WN U-16
ZiPLY Fiber

Original Sheet 441

FACILITIES FOR INTRASTATE ACCESS

6. MISCELLANEOUS SERVICES (Cont'd)

6.5 Balloting and Allocation Process for Equal Access (Cont'd)

6.5.2 Allocation Process

An IC or LEC must notify the Telephone Company of its intent to participate in the allocation process 52 days prior to the end office conversion to equal access. The IC or LEC must also identify whether it will participate in the allocation of business lines or residence lines or any combination.

The Telephone Company will tabulate the initial ballots received from the end users described in 6.5.1 and the IC and LEC Customer lists described in 6.5.3. The percentage of end users who have selected a participating IC or LEC will be determined from these ballots and lists. These percentages will be used for the allocation of end users who did not respond to the initial ballot or appear on an IC or LEC list. The percentages used for allocation will be determined approximately five days after end office conversion. A second ballot, indicated in 6.5.1, will be sent to end users who have been allocated to an IC or LEC.

Separate allocation processes will be used for residence and business lines. The number of end users designating an IC or LEC by returning the initial ballot or appearing on an IC or LEC end user list will be totaled. This total will be utilized to compute the percentages used for allocation of residence and business customers.

If an IC or LEC participating in the ballot process notifies the Telephone Company that it does not wish to participate in the allocation process, the percentage of customers allocable to that nonparticipating IC or LEC will be allocated to the remaining ICs and LECs.

WN U-16
Zipty Fiber

Original Sheet 442

FACILITIES FOR INTRASTATE ACCESS

6. MISCELLANEOUS SERVICES (Cont'd)

6.5 Balloting and Allocation Process for Equal Access (Cont'd)

6.5.3 Interexchange Carrier Customer Lists

The Telephone Company will accept IC and LEC Customer lists identifying end users who have made individual arrangements with the IC or LEC to designate the IC or LEC as their primary long distance carrier. The list should be in the form of magnetic tape or paper printout. IC and LEC lists may continue to be received after the initial ballot deadline. All lists must be submitted to the Telephone Company no later than 20 days prior to the end office conversion to be included in the allocation process. If end user ballots are received by the IC or LEC, the end user will be included in the IC or LEC Customer list. The IC or LEC must retain the actual ballots for inspection by the Telephone Company for a period of one year after end office conversion.

6.5.4 End User Choice Discrepancy

An IC or LEC is required to certify at the time it submits end user lists to the Telephone Company that it has on file, or has instituted steps designed to obtain signed letters of agency or confirmations of choice from the end user. The IC or LEC is not required to submit letters of agency when submitting end user lists to the Telephone Company, but should maintain the confirmations or letters on file for use in dispute resolution. The IC or LEC should request written confirmation of choice from its customers no later than the date of submission of its first bill to the customer.

WN U-16
Zipty Fiber

Original Sheet 443

FACILITIES FOR INTRASTATE ACCESS

6. MISCELLANEOUS SERVICES (Cont'd)

6.5 Balloting and Allocation Process for Equal Access (Cont'd)

6.5.4 End User Choice Discrepancy (Cont'd)

When an end user indicates more than one PIC or IPIC per line or returns an illegible ballot, the Telephone Company will contact the end user for clarification.

When the Telephone Company identifies a conflict between a ballot and an IC or LEC list, or between lists submitted by two or more ICs and/or LECs, the Telephone Company will notify, within 10 days, all affected ICs and LECs via a conflict report. Those ICs and LECs not involved in any conflicts will receive a zero conflict report from the Telephone Company.

When an end user returns a ballot to the Telephone Company and also appears on a conflicting IC or LEC Customer list, the ballot takes precedence. If an end user appears on two or more IC or LEC Customer lists, the end user will be allocated along with the nonrespondents to the initial ballot. A letter sent with the second ballot will inform the end user that there exists a conflict between two or more ICs and/or LECs and a selection must be made by the deadline of the second ballot, unless the allocated IC or LEC indicated is the end user's choice.

FACILITIES FOR INTRASTATE ACCESS

6. MISCELLANEOUS SERVICES (Cont'd)6.5 Balloting and Allocation Process for Equal Access (Cont'd)6.5.5 PIC and IPIC Charge Application

Initial end user, end user agent and a local service provider that resells services (herein referred to as reseller) selection of a PIC by ballot or appearing on an IC or, for intraLATA service a LEC list, will not incur a charge. A change of PIC selection prior to the end office conversion to interLATA equal access will not incur a charge. A change of IPIC selection prior to the end office conversion to intraLATA equal access will not incur a charge. Notification of a change in a PIC or IPIC may be coordinated by the end user, end user agent or reseller with either the IC or LEC selected or with the Telephone Company, if it is not the selected LEC. Within six months after conversion to equal access, an end user, end user agent or reseller allocated to an IC or LEC may elect to change to another IC or LEC at no charge, on a one-time basis. After the six month period has elapsed, a nonrecurring charge in 6.5.11 will apply to change the PIC or IPIC. After conversion to equal access, end users, end user agents or resellers who select an IC or LEC by returning the initial ballot will be charged for each change made. No PIC or IPIC charge is applicable to a new end user's initial selection of an IC or LEC for the Primary Interexchange arrangement.

In end offices converted to Equal Access new end users, end user agents and resellers of multi-party end users who upgrade to individual lines must presubscribe to the PIC and IPIC of their choice at the time an order is placed for service. Upon the end user's, end user agent's or reseller's selection of the PIC and IPIC, at the time of placing an order, a confirmation notice will be sent identifying the IC and/or LEC selected. From the date of the confirmation notice, they will have 90 days to change their presubscription selection without a charge, on a one-time basis. If a PIC or IPIC is not chosen at the time the order for service is submitted, the end user, end user agent or reseller will be sent a confirmation notice which will contain a list of ICs and LECs with FGD or BSA-D and will be informed that they have 90 days to contact the IC or LEC of their choice or the Telephone Company for the PIC arrangement. If notice is received by the Telephone Company within 90 days of the in-service date for local service or upgrade, no charge will be billed to the end user, end user agent or reseller. If notice is received after 90 days, the end user, end user agent or reseller will be billed a nonrecurring charge in 6.5.11. Until the end user, end user agent or reseller receives service from the selected IC or LEC, it may access the IC or LEC of choice by dialing the appropriate 10XXX OR 101XXXX carrier identification code.

The Telephone Company will make post conversion changes in the end user's, end user agent's or reseller's PIC or IPIC assignment pursuant to an IC or LEC provided list of customers, accepted by the Telephone Company under conditions in 6.5.3 and 6.5.4. Should an end user, end user agent or reseller dispute authorization of the change within two years of the PIC or IPIC assignment, the Telephone Company will place the end user on the previous carrier network where possible and the carrier will be billed according to 6.5.7.

WN U-16
Zipty Fiber

Original Sheet 445

FACILITIES FOR INTRASTATE ACCESS

6. MISCELLANEOUS SERVICES (Cont'd)

6.5 Balloting and Allocation Process for Equal Access (Cont'd)

6.5.6 Unauthorized Primary InterLATA Carrier (PIC) or Primary IntraLATA Carrier (IPIC) Restoral Change

An Unauthorized PIC or IPIC Change is a change in the preferred PIC or IPIC IC that the end user or Pay Telephone Service Provider denies authorizing.

If an end user or Pay Telephone Service Provider denies requesting a change in PIC or IPIC IC as submitted by the alleged unauthorized IC, the alleged unauthorized IC will be assessed the PIC or IPIC Charge as specified in 6.5.11 for:

- Changing the end user or Pay Telephone Service Provider to the disputed IC, and
- Placing the end user or Pay Telephone Service Provider on their previous IC network or the IC network of their choice.

In accordance with the Federal Communications Commission's Slamming Liability Rules in FCC Docket 94-129, if an alleged unauthorized carrier is ultimately exonerated of liability, the alleged unauthorized IC is entitled to receive full payment from the end user or Pay Telephone Service Provider for all services provided. In such situations, any PIC or IPIC Charges assessed against the alleged unauthorized IC by the Telephone Company are subject to rebilling to the end user or Pay Telephone Service Provider by the alleged unauthorized IC.

6.5.7 Multi-party End Users

Multi-party end users will continue with the same carrier service arrangement which existed prior to the end office conversion. However, multi-party end users may access the carrier of their choice by dialing the appropriate 101XXXX carrier identification code. In certain suitably equipped end offices, two-party customers may subscribe to the carrier of their choice.

FACILITIES FOR INTRASTATE ACCESS

6. MISCELLANEOUS SERVICES (Cont'd)6.5 Balloting and Allocation Process for Equal Access (Cont'd)6.5.8 Cancellation of a Carrier Participation

If an IC or LEC cancels all of its FGD or BSA-D service in the converting end office prior to the conversion date or discontinues all of its FGD or BSA-D service within two years after the introduction of FGD or BSA-D in the converting end office, the carrier is obligated to do the following:

- (A) Notify the Telephone Company of the cancellation of their FGD or BSA-D service, and
- (B) Contact in writing all end users, end user agents or resellers who have selected, or been allocated to, the canceling carrier as their PIC or IPIC, inform these end users, end user agents and resellers of the cancellation, request the end users, end user agents and resellers to select a new PIC or IPIC, and state that the canceling carrier will pay the nonrecurring charge in 6.5.11.

The Telephone Company will bill the canceling IC or LEC the nonrecurring charge in 6.5.11 for each end user, end user agent and reseller this carrier has currently designated to it, when the carrier discontinues FGD or BSA-D service within two years of the conversion of the end office to equal access. Such charge will not apply to the canceling carrier where the canceling IC or LEC transfers or assigns its FGD or BSA-D services and the associated 101XXXX code to another carrier in such manner that the Telephone Company does not change end user, end user agent or reseller records or if another carrier elects to pay nonrecurring charge on behalf of the canceling IC or LEC.

6.5.9 Liability of the Telephone Company

If through the fault of the Telephone Company, the end user, end user agent or reseller is not subscribed to its chosen PIC or IPIC, the nonrecurring charges in 6.5.11 do not apply to reassign the end user, end user agent or reseller to his chosen PIC or IPIC.

6.5.10 Carrier Desired Due Date (ICDDD) for PIC or IPIC Installation

An IC or LEC may request a desired due date for PIC or IPIC installation for a specific, single end user, end user agent or reseller acting on behalf of an end user post equal access conversion. This ICDDD is a mutually agreed upon negotiated due date, determined to be between 3 and 45 business days from the date of receipt of the order. The carrier must coordinate the ICDDD with the Telephone Company prior to sending in the first order.

The ICDDD does not apply to routine lists provided by the carrier, as described in 6.5.4. The Nonrecurring Charge for PIC or IPIC as found in 6.5.11, applies to each line converted to the carrier requesting ICDDD. This charge will be billed to the carrier's end user customer.

WN U-16
ZiPLY Fiber

Original Sheet 447

FACILITIES FOR INTRASTATE ACCESS

6. MISCELLANEOUS SERVICES (Cont'd)

6.5 Balloting and Allocation Process for Equal Access (Cont'd)

6.5.11 Rates and Charges

Nonrecurring Charge for Primary
InterLATA Carrier (PIC) or Primary
IntraLATA Carrier (IPIC)

The nonrecurring charge for PIC or
IPIC is as follows:

	<u>Nonrecurring Charge</u>
Per Telephone Company Local Service Line or Trunk ^{1,2}	\$ 4.35

6.5.12 Residential and Business Customers – IntraLATA Primary Exchange Carrier (“IPIC”) and Primary InterLATA Carrier (“PIC”) Change Charge Credit

Residence and business customers who change their local toll and/or long distance provider during the period commencing on the tariff effective date and continuing through October 18, 2010 from the Telephone Company to any other provider will receive a waiver of the \$4.35 nonrecurring IntraLATA Primary Exchange Carrier (IPIC) and/or Primary InterLATA Carrier (PIC) Change Charge.

¹ Rates commence on September 10, 1996.

² If a customer picks a single carrier for both intraLATA and interLATA toll calls during one transaction, only one \$4.35 charge will apply.

WN U-16
ZiPLY Fiber

Original Sheet 448

FACILITIES FOR INTRASTATE ACCESS

6. MISCELLANEOUS SERVICES (Cont'd)

6.6 Additional Testing

The Telephone Company will perform acceptance testing as specified in 4.2.7 and 5.1.5 to insure that FIA ordered by the customer are functioning properly, prior to turning over such FIA to the customer. In addition, the Telephone Company will perform ongoing tests as specified in 4.2.1 and 4.2.2 to assure the continued satisfactory performance of Switched Access Services ordered by the customer.

Testing offered under this section of the tariff is in addition to those tests described above and will be provided, when requested by the customer, at an additional charge.

Testing is provided by Telephone Company personnel at Telephone Company locations. However, provisions are made in 6.6.1(E) and 6.6.2(B), to allow a customer to request Telephone Company personnel to perform testing at the CDL or the end user premises.

Additional testing is provided on a scheduled or nonscheduled basis. Scheduled testing shall be performed on a predetermined time basis to allow for cost efficient utilization of Telephone Company and customer resources. Scheduled testing should be based on a one year period. Nonscheduled tests are performed by the Telephone Company on a request-by-request basis, not with any fixed schedule.

The offering of testing under this section of the tariff is made subject to the availability of the necessary qualified personnel and test equipment at the various test locations mentioned in (A), (B), and (C).

6.6.1 Switched Access Testing

Testing for Switched Access is comprised of (a) tests which are performed during the installation of Switched Access (i.e., acceptance tests) and (b) tests which are performed after acceptance of such Switched Access by a customer (i.e., in-service tests).

WN U-16
Zipty Fiber

Original Sheet 449

FACILITIES FOR INTRASTATE ACCESS

6. MISCELLANEOUS SERVICES (Cont'd)

6.6 Additional Testing (Cont'd)

6.6.1 Switched Access Testing (Cont'd)

These tests are performed on a scheduled or nonscheduled basis, and may be conducted on an automatic, cooperative, or manual basis, as defined in (A), (B), (C), (D), and (E).

(A) Additional Cooperative Acceptance Testing

Additional Cooperative Acceptance Testing (ACAT) of Switched Access involves the Telephone Company provision of a technician at its office(s) and the customer provision of a technician at its CDL, with suitable test equipment to perform the required tests.

ACAT may apply when the customer requests additional tests not specified in 4.2.7.

The labor charges in 6.2.6 will apply to ACAT at the appropriate Basic, Overtime, or Premium rate.

(B) Automatic Scheduled Testing

Automatic Scheduled Testing (AST) of FGB, FGC, FGD, BSA-B, BSA-C, BSA-D and SAC Access is provided, as specified in 4.2.1 and 4.2.2, where the customer provides remote office test lines and 105 test lines with associated responders or their functional equivalent. AST charges will apply when such testing is requested on a more frequent basis than is provided for in accordance with the Telephone Company's Central Office Maintenance Planning System (COMPS). The customer may specify a more frequent schedule of tests at least sixty days prior to the start of the prescribed schedule. Trunks from a Telephone Company digital switch, to a customer digital switch, utilizing digital facilities, are excluded from mandatory routine testing. The rates in 6.6.3(A) will apply to additional AST.

The Telephone Company will provide a monthly AST report that lists the trunks within each Central

Office access group that failed to meet established requirements. Trunk test failures requiring customer participation for trouble resolution will be provided to the customer on an as occurs basis. A monthly report that lists the test results will be provided to the customer.

WN U-16
Zipty Fiber

Original Sheet 450

FACILITIES FOR INTRASTATE ACCESS

6. MISCELLANEOUS SERVICES (Cont'd)

6.6 Additional Testing (Cont'd)

6.6.1 Switched Access Testing (Cont'd)

(C) Additional Cooperative Scheduled Testing

Additional Cooperative Scheduled Testing (ACST) of FGA, FGB, FGC, FGD, BSA-A, BSA-B, BSA-C, BSA-D and SAC Access Service occurs when the Telephone Company provides a technician at its office(s) and the customer provides a technician at its CDL, with suitable test equipment to perform the required tests. ACST charges will apply when loss/noise/balance testing or gain-slope testing is requested on a more frequent basis than is provided for in accordance with the Telephone Company's Central Office Maintenance Planning System (COMPS). ACST charges also apply when additional tests are requested for FGA, FGB, FGC, FGD, BSA-A, BSA-B, BSA-C, BSA-D or SAC Access Service that are not specified in 4.2.1 and 4.2.2. The customer may specify a more frequent schedule of tests sixty days prior to the start of the prescribed schedule. The rates in 6.6.3(B), will apply for additional ACST.

The Telephone Company will provide, on a quarterly basis, an ACST report that lists the test results and the number of trunks that passed or failed. Trunk test failures requiring customer participation for trouble resolution will be provided to the customer on an as occurs basis.

(D) Additional Manual Scheduled Testing

Additional Manual Scheduled Testing (AMST) of FGA, FGB, FGC, FGD, BSA-A, BSA-B, BSA-C, BSA-D or SAC Access Service occurs when the Telephone Company provides a technician at its office(s) and at the CDL. AMST charges will apply when loss/noise/balance testing or gain-slope testing is requested on a more frequent basis than is provided for in accordance with the Telephone Company's Central Office Maintenance Planning System (COMPS). AMST charges also apply when additional tests are requested for FGA, FGB, FGC, FGD, BSA-A, BSA-B, BSA-C, BSA-D or SAC Access Service that are not specified in 4.2.1 and 4.2.2. The customer may specify a more frequent schedule of tests sixty days prior to the start of the prescribed schedule. The rates in 6.6.3(B) will apply to additional AMST.

The Telephone Company will provide, on a quarterly basis, an AMST report that lists the test results and the number of trunks that passed or failed. Trunk test failures requiring customer participation for trouble resolution will be provided to the customer on an as occurs basis.

WN U-16
Zipty Fiber

Original Sheet 451

FACILITIES FOR INTRASTATE ACCESS

6. MISCELLANEOUS SERVICES (Cont'd)

6.6 Additional Testing (Cont'd)

6.6.1 Switched Access Testing (Cont'd)

(E) Nonscheduled Testing

Nonscheduled Testing (NST) will be performed "on demand" which results in the measurement of Switched Access. NST charges will apply only when testing is requested more frequently than is provided for in accordance with COMPS, or when a specific test is requested that is not normally performed. Tests for Switched Access which are normally performed are contained in 4.2.1 and 4.2.2. NST of Switched Access may consist of the following testing arrangements:

- the customer provides remote office test lines and 105 test lines with associated responders or their functional equivalent (automatic testing), or
- the Telephone Company provides a technician at its office(s) and the customer provides a technician at its CDL with suitable test equipment to perform the required tests (cooperative testing), or
- the Telephone Company provides a technician at its office(s), and at the CDL or end user premises with suitable test equipment to perform the required tests (manual testing).

Nonscheduled Tests may consist of any tests which the customer may require. The rates in 6.6(C)(1) will apply to Nonscheduled Automatic Testing. The labor charges in 6.6.3(A) will apply to Nonscheduled Cooperative and Manual FIA Testing at the appropriate Basic, Overtime, or Premium rate.

If nonscheduled tests are required and trouble is found in Telephone Company facilities, charges for testing the Telephone Company facilities will not apply. If, however, trouble is found in the customer equipment, charges as specified in 6.6.3(A) and labor charges in 6.2.6 are applicable.

(F) Obligations of the Customer

- (a) The customer shall provide the Remote Office Test Line priming data to the Telephone Company, as appropriate, to support AST as specified in 6.6.1(B) or NST as specified in 6.6.1(E).
- (b) The customer shall make the facilities to be tested available to the Telephone Company at times mutually agreed upon.

FACILITIES FOR INTRASTATE ACCESS

6. MISCELLANEOUS SERVICES (Cont'd)6.6 Additional Testing (Cont'd)6.6.2 Special Access Testing

The Telephone Company will, at the request of a customer, provide assistance in performing specific tests requested by the customer.

(A) Additional Cooperative Acceptance Testing

When a customer provides a technician at its CDL or at the end user premises, with suitable test equipment to perform the required tests, the Telephone Company will provide a technician at its office for the purpose of conducting Additional Cooperative Acceptance Testing (ACAT). The labor charges in 6.2(G) will apply to ACAT at the appropriate Basic, Overtime, or Premium rate.

ACAT charges will apply when the customer requests tests which are not required to meet the transmission performance parameters as described in the Technical Interface Reference Manual.

(B) Nonscheduled Testing

When a customer provides a technician at its CDL or at the end user premises, with suitable test equipment to perform the required tests, the Telephone Company will provide a technician at its office (cooperative testing) for the purpose of conducting Nonscheduled Testing (NST). NST may consist of any test (e.g., loss, noise, slope, envelope delay, etc.) which the customer may request. If such testing indicates trouble in Telephone Company facilities, then the customer will not be charged. NST charges will apply if the trouble is in the facilities of the customer. At the customer's request, the Telephone Company will provide a technician at the CDL or at the end user premises (manual testing). The labor charges in 6.2.6 will apply to NST at the appropriate Basic, Overtime, or Premium rate.

(C) Obligation of the Customer

When the customer subscribes to Testing as described in this section, the customer shall make the facilities to be tested available to the Telephone Company at times mutually agreed upon.

WN U-16
ZiPLY Fiber

Original Sheet 453

FACILITIES FOR INTRASTATE ACCESS

6. MISCELLANEOUS SERVICES (Cont'd)

6.6 Additional Testing (Cont'd)

6.6.3 Rates and Charges

Rate

(A) Additional Automatic Scheduled Testing

Basic Offering to First Point of Switching
per Transmission Path, per Month

\$.45

(B) Additional Cooperative Scheduled Testing

Basic Offering to First Point of Switching
per Transmission Path, per Month

1.69

Gain-Slope-To First Point of Switching
per Transmission Path, per Month

.72

(C) Additional Manual Scheduled Testing

Basic Offering to First Point of Switching
per Transmission Path, per Month

3.37

Gain-Slope-To First Point of Switching
per Transmission Path, per Month

1.43

WN U-16
Zipty Fiber

Original Sheet 454

FACILITIES FOR INTRASTATE ACCESS

6. MISCELLANEOUS SERVICES (Cont'd)

6.7 End User Lists

6.7.1 Presubscription List

(A) InterLATA Equal Access

Prior to conversion to equal access (i.e., introduction of FGD or BSA-D in an end office switch) an IC may request a list of the Telephone Company's end users of record served from that end office switch. The Presubscription List will be provided as follows:

- (1) The Telephone Company will provide a list from its Customer data base. The list may be provided on magnetic tape, electronic transmission or paper printout, at the option of the IC, at rates provided in 6.7.4. Foreign listings, PBX stations, CU centrex stations and numbers not in service will not be provided.
 - (a) The Initial List will be provided to the IC no later than 30 days after receipt of the order and payment by the IC of charges in 6.7.4. The nonrecurring charge for the Initial List applies per order. A single order may contain all end offices having the same equal access conversion date. The telephone number will not be provided if an end user or agent has a nonpublished number.

WN U-16
Zipty Fiber

Original Sheet 455

FACILITIES FOR INTRASTATE ACCESS

6. MISCELLANEOUS SERVICES (Cont'd)

6.7 End User Lists (Cont'd)

6.7.1 Presubscription List (Cont'd)

(A) InterLATA Equal Access (Cont'd)

(1) (Cont'd)

(a) The Account Activity List, which includes a listing of all changes to the Customer data base, since the Initial List was produced, will be provided on a cyclic basis. The Account Activity List will only include information for those end users that are presubscribed to the IC (including end users with nonpublished numbers) for the sole purpose of updating the IC's customer account information. There is no charge for this list.

(2) The IC agrees to use the Initial and Account Activity Lists for the sole purpose of contacting potential customers or existing customers, regarding interexchange telecommunications services available through equal access to be obtained from the Telephone Company or for the purpose of updating IC customer account information. The IC agrees not to sell, or reproduce in any manner, in whole or in part, the lists or permit such to be done.

(3) The IC shall indemnify, protect and save harmless the Telephone Company from and against any and all loss, liability, damages and expense arising out of any demand, claim, suit or judgment for damages which may arise out of the Telephone Company's supplying of listing information, services or records.

(4) The Telephone Company and the IC agree that the mutual objective of the parties is to conduct their respective businesses to avoid confusion by the end users as to the separate and independent identity of the respective companies and their services. Neither the Telephone Company nor the IC shall make any representation to end users, the public, prospective advertisers, expressed or implied, written or oral, which would imply that the IC is the same as, a part of, or associated with the Telephone Company.

(5) This service may be terminated by either the Telephone Company or the IC upon thirty (30) days' written notice. The Telephone Company reserves the right to terminate this service immediately upon written notice if the IC misuses the list information. Performance by the Telephone Company shall be excused in the event of strike, riot, act of God or any other cause beyond the reasonable control of the Telephone Company.

WN U-16
Zipty Fiber

Original Sheet 456

FACILITIES FOR INTRASTATE ACCESS

6. MISCELLANEOUS SERVICES (Cont'd)

6.7 End User Lists (Cont'd)

6.7.1 Presubscription List (Cont'd)

(B) IntraLATA Equal Access

Prior to conversion to intraLATA equal access an IC or LEC may request a list of the Telephone Company's end users of record served from that end office switch. A single Presubscription List will be provided to intraLATA toll providers as follows:

- (1) The Telephone Company will provide a list from its Customer data base. The list may be provided on magnetic tape, electronic transmission or paper printout, at the option of the IC or LEC, at rates provided in 6.8.3. Foreign listings, PBX stations, CU centrex stations, public coin station and numbers not in service will not be provided.
 - (a) The Initial List will be provided to the IC or LEC no later than 30 days after receipt of the order and payment by the IC or LEC of charges in 6.7.4(A). The nonrecurring charge for the Initial List applies per order. A single order may contain all end offices having the same intraLATA equal access conversion date. The telephone number will not be provided if an end user or agent has a nonpublished number.

WN U-16
Zipty Fiber

Original Sheet 457

FACILITIES FOR INTRASTATE ACCESS

6. MISCELLANEOUS SERVICES (Cont'd)

6.7 End User Lists (Cont'd)

6.7.1 Presubscription List (Cont'd)

(B) IntraLATA Equal Access (Cont'd)

(1) (Cont'd)

(b) The Account Activity List, which includes a listing of all changes to the customer database, since the Initial List was produced, will be provided on a cyclic basis based on the Telephone Company's billing cycles. The Account Activity List will only include information for those end users that are presubscribed to the IC or LEC (including end users with nonpublished numbers) for the sole purpose of updating the IC's or LEC's customer account information. There is no charge for this list.

(2) The IC or LEC agrees to use the Initial List for the sole purpose of contacting potential customers, or existing customers, regarding intraLATA telecommunications services available through equal access to be obtained from the Telephone Company. The IC or LEC agrees not to sell, or reproduce in any manner, in whole or in part, the lists or permit such to be done.

WN U-16
Zipty Fiber

Original Sheet 458

FACILITIES FOR INTRASTATE ACCESS

6. MISCELLANEOUS SERVICES (Cont'd)

6.7 End User Lists (Cont'd)

6.7.1 Presubscription List (Cont'd)

(B) IntraLATA Equal Access (Cont'd)

- (3) The IC or LEC shall indemnify, protect and save harmless the Telephone Company from and against any and all loss, liability, damages and expense arising out of any demand, claim, suit or judgment for damages which may arise out of the Telephone Company's supplying of listing information, services or records.
- (4) The Telephone Company and the IC or LEC agree that the mutual objective of the parties is to conduct their respective businesses to avoid confusion by the end users as to the separate and independent identity of the respective companies and their services. Neither the Telephone Company nor the IC or LEC shall make any representation to end users, the public, prospective advertisers, expressed or implied, written or oral, which would imply that the IC or LEC is the same as, a part of, or associated with the Telephone Company.
- (5) This service may be terminated by either the Telephone Company or the IC or LEC upon thirty (30) days' written notice. The Telephone Company reserves the right to terminate this service immediately upon written notice if the IC or LEC misuses the list information. Performance by the Telephone Company shall be excused in the event of strike, riot, act of God or any other cause beyond the reasonable control of the Telephone Company.

WN U-16
Zipty Fiber

Original Sheet 459

FACILITIES FOR INTRASTATE ACCESS

6. MISCELLANEOUS SERVICES (Cont'd)

6.7 End User Lists (Cont'd)

6.7.2 Allocation Lists

- (A) The Telephone Company will provide to the IC or LEC, at no charge, a list of end users that have been allocated to the IC or LEC as described in 6.5.2. This list will be provided after the Balloting and Allocation Process occurs.
- (B) A list of all end users who have been allocated, in accordance with 6.5.2, will be available to an IC or LEC upon request. Charges in 6.8.3 will apply. The nonrecurring charge for the Allocation List applies each time the IC or LEC orders the service. A single ASR may contain all end offices having the same equal access conversion date.

6.7.3 Snapshot List

The Snapshot List is a summary of selected end user information for a specific IC or LEC which resides in the Telephone Company Customer data base. The Snapshot List may be provided on magnetic tape, electronic transmission or paper printout, at the option of the IC or LEC, at rates provided in 6.7.4(B). Foreign listings, PBX stations, CU centrex stations and numbers not in service will not be provided.

The Snapshot List will be provided to the IC or LEC no later than 30 days after receipt of the order. The nonrecurring charge for the Snapshot List applies per order.

The purpose, liability and objectives associated with the provision of the Snapshot List is in 6.7.1(B)(2), (3), (4) and (5).

WN U-16
ZiPLY Fiber

Original Sheet 460

FACILITIES FOR INTRASTATE ACCESS

6. MISCELLANEOUS SERVICES (Cont'd)

6.7 End User Lists (Cont'd)

6.7.4 Rates and Charges

	<u>Charge</u>
(A) <u>Initial and Allocation Lists</u>	
Nonrecurring charge, per order	\$50.00
Initial List, per customer account	.03
Allocation List, per listing ¹	.03
(B) <u>Snapshot List</u>	
Nonrecurring Charge, per order	75.00
Snapshot List, per listing	.05

¹ For purposes of the Allocation List, a listing is defined as an end user or agent record eligible for a Primary Interexchange Carrier selection.

WN U-16
Zipty Fiber

Original Sheet 461

FACILITIES FOR INTRASTATE ACCESS

6. MISCELLANEOUS SERVICES (Cont'd)

6.8 Billing Name and Address Services (BNAS)

The Telephone Company will, upon request, provide Billing Name and Address Services (BNAS) to a Telecommunications Service Provider (customer), or its authorized billing and collection agent. Telecommunications Service Providers include interexchange carriers, operator service providers, enhanced service providers, and any other provider of intrastate telecommunications services.

There are three BNAS offerings available pursuant to this tariff, Billing Name and Address (BNA), Data Gathering Service (DGS), and End User Validation List.

6.8.1 BNA and Data Gathering Services

BNA is the billing name and address information and Data Gathering is the billing telephone number, name, address and associated working telephone number information for customer- provided ten digit end user telephone numbers. TSPs may require the information to bill for end user calls placed within a specific time period. BNA and DGS are offered subject to the conditions specified in the following:

- (A) A standard format for the receipt and provision of telephone number and billing name and address information will be established by the Telephone Company. Charges for each BNA searched for and found or searched for and not found will be billed at rates in 6.8.3(A). Charges for each record accessed for DGS are in 6.8.3(B). BNA and DGS will be provided via magnetic tape, electronic transmission, or paper format, at the option of the customer, at rates in 6.8.3(A) and 6.8.3(B). The processing fee will be applied on a per state basis, once per calendar year for BNAS processing done within that calendar year.

WN U-16
Zipty Fiber

Original Sheet 462

FACILITIES FOR INTRASTATE ACCESS

6. MISCELLANEOUS SERVICES (Cont'd)

6.8 Billing Name and Address Services (BNAS) (Cont'd)

6.8.1 BNA and Data Gathering Services (Cont'd)

- (B) The customer must order BNA or DGS and provide a test data tape at least 30 days prior to delivery of the first customer order.
- (C) The frequency for receipt of the customer provided orders for BNA or DGS will be no more than twice monthly and at intervals mutually agreed upon between the Telephone Company and the customer. The customer provided end user telephone numbers will be programmed by the Telephone Company with the proper end user's billing name and address contained in the Telephone Company's file at that time.
- (D) BNA and DGS information for nonlisted/nonpublished end user telephone numbers will be provided unless the nonlisted/nonpublished end user provides notice of nonconsent to the Telephone Company for the release of the BNA/DGS data. Within 30 days of receipt of such notice, the Telephone Company will discontinue disclosure of the nonlisted/nonpublished BNA/DGS data.

WN U-16
Zipty Fiber

Original Sheet 463

FACILITIES FOR INTRASTATE ACCESS

6. MISCELLANEOUS SERVICES (Cont'd)

6.8 Billing Name and Address Services (BNAS) (Cont'd)

6.8.1 BNA and Data Gathering Services (Cont'd)

- (E) For other than electronic transmission, the output records will be sent to the customer via first class U. S. Mail. The output records will normally be made available for mailing ten work days after receipt of the customer order or at an interval mutually agreed upon. Availability may be delayed in case of input errors in the customer provided order.
- (F) The customer may request data be transmitted. Data transmission charges will be determined on an ICB. Data transmission hardware and software specifications will be mutually agreed upon by the Telephone Company and the customer.
- (G) BNA and DGS detail will not be retained by the Telephone Company longer than 45 days. If the customer requests that the output be made available on a second occasion, such request must occur within 30 days from the date the first list was made.

WN U-16
Zipty Fiber

Original Sheet 464

FACILITIES FOR INTRASTATE ACCESS

6. MISCELLANEOUS SERVICES (Cont'd)

6.8 Billing Name and Address Services (BNAS) (Cont'd)

6.8.1 BNA and Data Gathering Services (Cont'd)

- (H) Any customer, provided BNA or DGS pursuant to this tariff, agrees to abide by all applicable rules, decisions, orders, statutes and laws concerning the disclosure of published and nonpublished telephone numbers, and further agrees to use the information contained therein only for the purpose of billing for services provided to their end users.
- (I) In no case shall any customer or authorized billing and collection agent of a customer disclose the billing name and address information of any subscriber to any third party, except that a customer may disclose BNA/DGS information to its authorized billing and collection agent or to governmental law enforcement agencies.
- (J) Conditions regarding refusal or discontinuance of this service are found in 2.1.8.

WN U-16
Zipty Fiber

Original Sheet 465

FACILITIES FOR INTRASTATE ACCESS

6. MISCELLANEOUS SERVICES (Cont'd)

6.8 Billing Name and Address Services (BNAS) (Cont'd)

6.8.2 End User Validation List

End User Validation Lists provide for the disclosure of all or a portion of end user/agent data available from the Telephone Company's records, to a Telecommunications Service Provider (customer), for purposes other than billing, and in compliance with the conditions specified in 47 C.F.R. § 64.1201(c)(1). In addition, End User Validation List Service is offered subject to the conditions specified in 6.8.1(I), and the following:

- (A) Standard End User Validation Lists will be provided in three (3) files, business, coin (semi-public and public paystations) and residence. Nonlisted/nonpublished information will be excluded, with the exception of nonlisted public paystations. The lists may be ordered on a state level basis, for any of the Telephone Company's jurisdictions subject to this tariff, unless prohibited by federal regulation, federal statute, state regulation or state statute. Rates for the standard End User Validation List are in 6.8.3(C).
- (B) Per calendar year, the customer may request up to two (2) lists per state for business, coin, and residence listings.
- (C) A standard format will be established by the Telephone Company. Requests for special list sorts will be limited to an end user list separating those that are presubscribed to the requesting customer, and/or those that are not. The rate, per record, applicable to special sorts is in 6.8.3(C).
- (D) Each request shall be treated as a new request. Requests for updates from previous lists will not be provided.
- (E) The customer shall have fifteen (15) business days from the date of delivery of a list to request any investigation of issues arising from the provision of the list.
- (F) End User Validation Lists will normally be provided to the customer within thirty calendar days after receipt of a request and within ten (10) business days of extraction, or at an interval mutually agreed upon. The administrative fee specified under 6.8.3(C) applies per request.
- (G) Conditions regarding refusal or discontinuance of this service are found in 2.1.8.

Issued: July 29, 2020
Issued by Zipty Fiber
By Jessica Epley, Regulatory & External Affairs Director

Effective: July 31, 2020

WN U-16
Zipty Fiber

Original Sheet 466

FACILITIES FOR INTRASTATE ACCESS

6. MISCELLANEOUS SERVICES (Cont'd)

6.8 Billing Name and Address Services (BNAS) (Cont'd)

6.8.3 Rates and Charges

	<u>Charge</u>
(A) <u>Billing Name and Address</u>	
BNA Number Found, each per call	\$.25
BNA Number Not Found, each per call	.25
Processing Fee ¹	
Paper Report, Electronic Transmission, or Magnetic Tape, each	50.00
(B) <u>Data Gathering Service</u>	
Per Record Accessed	.18
Processing Fee ¹	
Paper Report, Electronic Transmission, or Magnetic Tape, each	75.00
(C) <u>End User Validation List</u>	
Standard Sort, per record provided	.034
Special Sort, per record provided	.054
Administrative Fee	
Paper Report, Electronic Transmission, or Magnetic Tape, per request	78.00

¹ Applies once per calendar year for BNA or DGS processing done within that calendar year.

WN U-16
Zipty Fiber

Original Sheet 467

FACILITIES FOR INTRASTATE ACCESS

SECTION 7 TABLE OF CONTENTS

7.	<u>SPECIALIZED FIA OR ARRANGEMENTS</u>	<u>Sheet No.</u>
7.1	<u>General</u>	468

WN U-16
Zipty Fiber

Original Sheet 468

FACILITIES FOR INTRASTATE ACCESS

7. SPECIALIZED FIA OR ARRANGEMENTS

7.1 General

Specialized FIA or Arrangements may be provided by the Telephone Company, at the request of a customer, on an Individual Case Basis (ICB) if such FIA or arrangements meet the following criteria:

- The requested FIA or arrangements are not offered under other sections of this tariff.
- The facilities utilized to provide the requested FIA or arrangements are of a type normally used by the Telephone Company in furnishing its other services.
- The requested FIA or arrangements are provided within a LATA.
- The requested FIA or arrangements are compatible with other Telephone Company services, facilities, and its engineering and maintenance practices.

This offering is subject to the availability of the necessary Telephone Company personnel and capital resources.

WN U-16
Zipty Fiber

Original Sheet 469

FACILITIES FOR INTRASTATE ACCESS

SECTION 9 TABLE OF CONTENTS

8.	<u>SPECIAL FACILITIES ROUTING OF FIA</u>	<u>Sheet No.</u>
8.1	<u>Description of Special Facilities Routing of FIA</u>	470
8.1.1	Diversity	470
8.1.2	Avoidance	470
8.1.3	Cable-Only Facilities.....	470
8.2	<u>Rates and Charges</u>	472
8.2.1	Diversity	472
8.2.2	Avoidance	472
8.2.3	Diversity and Avoidance Combined.....	472
8.2.4	Cable-Only Facilities.....	472

WN U-16
Zipty Fiber

Original Sheet 470

FACILITIES FOR INTRASTATE ACCESS

8. SPECIAL FACILITIES ROUTING OF FIA

8.1 Description of Special Facilities Routing of FIA

The FIA provided under this tariff are provided over such routes and facilities as the Telephone Company may elect. Special routing is involved where; in order to comply with requirements specified by the customer, the Telephone Company provides Switched Access or Special Access, in a manner, which includes one or more of the following conditions.

8.1.1 Diversity

Where two or more FIA must be provided over not more than two different physical routes. Diversity is a Basic Service Element (BSE) under the Telephone Company's Open Network Architecture (ONA) Plan.

8.1.2 Avoidance

Where a FIA must be provided on a route, which avoids specified geographical locations.

8.1.3 Cable-Only Facilities

Where certain voice grade FIA are provided on cable-only facilities to meet the particular needs of a customer or end user. FIA is provided subject to the availability of cable-only facilities. In the event of FIA failure, restoration will be made through the use of any available facilities as selected by the Telephone Company.

WN U-16
Zipty Fiber

Original Sheet 471

FACILITIES FOR INTRASTATE ACCESS

8. SPECIAL FACILITIES ROUTING OF FIA (Cont'd)

8.1 Description of Special Facilities Routing of FIA (Cont'd)

Avoidance and Diversity are available on Switched Access as described in Section 4; voiceband and wideband analog Special Access as described in Section 5. Cable-only facilities are available for Switched Access as described in Section 4, voiceband Special Access as described in 5.2.1.

In order to identify any special routing requirement, the Telephone Company will provide the ordering customer with the required routing information for each specially routed FIA. If requested by the customer, this information will be provided when the FIA is installed and prior to any subsequent change in routing.

The rates and charges for Special Facilities Routing of FIA as specified in 8.2 are in addition to all other rates and charges that may be applicable for FIA provided under other sections of this tariff.

WN U-16
Zipty Fiber

Original Sheet 472

FACILITIES FOR INTRASTATE ACCESS

8. SPECIAL FACILITIES ROUTING OF FIA (Cont'd)

8.2 Rates and Charges

The rates and charges for Special Facilities Routing of FIA are as follows:

8.2.1 Diversity

For each FIA provided in accordance with 8.1.1, the rates and charges will be developed on an Individual Case Basis and filed following:

(Reserved for Future Use)

8.2.2 Avoidance

For each FIA provided in accordance with 8.1.2, the rates and charges will be developed on an Individual Case Basis and filed following:

(Reserved for Future Use)

8.2.3 Diversity and Avoidance Combined

For each FIA provided in accordance with 8.1.1 and 8.1.2, combined, the rates and charges will be developed on an Individual Case Basis and filed following:

(Reserved for Future Use)

8.2.4 Cable-Only Facilities

For each FIA provided in accordance with 8.1.3, the rates and charges will be developed on an Individual Case Basis and filed following:

(Reserved for Future Use)

WN U-16
Zipty Fiber

Original Sheet 473

FACILITIES FOR INTRASTATE ACCESS

SECTION 9 TABLE OF CONTENTS

9. SPECIAL CONSTRUCTION	<u>Sheet No.</u>
9.1 <u>General</u>	475
9.1.1 Conditions Requiring Special Construction.....	475
9.1.2 Ownership of Facilities.....	476
9.1.3 Interval to Provide FIA	476
9.1.4 Special Construction Involving Interstate and Intrastate FIA	476
9.2 <u>Liabilities, Charges and Payments</u>	477
9.2.1 General	477
9.2.2 Payment of Charges	477
9.2.3 Start/End of Billing	477
9.2.4 Partial Payments.....	478
9.2.5 Development of Liabilities and Charges	479
9.2.6 Types of Contingent Liabilities	480
(A) Maximum Termination Liability	480
9.2.7 Types of Charges	483
(A) Nonrecurring Charges.....	483
(1) Case Preparation Charge	483
(2) Termination Charge	483
(3) Cancellation Charge	484
(4) Expediting Charge	485
(5) Optional Payment Charge.....	485
(a) Development of Optional Payment Charge.....	486
(b) Replacement Charge	489
(B) Recurring Charges.....	490
(1) Excess Capacity Charge.....	490
(2) Charge for Route or Type Other Than Normal	493
(3) Lease Charge	497

WN U-16
ZiPLY Fiber

Original Sheet 474

FACILITIES FOR INTRASTATE ACCESS

SECTION 10 TABLE OF CONTENTS

9.	<u>SPECIAL CONSTRUCTION</u> (Cont'd)	<u>Sheet No.</u>
9.2	<u>Liabilities, Charges and Payments</u> (Cont'd)	
9.2.8	Application of Charges.....	498
	(A) Special Construction of Permanent FIA.....	498
	(1) Special Construction When Not Available and There is No Other Requirement for Them	498
	(2) Special Construction Using a Route or Type of FIA Other Than Normal	498
	(3) Special Construction of a Greater Quantity of FIA Than Necessary to Satisfy the Customer's Order for Service .	499
	(4) Special Construction Expedited at Greater Cost Than Would Otherwise be Incurred	499
	(B) Special Construction of Temporary FIA Order	499
9.3	<u>Deferral of the In-Service of FIA</u>	500
	9.3.1 General	500
	9.3.2 Construction Has Not Started.....	500
	9.3.3 Construction Has Started But is Not Complete	501
	(A) All FIA Are Deferred.....	501
	(B) Some But Not All FIA Are Deferred	501
	9.3.4 Construction Complete	501

WN U-16
Zipty Fiber

Original Sheet 475

FACILITIES FOR INTRASTATE ACCESS

9. SPECIAL CONSTRUCTION

9.1 General

This section contains the regulations applicable for Special Construction of Telephone Company facilities which are used to provide FIA offered under this tariff.

When Special Construction of FIA is required, the provisions of this section apply in addition to regulations, rates and charges specified in other sections of this tariff.

9.1.1 Conditions Requiring Special Construction

Special Construction is required when facilities are not available to meet a customer's ASR and one or more of the following conditions exist:

- The Telephone Company has no other requirement for the facilities constructed at the customer's request;
- The customer requests that FIA be furnished using a type of facility, or via a route, other than that which the Telephone Company would otherwise utilize in furnishing the requested FIA;
- The customer requests the construction of more facilities than is required to satisfy its ASR;
- The customer requests construction be expedited resulting in added cost to the Telephone Company;
- The customer requests that temporary facilities be constructed until permanent facilities are available.
- The customer requests construction of permanent facilities to be used for temporary Video broadcast service.

WN U-16
ZiPLY Fiber

Original Sheet 476

FACILITIES FOR INTRASTATE ACCESS

9. SPECIAL CONSTRUCTION (Cont'd)

9.1 General (Cont'd)

9.1.2 Ownership of Facilities

The Telephone Company retains ownership of all specially constructed facilities, except for those facilities constructed by connecting companies or carriers, even though the customer may be required to pay Special Construction charges.

9.1.3 Interval to Provide FIA

Based on available information and the type of FIA ordered, the Telephone Company will establish a scheduled date for the installation of necessary facilities. The date will be established on an Individual Case Basis and provided to the customer. The Telephone Company will make every reasonable effort to assure that the date is met. However, circumstances beyond the Telephone Company's control (e.g., backorder of components) may force a reschedule, and a new completion date will be established with the customer when appropriate.

9.1.4 Special Construction Involving Interstate and Intrastate FIA

When Special Construction involves facilities used to provide both interstate and intrastate FIA, charges for the portion of the construction used to provide intrastate FIA shall be in accordance with this tariff. Charges for the portion of the construction used to provide interstate FIA shall be in accordance with the appropriate Telephone Company tariff providing Facilities for Interstate Access.

WN U-16
Zipty Fiber

Original Sheet 477

FACILITIES FOR INTRASTATE ACCESS

9. SPECIAL CONSTRUCTION (Cont'd)

9.2 Liabilities, Charges and Payments

9.2.1 General

This section describes the various charges and liabilities that apply when the Telephone Company provides Special Construction of FIA, as outlined in 9.1.1, in accordance with a customer's specific request. Once the customer is notified of all charges and liabilities, the customer must provide the Telephone Company with written approval prior to the start of construction. If more than one condition requiring Special Construction is involved, charges for each condition apply (see Conditions Requiring Special Construction, 9.1.1).

9.2.2 Payment of Charges

Payment is due upon presentation of a bill for the specially constructed facilities.

9.2.3 Start/End of Billing

Billing of recurring charges for specially constructed FIA starts on the day after the FIA are provided. Billing accrues through and includes the day that the specially constructed FIA are discontinued. Monthly charges will be billed one month in advance.

WN U-16
Zipty Fiber

Original Sheet 478

FACILITIES FOR INTRASTATE ACCESS

9. SPECIAL CONSTRUCTION (Cont'd)

9.2 Liabilities, Charges and Payments (Cont'd)

9.2.4 Partial Payments

The Telephone Company will require a customer, which has a proven history of late payments to the Telephone Company, or does not have established credit, to make a partial payment for the portion of the estimated cost of the Special Construction for which the customer is subject to a nonrecurring charge. Partial payments will be requested as costs are incurred and will be credited to the customer's account. Partial payments will not exceed the total nonrecurring charge to the customer for the Special Construction.

Issued: July 29, 2020
Issued by Zipty Fiber
By Jessica Epley, Regulatory & External Affairs Director

Effective: July 31, 2020

WN U-16
Zipty Fiber

Original Sheet 479

FACILITIES FOR INTRASTATE ACCESS

9. SPECIAL CONSTRUCTION (Cont'd)

9.2 Liabilities, Charges and Payments (Cont'd)

9.2.5 Development of Liabilities and Charges

The customer has the option of accepting the liabilities and charges based on estimated or actual costs. Estimated costs will be used unless the customer notifies the Telephone Company of the selection of the actual cost option in writing prior to the start of Special Construction.

Under the estimated cost option, Special Construction liabilities and charges are developed based on estimated costs.

Under the actual cost option, if all actual costs are not available prior to the in-service date of the FIA, estimated Special Construction charges will be applied. As soon as the actual costs are subsequently determined, the estimated charges will be adjusted to reflect the actual costs.

WN U-16
Zipty Fiber

Original Sheet 480

FACILITIES FOR INTRASTATE ACCESS

9. SPECIAL CONSTRUCTION (Cont'd)

9.2 Liabilities, Charges and Payments (Cont'd)

9.2.6 Types of Contingent Liability

Depending on the specifics associated with each individual case the following Maximum Termination Liability may be applicable for Special Construction.

(A) Maximum Termination Liability

A MTL has two components, an amount and a specified period of time.

The amount is equal to all nonrecoverable costs less the net salvage value (e.g., depreciation, return, income tax associated with the specially constructed facilities). The amount will be amortized over the average account life of the specially constructed facilities. The standard liability period is the average account life of the Specially Constructed facilities expressed in years.

WN U-16
Zipty Fiber

Original Sheet 481

FACILITIES FOR INTRASTATE ACCESS

9. SPECIAL CONSTRUCTION (Cont'd)

9.2 Liabilities, Charges and Payments (Cont'd)

9.2.6 Types of Contingent Liability (Cont'd)

(A) Maximum Termination Liability (Cont'd)

At the customer's option, an optional liability period shorter than the average account life may be established. If the customer chooses an optional liability period, the MTL amortization schedule will not change. The remaining MTL amount for the period between the expiration of the optional liability period and the expiration of the amortization schedule will be due as a lump sum payment (LS) at the time the optional liability period expires unless the case of Special Construction is extended.

Prior to the expiration of an optional liability period, the customer has the option to (A) extend the use of the specially constructed FIA establishing a new liability period, or (B) terminate the case of Special Construction and pay the lump sum payment.

WN U-16
Zipty Fiber

Original Sheet 482

FACILITIES FOR INTRASTATE ACCESS

9. SPECIAL CONSTRUCTION (Cont'd)

9.2 Liabilities, Charges and Payments (Cont'd)

9.2.6 Types of Contingent Liability (Cont'd)

(A) Maximum Termination Liability (Cont'd)

The Telephone Company will notify the customer six months in advance of the expiration date of the optional liability period. The customer must provide the Telephone Company with written notification of its intentions to be received one month prior to expiration of the optional liability period. Failure to do so, and payment of the next month's charges, will result in extension of the case of the Special Construction and the establishment of a new liability period equal to the remaining amortization period. A Case Preparation Charge will always apply if the Special Construction case is extended.

WN U-16
Zipty Fiber

Original Sheet 483

FACILITIES FOR INTRASTATE ACCESS

9. SPECIAL CONSTRUCTION (Cont'd)

9.2 Liabilities, Charges and Payments (Cont'd)

9.2.7 Types of Charges

Two categories of charges may be applicable for Special Construction. These charges are nonrecurring charges and recurring charges. These categories are described below.

(A) Nonrecurring Charges

One or more of the following nonrecurring charges may apply for each case of Special Construction: case preparation, termination, cancellation, expediting the construction, or optional payment charges.

(1) Case Preparation Charge

The charge for case preparation includes the administrative expense associated with preparing the charges.

(2) Termination Charge

A Termination Charge applies when, at the customer's request, FIA provided on specially constructed facilities which have a Maximum Termination Liability are discontinued prior to the expiration of the liability period.

WN U-16
Zipty Fiber

Original Sheet 484

FACILITIES FOR INTRASTATE ACCESS

9. SPECIAL CONSTRUCTION (Cont'd)

9.2 Liabilities, Charges and Payments (Cont'd)

9.2.7 Types of Charges (Cont'd)

(A) Nonrecurring Charges (Cont'd)

(2) Termination Charge (Cont'd)

The charge reflects the unamortized portion of the nonrecoverable cost at the time of termination of the specially constructed FIA adjusted for tax effects, for net salvage and for possible reuse. Administrative costs associated with the specific case of Special Construction and any cost for restoring a location to its original condition are also included. Termination Charges will never exceed the MTL.

(3) Cancellation Charge

If the customer cancels an ASR with which Special Construction is associated prior to the in-service date of the FIA, a Cancellation Charge will apply.

The charge will include all nonrecoverable costs less the net salvage value incurred by the Telephone Company up to and including the time of cancellation.

WN U-16
Zipty Fiber

Original Sheet 485

FACILITIES FOR INTRASTATE ACCESS

9. SPECIAL CONSTRUCTION (Cont'd)

9.2 Liabilities, Charges and Payments (Cont'd)

9.2.7 Types of Charges (Cont'd)

(A) Nonrecurring Charges (Cont'd)

(4) Expediting Charge

An Expediting Charge applies when a customer requests that Special Construction be completed on an expedited basis. The charge is equal to the difference in the estimated cost of construction on an expedited basis and construction without expediting.

(5) Optional Payment Charge

The customer may elect to pay an Optional Payment Charge when it requests Special Construction of facilities utilizing (1) a type of facilities or (2) a route other than that which the Telephone Company would otherwise utilize in furnishing the requested service. Payment of this charge will result in a lower recurring charge for the Special Construction. This election must be made in writing, before Special Construction starts.

If this election is coupled with the actual cost option, the Optional Payment Charge will reflect the actual cost of the specially constructed facilities.

WN U-16
ZiPLY Fiber

Original Sheet 486

FACILITIES FOR INTRASTATE ACCESS

9. SPECIAL CONSTRUCTION (Cont'd)

9.2 Liabilities, Charges and Payments (Cont'd)

9.2.7 Types of Charges (Cont'd)

(A) Nonrecurring Charges (Cont'd)

(5) Optional Payment Charge (Cont'd)

(a) Development of Optional Payment Charge

This charge is equal to the excess installed cost or the total nonrecoverable cost, whichever is less (based on estimated or actual costs as elected by the customer).

Example 1:

Total Installed Cost	\$ 30,000
Nonrecoverable	20,000
Normal Installed Cost	17,000
Total Installed Cost	\$ 30,000
Minus Normal Installed Cost	17,000
Equals Excess Installed Cost	13,000
Optional Payment Charge	13,000
Nonrecoverable Cost	\$ 20,000
Minus Optional Payment Charge	13,000
Equals Investment for MTL	
Computation	7,000
Remaining Recoverable	
Excess Installed Cost	\$ 0

WN U-16
Zipty Fiber

Original Sheet 487

FACILITIES FOR INTRASTATE ACCESS

9. SPECIAL CONSTRUCTION (Cont'd)

9.2 Liabilities, Charges and Payments (Cont'd)

9.2.7 Types of Charges (Cont'd)

(A) Nonrecurring Charges (Cont'd)

(5) Optional Payment Charge (Cont'd)

(a) Development of Optional Payment Charge (Cont'd)

Since the total installed cost is \$30,000 and the normal installed cost would have been \$17,000, the nonrecurring charge (optional payment) is limited to the difference (i.e., \$13,000). A Maximum Termination Liability would then be established to protect the remaining nonrecoverable cost of \$7,000 which is the difference between the total nonrecoverable cost (\$20,000) and the nonrecurring charge (\$13,000). The remaining excess installed cost in this example is zero. In addition, a recurring charge will be developed as specified in 9.2.7(B).

WN U-16
Zipty Fiber

Original Sheet 488

FACILITIES FOR INTRASTATE ACCESS

9. SPECIAL CONSTRUCTION (Cont'd)

9.2 Liabilities, Charges and Payments (Cont'd)

9.2.7 Types of Charges (Cont'd)

(A) Nonrecurring Charges (Cont'd)

(5) Optional Payment Charge (Cont'd)

(a) Development of Optional Payment Charge (Cont'd)

Example 2:

Total Installed Cost	\$ 30,000
Nonrecoverable Cost	10,000
Normal Installed Cost	17,000
Total Installed Cost	\$ 30,000
Minus Normal Installed Cost	17,000
Equals Excess Installed Cost	13,000
Optional Payment Charge	10,000
Nonrecoverable Cost	\$ 10,000
Minus Optional Payment Charge	10,000
Equals Investment for MTL Computation	0
Remaining Recoverable Excess Installed Cost	\$ 3,000

The Optional Payment Charge is limited to the nonrecoverable cost. In this example the Optional Payment Charge equals the nonrecoverable cost. Therefore, there is no Maximum Termination Liability. In addition, a recurring charge will be developed as described in 9.2.7(B).

WN U-16
ZiPLY Fiber

Original Sheet 489

FACILITIES FOR INTRASTATE ACCESS

9. SPECIAL CONSTRUCTION (Cont'd)

9.2 Liabilities, Charges and Payments (Cont'd)

9.2.7 Types of Charges (Cont'd)

(A) Nonrecurring Charges (Cont'd)

(5) Optional Payment Charge (Cont'd)

(b) Replacement Charge

If any portion of the specially constructed FIA, for which an Optional Payment Charge has been paid, requires replacement involving capital investment, a charge for replacement will apply. This charge will be in the same ratio as the initial Optional Payment Charge was to the installed cost of the specially constructed FIA. The customer will be notified in writing that the replacement is required. Replacement will not be made without the customer's ASR. If any portion of the FIA subject to the replacement charge fails, the FIA will not be restored until the customer orders the replacement.

Example:

Original Total Installed Cost	\$30,000
Original Optional Payment Charge	\$15,000
Subsequent Cost of Replacement	\$ 2,000

$$\frac{\text{Original Optional Payment Charge} \times \text{Replacement Cost}}{\text{Total Installed Cost}}$$

$$\frac{\$15,000 \times \$2,000}{\$30,000} = 1,000$$

Replacement Charge	\$ 1,000
--------------------	----------

WN U-16
Zipty Fiber

Original Sheet 490

FACILITIES FOR INTRASTATE ACCESS

9. SPECIAL CONSTRUCTION (Cont'd)

9.2 Liabilities, Charges and Payments (Cont'd)

9.2.7 Types of Charges (Cont'd)

(B) Recurring Charges

These charges apply on a monthly or annual basis for specially constructed FIA. There are three conditions for which recurring charges apply:

- when a customer requests the construction of more facilities than are necessary to provide the FIA currently ordered.
- when a customer requests a facility route or type other than that which the Telephone Company would utilize to provide FIA.
- when a customer's request results in the Telephone Company leasing transmission or other equipment from private vendors to provide a FIA (Lease Charge).

(1) Excess Capacity Charge

An Excess Capacity Charge applies when the customer requests more facilities be constructed than are required to satisfy the customer's ASR. The charge is based on the estimated cost difference between the facilities constructed at the customer's request and the facilities actually required to meet the customer's ASR.

WN U-16
ZiPLY Fiber

Original Sheet 491

FACILITIES FOR INTRASTATE ACCESS

9. SPECIAL CONSTRUCTION (Cont'd)

9.2 Liabilities, Charges and Payments (Cont'd)

9.2.7 Types of Charges (Cont'd)

(B) Recurring Charges (Cont'd)

(1) Excess Capacity Charge (Cont'd)

Example:

A customer has an immediate FIA requirement which would require a 100 pair cable but requests the installation of a 300 pair cable to allow for growth.

Total Installed Cost (300 Pair)	\$ 2,500
Estimated Annual Cost	920
Estimated Installed Cost (100 Pair)	1,000
Estimated Annual Cost	368

Excess Recurring Charge:

$$\text{Annually } \$920 - \$368 = \$552$$

$$\text{Monthly } \frac{\$552}{12} = \$46$$

This charge applies until such time as the customer orders sufficient FIA to necessitate use of a larger size cable (e.g., 200 pair cable). At that time the recurring charge is adjusted as indicated in the following example:

Total Installed Cost (300 Pair)	\$ 2,500
Estimated Annual Cost	920
Estimated Installed Cost (200 Pair)	1,900
Estimated Annual Cost	683

Excess Recurring Charge:

$$\text{Annually } \$920 - \$683 = \$237$$

$$\text{Monthly } \frac{\$237}{12} = \$19.75$$

WN U-16
Zipty Fiber

Original Sheet 492

FACILITIES FOR INTRASTATE ACCESS

9. SPECIAL CONSTRUCTION (Cont'd)

9.2 Liabilities, Charges and Payments (Cont'd)

9.2.7 Types of Charges (Cont'd)

(B) Recurring Charges (Cont'd)

(1) Excess Capacity Charge (Cont'd)

The charge is revised in this manner until the number of FIA being provided would require a 300 pair cable, at which time the Excess Capacity Charge is no longer applied. The charge would be reapplied if the number of FIA declined to a level which would not require a 300 pair cable.

Such charges will continue to apply to all facilities held in abeyance until the period of termination liability expires. If facilities are still held in abeyance after the termination liability expires, a new schedule of rates will be calculated and such rates will apply as long as facilities are held in abeyance for the customer.

WN U-16
Zipty Fiber

Original Sheet 493

FACILITIES FOR INTRASTATE ACCESS

9. SPECIAL CONSTRUCTION (Cont'd)

9.2 Liabilities, Charges and Payments (Cont'd)

9.2.7 Types of Charges (Cont'd)

(B) Recurring Charges (Cont'd)

(2) Charge for Route or Type Other Than Normal

When the customer requests Special Construction using a route or type of FIA other than that which the Telephone Company would normally use, a recurring charge is applicable. The charge is the difference between the estimated recurring costs of the specially constructed FIA and the estimated recurring costs of the FIA the Telephone Company would normally use. The charge will be no greater than the recurring costs of the specially constructed FIA.

WN U-16
Zipty Fiber

Original Sheet 494

FACILITIES FOR INTRASTATE ACCESS

9. SPECIAL CONSTRUCTION (Cont'd)

9.2 Liabilities, Charges and Payments (Cont'd)

9.2.7 Types of Charges (Cont'd)

(B) Recurring Charges (Cont'd)

(2) Charge for Route or Type Other Than Normal (Cont'd)

- (a) If the customer elects to pay an Optional Payment Charge, the portion of the recurring charge for the excess investment covered by the optional payment excludes capital cost items (depreciation, return on investment and Federal Income Tax on that return). The remaining recurring expense cost items associated with the optional payment (maintenance, administration, and other taxes) are increased by a ten percent management fee and will be included in the recurring charge.

The portion of any recurring charge associated with any remaining Special Construction investment will include both capital and expense costs. The ten percent management fee is not applied to this portion of the recurring charge.

WN U-16
Zipty Fiber

Original Sheet 495

FACILITIES FOR INTRASTATE ACCESS

9. SPECIAL CONSTRUCTION (Cont'd)

9.2 Liabilities, Charges and Payments (Cont'd)

9.2.7 Types of Charges (Cont'd)

(B) Recurring Charges (Cont'd)

(2) Charge for Route or Type Other Than Normal (Cont'd)

(a) (Cont'd)

DEVELOPMENT OF RECURRING MONTHLY CHARGE FOR OPTIONAL PAYMENTS

For example 1 see 9.2.7(A)(6)(a)

	<u>SPECIAL ROUTE OR TYPE OF FIA</u>			<u>NORMAL</u>
	A	B	C	D
Optional Payment				
Nonrecurring Charge For Special Const. FIA	\$13,000	Specially Constructed FIA Less Nonrecurring Charges	Existing Facilities	Normal Route/Type Facilities
		\$17,000		\$17,000
1. Depreciation	-	1,122		408
2. Federal Income Tax and Return	-	2,142		2,346
3. Maintenance	1,131	1,479		799
4. Administration	455	595		595
5. Other Taxes	286	37		374
6. Sub Total	1,872	-	-	-
7. 10% x Line 6	187	-	-	-
8. Totals	(A) \$ 2,059	(B) \$ 5,712	(C)	(D) \$ 4,522

A + B = \$7,771
A + B + C = 7,771
(A + B + C) - D = 3,249

Excess Recurring Charge:¹ Annually \$3,249.00
Monthly \$ 270.75

¹ The lowest of (A+B+C)-D, or (A+B)

WN U-16
Zipty Fiber

Original Sheet 496

FACILITIES FOR INTRASTATE ACCESS

9. SPECIAL CONSTRUCTION (Cont'd)

9.2 Liabilities, Charges and Payments (Cont'd)

9.2.7 Types of Charges (Cont'd)

(B) Recurring Charges (Cont'd)

(2) Charge for Route or Type Other Than Normal (Cont'd)

(a) (Cont'd)

DEVELOPMENT OF RECURRING MONTHLY CHARGE FOR OPTIONAL PAYMENTS

For example 2 see 9.2.7(A)(6)(a)

	<u>SPECIAL ROUTE OR TYPE OF FIA</u>			<u>NORMAL</u>
	A	B	C	D
Optional Payment				
Nonrecurring Charge For Special Const. FIA	\$10,000	Specially Constructed FIA Less Nonrecurring Charges	Existing Facilities	Normal Route/Type Facilities
		\$20,000		\$17,000
1. Depreciation	-	1,320		408
2. Federal Income Tax and Return	-	2,520		2,346
3. Maintenance	870	1,740		799
4. Administration	350	700		595
5. Other Taxes	220	440		374
6. Sub Total	1,440	-	-	-
7. 10% x Line 6	144	-	-	-
8. Totals	(A) \$ 1,584	(B) \$ 6,720	(C)	(D) \$ 4,522

A + B = \$8,304
A + B + C = 8,304
(A + B + C) - D = 3,782

Excess Recurring Charge:¹ Annually \$3,782.00
Monthly \$ 315.17

¹ The lowest of (A+B+C)-D, or (A+B)

WN U-16
Zipty Fiber

Original Sheet 497

FACILITIES FOR INTRASTATE ACCESS

9. SPECIAL CONSTRUCTION (Cont'd)

9.2 Liabilities, Charges and Payments (Cont'd)

9.2.7 Types of Charges (Cont'd)

(B) Recurring Charges (Cont'd)

(2) Charge for Route or Type Other Than Normal (Cont'd)

- (b) If the customer has elected the actual cost option, the recurring charge will be adjusted to reflect the actual cost of the new construction when the cost is determined. This adjusted recurring charge is applicable from the start of FIA.

(3) Lease Charge

A Lease Charge applies when the Telephone Company leases equipment (e.g., portable microwave equipment) in order to provide FIA to meet the customer's requirements. The amount of the charge is the net added cost to the Telephone Company caused by the lease.

WN U-16
Zipty Fiber

Original Sheet 498

FACILITIES FOR INTRASTATE ACCESS

9. SPECIAL CONSTRUCTION (Cont'd)

9.2 Liabilities, Charges and Payments (Cont'd)

9.2.8 Application of Charges

The charges for Special Construction are those charges which are in effect for the period that the Special Construction is furnished. If the charges for a period covered by a bill change after the bill has been rendered, the bill will be adjusted to reflect the new charges. Charges are based on Special Construction of (A) permanent FIA or (B) temporary FIA.

(A) Special Construction of Permanent FIA

(1) Special Construction when Not Available and There is No Other Requirement for Them

When permanent FIA are not available and the Telephone Company constructs them and there is no other Telephone Company need for the specially constructed FIA, a nonrecurring charge, and a Maximum Termination Liability may be applicable.

(2) Special Construction Using a Route or Type of FIA Other Than Normal

When the specially constructed FIA involve a route or type of FIA other than that which the Telephone Company would ordinarily use, charges are based on the difference between the estimated costs of the specially constructed FIA and those the Telephone Company would ordinarily use. A nonrecurring charge, a recurring charge, and a Maximum Termination Liability may be applicable.

WN U-16
Zipty Fiber

Original Sheet 499

FACILITIES FOR INTRASTATE ACCESS

9. SPECIAL CONSTRUCTION (Cont'd)

9.2 Liabilities, Charges and Payments (Cont'd)

9.2.8 Application of Charges (Cont'd)

(A) Special Construction of Permanent FIA (Cont'd)

(3) Special Construction of a Greater Quantity of FIA Than Necessary to Satisfy the Customer's Order for Service

When the Telephone Company constructs more FIA than is required to satisfy the customer's ASR, additional charges will apply. These charges may include a nonrecurring charge, a recurring charge, and a Maximum Termination Liability.

(4) Special Construction Expedited at Greater Cost Than Would Otherwise be Incurred

When construction is expedited resulting in added costs, a nonrecurring Expediting Charge applies.

(B) Special Construction of Temporary FIA Order

When permanent FIA are not available and temporary FIA are constructed pending the construction of permanent FIA, a nonrecurring charge, and a Maximum Termination Liability may be applicable.

WN U-16
Zipty Fiber

Original Sheet 500

FACILITIES FOR INTRASTATE ACCESS

9. SPECIAL CONSTRUCTION (Cont'd)

9.3 Deferral of the In-Service of FIA

9.3.1 General

The customer may request the Telephone Company to defer the in-service of FIA on specially constructed FIA subject to the provisions as specified in 3.2.2(B). If the deferral is not in compliance with the provisions as specified in 3.2.2(B), the Special Construction case is considered to be cancelled and cancellation charges apply. Requests for deferral must be in writing and are subject to the following regulations.

9.3.2 Construction Has Not Started

If the Telephone Company has not incurred any costs (e.g., engineering and/or installation) before receiving the customer's request for deferral, no charge applies other than the Case Preparation Charge. However, the original quotation is subject to Telephone Company review at the time of reinstatement to determine if the original charges are still valid. Any change in liabilities and charges requires the concurrence of the customer in writing. Additional Case Preparation Charges will also apply.

WN U-16
Zipty Fiber

Original Sheet 501

FACILITIES FOR INTRASTATE ACCESS

9. SPECIAL CONSTRUCTION (Cont'd)

9.3 Deferral of the In-Service of FIA (Cont'd)

9.3.3 Construction Has Started But Is Not Complete

If the construction of FIA has started, but has not been completed, before the Telephone Company receives the customer's request for deferral, charges apply. The charges vary depending on whether all or some of the FIA ordered are deferred.

(A) All FIA Are Deferred

When all FIA involving Special Construction are deferred, a charge equal to the costs incurred during each month of the deferral applies. Those costs include the recurring costs for that portion of the FIA already completed and any other costs associated with the deferral. The Case Preparation Charge also applies.

(B) Some But Not All FIA Are Deferred

When some, but not all, FIA utilizing the specially constructed FIA are deferred, the Special Construction case will be completed. Maximum Termination Liability will apply in addition to Case Preparation Charges and any recurring charges associated with the Special Construction.

9.3.4 Construction Complete

If the construction of FIA has been completed before the Telephone Company receives the customer's request for deferral, the Case Preparation Charge as originally determined, will apply and any recurring charges associated with the Special Construction. The Maximum Termination Liability Period will begin when the customer accepts the service.

WN U-16
Zipty Fiber

Original Sheet 502

FACILITIES FOR INTRASTATE ACCESS

SECTION 10 TABLE OF CONTENTS

10. <u>PROMOTIONS</u>	<u>Sheet No.</u>
<u>Reserved for Future Use</u>	503

WN U-16
Zipty Fiber

Original Sheet 503

FACILITIES FOR INTRASTATE ACCESS

10. PROMOTIONS

10.1 Reserved for future use.

WN U-16
Zipty Fiber

Original Sheet 504

FACILITIES FOR INTRASTATE ACCESS

SECTION 11 TABLE OF CONTENTS

11. <u>CARRIER COMMON LINE SERVICE</u>	<u>Sheet No.</u>
11.1 <u>General Description</u>	506
11.2 <u>Description of Carrier Common Line Service</u>	506
11.2.1 Description	506
11.2.2 Limitations	506
(A) Exclusions	506
(B) WATS/WATS-type Access Lines	506
11.3 <u>Obligations of the Customer</u>	507
11.3.1 Switched Access Service Requirement	507
11.3.2 Supervision	507
11.4 <u>Rate Regulations</u>	507
11.4.1 Description and Application of Rates	507
(A) Billing of Charges	507
(B) Measuring and Recording of Call Detail	508
(C) Unmeasured FGA, FGB, BSA-A and BSA-B Usage	509
(D) Mixed Interstate and Intrastate Usage	509
(E) Determination of Premium and Nonpremium Charges	510
11.4.2 Determination of Usage Subject to Carrier Common Line Charges	513
(A) Determination of Jurisdiction	513
(B) Cases Involving Usage Recording by the Customer	513

WN U-16
ZiPLY Fiber

Original Sheet 505

FACILITIES FOR INTRASTATE ACCESS

SECTION 11 TABLE OF CONTENTS

11.	<u>CARRIER COMMON LINE SERVICE</u> (Cont'd)	<u>Sheet No.</u>
11.4	<u>Rate Regulations</u> (Cont'd)	
11.4.3	Resold Services.....	514
	(A) Scope	514
	(B) Customer Obligations Concerning the Resale of MTS/WATS-type Services	515
	(C) Resale Documentation Provided by the Customer.....	515
	(D) Rate Regulations Concerning the Resale of MTS/WATS-type Services	516
	(1) Apportionment and Adjustment of Resold Minutes of Use	516
	(a) Originating Services.....	516
	(b) Terminating Services	517
	(2) Same State/Telephone Company/Exchange Limitation	518
	(3) Direct and Indirect Connections	519
	(4) Access Groups and BSAs - Nonequal Access Offices Only ...	521
	(5) Access Groups and BSAs - Equal Access Offices Only.....	522
	(6) Access Groups and BSAs - Nonequal Access and Equal Access Offices	523
	(7) When the Adjustment Will Be Applied to Customer Bills.....	524
	(8) Conversion of Billed Usage to Minutes.....	524
	(9) Mixed Interstate and Intrastate Usage.....	524
11.5	<u>Rates and Charges</u>	525

WN U-16
ZiPLY Fiber

Original Sheet 506

FACILITIES FOR INTRASTATE ACCESS

11. CARRIER COMMON LINE SERVICE

11.1 General Description

Carrier Common Line charges are applicable with Switched Access under Section 4 of this tariff.

11.2 Description of Carrier Common Line Service

11.2.1 Description

Carrier Common Line charges compensate the Telephone Company for the use of Telephone Company provided common lines by customers for access to end users in furnishing intrastate communications.

11.2.2 Limitations

(A) Exclusions

Neither telephone number nor detail billing are provided with Carrier Common Line access. Additionally, Directory Listings and Intercept arrangements are not included in the rates and charges for Carrier Common Line access.

(B) WATS/WATS-type Access Lines

Where Switched Access Services are connected with Special Access Services at Telephone Company designated WATS Serving Offices for the provision of WATS/WATS-type Services, Switched Access Service minutes which are carried on that end of the service (i.e., originating minutes for outward WATS/WATS-type services and terminating minutes for inward WATS/WATS-type services) shall not be assessed Carrier Common Line per minute charges with the following exception. Carrier Common Line per minute charges shall apply when FGA, FGB, BSA-A or BSA-B Switched Access is ordered from a nonequal access Telephone Company end office or access tandem that does not have measurement capabilities, (i.e., cannot create an Automatic Message Automatic record).

Issued: July 29, 2020
Issued by ZiPLY Fiber
By Jessica Epley, Regulatory & External Affairs Director

Effective: July 31, 2020

WN U-16
Zipty Fiber

Original Sheet 507

FACILITIES FOR INTRASTATE ACCESS

11. CARRIER COMMON LINE SERVICE (Cont'd)

11.3 Obligations of the Customer

11.3.1 Switched Access Service Requirement

Switched Access Service associated with the Carrier Common Line charges shall be ordered by the customer under other sections of this tariff.

11.3.2 Supervision

The customer facilities at the premises of the ordering customer shall provide the necessary on-hook supervision.

11.4 Rate Regulations

11.4.1 Description and Application of Rates

(A) Billing of Charges

Carrier Common Line charges will be billed to each Switched Access Service provided under this tariff in accordance with the regulations as specified in (E), except as specified in (D) and 11.4.3(D).

WN U-16
Zipty Fiber

Original Sheet 508

FACILITIES FOR INTRASTATE ACCESS

11. CARRIER COMMON LINE SERVICE (Cont'd)

11.4 Rate Regulations (Cont'd)

11.4.1 Description and Application of Rates (Cont'd)

(B) Measuring and Recording of Call Detail

When access minutes are used to determine Carrier Common Line charges, they will be accumulated using call detail recorded by Telephone Company equipment except as described in (C) and FGC or BSA-C operator and automated operator services systems call detail such as pay telephone sent-paid, operator-DDD, operator-person, collect, credit card, third number and/or other like calls recorded by the customer. The Telephone Company measuring and recording equipment, except as described in (C), will be associated with end office or access tandem switching equipment and will record each originating and terminating access minute, as described in 4.5.2(I), where answer supervision is received. The accumulated access minutes will be summed on a line by line or trunk by trunk basis, by access group or by end office, whichever type of account is used by the Telephone Company, for each customer and then rounded to the nearest minute.

WN U-16
Zipty Fiber

Original Sheet 509

FACILITIES FOR INTRASTATE ACCESS

11. CARRIER COMMON LINE SERVICE (Cont'd)

11.4 Rate Regulations (Cont'd)

11.4.1 Description and Application of Rates (Cont'd)

(C) Unmeasured FGA, FGB, BSA-A and BSA-B Usage

When Carrier Common Line charges are applicable in association with FGA, FGB, BSA-A or BSA-B Switched Access Service in Telephone Company offices that are not equipped for measurement capabilities, an assumed average intrastate access minutes will be used to determine Carrier Common Line charges. These assumed access minutes are in 4.5.2(1)(3).

(D) Mixed Interstate and Intrastate Usage

When the customer reports interstate and intrastate use of Switched Access Service, Carrier Common Line charges, in 12.5, will be billed only to intrastate Switched Access Service access minutes based on the data reported by the customer in 4.3.2 and 4.5.2(D), except where the Telephone Company is billing according to actual usage by jurisdiction. Intrastate Switched Access Service access minutes will, after adjustments as described in 12.4.3(D), when necessary, be used to determine Carrier Common Line charges as specified in (E).

WN U-16
Zipty Fiber

Original Sheet 510

FACILITIES FOR INTRASTATE ACCESS

11. CARRIER COMMON LINE SERVICE (Cont'd)

11.4 Rate Regulations (Cont'd)

11.4.1 Description and Application of Rates (Cont'd)

(E) Determination of Premium and Nonpremium Charges

The application of premium and nonpremium rates for a specific customer, as described in 4.5.2(H)(1), is dependent upon the Switched Access feature group and the availability of equal access capabilities in the end office or the WATS Serving Office from which the service is provided.

After the adjustments in (D) and 11.4.3(D), have been applied, when necessary, to Switched Access Service access minutes, charges for the involved customer account will be determined as follows:

- (1) Premium rated Switched Access Service minutes subject to Carrier Common Line charges will be multiplied by the premium access per minute rate in 11.5.
- (2) Nonpremium rated Switched Access Service minutes subject to Carrier Common Line charges will be multiplied by the nonpremium access per minute rate in 11.5.
- (3) Carrier Common Line charges shall not be reduced, as described in 11.4.3(A), unless Switched Access charges in Section 4, are applied to the customer's Switched Access Services.

WN U-16
Zipty Fiber

Original Sheet 511

FACILITIES FOR INTRASTATE ACCESS

11. CARRIER COMMON LINE SERVICE (Cont'd)

11.4 Rate Regulations (Cont'd)

11.4.1 Description and Application of Rates (Cont'd)

(E) Determination of Premium and Nonpremium Charges (Cont'd)

- (4) The terminating Premium and/or Non-premium Access, per minute charge(s) apply to:
- all terminating access minutes of use;
 - all originating access minutes of use associated with FGA or BSA-A Access Services where the off-hook supervisory signaling is forwarded by the customer's equipment when the called party answers;

WN U-16
Zipty Fiber

Original Sheet 512

FACILITIES FOR INTRASTATE ACCESS

11. CARRIER COMMON LINE SERVICE (Cont'd)

11.4 Rate Regulations (Cont'd)

11.4.1 Description and Application of Rates (Cont'd)

(E) Determination of Premium and Nonpremium Charges (Cont'd)

(5) The originating Premium and/or Non-premium Access apply to:

- all originating access minutes of use;
- less those originating access minutes of use associated with FGA or BSA-A Access Services where the off-hook supervisory signaling is forwarded by the customer's equipment when the called party answers;

WN U-16
ZiPLY Fiber

Original Sheet 513

FACILITIES FOR INTRASTATE ACCESS

11. CARRIER COMMON LINE SERVICE (Cont'd)

11.4 Rate Regulations (Cont'd)

11.4.2 Determination of Usage Subject to Carrier Common Line Charges

Except as described herein, all Switched Access Service provided to the customer will be subject to Carrier Common Line charges.

(A) Determination of Jurisdiction

When the customer reports interstate and intrastate use of Switched Access Service, the associated Carrier Common Line charges for interstate usage will be determined as described in 4.3.2 and 4.5.2(D).

(B) Cases Involving Usage Recording By the Customer

Where FGC or BSA-C end office switching is provided without Telephone Company recording and the customer records minutes of use to determine Carrier Common Line charges (i.e., FGC operator and calls such as pay telephone sent-paid, operator-DDD, operator-person, collect, credit card, third number and/or other like class), the customer shall furnish such minutes of use detail to the Telephone Company in a timely manner. If the customer does not furnish the data, the customer shall identify all Switched Access Services which could carry such calls in order for the Telephone Company to accumulate the minutes of use through the use of special Telephone Company measuring and recording equipment.

WN U-16
ZiPLY Fiber

Original Sheet 514

FACILITIES FOR INTRASTATE ACCESS

11. CARRIER COMMON LINE SERVICE (Cont'd)

11.4 Rate Regulations (Cont'd)

11.4.3 Resold Services

(A) Scope

Where the customer is reselling MTS/MTS-type service(s) on which the Carrier Common Line and Switched Access charges have been assessed, the customer may, at the option of the customer, obtain FGA, FGB, FGD, BSA-A, BSA-B, or BSA-D Switched Access Service under this tariff in Section 4, for originating and/or terminating access in the local exchange. Such access group arrangements, whether single lines or trunks or multiline hunt groups or trunk groups, will have Carrier Common Line charges in 11.5 applied in accordance with the resale rate regulations specified in (D). For purposes of administering this provision:

- Resold intrastate terminating MTS/MTS-type service(s) shall include collect calls, third number calls and credit card calls where the reseller pays the underlying carrier's service charges, and shall not include interstate minutes of use.
- Resold intrastate originating MTS/MTS-type service(s) shall not include collect, third number, credit card or interstate minutes of use.

Issued: July 29, 2020
Issued by ZiPLY Fiber
By Jessica Epley, Regulatory & External Affairs Director

Effective: July 31, 2020

WN U-16
ZiPLY Fiber

Original Sheet 515

FACILITIES FOR INTRASTATE ACCESS

11. CARRIER COMMON LINE SERVICE (Cont'd)

11.4 Rate Regulations (Cont'd)

11.4.3 Resold Services (Cont'd)

(B) Customer Obligations Concerning the Resale of MTS/MTS-type Services

When the customer is reselling MTS/MTS-type service, as described in (A), the customer will be charged Carrier Common Line charges in accordance with the resale rate regulations, as described in (D), if the customer or the provider of the MTS/MTS-type service furnishes documentation of the MTS/MTS-type services. Such documentation shall be supplied each month by the customer and shall identify the involved resold MTS/MTS-type services.

The monthly period used to determine the minutes of use for resold MTS/MTS-type service(s) shall be the most recent monthly period for which the customer has received a bill for such resold service(s). This information shall be delivered to the Telephone Company, at a location specified by the Telephone Company, no later than 15 days after the bill date shown on the resold MTS/MTS-type service bill. If the required information is not received by the Telephone Company, the previously reported information will be used for the next two months. For any subsequent month, no allocation or credit will be made until the required documentation has been received by the Telephone Company.

(C) Resale Documentation Provided by the Customer

When the customer utilizes Switched Access Service, as described in (B), the Telephone Company may request a certified copy of the customer's resold MTS/MTS-type usage billing from either the customer or the provider of the MTS/MTS-type service. Requests for billing will go back no more than 12 months prior to the current billing period.

WN U-16
ZiPLY Fiber

Original Sheet 516

FACILITIES FOR INTRASTATE ACCESS

11. CARRIER COMMON LINE SERVICE (Cont'd)

11.4 Rate Regulations (Cont'd)

11.4.3 Resold Services (Cont'd)

(D) Rate Regulations Concerning the Resale of MTS/MTS-type Services

When the customer is provided an access or BSA group to be used with the resale of MTS/MTS-type services, as described in (A), subject to the limitations, as described in 11.2.2, and the billing entity receives the usage information required, as described in (B), to calculate the adjustment of Carrier Common Line charges, the customer will be billed, as specified in (4), (5) or (6), depending upon, whether the usage is from non-equal access offices, equal access offices or a combination of the two.

(1) Apportionment and Adjustment of Resold Minutes of Use

When the customer is provided with more than one access group in a LATA in association with the resale of MTS/MTS-type services, the resold minutes of use will be apportioned as follows:

(a) Originating Services

The Telephone Company will apportion the resold originating MTS/MTS-type services and originating minutes of use for which the resale credit adjustment applies, among the access groups. Such apportionment will be based on the relationship of the originating usage for each access group to the total originating usage for all access groups in the LATA. For purposes of administering this provision:

- Resold originating MTS/MTS-type services minutes shall be only those attributable to intrastate originating MTS/MTS-type minutes and shall not include collect, third number, credit card or interstate minutes of use.

WN U-16
Zipty Fiber

Original Sheet 517

FACILITIES FOR INTRASTATE ACCESS

11. CARRIER COMMON LINE SERVICE (Cont'd)

11.4 Rate Regulations (Cont'd)

11.4.3 Resold Services (Cont'd)

(D) Rate Regulations Concerning the Resale of MTS/MTS-type Services (Cont'd)

(1) Apportionment and Adjustment of Resold Minutes of Use (Cont'd)

(a) Originating Services (Cont'd)

The resale credit adjustment shall apply for resold originating MTS/MTS-type services and minutes of use, provided Carrier Common Line and Switched Access charges have been assessed on such services.

(b) Terminating Services

The Telephone Company will apportion the resold terminating MTS/MTS-type services and terminating minutes of use for which the resale credit adjustment applies, among the access groups and BSAs. Such apportionment will be based on the relationship of the terminating usage for each access group or BSA to the total terminating usage for all access groups or BSAs in the LATA. For purposes of administering this provision:

Resold terminating MTS/MTS-type services minutes shall be only those attributable to intrastate terminating MTS/MTS-type minutes of use (i.e., collect, third number, and credit card) and shall not include interstate minutes of use or MTS/MTS-type minutes of use paid for by another party.

WN U-16
Zipty Fiber

Original Sheet 518

FACILITIES FOR INTRASTATE ACCESS

11. CARRIER COMMON LINE SERVICE (Cont'd)

11.4 Rate Regulations (Cont'd)

11.4.3 Resold Services (Cont'd)

(D) Rate Regulations Concerning the Resale of MTS/MTS-type Services (Cont'd)

(1) Apportionment and Adjustment of Resold Minutes of Use (Cont'd)

(b) Terminating Services (Cont'd)

The resale credit adjustment shall apply for resold terminating MTS/MTS-type services and minutes of use, provided Carrier Common Line and Switched Access charges have been assessed on such services.

(2) Same State/Telephone Company/Exchange Limitation

In order for the rate regulations to apply, as specified in (4), (5), (6), the access groups or BSAs and the resold MTS/MTS-type services must be provided in the same state (except when the same extended area service arrangement is provided in two different states by the same Telephone Company) in the same exchange, provided by the same Telephone Company and connected directly or indirectly. For those exchanges that encompass more than one state, the customer shall report the information by state within the exchange.

WN U-16
Zipty Fiber

Original Sheet 519

FACILITIES FOR INTRASTATE ACCESS

11. CARRIER COMMON LINE SERVICE (Cont'd)

11.4 Rate Regulations (Cont'd)

11.4.3 Resold Services (Cont'd)

(D) Rate Regulations Concerning the Resale of MTS/MTS-type Services (Cont'd)

(3) Direct and Indirect Connections

Each of the access group or BSA arrangements used by the customer in association with the resold MTS/MTS-type services must be connected either directly or indirectly to the customer designated premises at which the resold MTS/MTS-type services are terminated. Direct connections are those arrangements where the access groups and resold MTS/MTS-type services are terminated at the same customer designated premises.

Indirect originating connections are those arrangements where the access groups, BSAs and the resold originating MTS/MTS-type services are physically located at different customer designated premises in the same exchange. Such different customer designated premises are connected by facilities that permit a call to flow from access groups to resold MTS/MTS-type services.

WN U-16
ZiPLY Fiber

Original Sheet 520

FACILITIES FOR INTRASTATE ACCESS

11. CARRIER COMMON LINE SERVICE (Cont'd)

11.4 Rate Regulations (Cont'd)

11.4.3 Resold Services (Cont'd)

(D) Rate Regulations Concerning the Resale of MTS/MTS-type Services (Cont'd)

(3) Direct and Indirect Connections (Cont'd)

Indirect terminating connections are those arrangements where the access groups, BSAs and resold terminating MTS/MTS-type services are physically located at different customer designated premises in the same exchange. Such different customer designated premises are connected by facilities that permit a call to flow from resold terminating MTS/MTS-type services to access groups or BSAs.

WN U-16
ZiPLY Fiber

Original Sheet 521

FACILITIES FOR INTRASTATE ACCESS

11. CARRIER COMMON LINE SERVICE (Cont'd)

11.4 Rate Regulations (Cont'd)

11.4.3 Resold Services (Cont'd)

(D) Rate Regulations Concerning the Resale of MTS/MTS-type Services (Cont'd)

(4) Access Groups and BSAs - Nonequal Access Offices Only

The adjustments, as described here and in (5) and (6), will be computed separately for each access group and for each BSA.

When all the usage on an access group or BSA originates from and/or terminates to end offices that have not been converted to equal access, the nonpremium charge per minute, as described in 11.5, will apply. The access minutes which will be subject to Carrier Common Line charges will be the adjusted originating intrastate access minutes for such access groups or BSAs.

The adjusted originating access minutes will be the originating intrastate access minutes less the reported resold originating MTS/MTS-type service minutes of use in (1)(a), but not less than zero. The adjusted terminating access minutes will be the terminating intrastate access minutes less the reported resold terminating MTS/MTS-type service minutes of use in (1)(b), but not less than zero.

WN U-16
Zipty Fiber

Original Sheet 522

FACILITIES FOR INTRASTATE ACCESS

11. CARRIER COMMON LINE SERVICE (Cont'd)

11.4 Rate Regulations (Cont'd)

11.4.3 Resold Services (Cont'd)

(D) Rate Regulations Concerning the Resale of MTS/MTS-type Services (Cont'd)

(5) Access Groups and BSAs - Equal Access Offices Only

When all the usage on an access group or BSA originates from and/or terminates to end offices that have been converted to equal access, the premium charges per minute in 11.5, will apply. The minutes billed Carrier Common Line charges will be the adjusted originating intrastate access minutes and the adjusted terminating intrastate access minutes for such access groups or BSAs.

The adjusted originating access minutes will be the originating intrastate access minutes less the reported resold originating MTS/MTS-type service minutes of use in (1)(a), but not less than zero. The adjusted terminating access minutes will be the terminating intrastate access minutes less the reported resold terminating MTS/MTS-type service minutes of use in (1)(b), but not less than zero.

WN U-16
ZiPLY Fiber

Original Sheet 523

FACILITIES FOR INTRASTATE ACCESS

11. CARRIER COMMON LINE SERVICE (Cont'd)

11.4 Rate Regulations (Cont'd)

11.4.3 Resold Services (Cont'd)

(D) Rate Regulations Concerning the Resale of MTS/MTS-type Services (Cont'd)

(6) Access Groups and BSAs - Nonequal Access and Equal Access Offices

When an access group or BSA has usage that originates from and/or terminates to both end offices that have been converted to equal access and end offices that have not been converted, both premium and nonpremium per minute charges in 11.5 will apply respectively. The minutes billed Carrier Common Line charges will be the adjusted originating intrastate access minutes plus the adjusted terminating intrastate access minutes for such access groups or BSAs.

The adjusted originating access minutes will be the originating intrastate access minutes less the reported resold originating MTS/MTS-type service minutes of use in (1)(a), but not less than zero. The adjusted terminating access minutes will be the terminating intrastate access minutes less the reported resold terminating MTS/MTS-type service minutes of use in (1)(b), but not less than zero.

The adjusted originating access minutes and the adjusted terminating access minutes will be apportioned between premium and nonpremium access minutes using end-office specific usage data when available. When usage data is not available, usage ratios, as described in 4.5.2(H)(1) and 4.5.2(H)(6), will be utilized. The premium and nonpremium per minute charges in 11.5 will apply to the respective premium and nonpremium access minutes determined in this manner.

WN U-16
Zipty Fiber

Original Sheet 524

FACILITIES FOR INTRASTATE ACCESS

11. CARRIER COMMON LINE SERVICE (Cont'd)

11.4 Rate Regulations (Cont'd)

11.4.3 Resold Services (Cont'd)

(D) Rate Regulations Concerning the Resale of MTS/MTS-type Services (Cont'd)

(7) When the Adjustment Will Be Applied to Customer Bills

The adjustment, as described in (4), (5) and (6), will be made to the involved customer account no later than either the next bill date, or the one subsequent to that, depending on when the usage report is obtained.

(8) Conversion of Billed Usage to Minutes

When the MTS/MTS-type usage is shown in hours, the number of hours shall be multiplied by 60 to develop the associated MTS/MTS-type minutes of use. If the MTS/MTS-type usage is shown in a unit that does not show hours or minutes, the customer shall provide a factor to convert the shown units to minutes.

(9) Mixed Interstate and Intrastate Usage

The adjustment, as described in (4), (5) and (6) will be made to the involved customer account after making the adjustments to the customer account, as described in 4.5.2(I).

WN U-16
ZiPLY Fiber

Original Sheet 525

FACILITIES FOR INTRASTATE ACCESS

11. CARRIER COMMON LINE SERVICE (Cont'd)

11.5 Rates and Charges

The rates for Carrier Common Line Access Service are:

	<u>Rate per Access Minute</u>
(A) Usage Rate	
Premium, per minute	
Zone 1	
- Terminating	\$.00
- Originating	.00
Zone 2	
- Terminating	.00
- Originating	.00
Zone 3	
- Terminating	.00
- Originating	.00
Nonpremium, per minute	
Zone 1	
- Terminating	.00
- Originating	.00
Zone 2	
- Terminating	.00
- Originating	.00
Zone 3	
- Terminating	.00
- Originating	.00

Issued: July 29, 2020
 Issued by ZiPLY Fiber
 By Jessica Epley, Regulatory & External Affairs Director

Effective: July 31, 2020

WN U-16
Zipty Fiber

Original Sheet 526

FACILITIES FOR INTRASTATE ACCESS

SECTION 12 TABLE OF CONTENTS

12.	<u>EXCEPTIONS TO FIA OFFERINGS</u>	<u>Sheet No.</u>
12.1	Exceptions to FIA Offerings.....	527

WN U-16
Zipty Fiber

Original Sheet 527

FACILITIES FOR INTRASTATE ACCESS

12. EXCEPTIONS TO FIA OFFERINGS

The FIA/Services offered under the provisions of this tariff are subject to availability as described in 2.1.4 and 2.1.2(A)(1). In addition, the following exceptions apply.

12.1 The following FIA/Services are not offered in the operating territory of the Telephone Company:

(Reserved for Future Use)

WN U-16
Zipty Fiber

Original Sheet 528

FACILITIES FOR INTRASTATE ACCESS

SECTION 13 TABLE OF CONTENTS

	<u>Sheet No.</u>
13. <u>OPERATOR SERVICES</u>	
13.1 <u>Directory Assistance Service/Preferred Directory Assistance Service</u>	529
13.1.1 General	529
13.1.2 Description of Service	530
13.1.3 Regulations	531
13.1.4 Rate Regulations	536
13.1.5 Rates and Charges	538
13.2 <u>Operator Transfer Service/Inward Operator Assistance Service</u>	539
13.2.1 General Description	539
13.2.2 Provision of Operator Services.....	542
13.2.3 Rate Regulations	543
13.2.4 Rates and Charges	545

WN U-16
Zipty Fiber

Original Sheet 529

FACILITIES FOR INTRASTATE ACCESS

13. OPERATOR SERVICES

13.1 Directory Assistance Service/Preferred Directory Assistance Service

13.1.1 General

The Telephone Company will provide Directory Assistance Service/Preferred Directory Assistance Service to a customer from Directory Assistance Service locations.

Regulations, rates and charges as follow apply to Directory Assistance/Preferred Directory Assistance and shall not serve as a substitute for customer tariff offerings of services to end users. The provision of such Directory Assistance Service/Preferred Directory Assistance Service by the Telephone Company as described following does not constitute joint undertaking with the customer for the furnishing of any service.

The Telephone Company's undertaking to provide Directory Assistance Service/Preferred Directory Assistance Service is made with intrastate access services.

The regulations, rates and charges contained herein are in addition to the applicable regulations, rates and charges specified in other sections of this tariff and in other tariffs of the Telephone Company which are referenced herein. For Switched Access connections to the Directory Assistance Service location, the rates in Section 4 apply. For Special Access connections to the Directory Assistance Service location, the rates in Section 5 apply.

WN U-16
ZiPLY Fiber

Original Sheet 530

FACILITIES FOR INTRASTATE ACCESS

13. OPERATOR SERVICES (Cont'd)

13.1 Directory Assistance Service/Preferred Directory Assistance Service (Cont'd)

13.1.2 Description of Service

Directory Assistance Service provides access to Directory Assistance Service locations, use of Directory Assistance Service equipment and use of Directory Assistance operators. This function consists of Directory Assistance Service to a customer to enable end users to obtain local telephone numbers maintained by the Telephone Company.

Preferred Directory Assistance provides Directory Assistance to a customer to enable end users to obtain local published telephone numbers in the 206 or 360 NPA (and any future NPAs split out of the 206 or 360 NPA) served by the Telephone Company. The complete directory listing for the 206 or 360 NPA (and any future NPAs split out of the 206 or 360 NPA) includes those customers served by the Telephone Company and those served by other local exchange companies. Preferred Directory Assistance Service incorporates the following characteristics:

- (A) The carrier must presubscribe to the 206 or 360 NPA (or any future NPAs split out of the 206 or 360 NPA).
- (B) Requires a long-term customer commitment over which the per call rate will not change. The customer may select a minimum period of 24 or 36 months.
- (C) Call Branding is provided. Branding content will be mutually agreed upon by the Telephone Company and the customer.

WN U-16
Zipty Fiber

Original Sheet 531

FACILITIES FOR INTRASTATE ACCESS

13. OPERATOR SERVICES (Cont'd)

13.1 Directory Assistance Service/Preferred Directory Assistance Service (Cont'd)

13.1.3 Regulations

(A) Undertaking of the Telephone Company

(1) Discontinuance and Refusal of Directory Assistance Service/Preferred Directory Assistance Service

- (a) If the customer fails to comply with the provisions of this tariff, including any payments to be made by it on the dates or at the times herein specified, and fails within thirty (30) days after written notice via certified mail from the Telephone Company to an officer of the customer's company requesting payment for such noncompliance, the Telephone Company may discontinue the provision of the Directory Assistance Service/Preferred Directory Assistance Service. In case of such discontinuance, all applicable charges shall immediately become due.
- (b) If the customer repeatedly fails to comply with the provisions of this tariff in connection with the provision of Directory Assistance Service/Preferred Directory Assistance Service and fails to correct such course of action after notice as described in (a), the Telephone Company may refuse applications for additional Directory Assistance Service/Preferred Directory Assistance Service.

WN U-16
Zipty Fiber

Original Sheet 532

FACILITIES FOR INTRASTATE ACCESS

13. OPERATOR SERVICES (Cont'd)

13.1 Directory Assistance Service/Preferred Directory Assistance Service (Cont'd)

13.1.3 Regulations (Cont'd)

(B) Obligations of the Customer

(1) Request for Service

- (a) Directory Assistance Service will be offered for a minimum period of six months. Three months prior to the end of the minimum period, or subsequent extension, the customer shall notify the Telephone Company, in writing, if the service is to be discontinued. If no notice is received from the customer, the Telephone Company shall assume that the service is extended for another six months.
- (b) Preferred Directory Assistance Service will be offered for a minimum period of 24 months. The customer also has the option of choosing a 36 month period. Three months prior to the end of the selected period, the customer shall notify the Telephone Company, in writing, if the service is to be discontinued. If no notice is received from the customer, the Telephone Company shall assume that the service is extended for the same initially selected period at the current tariff rate.

WN U-16
Zipty Fiber

Original Sheet 533

FACILITIES FOR INTRASTATE ACCESS

13. OPERATOR SERVICES (Cont'd)

13.1 Directory Assistance Service/Preferred Directory Assistance Service (Cont'd)

13.1.3 Regulations (Cont'd)

(B) Obligations of the Customer (Cont'd)

(1) Request for Service (Cont'd)

- (c) When Directory Assistance Service/Preferred Directory Assistance Service is ordered, the customer shall furnish the Telephone Company, for each state, for each NPA, and for each month in the order period, an estimate of the number of calls (call capacity) to be billed. At a minimum, the customer is required to revise this estimate semi-annually. More frequent revisions of the estimates may be submitted, however, no more than once per month.

(C) Payment Arrangements

(1) Minimum Charges

After service has been provided for a period of 3 months, the customer is subject to minimum monthly charges if in any month within the period ordered the actual call volumes are:

WN U-16
Zipty Fiber

Original Sheet 534

FACILITIES FOR INTRASTATE ACCESS

13. OPERATOR SERVICES (Cont'd)

13.1 Directory Assistance Service/Preferred Directory Assistance Service (Cont'd)

13.1.3 Regulations (Cont'd)

(C) Payment Arrangements Cont'd)

(1) Minimum Charges (Cont'd)

- less than 75% of any one of the previous month's actual calls in the period ordered, or
- less than 75% of the highest forecast in the period ordered, whichever is higher.

Applicability of minimum charges shall be made by comparing the actual call volumes to either the forecasted volumes or the previous months' actual call volumes, whichever is higher.

The minimum monthly charge is computed using the difference between the actual call volume for a month and the calculated minimum (i.e., 75% of the highest forecast or 75% of any previous months' actual), multiplied by the appropriate Directory Assistance Service/Preferred Directory Assistance Service Charge, and then multiplied by 0.5.

WN U-16
ZiPLY Fiber

Original Sheet 535

FACILITIES FOR INTRASTATE ACCESS

13. OPERATOR SERVICES (Cont'd)

13.1 Directory Assistance Service/Preferred Directory Assistance Service (Cont'd)

13.1.3 Regulations (Cont'd)

(C) Payment Arrangements (Cont'd)

(2) Minimum Period Disconnect Charges

- (a) If service is disconnected prior to the end of six months when Directory Assistance Service is ordered, then the customer shall be obligated to pay the Telephone Company nonrecoverable costs, less the net salvage value for any equipment and material provided or used, for the discontinued service. Such charges will be tariffed as they occur.
- (b) If after subscription to Preferred Directory Assistance Service the customer cancels any portion of this service, his rate will revert to the standard Directory Assistance call rate. In addition, the customer will be subject to a cancellation charge equal to the difference between the Preferred Directory Assistance charges and the standard Directory Assistance charges for the period the customer was being charged the Preferred Directory Assistance Service rate.

WN U-16
Zipty Fiber

Original Sheet 536

FACILITIES FOR INTRASTATE ACCESS

13. OPERATOR SERVICES (Cont'd)

13.1 Directory Assistance Service/Preferred Directory Assistance Service (Cont'd)

13.1.4 Rate Regulations

- (A) The Telephone Company Directory Assistance/Preferred Directory Assistance operator, when furnished a name, will provide or attempt to provide the telephone number listed in the Telephone Company Directory Assistance records associated with the name given. The Telephone Company's contact with the end user shall be limited to such contact necessary to process an end user's request for a telephone number.
- (B) A maximum of two requests for telephone numbers will be processed per access to the Directory Assistance/Preferred Directory Assistance operator.
- (C) A telephone number which is not listed in Directory Assistance records will not be available to the end user.
- (D) The Telephone Company reserves the right to determine from which Directory Assistance Service location the service will be provided.
- (E) In the event that a telephone number is not listed in the Directory Assistance records and no number is provided, no credit applies for the call to the Directory Assistance/Preferred Directory Assistance operator.

The customer will receive credit allowances on Directory Assistance Service/Preferred Directory Assistance charges for FIA interruptions as described in 2.4.4.

WN U-16
Zipty Fiber

Original Sheet 537

FACILITIES FOR INTRASTATE ACCESS

13. OPERATOR SERVICES (Cont'd)

13.1 Directory Assistance Service/Preferred Directory Assistance Service (Cont'd)

13.1.4 Rate Regulations (Cont'd)

- (F) The Directory Assistance/Preferred Directory Assistance per call charge in 13.1.5 applies for each call to a Directory Assistance Service location. A chargeable call is one which has been answered by or forwarded to a Directory Assistance/Preferred Directory Assistance operator. The charge applies whether or not the Directory Assistance/Preferred Directory Assistance operator provides the requested telephone number. The number of calls answered or forwarded to Directory Assistance/Preferred Directory Assistance operators will be accumulated by the Telephone Company measuring equipment.
- (G) In the event of a rate increase, the customer rate will be sustained for the agreed upon period (24 months or 36 months) as listed in 13.1.5.

In the event of a rate decrease, the customer may select one of the following options:

- (1) remain at his existing rate until his minimum period expires, or
- (2) exit the agreed upon minimum period and select the new rate. If the customer selects this option, a new minimum period will begin on the date of the rate decrease selection made by the customer.

WN U-16
Zipty Fiber

Original Sheet 538

FACILITIES FOR INTRASTATE ACCESS

13. OPERATOR SERVICES (Cont'd)

13.1 Directory Assistance Service/Preferred Directory Assistance Service (Cont'd)

13.1.5 Rates and Charges

	<u>Rate per Call</u>
Directory Assistance Service	\$.2550
Preferred Directory Assistance Service	
24 Month	.2490
36 Month	.2443

WN U-16
Zipty Fiber

Original Sheet 539

FACILITIES FOR INTRASTATE ACCESS

13. OPERATOR SERVICES (Cont'd)

13.2 Operator Transfer Service/Inward Operator Assistance Service

13.2.1 General Description

Operator Services described in this Section will be provided to access customers as an optional feature with Feature Group C (FGC), Feature Group D (FGD), BSA-C or BSA-D Switched Access Services from designated Operator Services Switching locations in those LATAs where the Telephone Company has the capability to provide such services. Operator Services include Operator Transfer and Inward Operator Assistance functions which enable a customer to provide operator related services to their end users. A customer may order both Operator Transfer and Inward Operator Assistance Services or may order them individually.

(A) Operator Transfer Service

Operator Transfer Service is an originating service that provides call transfer of 0- (the digit 0 with no additional digits) interLATA calls to a participating customer as requested by the calling end user. Operator Transfer Service is provided when an end user dials "0" and is routed to the Telephone Company's operator and requests completion of an interLATA call. Operator Transfer Service provides for the routing of the call from the Telephone Company's Operator Services Switching Location to one customer designated location in the same LATA.

The Telephone Company operator will ask the end user to identify the customer to which they desire to be connected. The operator will then transfer the call to the designated customer.

WN U-16
ZiPLY Fiber

Original Sheet 540

FACILITIES FOR INTRASTATE ACCESS

13. OPERATOR SERVICES (Cont'd)

13.2 Operator Transfer Service/Inward Operator Assistance Service (Cont'd)

13.2.1 General Description (Cont'd)

(A) Operator Transfer Service (Cont'd)

If the end user has no preference, or the identified customer has not subscribed to Operator Transfer Service, the end user will be asked to select from a list of participating customers. The list of participating Operator Transfer Service customers will be updated monthly. The order in which participating customers will appear on the list will be initially determined by use of a random drawing. For each subsequent monthly update following the initial selection, the customer in the first position will be moved to the last position on the list. All other customers will be moved up one position. New Operator Transfer Service customers will be placed at the bottom of the list of participating customers pending the next monthly update.

(B) Inward Operator Assistance Service

Inward Operator Assistance Service provides for operator assistance on inward calls received from a customer's operator. Three Inward Operator Assistance functions are provided as described below. Each call may include any combination of functions for the same telephone number. Only one telephone number per call will be handled by the operator.

WN U-16
Zipty Fiber

Original Sheet 541

FACILITIES FOR INTRASTATE ACCESS

13. OPERATOR SERVICES (Cont'd)

13.2 Operator Transfer Service/Inward Operator Assistance Service (Cont'd)

13.2.1 General Description (Cont'd)

(B) Inward Operator Assistance Service (Cont'd)

- (1) Operator Assistance – The Telephone Company operator will provide the customer's operator with assistance or information regarding service conditions.

WN U-16
Zipty Fiber

Original Sheet 542

FACILITIES FOR INTRASTATE ACCESS

13. OPERATOR SERVICES (Cont'd)

13.2 Operator Transfer Service/Inward Operator Assistance Service (Cont'd)

13.2.2 Provision of Operator Services

- (A) The Telephone Company will provide Operator Transfer Service for calls originating from all end offices within the LATA served by a designated Operator Services Switching Location.

The Telephone Company will provide Inward Operator Assistance Service for calls associated with exchange service lines in end offices served by the Operator Services Switching Location.

A list of end offices served by the Operator Services Switching Location will be provided to the customer upon request.

- (B) Operator Services will be provided over FGC, FGD, BSA-C or BSA-D trunk groups, arranged for either one-way or two-way calling from the Operator Services Switching Location to one customer designated location in the same LATA. Both Operator Transfer and Inward Operator Assistance traffic may be combined on the same trunk group.
- (C) Switched Access used with Operator Services will be provisioned in accordance with the technical specifications and requirements described in Section 4 of this tariff.
- (D) Designated Telephone Company Operator Services Switching Locations are identified in The National Exchange Carrier Association Tariff FCC No. 4. The designated locations will be in those LATAs in which the Telephone Company is able to provide Operator Services.

WN U-16
ZiPLY Fiber

Original Sheet 543

FACILITIES FOR INTRASTATE ACCESS

13. OPERATOR SERVICES (Cont'd)

13.2 Operator Transfer Service/Inward Operator Assistance Service (Cont'd)

13.2.3 Rate Regulations

(A) Operator Services

Where the Telephone Company has measurement capability for Operator Services per call charges, the Telephone Company will bill the actual usage measured on a per call basis. For Operator Transfer Service, FGC, FGD, BSA-C and BSA-D access minutes will also be billed in addition to the per call charge.

When measurement capability is not available, the customer shall furnish a forecast of the number of calls (call capacity) anticipated for each month of the succeeding year by type of call (i.e., Operator Transfer and Inward Operator Assistance calls) and by Operator Services Switching Location at the time the order is placed. For mixed intrastate and interstate services, the customer's estimate shall include the percent of interstate calls. At a minimum, the customer shall revise this forecast annually. More frequent revisions of the forecast may be submitted, however, no more than once per month.

Such estimates shall be used as a basis for billing the Operator Services per call charges until such time as the Telephone Company has actual measurement capability available. The customer shall maintain records supporting such estimates.

WN U-16
Zipty Fiber

Original Sheet 544

FACILITIES FOR INTRASTATE ACCESS

13. OPERATOR SERVICES (Cont'd)

13.2 Operator Transfer Service/Inward Operator Assistance Service (Cont'd)

13.2.3 Rate Regulations (Cont'd)

(A) Operator Services (Cont'd)

(1) Operator Transfer Service Rate

The Operator Transfer Service Rate is assessed per 0 call transferred to a customer. A 0- call is considered transferred when the Telephone Company Operator activates the transfer function sending the call to the designated customer.

Switched Access Charges

FGC, FGD, BSA-C or BSA-D Switched Access usage charges and Carrier Common Line Charges will also apply per minute of use for Operator Transfer Service.

(2) Inward Operator Assistance Service

Inward Operator Assistance Service includes the functions of Operator Assistance. The Inward Operator Assistance rate applies on a per call basis. Each call may include any combination of functions for the same telephone number. A call is considered an Inward Operator Assistance call when the call is received at the Telephone Company's operator position.

FGC, FGD, BSA-C or BSA-D Switched Access usage charges do not apply to Inward Operator Assistance Service.

FACILITIES FOR INTRASTATE ACCESS

13. OPERATOR SERVICES (Cont'd)

13.2 Operator Transfer Service/Inward Operator Assistance Service (Cont'd)

13.2.4 Rates and Charges

(A) <u>Operator Services</u>	<u>Charge</u>
Operator Transfer Service per call transferred	\$.35
Inward Operator Assistance Service per call, per telephone number	.65

WN U-16
Zipty Fiber

Original Sheet 546

FACILITIES FOR INTRASTATE ACCESS

SECTION 14 TABLE OF CONTENTS

	<u>Sheet No.</u>
14. <u>COIN SERVICES</u>	
14.1 <u>General</u>	547
14.2 <u>Service Description</u>	547
14.3 <u>Service Provisioning</u>	549
14.4 <u>Collection and Remittance of Coin Station Monies</u>	549
14.5 <u>Provision of Message Call Detail Concerning Coin Station Monies</u>	550
14.6 <u>Payment of Coin Sent - Paid Monies</u>	551
14.6.1 Bill Period Coin Revenue	551
14.6.2 Total Customer Coin Revenue	551
14.6.3 Recourse Adjustments	552
14.6.4 Payment of Net Customer Coin Revenue	552
14.6.5 Audit Provisions	553

WN U-16
ZiPLY Fiber

Original Sheet 547

FACILITIES FOR INTRASTATE ACCESS

14. COIN SERVICES

14.1 General

This section contains the rules and regulations pertaining to the provision of 1+ Coin Presubscription Service for the handling of 1+ interLATA sent-paid traffic from the Telephone Company's pay telephones.

14.2 Service Description

1+ Coin Presubscription Service provides the routing of 1+ interLATA sent-paid calls from Telephone Company pay telephones to the presubscribed 0+ Interexchange Carrier (customer) directly, to its designated secondary service provider, or to the default carrier, provided said carrier continues to accept such default traffic. The default carrier option will expire when the default carrier ceases to accept such traffic or when the presubscribed 0+ provider can handle such calls or route them to secondary service providers, whichever comes first. The customer has the following options:

- (1) to receive both 0+ and 1+ interLATA calls originated from Telephone Company pay telephones; or,
- (2) to receive the 0+ interLATA calls and select one secondary service provider per LATA to receive the 1+ interLATA sent-paid traffic; or,
- (3) to receive the 0+ interLATA calls and continue to default the 1+ interLATA sent-paid calls until the presubscribed 0+ provider is ready to handle (to receive both 0+ and 1+ interLATA calls or to receive 0+ interLATA calls and select a secondary service provider per LATA for 1+ interLATA calls) such calls.

WN U-16
Zipty Fiber

Original Sheet 548

FACILITIES FOR INTRASTATE ACCESS

14. COIN SERVICES (Cont'd)

14.2 Service Description (Cont'd)

The customer is solely responsible for all 0+ and 1+ interLATA sent-paid calls originating from the Telephone Company pay telephone when it handles 1+ interLATA sent-paid traffic or selects a secondary service provider to handle the 1+ interLATA sent-paid calls.

The Telephone Company must receive written authorization from the customer prior to routing 1+ interLATA sent-paid calls to the selected secondary service provider. If the customer selects a secondary service provider to handle 1+ interLATA sent-paid traffic, any arrangements will be solely between the customer and its selected secondary service provider.

WN U-16
Zipty Fiber

Original Sheet 549

FACILITIES FOR INTRASTATE ACCESS

14. COIN SERVICES (Cont'd)

14.3 Service Provisioning

The Telephone Company will provide 1+ interLATA sent-paid access from equal access end offices to the CDL via direct routed trunks from the end office or via its access tandem.

The Telephone Company will provide, where available, either of two types of call setup signaling from its pay telephones, Tandem Access InterLATA Sent-Paid (TAISP) and Exchange Access Operator Services System (EAOSS) signaling from the access tandem to the CDL. If the equal access end office is equipped with either TAISP or EAOSS functionality, TAISP or EAOSS signaling can be provided via direct trunking from the end office or via the access tandem to the CDL at the customer's option. If the equal access end office is equipped with only Modified Operator Service Signaling (MOSS) functionality, only MOSS will be provided for direct trunking from the end office to the CDL.

Coin control signaling will be either Expanded In-band or Multi-wink as determined by the Telephone Company. In some areas, both types are present and for these locations it will be necessary for the customer to utilize separate trunk groups for the two types.

14.4 Collection and Remittance of Coin Station Monies

When the customer is provided Operator Assistance-Coin or Combined Coin and Noncoin or Operator Assistance-Full Feature Arrangements for sent-paid pay telephone access as described in Section 4, the Telephone Company will collect sent-paid monies from pay telephone stations and will remit monies to the customer as specified in 14.6.4. Upon request from the customer, the Telephone Company will provide message call detail format and bill periods used to determine the monies.

WN U-16
Zipty Fiber

Original Sheet 550

FACILITIES FOR INTRASTATE ACCESS

14. COIN SERVICES (Cont'd)

14.5 Provision of Message Call Detail Concerning Coin Station Monies

Where Operator Assistance-Coin or Combined Coin and Noncoin or Operator Assistance-Full Feature Arrangements for sent-paid pay telephone access is provided to the customer and the customer wishes to receive the monies it is due for the monies collected by the Telephone Company from coin pay telephone stations, the customer shall furnish to the Telephone Company, at a location specified by the Telephone Company, the customer message call detail for the customer sent-paid (coin) pay telephone calls according to the Telephone Company collection schedule. The customer message call detail furnished shall be in a standard format established by the Telephone Company. The Telephone Company will provide the precise details of the required standard format to the customer. If, in the course of Telephone Company business, it is necessary to change the standard format, the Telephone Company will provide notification to the involved customer six months prior to the change.

If no customer message call detail is received from the customer for each bill period established by the Telephone Company, the Telephone Company will assume there were no customer sent-paid (coin) pay telephone calls for the period. In addition the customer shall furnish a schedule of its charges for sent-paid (coin) calls to the Telephone Company at a location and date as specified by the Telephone Company. A change in the customer's schedule of charges shall be furnished to the Telephone Company one day after the charges become effective.

WN U-16
Zipty Fiber

Original Sheet 551

FACILITIES FOR INTRASTATE ACCESS

14. COIN SERVICES (Cont'd)

14.6 Payment of Coin Sent-Paid Monies

The Telephone Company will collect the monies from coin pay telephone stations and will determine the remit amounts due to a customer for sent-paid pay telephone access, as specified in Section 4, as follows:

14.6.1 Bill Period Coin Revenue

The Telephone Company will establish a collection schedule for each coin pay telephone station and will collect the monies from the coin pay stations based on this collection schedule. The monies collected based on this schedule during each bill period established by the Telephone Company will be identified by coin pay telephone station and summed to develop the Bill Period Coin Revenue for each coin record day (i.e., the day a record is prepared and dated to show the amount due the customer).

14.6.2 Total Customer Coin Revenue

The intrastate Total Customer Coin Revenue will be determined by the Telephone Company based on the customer message call detail received from the customer for each bill period and the customer's schedule of charges for sent-paid coin calls. Such Total Customer Coin Revenue will be developed each coin record day.

WN U-16
ZiPLY Fiber

Original Sheet 552

FACILITIES FOR INTRASTATE ACCESS

14. COIN SERVICES (Cont'd)

14.6 Payment of Coin Sent-Paid Monies (Cont'd)

14.6.3 Recourse Adjustments

For each coin record day, the Telephone Company will subtract from the Total Customer Coin Revenue an amount for coin station shortages. Coin station shortages are amounts resulting from unauthorized calling at coin pay telephone stations, use of unauthorized coins (i.e., foreign coins, slugs and improper use of U.S. pennies), unauthorized removal of coins from coin pay telephone stations and coin refunds beyond the Telephone Company's control. Such amount will be rounded to the nearest penny. The shortage factor will be determined by dividing the yearly total coin shortage amount by the yearly total coin revenue amount (i.e., total coin revenue equals the coin revenue due under exchange tariffs, state toll tariffs and interstate toll tariffs). The total coin shortage amount and the total revenue amount will be determined by the Telephone Company through an annual special study.

14.6.4 Payment of Net Customer Coin Revenue

The Telephone Company will determine the Net Customer Coin Revenue for each coin record day by subtracting from the Total Customer Coin Revenue determined, as specified in 14.6.2, the amount for coin station shortages, determined in 14.6.3. On the payment date, which is determined by adding 45 days to the coin record date, the Telephone Company will remit payment to the customer for the Net Customer Coin Revenue.

WN U-16
Zipty Fiber

Original Sheet 553

FACILITIES FOR INTRASTATE ACCESS

14. COIN SERVICES (Cont'd)

14.6 Payment of Coin Sent-Paid Monies (Cont'd)

14.6.5 Audit Provisions

Upon reasonable written notice by the customer to the Telephone Company, the customer shall have the right through its authorized representative to examine and audit all such records and accounts as recognized under accounting practices as containing information bearing upon the determination of the amount payable to the customer. This examination shall occur during normal business hours and at reasonable intervals as determined by the Telephone Company. Adjustments shall be made by the proper party to compensate for any errors or omissions disclosed by such examination or audit. Neither the right to examine and audit nor the right to receive such adjustment shall be affected by any statement to the contrary, appearing on checks or otherwise, unless such statement expressly waiving such right appears in a letter signed by the authorized representative of the party having such right and delivered to the other party.

All information received or reviewed by the customer or its authorized representative is to be considered confidential and is not to be distributed, provided or disclosed in any form to anyone not involved in the audit, nor is such information to be used for any other purpose.

WN U-16
ZiPLY Fiber

Original Sheet 554

FACILITIES FOR INTRASTATE ACCESS

15. RATE ZONE WIRE CENTERS

15.1 General

This section contains a list of each Telephone Company wire center that has been assigned to a rate zone. Rate zones are applicable to the services specified in Section 4. This table lists, by jurisdiction, wire centers assigned to Rate Zones 1, 2, and 3, where applied. Wire Centers noted with an “#” belong to OCN 4423 and those with an “*” belong to OCN 4324.

Wire Center Zone Assignments

<u>Rate Zone</u>	<u>CLLI</u>	<u>Wire Center Name</u>
1	BOTHWAXB	Bothell*
1	EVRTWAXC	Everett Casino*
1	EVRTWAXF	Everett*
1	HLLKWAXX	Halls Lake*
1	JUNTWAXA	Juanita*
1	KRLDWAXX	Kirklandv*
1	MRWYWAXA	Manor Wayv*
1	MYVIWAXX	Marysville*
1	OKHRWAXX	Oak Harbor*
1	RDMDWAXA	Redmond*
1	SMSHWAXA	Sammamish*
1	WNTCWAXX	Wenatchee*
2	ANCRWAXX	Anacortes*
2	ARTNWAXX	Arlington*
2	BRWSWAXA	Brewster*
2	CAMSWAXX	Camas*
2	DVLLWAXX	Duvall*
2	EWNCWAXA	East Wenatchee*
2	FNDLWAXA	Ferndale#
2	KNWCWAXA	Kennewick-Highlands*
2	KNWCWAXB	Kennewick Main*

WN U-16
ZiPLY Fiber

Original Sheet 555

FACILITIES FOR INTRASTATE ACCESS

15. RATE ZONE WIRE CENTERS (Cont'd)

15.1 General (Cont'd)

Wire Center Zone Assignments (Cont'd)

<u>Rate Zone</u>	<u>CLLI</u>	<u>Wire Center Name</u>
2	LKSTWAXA	Lake Stevens*
2	MONRWAXX	Monroe*
2	MSCWIDXX	Moscow*
2	MTVRWAXX	Mount Vernon#
2	PLMNWAXX	Pullman*
2	RCBHWAXX	Richmond Beach*
2	RCLDWAXA	North Richland*
2	RCLDWAXB	Richland*
2	SLLKWAXA	Silver Lake*
2	SNHSWAXX	Snohomish*
3	ACMEWAXA	Acme#
3	ALGRWAXX	Alger#
3	BGLKWAXX	Big Lake#
3	BLANWAXB	Blaine#
3	BNCYWAXX	Benton City*
3	BRBAWAXA	Birch Bay#
3	BRPTWAXX	Bridgeport*
3	BURLWAXX	Burlington#
3	BURLWAXI	Burlington#
3	CHLNWAXX	Chelan*
3	CLVWWAXA	Clearview*
3	CMISWAXA	Camano Island*
3	CNCRWAXX	Concrete#
3	CNWWAXX	Conway#
3	CPVLWAXX	Coupeville#
3	CRLWWAXA	Curlew#
3	CSHRWAXX	Cashmere*
3	CSTRWAXA	Custer#

Issued: July 29, 2020
Issued by ZiPLY Fiber
By Jessica Epley, Regulatory & External Affairs Director

Effective: July 31, 2020

WN U-16
ZiPLY Fiber

Original Page 556

FACILITIES FOR INTRASTATE ACCESS

15. RATE ZONE WIRE CENTERS (Cont'd)

15.1 General (Cont'd)

Wire Center Zone Assignments (Cont'd)

<u>Rate Zone</u>	<u>CLLI</u>	<u>Wire Center Name</u>
3	DMNGWAXA	Deming#
3	DRTNWAXX	Darrington*
3	EDSNWAXX	Edison#
3	ENTTWAXX	Entiat*
3	EVRTWAXA	Everett Primary Center*
3	EVSNWAXX	Everson#
3	FRFDWAXA	Fairfield*
3	FRTNWAXX	Farmington*
3	GERGWAXX	George*
3	GRFDWAXX	Garfield*
3	GRFLWAXX	Granite Falls*
3	GRLDWAXX	Grayland#
3	HMTNWAXA	Lyman#
3	KNWCWAXC	Kennewick-Meadow Springs*
3	LACNWAXX	La Conner#
3	LARLWAXX	Laurel#
3	LATHWAXA	Latah*
3	LKGWWAXA	Lake Goodwin*
3	LKWNWAXA	Lake Wenatchee*
3	LOMSWAXA	Loomis#
3	LVWOWAXX	Leavenworth*
3	LYNDWAXX	Lynden#
3	MLDNWAXA	Malden*
3	MLSNWAXA	Molson-Chesaw#
3	MNFDWAXX	Mansfield*
3	MNSNWAXA	Manson*
3	MPFLWAXA	Maple Falls#
3	MRBLWAXX	Marblemount#

WN U-16
ZiPLY Fiber

Original Sheet 557

FACILITIES FOR INTRASTATE ACCESS

15. RATE ZONE WIRE CENTERS (Cont'd)

15.1 General (Cont'd)

Wire Center Zone Assignments (Cont'd)

<u>Rate Zone</u>	<u>CLLI</u>	<u>Wire Center Name</u>
3	NCBSWAXX	Naches#
3	NILEWAXX	Niles#
3	NWPTWAXX	Newport*
3	OKDLWAXX	Oakesdale*
3	PALSWAXX	Palouse*
3	QNCYWAXX	Quincy*
3	RCFRWAXB	Rockford*
3	ROSLWAXA	Rosalia*
3	RPBLWAXA	Republic#
3	SKYKWAXX	Skykomish*
3	SOLKWAXX	Soap Lake*
3	STPSWAXA	Stevens Pass*
3	STWDWAXX	Stanwood*
3	SULTWAXX	Sultan*
3	SUMSWAXX	Sumas#
3	SWLYWAXX	Sedro Woolley#
3	SWLYWAXA	Sedro Woolley#
3	TEKOWAXX	Tekoa*
3	THTNWAXA	Thornton*
3	TNSKWAXA	Tonasket#
3	WDLDWAXA	Woodland*
3	WRLDWAXA	West Richland*
3	WSHGWAXA	Washougal*
3	WSPTWAXA	Westport#
3	WSRVWAXA	Washougal River*
3	WTVLWAXA	Waterville*