

1
2
3
4
5
6
7
8
9
10
11
12
13
14
15
16
17
18
19
20
21
22
23
24
25
26

BEFORE THE WASHINGTON UTILITIES
AND TRANSPORTATION COMMISSION

In Re Application of
WASTE MANAGEMENT OF
WASHINGTON, INC., d/b/a WM Healthcare
Solutions of Washington

Docket No. TG-120033

DECLARATION OF JEFF DAUB
REGARDING WASTE
MANAGEMENT'S FITNESS

I, Jeff Daub, declare as follows:

1. I am Senior District Manager for Waste Management of Washington, Inc. ("Waste Management") and I make this declaration on personal knowledge.

2. I received a Bachelor of Arts in Social Sciences from Washington State University in 1985. I served as Medical Waste Salesperson and Operations Manager for American Environmental Management from 1988 until 1992. I was the District Manager at BFI Medical Waste from 1992 through 1998 and my responsibilities included all collection operations for Washington, Oregon, Idaho and British Columbia. I was Solid Waste Area Director for Waste Management from 1998 through 2001 and my responsibilities included collection, landfill, and recycling. I was a Salesperson for Stericycle of Washington, Inc. in 2010 and my responsibilities included large quantity generator and hospital sales, customer service, and account maintenance for Washington State with the exception of Spokane County.

1 3. I have been Senior District Manager for Waste Management since 2011. I am
2 responsible for managing and overseeing all Washington operations for Waste Management's
3 United States Department of Agriculture Animal and Plant Health Inspection Service operations
4 and medical waste operations including collections, processing, financial management, and
5 budgeting.

6 **I. RELATIONSHIP WITH CORPORATE AFFILIATES**

7 4. Waste Management is a wholly-owned subsidiary of Waste Management
8 Holdings, Inc. which, itself, is a wholly-owned subsidiary of Waste Management, Inc. Waste
9 Management, Inc. is based in Houston, Texas and is the leading provider of comprehensive
10 waste management services in North America. It is also a leading developer, operator and owner
11 of waste-to-energy and landfill gas-to-energy facilities in the United States. As of December
12 2011, Waste Management, Inc. served nearly 20 million residential, commercial, industrial and
13 municipal customers through a network of 390 collection operations, 287 transfer stations, 271
14 landfill disposal sites, 17 waste-to-energy plants, 107 recycling facilities and 131 beneficial-use
15 landfill gas projects. Waste Management, Inc. has been in business since 1894. A true and
16 correct copy of Waste Management, Inc.'s 2011 Annual Report is attached hereto as Exhibit 1.

17 5. Waste Management's offices are located in Kirkland, Washington. WM
18 Healthcare Solutions of Washington is an operating division of Waste Management which is
19 responsible for Waste Management's regulated biomedical waste ("RMW") services. WM
20 Healthcare Solutions of Washington is not a separate entity. WM Healthcare Solutions of
21 Washington uses a billing and record keeping system which allows for bar code tracking,
22 manifesting, record retention and billing of RMW by weight and/or volume. Waste Management
23 accounting staff in conjunction with accounting staff from national corporate headquarters in
24 Houston, Texas manage the billing of Washington RMW customers. WM Healthcare Solutions
25 of Washington has dedicated, toll-free phone numbers to respond to customer service issues.
26 These phone numbers are answered 24 hours a day, seven days a week.

1 6. Waste Management does not use independent contractors or third parties to
2 collect, transport, or autoclave RMW.

3 **II. PRESENT BIOMEDICAL WASTE SERVICES**

4 7. Presently, there are 13 Waste Management employees in addition to me who are
5 involved with providing Waste Management’s RMW services in Washington. They are:
6 Michael Weinstein (UTC issues), Jeff Altman (Environmental Protection Manager), Jack Floyd
7 (training), Rob Sherman (Director of Operations), Penny Lane (billing), Rod Rosatto (plant
8 operations), Kathy Howard (call center and small quantity generator sales), Glenn Good (driver),
9 Mitchell Billings (driver), Jon Moser (driver), Pedro Ramos (back-up driver and processing plant
10 worker), Sam Billings (processing plant worker), and Carol Dellumo (operations specialist).

11 8. Waste Management supplies its RMW customers with Rehrig Pacific Company
12 reusable, plastic tubs with attached lids in three sizes (17-gallon, 31-gallon, and 43-gallon), and
13 30-gallon cardboard boxes. Waste Management also provides customers with linear, low-
14 density polyethylene red bags with “Regulated Medical Waste” printed in black ink with a six-
15 inch biohazard symbol. The bag sizes are 20” x 13” x 39” x 0015 mil., 45” x 49” x 0015 mil.,
16 and 26” x 22” x 65” x 0015 mil. These bags are certified by their manufacturers as meeting the
17 standards outlined in CFR 49 Part 171.7, ASTM [American Society for Testing and Materials] D
18 1706, and ASTM D 1922. Each container (box or reusable tub) is lined with a red bag prior to
19 the generator depositing medical waste into the container. The generator is required to close the
20 bag with a Department of Transportation-approved knot and close the lid prior to collection by
21 Waste Management. Boxes must be used for “incinerate only” materials and reusable tubs or
22 boxes may be used for materials to be autoclaved.

23 9. Waste Management provides to its employees who handle RMW training in the
24 following subjects: the regulatory definition of RMW, United States Department of
25 Transportation medical waste collection and transportation regulations and guidelines, Waste
26 Management’s requirements for acceptance, tracking and documentation of RMW, Occupational

1 Safety and Health Administration blood borne pathogen regulations, personal protective
2 equipment, spill control and emergency response. Attached hereto as Exhibit 2 are true and
3 correct copies of the materials Waste Management uses to train its employees who handle RMW.
4 All new Waste Management employees who handle RMW receive this training. Employees
5 receive further training at any time that their job functions change. In addition, employees
6 receive training annually regarding blood borne pathogen regulations and they receive training
7 every two years regarding United States Department of Transportation regulations.

8 10. Waste Management's Medical Waste Acceptance Protocol sets forth the types of
9 RMW Waste Management will accept and how the customer must segregate, package, and label
10 the waste for collection by Waste Management. The Protocol is provided to, and must be signed
11 by, each customer. A true and correct copy of the Medical Waste Acceptance Protocol is
12 attached hereto as Exhibit 3.

13 11. Waste Management requires that the customer's name be placed on each
14 container of RMW collected by Waste Management. Waste Management employees affix a bar-
15 code to the outside of each box or container of RMW. Before transporting RMW from customer
16 premises, Waste Management employees visually ensure that the waste is properly labeled,
17 complete Waste Management's tracking documentation, and verify that the waste tracking
18 documentation is accurate. Attached hereto as Exhibit 4 are true and correct copies of Waste
19 Management's Straight Bill of Lading, Straight Bill of Lading & Medical Waste Tracking
20 Document, Medical Waste Tracking Document, and biohazard, sharps, and incineration labels.
21 *See also* Exhibit 2 at WM000318.

22 12. Waste Management scans the barcode on each container at the point of collection.
23 At that time, the generator signs a tracking document and retains a copy of the tracking
24 document. Two other copies of the signed tracking document accompany the waste on the
25 collection truck. Once the waste is received at Waste Management's processing plant, it is
26

1 scanned for radiation, weighed and barcode scanned again. Generator information, the number
2 of containers, and the weight of the waste are uploaded into Waste Management's billing system.

3 13. Waste Management schedules the collection of RMW based on customer need,
4 geography, and day. On-call service is available when customers' containers are not accessible
5 at the time of a scheduled pick-up or when the customer requests on-call service.

6 14. Waste Management marks its vehicles in compliance with United States
7 Department of Transportation regulations including Waste Management's name, its toll-free
8 phone number, the international biohazard symbol, the Department of Transportation-issued
9 identification number, the Seattle-King County Public Health annual inspection sticker, and the
10 UTC G Certificate number. Waste Management vehicles used to transport RMW contain spill
11 kits including the following items for use in the event of a spill: barricade tape, disinfectant,
12 respirator masks, duct tape, nitrile gloves, biohazard stickers, sharps containers, red bags,
13 absorbent pads, coveralls, bleach/water mixture, face shields, heavy rubber gloves, first-aid kits,
14 germicidal antibacterial hand sanitizer, flashlights and batteries. Waste Management requires its
15 employees who handle RMW to wear protective equipment including safety glasses, safety toe
16 and hard soled safety shoes, water resistant safety boots, puncture/cut resistant gloves, face
17 shields, chemically resistant aprons, and respirators as needed. Attached hereto as Exhibit 5 is a
18 true and correct copy of Waste Management's procedures for cleaning up spills of blood borne
19 pathogens. *See also* Exhibit 2 at WM000269-307.

20 15. Waste Management employees daily clean all areas, equipment, and tools which
21 become contaminated or potentially contaminated by untreated RMW. They decontaminate
22 floors and work surfaces at the end of each shift. Reusable containers are decontaminated before
23 being returned to customers. Employees decontaminate the cargo area of trailers and trucks
24 before the vehicle may leave a plant or station.

25 16. Waste Management has a commercial general liability policy with ACE American
26 Insurance Company with a general liability aggregate limit of \$6,000,000 and a limit of

1 \$5,000,000 per occurrence, and a limit of \$1,000,000 for automobile liability, above a self
2 insured retention limit of \$5,000,000. Waste Management also has umbrella coverage from ACE
3 Property & Casualty Insurance Co. with occurrence and aggregate limits of \$15,000,000 and
4 excess auto liability coverage of \$9,000,000. A true and correct copy of Waste Management's
5 Certificate of Liability Insurance is attached hereto as Exhibit 6. This coverage is substantially
6 higher than the coverage obtained by Stericycle of Washington, Inc. ("Stericycle") which
7 provides a general liability aggregate limit of \$2,000,000 and a limit of \$1,000,000 per
8 occurrence, a limit of \$5,000,000 for automobile liability, with umbrella coverage with an
9 occurrence limit of \$5,000,000 and an aggregate limit of \$10,000,000. A true and correct copy
10 of Stericycle's 2012 Certificate of Liability Insurance, obtained through a public records request
11 to the King County Health Department, is attached hereto as Exhibit 7.

12 **III. FACILITIES AND EQUIPMENT USED BY WASTE MANAGEMENT**

13 17. Waste Management transports all RMW to be autoclaved at its Seattle Biomedical
14 Waste Treatment Facility at 149 SW Kenyon Street in Seattle. Autoclaving involves subjecting
15 the waste to steam under pressure in a vessel at intervals. The autoclaved waste is rendered
16 sterile. In 2011, Waste Management processed 317,197.10 pounds of RMW at the Kenyon
17 Street facility. A true and correct copy of Waste Management's 2011 Annual Report to the King
18 County Health Department is attached hereto as Exhibit 8. Attached hereto as Exhibit 9 is a true
19 and correct copy of Waste Management's Biomedical Waste Operating Plan for the Kenyon
20 Street facility which was the subject of review and comment by both the King County Health
21 Department and the Department of Ecology. Following autoclaving, Waste Management
22 transports the treated, sterilized RMW to its Greater Wenatchee Landfill in Wenatchee,
23 Washington or to Waste Management Disposal Service of Oregon, Inc.'s Columbia Ridge
24 Landfill in Arlington, Oregon for final disposal.

25 18. Waste Management transports all pathological and residual chemotherapy waste
26 to be incinerated at the Marion County Solid Waste-to-Energy Facility in Brooks, Oregon.

1 Attached as Exhibit 10 is a true and correct copy of Waste Management's Medical Waste
2 Disposal Agreement with Marion County, Oregon authorizing disposal of RMW at the Marion
3 County Solid Waste-to-Energy Facility in Brooks, Oregon.

4 19. Waste Management incinerates cardboard boxes and box liners after use. After
5 each use, Waste Management sanitizes and reuses its tubs.

6 20. The vehicles Waste Management uses to transport RMW are described in the true
7 and correct copies of the leases for these vehicles which are attached hereto as Exhibit 11.

8 **IV. RELEVANT PERMITS AND REGULATORY ACTIVITY**

9 21. Waste Management provides RMW services pursuant to UTC Certificate No. G-
10 237 a true and correct copy of which is attached hereto as Exhibit 12.

11 22. Waste Management's Biomedical Waste Treatment Facility at 149 SW Kenyon
12 Street in Seattle operates under Solid Waste Facility Permit No. PR0080378 issued by the King
13 County Department of Public Health. The permit is effective from Jan. 1, 2012 until Dec. 31,
14 2012. A true and correct copy of this permit is attached hereto as Exhibit 13. To obtain the 2013
15 permit, Waste Management will send in a check and a written explanation of any changes to its
16 operating plan.

17 23. Waste Management is authorized to collect RMW in the City of Spokane in 2012
18 by the City's Solid Waste Management Department. A true and correct copy of this
19 authorization is attached hereto as Exhibit 14. To obtain the 2013 authorization, Waste
20 Management will fill out the application, send a check for \$1,000, and report in January 2013 the
21 2012 volume of RMW collected in Spokane County.

22 24. Waste Management transports RMW in King County pursuant to Solid Waste
23 Handling Permit for Vehicles No. PR0081085 issued by the King County Department of Public
24 Health. The permit is effective from July 1, 2012 until June 30, 2013. A true and correct copy
25 of this permit is attached hereto as Exhibit 15.

1 25. Waste Management's autoclave processing facility at 8101 First Avenue South in
2 Seattle operates under Wastewater Discharge Authorization No. 785-03 from the King County
3 Wastewater Treatment Division. The authorization is effective from March 26, 2008 through
4 March 25, 2013. A true and correct copy of this authorization is attached hereto as Exhibit 16.

5 26. On September 20, 2011, inspectors of the Washington State Department of
6 Ecology Hazardous Waste and Toxics Reduction Program conducted an inspection of Waste
7 Management's Seattle Biomedical Waste Treatment Facility at 149 SW Kenyon Street in Seattle.
8 The Department of Ecology concluded that Waste Management had failed to properly designate
9 waste liquids and sludges. A true and correct copy of the Department of Ecology's Notice to
10 Comply is attached hereto as Exhibit 17. Waste Management timely submitted to the
11 Department of Ecology on May 11, 2012 a Sampling Plan and Quality Assurance Project Plan as
12 the Department of Ecology requested. After receiving the data from Waste Management, the
13 Department of Ecology authorized Waste Management to resume operations at Kenyon Street
14 without concluding that there had been any improper disposal or treatment of dangerous wastes
15 at the Kenyon Street facility. A true and correct copy of an email exchange between me and
16 David Keeney of the Department of Ecology is attached hereto as Exhibit 18.

17 27. Mike Jeffers, an Environmental Compliance Inspector for Seattle Public Utilities
18 also attended the September 20, 2011 inspection. On September 22, 2011, he advised Waste
19 Management that he had not observed any storm water code violations at the Kenyon Street
20 facility. A true and correct copy of Mr. Jeffers' letter is attached hereto as Exhibit 19.

21 28. On June 26, 2012, Stericycle requested of the UTC copies of all complaints filed
22 with the UTC "regarding Waste Management of Washington, Inc." The UTC subsequently
23 produced to Waste Management all of the public records the UTC had produced in response to
24 Stericycle's request for public records reflecting complaints from 2001 through 2012. There
25 were no consumer complaints to the UTC regarding Waste Management's RMW service.
26

1 29. Other than as described above, Waste Management has not been advised by the
2 UTC or any other regulatory agency of any concerns about, or regulatory violations by, Waste
3 Management related to its RMW services.

4 30. Although it has nothing to do with RMW, in the interest of full disclosure, I am
5 aware that on several occasions, Waste Management's solid waste program has received notices
6 of a regulatory violation. Waste Management has worked promptly and cooperatively to resolve
7 and correct these issues.

8 31. On December 8, 2011, Seattle Public Utilities issued a Notice of Violation and
9 Order for Corrective Action and Penalty to Waste Management related to storm water discharges
10 at Waste Management's Alaska Street facility in Seattle. At the inspection which lead to the
11 Notice of Violation, it was determined that the facility wheel wash was broken which resulted in
12 discharge and trackout of turbid water and industrial process water to the public drainage control
13 system in violation of Waste Management's storm water permit. Waste Management promptly
14 shut down its operations and within thirty minutes had a spill response contractor onsite to clean
15 the impacted catch basins and drainage lines. The wheel was repaired and Waste Management
16 timely paid the \$1,000 penalty to SPU. True and correct copies of the Notice of Violation and
17 the receipt of payment are attached hereto as Exhibit 20.

18 32. On June 28, 2012, the Department of Ecology directed Waste Management's
19 solid waste program to make some changes to its facility in Auburn. Specifically, the
20 Department of Ecology directed Waste Management to make structural changes that would
21 minimize the amount of sediment leaving the site. The various changes are to be implemented
22 on deadlines from September 15, 2012, October 1, 2012, and November 1, 2012. Waste
23 Management has timely completed the changes due by September 15, 2012 and is on track to
24 timely complete the remaining changes. A true and correct copy of the Amended Administrative
25 Order is attached hereto as Exhibit 21.

26 **V. FACILITIES AND EQUIPMENT FOR STATEWIDE SERVICE**

1 33. If statewide service is authorized, Waste Management will require one additional
2 Class A driver to provide RMW services when the RMW revenue increases by approximately
3 30% and, thereafter, each time there is an additional approximately 30% increase in the RMW
4 revenue. Class A drivers are readily available for hire.

5 34. If statewide service is authorized, Waste Management also will require an
6 additional truck to provide RMW services when the RMW revenue increases by approximately
7 30% and, thereafter, each time there is an additional approximately 30% increase in the RMW
8 revenue. Trucks are readily available for purchase or lease.

9 35. If statewide service is authorized, Waste Management will not require additional
10 tub tippers, boilers or autoclaves to provide RMW services. Waste Management's present
11 equipment is operated at 25% of capacity. Waste Management's current daily processing
12 volume for RMW is 3.5 tons on a five-day work week. The autoclave can process 12 tons per
13 24-hour period. Based on plant space and autoclave capacity, I expect that if statewide authority
14 is granted in mid-2013, Waste Management can operate with its existing equipment until at least
15 mid-2015. In addition, Waste Management has two back-up autoclaves available at the Seattle
16 processing plant site which Waste Management can use to process RMW.

17 36. Waste Management is committed to obtaining, as necessary, all necessary
18 employees, vehicles, equipment and facilities to provide statewide RMW service. It has the full
19 financial backing of Waste Management, Inc. to undertake this planned growth.

20 DATED this 1st day of October, 2012, at Kirkland, Washington.

21
22
23 Jeff Daub
24
25
26

CERTIFICATE OF SERVICE

I hereby certify that I have this day served this document upon all parties of record in this proceeding, by the method indicated below, pursuant to WAC 480-07-150.

| | |
|---|--|
| Washington Utilities and Transportation Commission 1300 S. Evergreen Park Dr. SW PO Box 47250 Olympia, WA 98504-7250 360-664-1160 <u>records@utc.wa.gov</u> | <input type="checkbox"/> Via Legal Messenger <input type="checkbox"/> Via Facsimile <input checked="" type="checkbox"/> Via Federal Express <input checked="" type="checkbox"/> Via Email |
| Gregory J. Kopta Administrative Law Judge Washington Utilities and Transportation Commission <u>gkopta@utc.wa.gov</u> | <input type="checkbox"/> Via Legal Messenger <input type="checkbox"/> Via Facsimile <input type="checkbox"/> Via U.S. Mail <input checked="" type="checkbox"/> Via Email |
| Fronda Woods Attorney General's Office of Washington PO Box 40128 Olympia, WA 98504 (360) 664-1225 <u>fwoods@utc.wa.gov</u> <u>bdemarco@utc.wa.gov</u> | <input type="checkbox"/> Via Legal Messenger <input type="checkbox"/> Via Facsimile <input type="checkbox"/> Via U.S. Mail <input checked="" type="checkbox"/> Via Email |
| Stephen B. Johnson Jared Van Kirk Garvey Schubert Barer 1191 Second Avenue, Suite 1800 Seattle, WA 98101 (206) 464-3939 <u>sjohnson@gsblaw.com</u> <u>jvankirk@gsblaw.com</u> <u>vowen@gsblaw.com</u> <u>dbarrientes@gsblaw.com</u> <i>Attorneys for Stericycle of Washington, Inc.</i> | <input type="checkbox"/> Via Legal Messenger <input type="checkbox"/> Via Facsimile <input type="checkbox"/> Via U.S. Mail <input checked="" type="checkbox"/> Via Email |
| James K. Sells 3110 Judson Street Gig Harbor, WA 98335 (360) 981-0168 <u>jamesells@comcast.net</u> <u>cheryls@rsulaw.com</u> <i>Attorney for Protestant WRRRA, Rubatino, Consolidated, Murrey's, and Pullman</i> | <input type="checkbox"/> Via Legal Messenger <input type="checkbox"/> Via Facsimile <input type="checkbox"/> Via U.S. Mail <input checked="" type="checkbox"/> Via Email |

DATED at Seattle, Washington, this 1st day of October, 2012



Lisa Tardiff

Exhibit 1

Driving change in a changing world



WM
WASTE MANAGEMENT®

2011 ANNUAL REPORT

WM000450



“If we were just in the business of picking up trash and taking it to the landfill, our story would be a simple one.

But we take our responsibility for the management of waste far beyond that. We know that customers have different needs, and if we are to be the kind of company that meets those needs, we must prove that we are more responsive, reliable and resourceful than any other company in our industry—and prove it every day.”

These words appeared 10 years ago as the opening statement of the 2001 Waste Management Annual Report. A decade has passed, and much has changed indeed. Today's customers—whether retail, commercial property, public sector, construction, small and medium business, or manufacturing and industrial—are looking for solutions that go far beyond collection and disposal. They want solutions that help reduce the amount of waste generated and put what is discarded to better use. They want solutions that are both environmentally responsible and economically sound—solutions that are innovative, practical, convenient and achievable. Increasingly, customers want solutions that help them meet their own goals for growth, value add and sustainability.

One thing has not changed. Our customers still look to Waste Management to be responsive, reliable and resourceful as we lead the way to discover and deliver new solutions for the management of waste.

Waste Management is driving change to meet the demands of a changing world.

Waste Management, Inc., based in Houston, Texas, is the leading provider of comprehensive waste management services in North America. It is also a leading developer, operator and owner of waste-to-energy and landfill gas-to-energy facilities in the United States. As of December 31, 2011, the company served nearly 20 million residential, commercial, industrial and municipal customers through a network of 390 collection operations, 287 transfer stations, 271 landfill disposal sites, 17 waste-to-energy plants, 107 recycling facilities and 131 beneficial-use landfill gas projects.

To learn more about Waste Management, visit www.wm.com or www.thinkgreen.com.

► To Our Shareholders, Customers, Employees and Communities:



Waste Management's success was built on the foundation of collecting and disposing of trash. Its future will be built on the ability to understand our customers' changing needs and provide targeted, innovative solutions.



David Steiner
President and CEO

► A CHANGING WORLD

Not so long ago, we all viewed waste differently than we do today. It was something to be collected and disposed of. That's all. But the world is changing. People are more aware of the need to conserve natural resources. Conscious of the millions of tons of waste generated across North America each year, more people are stepping up to reduce, reuse and recycle the waste in their homes, businesses and municipalities. People are thinking seriously about the impact of our society's habits on the environment.

As the leading provider of comprehensive waste management services in North America, we continue to provide our customers with the essential, traditional services of collecting and managing waste in a responsible, efficient and safe manner. At the same time, we are thinking about the impact on the environment as well. With changing attitudes comes a great opportunity for our business, as well as a great opportunity to invest in cutting-edge solutions that will benefit the environment now and in the future.

With decades of experience and leadership in the waste industry, Waste Management is uniquely positioned to deliver the comprehensive environmental solutions that will meet the needs of a changing world.

► BUILDING ON STRENGTH

Through the years, our company has worked hard to maintain a foundation of financial and operational strength, and this has served us well through difficult economic times. We drew on this strength in 2011 when the economy once again impacted our business and made for another challenging year.

In 2011, our company performed well despite the economy, and we made significant progress on many important fronts by focusing on yield management, operational efficiency and providing valuable solutions for our customers. Although waste volumes were down in our landfill operations, recycling volumes were up, resulting in a record year for that important and growing business. This demonstrates clearly that customers are modifying their consumption and disposal habits to throw away less and recycle more.

The financial results for the year reflect our company's continuing ability to fund its operations and pursue growth initiatives even in a less than favorable economy.

- Revenues were \$13.4 billion, an increase of 6.9 percent over 2010
- Adjusted earnings per diluted share showed improvement to \$2.14^(a)
- Free cash flow was \$1.2 billion^(b), which reflects the strength of both our operations and our asset base.

In 2011, we paid \$637 million in dividends and completed \$575 million in common stock repurchases, the full amount that was authorized by our board of directors. Through these dividends and share repurchases, we returned \$1.2 billion to shareholders, which equates to 7.5 percent of a \$16 billion market capitalization.

(a) See last page of this 2011 Annual Report for a discussion and reconciliation of this non-GAAP measure.

(b) See page 31 of our Annual Report on Form 10-K (enclosed herein) for a reconciliation and discussion of this non-GAAP measure.

In addition, our board of directors announced its intention to increase the planned quarterly dividend in 2012 by 4.4 percent, from \$1.36 to \$1.42 per share on an annual basis. This increase marks the ninth consecutive year that we have raised our dividend. When the board of directors announced the increase, the dividend yield on our stock placed us in the top 10 percent of dividend-paying companies in Standard & Poor's S&P 500 index.

▶ INVESTING IN THE FUTURE

During the year, we strengthened our business through strategic acquisitions that will provide long-term benefits.

In July of 2011, we acquired Oakleaf Global Holdings, which was North America's leading provider of outsourced waste services. It brings a network of 2,500 preferred haulers and 800 large customers to our business. In 2010, the acquired operations of Oakleaf generated revenues of approximately \$580 million.

The acquisition of Oakleaf substantially expands our geographic service footprint and enhances our ability to provide comprehensive environmental solutions. Sharing Waste Management's strategic focus on sustainability and technological innovation, Oakleaf has a substantial base of national accounts customers and service relationships that provide a solid growth opportunity. The combination of the two companies will provide North American customers with unprecedented access to waste and recycling solutions by pairing the largest network of directly owned hauling, recycling, diversion and disposal assets with the largest third-party collection and service network.

In addition to the Oakleaf acquisition, our investment in other acquisitions included a significant number of recycling operations and was the highest in many years, a testament to our company's strong financial position and commitment to strategic growth.

▶ FOCUSING ON CUSTOMERS

Our knowledge of customers and their waste management needs is the foundation for our approach to driving profitable growth. We work to build collaborative relationships with our customers at all levels and provide valued environmental performance

solutions. We continuously look for ways to advance technologies that reduce waste, increase recycling and reuse, create even safer treatment and disposal options, and develop sources of renewable energy. Through our innovation, we help our customers meet their sustainability goals. And together, we contribute to a more sustainable world.

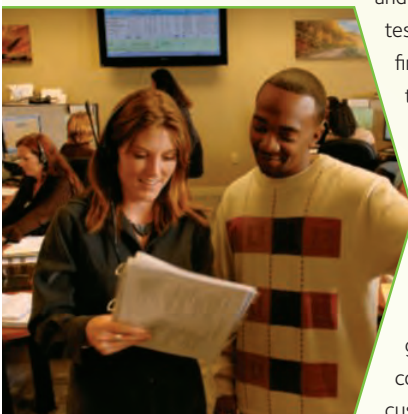

In 2011, we continued to focus on making it easier for customers to do business with us through several major business improvements.

Our employees are using technology to change the way we do business. In 2011, we worked diligently to upgrade the systems behind customer set-up and account management, while at the same time developing the processes and measurements to resolve service issues more quickly. Throughout 2012, this will continue to be a key focus. In Phoenix, a pilot is currently underway that will give our customer service representatives the most modern communications tools, and in Pennsylvania, we're testing a new service platform that will improve the ease of doing business for our customers.

Waste Management is also changing the way its 25 call centers work together, transitioning them from individual operations to a single Customer Experience department made up of more than 1,700 employees. This provides a greater opportunity to upgrade technology, improve performance and provide more environmental products and services to our customers.

To better serve our construction industry customers, we developed and launched a proprietary web application to help contractors, project planners, architects and building owners measure their green performance during construction, renovation and demolition projects. What was traditionally a time-consuming and complex process is made easy by this application that monitors construction and demolition (C&D) recycling, tabulates total diversion rates by waste type, and provides documentation to support LEED® certification. The service is available across the U.S. and Canada and is accessible to our customers 24 hours a day.

We serve thousands of municipalities, and in 2011 we successfully extended 88 percent of our municipal customer contracts that were up for renewal, an increase of 19 percent over the prior year's renewal rate. In addition, by the end of 2011, we had already renewed nearly 25 percent of the contracts coming up for renewal in 2012. We view this as an indication of the growing confidence of these customers in our ability to add value through comprehensive environmental solutions, such as single stream recycling, household hazardous waste removal and the use of natural gas powered trucks.

As these examples demonstrate, we constantly seek to improve the ways we meet the changing needs of our customers and enhance the experience of doing business with Waste Management.

▶ FINDING MORE VALUE IN WASTE

More and more, individuals and businesses are looking for ways to reduce, reuse and recycle so that they can divert trash from landfills. We have responded to the increasing demand for environmentally sound alternatives by investing in technologies that allow us to take the materials we collect—such as yard and food waste, cardboard, glass, plastic, and even everyday trash—



and use them as valuable feedstock to generate energy or create new materials. We are finding many ways to use technology to extract more value from the materials we handle.

Using waste to produce energy. Landfills are the source of a naturally occurring, renewable landfill gas. As the largest landfill gas-to-energy (LFGTE) developer and operator in North America, we are harnessing this energy to power homes, provide fuel for industrial uses, and even fuel vehicles. In 2011, we commissioned six new facilities and three major expansions, bringing the total number of LFGTE facilities to 131 active projects, producing the equivalent of 615 megawatts of power—enough to power over 460,000 homes and offset the consumption of over 2.3 million tons of coal.

In 2011, the U.S. Environmental Protection Agency named Waste Management its Industry Partner of the Year for leadership in developing waste-based renewable energy. We are a pioneer in the field of landfill gas projects, and we developed many of the technologies that are still in use today across the industry.

We also produce electrical power by processing waste into electricity and steam using high temperature combustion technologies. Through our subsidiary Wheelabrator Technologies, we own or operate 17 waste-to-energy plants that use waste as clean-burning, renewable fuel to generate electricity for nearby communities. Altogether, in 2011 Wheelabrator's waste-to-energy projects converted 7.66 million tons of waste into steam and generated up to 4.5 billion kilowatt hours of electricity—enough to power 705,000 homes.

In addition, we have expanded our waste-to-energy business into the U.K. and into China, where four of eight planned plants are now up and running through our joint venture with Shanghai Environmental Group. Together, the eight facilities will process more than 11,750 tons of municipal waste per day, generating more than 210 megawatts of electricity.

Recycling. Waste Management has long been a leader in realizing the value of recycling significant components of the waste stream. 2011 was a record growth year for our recycling business as our

subsidiary WM Recycle America managed over 10 million tons of recyclable commodities through its 100 recycling facilities, nine electronics recycling facilities, two LampTracker® facilities, and extensive third-party processing network.

WM invested close to \$100 million in new processing capacity and upgrading existing facilities in 2011. We also closed on 11 different recycling-related acquisitions. With regulatory changes and increasing customer demand for recycling, we recognize that we must continue to expand our processing footprint and the breadth of products we can process.

Also in 2011, we invested in Recycle Rewards, Inc., whose subsidiary Recyclebank® rewards people for recycling by offering discounts and deals from local and national businesses. The investment brings together Waste Management's large national curbside collection infrastructure with Recyclebank's vast online community and incentive platform, enhancing growth prospects for both companies and motivating more people, communities and schools to recycle.

Organics. In the U.S., about a third of all municipal solid waste is organic, including food, yard and wood waste. This waste stream has been growing by 20 percent per year, and currently 2.5 percent of food waste and 65 percent of yard waste is diverted from landfills. To capture more organic materials, we have made a number of investments to expand our organics recycling solutions.

In 2011, we added the largest composting facility in the eastern U.S. to our network of organics processing facilities through our investment in Peninsula Compost Company. In addition, we developed and opened organics recycling facilities at two Waste Management landfills in Florida, which are processing yard, food and wood waste to create organic compost products.

These investments complement our other organics recycling investments, including Harvest Power, which is developing anaerobic digestion technology to accelerate the decomposition of organic materials to produce renewable energy; and Garick, a leading manufacturer, marketer and distributor of organic lawn and garden products. Recycling organics through composting and other



technologies is part of our commitment to redirect organic waste streams to higher and better uses and help our customers meet their recycling and sustainability goals.

Conversion technologies. We are investing in other new and emerging technologies to convert organic energy into transportation fuels, petrochemicals and chemicals. In 2011, we invested in:

- Agnion Energy, which has a patented technology to convert wood-based organic waste into a high-energy synthetic gas that can be used as fuel for heating or electricity generation
- Agilyx, the first company to economically convert difficult-to-recycle waste plastic into high-quality synthetic crude oil
- Fulcrum BioEnergy, which has an innovative proprietary system to convert municipal solid waste into advanced biofuels
- Genomatica, a leader in creating sustainable chemicals from renewable feedstocks. We are working together in a joint development to use Genomatica's technology to turn the synthetic gas made from municipal solid waste into high-value chemicals.

These complement our previous investments in conversion technology platforms, including Enerkem, InEnTec and Terrabon.

► CLEAN FUEL TECHNOLOGY

With significantly lower emissions, trucks powered with natural gas—either compressed natural gas (CNG) or liquefied natural gas (LNG)—play a key role in helping communities meet their environmental goals. Natural gas trucks deliver nearly zero air particulates and up to 25 percent fewer greenhouse gas emissions. Additionally, the engines run quieter than traditional diesel engines, reducing noise in communities where they operate.

During 2011, we added the 1,400th natural gas powered truck to our fleet, and we are the largest owner and operator of clean-running, heavy-duty recycling and waste trucks in North America. In just one year, our 1,400 natural gas powered trucks

will replace the use of 11 million gallons of petroleum and eliminate over 30,000 metric tons of greenhouse gas emissions.

In addition, we have natural gas fueling stations at 17 of our facilities throughout North America, with more under development. In 2011, we opened new natural gas fueling stations in Camden, New Jersey, and Chicago, Illinois.

During 2011, we made many investments in emerging technologies and operations that move us closer to reaching the sustainability goals we set out to achieve by 2020. Those goals include doubling our renewable energy production to power the equivalent of 2 million homes, expanding our recycling capacity to 20 million tons per year, increasing the fuel and emission efficiency of our fleet, and enhancing wildlife habitats on our lands across North America.

All these goals affirm our belief that a strategy designed to benefit the environment greatly benefits everyone—our business, our shareholders, our employees, our customers, and the communities we serve.

The Waste Management of 10 years ago, a company that primarily picked up and disposed of waste, is different today. And in the next 10 years, we are committed to re-inventing our business again, as we continue to work with our customers, with communities, with partners and entrepreneurs, to drive the change that is needed for our changing world.

Sincerely,

David P. Steiner
President and Chief Executive Officer

Proxy Statement and Form 10-K





1001 Fannin Street, Suite 4000
Houston, Texas 77002

**NOTICE OF ANNUAL MEETING OF STOCKHOLDERS
OF WASTE MANAGEMENT, INC.**

Date and Time:

May 10, 2012 at 11:00 a.m., Central Time

Place:

The Maury Myers Conference Center
Waste Management, Inc.
1021 Main Street
Houston, Texas 77002

Purpose:

- To elect nine directors;
- To ratify the appointment of Ernst & Young LLP as our independent registered public accounting firm for the fiscal year ending December 31, 2012;
- To approve our executive compensation;
- To vote on a proposal to amend our Employee Stock Purchase Plan ("ESPP") to increase the number of shares authorized for issuance under the ESPP;
- To vote on a stockholder proposal relating to a stock retention policy requiring senior executives to retain a significant percentage of stock acquired through equity pay programs until one year following termination of employment, if properly presented at the meeting;
- To vote on a stockholder proposal to amend our By-laws and other governing documents to give stockholders of the lowest percentage of our outstanding Common Stock permitted by state law the power to call special stockholder meetings, if properly presented at the meeting; and
- To conduct other business that is properly raised at the meeting.

Only stockholders of record on March 13, 2012 may vote at the meeting.

Your vote is important. We urge you to promptly vote your shares by telephone, by the Internet or, if this Proxy Statement was mailed to you, by completing, signing, dating and returning your proxy card as soon as possible in the enclosed postage prepaid envelope.

LINDA J. SMITH
Corporate Secretary

March 28, 2012

IMPORTANT NOTICE REGARDING THE AVAILABILITY OF PROXY MATERIALS FOR THE ANNUAL MEETING OF STOCKHOLDERS TO BE HELD ON MAY 10, 2012: This Notice of Annual Meeting and Proxy Statement and the Company's Annual Report on Form 10-K for the year ended December 31, 2011 are available at <http://www.wm.com>.

WM000457

TABLE OF CONTENTS

| | <u>Page</u> |
|---|-------------|
| General Information | 1 |
| Board of Directors | 4 |
| Leadership Structure | 4 |
| Role in Risk Oversight | 4 |
| Independence of Board Members | 5 |
| Meetings and Board Committees | 6 |
| Audit Committee | 6 |
| Audit Committee Report | 8 |
| Management Development and Compensation Committee | 9 |
| Compensation Committee Report | 9 |
| Compensation Committee Interlocks and Insider Participation | 10 |
| Nominating and Governance Committee | 10 |
| Related Party Transactions | 11 |
| Special Committee | 12 |
| Board of Directors Governing Documents | 12 |
| Non-Employee Director Compensation | 12 |
| Election of Directors (Item 1 on the Proxy Card) | 14 |
| Director Nominee and Officer Stock Ownership | 17 |
| Persons Owning More than 5% of Waste Management Common Stock | 18 |
| Section 16(a) Beneficial Ownership Reporting Compliance | 19 |
| Executive Officers | 20 |
| Executive Compensation | 22 |
| Compensation Discussion and Analysis | 22 |
| Executive Compensation Tables | 39 |
| Equity Compensation Plan Table | 52 |
| Ratification of Independent Registered Public Accounting Firm (Item 2 on the Proxy Card) | 54 |
| Proposal on Executive Compensation (Item 3 on the Proxy Card) | 55 |
| Proposal to Amend our ESPP (Item 4 on the Proxy Card) | 57 |
| Stockholder Proposal Regarding Stock Retention Policy for Senior Executives (Item 5 on the Proxy Card) | 60 |
| Stockholder Proposal Regarding Right of Stockholders to Call a Special Stockholder Meeting (Item 6 on the Proxy Card) | 63 |
| Other Matters | 64 |
| Appendix | |
| Employee Stock Purchase Plan | A-1 |

PROXY STATEMENT
ANNUAL MEETING OF STOCKHOLDERS
WASTE MANAGEMENT, INC.
1001 Fannin Street, Suite 4000
Houston, Texas 77002

Our Board of Directors is soliciting your proxy for the 2012 Annual Meeting of Stockholders and at any postponement or adjournment of the meeting. We are furnishing proxy materials to our stockholders primarily via the Internet. On March 28, 2012, we sent an electronic notice of how to access our proxy materials, including our Annual Report, to stockholders that have previously signed up to receive their proxy materials via the Internet. On March 28, 2012, we began mailing a Notice of Internet Availability of Proxy Materials to those stockholders that previously have not signed up for electronic delivery. The Notice contains instructions on how stockholders can access our proxy materials on the website referred to in the Notice or request that a printed set of the proxy materials be sent to them. Internet distribution of our proxy materials is designed to expedite receipt by stockholders, lower the costs of the annual meeting, and conserve natural resources.

| | |
|--|---|
| Record Date | March 13, 2012. |
| Quorum | A majority of shares outstanding on the record date must be present in person or by proxy. |
| Shares Outstanding | There were 462,671,022 shares of Common Stock outstanding and entitled to vote as of March 13, 2012. |
| Voting by Proxy | Internet, phone, or mail. |
| Voting at the Meeting | Stockholders can vote in person during the meeting. Stockholders of record will be on a list held by the inspector of elections. Beneficial holders must obtain a proxy from their brokerage firm, bank, or other stockholder of record and present it to the inspector of elections with their ballot. Voting in person by a stockholder will replace any previous votes submitted by proxy. |
| Changing Your Vote | Stockholders of record may revoke their proxy at any time before we vote it at the meeting by submitting a later-dated proxy via the Internet, by telephone, by mail, by delivering instructions to our Corporate Secretary before the annual meeting revoking the proxy or by voting in person at the annual meeting. If you hold shares through a bank or brokerage firm, you may revoke any prior voting instructions by contacting that firm. |
| Votes Required to Adopt Proposals | Each share of our Common Stock outstanding on the record date is entitled to one vote on each of the nine director nominees and one vote on each other matter. To be elected, a director must receive a majority of the votes cast with respect to that director at the meeting. This means that the number of shares voted "for" a director must exceed 50% of the votes cast with respect to that director. Each of the other proposals requires the favorable vote of a majority of the shares present, either by proxy or in person, and entitled to vote. Additionally, under the rules of the New York Stock Exchange, approval of the amendment to our ESPP requires that votes representing more than 50% of our outstanding shares of Common Stock must be cast on the proposal. |

**Effect of Abstentions and Broker
Non-Votes**

Abstentions will have no effect on the election of directors. For each of the other proposals, abstentions will have the same effect as a vote *against* these matters because they are considered present and entitled to vote.

If your shares are held by a broker, the broker will ask you how you want your shares to be voted. If you give the broker instructions, your shares must be voted as you direct. If you do not give instructions, one of two things can happen depending on the type of proposal. For some proposals, including the ratification of the Company's independent registered public accounting firm, the broker may vote your shares at its discretion. But for other proposals, including the election of directors, the amendment to our ESPP, the advisory vote on executive compensation, and each of the stockholder proposals, the broker cannot vote your shares at all. When that happens, it is called a "broker non-vote." Broker non-votes are counted in determining the presence of a quorum at the meeting, but they are not counted for purposes of calculating the shares present and entitled to vote on particular proposals at the meeting. Broker non-votes also are not considered votes cast for purposes of determining whether votes representing more than 50% of our outstanding shares of Common Stock were cast, as is required for approval of the amendment to the ESPP.

Voting Instructions

You may receive more than one proxy card depending on how you hold your shares. If you hold shares through a broker, your ability to vote by phone or over the Internet depends on your broker's voting process. You should complete and return each proxy or other voting instruction request provided to you.

If you complete and submit your proxy voting instructions, the persons named as proxies will follow your instructions. If you submit your proxy but do not give voting instructions, we will vote your shares as follows:

- *FOR* our director candidates;
- *FOR* the ratification of the independent registered public accounting firm;
- *FOR* approval of our executive compensation;
- *FOR* the proposal to amend our ESPP;
- *AGAINST* the stockholder proposal relating to stock retention by senior executives; and
- *AGAINST* the stockholder proposal relating to the right to call a special stockholder meeting.

If you give us your proxy, any other matters that may properly come before the meeting will be voted at the discretion of the proxy holders.

Attending in Person

Only stockholders, their proxy holders and our invited guests may attend the meeting. If you plan to attend, please bring identification and, if you hold shares in street name, bring your bank or broker statement showing your beneficial ownership of Waste Management stock in order to be admitted to the meeting.

If you are planning to attend our annual meeting and require directions to the meeting, please contact our Corporate Secretary at 713-512-6200.

The only items that will be discussed at this year's annual meeting will be the items set out in the Notice. There will be no presentations.

Stockholder Proposals for the 2013 Annual Meeting

Eligible stockholders who want to have proposals considered for inclusion in the Proxy Statement for our 2013 Annual Meeting should notify our Corporate Secretary at Waste Management, Inc., 1001 Fannin Street, Suite 4000, Houston, Texas 77002. The written proposal must be received at our offices no later than November 29, 2012 and no earlier than October 30, 2012. A stockholder must have been the registered or beneficial owner of (a) at least 1% of our outstanding Common Stock or (b) shares of our Common Stock with a market value of \$2,000 for at least one year before submitting the proposal. Also, the stockholder must continue to own the stock through the date of the 2013 Annual Meeting.

Expenses of Solicitation

We pay the cost of preparing, assembling and mailing this proxy-soliciting material. In addition to the use of the mail, proxies may be solicited personally, by Internet or telephone, or by Waste Management officers and employees without additional compensation. We pay all costs of solicitation, including certain expenses of brokers and nominees who mail proxy materials to their customers or principals. Also, Innisfree M&A Incorporated has been hired to help in the solicitation of proxies for the 2012 Annual Meeting for a fee of approximately \$15,000 plus associated costs and expenses.

Annual Report

A copy of our Annual Report on Form 10-K for the year ended December 31, 2011, which includes our financial statements for fiscal year 2011, is included with this Proxy Statement. The Annual Report on Form 10-K is not incorporated by reference into this Proxy Statement or deemed to be a part of the materials for the solicitation of proxies.

Householding Information

We have adopted a procedure approved by the SEC called "householding." Under this procedure, stockholders of record who have the same address and last name and do not participate in electronic delivery of proxy materials will receive only one copy of the Annual Report and Proxy Statement unless we are notified that one or more of these individuals wishes to receive separate copies. This procedure helps reduce our printing costs and postage fees.

If you wish to receive a separate copy of this Proxy Statement and the Annual Report, please contact: Waste Management, Inc., Corporate Secretary, 1001 Fannin Street, Suite 4000, Houston, Texas 77002, telephone 713-512-6200.

If you do not wish to participate in householding in the future, and prefer to receive separate copies of the proxy materials, please contact: Broadridge Financial Solutions, Attention Householding Department, 51 Mercedes Way, Edgewood, NY 11717, telephone 1-800-542-1061. If you are currently receiving multiple copies of proxy materials and wish to receive only one copy for your household, please contact Broadridge.

BOARD OF DIRECTORS

Our Board of Directors currently has nine members. Each member of our Board is elected annually. Mr. Reum is the Non-Executive Chairman of the Board and presides over all meetings of the Board, including executive sessions that only non-employee directors attend.

Stockholders and interested parties wishing to communicate with the Board or the non-employee directors should address their communications to Mr. W. Robert Reum, Non-Executive Chairman of the Board, c/o Waste Management, Inc., P.O. Box 53569, Houston, Texas 77052-3569.

Leadership Structure

We separated the roles of Chairman of the Board and Chief Executive Officer at our Company in 2004. We believe that having a Non-Executive Chairman of the Board is in the best interests of the Company and stockholders. Over the past several years, the demands made on boards of directors have been increasing. This is in large part due to increased regulation under federal securities laws, national stock exchange rules and other federal and state regulatory changes. More recently, on-going market challenges and economic conditions have increased the demands made on boards of directors. The Non-Executive Chairman's responsibilities include leading full Board meetings and executive sessions, as well as ensuring best practices and managing the Board function. The Board named Mr. Reum Chairman of the Board effective January 1, 2012, due to his tenure with and experience and understanding of the Company, as well as his experience on public company boards of directors.

The separation of the positions allows Mr. Reum to focus on management of Board matters and allows our Chief Executive Officer to focus his attention on managing our business. Additionally, we believe the separation of those roles ensures the independence of the Board in its oversight role of critiquing and assessing the Chief Executive Officer and management generally.

Role in Risk Oversight

Our executive officers have the primary responsibility for risk management within our Company. Our Board of Directors oversees risk management to ensure that the processes designed and implemented by our executives are adapted to and integrated with the Company's strategy and are functioning as directed. The primary means by which the Board oversees our risk management structures and policies is through its regular communications with management and our enterprise risk management process. The Company believes that its leadership structure is conducive to comprehensive risk management practices, and that the Board's involvement is appropriate to ensure effective oversight.

The Company initiated an enterprise risk management process several years ago, which is coordinated by the Company's Internal Audit department, under the supervision of the Company's principal financial officer. This process initially involved the identification of the Company's programs and processes related to risk management, and the individuals responsible for them. Included was a risk assessment survey completed by senior personnel requesting information regarding perceived risks to the Company, with follow-up interviews with members of senior management to review any gaps between their and their direct reports' responses. The information gathered was tailored to coordinate with the Company's strategic planning process such that the risks could be categorized in a manner that identified the specific Company strategies that may be jeopardized and plans could be developed to address the risks to those strategies. The Company then conducted an open-ended survey aligned with the objectives of the Company's strategic goals with several individuals with broad risk management and/or risk oversight responsibilities. Included in the survey was the identification of the top concerns, assessment of their risk impact and probability, and identification of the responsible risk owner. Finally, a condensed survey of top risks was completed by approximately 200 senior personnel to validate the risks and the risk rankings.

In 2011, additional steps were taken to enhance the enterprise risk management program and process. In mid year, Board members were polled to collect their thoughts on significant risks facing the Company and how the reporting format should be revised to improve management's communication of enterprise risks to the Board. An

open-ended survey was also sent to over 100 senior personnel across the Company requesting their input relating to risks, including assessment of likelihood and severity, and known controls and metrics to monitor the risks. In addition, external stakeholders were interviewed to gather their views on risks that they perceived could have a significant impact on the Company or the industry. Finally, responsible risk owners were asked to perform in-depth analyses of their assigned risks to ensure the accuracy of their previous assessment and to ensure that appropriate mitigating and/or monitoring activities are in place.

The Board of Directors and its committees meet in person approximately six times a year, including one meeting that is dedicated specifically to strategic planning, and regular updates are given to the Board of Directors on all Company risks. At each of these meetings, our President and Chief Executive Officer; principal financial officer; and General Counsel are asked to report to the Board and, when appropriate, specific committees. Additionally, other members of management and employees are requested to attend meetings and present information, including those responsible for our Internal Audit, Environmental Audit, Business Ethics and Compliance, Human Resources, Government Affairs, Risk Management, Safety and Accounting functions. One of the purposes of these presentations is to provide direct communication between members of the Board and members of management; the presentations provide members of the Board with the information necessary to understand the risk profile of the Company, including information regarding the specific risk environment, exposures affecting the Company's operations and the Company's plans to address such risks. In addition to information regarding general updates to the Company's operational and financial condition, management reports to the Board on a number of specific issues meant to inform the Board about the Company's outlook and forecasts, and any impediments to meeting those or its pre-defined strategies generally. These direct communications between management and the Board of Directors allow the Board to assess management's evaluation and management of the risks of the Company.

Management is encouraged to communicate with the Board of Directors with respect to extraordinary risk issues or developments that may require more immediate attention between regularly scheduled Board meetings. Mr. Reum, as Non-Executive Chairman, facilitates communications with the Board of Directors as a whole and is integral in initiating the frank, candid discussions among the independent Board members necessary to ensure management is adequately evaluating and managing the Company's risks. These intra-Board communications are essential in its oversight function. Additionally, all members of the Board are invited to attend all committee meetings, regardless of whether the individual sits on the specific committee, and committee chairs report to the full Board. These practices ensure that all issues affecting the Company are considered in relation to each other and by doing so, risks that affect one aspect of our Company can be taken into consideration when considering other risks.

In addition, the Audit Committee is responsible for ensuring that an effective risk assessment process is in place, and quarterly reports are made to the Audit Committee on all financial and compliance risks in accordance with New York Stock Exchange requirements.

Independence of Board Members

The Board of Directors has determined that each of the following eight non-employee director candidates is independent in accordance with the New York Stock Exchange listing standards:

Bradbury H. Anderson
Pastora San Juan Cafferty
Frank M. Clark, Jr.
Patrick W. Gross
John C. Pope
W. Robert Reum
Steven G. Rothmeier
Thomas H. Weidemeyer

Mr. Steiner is an employee of the Company and, as such, is not considered an "independent" director.

To assist the Board in determining independence, the Board of Directors adopted categorical standards of director independence, which meet or exceed the requirements of the New York Stock Exchange. These standards specify certain relationships that are prohibited in order for the non-employee director to be deemed independent. In addition to these categorical standards, our Board makes a subjective determination of independence considering relevant facts and circumstances. The Board reviewed all commercial and non-profit affiliations of each non-employee director and the dollar amount of all transactions between the Company and each entity with which a non-employee director is affiliated to determine independence. These transactions included the Company, through its subsidiaries, providing waste management services in the ordinary course of business and the Company's subsidiaries purchasing goods and services in the ordinary course of business. The categorical standards our Board uses in determining independence are included in our Corporate Governance Guidelines, which can be found on our website. The Board has determined that each non-employee director candidate meets these categorical standards and that there are no other relationships that would affect independence.

Meetings and Board Committees

Last year the Board held eight meetings and each committee of the Board met independently as set forth below. Each director attended at least 75% of the meetings of the Board and the committees on which he served. In addition, all directors attended the 2011 Annual Meeting of Stockholders. Although we do not have a formal policy regarding director attendance at annual meetings, it has been longstanding practice that all directors attend unless there are unavoidable schedule conflicts or unforeseen circumstances.

The Board appoints committees to help carry out its duties. In particular, Board committees work on key issues in greater detail than would be possible at full Board meetings. Each committee reviews the results of its meetings with the full Board, and all members of the Board are invited to attend all committee meetings. The Board has three separate standing committees: the Audit Committee; the Management Development and Compensation Committee (the "MD&C Committee"); and the Nominating and Governance Committee. Additionally, the Board has the power to appoint additional committees, as it deems necessary. In 2006, the Board appointed a Special Committee, as described below.

The Audit Committee

Mr. Gross has been the Chairman of our Audit Committee since May 2010. The other members of our Audit Committee are Messrs. Clark, Reum, Rothmeier and Weidemeyer. Each member of our Audit Committee satisfies the additional New York Stock Exchange independence standards for audit committees set forth in Section 10A of the Securities Exchange Act of 1934, as amended. Our Audit Committee held nine meetings in 2011.

SEC rules require that we have at least one financial expert on our Audit Committee. Our Board of Directors has determined that Mr. Gross and Mr. Rothmeier are Audit Committee financial experts for purposes of the SEC's rules based on a thorough review of their education and financial and public company experience.

Mr. Gross was a founder of American Management Systems where he was principal executive officer for over 30 years. He has served as Chairman of The Lovell Group, a private investment and advisory firm, since 2001. Mr. Gross holds an MBA from the Stanford University Graduate School of Business, a master's degree in engineering science from the University of Michigan and a bachelor's degree in engineering science from Rensselaer Polytechnic Institute. Mr. Gross serves on four public company audit committees in addition to ours. The Board reviewed the time Mr. Gross spends on each company's audit committee and the time he spends on other companies' interests and determined that such service and time does not impair his ability to serve on our Audit Committee.

Mr. Rothmeier served in various leadership positions in the airline industry for approximately 16 years, including the positions of Chairman, CEO and CFO of Northwest Airlines. He founded Great Northern Capital, a private investment management, consulting and merchant banking firm, in 1993, where he continues to serve as Chairman and CEO. Mr. Rothmeier has a master's degree in finance from the University of Chicago Graduate School of Business and a bachelor's degree in business administration from the University of Notre Dame.

With the exception of Mr. Gross, none of the other Audit Committee members currently serve on the audit committees of other public companies.

The Audit Committee's duties are set forth in a written charter that was approved by the Board of Directors. A copy of the charter can be found on our website. The Audit Committee generally is responsible for overseeing all matters relating to our financial statements and reporting, internal audit function and independent auditors. As part of its function, the Audit Committee reports the results of all of its reviews to the full Board. In fulfilling its duties, the Audit Committee, has the following responsibilities:

Administrative Responsibilities

- Report to the Board, at least annually, all public company audit committee memberships by members of the Audit Committee;
- Perform an annual review of its performance relative to its charter and report the results of its evaluation to the full Board; and
- Adopt an orientation program for new Audit Committee members.

Independent Auditor

- Engage an independent auditor, determine the auditor's compensation and replace the auditor if necessary;
- Review the independence of the independent auditor and establish our policies for hiring current or former employees of the independent auditor;
- Evaluate the lead partner of our independent audit team and review a report, at least annually, describing the independent auditor's internal control procedures; and
- Pre-approve all services, including non-audit engagements, provided by the independent auditor.

Internal Audit

- Review the plans, staffing, reports and activities of the internal auditors; and
- Review and establish procedures for receiving, retaining and handling complaints, including anonymous complaints by our employees, regarding accounting, internal controls and auditing matters.

Financial Statements

- Review financial statements and Forms 10-K and 10-Q with management and the independent auditor;
- Review all earnings press releases and discuss with management the type of earnings guidance that we provide to analysts and rating agencies;
- Discuss with the independent auditor any material changes to our accounting principles and matters required to be communicated by Public Company Accounting Oversight Board (United States) Audit Standard AU Section 380 *Communication with Audit Committees*;
- Review our financial reporting, accounting and auditing practices with management, the independent auditor and our internal auditors;
- Review management's and the independent auditor's assessment of the adequacy and effectiveness of internal controls over financial reporting; and
- Review executive officer certifications related to our reports and filings.

Audit Committee Report

The role of the Audit Committee is, among other things, to oversee the Company's financial reporting process on behalf of the Board of Directors, to recommend to the Board whether the Company's financial statements should be included in the Company's Annual Report on Form 10-K and to select the independent auditor for ratification by stockholders. Company management is responsible for the Company's financial statements as well as for its financial reporting process, accounting principles and internal controls. The Company's independent auditors are responsible for performing an audit of the Company's financial statements and expressing an opinion as to the conformity of such financial statements with accounting principles generally accepted in the United States.

The Audit Committee has reviewed and discussed the Company's audited financial statements as of and for the year ended December 31, 2011 with management and the independent registered public accounting firm, and has taken the following steps in making its recommendation that the Company's financial statements be included in its annual report:

- First, the Audit Committee discussed with Ernst & Young, the Company's independent registered public accounting firm for fiscal year 2011, those matters required to be discussed by Public Company Accounting Oversight Board (United States) Audit Standard AU Section 380 *Communication with Audit Committees*, including information regarding the scope and results of the audit. These communications and discussions are intended to assist the Audit Committee in overseeing the financial reporting and disclosure process.
- Second, the Audit Committee discussed with Ernst & Young its independence and received from Ernst & Young a letter concerning independence as required under applicable independence standards for auditors of public companies. This discussion and disclosure helped the Audit Committee in evaluating such independence. The Audit Committee also considered whether the provision of other non-audit services to the Company is compatible with the auditor's independence.
- Third, the Audit Committee met periodically with members of management, the internal auditors and Ernst & Young to review and discuss internal controls over financial reporting. Further, the Audit Committee reviewed and discussed management's report on internal control over financial reporting as of December 31, 2011, as well as Ernst & Young's report regarding the effectiveness of internal control over financial reporting.
- Finally, the Audit Committee reviewed and discussed, with the Company's management and Ernst & Young, the Company's audited consolidated balance sheet as of December 31, 2011, and consolidated statements of income, cash flows and equity for the fiscal year ended December 31, 2011, including the quality, not just the acceptability, of the accounting principles, the reasonableness of significant judgments and the clarity of the disclosure.

The Committee has also discussed with the Company's internal auditors and independent registered public accounting firm the overall scope and plans of their respective audits. The Committee meets periodically with both the internal auditors and independent registered public accounting firm, with and without management present, to discuss the results of their examinations and their evaluations of the Company's internal controls over financial reporting.

The members of the Audit Committee are not engaged in the accounting or auditing profession and, consequently, are not experts in matters involving auditing or accounting. In the performance of their oversight function, the members of the Audit Committee necessarily relied upon the information, opinions, reports and statements presented to them by Company management and by the independent registered public accounting firm.

Based on the reviews and discussions explained above (and without other independent verification), the Audit Committee recommended to the Board (and the Board approved) that the Company's financial statements be included in its annual report for its fiscal year ended December 31, 2011. The Committee has also approved

the selection of Ernst & Young as the Company's independent registered public accounting firm for fiscal year 2012.

The Audit Committee of the Board of Directors

Patrick W. Gross, *Chairman*
Frank M. Clark, Jr.
W. Robert Reum
Steven G. Rothmeier
Thomas H. Weidemeyer

The Management Development and Compensation Committee

Mr. Clark has served as the Chairman of our MD&C Committee since May 2011. The other members of the Committee are Ms. Cafferty and Messrs. Anderson, Pope, Reum and Rothmeier. Each member of our MD&C Committee is independent in accordance with the rules and regulations of the New York Stock Exchange. The MD&C Committee met six times in 2011.

Our MD&C Committee is responsible for overseeing all of our executive and senior management compensation, as well as developing the Company's compensation philosophy generally. The MD&C Committee's written charter, which was approved by the Board of Directors, can be found on our website. In fulfilling its duties, the MD&C Committee has the following responsibilities:

- Review and establish policies governing the compensation and benefits of all of our executives;
- Approve the compensation of our senior management and set the bonus plan goals for those individuals;
- Conduct an annual evaluation of our Chief Executive Officer by all independent directors to set his compensation;
- Oversee the administration of all of our equity-based incentive plans;
- Review the results of the stockholder advisory vote on executive compensation and consider any implications of such voting results on the Company's compensation programs;
- Recommend to the full Board new Company compensation and benefit plans or changes to our existing plans; and
- Perform an annual review of its performance relative to its charter and report the results of its evaluation to the full Board.

In overseeing compensation matters, the MD&C Committee may delegate authority for day-to-day administration and interpretation of the Company's plans, including selection of participants, determination of award levels within plan parameters, and approval of award documents, to Company employees. However, the MD&C Committee may not delegate any authority under those plans for matters affecting the compensation and benefits of the executive officers.

For additional information on the MD&C Committee, see the Compensation Discussion and Analysis on page 22.

Compensation Committee Report

The MD&C Committee has reviewed and discussed the Compensation Discussion and Analysis, beginning on page 22, with management. Based on the review and discussions, the MD&C Committee recommended to the

Board of Directors that the Compensation Discussion and Analysis be included in the Company's Proxy Statement.

The Management Development and Compensation
Committee of the Board of Directors

Frank M. Clark, Jr., *Chairman*
Bradbury H. Anderson
Pastora San Juan Cafferty
John C. Pope
W. Robert Reum
Steven G. Rothmeier

Compensation Committee Interlocks and Insider Participation

During 2011, Ms. Cafferty and Messrs. Anderson, Clark, Pope, Reum, Rothmeier and Weidemeyer served on the MD&C Committee. No member of the MD&C Committee was an officer or employee of Waste Management during 2011; no member of the MD&C Committee is a former officer of the Company; and during 2011, none of our executive officers served as a member of a board of directors or compensation committee of any entity that has one or more executive officers who serve on our board of directors or MD&C Committee.

The Nominating and Governance Committee

Mr. Weidemeyer has served as the Chairman of our Nominating and Governance Committee since May 2011. The other members of the Committee include Ms. Cafferty and Messrs. Anderson, Gross, Pope and Reum. Each member of our Nominating and Governance Committee is independent in accordance with the rules and regulations of the New York Stock Exchange. In 2011, the Nominating and Governance Committee met seven times.

The Nominating and Governance Committee has a written charter that has been approved by the Board of Directors and can be found on our website. It is the duty of the Nominating and Governance Committee to oversee matters regarding corporate governance. In fulfilling its duties, the Nominating and Governance Committee has the following responsibilities:

- Review and recommend the composition of our Board, including the nature and duties of each of our committees, in accordance with our Corporate Governance Guidelines;
- Evaluate and recommend to the Board the compensation paid to our non-employee directors;
- Evaluate the charters of each of the committees and recommend directors to serve as committee chairs;
- Review individual director's performance in consultation with the Chairman of the Board and review the overall effectiveness of the Board;
- Recommend retirement policies for the Board, the terms for directors and the proper ratio of employee directors to outside directors;
- Perform an annual review of its performance relative to its charter and report the results of its evaluation to the full Board;
- Review stockholder proposals received for inclusion in the Company's proxy statement and recommend action to be taken with regard to the proposals to the Board; and
- Identify and recommend to the Board candidates to fill director vacancies.

Potential director candidates are identified through various methods; the Nominating and Governance Committee welcomes suggestions from directors, members of management, and stockholders. From time to time, the Nominating and Governance Committee uses outside consultants to assist it with identifying potential director candidates.

For all potential candidates, the Nominating and Governance Committee considers all factors it deems relevant, such as a candidate's personal and professional integrity and sound judgment, business and professional skills and experience, independence, possible conflicts of interest, diversity, and the potential for effectiveness, in conjunction with the other directors, to serve the long-term interests of the stockholders. While there is no formal policy with regard to consideration of diversity in identifying director nominees, the Committee considers diversity in business experience, professional expertise, gender and ethnic background, along with various other factors when evaluating director nominees. The Committee uses a matrix of functional and industry experiences to develop criteria to select candidates. Before being nominated by the Nominating and Governance Committee, director candidates are interviewed by the Chief Executive Officer and a minimum of two members of the Nominating and Governance Committee, including the Non-Executive Chairman of the Board. Additional interviews may include other members of the Board, representatives from senior levels of management and an outside consultant.

The Nominating and Governance Committee will consider all potential nominees on their merits without regard to the source of recommendation. The Nominating and Governance Committee believes that the nominating process will and should continue to involve significant subjective judgments. To suggest a nominee, you should submit your candidate's name, together with biographical information and his or her written consent to nomination to the Chairman of the Nominating and Governance Committee, Waste Management, Inc., 1001 Fannin Street, Suite 4000, Houston, Texas 77002, between October 30, 2012 and November 29, 2012.

Related Party Transactions

The Board of Directors has adopted a written Related Party Transactions Policy for the review and approval or ratification of related party transactions. Our policy generally defines related party transactions as current or proposed transactions in excess of \$120,000 in which (i) the Company is a participant and (ii) any director, executive officer or immediate family member of any director or executive officer has a direct or indirect material interest. In addition, the policy sets forth certain transactions that will not be considered related party transactions, including (i) executive officer compensation and benefit arrangements; (ii) director compensation arrangements; (iii) business travel and expenses, advances and reimbursements in the ordinary course of business; (iv) indemnification payments and advancement of expenses, and payments under directors' and officers' indemnification insurance policies; (v) any transaction between the Company and any entity in which a related party has a relationship solely as a director, a less than 5% equity holder, or an employee (other than an executive officer); and (vi) purchases of Company debt securities, provided that the related party has a passive ownership of no more than 2% of the principal amount of any outstanding series. The Nominating and Governance Committee is responsible for overseeing the policy.

All executive officers and directors are required to notify the General Counsel or the Corporate Secretary as soon as practicable of any proposed transaction that they or their family members are considering entering into that involves the Company. The General Counsel will determine whether potential transactions or relationships constitute related party transactions that must be referred to the Nominating and Governance Committee.

The Nominating and Governance Committee will review a detailed description of the transaction, including:

- the terms of the transaction;
- the business purpose of the transaction;
- the benefits to the Company and to the relevant related party; and
- whether the transaction would require a waiver of the Company's Code of Conduct.

In determining whether to approve a related party transaction, the Nominating and Governance Committee will consider, among other things, whether:

- the terms of the related party transaction are fair to the Company and such terms would be reasonable in an arms-length transaction;
- there are business reasons for the Company to enter into the related party transaction;

- the related party transaction would impair the independence of any non-employee director;
- the related party transaction would present an improper conflict of interest for any director or executive officer of the Company; and
- the related party transaction is material to the Company or the individual.

Any member of the Nominating and Governance Committee who has an interest in a transaction presented for consideration will abstain from voting on the related party transaction.

The Nominating and Governance Committee's consideration of related party transactions and its determination of whether to approve such a transaction are reflected in the minutes of the Nominating and Governance Committee's meetings. The Company is not aware of any transactions that are required to be disclosed.

Special Committee

The Board of Directors appointed a Special Committee in November 2006 to make determinations regarding the Company's obligation to provide indemnification when and as may be necessary. The Special Committee consists of Mr. Gross and Mr. Weidemeyer. The Special Committee held two meetings in 2011.

Board of Directors Governing Documents

Stockholders may obtain copies of our Corporate Governance Guidelines, the Charters of the Audit Committee, the MD&C Committee, and the Nominating and Governance Committee, and our Code of Conduct free of charge by contacting the Corporate Secretary, c/o Waste Management, Inc., 1001 Fannin Street, Suite 4000, Houston, Texas 77002 or by accessing the "Corporate Governance" section of the "Investor Relations" page on our website at <http://www.wm.com>.

Non-Employee Director Compensation

Our non-employee director compensation program consists of equity awards and cash consideration. Compensation for directors is recommended annually by the Nominating and Governance Committee with the assistance of an independent third-party consultant, and set by action of the Board of Directors. The Board's goal in designing directors' compensation is to provide a competitive package that will enable the Company to attract and retain highly skilled individuals with relevant experience. The compensation also is designed to reward the time and talent required to serve on the board of a company of our size and complexity. The Board seeks to provide sufficient flexibility in the form of compensation delivered to meet the needs of different individuals while ensuring that a substantial portion of directors' compensation is linked to the long-term success of the Company.

Equity Compensation

Non-employee directors receive an annual grant of shares of Common Stock under the Company's 2009 Stock Incentive Plan. There are no restrictions on the shares; however, non-employee directors are subject to ownership guidelines that establish a minimum ownership standard and require that all net shares received in connection with a stock award, after selling shares to pay all applicable taxes, be held during their tenure as a director and for one year following termination of Board service. The grant of shares is made in two equal installments and the number of shares issued is based on the market value of our Common Stock on the dates of grant, which are January 15 and July 15 of each year. In 2011, the total annual equity grant to non-employee directors was valued at \$130,000 and each director received a grant valued at \$65,000 on each of January 15, 2011 and July 15, 2011. In addition to the annual grant, Mr. Pope received a grant of shares valued at \$100,000 for his service as Non-Executive Chairman of the Board in 2011, which was also awarded in two equal installments on January 15 and July 15. The grant date fair value of the awards is equal to the number of shares issued times the market value of our Common Stock on that date; there are no assumptions used in the valuation of shares.

Cash Compensation

All non-employee directors receive an annual cash retainer for Board service and additional cash retainers for serving as a committee chair. Directors do not receive meeting fees in addition to the retainers. The cash retainers are payable in two equal installments in January and July of each year. The payments of the retainers for each six-month period are not subject to refund. The table below sets forth the cash retainers for 2011:

| | |
|-------------------------------|--|
| Annual Retainer | \$105,000 |
| Annual Chair Retainers | \$100,000 for Non-Executive Chairman |
| | \$25,000 for Audit Committee Chair |
| | \$20,000 for MD&C Committee Chair |
| | \$15,000 for Nominating and Governance Committee Chair |
| Other Annual Retainers | \$10,000 for Special Committee |

The table below shows the aggregate cash paid, and stock awards issued, to the non-employee directors in 2011 in accordance with the descriptions set forth above:

| <u>Name</u> | <u>Fees Earned or Paid in Cash (\$)</u> | <u>Stock Awards \$(1)</u> | <u>Total (\$)</u> |
|-------------------------------------|---|-----------------------------------|-----------------------|
| Bradbury H. Anderson | 45,000 | 56,000 | 101,000 |
| Pastora San Juan Cafferty | 112,500 | 130,000 | 242,500 |
| Frank M. Clark, Jr. | 115,000 | 130,000 | 245,000 |
| Patrick W. Gross | 135,000 | 130,000 | 265,000 |
| John C. Pope. | 205,000 | 230,000 | 435,000 |
| W. Robert Reum | 115,000 | 130,000 | 245,000 |
| Steven G. Rothmeier | 105,000 | 130,000 | 235,000 |
| Thomas H. Weidemeyer | 117,500 | 130,000 | 247,500 |

(1) Amounts in this column represent the grant date fair value of stock awards granted in 2011, in accordance with Financial Accounting Standards Board Accounting Standards Codification Topic 718.

ELECTION OF DIRECTORS
(Item 1 on the Proxy Card)

The first proposal on the agenda is the election of nine directors to serve until the 2013 Annual Meeting of Stockholders or until their respective successors have been duly elected and qualified. The Board has nominated the nine director candidates named below, and recommends that you vote **FOR** their election. If any nominee is unable or unwilling to serve as a director, which we do not anticipate, the Board, by resolution, may reduce the number of directors that constitute the Board or may choose a substitute. To be elected, a director must receive a majority of the votes cast with respect to that director at the meeting. Our By-laws provide that if the number of shares voted “for” any director nominee does not exceed 50% of the votes cast with respect to that director, he will tender his resignation to the Board of Directors. The Nominating and Governance Committee will then make a recommendation to the Board on whether to accept or reject the resignation, or whether other action should be taken.

The table below shows all of our director nominees; their ages, terms of office on our Board; experience within the past five years; and their qualifications we considered when inviting them to join our Board as well as nominating them for re-election. We believe that, as a general matter, our directors’ past five years of experience gives an indication of the wealth of knowledge and experience these individuals have and that we considered; however, we have also indicated the specific skills and areas of expertise we believe makes each of these individuals a valuable member of our Board.

Director Nominees

| <u>Director</u> | <u>Qualifications</u> |
|--|--|
| <p>Bradbury H, Anderson, 62 Director since 2011</p> <p>Vice Chairman and Chief Executive Officer — Best Buy Co., Inc. (multinational retailer of technology and entertainment products and services) from 2002 to 2009; President and Chief Operating Officer of Best Buy from 1991 to 2002.</p> <p>Director of General Mills, Inc. since 2007.</p> | <p>Mr. Anderson served in the positions of chief executive officer and chief operating officer of a large public retail company for several years, during a customer segmentation transformation, which provided him with extensive knowledge of management and operations of large public companies, including experience implementing customer focused strategies. He also has over 15 years of experience as a member of a public company board of directors.</p> |
| <p>Pastora San Juan Cafferty, 71 Director since 1994</p> <p>Professor Emerita — University of Chicago since June 2005; Professor — University of Chicago from 1985 to 2005; and faculty member from 1971 to 2005.</p> <p>Director of Integrys Energy Group, Inc., or one of its predecessors, since 1988.</p> <p>Director of BMO Financial Corp., a private corporation, since 1997.</p> <p>Director of Kimberly Clark Corporation from 1976 to 2007.</p> | <p>Ms. Cafferty has significant expertise in areas of public policy, strategic planning, and government and community relations through her 34-year professorship with the University of Chicago, as well as her experience serving on public boards and committees at the federal, state and local levels. Additionally, she has served as a director on multiple public company boards and brings over 30 years of board experience to the Company.</p> |

Director

Qualifications

Frank M. Clark, Jr., 66
Director since 2002

Chairman and Chief Executive Officer — ComEd (energy services company and subsidiary of Exelon Corporation) from November 2005 to February 2012; President — ComEd from 2001 to November 2005.

Executive Vice President and Chief of Staff — Exelon Corporation (public utility holding company) from 2004 to 2005; Senior Vice President — Exelon Corporation from 2001 to 2004.

Director of BMO Financial Corp., a private corporation, since 2005.

Director of Aetna, Inc. since 2006.

Mr. Clark served in executive positions at a large public utility company for over a decade, providing him with extensive experience and knowledge of large company management, operations and business critical functions. He also brings over nine years of experience as a member of a public company board of directors.

Patrick W. Gross, 67
Director since 2006

Chairman of The Lovell Group (private investment and advisory firm) since October 2001.

Director of Capital One Financial Corporation since 1995.

Director of Liquidity Services, Inc. since 2001.

Director of Career Education Corporation since 2005.

Director of Taleo Corporation since 2006.

Director of Rosetta Stone, Inc. since 2009.

Director of Computer Network Technology Corporation from 1997 to 2006.

Director of Mobius Management Systems, Inc. from 2002 to 2007.

Mr. Gross was a founder of American Management Systems, Inc., a global business and information technology firm, where he was principal executive officer for over 30 years. As a result, he has extensive experience in applying information technology and advanced data analytics in global companies. His background, education and board service also provide him with expertise in finance and accounting. He also brings over 30 years of experience as a director on public company boards of directors.

John C. Pope, 62
Non-Executive Chairman of the Board from 2004 through 2011;
Director since 1997

Chairman of the Board — PFI Group (private investment firm) since July 1994.

Director of R.R. Donnelley & Sons Company, or predecessor companies, since 1996.

Director of Dollar Thrifty Automotive Group, Inc. since 1997.

Director of Kraft Foods, Inc. since 2001.

Director of Con-way, Inc. since 2003.

Director of Federal Mogul Corporation from 1987 to 2007.

Prior to his current service on the boards of multiple major corporations, Mr. Pope served in executive operational and financial positions at large airline companies for almost 20 years, providing him with extensive experience and knowledge of management of large public companies with large-scale logistical challenges, high fixed-cost structure and significant capital requirements. His background, education and board service also provide him with expertise in finance and accounting. Mr. Pope has served as a director on many public company boards of directors during the last 30 years.

Director

Qualifications

W. Robert Reum, 69
Non-Executive Chairman of the Board since January 2012;
Director since 2003

Chairman, President and CEO — Amsted Industries Incorporated (diversified manufacturer for the railroad, vehicular and construction industries) since March 2001.

Mr. Reum has served as the chief executive of a private diversified manufacturing company for ten years. He also served as Chairman, President and Chief Executive Officer of The Interlake Corporation, a public diversified metal products company, from 1991 to 1999. As a result, he has extensive management experience within a wide range of business functions. Mr. Reum also brings over 15 years of experience as a director on public company boards of directors.

Steven G. Rothmeier, 65
Director since 1997

Chairman and CEO — Great Northern Capital (private investment management, consulting and merchant banking firm) since March 1993.

Director of Precision Castparts Inc. since 1994.

Director of GenCorp, Inc. from 2000 to 2006.

Director of Arvin Meritor, Inc. from 2004 to 2012.

Mr. Rothmeier served in executive operational and financial positions at a large airline company for several years. He also has many years of experience as an executive of asset management, venture capital and merchant banking firms. His experience and background provide him with a broad range of expertise in public company issues and expertise in finance and accounting. Mr. Rothmeier brings over 30 years of experience as a director of a wide range of public companies.

David P. Steiner, 51
Chief Executive Officer and Director since 2004;
President since June 2010

Executive Vice President and Chief Financial Officer from April 2003 to March 2004.

Director of TE Connectivity Ltd. (formerly Tyco Electronics Corporation) since 2007.

Director of FedEx Corporation since 2009.

Mr. Steiner is our President and Chief Executive Officer and, in that capacity, brings extensive knowledge of the details of our Company and its employees, as well as the front-line experiences of running our Company, to his service as a member of our Board. Mr. Steiner also brings his experience as a director of other major public companies.

Thomas H. Weidemeyer, 64
Director since 2005

Chief Operating Officer — United Parcel Service, Inc. (package delivery and supply chain services company) from 2001 to 2003; Senior Vice President — United Parcel Service, Inc. from 1994 to 2003.

President, UPS Airlines (UPS owned airline) from 1994 to 2003.

Director of NRG Energy, Inc. since 2003.

Director of The Goodyear Tire & Rubber Company since 2004.

Director of Amsted Industries Incorporated since 2007.

Mr. Weidemeyer served in executive positions at a large public company for several years. His roles encompassed significant operational management responsibility, providing him knowledge and experience in an array of functional areas critical to large public companies, including supply chain and logistics management. Mr. Weidemeyer also has over 11 years of experience as a director on public company boards of directors.

THE BOARD OF DIRECTORS RECOMMENDS THAT YOU VOTE FOR THE ELECTION OF EACH OF THE NINE NOMINEE DIRECTORS.

DIRECTOR NOMINEE AND OFFICER STOCK OWNERSHIP

Our Board of Directors has adopted stock ownership guidelines for our non-employee directors that require each director to hold Common Stock or share-based instruments valued at five times his annual cash retainer. Non-employee directors other than Mr. Reum currently are required to hold 17,500 shares and Mr. Reum currently is required to hold approximately 34,200 shares. Directors have five years from the later of the date they join the Board or the effective date of an increase in the holding requirements to attain the required level of ownership. Ms. Cafferty and Messrs. Clark, Pope and Rothmeier have reached their required levels of ownership. Mr. Gross and Mr. Weidemeyer have until July 2015 to reach their required level of ownership. Mr. Anderson has until August 2016 to reach his required level of ownership, and Mr. Reum has until January 2017 to reach his increased required level of ownership due to his election as Non-Executive Chairman of the Board effective January 1, 2012.

Our executive officers, including Mr. Steiner, are also subject to stock ownership guidelines, as described in the Compensation Discussion and Analysis on page 38 of this Proxy Statement.

The Stock Ownership Table below shows the number of shares of Common Stock each director nominee and each executive officer named in the Summary Compensation Table on page 39 owned as of March 13, 2012, our record date for the Annual Meeting, as well as the number owned by all directors and executive officers as a group. The table also includes information about restricted stock units, exercisable stock options and phantom stock granted under various compensation and benefit plans. Information about unearned performance share units granted to executive officers are not included in the table because the actual number of shares the executives may receive at the end of the performance period will vary depending on the level of achievement of the Company's financial objectives, and can vary from zero to two times the number of performance share units granted. As a result, the number of shares, if any, that will ultimately be issued pursuant to the performance share units is not known.

These individuals, both individually and in the aggregate, own less than 1% of our outstanding shares as of the record date.

Stock Ownership Table

| <u>Name</u> | <u>Shares of Common Stock Owned</u> | <u>Shares of Common Stock Covered by Exercisable Options</u> | <u>Phantom Stock(1)</u> |
|---|---|--|-----------------------------|
| Bradbury H. Anderson | 4,493 | 0 | 0 |
| Pastora San Juan Cafferty | 27,134 | 0 | 0 |
| Frank M. Clark, Jr. | 20,348 | 0 | 0 |
| Patrick W. Gross | 13,844 | 0 | 0 |
| John C. Pope(2) | 42,015 | 0 | 0 |
| W. Robert Reum | 19,903 | 0 | 0 |
| Steven G. Rothmeier | 19,749 | 0 | 0 |
| Thomas H. Weidemeyer | 15,877 | 0 | 0 |
| David P. Steiner(3) | 486,717 | 817,852 | 73,285 |
| Steven C. Preston | 0 | 0 | 0 |
| James E. Trevathan | 132,136 | 243,098 | 0 |
| Jeff M. Harris | 42,170 | 53,098 | 0 |
| Duane C. Woods(4) | 76,058 | 53,098 | 4,086 |
| Robert G. Simpson(5) | 110,780 | 153,093 | 0 |
| All directors and executive officers as a group (27 persons) | 1,347,000(6) | 1,915,495 | 94,558 |

(1) Executive officers may choose a Waste Management stock fund as an investment option under the Company's 409A Deferral Savings Plan described in the Nonqualified Deferred Compensation table on page 44. Interests in the fund are considered phantom stock because they are equal in value to shares of our Common Stock. Phantom stock receives dividend equivalents, in the form of additional phantom stock, at the same time that holders of shares of Common Stock receive dividends. The value of the phantom stock is paid

out, in cash, at a future date selected by the executive. Phantom stock is not considered as equity ownership for SEC disclosure purposes; we have included it in this table because it represents an investment risk in the performance of our Common Stock.

- (2) The number of shares owned by Mr. Pope includes 435 shares held in trusts for the benefit of his children.
- (3) Mr. Steiner has pledged 251,246 shares as security.
- (4) The number of shares owned by Mr. Woods includes 125 shares held by his children and 185 shares held by his wife's IRA.
- (5) Common Stock ownership is as of September 30, 2011, the date of Mr. Simpson's retirement from the Company.
- (6) Included in the "All directors and executive officers as a group" are 1,000 restricted stock units held by one of our executive officers not named in the table. Restricted stock units were granted to the executive officers under our 2009 Stock Incentive Plan. The restricted stock units will be paid out in shares of our Common Stock upon vesting, subject to forfeiture in certain circumstances.

PERSONS OWNING MORE THAN 5% OF WASTE MANAGEMENT COMMON STOCK

The table below shows information for stockholders known to us to beneficially own more than 5% of our Common Stock based on their filings with the SEC through March 13, 2012.

| <u>Name and Address</u> | <u>Shares Beneficially Owned</u> | |
|---|----------------------------------|-------------------|
| | <u>Number</u> | <u>Percent(1)</u> |
| Capital World Investors 333 South Hope Street Los Angeles, CA 90071 | 42,936,400(2) | 9.3 |
| Capital Research Global Investors 333 South Hope Street Los Angeles, CA 90071 | 29,137,102(3) | 6.3 |
| William H. Gates III One Microsoft Way Redmond, WA 98052 | 27,894,579(4) | 6.0 |
| Wellington Management Company, LLP 280 Congress Street Boston, MA 02210 | 27,225,692(5) | 5.9 |

- (1) Percentage is calculated using the number of shares of Common Stock outstanding as of March 13, 2012.
- (2) This information is based on a Schedule 13G/A filed with the SEC on February 10, 2012. Capital World Investors reports that it is deemed to be the beneficial owner of 42,936,400 shares of Common Stock as a result of acting as investment adviser to various investment companies. Capital World Investors reports that it holds more than five percent of such shares on behalf of its client, The Income Fund of America. Capital World Investors disclaims beneficial ownership of all shares.
- (3) This information is based on a Schedule 13G filed with the SEC on February 8, 2012. Capital Research Global Investors reports that it is deemed to be the beneficial owner of 29,137,102 shares of Common Stock as a result of acting as investment adviser to various investment companies. Capital Research Global Investors disclaims beneficial ownership of all shares.
- (4) This information is based on a Schedule 13G/A filed with the SEC on February 14, 2011, which is the most recent Schedule 13G available from this investor with respect to ownership of our Common Stock. Mr. Gates reports that he has sole voting and dispositive power over 9,260,907 shares of Common Stock held by Cascade Investment, L.L.C., as the sole member of such entity. Additionally, the Schedule 13G/A reports that Mr. Gates and Melinda French Gates share voting and dispositive power over 18,633,672 shares of Common Stock beneficially owned by Bill & Melinda Gates Foundation Trust.

- (5) This information is based on a Schedule 13G/A filed with the SEC on February 14, 2012. Wellington Management Company reports that it may be deemed to be the beneficial owner of 27,225,692 shares of Common Stock in its capacity as investment adviser.

SECTION 16(a) BENEFICIAL OWNERSHIP REPORTING COMPLIANCE

The federal securities laws require our executive officers and directors to file reports of their holdings and transactions in our Common Stock with the SEC and the New York Stock Exchange.

Based on a review of the forms and written representations from our executive officers and directors, we believe that all applicable requirements were complied with in 2011, except that Ms. Cowan, Senior Vice President, Customer Experience, was late in filing a Form 4 to report the acquisition of 100 shares of Common Stock on the open market.

EXECUTIVE OFFICERS

The following is a listing of our current executive officers, other than Mr. Steiner, whose personal information is included in the Director Nominees section of this Proxy Statement on page 16, their ages and business experience for the past five years.

| <u>Name</u> | <u>Age</u> | <u>Positions Held and Business Experience for Past Five Years</u> |
|-----------------------------|------------|--|
| David A. Aardsma | 55 | <ul style="list-style-type: none"> • Chief Sales and Marketing Officer since June 2011. • Senior Vice President, Sales and Marketing from January 2005 to June 2011. |
| Puneet Bhasin | 49 | <ul style="list-style-type: none"> • Senior Vice President and Chief Information Officer since December 2009. • Senior Vice President — Global Product & Technology, Monster Worldwide (provider of global online employment solutions) from April 2005 to November 2009. |
| William K. Caesar | 46 | <ul style="list-style-type: none"> • President, WM Recycle America, L.L.C., a wholly-owned subsidiary of the Company, since January 2012. • Chief Strategy Officer from July 2010 to January 2012. • Principal, McKinsey & Company (global management consulting firm) from July 2003 to June 2010. |
| Barry H. Caldwell | 51 | <ul style="list-style-type: none"> • Senior Vice President — Government Affairs and Corporate Communications since September 2002. |
| Grace M. Cowan | 53 | <ul style="list-style-type: none"> • Senior Vice President — Customer Experience since January 2011. • Senior Vice President — Customer Service, Operations, CNO Financial Group Inc. (insurance holding company) from October 2008 to December 2010. • Senior Vice President — National Practice Leader U.S., Aon Corporation (provider of risk management services, insurance and reinsurance brokerage and human resources consulting and outsourcing services) from June 2008 to October 2008. • Senior Vice President — Customer Service, Underwriting Operations, MetLife, Inc. (global provider of insurance, annuities and employee benefit programs) from 2000 to 2008. |
| James C. Fish, Jr. | 49 | <ul style="list-style-type: none"> • Senior Vice President, Eastern Group since June 2011. • Area Vice President, Pennsylvania and West Virginia Area from January 2009 to June 2011. • Market Area General Manager, Western Pennsylvania and West Virginia Market Area from February 2008 to January 2009. • Market Area General Manager, Rhode Island and Southern Massachusetts Market Area from September 2006 to February 2008. |
| Brett W. Frazier | 57 | <ul style="list-style-type: none"> • Senior Vice President — Southern Group since June 2011. • Senior Vice President — Eastern Group from June 2007 to June 2011. • Vice President — Collections Operation Support from February 2006 to June 2007. |

| <u>Name</u> | <u>Age</u> | <u>Positions Held and Business Experience for Past Five Years</u> |
|-------------------------------|------------|--|
| Jeff M. Harris | 57 | <ul style="list-style-type: none"> • Senior Vice President — Midwest Group since April 2006. |
| John J. Morris | 42 | <ul style="list-style-type: none"> • Chief Strategy Officer since March 2012. • Area Vice President — Greater Mid-Atlantic Area from July 2011 to March 2012. • Area Vice President — Waste Management of New Jersey from February 2007 to July 2011. |
| Steven C. Preston | 51 | <ul style="list-style-type: none"> • Executive Vice President — Finance, Recycling and Energy Services since October 2011. • President and Chief Executive Officer of Oakleaf Global Holdings, Inc. (provider of outsourced hauling, disposal, waste diversion and recycling services; the Company acquired Oakleaf in July 2011) from July 2009 to October 2011. • Secretary of the United States Department of Housing and Urban Development from June 2008 to January 2009. • Administrator of the United States Small Business Administration from June 2006 to June 2008. |
| Cherie C. Rice | 49 | <ul style="list-style-type: none"> • Vice President — Finance since May 2004, and Treasurer since January 2004. |
| Greg A. Robertson | 58 | <ul style="list-style-type: none"> • Vice President and Chief Accounting Officer since March 2004. |
| Carl V. Rush, Jr | 56 | <ul style="list-style-type: none"> • Senior Vice President — Organic Growth since December 2010. • Vice President — Organic Growth from January 2006 to December 2010. |
| James E. Trevathan | 59 | <ul style="list-style-type: none"> • Executive Vice President — Growth, Innovation and Field Support since June 2011. • Senior Vice President — Southern Group from July 2007 to June 2011. • Senior Vice President — Eastern Group from July 2004 to June 2007. |
| Mark A. Weidman | 55 | <ul style="list-style-type: none"> • President of Wheelabrator Technologies Inc., a wholly-owned subsidiary of the Company, since March 2006. |
| Rick L Wittenbraker | 64 | <ul style="list-style-type: none"> • Senior Vice President, General Counsel and Chief Compliance Officer since November 2003. |
| Duane C. Woods | 60 | <ul style="list-style-type: none"> • Senior Vice President — Western Group since July 2004. |

EXECUTIVE COMPENSATION

Compensation Discussion and Analysis

Executive Summary

The objective of our executive compensation program is to attract, retain, reward and incentivize exceptional, talented employees who will lead the Company in the successful execution of its strategy. The Company seeks to accomplish this goal by designing a compensation program that is supportive of and aligns with the strategy of the Company and the creation of stockholder value, while discouraging excessive risk-taking. The Company is dedicated to three transformational goals that we believe will drive continued growth and leadership in a dynamic industry: know more about our customers and how to service them than anyone else; use conversion and processing technology to extract more value from the materials we manage; and continuously improve our operational efficiency. The following key structural elements and policies further the objective of our executive compensation program:

- a substantial portion of executive compensation is linked to Company performance, through annual cash performance criteria and long-term incentive awards. As a result, our executive compensation program provides for a significant difference in total compensation in periods of above-target Company performance as compared to periods of below-target Company performance;
- performance goals are designed to be challenging, yet achievable;
- performance based awards include threshold, target and maximum payouts correlating to a range of performance and are based on a variety of indicators of performance, which limits risk-taking behavior;
- our compensation mix targets approximately 50% of total compensation of our named executives (and approximately 68% in the case of our Chief Executive Officer and President) to result from long-term equity awards, which aligns executives' interests with those of stockholders. The MD&C Committee altered the overall compensation allocation of operational leaders in 2011 to increase the weight of long-term equity compensation;
- performance stock units' three-year performance period, as well as stock options' vesting over a three-year period, link executives' interests with long-term performance and reduce incentives to maximize performance in any one year;
- all of our named executive officers are subject to stock ownership requirements, which we believe demonstrates a commitment to, and confidence in, the Company's long-term prospects;
- the Company has clawback provisions in its equity award agreements and recent employment agreements, as well as a general clawback policy, designed to recoup compensation in certain cases when cause and/or misconduct are found;
- our executive officer severance policy implemented a limitation on the amount of benefits the Company may provide to its executive officers under severance agreements entered into after the date of such policy; and
- the Company has adopted a policy that prohibits it from entering into new agreements with executive officers that provide for certain death benefits or tax gross-up payments.

The executive compensation program for 2011 fulfilled its objective by helping the Company manage through a challenging year and finish the year with strong fourth quarter results, poised to continue its progress on strategic growth initiatives and cost savings programs. For Waste Management, 2011 was a year of continued investment in the future, while also continuing to produce strong cash flows, return cash to our stockholders and take a disciplined approach to yield management. In line with the Company's 2011 financial results, the annual cash incentive awards for 2011 that are based on Company-wide performance metrics warranted a payout of 84.96% of target. This payout reflects that the Company exceeded the maximum performance level on its pricing improvement goal. However, the Company fell short of the threshold performance level for the income from operations margin performance goal, which substantially lowered the annual cash bonus payout. The Midwest

Group exceeded target level performance for income from operations excluding depreciation and amortization; whereas, the other geographic Groups' and Company-wide performance exceeded threshold, but fell short of target on this measure. Additionally, the Company is pleased to have generated a return on invested capital, for purposes of our performance share unit performance goals, that was well above threshold for the three-year performance period, resulting in an 86.99% payout on performance share units in shares of Common Stock. This is a positive development for the Company and executives, after zero payout was earned on performance share units in 2010 because threshold criteria was not met for the three-year performance period that ended December 31, 2010. The 2011 results have provided reassurance that our performance goals are challenging, but attainable. The MD&C Committee believes that the 2011 executive compensation plan successfully aligned our executive compensation structure with the overall Company strategy and motivated the performance we seek to reward. Accordingly, the compensation of the Company's executive officers set forth in the Summary Compensation Table of this Proxy Statement, whom we refer to as the "named executive officers" or "named executives," evidences our commitment to link executive pay with Company performance.

Consideration of Stockholder Advisory Vote and Recent Developments

The MD&C Committee established the 2011 compensation plan in early 2011, before the stockholder advisory vote on executive compensation in May 2011. However, the MD&C Committee has since noted the results of the advisory stockholder vote, with 97% of shares present and entitled to vote at the annual meeting voting in favor of the Company's executive compensation. Accordingly, the results of the stockholder advisory vote have not caused the MD&C Committee to recommend any changes to our compensation practices.

The Company continues to adapt its compensation program to best support our strategy and the accomplishment of our goals. As a result, the MD&C Committee has approved the changes described below to our executive compensation program for 2012:

- *Annual Cash Bonus Performance Goals:* We have adopted a new performance measure designed to increase our focus on controlling costs, based on operating expense, plus selling, general & administrative expense, as a percentage of net revenue. We have also adopted a new cash flow performance measure, based on income from operations excluding depreciation and amortization less capital expenditures, which is designed to increase our focus on disciplined capital spending. These two new measures, together with our current income from operations margin measure, will make up the three performance measures for our 2012 annual cash bonuses and will be equally weighted.
- *Allocation of Long-Term Incentive Plan Awards:* We have increased the weighting of performance share units, which are dependant on achievement of specified performance measures, from 30%, in 2011, to 80% of the total value of each named executive's annual long-term incentive plan award for 2012. Stock options will continue to encourage and reward stock price appreciation and will comprise the remaining 20% of the total value of each named executive's award.
- *Performance Share Unit Performance Goals:* Half of the performance share units granted in 2012 will retain the return on invested capital performance measure; while the remaining half of all performance share units granted in 2012 will be dependant on a new performance measure based on total shareholder return relative to the S&P 500. All performance share units will continue to have a three-year performance period.

Our Compensation Philosophy for Named Executive Officers

The Company's compensation philosophy is designed to:

- Attract and retain exceptional employees through competitive compensation opportunities;
- Encourage and reward performance through substantial at-risk performance-based compensation; and
- Align our decision makers' long-term interests with those of our stockholders through emphasis on equity ownership.

Additionally, as the Company pursues its transformation strategy, our compensation philosophy is intended to encourage executives to embrace the change necessary to achieve the Company's goals and to lead the Company in setting aspirations that will drive a change in Company-wide culture.

With respect to our named executive officers, the MD&C Committee believes that total direct compensation at target should be in a range around the competitive median according to the following:

- Base salaries should be paid within a range of plus or minus 10% around the competitive median, but attention must be given to individual circumstances, including strategic importance of the named executive's role, the executive's experience and individual performance;
- Short-term incentive opportunities should be within a range of plus or minus 15% around the competitive median; and
- Long-term incentive opportunities should be within a range of plus or minus 20% around the competitive median.

Overview of Elements of Our 2011 Compensation Program

| <u>Timing</u> | <u>Component</u> | <u>Purpose</u> | <u>Key Features</u> |
|----------------------------------|-------------------|---|---|
| Current | Base Salary | To attract and retain executives with a competitive level of regular income appropriate for respective positions and responsibilities | Adjustments to base salary primarily consider competitive market data for cost of labor increases and executive's individual performance and impact on the Company. Base salary adjustments are also considered when an executive takes on a new position and/or additional responsibilities. |
| Short-Term Performance Incentive | Annual Cash Bonus | To encourage and reward contributions to our annual financial performance objectives through at-risk compensation subject to challenging, objective and transparent metrics | Bonuses are targeted at a percentage of base salary and could range from zero to 280% of target based on: <ul style="list-style-type: none"> • Income from Operations excluding Depreciation and Amortization- encourages generation of cash flow, which drives stockholder value (40%); upon achieving this performance goal, a payout multiplier based on revenue growth could be triggered; • Income from Operations Margin- motivates employees to control and lower costs and operate efficiently, thereby increasing our income from operations as a percentage of revenues (30%); and • Pricing Improvement- promotes discipline in executing our pricing programs to ensure we receive strong operating margins on volumes (30%). <p>The MD&C Committee has discretion to increase or decrease an individual's payment by up to 25% based on individual performance, but such modifier has never been used to increase a payment to a named executive.</p> |

| <u>Timing</u> | <u>Component</u> | <u>Purpose</u> | <u>Key Features</u> |
|----------------------------------|-------------------------|--|--|
| Long-Term Performance Incentives | Performance Share Units | To encourage and reward building long-term stockholder value through profitable allocation of capital; To retain executives; and To increase stockholder alignment through executives' stock ownership | Number of shares delivered can range from zero to 200% of the initial target grant based on return on invested capital, or ROIC, over a three-year performance period. Grants are generally forfeited if the executive voluntarily terminates his employment. PSUs earn dividend equivalents based on the number of shares actually awarded. Recipients can defer the receipt of shares, which are paid out in shares of Common Stock, without interest, at the end of the deferral period. |
| | Stock Options | To encourage and reward stock price appreciation over the long-term; To retain executives; and To increase stockholder alignment through executives' stock ownership | Supports the growth element of the Company's strategy. Stock options vest in 25% increments on the first two anniversaries of the date of grant and the remaining 50% vest on the third anniversary. Exercise price is the average of the high and low market price of our Common Stock on the date of grant. Stock options have a term of ten years. Unvested options are generally forfeited if the executive voluntarily terminates his employment. |

Post-Employment and Change-in-Control Compensation. The compensation our named executives receive post-employment is based on provisions included in individual equity award agreements, retirement plan documents and employment agreements. We enter into employment agreements with our named executive officers because they encourage continuity of our leadership team, which is particularly valuable as leadership manages the Company through the change needed to successfully implement our transformational business strategy. Employment agreements also provide a form of protection for the Company through restrictive covenant provisions, and they provide the individual with comfort that he will be treated fairly in the event of a termination not for cause or under a change-in-control situation. The change-in-control provision included in each named executive officer's agreement requires a double trigger in order to receive any payment in the event of a change-in-control situation. First, a change-in-control must occur, and second the individual must terminate his employment for good reason or the Company must terminate his employment without cause within six months prior to or two years following the change-in-control event. Our stock option awards are also subject to double trigger vesting in the event of a change-in-control situation. Performance share units will be paid out in cash on a prorated basis based on actual results achieved through the end of the fiscal quarter prior to a change-in-control. Thereafter, the executive would typically receive a replacement award of restricted stock units in the successor entity. We believe providing change-in-control protection encourages our named executives to pursue and facilitate change-in-control transactions that are in the best interests of stockholders while not granting executives an undeserved windfall.

Deferral Plan. Each of our named executive officers is eligible to participate in our 409A Deferral Savings Plan. The plan allows all employees with a minimum base salary of \$170,000 to defer up to 25% of their base salary and up to 100% of their annual bonus ("eligible pay") for payment at a future date. Under the plan, the Company matches the portion of pay that cannot be matched in the Company's 401(k) Savings Plan due to IRS limits. The Company match provided under the 401(k) Savings Plan and the Deferral Plan is dollar for dollar on the first 3% of eligible pay, and fifty cents on the dollar for the next 3% of eligible pay. Participants can contribute the entire amount of their eligible pay to the Deferral Plan. Contributions in excess of the 6% will not be matched but will be tax-deferred. Company matching contributions begin in the Deferral Plan once the employee has reached the IRS limits in the 401(k) plan. Amounts deferred under this plan are allocated into

accounts that mirror selected investment funds in our 401(k) plan, although the amounts deferred are not actually invested in the funds. We believe that providing a program that allows and encourages planning for retirement is a key factor in our ability to attract and retain talent. Additional details on the plan can be found in the Nonqualified Deferred Compensation table and the footnotes to the table on page 44.

Perquisites. Based on a periodic security assessment by an outside consultant, for security purposes, the Company requires the Chief Executive Officer and President to use the Company's aircraft for business and personal use. Use of the Company's aircraft is permitted for other employees' personal use only with Chief Executive Officer approval in special circumstances, which seldom occurs. The value of our named executives' personal use of the Company's airplanes is treated as taxable income to the respective executive in accordance with IRS regulations using the Standard Industry Fare Level formula. This is a different amount than we disclose in the Summary Compensation Table, which is based on the SEC requirement to report the incremental cost to us of their use. We also reimburse the cost of physical examinations for our senior executives, as we believe it is beneficial to the Company to facilitate its executives receiving preventative healthcare. Other than as described in this paragraph, we have eliminated all perquisites for our named executive officers.

Our Named Executive Officers

Our named executive officers for 2011 are:

- Mr. David Steiner- has served Waste Management as Chief Executive Officer since 2004 and President since June 2010.
- Mr. Steven Preston- recruited to join Waste Management as Executive Vice President – Finance, Recycling and Energy Services in October 2011 and became Waste Management's principal financial officer upon Mr. Robert Simpson's retirement. Mr. Preston was previously President and Chief Executive Officer of Oakleaf Global Holdings, which Waste Management acquired in July 2011.
- Mr. Robert Simpson- served Waste Management as Senior Vice President and Chief Financial Officer from March 2004 until his retirement effective September 30, 2011.
- Mr. James Trevathan- was appointed to the new position of Executive Vice President – Growth, Innovation and Field Support in June 2011 after having most recently served Waste Management as Senior Vice President of the Southern Group since 2007.
- Mr. Jeff Harris- has served Waste Management as Senior Vice President of the Midwest Group since April 2006.
- Mr. Duane Woods- has served Waste Management as Senior Vice President of the Western Group since July 2004.

How Named Executive Officer Compensation Decisions are Made

The MD&C Committee meets several times each year to perform its responsibilities as delegated by the Board of Directors and as set forth in the MD&C Committee's charter. These responsibilities include evaluating and approving the Company's compensation philosophy, policies, plans and programs for our named executive officers.

In the performance of its duties, the MD&C Committee regularly reviews the total compensation, including the base salary, target annual bonus award opportunities, long-term incentive award opportunities and other benefits, including potential severance payments for each of our named executive officers. At a regularly scheduled meeting each year, the MD&C Committee reviews our named executives' total compensation and compares that compensation to the competitive market, as discussed below. In the first quarter of each year, the MD&C Committee meets to determine salary increases, if any, for the named executive officers; verifies the results of the Company's performance for annual incentive and performance share unit calculations; reviews the individual annual incentive targets for the current year as a percent of salary for each of the named executive officers; and makes decisions on granting long-term equity awards.

Compensation Consultant. The MD&C Committee uses several resources in its analysis of the appropriate compensation for the named executive officers. The MD&C Committee selects and employs an independent

consultant to provide it advice relating to market and general compensation trends. The MD&C Committee also uses the services of its independent consultant for data gathering and analyses. The MD&C Committee has retained Frederic W. Cook & Co., Inc. as its independent consultant since 2002. The Company makes regular payments to Frederic W. Cook for its services around executive compensation, including meeting preparation and attendance, advice, best practice information, as well as competitive data. Information about such payments is submitted to the chair of the MD&C Committee.

In addition to services related to executive compensation, the consultant also provides the Board of Director's Nominating and Governance Committee information and advice considered when recommending compensation of the independent directors. Frederic W. Cook has no other business relationships with the Company and receives no other payments from the Company. The MD&C Committee adopted a written policy to ensure the independence of any compensation consultants it uses for executive compensation matters. Pursuant to the policy, no compensation consultant engaged by the MD&C Committee to assist in determining or recommending the compensation of executive officers or independent directors of the Board of Directors may be engaged by management of the Company unless first approved by the MD&C Committee. Since the adoption of the policy, no engagements have been proposed to the MD&C Committee for approval.

Role of CEO. Mr. Steiner contributes to compensation determinations by assessing the performance of the named executive officers reporting to him and providing these assessments with recommendations to the MD&C Committee. Personnel within the Company's People Department assist the MD&C Committee by working with the independent consultant to provide information requested by the MD&C Committee and assisting it in designing and administering the Company's incentive programs.

Peer Company Comparisons. The MD&C Committee uses compensation information of comparison groups of companies to gauge the competitive market, which is relevant for attracting and retaining key talent and for ensuring that the Company's compensation practices are aligned with prevalent practices. For purposes of establishing the 2011 executive compensation program, the MD&C Committee considered a competitive analysis of total direct compensation levels and compensation mixes for our executive officers, using information from:

- two general industry surveys as provided by management; the Hewitt Associates 2010 TCM Executive Total Compensation Survey and the Towers Watson 2010 U.S. General Industry Executive Database. The competitive consensus for top five named executive officers consists of an equally-weighted average of comparison company median data and size-adjusted median data from both general industry surveys; and
- a comparison group of 20 companies, described below.

The comparison group of companies is initially recommended by the independent consultant prior to the actual data gathering process, with input from management. The composition of the group is evaluated and a final comparison group of companies is approved by the MD&C Committee each year. The selection process for the comparison group begins with all companies in the Standard & Poor's North American database that are publicly traded U.S. companies in 17 different Global Industry Classifications. These industry classifications are meant to provide a collection of companies in industries that share similar characteristics with Waste Management. The companies are then limited to those with at least \$5 billion in annual revenue to ensure appropriate comparisons, and further narrowed by choosing those with asset intensive domestic operations, as well as those focusing on transportation and logistics. Companies with these characteristics are chosen because the MD&C Committee believes that it is appropriate to compare our executives' compensation with executives that have similar responsibilities and challenges at other companies. The MD&C Committee received a statistical analysis of the growth profile, profitability profile, size and shareholder return of all companies in the comparison group to verify that the Company is appropriately positioned versus the comparison group. This analysis revealed the Company's composite percentile rankings among the companies in the comparison group based on numerous statistical measures were as follows: growth profile – 43%; profitability profile – 54%; size

profile – 48%; and shareholder return profile – 73%. The comparison group used for consideration of 2011 compensation was composed of the companies listed below:

| | |
|------------------------------|-----------------------|
| American Electric Power | NextEra Energy |
| Baker Hughes | Norfolk Southern |
| Burlington Northern Santa Fe | Republic Services |
| CH Robinson | Ryder |
| CSX | Schlumberger |
| Entergy | Southern Company |
| FedEx | Sysco |
| Grainger | Union Pacific |
| Halliburton | United Parcel Service |
| Hertz | YRC Worldwide |

The general industry data and the comparison group data are blended when composing the competitive analysis, when possible, such that the combined general industry data and the comparison group are each weighted 50%. The competitive analysis showed that the Company's named executives' 2011 total direct compensation opportunities are positioned in a range around the median of the compensation of the executives comprising the competitive analysis, and none of our named executive officers' total direct compensation is above the range around the median for their peers in the competitive analysis. For competitive comparisons, the MD&C Committee has determined that total direct compensation packages for our named executive officers within a range of plus or minus twenty percent of the median total compensation of the competitive analysis is appropriate. In making these determinations, total direct compensation consists of base salary, target annual bonus, and the annualized grant date fair value of long-term equity incentive awards.

Allocation of Compensation Elements and Tally Sheets. The MD&C Committee considers the forms in which total compensation will be paid to executive officers and seeks to achieve an appropriate balance between base salary, annual cash incentive compensation and long-term incentive compensation. The MD&C Committee determines the size of each element based primarily on comparison group data and individual and Company performance. The percentage of compensation that is contingent on achievement of performance criteria typically increases in correlation to an executive officer's responsibilities within the Company, with at-risk performance-based incentive compensation making up a greater percentage of total compensation for our most senior executive officers. Additionally, as an executive becomes more senior, a greater percentage of the executive's compensation shifts away from short-term to long-term incentive awards.

The MD&C Committee uses tally sheets to review the compensation of our named executive officers, which show the cumulative impact of all elements of compensation. These tally sheets include detailed information and dollar amounts for each component of compensation, the value of all equity held by each named executive, and the value of welfare and retirement benefits and severance payments. Tally sheets provide the MD&C Committee with the relevant information necessary to determine whether the balance between long-term and short-term compensation, as well as fixed and variable compensation, is consistent with the overall compensation philosophy of the Company. This information is also useful in the MD&C Committee's analysis of whether total direct compensation provides a compensation package that is appropriate and competitive. Tally sheets are provided to the full Board of Directors.

The following charts display the allocation of total 2011 compensation among base salary, annual cash incentive at target and long-term incentives at target for our Chief Executive Officer and President and for Messrs. Trevathan (prior to his promotion), Harris and Woods, on average. In the process of establishing the 2011 executive compensation program, the MD&C Committee determined that the compensation of our Senior Group Vice President position was weighted too heavily in favor of short-term incentives in comparison to our peers. As a result, the MD&C Committee revised the allocation of 2011 targeted compensation of Senior Group Vice Presidents that are named executives as shown below to shift emphasis toward long-term incentives. Accordingly, these charts reflect the MD&C Committee's 2011 desired total mix of compensation for Senior

Group Vice Presidents, which includes approximately 49% of total compensation relating to long-term equity, while long-term equity comprises almost 68% of Mr. Steiner’s total compensation.

Chief Executive Officer and President

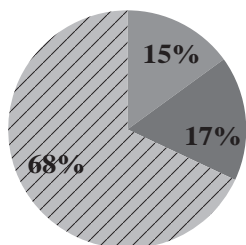

Senior Group Vice Presidents (average)

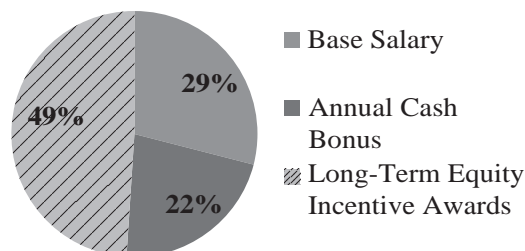

- Base Salary
- Annual Cash Bonus
- ▨ Long-Term Equity Incentive Awards

Internal Pay Equity. The MD&C Committee considers the differentials between compensation of the individual named executive officers, as well as the additional responsibilities of the Chief Executive Officer and President compared to the other executive officers. Internal comparisons are also made between executive officers and their direct reports. The MD&C Committee confirms that the compensation paid to executive officers is reasonable compared to that of their direct reports, while recognizing that an executive’s actual total compensation, as a multiple of the total compensation of his or her subordinates, will increase in periods of above-target performance and decrease in times of below-target performance.

Tax and Accounting Matters. Section 162(m) of the Internal Revenue Code of 1985, as amended (“Code Section 162(m)”), denies a compensation deduction for federal income tax purposes for certain compensation in excess of \$1 million paid to our Chief Executive Officer and President and our other three highest paid executives who are employed on the last day of our fiscal year. “Performance based” compensation meeting specified standards is deductible without regard to the \$1 million cap. We design our compensation plans to be tax efficient for the Company where possible. However, our MD&C Committee reserves the right to structure the compensation of our executive officers without regard for whether the compensation is fully deductible if, in the MD&C Committee’s judgment, it is in the best interests of the Company and stockholders to do so.

The annual bonus plan is designed to comply with the performance-based compensation exemption under Code Section 162(m) by allowing the MD&C Committee to set performance criteria for payments, which may not exceed the predetermined amount of 0.5% of the Company’s pre-tax income per participant. Our performance share unit awards are also intended to meet the qualified performance-based compensation exception under Code Section 162(m).

Section 409A of the Internal Revenue Code of 1986, as amended (“Code Section 409A”), generally provides that any deferred compensation arrangement which does not meet specific requirements will result in immediate taxation of any amounts deferred to the extent not subject to a substantial risk of forfeiture. In general, to avoid a Code Section 409A violation, amounts deferred may only be paid out on separation from service, disability, death, a specified time or fixed schedule, a change-in-control or an unforeseen emergency. Furthermore, the election to defer generally must be made in the calendar year prior to performance of services. We intend to structure all of our compensation arrangements, including our Deferral Plan, in a manner that complies with or is exempt from Code Section 409A.

We account for stock-based payments, including stock options and performance share units, in accordance with Financial Accounting Standards Board Accounting Standards Codification Topic 718, Stock Compensation. The MD&C Committee takes into consideration the accounting treatment under ASC Topic 718 when determining the form and amount of annual long-term equity incentive awards. However, because our long-term equity incentive awards are based on a target dollar value established prior to grant (described in further detail under “Named Executives’ 2011 Compensation Program and Results — Long-Term Equity Incentives”), this “value” will differ from the grant date fair value of awards calculated pursuant to ASC Topic 718.

Risk Assessment. The MD&C Committee uses the structural elements set forth in the Executive Summary above to establish compensation that will provide sufficient incentives for named executive officers to drive results while avoiding unnecessary or excessive risk taking that could harm the long-term value of the

Company. During 2011, the MD&C Committee reviewed the Company's assessment of risk created by the Company's compensation policies and practices, which was conducted with guidance from the independent compensation consultant. The MD&C Committee concluded that our compensation policies and practices do not create risks that are reasonably likely to have a material adverse effect on the Company.

Consideration of Stockholder Advisory Vote on Executive Compensation. The MD&C Committee reviews the results of the stockholder advisory vote on executive compensation and considers any implications of such voting results on the Company's compensation programs.

Recruitment of Mr. Preston and Promotion of Mr. Trevathan. In light of Mr. Simpson's desire to retire, the Company conducted a search for a new principal financial officer. Mr. Preston, previously President and Chief Executive Officer of Oakleaf Global Holdings, was identified as the desired successor following Waste Management's acquisition of Oakleaf in July 2011. Mr. Preston is our only named executive recruited to his position from outside the Company. When establishing compensation for Mr. Preston, the MD&C Committee considered the compensation level of his predecessor and the competitive analysis prepared when 2011 executive compensation was established. The MD&C Committee determined that an increased base salary was justified on the basis of the competitive analysis, as well as the fact that Mr. Preston assumed oversight responsibilities for recycling, waste-to-energy and organic growth operations in addition to responsibilities of the principal financial officer. Additionally, the MD&C Committee concluded that it was appropriate to guarantee Mr. Preston an annual cash bonus for 2011 to entice him to take on a new employment opportunity. The MD&C Committee also approved an award to Mr. Preston of 184,584 stock options under the Company's 2009 Stock Incentive Plan with the same term and vesting provisions as stock options awarded to other named executives in 2011. This equity award was granted as a component of Mr. Preston's overall competitive compensation package, as well as to encourage and reward long-term performance, promote retention and increase Mr. Preston's alignment with stockholders.

Additionally, in June 2011, Mr. Trevathan was promoted to the new position of Executive Vice President — Growth, Innovation and Field Support. In this new role, Mr. Trevathan is responsible for integrating the Company's operations, sales and people functions to support the field's achievement of the Company's transformational growth goals. He is working in close coordination with the Company's Group Senior Vice Presidents. Company functions reporting into Mr. Trevathan include the corporate staff in Collection and Post-Collection Operations, Safety, Procurement, Innovation & Optimization, Business Solutions, Enterprise Program Integration, Sales & Marketing, and Human Resources. In recognition of this promotion and the strategic importance of the additional responsibilities that Mr. Trevathan assumed, Mr. Trevathan received an award of 150,000 stock options under the Company's 2009 Stock Incentive Plan with the same term and vesting provisions as stock options awarded to other named executives in 2011.

Named Executives' 2011 Compensation Program and Results

Base Salary

Each of Mr. Steiner and Mr. Simpson received a 2.5% increase in base salary, in line with the corporate-level budget. In early 2011, the base salaries of the Group Senior Vice Presidents were determined to be on the high side of our target range around the competitive median, and as a result, none of the Group Senior Vice Presidents that are named executives received an increase in base salary for the second year in a row. Mr. Preston's base salary was established in connection with his recruitment to the Company, as discussed above. The table below shows the 2010 base salary, percent increase in base salary and 2011 base salary for each of our named executive officers:

| <u>Named Executive Officer</u> | <u>2010 Base Salary</u> | <u>Percent Increase</u> | <u>2011 Base Salary</u> |
|--------------------------------|-------------------------|-------------------------|-------------------------|
| Mr. Steiner | \$1,100,000 | 2.5 | \$1,127,500 |
| Mr. Preston | N/A | N/A | \$ 580,000 |
| Mr. Simpson | \$ 531,405 | 2.5 | \$ 544,690 |
| Mr. Trevathan | \$ 566,298 | 0 | \$ 566,298 |
| Mr. Harris | \$ 536,278 | 0 | \$ 536,278 |
| Mr. Woods | \$ 565,710 | 0 | \$ 565,710 |

Annual Cash Bonus

- Annual cash bonuses were dependant on the following metrics: *Income from Operations excluding Depreciation and Amortization (weighted 40%); Income from Operations Margin (weighted 30%) and Pricing Improvement (weighted 30%).*
- Actual bonus payments made in March 2012 for fiscal 2011 were: 84.96% of target for Mr. Steiner, based on Company-wide performance, and were 84.96%, 109.24% and 84.96% of target for Messrs. Trevathan, Harris and Woods, respectively, based on a combination of individual, Company-wide and field-level performance.

For purposes of 2011 annual cash bonuses for corporate-level employees, including Mr. Steiner, performance is measured using the Company's consolidated results of operations. The table below details the Company-wide performance measures set by the MD&C Committee for the corporate-level named executive officers' bonuses earned in 2011.

| | <u>Threshold Performance*</u> | <u>Target Performance (100% Payment)</u> | <u>Maximum Performance (200% Payment)</u> |
|---|-----------------------------------|--|---|
| Income from Operations Margin | 15.84% | 17.60% | 19.36% |
| Income from Operations excluding Depreciation and Amortization** | \$3,268 million | \$3,631 million | \$3,994 million |
| Pricing Improvement*** | 2.2% | 2.6% | 3.0% |

* Achievement of threshold performance yields a 60% payout level for the income from operations excluding depreciation and amortization metric and the pricing improvement metric and a 93.4% payout on the income from operations margin metric.

** The design of the 2011 annual bonus plan provided that, upon achieving target level performance on the income from operations excluding depreciation and amortization metric, the payout associated with this metric could be doubled based on year-over-year revenue growth. However, because the income from operations excluding depreciation and amortization metric fell below target (as detailed further below), the revenue growth multiplier was not applicable.

*** Calculated using weighted average rate per unit increase, based on commercial and industrial collection operations; transfer stations; and municipal solid waste and construction and demolition volumes at our landfills, but excluding new business, special waste and residential waste. The pricing measures used for these calculations are not the same as "yield" as we present in any of our disclosures, such as the Management's Discussion and Analysis section of our Forms 10-K and 10-Q or our earnings press releases, and the targeted increases shown in the table should not be construed as a targeted increase in "yield" as discussed in those disclosures.

The 2011 annual cash bonuses of Messrs. Trevathan, Harris and Woods were calculated using (i) the Company's consolidated results of operations for measuring income from operations margin and pricing improvement and (ii) their respective field-based results of operations for measuring income from operations excluding depreciation and amortization. (With respect to Mr. Trevathan, his performance calculation was prorated to take account of field-based results for the period of 2011 before he was promoted to his current corporate-level position.) The MD&C Committee then has discretion to increase or decrease an individual's payment by up to 25% based on individual performance. The MD&C Committee has never used this modifier to increase a payment to a named executive; however, as detailed below, this modifier was used to lower named executives' annual cash bonuses for 2011. We believe using field-based results for income from operations excluding depreciation and amortization is appropriate because it ties our field-based named executive officers' compensation directly to the success or failure of operations that receive their primary attention. In the case of Messrs. Trevathan and Woods, the measure income from operations excluding depreciation and amortization was comprised of two separate calculations. The first calculation (weighted 70%) was based solely on results of operations for their respective Group; the second calculation (weighted 30%) was based on results of operations for their respective Group, as integrated with operations of our Wheelabrator subsidiary that are not a component

of the Group's calculated results for financial reporting purposes, but which are located physically within the Group's geographic area. This calculation, which we refer to as the Group's "integrated" performance measure, is intended to encourage the operating business units within the geographic Groups to support and collaborate with Wheelabrator's operating business units in their area. The following table sets forth the income from operations excluding depreciation and amortization performance measure, on a stand-alone and an integrated basis, as set by the MD&C Committee for the respective Groups of Messrs. Trevathan, Harris and Woods:

| | Threshold Performance (60% Payment) | Target Performance (100% Payment) | Maximum Performance (200% Payment) |
|---|--|--|---|
| | (In millions) | (In millions) | (In millions) |
| Southern Group (Mr. Trevathan) | \$1,061 | \$1,179 | \$1,297 |
| Integrated: Southern Group (Mr. Trevathan) | \$1,137 | \$1,263 | \$1,389 |
| Midwest Group (Mr. Harris) | \$ 841 | \$ 934 | \$1,027 |
| Integrated: Midwest Group (Mr. Harris) | N/A | N/A | N/A |
| Western Group (Mr. Woods) | \$ 784 | \$ 871 | \$ 958 |
| Integrated: Western Group (Mr. Woods) | \$ 793 | \$ 881 | \$ 969 |

The following table sets forth the Company's performance achieved on each of the annual cash bonus performance goals on a Company-wide consolidated basis, the payout earned on account of such performance, and the calculation of Mr. Steiner's annual cash bonus payout based on such goals.

Calculation of Annual Cash Bonus Payout for Mr. Steiner:

| | Income from Operations excluding Depreciation and Amortization: (weighted 40%) | | Income from Operations Margin: (weighted 30%) | | Pricing Improvement: (weighted 30%) | | Total Payout Earned (as a percentage of Target) |
|--|---|------------------|--|------------------|--|------------------|--|
| | Actual | Payout Earned | Actual | Payout Earned | Actual | Payout Earned | |
| Company Consolidated | \$3,290 million | 62.40% | 15.77% | 0% | 3.2% | 200% | ----- |
| Payout Based on Performance | | | | | | | |
| Measures | | | | | | | 84.96% |
| Individual Performance Modifier | | | | | | | 100% |
| Modified Payout | | | | | | | 84.96% |

The following three tables set forth the calculation of the annual cash bonus payout for Messrs. Trevathan, Harris and Woods, respectively. As reflected below and as explained in more detail two paragraphs above, these individuals' payouts were based on performance achieved on a combination of Company-wide and field-level goals and individual performance.

Calculation of Annual Cash Bonus Payout for Mr. Trevathan:

| | Income from Operations excluding Depreciation and Amortization: (weighted 40%) | | Income from Operations Margin: (weighted 30%) | | Pricing Improvement: (weighted 30%) | | Total Payout Earned (as a percentage of Target) |
|---|---|-------------------|--|------------------|--|------------------|--|
| | Actual | Payout Earned* | Actual | Payout Earned | Actual | Payout Earned | |
| Company Consolidated | \$3,290 million | 62.40% | 15.77% | 0% | 3.2% | 200% | ----- |
| Southern Group (weighted 70%) | \$1,067 million | 62.04% | | | | | |
| Southern Integrated (weighted 30%) | \$1,150 million | 64.60% | | | | | |
| Payout Based on Performance | | | | | | | |
| Measures | | | | | | | 85.03% |
| Individual Performance Modifier | | | | | | | 99.9% |
| Modified Payout | | | | | | | 84.96% |

* This calculation was prorated to take account of field-based results for the period of 2011 before Mr. Trevathan was promoted to his current corporate-level position.

Calculation of Annual Cash Bonus Payout for Mr. Harris:

| | Income from Operations excluding Depreciation and Amortization: (weighted 40%) | | Income from Operations Margin: (weighted 30%) | | Pricing Improvement: (weighted 30%) | | Total Payout Earned (as a percentage of Target) |
|---------------------------------------|---|------------------|---|------------------|--|------------------|--|
| | Actual | Payout Earned | Actual | Payout Earned | Actual | Payout Earned | |
| Company Consolidated | | | 15.77% | 0% | 3.2% | 200% | |
| Midwest Group | \$956 million | 123.10% | | | | | |
| Payout Based on Performance | | | | | | | |
| Measures | | | | | | | 109.24% |
| Individual Performance Modifier . . . | | | | | | | 100% |
| Modified Payout . . . | | | | | | | 109.24% |

Calculation of Annual Cash Bonus Payout for Mr. Woods:

| | Income from Operations excluding Depreciation and Amortization: (weighted 40%) | | Income from Operations Margin: (weighted 30%) | | Pricing Improvement: (weighted 30%) | | Total Payout Earned (as a percentage of Target) |
|--|---|------------------|---|------------------|--|------------------|--|
| | Actual | Payout Earned | Actual | Payout Earned | Actual | Payout Earned | |
| Company Consolidated | | | 15.77% | 0% | 3.2% | 200% | |
| Western Group (weighted 70%) | \$820 million | 76.84% | | | | | |
| Western Integrated (weighted 30%) | \$829 million | 76.04% | | | | | |
| Payout Based on Performance | | | | | | | |
| Measures | | | | | | | 90.64% |
| Individual Performance Modifier . . . | | | | | | | 93.7% |
| Modified Payout . . . | | | | | | | 84.96% |

In determining actual performance achieved on financial performance goals, the MD&C Committee has discretion to make adjustments to the calculations for unusual or otherwise non-operational matters that it believes do not accurately reflect results of operations expected from management for bonus purposes. In 2011, the calculation of income from operations excluding depreciation and amortization and income from operations margin were adjusted to exclude the effects of: (i) revisions of estimates associated principally with remedial liabilities at a closed site; (ii) the accounting effect of changes in ten-year Treasury rates, which are used to discount remediation reserves; (iii) restructuring undertaken as part of our cost savings programs; (iv) impairments at two closed Healthcare Solutions facilities; and (v) charges related to integration of the acquired Oakleaf business and Oakleaf operating losses. Adjustments are not made to forgive poor performance, and the MD&C Committee considers both positive and negative adjustments to results. Adjustments are made to ensure that rewards are aligned with the right business decisions and are not influenced by potential short-term gain or impact on bonuses. Adjusting for certain items, like those discussed herein, avoids creating incentives for individuals to fail to take actions for the longer-term good of the Company in order to meet short-term goals. The aggregate net impact of the adjustments mentioned above resulted in a \$43.12 million increase in income from operations excluding depreciation and amortization on a Company-wide consolidated basis. These adjustments also increased field-level and integrated income from operations excluding depreciation and amortization to the extent applicable to the respective geographic Groups.

The following table shows each named executive's target percentage of base salary, percentage of target earned in 2011, and amount of annual cash bonus for 2011.

| <u>Named Executive Officer</u> | <u>Target Percentage of Base Salary</u> | <u>Percentage of Target Earned in 2011</u> | <u>Annual Cash Bonus For 2011</u> |
|--------------------------------|---|--|-----------------------------------|
| Mr. Steiner | 115 | 84.96% | \$1,095,356 |
| Mr. Preston* | 85 | — | \$ 510,000 |
| Mr. Simpson** | 85 | — | — |
| Mr. Trevathan | 75 | 84.96% | \$ 360,845 |
| Mr. Harris | 75 | 109.24% | \$ 439,373 |
| Mr. Woods | 75 | 84.96% | \$ 360,470 |

* As discussed above, Mr. Preston was guaranteed a fixed cash bonus for 2011 upon his recruitment to the Company.

** Upon his retirement from the Company, Mr. Simpson forfeited any annual cash bonus for 2011.

The MD&C Committee believes that the 2011 financial performance measures were goals that appropriately drove behaviors to create performance and results, in particular focusing on generating profitable revenue, cost cutting and cost control, and making the best use of our assets. When setting threshold, target and maximum performance measures each year, the MD&C Committee looks to the Company's historical results of operations and analyses and forecasts for the coming year. Specifically, the MD&C Committee considers expected revenue based on analyses of pricing and volume trends, as affected by operational and general economic factors; expected wage, maintenance, fuel and other operational costs; and expected selling and administrative costs. Based on this information, in light of general economic conditions and indicators in early 2011 and the Company's focus on growing revenue, the MD&C Committee determined that the target performance under the annual bonus plan for the income from operations excluding depreciation and amortization measure should be increased as compared to the prior year's target and actual performance and that target performance under the income from operations margin measure should be increased as compared to the prior year's target and on par with the prior year's actual performance. The MD&C Committee discussed the continued effects of the recessionary environment and the impact that the Company's transformational strategy was having on the Company's results of operations and the challenges that the Company was facing in 2011, but determined the improvement in performance targeted by these performance measures was reasonable and appropriate for 2011. The MD&C Committee acknowledged the Company's success reaching the pricing improvement gate of 3.0% in 2010 as a result of focused efforts on our pricing programs, but also acknowledged the risk that pricing improvement can pose to customer retention if not balanced, especially in a weak economy. Accordingly, the MD&C Committee determined that a slightly reduced pricing improvement target of 2.6% was reasonable and appropriate for 2011.

Long-Term Equity Incentives — Our equity awards are designed to hold individuals accountable for long-term decisions by rewarding the success of those decisions. The MD&C Committee continuously evaluates the components of its programs. In determining which forms of equity compensation are appropriate, the MD&C Committee considers whether the awards granted are achieving their purpose; the competitive market; and accounting, tax or other regulatory issues, among others. In determining the appropriate awards for the named executives' 2011 annual long-term incentive grant, the MD&C Committee decided to grant both performance share units that use ROIC to focus on improved asset utilization and stock options that focus on increasing the market value of our stock. In 2011, the MD&C Committee increased the weighting of stock options in our long-term incentive plan awards to 70% stock options and 30% performance share units in order to better align the Company with equity compensation practices of growth-oriented companies and to motivate our executives to aggressively focus on growth. Before determining the actual number of performance share units and stock options that were granted to each of the named executives in 2011, the MD&C Committee established a target dollar amount value for each individual's annual total long-term equity incentive award. The values chosen were based primarily on the comparison information for the competitive market, including an analysis of the named executives' responsibility for meeting the Company's strategic objectives. Additionally, our Chief Executive Officer and President proposed to the MD&C Committee that members of the senior leadership team, not

including himself, receive a one-time “transformational award” of long-term equity to reward senior leadership for undertaking the Company’s new strategic initiatives, to encourage key employees to lead a change in Company-wide culture, and to retain key employees as the Company undergoes its transformation. Accordingly, the MD&C Committee approved a one-time additional award to the named executives, other than Mr. Steiner, equal to 10% of the dollar value of the named executive’s annual long-term equity incentive award. This transformational award was made up of stock options and performance share units using the same terms as the annual long-term equity incentive grant.

| <u>Named Executive Officer</u> | <u>Dollar Values of Annual Long-Term Equity Incentives Set by the Committee (at Target)</u> | <u>Dollar Values of Additional Transformational Award Set by the Committee (at Target)</u> |
|--------------------------------|---|--|
| Mr. Steiner | \$5,100,000 | N/A |
| Mr. Preston* | N/A | N/A |
| Mr. Simpson | \$1,157,360 | \$115,736 |
| Mr. Trevathan | \$ 867,000 | \$ 86,700 |
| Mr. Harris | \$ 867,000 | \$ 86,700 |
| Mr. Woods | \$ 867,000 | \$ 86,700 |

* Mr. Preston was not yet employed by the Company at the time of the annual long-term equity incentive grants.

Performance Share Units

- *Named executives were granted new performance share units with a three-year performance period ending December 31, 2013, which may be earned based on the achievement of a ROIC goal.*
- *Named executive officers earned 86.99% of the performance share units that were granted in 2009 with the three-year performance period ended December 31, 2011; based on actual performance against goals described further below.*

Performance share units are granted to our named executive officers annually to align compensation with the achievement of our long-term financial goals and to build stock ownership. Performance share units provide an immediate retention value to the Company because there is unvested potential value at the date of grant. The number of performance share units granted to our named executive officers corresponds to an equal number of shares of Common Stock. At the end of the three-year performance period for each grant, the Company will deliver a number of shares ranging from 0% to 200% of the initial number of units granted, depending on the Company’s three-year performance against a pre-established ROIC target and subject to the general payout and forfeiture provisions. ROIC in our plan is defined generally as net operating profit after taxes divided by capital. Capital is comprised of long-term debt, noncontrolling interests and stockholders’ equity, less cash. ROIC is an indicator of our ability to generate returns for our stockholders. We believe that earnings growth is important and an appropriate measure for our annual bonuses. However, creating value over time is also important, and we therefore chose the three-year performance period for our long-term incentive compensation. We believe that using a three-year average of ROIC incentivizes our named executive officers to ensure the strategic direction of the Company is being followed and forces them to balance the short-term incentives awarded for growth with the long-term incentives awarded for value generated.

The MD&C Committee determined the number of units that were granted to each of the named executives in 2011 by taking the targeted dollar amounts established for total long-term equity incentives (set forth in the table above) and multiplying by 30%. Those values were then divided by the average of the high and low price of our Common Stock over the 30 trading days preceding the MD&C Committee meeting at which the grants were

approved to determine the target number of performance share units granted. The number of performance share units granted, including the transformational award, are shown in the table below:

| <u>Named Executive Officer</u> | <u>Number of Performance Share Units</u> |
|--------------------------------|--|
| Mr. Steiner | 40,263 |
| Mr. Preston* | N/A |
| Mr. Simpson** | 10,051 |
| Mr. Trevathan | 7,529 |
| Mr. Harris | 7,529 |
| Mr. Woods | 7,529 |

* Mr. Preston was not yet employed by the Company at the time that the 2011 performance share units were granted.

** Payout on performance share units granted to Mr. Simpson will be based on actual performance for the three-year performance period and will be prorated for his length of service before retirement.

The table below shows the required achievement of the ROIC performance measure and the corresponding potential payouts under our performance share units granted in 2011:

| | <u>Threshold</u> | | <u>Target</u> | | <u>Maximum</u> | |
|-----------------------|--------------------|---------------|--------------------|---------------|--------------------|---------------|
| | <u>Performance</u> | <u>Payout</u> | <u>Performance</u> | <u>Payout</u> | <u>Performance</u> | <u>Payout</u> |
| ROIC | 15.1% | 60% | 17.8% | 100% | 21.4% | 200% |

The threshold, target and maximum measures are determined based on an analysis of historical performance and current projections and trends. If actual performance falls between target and either threshold or maximum levels, then the number of performance share units earned will be interpolated between the target performance amount and either the threshold or maximum performance amount, as applicable. The MD&C Committee uses this analysis and modeling of different scenarios related to items that affect the Company’s performance such as yield, volumes and capital to set the performance measures. As with the consideration of targets for the annual bonus, the MD&C Committee carefully considered several material factors affecting the Company for 2011 and beyond, including the continued impact of the recessionary economy and the Company’s transformational strategy and economic indicators for future periods. Given these factors, the MD&C Committee determined that the target for ROIC for the 2011 award should be a measured and reasonable improvement from 2010 target ROIC.

The table below shows the performance measures, the achievement of those measures and the corresponding payouts for the additional performance share units that have been granted since 2008:

| | <u>ROIC</u> | | | | <u>EPS*</u> | | | | <u>Award Earned</u> |
|--|------------------|---------------|----------------|---------------|------------------|---------------|----------------|---------------|---|
| | <u>Threshold</u> | <u>Target</u> | <u>Maximum</u> | <u>Actual</u> | <u>Threshold</u> | <u>Target</u> | <u>Maximum</u> | <u>Actual</u> | |
| 2008 PSUs for period ended 12/31/10 | 17.6% | 19.6% | 23.5% | 17.1% | \$7.15 | \$7.44 | \$8.60 | \$6.29 | Threshold criteria was not attained, and awards expired without vesting |
| 2009 PSUs for period ended 12/31/11 ** | 15.6% | 17.3% | 20.8% | 16.7% | — | — | — | — | Units earned a 86.99% payout in shares of Common Stock issued in 2/12 |
| 2010 PSUs for period ended 12/31/12 | 15.8% | 17.6% | 21.1% | — | — | — | — | — | Pending completion of performance period |

* Earnings per share is based on the cumulative measure over the three-year performance period.

** Actual results set forth in the table are adjusted as described in the following paragraph.

Similar to the annual cash bonus performance metric calculations, the MD&C Committee has discretion to make adjustments to the ROIC calculation for unusual or otherwise non-operational matters that it believes do not accurately reflect results of operations expected from management for bonus purposes. In February 2012, the MD&C Committee approved adjustments to the calculation of results under the 2009 awards that had a performance period ended December 31, 2011. Net operating profit after taxes used in the calculation of results was adjusted to 1) include the effects of impairment charges resulting from the abandonment of licensed software and a cash litigation settlement received in connection with litigation pertaining to such software; and 2) exclude the effects of: (i) revisions of estimates associated with remedial liabilities; (ii) changes in ten-year Treasury rates, which are used to discount remediation reserves; (iii) withdrawal from underfunded multiemployer pension plans and labor disruption costs; (iv) charges related to the acquisition and integration of the acquired Oakleaf business; and (v) benefits from investments in low-income housing and a refined coal facility on tax rates. Capital used in the calculation of results was adjusted to exclude the impact of: (i) investments in low-income housing and a refined coal facility; (ii) the purchase price for Oakleaf, less goodwill and (iii) certain investments by our Wheelabrator subsidiary. Additionally, stockholders' equity used in the calculation of capital excludes the impact of prior year tax audit settlements.

Adjustments are made to ensure that rewards are aligned with the right business decisions and are not influenced by potential short-term gain or impact on bonuses. Adjusting for certain items, like those discussed herein, avoids creating incentives for individuals to fail to take actions for the longer-term good of the Company in order to meet short-term goals. The aggregate impact of the adjustments mentioned above resulted in increasing the payout percentage on performance shares units from 71.4% to 86.99%.

Stock Options — The MD&C Committee believes use of stock options is appropriate to support the growth element of the Company's strategy. The grant of options made to the named executive officers in the first quarter of 2011 in connection with the annual grant of long-term equity awards was based on the targeted dollar amounts established for total long-term equity incentives (set forth in the table above) and multiplied by 70%. The actual number of stock options granted was determined by assigning a value to the options using an option pricing model, and dividing the dollar value of compensation by the value of each option. The resulting number of stock options, including the transformational award, are shown in the table below:

| <u>Named Executive Officer</u> | <u>Number of Options</u> |
|--------------------------------|--------------------------|
| Mr. Steiner | 583,333 |
| Mr. Preston* | 184,584 |
| Mr. Simpson | 145,616 |
| Mr. Trevathan | 109,084 |
| Mr. Trevathan** | 150,000 |
| Mr. Harris | 109,084 |
| Mr. Woods | 109,084 |

* Initial grant of stock options received by Mr. Preston when he joined the Company, based on a target compensation value of \$1 million.

** Additional grant received by Mr. Trevathan upon his June 2011 promotion, based on a target compensation value of \$964,500.

The stock options will vest in 25% increments on the first two anniversaries of the date of grant and the remaining 50% will vest on the third anniversary. The exercise price of the options is the average of the high and low market price of our Common Stock on the date of grant, and the options have a term of 10 years. See the Grant of Plan-Based Awards in 2011 table below for specific exercise prices. We account for our employee stock options under the fair value method of accounting using a Black-Scholes methodology to measure stock option expense at the date of grant. The fair value of the stock options at the date of grant is amortized to expense over the vesting period.

Other Compensation Policies and Practices

Stock Ownership Requirements — All of our named executive officers are subject to stock ownership guidelines. We instituted stock ownership guidelines because we believe that ownership of Company stock demonstrates a commitment to, and confidence in, the Company’s long-term prospects and further aligns employees’ interests with those of our stockholders. We believe that the requirement that these individuals maintain a portion of their individual wealth in the form of Company stock deters actions that would not benefit stockholders generally. Although there is no deadline set for executives to reach their ownership requirements, the guidelines contain a holding requirement. Until the individual’s ownership requirement is achieved, Senior Vice Presidents and above are required to retain 100% of all net shares acquired through the Company’s long-term incentive plans and Vice Presidents are required to retain at least 50% of such net shares. The requisite stock ownership level must thereafter be retained throughout the officer’s employment with the Company. Additionally, the stock ownership guidelines generally require Senior Vice Presidents and above to hold all of their net shares and Vice Presidents to hold 50% of their net shares for at least one year after such shares are acquired, even if required ownership levels have already been achieved. Our MD&C Committee believes these holding periods discourage these individuals from taking actions in an effort to gain from short-term or otherwise fleeting increases in the market value of our stock.

The MD&C Committee regularly reviews its ownership guidelines to ensure that the appropriate share ownership requirements are in place, and the guidelines were last increased in late 2010. The stock ownership guidelines vary dependent on the individual’s title and are expressed as a fixed number of shares. Ownership requirements range from approximately three to five times the named executive’s 2011 base salary. Shares owned outright, deferred stock units, and phantom stock held in the 401(k) plan and in the Deferral Plan count toward meeting the targeted ownership requirements. Restricted stock shares, restricted stock units and performance share units, if any, do not count toward meeting the requirement until they are vested or earned. The following table outlines the ownership requirements for the named executive officers currently serving:

| <u>Named Executive Officer</u> | <u>Ownership Requirement (number of shares)</u> | <u>Attainment as of 12/31/2011</u> |
|--------------------------------|---|--|
| Mr. Steiner | 165,000 | 284% |
| Mr. Preston | 48,000 | 0% |
| Mr. Trevathan | 48,000 | 228% |
| Mr. Harris | 48,000 | 63% |
| Mr. Woods | 48,000 | 148% |

The Nominating and Governance Committee also establishes ownership guidelines for the independent directors and performs regular reviews to ensure all independent directors are in compliance.

Policy Limiting Severance Benefits — The MD&C Committee has approved an Executive Officer Severance Policy that generally provides that the Company may not enter into new severance arrangements with its executive officers, as defined in the federal securities laws, that provide for benefits, less the value of vested equity awards and benefits provided to employees generally, in an amount that exceeds 2.99 times the executive officer’s then current base salary and target bonus, unless such future severance arrangement receives stockholder approval. The policy applies to all of our named executive officers.

Policy Limiting Death Benefits and Gross-up Payments — The Company has adopted a “Policy Limiting Certain Compensation Practices,” which generally provides that the Company will not enter into new compensation arrangements that would obligate the Company to pay a death benefit or gross up-payment to an executive officer unless such arrangement receives stockholder approval. The policy is subject to certain exceptions, including benefits generally available to management-level employees and any payment in reasonable settlement of a legal claim. Additionally, “Death Benefits” under the policy does not include deferred compensation, retirement benefits or accelerated vesting or continuation of equity-based awards pursuant to generally-applicable equity award plan provisions.

Insider Trading — The Company maintains an insider trading policy that prohibits executive officers from engaging in most transactions involving the Company’s Common Stock during periods, determined by the

Company, that those executives are most likely to be aware of material, non-public information. Executive officers must clear all of their transactions in our Common Stock with the Company's General Counsel's office to ensure they are not transacting in our securities during a time that they may have material, non-public information. Additionally, it is our policy that executive officers are not permitted to engage in transactions that reduce or cancel the risk of an investment in our Common Stock, such as puts, calls and other exchange-traded derivatives, or hedging activities that allow a holder to own a covered security without the full risks and rewards of ownership.

Executive Compensation

We are required to present compensation information in the tabular format prescribed by the SEC. This format, including the tables' column headings, may be different from the way we describe or consider elements and components of compensation internally. The Compensation Discussion and Analysis contains a discussion that should be read in conjunction with these tables to gain a complete understanding of our executive compensation philosophy, programs and decisions.

Summary Compensation Table

| <u>Name and Principal Position</u> | <u>Year</u> | <u>Salary (\$)</u> | <u>Bonus (\$)</u> | <u>Stock Awards (\$)(1)</u> | <u>Option Awards (\$)(2)</u> | <u>Non-Equity Incentive Plan Compensation (\$)(3)</u> | <u>All Other Compensation (\$)(4)</u> | <u>Total (\$)</u> |
|---|-------------|------------------------|-----------------------|-------------------------------------|--------------------------------------|---|---|-----------------------|
| David P. Steiner President and Chief Executive Officer | 2011 | 1,120,625 | — | 1,497,180 | 3,453,331 | 1,095,356 | 269,921 | 7,436,413 |
| | 2010 | 1,073,077 | — | 2,331,306 | 1,943,017 | 1,407,514 | 206,509 | 6,961,423 |
| | 2009 | 1,116,346 | — | 3,069,956 | — | 1,035,978 | 258,524 | 5,480,804 |
| Steven C. Preston(5) Executive Vice President, Finance, Recycling and Energy Services | 2011 | 214,885 | 510,000 | — | 913,691 | — | — | 1,638,576 |
| James E. Trevathan Executive Vice President, Growth, Innovation and Field Support | 2011 | 566,298 | — | 279,966 | 1,518,777 | 360,845 | 12,325 | 2,738,211 |
| | 2010 | 566,298 | — | 363,835 | 303,227 | 487,875 | 12,325 | 1,733,560 |
| | 2009 | 566,298 | — | 499,973 | — | 403,374 | 12,575 | 1,482,220 |
| Jeff M. Harris Senior Vice President — Midwest Group | 2011 | 536,278 | — | 279,966 | 645,777 | 439,373 | 57,371 | 1,958,765 |
| | 2010 | 536,278 | — | 363,835 | 303,227 | 711,265 | 42,553 | 1,957,158 |
| | 2009 | 536,278 | — | 499,973 | — | 381,991 | 33,194 | 1,451,436 |
| Duane C. Woods Senior Vice President — Western Group | 2011 | 565,710 | — | 279,966 | 645,777 | 360,470 | 12,322 | 1,864,245 |
| | 2010 | 565,710 | — | 363,835 | 303,227 | 439,860 | 12,322 | 1,684,954 |
| | 2009 | 565,710 | — | 499,973 | — | 402,955 | 15,263 | 1,483,901 |
| Robert G. Simpson(6) Former Senior Vice President & Chief Financial Officer | 2011 | 415,671 | — | 373,746 | 862,047 | — | 22,944 | 1,674,408 |
| | 2010 | 518,781 | — | 587,281 | 489,458 | 502,953 | 38,356 | 2,136,829 |
| | 2009 | 541,022 | — | 845,824 | — | 371,098 | 31,655 | 1,789,599 |

(1) Amounts in this column represent the grant date fair value of performance share units granted in the applicable year, in accordance with the Financial Accounting Standards Board Accounting Standards Codification ("ASC") Topic 718. The grant date fair value of performance share units is calculated using the average of the high and low market price of our Common Stock on the date of grant.

The table below shows the aggregate grant date fair value of performance share units if we assumed the highest level of performance criteria will be achieved and the maximum amounts will be earned.

| | <u>Year</u> | <u>Aggregate Grant Date Fair Value of Award Assuming Highest Level of Performance Achieved (\$)</u> |
|---------------------|-------------|---|
| Mr. Steiner | 2011 | 2,994,360 |
| | 2010 | 4,662,612 |
| | 2009 | 6,139,912 |
| Mr. Preston | 2011 | — |
| Mr. Trevathan | 2011 | 559,932 |
| | 2010 | 727,670 |
| | 2009 | 999,946 |
| Mr. Harris | 2011 | 559,932 |
| | 2010 | 727,670 |
| | 2009 | 999,946 |
| Mr. Woods | 2011 | 559,932 |
| | 2010 | 727,670 |
| | 2009 | 999,946 |
| Mr. Simpson | 2011 | 747,492 |
| | 2010 | 1,174,562 |
| | 2009 | 1,691,648 |

- (2) Amounts in this column represent the grant date fair value of stock options granted in 2011, in accordance with ASC Topic 718. The grant date fair value of the options was estimated using the Black-Scholes option pricing model. The assumptions made in determining the grant date fair values of options are disclosed in Note 16 in the Notes to the Consolidated Financial Statements in our 2011 Annual Report on Form 10-K.
- (3) Amounts in this column represent cash bonuses earned and paid based on the achievement of performance goals pursuant to our Annual Incentive Plan.
- (4) The amounts included in “All Other Compensation” for 2011 are shown below (in dollars):

| | <u>Personal Use of Company Aircraft</u> | <u>401(k) Matching Contributions</u> | <u>Deferral Plan Matching Contributions</u> | <u>Life Insurance Premiums</u> |
|---------------------|---|--|---|--|
| Mr. Steiner | 153,634 | 11,025 | 102,741 | 2,521 |
| Mr. Preston | — | — | — | — |
| Mr. Trevathan | — | 11,025 | — | 1,300 |
| Mr. Harris | — | 11,025 | 45,115 | 1,231 |
| Mr. Woods | — | 11,025 | — | 1,297 |
| Mr. Simpson | — | 11,025 | 11,004 | 915 |

Mr. Steiner is required by us to use the Company aircraft for all travel, whether for personal or business purposes. We calculated this amount based on the incremental cost to us, which includes fuel, crew travel expenses, on-board catering, landing fees, trip related hangar/parking costs and other variable costs. We own or operate our aircraft primarily for business use; therefore, we do not include the fixed costs associated with the ownership or operation such as pilots’ salaries, purchase costs and non-trip related maintenance.

- (5) The Company began compensating Mr. Preston as the President of Oakleaf Global Holdings following the acquisition of Oakleaf in July 2011. Mr. Preston was elected Executive Vice President — Finance, Recycling and Energy Services of the Company effective October 1, 2011. The amount in the “bonus” column reflects the guaranteed cash bonus for 2011 that was negotiated at the time that Mr. Preston accepted his current position.
- (6) Upon Mr. Simpson’s retirement from the Company on September 30, 2011, he forfeited any cash bonus for 2011 under the Annual Incentive Plan. Additionally, the performance share units that were granted to him in March 2011, March 2010 and March 2009 were prorated based on the portion of the applicable performance period that he was employed by the Company. Payouts on the prorated performance share units, if any, will be made at the end of the corresponding performance period based on actual performance of the Company. The stock options Mr. Simpson received on March 9, 2010 and March 9, 2011 will continue to vest in accordance with the vesting schedule set forth in stock option grants; however, such vested options will remain exercisable only for 36 months from his date of retirement.

Grant of Plan-Based Awards in 2011

| Name | Grant Date | Estimated Possible Payouts Under Non-Equity Incentive Plan Awards (1) | | | Estimated Future Payouts Under Equity Incentive Plan Awards (2) | | | All other Option Awards: Number of Securities Underlying Options (#)(3) | Exercise or Base Price of Option Awards (\$/sh)(4) | Closing Market Price on Date of Grant (\$) | Grant Date Fair Value of Stock and Option Awards (\$)(5) |
|--------------------------------|------------|---|-------------|--------------|---|------------|-------------|---|--|--|--|
| | | Threshold (\$) | Target (\$) | Maximum (\$) | Threshold (#) | Target (#) | Maximum (#) | | | | |
| David P. Steiner | 03/09/11 | 902,482 | 1,289,260 | 2,578,520 | 24,158 | 40,263 | 80,526 | | | | 1,497,180 |
| | 03/09/11 | | | | | | | 583,333 | 37.185 | 37.35 | 3,453,331 |
| Steven C. Preston | | — | — | — | — | — | — | | | | — |
| | 10/04/11 | | | | | | | 184,584 | 31.28 | 31.99 | 913,691 |
| James E. Trevathan | 03/09/11 | 297,307 | 424,724 | 849,448 | 4,517 | 7,529 | 15,058 | | | | 279,966 |
| | 03/09/11 | | | | | | | 109,084 | 37.185 | 37.35 | 645,777 |
| | 07/05/11 | | | | | | | 150,000 | 37.585 | 37.62 | 873,000 |
| Jeff Harris | 03/09/11 | 281,546 | 402,209 | 804,418 | 4,517 | 7,529 | 15,058 | | | | 279,966 |
| | 03/09/11 | | | | | | | 109,084 | 37.185 | 37.35 | 645,777 |
| Duane C. Woods | 03/09/11 | 296,998 | 424,283 | 848,566 | 4,517 | 7,529 | 15,058 | | | | 279,966 |
| | 03/09/11 | | | | | | | 109,084 | 37.185 | 37.35 | 645,777 |
| Robert G. Simpson(6) | 03/09/11 | 322,250 | 460,357 | 920,714 | 6,031 | 10,051 | 20,102 | | | | 373,746 |
| | 03/09/11 | | | | | | | 145,616 | 37.185 | 37.35 | 862,047 |

- (1) Actual payouts of our 2011 cash bonuses pursuant to our Annual Incentive Plan are shown in the Summary Compensation Table under “Non-Equity Incentive Plan Compensation.” The named executives’ target and maximum bonuses are a percentage of base salary, provided for in their employment agreements. The threshold levels represent the bonus amounts that would have been payable if the minimum performance requirements were met for each performance measure. Please see “Compensation Discussion and Analysis — Named Executive’s 2011 Compensation Program and Results — Annual Cash Bonus” for additional information about these awards, including performance criteria.
- (2) Represents the number of shares of Common Stock potentially issuable based on the achievement of performance criteria under performance share unit awards granted under our 2009 Stock Incentive Plan. Please see “Compensation Discussion and Analysis — Named Executive’s 2011 Compensation Program and Results — Long-Term Equity Incentives — Performance Share Units” for additional information about these awards, including performance criteria. The performance period for these awards ends December 31, 2013. Performance share units earn dividend equivalents, which are paid out based on the number of shares actually earned, if any, at the end of the performance period.
- (3) Represents the number of shares of Common Stock potentially issuable upon the exercise of options granted under our 2009 Stock Incentive Plan. Please see “Compensation Discussion and Analysis — Named Executive’s 2011 Compensation Program and Results — Long-Term Equity Incentives — Stock Options” for additional information

about these awards. The stock options will vest in 25% increments on the first two anniversaries of the date of grant and the remaining 50% will vest on the third anniversary. Although we consider all of our equity awards to be a form of incentive compensation because their value will increase as the market value of our Common Stock increases, only awards with performance criteria are considered “equity incentive plan awards” for SEC disclosure purposes. As a result, option awards are not included as “Equity Incentive Plan Awards” in the table above or the Outstanding Equity Awards at December 31, 2011 table.

- (4) The exercise price represents the average of the high and low market price on the date of the grant, in accordance with our 2009 Stock Incentive Plan.
- (5) These amounts represent grant date fair value of the awards as calculated under ASC Topic 718. Please see footnotes (1) and (2) to the Summary Compensation Table above for additional information.
- (6) Upon Mr. Simpson’s retirement from the Company on September 30, 2011, he forfeited any cash bonus for 2011 under the Annual Incentive Plan. Additionally, his performance share units that were granted on March 9, 2011 were prorated based on the portion of the three-year performance period that he was employed by the Company; accordingly, he now has 2,504 performance share units with a performance period ending December 31, 2013. Payouts on the prorated performance share units, if any, will be made at the end of the performance period based on actual performance of the Company. The stock options Mr. Simpson received on March 9, 2011 will continue to vest in accordance with the vesting schedule set forth in stock option grant; however, such vested options will remain exercisable only for 36 months from his date of retirement.

Outstanding Equity Awards at December 31, 2011

| Name | Option Awards | | | | Stock Awards(1) | |
|--------------------|--|---|----------------------------|------------------------|--|---|
| | Number of Securities Underlying Unexercised Options Exercisable (#)(2) | Number of Securities Underlying Unexercised Options Unexercisable (#) | Option Exercise Price (\$) | Option Expiration Date | Equity Incentive Plan Awards: Number of Unearned Shares, Units or Other Rights That Have Not Vested (#)(6) | Equity Incentive Plan Awards: Market or Payout Value of Unearned Shares, Units or Other Rights That Have Not Vested |
| David P. Steiner | — | 583,333(3) | 37.185 | 03/09/2021 | 109,875 | \$3,594,011 |
| | 82,752 | 248,256(4) | 33.49 | 03/09/2020 | — | — |
| | — | 24,922(5) | 38.205 | 03/06/2013 | — | — |
| | 90,000 | — | 29.24 | 03/04/2014 | — | — |
| | 335,000 | — | 21.08 | 04/03/2013 | — | — |
| | 56,593 | — | 19.61 | 03/06/2013 | — | — |
| | 135,000 | — | 27.88 | 03/07/2012 | — | — |
| Steven C. Preston | — | 184,584(3) | 31.28 | 10/04/2021 | — | — |
| James E. Trevathan | — | 150,000(3) | 37.585 | 07/05/2021 | 18,393 | \$ 601,635 |
| | — | 109,084(3) | 37.185 | 03/09/2021 | — | — |
| | 12,914 | 38,743(4) | 33.49 | 03/09/2020 | — | — |
| | 20,000 | — | 29.23 | 07/19/2014 | — | — |
| | 50,000 | — | 29.24 | 03/04/2014 | — | — |
| | 120,000 | — | 19.61 | 03/06/2013 | — | — |
| | 65,000 | — | 27.88 | 03/07/2012 | — | — |
| Jeff M. Harris | — | 109,084(3) | 37.185 | 03/09/2021 | 18,393 | \$ 601,635 |
| | 12,914 | 38,743(4) | 33.49 | 03/09/2020 | — | — |
| Duane C. Woods | — | 109,084(3) | 37.185 | 03/09/2021 | 18,393 | \$ 601,635 |
| | 12,914 | 38,743(4) | 33.49 | 03/09/2020 | — | — |
| | 50,000 | — | 28.45 | 06/03/2014 | — | — |
| | 20,000 | — | 29.24 | 03/04/2014 | — | — |
| | 18,000 | — | 19.61 | 03/06/2013 | — | — |
| Robert G. Simpson | — | 145,616(3) | 37.185 | 03/09/2021 | 12,712 | \$ 415,810 |
| | 20,845 | 62,538(4) | 33.49 | 03/09/2020 | — | — |
| | 33,000 | — | 27.60 | 05/13/2014 | — | — |
| | 42,000 | — | 29.24 | 03/04/2014 | — | — |

- (1) All amounts are as of December 31, 2011, and dollar values are based on the closing price of the Company's Common Stock on that date of \$32.71 and assume target performance criteria and target payout will be achieved.
- (2) Represents vested stock options granted (i) on March 9, 2010 pursuant to our 2009 Stock Incentive Plan and (ii) prior to 2005 pursuant to our 1993 Stock Incentive Plan, 2000 Stock Incentive Plan or 2004 Stock Incentive Plan (collectively, the "Prior Plans"). All of the Prior Plans have terminated, and no new awards are being granted pursuant to such plans.
- (3) Represents stock options granted on March 9, 2011 that vested 25% on the first anniversary of the date of grant. An additional 25% will vest on the second anniversary of the date of grant and 50% on the third anniversary of the date of grant.
- (4) Represents stock options granted on March 9, 2010 that vested 25% on the first and second anniversary of the date of grant. The remaining 50% will vest on the third anniversary of the date of grant.
- (5) Represents reload stock options that become exercisable once the market value of our Common Stock has increased by 25% over the option's exercise price.
- (6) Includes performance share units with three-year performance periods. Payouts on performance share units are made after the Company's financial results of operations for the entire performance period are reported, typically in mid to late February of the succeeding year. The performance share units for the performance period ended on December 31, 2011 are not included in the table as they were earned as of December 31, 2011, although they were not paid until the Company's financial results of operations for the entire performance period were reported on February 16, 2012; instead, such performance share units are included in the Option Exercises and Stock Vested in 2011 table below. The following number of performance share units have a performance period ending December 31, 2012: Mr. Steiner — 69,612; Mr. Trevathan — 10,864; Mr. Harris — 10,864; Mr. Woods — 10,864; and Mr. Simpson — 10,208. The following number of performance share units have a performance period ending on December 31, 2013: Mr. Steiner — 40,263; Mr. Trevathan — 7,529; Mr. Harris — 7,529; Mr. Woods — 7,529; and Mr. Simpson — 2,504. In this paragraph and in the table, the number of Mr. Simpson's performance share units reflects that such awards were prorated upon his retirement based on the portion of the applicable performance period that he was employed by the Company.

Option Exercises and Stock Vested in 2011

| | Option Awards | | Stock Awards(1) | |
|--------------------|---|---------------------------------|--|--------------------------------|
| | Number of Shares Acquired on Exercise (#) | Value Realized on Exercise (\$) | Number of Shares Acquired on Vesting (#) | Value Realized on Vesting (\$) |
| David P. Steiner | — | — | 117,879 | 4,060,342 |
| Steven C. Preston | — | — | — | — |
| James E. Trevathan | — | — | 19,198 | 661,275 |
| Jeff M. Harris | — | — | 19,198 | 661,275 |
| Duane C. Woods | — | — | 19,198 | 661,275 |
| Robert G. Simpson | 111,768(2) | 1,198,527 | 29,749 | 1,024,704 |

- (1) Includes performance share units granted in 2009 with a performance period ended December 31, 2011 that were paid out on February 16, 2012 based on the average of the high and low market price of the Company's Common Stock.
- (2) We withheld shares in payment of the exercise price and minimum statutory tax withholding from Mr. Simpson's exercise of non-qualified stock options. Mr. Simpson received 24,126 net shares in this transaction.

Nonqualified Deferred Compensation in 2011

| Name | Executive Contributions in Last Fiscal Year \$(1) | Registrant Contributions in Last Fiscal Year \$(2) | Aggregate Earnings in Last Fiscal Year \$(3) | Aggregate Withdrawals/ Distributions \$(4) | Aggregate Balance at Last Fiscal Year End \$(1) |
|------------------------------|---|--|--|---|---|
| David P. Steiner | 308,576 | 102,741 | 5,642 | 0 | 2,518,669 |
| Steven C. Preston | — | — | — | — | — |
| James E. Trevathan | 0 | 0 | 69,734 | 0 | 2,692,485 |
| Jeff M. Harris | 91,167 | 45,115 | 49,656 | 0 | 974,737 |
| Duane C. Woods | 0 | 0 | (11,886) | 0 | 1,625,083 |
| Robert G. Simpson | 24,940 | 11,004 | 13,693 | 0 | 521,874 |

- (1) Contributions are under the Company’s Deferral Plan as described in “Compensation Discussion and Analysis — Overview of Elements of Our 2011 Compensation Program — Deferral Plan.” In this Proxy Statement as well as in previous years, we include executive contributions to the Deferral Plan in the Base Salary column of the Summary Compensation Table. Aggregate Balance at Last Fiscal Year End includes the following aggregate amounts of the named executives’ base salaries that were included in Base Salary in the Summary Compensation Table in 2008-2010: Mr. Steiner — \$643,154; Mr. Trevathan — \$140,526; Mr. Harris — \$255,914; Mr. Woods — \$58,000; and Mr. Simpson — \$94,602.
- (2) Company contributions to the executives’ Deferral Plan accounts are included in All Other Compensation, but not Base Salary, in the Summary Compensation Table.
- (3) Earnings on these accounts are not included in any other amounts in the tables included in this Proxy Statement, as the amounts of the named executives’ earnings represent the general market gains (or losses) on investments, rather than amounts or rates set by the Company for the benefit of the named executives.
- (4) Accounts are distributed as either a lump sum payment or in annual installments (i) when the employee has reached at least 65 years of age or (ii) at a future date that occurs after termination of employment. Special circumstances may allow for a modified distribution in the event of the employee’s death, an unforeseen emergency, or upon a change-in-control of the Company. In the event of death, distribution will be made to the designated beneficiary in the form previously elected by the executive. In the event of an unforeseen emergency, the plan administrator may allow an early payment in the amount required to satisfy the emergency. All participants are immediately 100% vested in all of their contributions, Company matching contributions, and gains and/or losses related to their investment choices.

Potential Payments Upon Termination or Change-in-Control

The payments our named executives receive upon termination or change-in-control are based on provisions included in employment agreements and individual equity award agreements. We enter into employment agreements with our named executive officers because they encourage continuity of our leadership team, which is particularly valuable as leadership manages the Company through the change needed to successfully implement our transformational business strategy. Employment agreements also provide a form of protection for the Company through restrictive covenant provisions; each of the agreements contains post-termination restrictive covenants, including a covenant not to compete, non-solicitation covenants, and a non-disparagement covenant, each of which lasts for two years after termination. They also provide the individual with comfort that he will be treated fairly in the event of a termination not for cause or under a change-in-control situation. The change-in-control provision included in each named executive officer’s agreement requires a double trigger in order to receive any payment in the event of a change-in-control situation. First, a change-in-control must occur, and second, the individual must terminate his employment for good reason or the Company must terminate his employment without cause within six months prior to or two years following the change-in-control event. We believe providing change-in-control protection encourages our named executives to pursue and facilitate change-in-control transactions that are in the best interests of stockholders while not granting executives an undeserved windfall.

Employment agreements entered into with named executive officers after February 2004 include (a) a requirement that the individual execute a general release prior to receiving post-termination benefits and (b) a clawback feature that allows for the suspension and refund of termination benefits for subsequently discovered cause. These provisions are applicable to Mr. Simpson and Mr. Woods, whose agreements were entered into in October 2004, Mr. Harris, whose agreement was entered into in November 2006, and Mr. Preston, whose agreement was entered into in October 2011. The clawback feature in the agreements generally allows the Company to cancel any remaining payments due and obligates the named executive to refund to the Company severance payments already made if, within one year of termination of employment of the named executive by the Company for any reason other than for cause, the Company determines that the named executive could have been terminated for cause.

Our current form of award agreements for equity awards also contain provisions regarding termination and change-in-control. Our stock option awards are also subject to double trigger vesting in the event of a change-in-control situation. The performance share unit award agreements provide that, in the event of a change-in-control and regardless of termination, performance share units will be paid out in cash on a prorated basis based on actual results achieved through the end of the fiscal quarter prior to a change-in-control. Thereafter, the executive would be compensated for the lost opportunity from the date of the change-in-control to the end of the original performance period by receiving a replacement award of restricted stock units in the successor entity, provided that the successor entity is publicly traded. If the successor is not publicly traded, the executive will be entitled to a replacement award of cash. In either case, the replacement award would not vest until the end of the original performance share unit performance period. However, if the employee is thereafter involuntarily terminated other than for cause within the change-in-control window referenced, he would vest in full in the replacement award.

Our current equity award agreements also include (a) a requirement that, in order to be eligible to vest in any portion of the award, the employee must enter into an agreement containing restrictive covenants applicable to the employee's behavior following termination and (b) compensation clawback provisions. Such clawback provisions provide that, if the MD&C Committee determines that an employee either engaged in or benefited from misconduct, then the employee will refund any amounts received under the equity award agreements. Misconduct generally includes any act or failure to act that caused or was intended to cause a violation of the Company's policies, generally accepted accounting principles or applicable laws and that materially increased the value of the equity award. Further, our MD&C Committee has adopted a clawback policy applicable to our annual incentive plan awards that is designed to recoup annual cash incentive payments when the recipient's personal misconduct results in a restatement or otherwise affects the payout calculations for the awards. Clawback terms applicable to our incentive awards allow recovery within the earlier to occur of one year after discovery of misconduct and the second anniversary of the employee's termination of employment.

The terms "Cause," "Good Reason," and "Change-in-Control" as used in the table below are defined in the executives' employment agreements and/or the applicable equity award agreement and have the meanings generally described below. You should refer to the individual agreements for the actual definitions.

"Cause" generally means the named executive has:

- deliberately refused to perform his duties;
- breached his duty of loyalty to the Company;
- been convicted of a felony;
- intentionally and materially harmed the Company; or
- breached the covenants contained in his agreement.

"Good Reason" generally means that, without the named executive's consent:

- his duties or responsibilities have been substantially changed;
- he has been removed from his position;

- the Company has breached his employment agreement;
- any successor to the Company has not assumed the obligations under his employment agreement; or
- he has been reassigned to a location more than 50 miles away.

Additionally, with respect to Mr. Preston only, Good Reason also includes the event that he no longer reports directly to the current Chief Executive Officer, David P. Steiner.

“Change-in-Control” generally means that:

- at least 25% of the Company’s Common Stock has been acquired by one person or persons acting as a group;
- the majority of the Board of Directors consists of individuals other than those serving as of the date of the named executive’s employment agreement or those that were not elected by at least two-thirds of those directors;
- there has been a merger of the Company in which at least 50% of the combined post-merger voting power of the surviving entity does not consist of the Company’s pre-merger voting power, or a merger to effect a recapitalization that resulted in a person or persons acting as a group acquired 25% or more of the Company’s voting securities; or
- the Company is liquidating or selling all or substantially all of its assets.

The following tables represent potential payouts to our named executives still serving the Company at year-end upon termination of employment in the circumstances indicated pursuant to the terms of their employment agreements and outstanding incentive awards. In the event a named executive is terminated for cause, he is entitled to any accrued but unpaid salary only. Please see the Non-Qualified Deferred Compensation table above for aggregate balances payable to the named executives under our Deferral Plan pursuant to the executive’s distribution election.

The payouts set forth below assume the triggering event indicated occurred on December 31, 2011, at which time the closing price of our Common Stock was \$32.71 per share. These payouts are determined for SEC disclosure purposes and are not necessarily indicative of the actual amounts the named executive would receive. Please note the following when reviewing the payouts set forth below:

- The compensation component set forth below for accelerated vesting of stock options is comprised of the unvested stock options granted in 2010 and 2011, which vest 25% on the first and second anniversary of the date of grant and 50% on the third anniversary of the date of grant. However, with the exception of Mr. Preston’s stock option award granted in October 2011, the exercise prices of the stock options granted to the named executives in 2010 and 2011 exceeded the closing price of our Common Stock on December 31, 2011. Accordingly, the options granted in 2010 and 2011, and the accelerated vesting of such options, had no value on December 31, 2011, except in the case of Mr. Preston.
- For purposes of calculating the payout of performance share unit awards outstanding at December 31, 2011, we have assumed that target performance was achieved; any actual performance share unit payouts will be based on actual performance of the Company during the performance period;
- For purposes of calculating the payout upon the “double trigger” of change-in-control and subsequent involuntary termination not for cause, the value of the performance share unit replacement award is equal to the number of performance share units that would be forfeited based on the prorated acceleration of the performance share units, multiplied by the closing price of our Common Stock on December 31, 2011;
- The payout for continuation of benefits is an estimate of the cost the Company would incur to continue those benefits.
- Waste Management’s practice is to provide all benefits eligible employees with life insurance that pays one times annual base salary upon death. The insurance benefit is a payment by an insurance company, not the Company, and is payable under the terms of the insurance policy.

Potential Consideration upon Termination of Employment:

David P. Steiner

| <u>Triggering Event</u> | <u>Compensation Component</u> | <u>Payout (\$)</u> |
|--|---|--------------------------|
| <i>Death or Disability</i> | <i>Severance Benefits</i> | |
| | • Accelerated vesting of stock options | 0 |
| | • Payment of performance share units (contingent on actual performance at end of performance period) | 3,594,011 |
| | • Two times base salary as of date of termination (payable in bi-weekly installments over a two-year period)(1) | 2,255,000 |
| | • Life insurance benefit paid by insurance company (in the case of death) | 1,100,000 |
| | Total | <u>6,949,011</u> |
| <i>Termination Without Cause by the Company or For Good Reason by the Employee</i> | <i>Severance Benefits</i> | |
| | • Two times base salary plus target annual cash bonus (one-half payable in lump sum; one-half payable in bi-weekly installments over a two-year period) | 4,848,250 |
| | • Continued coverage under health and welfare benefit plans for two years | 22,200 |
| | • Prorated payment of performance share units (contingent on actual performance at end of performance period) | 1,955,240 |
| | Total | <u>6,825,690</u> |
| <i>Termination Without Cause by the Company or For Good Reason by the Employee Six Months Prior to or Two Years Following a Change-in-Control (Double Trigger)</i> | <i>Severance Benefits</i> | |
| | • Three times base salary plus target annual cash bonus, paid in lump sum(1) | 7,272,375 |
| | • Continued coverage under health and welfare benefit plans for three years | 33,300 |
| | • Accelerated vesting of stock options | 0 |
| | • Prorated accelerated payment of performance share units | 1,955,240 |
| | • Accelerated payment of performance share units replacement grant | 1,638,771 |
| | • Prorated maximum annual cash bonus | 2,593,250 |
| | • Gross-up payment for any excise taxes(1) | 0 |
| | Total | <u>13,492,936</u> |

Steven C. Preston

| <u>Triggering Event</u> | <u>Compensation Component</u> | <u>Payout (\$)</u> |
|--|---|-------------------------|
| <i>Death or Disability</i> | Severance Benefits | |
| | • Accelerated vesting of stock options | 263,955 |
| | Total | <u><u>263,955</u></u> |
| <i>Termination Without Cause by the Company or For Good Reason by the Employee</i> | Severance Benefits | |
| | • Two times base salary plus target annual cash bonus (one-half payable in lump sum; one-half payable in bi-weekly installments over a two-year period) | 2,180,000 |
| | • Continued coverage under health and welfare benefit plans for two years | 22,200 |
| | Total | <u><u>2,202,200</u></u> |
| <i>Termination Without Cause by the Company or For Good Reason by the Employee Six Months Prior to or Two Years Following a Change-in-Control (Double Trigger)</i> | Severance Benefits | |
| | • Two times base salary plus target annual cash bonus (one-half payable in lump sum; one-half payable in bi-weekly installments over a two-year period) | 2,180,000 |
| | • Continued coverage under health and welfare benefit plans for two years | 22,200 |
| | • Accelerated vesting of stock options | 263,955 |
| | • Prorated maximum annual cash bonus | 510,000 |
| | Total | <u><u>2,976,155</u></u> |

James E. Trevathan

| <u>Triggering Event</u> | <u>Compensation Component</u> | <u>Payout (\$)</u> |
|--|---|-------------------------|
| <i>Death or Disability</i> | Severance Benefits | |
| | • Accelerated vesting of stock options | 0 |
| | • Payment of performance share units (contingent on actual performance at end of performance period) | 601,635 |
| | • Two times base salary as of the date of termination (payable in bi-weekly installments over a two-year period(1) | 1,132,596 |
| | • Life insurance benefit paid by insurance company (in the case of death) | 567,000 |
| | Total | <u>2,301,231</u> |
| <i>Termination Without Cause by the Company or For Good Reason by the Employee</i> | Severance Benefits | |
| | • Two times base salary plus target annual cash bonus (one-half payable in lump sum; one-half payable in bi-weekly installments over a two-year period) | 1,982,044 |
| | • Continued coverage under benefit plans for two years | |
| | • Health and welfare benefit plans | 22,200 |
| | • 401(k) contributions | 22,050 |
| | • Prorated payment of performance share units (contingent on actual performance at end of performance period) | 318,694 |
| | Total | <u>2,344,988</u> |
| <i>Termination Without Cause by the Company or For Good Reason by the Employee Six Months Prior to or Two Years Following a Change-in-Control (Double Trigger)</i> | Severance Benefits | |
| | • Two times base salary plus target annual cash bonus, paid in lump sum | 1,982,044 |
| | • Continued coverage under benefit plans for two years | |
| | • Health and welfare benefit plans | 22,200 |
| | • 401(k) contributions | 22,050 |
| | • Accelerated vesting of stock options | 0 |
| | • Prorated accelerated payment of performance share units | 318,694 |
| | • Accelerated payment of performance share units replacement grant | 282,941 |
| | • Prorated maximum annual cash bonus | 849,448 |
| | • Gross-up payment for any excise taxes(1) | 0 |
| | Total | <u>3,477,377</u> |

Jeff M. Harris

| <u>Triggering Event</u> | <u>Compensation Component</u> | <u>Payout (\$)</u> |
|--|---|-------------------------|
| <i>Death or Disability</i> | Severance Benefits | |
| | • Accelerated vesting of stock options | 0 |
| | • Payment of performance share units (contingent on actual performance at end of performance period) | 601,635 |
| | • Life insurance benefit paid by insurance company (in the case of death) | 537,000 |
| | Total | <u>1,138,635</u> |
| <i>Termination Without Cause by the Company or For Good Reason by the Employee</i> | Severance Benefits | |
| | • Two times base salary plus target annual cash bonus (one-half payable in lump sum; one-half payable in bi-weekly installments over a two-year period) | 1,876,974 |
| | • Continued coverage under health and welfare benefit plans for two years | 22,200 |
| | • Prorated payment of performance share units (contingent on actual performance at end of performance period) | 318,694 |
| | Total | <u>2,217,868</u> |
| <i>Termination Without Cause by the Company or For Good Reason by the Employee Six Months Prior to or Two Years Following a Change-in-Control (Double Trigger)</i> | Severance Benefits | |
| | • Three times base salary plus target annual cash bonus, paid in lump sum(1) | 2,815,461 |
| | • Continued coverage under health and welfare benefit plans for three years | 33,300 |
| | • Accelerated vesting of stock options | 0 |
| | • Prorated accelerated payment of performance share units | 318,694 |
| | • Accelerated payment of performance share units replacement grant | 282,941 |
| | • Prorated maximum annual cash bonus | 804,418 |
| | Total | <u>4,254,814</u> |

Duane C. Woods

| <u>Triggering Event</u> | <u>Compensation Component</u> | <u>Payout (\$)</u> |
|--|---|-------------------------|
| <i>Death or Disability</i> | Severance Benefits | |
| | • Accelerated vesting of stock options | 0 |
| | • Payment of performance share units (contingent on actual performance at end of performance period) | 601,635 |
| | • Life insurance benefit paid by insurance company (in the case of death) | 566,000 |
| | Total | <u>1,167,635</u> |
| <i>Termination Without Cause by the Company or For Good Reason by the Employee</i> | Severance Benefits | |
| | • Two times base salary plus target annual cash bonus (one-half payable in lump sum; one-half payable in bi-weekly installments over a two-year period) | 1,979,986 |
| | • Continued coverage under health and welfare benefit plans for two years | 22,200 |
| | • Prorated payment of performance share units (contingent on actual performance at end of performance period) | 318,694 |
| | Total | <u>2,320,880</u> |
| <i>Termination Without Cause by the Company or For Good Reason by the Employee Six Months Prior to or Two Years Following a Change-in-Control (Double Trigger)</i> | Severance Benefits | |
| | • Three times base salary plus target annual cash bonus, paid in lump sum(1) | 2,969,979 |
| | • Continued coverage under health and welfare benefit plans for three years | 33,300 |
| | • Accelerated vesting of stock options | 0 |
| | • Prorated accelerated payment of performance share units | 318,694 |
| | • Accelerated payment of performance share units replacement grant | 282,941 |
| | • Prorated maximum annual cash bonus, | 848,566 |
| | • Gross-up payment for any excise taxes(1) | 1,353,630 |
| Total | <u>5,807,110</u> | |

(1) In the past, such provisions have been included in certain named executives' employment agreements. However, the Company's compensation policy now provides that it will not enter into any future compensation arrangements that obligate the Company to provide increased payments in the event of death or to make tax gross up payments, subject to certain exceptions. Additionally, our Executive Officer Severance Policy generally provides that the Company may not enter into new severance arrangements with its executive officers that provide for benefits, less the value of vested equity awards and benefits provided to employees generally, in an amount that exceeds 2.99 times the executive officer's then current base salary and target bonus. For additional details, see "Compensation Discussion and Analysis — Other Compensation Policies and Practices."

With the exception of 75% of the 2011 stock option awards, 50% of the 2010 stock option awards, and the reload options, all of the named executives' stock options have vested in full. In the event of termination for cause, all options are immediately cancelled. Some of our named executive officers have provisions in their employment agreements that provide the executive with a longer period of time to exercise their vested stock options after termination of the executive's employment than is provided in the original stock option award

agreement. The employment agreement we entered into with Mr. Steiner gives him the ability to exercise all stock options granted before 2004 for (i) two years after termination of employment without cause or for good reason and (ii) three years after termination without cause or for good reason six months prior to, or two years following, a change-in-control. Mr. Trevathan's employment agreement gives him the ability to exercise all stock options granted before 2004 for two years after termination of employment (i) without cause or for good reason or (ii) without cause or for good reason six months prior to, or two years following, a change-in-control. Our employment agreements with Messrs. Preston, Harris and Woods do not provide for extended exercisability of their stock options upon termination. The value, if any, to executives of the benefit of extended exercisability of options is dependent on whether the market value of our Common Stock exceeds the exercise prices of the stock options during the post-termination period of exercisability. The following is a calculation of the potential gain the named executive could have realized if their vested stock options were exercised as of December 31, 2011: Mr. Steiner — \$5,601,768; Mr. Trevathan — \$2,129,050; Mr. Harris — \$0; and Mr. Woods — \$518,200.

Mr. Simpson retired from the Company on September 30, 2011. Mr. Simpson's retirement did not trigger any severance or other compensation payments. In accordance with the applicable equity award agreements, Mr. Simpson will receive the benefits set forth below, which are calculated using the closing price of the Company's Common Stock of \$32.71 per share on December 31, 2011. The payout value shown for performance share unit awards assumes that target performance was achieved; however, any actual performance share unit payouts will be based on actual performance of the Company during the full performance period.

- Prorated payment of performance share units granted in 2010 and 2011 \$415,810
- Continued exercisability of vested options \$314,370

Equity Compensation Plan Table

The following table provides information as of December 31, 2011 about the number of shares to be issued upon vesting or exercise of equity awards and the number of shares remaining available for issuance under our equity compensation plans.

| <u>Plan Category</u> | <u>Number of Securities to be Issued Upon Exercise of Outstanding Options and Rights</u> | <u>Weighted-Average Exercise Price of Outstanding Options and Rights</u> | <u>Number of Securities Remaining Available for Future Issuance Under Equity Compensation Plans</u> |
|---|--|--|---|
| Equity compensation plans approved by security holders(a) | 16,917,793(b) | \$32.92(c) | 9,607,260(d) |
| Equity compensation plans not approved by security holders(e) | 61,646(f) | \$29.11 | 0 |
| Total | 16,979,439 | \$32.91 | 9,607,260 |

(a) Includes our 1993 Stock Incentive Plan, 2000 Stock Incentive Plan, 2004 Stock Incentive Plan and 2009 Stock Incentive Plan. Only our 2009 Stock Incentive Plan is available for awards. Also includes our Employee Stock Purchase Plan (ESPP).

(b) Includes: options outstanding for 14,193,402 shares of Common Stock; 445,014 shares of Common Stock to be issued in connection with deferred compensation obligations; 317,127 shares underlying unvested restricted stock units and up to 1,962,250 shares of Common Stock that may be issued under unearned performance share units. In determining the number of shares of Common Stock that may be issued on account of performance share units, we assumed the maximum performance level was achievable, which would result in a payout in shares of Common Stock equal to two times the number of performance share units granted. This number does not include 930,293 shares of Common Stock that were earned as of December 31, 2011 on account of vested performance share units. Those shares of Common Stock were

issued to employees in February 2012. Excludes purchase rights that accrue under the ESPP. Purchase rights under the ESPP are considered equity compensation for accounting purposes; however, the number of shares to be purchased is indeterminable until the time shares are actually issued, as automatic employee contributions may be terminated before the end of an offering period and, due to the look-back pricing feature, the purchase price and corresponding number of shares to be purchased is unknown.

- (c) Excludes performance share units and restricted stock units because those awards do not have exercise prices associated with them. Also excludes purchase rights under the ESPP for the reasons described in (b) above.
- (d) The shares remaining available include 8,938,274 shares under our 2009 Stock Incentive Plan and 668,986 shares under our ESPP. No additional shares may be issued under any of the other plans approved by stockholders, other than on account of awards already outstanding.
- (e) Includes our 2000 Broad-Based Employee Plan. No awards under the Broad-Based Plan are held by, or may be granted to, any of our directors or executive officers. The Broad-Based Plan allows for the granting of equity awards on such terms and conditions as the MD&C Committee may decide; provided, that the exercise price of options may not be less than 100% of the fair market value of the stock on the date of grant, and all options expire no later than ten years from the date of grant.
- (f) Includes options exercisable for shares of Common Stock.

**RATIFICATION OF INDEPENDENT REGISTERED PUBLIC ACCOUNTING FIRM
(Item 2 on the Proxy Card)**

Our Board of Directors, upon the recommendation of the Audit Committee, has ratified the selection of Ernst & Young LLP to serve as our independent registered public accounting firm for fiscal year 2012, subject to ratification by our stockholders.

Representatives of Ernst & Young LLP will be at the Annual Meeting. They will be able to make a statement if they want, and will be available to answer any appropriate questions stockholders may have.

Although ratification of the selection of Ernst & Young is not required by our By-laws or otherwise, we are submitting the selection to stockholders for ratification because we value our stockholders' views on our independent registered public accounting firm and as a matter of good governance. If our stockholders do not ratify our selection, it will be considered a direction to our Board and Audit Committee to consider selecting another firm. Even if the selection is ratified, the Audit Committee may, in its discretion, select a different independent registered public accounting firm, subject to ratification by the Board, at any time during the year if it determines that such a change is in the best interests of the Company and our stockholders.

THE BOARD OF DIRECTORS RECOMMENDS THAT YOU VOTE FOR THE RATIFICATION OF ERNST & YOUNG LLP AS THE COMPANY'S INDEPENDENT REGISTERED PUBLIC ACCOUNTING FIRM FOR FISCAL YEAR 2012.

Independent Registered Public Accounting Firm Fee Information

Fees for professional services provided by our independent registered public accounting firm in each of the last two fiscal years, in each of the following categories, were as follows:

| | 2011 | 2010 |
|---------------------------------|---------------|-------|
| | (In millions) | |
| Audit Fees | \$5.3 | \$5.7 |
| Audit-Related Fees | 1.6 | 1.3 |
| Tax Fees | 0.0 | 0.0 |
| All Other Fees | 0.0 | 0.0 |
| Total | \$6.9 | \$7.0 |

Audit includes fees for the annual audit, reviews of the Company's Quarterly Reports on Form 10-Q, work performed to support the Company's debt issuances, accounting consultations, and separate subsidiary audits required by statute or regulation, both domestically and internationally. Audit-related fees principally include separate subsidiary audits not required by statute or regulation, employee benefit plan audits and financial due diligence services relating to certain potential acquisitions.

The Audit Committee has adopted procedures for the approval of Ernst & Young's services and related fees. At the beginning of each year, all audit and audit-related services, tax fees and other fees for the upcoming audit are provided to the Audit Committee for approval. The services are grouped into significant categories and provided to the Audit Committee in the format shown above. All projects that have the potential to exceed \$100,000 are separately identified and reported to the Committee for approval. The Audit Committee Chairman has the authority to approve additional services, not previously approved, between Committee meetings. Any additional services approved by the Audit Committee Chairman between Committee meetings are ratified by the full Audit Committee at the next regularly scheduled meeting. The Audit Committee is updated on the status of all services and related fees at every regular meeting. In 2011 and 2010, the Audit Committee pre-approved all audit and audit-related services performed by Ernst & Young.

As set forth in the Audit Committee Report on page 8, the Audit Committee has considered whether the provision of these audit-related services is compatible with maintaining auditor independence and has determined that they are.

Vote Required for Approval

Approval of this proposal requires the affirmative vote of a majority of the shares present at the meeting, in person or represented by proxy, and entitled to vote.

ADVISORY VOTE ON EXECUTIVE COMPENSATION **(Item 3 on the Proxy Card)**

Pursuant to Section 14A of the Securities Exchange Act of 1934, as amended, stockholders are entitled to an advisory (non-binding) vote on compensation programs for our named executive officers (sometimes referred to as “say on pay”). The Board of Directors has determined that it will include say on pay votes in the Company’s proxy materials annually until the next stockholder vote on the frequency of the say on pay vote.

We encourage stockholders to review the Compensation Discussion and Analysis on pages 22 to 39 of this Proxy Statement. The Company has designed its executive compensation program to be supportive of, and align with, the strategy of the Company and the creation of stockholder value, while discouraging excessive risk-taking. The following key structural elements and policies, discussed in more detail in the Compensation Discussion and Analysis, further the objective of our executive compensation program and evidence our dedication to competitive and reasonable compensation practices that are in the best interests of stockholders:

- a substantial portion of executive compensation is linked to Company performance, through annual cash performance criteria and long-term incentive awards. As a result, our executive compensation program provides for a significant difference in total compensation in periods of above-target Company performance as compared to periods of below-target Company performance;
- performance measures are designed to be challenging, yet achievable;
- performance based awards include threshold, target and maximum payouts correlating to a range of performance and are based on a variety of indicators of performance, which limits risk-taking behavior;
- our compensation mix targets approximately 50% of total compensation of our named executives (and approximately 68% in the case of our Chief Executive Officer) to result from long-term equity awards, which aligns executives’ interests with those of stockholders. The MD&C Committee altered the overall compensation allocation of operational leaders in 2011 to increase the weight of long-term equity compensation;
- performance stock units’ three-year performance period, as well as stock options’ vesting over a three-year period, link executives’ interests with long-term performance and reduce incentives to maximize performance in any one year;
- all of our named executive officers are subject to stock ownership requirements, which we believe demonstrates a commitment to, and confidence in, the Company’s long-term prospects;
- the Company has clawback provisions in its equity award agreements and recent employment agreements, as well as a general clawback policy designed to recoup compensation in certain cases when cause and/or misconduct are found;
- our executive officer severance policy implemented a limitation on the amount of benefits the Company may provide to its executive officers under severance agreements entered into after the date of such policy; and
- the Company has adopted a policy that prohibits it from entering into new agreements with executive officers that provide for certain death benefits or tax gross-up payments.

The Board strongly endorses the Company’s executive compensation program and recommends that the stockholders vote in favor of the following resolution:

RESOLVED, that the stockholders approve the compensation of the Company’s named executive officers as described in this Proxy Statement under “Executive Compensation,” including the Compensation Discussion and Analysis and the tabular and narrative disclosure contained in this Proxy Statement.

Vote Required for Approval

Approval of this proposal requires the affirmative vote of a majority of the shares present at the meeting, in person or represented by proxy, and entitled to vote. Because the vote is advisory, it will not be binding upon the Board or the MD&C Committee and neither the Board nor the MD&C Committee will be required to take any action as a result of the outcome of the vote on this proposal. The MD&C Committee will carefully consider the outcome of the vote in connection with future executive compensation arrangements.

THE BOARD RECOMMENDS THAT YOU VOTE FOR THE APPROVAL OF THE COMPANY'S EXECUTIVE COMPENSATION.

**PROPOSAL TO AMEND THE COMPANY'S EMPLOYEE STOCK PURCHASE PLAN
(Item 4 on the Proxy Card)**

Description of the Proposed Amendment

Our Employee Stock Purchase Plan was approved by stockholders at our 1997 Annual Meeting. An aggregate of 1,000,000 shares of Common Stock was originally authorized for issuance under the ESPP and stockholders have approved an additional 8,750,000 shares for issuance since then. As of March 13, 2012, approximately 32,000 employees were eligible to participate in the ESPP and less than 700,000 shares remained available for issuance. Therefore, the Board of Directors has concluded it is in the best interest to amend the ESPP to authorize an additional 3,000,000 shares of Common Stock for issuance under the ESPP, subject to stockholder approval.

Description of the ESPP

The following description of the ESPP is qualified in its entirety by, and should be read in conjunction with, the text of the ESPP, a copy of which, as proposed to be amended, is attached hereto as Appendix A.

Purpose

The purpose of the ESPP is to provide an incentive for present and future employees of the Company and its participating subsidiaries to acquire or increase their proprietary interest in the Company through the purchase of shares of Common Stock at a discount.

Administration

The ESPP is administered by the Administrative Committee of the Waste Management Employee Benefit Plans, a committee appointed by the Board of Directors. The Administrative Committee has the authority to interpret all provisions of the ESPP.

Eligibility

Any employee who customarily works for the Company or one of its participating subsidiaries at least 20 hours per week and more than five months in a calendar year is eligible to participate in the ESPP after having been employed for at least 30 days prior to an enrollment date.

Operation of the ESPP

On the last day of each six-month period between January 1 and June 30 and July 1 and December 31 (each, an "Offering Period"), each employee who is enrolled in the ESPP will automatically purchase a number of shares of Common Stock determined by dividing such employee's payroll deductions accumulated in the ESPP during such Offering Period by the Offering Price. The Offering Price of each of the shares purchased in a given Offering Period shall be the lower of (a) 85% of the fair market value of a share of Common Stock on the first day of the Offering Period and (b) 85% of the fair market value of a share of Common Stock on the last day of the Offering Period. If an employee withdraws from participation during an Offering Period, the monies contributed to the Plan are refunded immediately without interest.

Eligible employees may elect to participate in the ESPP by completing an enrollment agreement that authorizes payroll deductions from the employee's pay in an amount from 1% to 10% (in whole percentages) of the employee's gross base pay. No employee may (a) make payroll deductions during any calendar year in excess of \$21,250; (b) purchase shares under the ESPP if such purchase would result in the employee owning five percent or more of the total combined voting power or value of the Company's outstanding capital stock; or (c) purchase shares under the ESPP with a fair market value in excess of \$25,000 per calendar year.

All payroll deductions for the ESPP are placed in our general corporate account. No interest accrues on the payroll deductions. Employees may purchase Common Stock under the ESPP only through payroll deductions, and an employee participating in the ESPP may not make any additional payments into the account.

Termination of Employment and Withdrawal

If an employee withdraws from participation in the ESPP or terminates employment for any reason, including retirement or death, during an Offering Period, the payroll deductions credited to the employee's account will be refunded promptly without interest.

Amendment and Termination of ESPP

The Board of Directors may amend the ESPP at any time; provided, however, the ESPP may not be amended in any way (a) that will cause rights issued thereunder to fail to meet the requirements for employee stock purchase plans as defined in Section 423 of the Internal Revenue Code of 1986, as amended (the "Code") or (b) that requires stockholder approval, unless such stockholder approval is obtained.

The ESPP will terminate on the earlier of (a) the date that participating employees become entitled to purchase an aggregate number of shares greater than the number of shares remaining available for purchase under the ESPP and (b) the date on which the ESPP is terminated by the Board of Directors.

Federal Income Tax Consequences

The following discussion is intended to be a general summary only of the federal income tax aspects of purchase rights granted under the ESPP and not of state or local taxes that may be applicable. Tax consequences may vary depending on the particular circumstances, and administrative and judicial interpretations of the application of the federal income tax laws are subject to change. Participants in the ESPP who are residents of or are employed in a country other than the United States may be subject to taxation in accordance with the tax laws of that particular country in addition to or in lieu of U.S. federal income taxes.

The ESPP is intended to be an "employee stock purchase plan" as defined in Section 423 of the Code. A participant recognizes no taxable income either as a result of commencing participation in the ESPP or purchasing Common Stock under the terms of the ESPP. If a participant disposes of shares purchased under the ESPP within either two years from the first day of the applicable Offering Period or within one year from the purchase date, known as disqualifying dispositions, the participant will realize ordinary income in the year of such disposition equal to the amount by which the fair market value of the shares on the purchase date exceeds the purchase price. The amount of the ordinary income will be added to the participant's basis in the shares, and any additional gain or resulting loss recognized on the disposition of the shares will be a capital gain or loss, which will be long-term if the participant's holding period is more than 12 months. If the participant disposes of shares purchased under the ESPP at least two years after the first day of the applicable Offering Period and at least one year after the purchase date, the participant will realize ordinary income in the year of disposition equal to the lesser of (a) the excess of the fair market value of the shares on the date of disposition over the purchase price or (b) 15% of the fair market value of the shares on the first day of the applicable Offering Period. The amount of any ordinary income will be added to the participant's basis in the shares, and any additional gain recognized upon the disposition after such basis adjustment will be a long-term capital gain. If the fair market value of the shares on the date of disposition is less than the purchase price, there will be no ordinary income and any loss recognized will be a long-term capital loss. If the participant still owns the shares at the time of death, the lesser of (a) the excess of the fair market value of the shares on the date of death over the purchase price or (b) 15% of the fair market value of the shares on the first day of the Offering Period in which the shares were purchased will constitute ordinary income in the year of death. Any ordinary income recognized by a participant upon the disqualifying disposition of the shares generally should be deductible by the Company for federal income tax purposes, except to the extent such deduction is limited by applicable provisions of the Code or the regulations thereunder.

New Plan Benefits

The value of the Common Stock purchased through the ESPP will vary based on the fair market value of our Common Stock on the first and last days of the Offering Period. Accordingly, the number of shares that may be purchased by the named executive officers, the executive officers as a group and all employees, including all

current officers who are not executive officers, as a group in the future is not currently determinable. However, the table below shows, as to each of the indicated individuals and groups, the number of shares of Common Stock purchased by such individuals during the 2011 Offering Periods under the ESPP. The weighted average purchase price per share of Common Stock purchased during the 2011 Offering Periods under the ESPP was \$29.44. Non-employee directors of the Company are not eligible to participate in the ESPP.

| <u>Name/Group</u> | <u>Number of Shares</u> |
|--|-----------------------------|
| David P. Steiner | 679 |
| Steven C. Preston | 0 |
| James E. Trevathan | 0 |
| Jeff M. Harris | 0 |
| Duane C. Woods | 679 |
| Robert G. Simpson | 679 |
| All current executive officers as a group | 7,711 |
| All current employees, including all current officers who are not executive officers, as a group | 911,817 |

Vote Required for Approval

The affirmative vote of the holders of a majority of the shares of Waste Management Common Stock present or represented by proxy and entitled to vote at the meeting is required for approval of the amendment to the ESPP, provided, however, under the rules of the New York Stock Exchange, votes representing more than 50% of the outstanding shares of Common Stock must be cast on the proposal. Broker non-votes are not considered votes for this purpose.

THE BOARD OF DIRECTORS RECOMMENDS THAT YOU VOTE FOR THE APPROVAL OF THE AMENDMENT TO THE EMPLOYEE STOCK PURCHASE PLAN.

**STOCKHOLDER PROPOSAL REGARDING STOCK RETENTION POLICY
FOR SENIOR EXECUTIVES
(Item 5 on the Proxy Card)**

Waste Management is not responsible for the content of this stockholder proposal or supporting statement.

The following proposal was submitted by Mr. Kenneth Steiner, 14 Stoner Ave., 2M, Great Neck, NY 11021, the beneficial owner of 700 shares of Waste Management Common Stock. The proposal has been included verbatim as we received it.

Stockholder Proposal

5 — Executives to Retain Significant Stock

RESOLVED, Shareholders urge that our executive pay committee adopt a policy requiring that senior executives retain a significant percentage of stock acquired through equity pay programs until one-year following the termination of their employment and to report to shareholders regarding this policy before our next annual shareholder meeting.

Shareholders recommend that our executive pay committee adopt a percentage of 25% of net after-tax stock. The policy shall apply to future grants and awards of equity pay and should address the permissibility of transactions such as hedging transactions which are not sales but reduce the risk of loss to executives. This proposal asks for a retention policy starting as soon as possible.

Requiring senior executives to hold a significant portion of stock obtained through executive pay plans after employment termination would focus our executives on our company's long-term success. A Conference Board Task Force report on executive pay stated that at least hold-to-retirement requirements give executives "an ever-growing incentive to focus on long-term stock price performance."

The merit of this proposal should also be considered in the context of the opportunity for additional improvement in our company's 2011 reported corporate governance in order to more fully realize our company's potential:

The Corporate Library, an independent investment research firm, said our executive pay was not sufficiently linked to company performance. As an example, our executive pay committee had the discretion to increase annual bonuses up to 25% for an individual executive's contribution which undermines the effectiveness of structured incentive pay.

In addition, CEO David Steiner's base salary continued to be over the IRC tax deductibility limit. When base salaries for those executives subject to 162(m) exceed the limit, it raises concerns about the decision-making of our board when it comes to protecting shareholder interests.

The Corporate Library said named executive officers received stock options in 2010 that simply vest after time. To be effective, equity pay given as a long-term incentive should include performance-vesting features. Moreover, market-priced stock options may provide rewards simply due to a rising market, regardless of an executive's performance. Finally, the equity ownership guidelines of 165,000 shares for our CEO was too low, considering his receiving 331,000 options in 2010. Taken together, these facts suggest that our executive pay practices are not aligned with shareholders' interests.

Please encourage our board to respond positively to this proposal: **Executives to Retain Significant Stock — Yes on 5.**

Waste Management Response to Stockholder Proposal Regarding Executive Stock Retention Policy

The Board recommends that stockholders vote AGAINST this proposal.

The Board believes that this proposal is unnecessary, given that the Company already maintains effective Stock Ownership Guidelines that currently impose a higher ownership requirement on the Company's senior executives than the proponent's proposal, and that it likely would be detrimental to the Company and its

stockholders. The Company's Stock Ownership Guidelines were implemented by the wholly-independent MD&C Committee in 2002. These guidelines are reviewed at least annually and are revised as appropriate. As stated in our Compensation Discussion and Analysis under "Other Compensation Policies and Practices," we instituted stock ownership guidelines because ownership of Company stock demonstrates a commitment to, and confidence in, the Company's long-term prospects. We believe that the requirement that these individuals maintain a portion of their individual wealth in the form of Company stock deters actions that would not benefit stockholders generally. Accordingly, the Board believes the existing Stock Ownership Guidelines, together with the fact that a substantial portion of executive compensation is linked to Company performance through annual cash bonus performance criteria and long-term incentive programs, already successfully align the interests of senior executives with those of stockholders and focuses executives appropriately on long-term performance.

As described earlier in this Proxy Statement, the Company's current Stock Ownership Guidelines vary depending on the individual executive's title and are expressed as a fixed number of shares. The Stock Ownership Guidelines apply to all senior executive management and selected Vice Presidents. Examples of ownership requirements are 165,000 shares for our Chief Executive Officer; 48,000 shares for our Executive Vice Presidents and Senior Group Vice Presidents; and 25,575 shares for Senior Corporate Vice Presidents. Shares owned outright, deferred stock units, and phantom stock held in the 401(k) plan and in the Deferral Plan count toward meeting the targeted ownership requirements. Restricted stock shares, restricted stock units and performance share units, if any, do not count toward meeting the requirement until they are vested or earned.

The existing Stock Ownership Guidelines also contain a holding requirement. Until the individual's ownership requirement is achieved, Senior Vice Presidents and above are required to retain 100% of all net shares acquired through the Company's long-term incentive plans and Vice Presidents are required to retain at least 50% of such net shares. The requisite stock ownership level must thereafter be retained throughout the officer's employment with the Company. Additionally, the Stock Ownership Guidelines generally require Senior Vice Presidents and above to hold all of their net shares and Vice Presidents to hold 50% of their net shares for at least one year after such shares are acquired, even if required ownership levels have already been achieved. The Board believes these holding periods discourage these individuals from taking actions in an effort to gain from short-term or otherwise fleeting increases in the market value of our stock.

In the case of each of our senior executive officers, the amount of stock he is required to hold under our existing Stock Ownership Guidelines is greater than 25% of the total number of shares that he owns. Therefore, even if the proponent's proposed 25% ownership requirement applied to all shares owned (as opposed to only shares acquired through equity pay programs), and even if the proposed 25% ownership requirement applied to shares acquired in the past (as opposed to only future grants and awards), the existing Stock Ownership Guidelines already impose a higher ownership requirement than the proponent proposes. As a result, not only is the proposed 25% threshold currently moot, but it would require far more onerous and complex means to monitor compliance than the current guidelines that state a flat number of shares that must be owned, regardless of how acquired. We also note that the proponent's proposal makes reference to the number of options issued to our Chief Executive Officer last year; however, such options vest over time and then must later be exercised; accordingly, our Chief Executive Officer does not yet have ownership of any shares of Common Stock associated with those options, making the unvested options irrelevant for purposes of stock ownership requirements.

The proponent does not offer any explanation as to why stock retention after termination of an executive's employment contributes to the long-term value of the Company. This proposed requirement would be an administrative burden to the Company and could, in fact, result in an executive's ultimate equity award being dramatically affected by matters completely unrelated to the Company's performance or the executive's actions during the period of the executive's employment with the Company. This unfair and arbitrary result would likely hinder the ability of the Company to attract and retain executive talent.

The MD&C Committee's annual review of the Stock Ownership Guidelines allows for prudent and reasoned adjustment of the ownership guidelines on a regular basis in light of all facts and circumstances. It is in the best interests of the Company and the stockholders to allow the MD&C Committee the flexibility to employ its expertise to fulfill this function, as opposed to relying on a rigid policy. For these and the other reasons discussed above, the Board believes that this proposal is not in the best interests of the Company or its stockholders.

Regarding the other elements of the Company's executive compensation program mentioned in the proponent's proposal, we urge stockholders to read our Compensation Discussion and Analysis for a complete discussion of all elements of our executive compensation program. Our Compensation Discussion and Analysis provides a more fulsome explanation of how the various elements of executive compensation are carefully crafted to attract, retain, reward and incentivize exceptional, talented employees who will lead the Company in the successful execution of its strategy. Additionally, the Company's clawback policies (described further in our Compensation Discussion and Analysis) and its policy prohibiting designated insiders from hedging the economic risk of their ownership of Waste Management shares further complement the objectives of our Stock Ownership Guidelines. Our Compensation Discussion and Analysis also notes that, while the MD&C Committee has the discretion to increase or decrease an individual's annual cash bonus by up to 25%, this modifier has never been used to increase payment to a named executive officer.

Vote Required for Approval

If this proposal is properly presented at the meeting, approval requires the affirmative vote of a majority of the shares present at the meeting, in person or represented by proxy, and entitled to vote.

THE BOARD OF DIRECTORS RECOMMENDS THAT YOU VOTE AGAINST THE ADOPTION OF THIS PROPOSAL.

**STOCKHOLDER PROPOSAL REGARDING RIGHT OF STOCKHOLDERS
TO CALL A SPECIAL STOCKHOLDER MEETING
(Item 6 on the Proxy Card)**

Waste Management is not responsible for the content of this stockholder proposal or supporting statement.

The following proposal was submitted by Mr. William Steiner, 112 Abbottsford Gate, Piermont, NY 10968, the beneficial owner of 13,500 shares of Waste Management Common Stock. The proposal has been included verbatim as we received it.

Stockholder Proposal

6 — Special Shareowner Meetings

Resolved, Shareowners ask our board to take the steps necessary unilaterally (to the fullest extent permitted by law) to amend our bylaws and each appropriate governing document to give holders of the lowest percentage of our outstanding common stock permitted by state law the power to call a special shareowner meeting.

This includes that such bylaw and/or charter text will not have any exclusionary or prohibitive language in regard to calling a special meeting that apply only to shareowners, or only to certain shareholders, but not to management and/or the board (to the fullest extent permitted by law).

Special meetings allow shareowners to vote on important matters, such as electing new directors that can arise between annual meetings. Shareowner input on the timing of shareowner meetings is especially important when events unfold quickly and issues may become moot by the next annual meeting. This proposal does not impact our board's current power to call a special meeting.

Our management scuttled our opportunity to vote on the 2011 shareholder proposal to enable 10% of shareholders to call a special meeting. Our management first told the Securities and Exchange Commission that it would act to allow a much higher 25% of shareholders to call a special meeting. Later our management backtracked and told the SEC that it was adding a further burden to its already more burdensome 25%-threshold and that the 25% of shareholders required would now automatically exclude all shareholders who had owned our stock for less than one-year.

Please encourage our board to respond positively to this proposal to initiate improved corporate governance and financial performance: **Special Shareowner Meetings — Yes on 6.**

Waste Management Response to Stockholder Proposal Regarding Right of Stockholders to Call a Special Stockholder Meeting

The Board recommends that stockholders vote AGAINST this proposal.

The Board strongly believes that this proposal is contrary to the interests of the Company and its stockholders.

Waste Management is a Delaware corporation, and under applicable state law, there is no minimum percentage of outstanding Common Stock that may be authorized to call a special meeting. As a result, this proposal, if implemented, would permit any owner of *one single share of stock* to call a special meeting at any time and with any frequency. This would be true regardless of how long the stockholder has held our stock. Additionally, the meetings called could cover agenda items in which stockholders generally have little or no interest or that are relevant to only very narrow constituencies, or even to only one single stockholder. Allowing meetings to be called in this manner would be disruptive to the Company's operations and time-consuming for management. Meetings of stockholders are expensive, and allowing a possibly unlimited number of meetings to be called by the owner of one share of stock is not a responsible use of time or financial resources. ***The Board believes that the proponent's proposal to permit any person to acquire one single share of the Company's Common Stock and then call a special stockholder meeting is unreasonable and clearly would not be in the best interests of our stockholders.***

The Board has already acted to permit stockholders who own 25% or more of the Company's Common Stock, in the aggregate, to call a special meeting. The Board believes that an ownership threshold of 25% strikes a reasonable balance between enhancing stockholder rights and protecting against the risk that a small minority of stockholders could trigger a special meeting and the resulting financial expense and disruption to the Company's business. The Board believes special meetings should only be called to consider extraordinary events that are of interest to a broad base of stockholders and that cannot wait until the next annual meeting. For every special meeting of stockholders, the Company is required to provide each holder of its Common Stock a notice and proxy materials, which results in significant legal, printing and mailing expenses, as well as other costs normally associated with holding a meeting of stockholders. Additionally, preparing for stockholder meetings requires significant attention of the Company's directors, officers and employees, diverting their attention away from performing their primary function, which is to operate the Company's business in the best interests of the stockholders. The existing 25% threshold for the right of stockholders to call a special meeting provides stockholders a meaningful ability to request that the Board call a special meeting, while helping protect against these concerns. The requirement that stockholders requesting a special meeting must have held a net long position in the Company's Common Stock for at least one year ensures that stockholders seeking to exercise the right have a true economic interest in the Company. Further, the current By-laws contain various exceptions and timing mechanisms that are intended to avoid the cost and distraction that would result from multiple stockholder meetings being held in a short time period.

The Board is strongly committed to good governance practices and is keenly interested in the views and concerns of our stockholders. In addition to the existing right of stockholders to call a special meeting, our stockholders have the ability to act by written consent. We also provide significant opportunity for our stockholders to raise matters at our annual meetings. Stockholders have frequently used our annual meetings to propose business by making proposals through the proxy rules, such as this one, and are able to communicate their concerns during the question and answer session of an annual meeting. Institutional Shareholder Services, Inc. has rated our shareholder rights practices as a "low concern," which is its lowest rating. The Corporate Library has assigned the Board a "Low" Corporate Governance Risk Assessment, indicating that our Company's governance practices are not a cause for concern.

In light of the Board's continuing commitment to ensuring effective corporate governance, and the other reasons outlined in this response, the Board believes that adopting a proposal that would permit any holder of one single share of the Company's Common Stock to call a special stockholder meeting would be detrimental to the Company and its stockholders.

Vote Required for Approval

If this proposal is properly presented at the meeting, approval requires the affirmative vote of a majority of the shares present at the meeting, in person or represented by proxy, and entitled to vote.

THE BOARD OF DIRECTORS RECOMMENDS THAT YOU VOTE AGAINST THE ADOPTION OF THIS PROPOSAL.

OTHER MATTERS

We do not intend to bring any other matters before the Annual Meeting, nor do we have any present knowledge that any other matters will be presented by others for action at the meeting. If any other matters are properly presented, your proxy card authorizes the people named as proxy holders to vote using their judgment.

Appendix A

WASTE MANAGEMENT, INC. EMPLOYEE STOCK PURCHASE PLAN

(As Amended and Restated Effective May 10, 2012)

The Waste Management, Inc. Employee Stock Purchase Plan (the “Plan”) has been established for the benefit of its eligible employees. The terms of the Plan are set forth below.

1. Definitions.

As used in the Plan the following terms shall have the meanings set forth below:

- (a) “Board” means the Board of Directors of the Company.
- (b) “Code” means the Internal Revenue Code of 1986, as amended, and the regulations issued thereunder.
- (c) “Committee” means the Administrative Committee of the Waste Management Employee Benefit Plans appointed by the Board to administer the Plan as described in Section 4 below.
- (d) “Common Stock” means the common stock, \$0.01 par value, of the Company.
- (e) “Company” means Waste Management, Inc., a Delaware corporation, or any successor corporation by merger, reorganization, consolidation or otherwise.
- (f) “Continuous Employment” means the absence of any interruption or termination of service as an Eligible Employee with the Company and/or its Participating Subsidiaries. For purposes of the preceding sentence, an authorized leave of absence shall not be considered an interruption or termination of service, provided that such leave is for a period of not more than 90 days or reemployment upon the expiration of such leave is guaranteed by contract or statute.
- (g) “Eligible Compensation” means, with respect to each Participant for each pay period, the regular base earnings, commissions, overtime and, for employees on an Involuntary Military Leave of Absence, pay differential, paid to the Participant by the Company and/or one or more Participating Subsidiaries during the Offering Period before reductions are made to Code Section 125 and Section 401(k) plans maintained by the Company and/or its Participating Subsidiaries. However, any incentive compensation or other bonus amounts shall be excluded for purposes of determining Eligible Compensation.
- (h) “Eligible Employee” means an employee of the Company or one of its Participating Subsidiaries who is customarily employed for at least 20 hours per week and more than five months in a calendar year, or are absent from active employment while on an Involuntary Military Leave of Absence. For purposes of the preceding sentence, employees who are members of a collective bargaining unit shall be excluded as eligible employees under the Plan, unless their applicable collective bargaining agreement provides for participation in the Plan.
- (i) “Enrollment Date” means the first business day of each Offering Period.
- (j) “Exercise Date” means the last business day of each Offering Period.
- (k) “Exercise Price” means the price per share of Common Stock offered in a given Offering Period, which shall be the lower of: (i) 85% of the Fair Market Value of a share of the Common Stock on the Enrollment Date of such Offering Period, or (ii) 85% of the Fair Market Value of a share of the Common Stock on the Exercise Date of such Offering Period.
- (l) “Fair Market Value” means, with respect to a share of Common Stock as of any Enrollment Date or Exercise Date, the closing price of such Common Stock on the New York Stock Exchange on such date, as

reported in *The Wall Street Journal*. In the event that such a closing price is not available for an Enrollment Date or an Exercise Date, the Fair Market Value of a share of Common Stock on such date shall be the closing price of a share of the Common Stock on the New York Stock Exchange on the last business day prior to such date or such other amount as may be determined by the Committee by any fair and reasonable means.

(m) “Involuntary Military Leave of Absence” means an employee’s leave from employment pursuant to the Company’s Paid Leave of Absence Policy to perform military service obligations in the United States Air Force, Army, Navy, Marines, Coast Guard, Public Health Service Corps or National Guard, and the employee is either drafted or a member of the Reserves called to active duty.

(n) “Offering Period” means each six-month period that begins and ends on the business days that coincide with January 1 through June 30, or July 1 through December 31, or such other period or periods as the Committee may establish. However, if the first and/or last day of an Offering Period begins or ends (as applicable) on a Saturday, Sunday or holiday, then (i) the first day of the Offering Period will begin on the immediately following business day, and/or (ii) the last day of an Offering Period will end on the immediately preceding business day.

(o) “Participant” means an Eligible Employee who has elected to participate in the Plan by filing an enrollment agreement with the Company as provided below in Section 6.

(p) “Participating Subsidiary” means any Subsidiary not excluded from participation in the Plan by the Committee, in its sole discretion.

(q) “Subsidiary” means any domestic or foreign corporation of which the Company owns, directly or indirectly, 50% or more of the total combined voting power of all classes of stock or other equity interests and that otherwise qualifies as a “subsidiary corporation” within the meaning of Section 424(f) of the Code or any successor thereto.

2. Purpose of the Plan.

The purpose of the Plan is to provide an incentive for present and future employees of the Company and its Participating Subsidiaries to acquire a proprietary interest (or increase an existing proprietary interest) in the Company through the purchase of Common Stock. The Company intends that the Plan qualify as an “employee stock purchase plan” under Section 423 of the Code, and that the Plan shall be administered, interpreted and construed in a manner consistent with the requirements of Section 423 of the Code.

3. Shares Reserved for the Plan.

The Company shall reserve for issuance and purchase by Participants under the Plan an aggregate of 12,750,000 shares of Common Stock, subject to adjustment as provided below in Section 13. Shares of Common Stock subject to the Plan may be newly issued shares or treasury shares. If and to the extent that any option to purchase shares of Common Stock shall not be exercised for any reason, or if such right to purchase shares shall terminate as provided herein, the shares that have not been so purchased hereunder shall again become available for the purposes of the Plan, unless the Plan shall have been terminated.

4. Administration of the Plan.

(a) A Committee appointed by the Board shall administer the Plan. The Committee shall have the authority to interpret the Plan, to prescribe, amend and rescind rules and regulations relating to the Plan, to correct any defect or rectify any omission in the Plan, or to reconcile any inconsistency in this Plan and any option to purchase shares granted hereunder, and to make all other determinations necessary or advisable for the administration of the Plan. The Committee’s actions and determinations with respect to the foregoing shall be final, conclusive and binding on all persons. The act or determination of a majority of the members of the Committee shall be deemed to be the act or determination of the entire Committee.

(b) The Committee may, in its discretion, request advice or assistance, or employ such other persons as it deems necessary or appropriate for the proper administration of the Plan, including, but not limited to employing

a brokerage firm, bank or other financial institution to assist in the purchase of shares, delivery of reports or other administrative aspects of the Plan.

5. Eligibility to Participate in the Plan.

Subject to limitations imposed by Section 423(b) of the Code, each Eligible Employee who is employed by the Company or a Participating Subsidiary for 30 days prior to an Enrollment Date shall be eligible to participate in the Plan for the Offering Period beginning on that Enrollment Date.

6. Election to Participate in the Plan.

(a) Each Eligible Employee may elect to participate in the Plan by completing an enrollment agreement in the form provided by the Company and filing such enrollment agreement with the Company prior to the applicable Enrollment Date, unless the Committee establishes another deadline for filing the enrollment agreement with respect to a given Offering Period.

(b) Unless a Participant withdraws from participation in the Plan as provided in Section 10 or authorizes a different payroll deduction by filing a new enrollment agreement prior to the Enrollment Date of a succeeding Offering Period, a Participant who is participating in an Offering Period as of the Exercise Date of such Offering Period shall be deemed to have (i) elected to participate in the immediately succeeding Offering Period and (ii) authorized the same payroll deduction percentage for such immediately succeeding Offering Period as was in effect for such Participant immediately prior to such succeeding Offering Period.

7. Payroll Deductions.

(a) All Participant contributions to the Plan shall be made only by payroll deductions. Each time a Participant files the enrollment agreement with respect to an Offering Period, the Participant shall authorize payroll deductions to be made during the Offering Period in an amount from 1% to 10% (in whole percentages) of the Eligible Compensation that the Participant receives on each payroll date during such Offering Period. Payroll deductions for a Participant shall commence on the first payroll date following the Enrollment Date and shall end on the last payroll date in the Offering Period to which such authorization is applicable, unless sooner terminated by the Participant as provided below in Section 10.

(b) All payroll deductions made for a Participant shall be deposited in the Company's general corporate account and shall be credited to the Participant's account under the Plan. No interest shall accrue on or be credited with respect to the payroll deductions of a Participant under the Plan. A Participant may not make any additional contributions into such account. All payroll deductions received or held by the Company under the Plan may be used by the Company for any corporate purpose, and the Company shall not be obligated to segregate such payroll deductions.

(c) Except as provided in Section 10, a Participant may not change his contribution election during an Offering Period.

(d) Notwithstanding the foregoing provisions of this Section 7, no Participant may make payroll deductions during any calendar year in excess of \$21,250, or such other limit as may be established by the Committee, in its discretion.

8. Grant of Options.

(a) On the Enrollment Date of each Offering Period, subject to the limitations set forth in Sections 3 and 8(b) hereof, each Eligible Employee shall be granted an option to purchase on the Exercise Date for such Offering Period a number of whole and fractional shares of the Company's Common Stock determined by dividing such Eligible Employee's payroll deductions accumulated during the Offering Period by the Exercise Price established for such Offering Period.

(b) Notwithstanding any provision of the Plan to the contrary, no Eligible Employee shall be granted an option under the Plan (i) if, immediately after the grant, such Eligible Employee (or any other person whose

stock would be attributed to such Employee pursuant to Section 424(d) of the Code) would own stock and/or hold outstanding options to purchase stock possessing 5% or more of the total combined voting power or value of all classes of stock of the Company or of any Subsidiary of the Company, or (ii) which permits such Eligible Employee's rights to purchase stock under all employee stock purchase plans of the Company and its Subsidiaries to accrue at a rate which exceeds \$25,000 of fair market value of such stock (determined at the time such option is granted) for each calendar year in which such option is outstanding at any time.

9. Automatic Purchase.

Unless a Participant withdraws from the Plan as provided below in Section 10, the Participant's option for the purchase of shares will be exercised automatically on each Exercise Date for which an enrollment agreement has been filed, and the maximum number of whole and fractional shares subject to the option will be purchased for the Participant at the Exercise Price established for that Offering Period, as provided above in Section 8.

10. Withdrawal; Termination of Employment.

(a) A Participant may withdraw all of the payroll deductions credited to the Participant's account for a given Offering Period by providing written notice to the Company no later than 45 days prior to the last day of such Offering Period. A Participant shall not be permitted to make a partial withdrawal of the payroll deductions credited to his account. All of the Participant's payroll deductions credited to the Participant's account will be paid to him promptly after receipt of the Participant's notice of withdrawal, the Participant's participation in the Plan will be automatically terminated, and no further payroll deductions for the purchase of shares hereunder will be made. Payroll deductions will not resume on behalf of a Participant who has withdrawn from the Plan, unless written notice is delivered to the Company within the enrollment period preceding the commencement of a new Offering Period directing the Company to resume payroll deductions.

(b) Upon termination of the Participant's Continuous Employment prior to the Exercise Date of the Offering Period for any reason, including retirement or death, the payroll deductions credited to the Participant's account will be returned to the Participant or, in the case of death, to the Participant's estate, and the Participant's options to purchase shares under the Plan will be automatically terminated.

(c) In the event a Participant ceases to be an Eligible Employee during an Offering Period, the Participant will be deemed to have elected to withdraw all payroll deductions credited to his account from the Plan. In such circumstance, the payroll deductions credited to the Participant's account will be returned to the Participant, and the Participant's options to purchase shares under the Plan will be terminated.

11. Transferability.

Options to purchase Common Stock granted under the Plan are not transferable, in any manner, by a Participant and are exercisable only by the Participant.

12. Reports.

Individual accounts will be maintained for each Participant in the Plan. Following each Exercise Date, statements of account will be given to Participants who have purchased shares under Section 9. Such statements will set forth the amounts of payroll deductions, the per share purchase price, the number of shares purchased and the remaining cash balance, if any.

13. Adjustments Upon Changes in Capitalization.

(a) If the outstanding shares of Common Stock are increased or decreased, or are changed into or are exchanged for a different number or kind of shares, as a result of one or more reorganizations, restructurings, recapitalizations, reclassifications, stock splits, reverse stock splits, stock dividends or the like, upon authorization of the Committee, appropriate adjustments shall be made in the number and/or kind of shares, and the per share purchase price thereof, which may be issued in the aggregate and to any Participant upon exercise of options granted under the Plan.

(b) In the event of the proposed dissolution or liquidation of the Company, each Offering Period will terminate immediately prior to the consummation of such proposed action, unless otherwise provided by the Committee. In the event of a proposed sale of all or substantially all of the assets of the Company, or the merger of the Company with or into another corporation, each option under the Plan shall be assumed or an equivalent option shall be substituted by such successor corporation or a parent or subsidiary of such successor corporation, unless the Committee determines, in the exercise of its sole discretion and in lieu of such assumption or substitution, that the Participant shall have the right to exercise the option as to all of the optioned stock, including shares as to which the option would not otherwise be exercisable. If the Committee makes an option fully exercisable in lieu of assumption or substitution in the event of a merger or sale of assets, the Committee shall notify the Participant that the option shall be fully exercisable for a stated period, which shall not be less than 10 days from the date of such notice, and the option will terminate upon the expiration of such period.

(c) In all cases, the Committee shall have full discretion to exercise any of the powers and authority provided under this Section 13, and the Committee's actions hereunder shall be final and binding on all Participants. No fractional shares of stock shall be issued under the Plan pursuant to any adjustment authorized under the provisions of this Section 13.

14. Amendment of the Plan.

The Board may at any time, or from time to time, amend the Plan in any respect; provided, however, that the Plan may not be amended in any way that will cause rights issued under the Plan to fail to meet the requirements for employee stock purchase plans as defined in Section 423 of the Code or any successor thereto, including, without limitation, shareholder approval, if required.

15. Termination of the Plan.

The Plan and all rights of Eligible Employees hereunder shall terminate:

- (a) on the Exercise Date that Participants become entitled to purchase a number of shares greater than the number of reserved shares remaining available for purchase under the Plan; or
- (b) at any time, at the discretion of the Board.

In the event that the Plan terminates under circumstances described in Section 15(a) above, reserved shares remaining as of the termination date shall be sold to Participants on a pro rata basis.

16. Notices.

All notices or other communications by a Participant to the Company under or in connection with the Plan shall be deemed to have been duly given when received in the form specified by the Company at the location, or by the person, designated by the Company for the receipt thereof.

17. Shareholder Approval.

The Plan shall be subject to approval by the shareholders of the Company within twelve months after the date the Plan is adopted by the Board of Directors. If such shareholder approval is not obtained prior to the first Exercise Date, the Plan shall be null and void and all Participants shall be deemed to have withdrawn all payroll deductions credited to their accounts on such Exercise Date pursuant to Section 10.

18. Conditions Upon Issuance of Shares.

(a) The Plan, the grant and exercise of options to purchase shares of Common Stock under the Plan, and the Company's obligation to sell and deliver shares upon the exercise of options to purchase shares shall be subject to all applicable federal, state and foreign laws, rules and regulations, and to such approvals by any regulatory or governmental agency as may, in the opinion of counsel for the Company, be required. Notwithstanding anything in the Plan to the contrary, share certificates shall not be delivered to Participants until the later of (i) the date on which the applicable holding period to avoid a disqualifying disposition (within the meaning of Code

Section 421) expires, or (ii) the date that a Participant specifically requests a certificate for shares purchased pursuant to the Plan.

(b) The Company may make such provisions, as it deems appropriate, for withholding by the Company pursuant to all applicable tax laws of such amounts as the Company determines it is required to withhold in connection with the purchase or sale by a Participant of any Common Stock acquired pursuant to the Plan. The Company may require a Participant to satisfy any relevant tax requirements before authorizing any issuance of Common Stock to such Participant.

UNITED STATES SECURITIES AND EXCHANGE COMMISSION
Washington, D.C. 20549
Form 10-K

(Mark One)

**ANNUAL REPORT PURSUANT TO SECTION 13 OR 15(d)
OF THE SECURITIES AND EXCHANGE ACT OF 1934**

For the fiscal year ended December 31, 2011

OR

**TRANSITION REPORT PURSUANT TO SECTION 13 OR 15(d)
OF THE SECURITIES AND EXCHANGE ACT OF 1934**

For the transition period from to

Commission file number 1-12154

Waste Management, Inc.

(Exact name of registrant as specified in its charter)

Delaware

*(State or other jurisdiction of
incorporation or organization)*

1001 Fannin Street, Suite 4000

Houston, Texas

(Address of principal executive offices)

73-1309529

*(I.R.S. Employer
Identification No.)*

77002

(Zip code)

Registrant's telephone number, including area code:

(713) 512-6200

Securities registered pursuant to Section 12(b) of the Act:

| <u>Title of Each Class</u> | <u>Name of Exchange on Which Registered</u> |
|-------------------------------|---|
| Common Stock, \$.01 par value | New York Stock Exchange |

Indicate by check mark if the registrant is a well-known seasoned issuer, as defined by Rule 405 of the Securities Act. Yes No

Indicate by check mark if the registrant is not required to file reports pursuant to Section 13 or Section 15(d) of the Act. Yes No

Indicate by check mark whether the registrant (1) has filed all reports required to be filed by Section 13 or 15(d) of the Securities Exchange Act of 1934 during the preceding 12 months (or for such shorter period that the registrant was required to file such reports), and (2) has been subject to such filing requirements for the past 90 days. Yes No

Indicate by check mark whether the registrant has submitted electronically and posted on its corporate Web site, if any, every Interactive Data File required to be submitted and posted pursuant to Rule 405 of Regulations S-T (§ 232.405 of this chapter) during the preceding 12 months (or for such shorter period that the registrant was required to submit and post such files). Yes No

Indicate by check mark if disclosure of delinquent filers pursuant to Item 405 of Regulations S-K (§ 229.405 of this chapter) is not contained herein, and will not be contained, to the best of Registrant's knowledge, in definitive proxy or information statements incorporated by reference in Part III of this Form 10-K or any amendment to this Form 10-K.

Indicate by check mark whether the registrant is a large accelerated filer, an accelerated filer, a non-accelerated filer, or a smaller reporting company. See the definitions of "large accelerated filer," "accelerated filer" and "smaller reporting company" in Rule 12b-2 of the Exchange Act. (Check one):

Large accelerated filer Accelerated filer Non-accelerated filer Smaller reporting company

(Do not check if a smaller reporting company)

Indicate by check mark whether the registrant is a shell company (as defined in Rule 12b-2 of the Act). Yes No

The aggregate market value of the voting stock held by non-affiliates of the registrant at June 30, 2011 was approximately \$17.6 billion. The aggregate market value was computed by using the closing price of the common stock as of that date on the New York Stock Exchange ("NYSE"). (For purposes of calculating this amount only, all directors and executive officers of the registrant have been treated as affiliates.)

The number of shares of Common Stock, \$0.01 par value, of the registrant outstanding at February 10, 2012 was 461,374,381 (excluding treasury shares of 168,908,080).

DOCUMENTS INCORPORATED BY REFERENCE

| <u>Document</u> | <u>Incorporated as to</u> |
|--|---------------------------|
| Proxy Statement for the 2012 Annual Meeting of Stockholders | Part III |

WM000529

TABLE OF CONTENTS

| | <u>Page</u> |
|---|-------------|
| PART I | |
| Item 1. Business | 3 |
| Item 1A. Risk Factors | 14 |
| Item 1B. Unresolved Staff Comments | 24 |
| Item 2. Properties | 24 |
| Item 3. Legal Proceedings | 25 |
| Item 4. Mine Safety Disclosures | 25 |
| PART II | |
| Item 5. Market for Registrant’s Common Equity, Related Stockholder Matters and Issuer Purchases of Equity Securities | 26 |
| Item 6. Selected Financial Data | 28 |
| Item 7. Management’s Discussion and Analysis of Financial Condition and Results of Operations | 29 |
| Item 7A. Quantitative and Qualitative Disclosures About Market Risk | 64 |
| Item 8. Financial Statements and Supplementary Data | 66 |
| Item 9. Changes in and Disagreements with Accountants on Accounting and Financial Disclosure | 144 |
| Item 9A. Controls and Procedures | 144 |
| Item 9B. Other Information | 144 |
| PART III | |
| Item 10. Directors, Executive Officers and Corporate Governance | 144 |
| Item 11. Executive Compensation | 145 |
| Item 12. Security Ownership of Certain Beneficial Owners and Management and Related Stockholder Matters | 145 |
| Item 13. Certain Relationships and Related Transactions, and Director Independence | 145 |
| Item 14. Principal Accounting Fees and Services | 145 |
| PART IV | |
| Item 15. Exhibits, Financial Statement Schedules | 145 |

PART I

Item 1. *Business.*

General

The financial statements presented in this report represent the consolidation of Waste Management, Inc., a Delaware corporation; Waste Management's wholly-owned and majority-owned subsidiaries; and certain variable interest entities for which Waste Management or its subsidiaries are the primary beneficiary as described in Note 20 to the Consolidated Financial Statements. Waste Management is a holding company and all operations are conducted by its subsidiaries. When the terms "the Company," "we," "us" or "our" are used in this document, those terms refer to Waste Management, Inc., its consolidated subsidiaries and consolidated variable interest entities. When we use the term "WM," we are referring only to Waste Management, Inc., the parent holding company.

WM was incorporated in Oklahoma in 1987 under the name "USA Waste Services, Inc." and was reincorporated as a Delaware company in 1995. In a 1998 merger, the Illinois-based waste services company formerly known as Waste Management, Inc. became a wholly-owned subsidiary of WM and changed its name to Waste Management Holdings, Inc. ("WM Holdings"). At the same time, our parent holding company changed its name from USA Waste Services to Waste Management, Inc. Like WM, WM Holdings is a holding company and all operations are conducted by subsidiaries. For detail on the financial position, results of operations and cash flows of WM, WM Holdings and their subsidiaries, see Note 23 to the Consolidated Financial Statements.

Our principal executive offices are located at 1001 Fannin Street, Suite 4000, Houston, Texas 77002. Our telephone number at that address is (713) 512-6200. Our website address is www.wm.com. Our annual reports on Form 10-K, quarterly reports on Form 10-Q and current reports on Form 8-K are all available, free of charge, on our website as soon as practicable after we file the reports with the SEC. Our stock is traded on the New York Stock Exchange under the symbol "WM."

We are the leading provider of comprehensive waste management services in North America. Our subsidiaries provide collection, transfer, recycling, and disposal services. We are also a leading developer, operator and owner of waste-to-energy and landfill gas-to-energy facilities in the United States. Our customers include residential, commercial, industrial and municipal customers throughout North America. During 2011, our largest customer represented approximately 1% of annual revenues. We employed approximately 44,300 people as of December 31, 2011.

Through our core waste management services, we own or operate 271 landfill sites, which is the largest network of landfills in our industry. In order to make disposal more practical for larger urban markets, where the distance to landfills or waste-to-energy facilities is typically farther, we manage 287 transfer stations that consolidate, compact and transport waste efficiently and economically. We also use waste to create energy. One method we use involves recovering the gas produced naturally as waste decomposes in landfills for use in the generation of electricity. We also use waste to create energy through a highly efficient combustion process. Our waste-to-energy subsidiary, Wheelabrator Technologies Inc., operates 22 plants that produce clean, renewable energy. We are a leading recycler in North America, handling materials that include paper, cardboard, glass, plastic, metal and electronics. Through our recycling operations, we provide cost-efficient, environmentally sound programs for municipalities, businesses and households across the U.S. and Canada. In addition to traditional waste operations, we are also expanding to increase the service offerings we provide for our customers.

Our Company's goals are targeted at serving our customers, our employees, the environment, the communities in which we work and our stockholders, and achievement of our goals is intended to meet the needs of a changing industry. The waste industry continues to confront significant changes. Our Company and others have recognized the value of the traditional waste stream as a potential resource. Landfill volumes have declined in recent years, as customers are increasingly using alternatives to traditional disposal, such as recycling and composting, while also working to reduce the waste they generate. Accomplishment of our goals will grow our Company and allow us to meet the needs of our customers and communities as they, too, Think Green®. We believe that helping our customers achieve their environmental goals will enable us to achieve profitable growth.

Our Company is dedicated to three transformational goals that we believe will drive continued growth and leadership in a dynamic industry: know more about our customers and how to service them than anyone else; use conversion and processing technology to extract more value from the materials we manage; and continuously improve our operational efficiency. We intend to pursue achievement of our long-term goals in the short-term through efforts to:

- Grow our markets by implementing customer-focused growth, through customer segmentation and through strategic acquisitions, while maintaining our pricing discipline and increasing the amount of recyclable materials we manage each year;
- Grow our customer loyalty;
- Grow into new markets by investing in greener technologies; and
- Pursue initiatives that improve our operations and cost structure.

These efforts will be supported by ongoing improvements in information technologies. We believe that execution of our strategy will provide long-term value to our stockholders. In addition, we intend to continue to return value to our stockholders through common stock repurchases and dividend payments. In December 2011, we announced that our Board of Directors expects that quarterly dividend payments will be increased to \$0.355 per share in 2012, which is a 4.4% increase from the quarterly dividend we paid in 2011. This will result in an increase in the amount of free cash flow that we expect to pay out as dividends for the ninth consecutive year and is an indication of our ability to generate strong and consistent cash flows. All quarterly dividends will be declared at the discretion of our Board of Directors.

Operations

General

We manage and evaluate our principal operations through five Groups. Our four geographic operating Groups, comprised of our Eastern, Midwest, Southern and Western Groups, provide collection, transfer, disposal (in both solid waste and hazardous waste landfills) and recycling services. Our fifth Group is the Wheelabrator Group, which provides waste-to-energy services and manages waste-to-energy facilities and independent power production plants, or IPPs. We also provide additional services that are not managed through our five Groups, as described below. These operations are presented in this report as “Other.”

The table below shows the total revenues (in millions) contributed annually by each of our Groups, or reportable segments, in the three-year period ended December 31, 2011. More information about our results of operations by reportable segment is included in Note 21 to the Consolidated Financial Statements and in *Management’s Discussion and Analysis of Financial Condition and Results of Operations*, included in this report.

| | Years Ended December 31, | | |
|--------------------|--------------------------|-----------------|-----------------|
| | 2011 | 2010 | 2009 |
| Eastern | \$ 3,115 | \$ 2,943 | \$ 2,960 |
| Midwest | 3,213 | 3,048 | 2,855 |
| Southern | 3,390 | 3,461 | 3,328 |
| Western | 3,282 | 3,173 | 3,125 |
| Wheelabrator | 877 | 889 | 841 |
| Other | 1,532 | 963 | 628 |
| Intercompany | <u>(2,031)</u> | <u>(1,962)</u> | <u>(1,946)</u> |
| Total | <u>\$13,378</u> | <u>\$12,515</u> | <u>\$11,791</u> |

The services we provide include collection, landfill (solid and hazardous waste landfills), transfer, waste-to-energy facilities and independent power production plants, recycling and other services, as described below. The following table shows revenues (in millions) contributed by these services for each of the three years indicated:

| | <u>Years Ended December 31,</u> | | |
|--------------------|---------------------------------|-----------------|-----------------|
| | <u>2011</u> | <u>2010</u> | <u>2009</u> |
| Collection | \$ 8,406 | \$ 8,247 | \$ 7,980 |
| Landfill | 2,611 | 2,540 | 2,547 |
| Transfer | 1,280 | 1,318 | 1,383 |
| Wheelabrator | 877 | 889 | 841 |
| Recycling | 1,580 | 1,169 | 741 |
| Other | 655 | 314 | 245 |
| Intercompany | <u>(2,031)</u> | <u>(1,962)</u> | <u>(1,946)</u> |
| Total | <u>\$13,378</u> | <u>\$12,515</u> | <u>\$11,791</u> |

Collection. Our commitment to customers begins with a vast waste collection network. Collection involves picking up and transporting waste and recyclable materials from where it was generated to a transfer station, material recovery facility (“MRF”) or disposal site. We generally provide collection services under one of two types of arrangements:

- For commercial and industrial collection services, typically we have a three-year service agreement. The fees under the agreements are influenced by factors such as collection frequency, type of collection equipment we furnish, type and volume or weight of the waste collected, distance to the disposal facility, labor costs, cost of disposal and general market factors. As part of the service, we provide steel containers to most customers to store their solid waste between pick-up dates. Containers vary in size and type according to the needs of our customers and the restrictions of their communities. Many are designed to be lifted mechanically and either emptied into a truck’s compaction hopper or directly into a disposal site. By using these containers, we can service most of our commercial and industrial customers with trucks operated by only one employee.
- For most residential collection services, we have a contract with, or a franchise granted by, a municipality, homeowners’ association or some other regional authority that gives us the exclusive right to service all or a portion of the homes in an area. These contracts or franchises are typically for periods of three to five years. We also provide services under individual monthly subscriptions directly to households. The fees for residential collection are either paid by the municipality or authority from their tax revenues or service charges, or are paid directly by the residents receiving the service.

Landfill. Landfills are the main depositories for solid waste in North America. At December 31, 2011, we owned or operated 266 solid waste landfills, which represents the largest network of landfills in North America. Solid waste landfills are constructed and operated on land with engineering safeguards that limit the possibility of water and air pollution, and are operated under procedures prescribed by regulation. A landfill must meet federal, state or provincial, and local regulations during its design, construction, operation and closure. The operation and closure activities of a solid waste landfill include excavation, construction of liners, continuous spreading and compacting of waste, covering of waste with earth or other acceptable material and constructing final capping of the landfill. These operations are carefully planned to maintain environmentally safe conditions and to maximize the use of the airspace.

All solid waste management companies must have access to a disposal facility, such as a solid waste landfill. The significant capital requirements of developing and operating a landfill serve as a barrier to landfill ownership and, as a result, third-party haulers often dispose of waste at our landfills. It is usually preferable for our collection operations to use disposal facilities that we own or operate, a practice we refer to as internalization, rather than using third-party disposal facilities. Internalization generally allows us to realize higher consolidated margins and stronger operating cash flows. The fees charged at disposal facilities, which are referred to as tipping fees, are based on several factors, including competition and the type and weight or volume of solid waste deposited.

We also operate five secure hazardous waste landfills in the United States. Under environmental laws, the federal government (or states with delegated authority) must issue permits for all hazardous waste landfills. All of our hazardous waste landfills have obtained the required permits, although some can accept only certain types of hazardous waste. These landfills must also comply with specialized operating standards. Only hazardous waste in a stable, solid form, which meets regulatory requirements, can be deposited in our secure disposal cells. In some cases, hazardous waste can be treated before disposal. Generally, these treatments involve the separation or removal of solid materials from liquids and chemical treatments that transform waste into inert materials that are no longer hazardous. Our hazardous waste landfills are sited, constructed and operated in a manner designed to provide long-term containment of waste. We also operate a hazardous waste facility at which we isolate treated hazardous waste in liquid form by injection into deep wells that have been drilled in certain acceptable geologic formations far below the base of fresh water to a point that is safely separated by other substantial geological confining layers.

Transfer. At December 31, 2011, we owned or operated 287 transfer stations in North America. We deposit waste at these stations, as do other waste haulers. The solid waste is then consolidated and compacted to reduce the volume and increase the density of the waste and transported by transfer trucks or by rail to disposal sites. At December 31, 2011, our WM Healthcare Solutions subsidiary (discussed below) also had 21 smaller transfer operations (separate from its ten processing facilities, but some of which are located at other existing Company facilities) that are permitted to consolidate regulated medical waste collections for disposal.

Access to transfer stations is critical to haulers who collect waste in areas not in close proximity to disposal facilities. Fees charged to third parties at transfer stations are usually based on the type and volume or weight of the waste deposited at the transfer station, the distance to the disposal site and general market factors.

The utilization of our transfer stations by our own collection operations improves internalization by allowing us to retain fees that we would otherwise pay to third parties for the disposal of the waste we collect. It enables us to manage costs associated with waste disposal because (i) transfer trucks, railcars or rail containers have larger capacities than collection trucks, allowing us to deliver more waste to the disposal facility in each trip; (ii) waste is accumulated and compacted at transfer stations that are strategically located to increase the efficiency of our network of operations; and (iii) we can retain the volume by managing the transfer of the waste to one of our own disposal sites.

The transfer stations that we operate but do not own generally are operated through lease agreements under which we lease property from third parties. There are some instances where transfer stations are operated under contract, generally for municipalities. In most cases we own the permits and will be responsible for any regulatory requirements relating to the operation and closure of the transfer station.

Wheelabrator. As of December 31, 2011, we owned or operated 17 waste-to-energy facilities and five independent power production plants, or IPPs, which are located in the Northeast, in the Mid-Atlantic, and in Florida, California and Washington.

At our waste-to-energy facilities, solid waste is burned at high temperatures in specially designed boilers to produce heat that is converted into high-pressure steam. As of December 31, 2011, our waste-to-energy facilities were capable of processing up to 22,300 tons of solid waste each day. In 2011, our waste-to-energy facilities received and processed 8 million tons of solid waste, or approximately 22,000 tons per day.

Our IPPs convert various waste and conventional fuels into steam. The plants burn wood waste, anthracite coal waste (culm), tires, landfill gas and natural gas. These facilities are integral to the solid waste industry, disposing of urban wood, waste tires, railroad ties and utility poles. Our anthracite culm facility in Pennsylvania processes the waste materials left over from coal mining operations from over half a century ago. Ash remaining after burning the culm is used to reclaim the land damaged by decades of coal mining.

We generate steam at our waste-to-energy and IPPs facilities for the production of electricity. We sell the electricity produced at our facilities into wholesale markets, which include investor-owned utilities, power marketers and regional power pools. Some of our facilities also sell steam directly to end users. Fees charged for electricity and steam at our waste-to-energy facilities and IPPs have generally been subject to the terms and conditions of long-term contracts that include interim adjustments to the prices charged for changes in market

conditions such as inflation, electricity prices and other general market factors. During 2010 and 2009, several of our long-term energy contracts and short-term pricing arrangements expired, significantly increasing our waste-to-energy revenues' exposure to volatility attributable to changes in market prices for electricity, which generally correlate with fluctuations in natural gas prices in the markets in which we operate. Our market-price volatility will continue to increase as additional long-term contracts expire. The next long-term contract will expire in March 2012. We use short-term "receive fixed, pay variable" electricity commodity swaps to mitigate the variability in our revenues and cash flows caused by fluctuations in the market prices for electricity. Refer to the *Quantitative and Qualitative Disclosures About Market Risk* section of this report for additional information about the Company's current considerations related to the management of this market exposure.

We continue to look at opportunities to expand our waste-to-energy business. In 2010, we made two investments which increased the total assets of our Wheelabrator Group by \$318 million. In the first quarter of 2010, we paid \$142 million to acquire a 40% equity investment in Shanghai Environment Group ("SEG"), a subsidiary of Shanghai Chengtuo Holding Co., Ltd. As a joint venture partner in SEG, we will participate in the operation and management of waste-to-energy and other waste services in the Chinese market. SEG will also focus on building new waste-to-energy facilities in China. As of December 31, 2011, SEG owned and operated two waste-to-energy facilities, five landfills and five transfer stations. An additional five waste-to-energy facilities were under construction. Our share of SEG's earnings are included in "Equity in net losses in unconsolidated entities" in our Consolidated Statement of Operations. In the second quarter of 2010, we paid \$150 million for the acquisition of a waste-to-energy facility in Portsmouth, Virginia. Additionally, Wheelabrator is actively pursuing development projects with industry partners and pursuing other opportunities to provide waste-to-energy services in the United Kingdom.

Recycling. Our recycling operations provide communities and industries with an alternative to traditional landfill disposal and support our strategic goals to extract more value from the materials we manage. In 2001, we became the first major solid waste company to focus on residential single-stream recycling, which allows customers to mix recyclable paper, plastic and glass in one bin. Residential single-stream programs have greatly increased the recycling rates. Single-stream recycling is possible through the use of various mechanized screens and optical sorting technologies. We have also been advancing the single-stream recycling programs for commercial applications. Recycling involves the separation of reusable materials from the waste stream for processing and resale or other disposition. Our recycling operations include the following:

Materials processing — Through our collection operations, we collect recyclable materials from residential, commercial and industrial customers and direct these materials to one of our MRFs for processing. We operate 107 MRFs where paper, cardboard, metals, plastics, glass, construction and demolition materials and other recyclable commodities are recovered for resale. We also operate 13 secondary processing facilities where recyclable materials can be further processed into raw products used in the manufacturing of consumer goods. Materials processing services include data destruction and automated color sorting.

Plastics materials recycling — Using state-of-the-art sorting and processing technology, we process, inventory and sell plastic commodities making the recycling of such items more cost effective and convenient.

Commodities recycling — We market and resell recyclable commodities to customers world-wide. We manage the marketing of recyclable commodities that are processed in our facilities by maintaining comprehensive service centers that continuously analyze market prices, logistics, market demands and product quality.

Fees for recycling services are influenced by the type of recyclable commodities being processed, the volume or weight of the recyclable material, degree of processing required, the market value of the recovered material and other market factors.

Some of the recyclable materials processed in our MRFs are purchased from various sources, including third parties and our own operations. The cost per ton of material purchased is based on market prices and the cost to transport the processed goods to our customers to whom we sell such materials. The price we pay for recyclable materials is often referred to as a "rebate." Rebates generally are based upon the price we receive for sales of

processed goods and on market conditions, but in some cases are based on fixed contractual rates or on defined minimum per-ton rates. As a result, changes in commodity prices for recycled fiber can significantly affect our revenues, the rebates we pay to our suppliers and our operating income and margins.

Other. Other services not managed within our Groups include the following:

We provide recycling brokerage services which involves managing the marketing of recyclable materials for third parties. The experience of our recycling operations in managing recyclable commodities for our own operations gives us the expertise needed to effectively manage volumes for third parties. Utilizing the resources and knowledge of our recycling operations' service centers, we can assist customers in marketing and selling their recyclable commodities with little to no capital requirements. We also provide electronics recycling. We recycle discarded computers, communications equipment, and other electronic equipment. Services include the collection, sorting and disassembling of electronics in an effort to reuse or recycle all collected materials. In recent years, we have teamed with major electronics manufacturers to offer comprehensive "take-back" programs of their products to assist the general public in disposing of their old electronics in a convenient and environmentally safe manner.

WM Sustainability Services provides a variety of sustainability services to businesses and organizations. This includes in-plant services, where our employees work full-time inside our customers' facilities to provide full-service waste management solutions and consulting services. Our vertically integrated waste management operations enable us to provide customers with full management of their waste. The breadth of our service offerings and the familiarity we have with waste management practices gives us the unique ability to assist customers in minimizing waste they generate, identifying recycling opportunities and determining the most efficient means available for waste collection and disposal.

We develop, operate and promote projects for the beneficial use of landfill gas through our WM Renewable Energy Program. Landfill gas is produced naturally as waste decomposes in a landfill. The methane component of the landfill gas is a readily available, renewable energy source that can be gathered and used beneficially as an alternative to fossil fuel. The EPA endorses landfill gas as a renewable energy resource, in the same category as wind, solar and geothermal resources. At December 31, 2011, landfill gas beneficial use projects were producing commercial quantities of methane gas at 131 of our solid waste landfills. At 102 of these landfills, the processed gas is used to fuel electricity generators. The electricity is then sold to public utilities, municipal utilities or power cooperatives. At 18 landfills, the gas is used at the landfill or delivered by pipeline to industrial customers as a direct substitute for fossil fuels in industrial processes. At ten landfills, the landfill gas is processed to pipeline-quality natural gas and then sold to natural gas suppliers. At one landfill, the gas is processed into liquefied natural gas and used as vehicle fuel.

Although many waste management services such as collection and disposal are local services, our Strategic Accounts program works with customers whose locations span the United States. Our Strategic Accounts program provides centralized customer service, billing and management of accounts to streamline the administration of customers' multiple and nationwide locations' waste management needs. On July 28, 2011, we acquired Oakleaf Global Holdings and its primary operations ("Oakleaf"), which provides outsourced waste and recycling services through a nationwide network of third-party haulers. Oakleaf has increased our national accounts customer base and enhanced our ability to provide comprehensive environmental solutions.

Our WM Healthcare Solutions subsidiary offers integrated medical waste services for healthcare facilities, pharmacies and individuals. We provide full-service solutions to facilities to assist them in best practices, identifying waste streams and proper disposal.

We also have begun investing in businesses and technologies that are designed to offer services and solutions ancillary or supplementary to our current operations. These investments include joint ventures, acquisitions and partial ownership interests. The solutions and services include the collection of project waste, including construction debris and household or yard waste, through our Bagster® program; the development, operation and marketing of plasma gasification facilities; operation of a landfill gas-to-liquid natural gas plant; solar powered trash compactors; and organic waste-to-fuel conversion technology. Part of our expansion of services includes offering portable self-storage services; fluorescent bulb and universal waste mail-back through our LampTracker® program; and a sharps mail return program through which individuals can safely dispose of

their used syringes and lancets using our MedWaste Tracker[®] system. In addition, we have made investments that involve acquisition and development of interests in oil and gas producing properties. Finally, we rent portable restroom facilities to municipalities and commercial customers under the name Port-o-Let[®], we service such facilities and we provide street and parking lot sweeping services.

Competition

We encounter intense competition from governmental, quasi-governmental and private sources in all aspects of our operations. In North America, the industry consists primarily of two national waste management companies, regional companies and local companies of varying sizes and financial resources, including companies that specialize in certain discrete areas of waste management, operators of alternative disposal facilities and companies that seek to use parts of the waste stream as feedstock for renewable energy and other by-products. We compete with these companies as well as with counties and municipalities that maintain their own waste collection and disposal operations.

Operating costs, disposal costs and collection fees vary widely throughout the geographic areas in which we operate. The prices that we charge are determined locally, and typically vary by volume and weight, type of waste collected, treatment requirements, risk of handling or disposal, frequency of collections, distance to final disposal sites, the availability of airspace within the geographic region, labor costs and amount and type of equipment furnished to the customer. We face intense competition in our core business based on pricing and quality of service. We have also begun competing for business based on service offerings. As companies, individuals and communities look for ways to be more sustainable, we are investing in greener technologies and promoting our comprehensive services that go beyond our core business of collecting and disposing of waste.

Seasonal Trends

Our operating revenues normally tend to be somewhat higher in the summer months, primarily due to the traditional seasonal increase in the volume of construction and demolition waste. Historically, the volumes of industrial and residential waste in certain regions in which we operate have tended to increase during the summer months. Our second and third quarter revenues and results of operations typically reflect these seasonal trends.

Additionally, certain destructive weather conditions that tend to occur during the second half of the year, such as the hurricanes that most often impact our Southern Group, can actually increase our revenues in the areas affected. While weather-related and other “one-time” occurrences can boost revenues through additional work, as a result of significant start-up costs and other factors, such revenue sometimes generates earnings at comparatively lower margins. Certain weather conditions, including severe winter storms, may result in the temporary suspension of our operations, which can significantly affect the operating results of the affected regions. The operating results of our first quarter also often reflect higher repair and maintenance expenses because we rely on the slower winter months, when waste flows are generally lower, to perform scheduled maintenance at our waste-to-energy facilities.

Employees

At December 31, 2011, we had approximately 44,300 full-time employees, of which approximately 8,300 were employed in administrative and sales positions and the balance in operations. Approximately 9,200 of our employees are covered by collective bargaining agreements.

Financial Assurance and Insurance Obligations

Financial Assurance

Municipal and governmental waste service contracts generally require contracting parties to demonstrate financial responsibility for their obligations under the contract. Financial assurance is also a requirement for obtaining or retaining disposal site or transfer station operating permits. Various forms of financial assurance are also required to support variable-rate tax-exempt debt and by regulatory agencies for estimated final capping, closure, post-closure and environmental remedial obligations at many of our landfills.

We establish financial assurance using surety bonds, letters of credit, insurance policies, trust and escrow agreements and financial guarantees. The type of assurance used is based on several factors, most importantly: the jurisdiction, contractual requirements, market factors and availability of credit capacity. The following table summarizes the various forms and dollar amounts (in millions) of financial assurance that we had outstanding as of December 31, 2011:

| | |
|---|-----------------------|
| Surety bonds: | |
| Issued by consolidated subsidiary(a) | \$ 215 |
| Issued by affiliated entity(b) | 1,003 |
| Issued by third-party surety companies | <u>1,734</u> |
| Total surety bonds | \$2,952 |
| Letters of credit: | |
| Revolving credit facility(c) | 1,012 |
| Letter of credit facilities(d) | 502 |
| Other lines of credit | <u>251</u> |
| Total letters of credit | 1,765 |
| Insurance policies: | |
| Issued by consolidated subsidiary(a) | 1,057 |
| Issued by affiliated entity(b) | 24 |
| Issued by third-party insurance companies | <u>182</u> |
| Total insurance policies | 1,263 |
| Funded trust and escrow accounts(e) | 137 |
| Financial guarantees(f) | <u>252</u> |
| Total financial assurance(g) | <u><u>\$6,369</u></u> |

-
- (a) We use surety bonds and insurance policies issued by a wholly-owned insurance subsidiary, National Guaranty Insurance Company of Vermont, the sole business of which is to issue financial assurance to WM and its subsidiaries. National Guaranty Insurance Company is authorized to write up to approximately \$1.5 billion in surety bonds or insurance policies for our final capping, closure and post-closure requirements, waste collection contracts and other business-related obligations.
- (b) We hold a noncontrolling interest in an entity that we use to obtain financial assurance. Our contractual agreement with this entity does not specifically limit the amounts of surety bonds or insurance that we may obtain, making our financial assurance under this agreement limited only by the guidelines and restrictions of surety and insurance regulations.
- (c) WM has a \$2.0 billion revolving credit facility with a term ending May 2016. At December 31, 2011, we had \$150 million of outstanding borrowings and \$1,012 million of letters of credit issued and supported by the facility. The unused and available credit capacity of the facility was \$838 million as of December 31, 2011.
- (d) We have an aggregate committed capacity of \$505 million under letter of credit facilities with terms ending from June 2013 to June 2015. As of December 31, 2011, no borrowings were outstanding under these letter of credit facilities and we had \$3 million of unused or available credit capacity.
- (e) Our funded trust and escrow accounts generally have been established to support landfill final capping, closure, post-closure and environmental remediation obligations and our performance under various operating contracts. Balances maintained in these trust funds and escrow accounts will fluctuate based on (i) changes in statutory requirements; (ii) future deposits made to comply with contractual arrangements; (iii) the ongoing use of funds for qualifying activities; (iv) acquisitions or divestitures of landfills; and (v) changes in the fair value of the financial instruments held in the trust fund or escrow accounts. The assets held in our funded trust and escrow accounts may be drawn and used to meet the obligations for which the trusts and escrows were established.

- (f) WM provides financial guarantees on behalf of its subsidiaries to municipalities, customers and regulatory authorities. They are provided primarily to support our performance of landfill final capping, closure and post-closure activities.
- (g) The amount of financial assurance required can, and generally will, differ from the obligation determined and recorded under accounting principles generally accepted in the U.S.

Virtually no claims have been made against our financial assurance instruments in the past, and considering our current financial position, management does not expect there to be claims against these instruments that will have a material adverse effect on our Consolidated Financial Statements.

Insurance

We carry a broad range of insurance coverages, including general liability, automobile liability, real and personal property, workers' compensation, directors' and officers' liability, pollution legal liability and other coverages we believe are customary to the industry. Our exposure to loss for insurance claims is generally limited to the per incident deductible under the related insurance policy. As of December 31, 2011, our general liability insurance program carried self-insurance exposures of up to \$2.5 million per incident and our workers' compensation insurance program carried self-insurance exposures of up to \$5 million per incident. As of December 31, 2011, our auto liability insurance program included a per incident base deductible of \$5 million, subject to additional deductibles of \$4.8 million in the \$5 million to \$10 million layer. We do not expect the impact of any known casualty, property, environmental or other contingency to have a material impact on our financial condition, results of operations or cash flows. Our estimated insurance liabilities as of December 31, 2011 are summarized in Note 11 to the Consolidated Financial Statements.

The Directors' and Officers' Liability Insurance policy we choose to maintain covers only individual executive liability, often referred to as "Broad Form Side A," and does not provide corporate reimbursement coverage, often referred to as "Side B." The Side A policy covers directors and officers directly for loss, including defense costs, when corporate indemnification is unavailable. Side A-only coverage cannot be exhausted by payments to the Company, as the Company is not insured for any money it advances for defense costs or pays as indemnity to the insured directors and officers.

Regulation

Our business is subject to extensive and evolving federal, state or provincial and local environmental, health, safety and transportation laws and regulations. These laws and regulations are administered by the U.S. EPA, Environment Canada, and various other federal, state and local environmental, zoning, transportation, land use, health and safety agencies in the United States and Canada. Many of these agencies regularly examine our operations to monitor compliance with these laws and regulations and have the power to enforce compliance, obtain injunctions or impose civil or criminal penalties in case of violations. In recent years, we have perceived an increase in both the amount of government regulation and the number of enforcement actions being brought by regulatory entities against operations in the waste services industry. We expect this heightened governmental focus on regulation and enforcement to continue.

Because the major component of our business is the collection and disposal of solid waste in an environmentally sound manner, a significant amount of our capital expenditures are related, either directly or indirectly, to environmental protection measures, including compliance with federal, state or provincial and local provisions that regulate the placement of materials into the environment. There are costs associated with siting, design, operations, monitoring, site maintenance, corrective actions, financial assurance, and facility closure and post-closure obligations. In connection with our acquisition, development or expansion of a disposal facility or transfer station, we must often spend considerable time, effort and money to obtain or maintain required permits and approvals. There cannot be any assurances that we will be able to obtain or maintain required governmental approvals. Once obtained, operating permits are subject to renewal, modification, suspension or revocation by the issuing agency. Compliance with these and any future regulatory requirements could require us to make significant capital and operating expenditures. However, most of these expenditures are made in the normal course of business and do not place us at any competitive disadvantage.

The primary United States federal statutes affecting our business are summarized below:

- The Resource Conservation and Recovery Act of 1976, as amended, regulates handling, transporting and disposing of hazardous and non-hazardous waste and delegates authority to states to develop programs to ensure the safe disposal of solid waste. In 1991, the EPA issued its final regulations under Subtitle D of RCRA, which set forth minimum federal performance and design criteria for solid waste landfills. These regulations are typically implemented by the states, although states can impose requirements that are more stringent than the Subtitle D standards. We incur costs in complying with these standards in the ordinary course of our operations.
- The Comprehensive Environmental Response, Compensation and Liability Act of 1980, as amended, which is also known as Superfund, provides for federal authority to respond directly to releases or threatened releases of hazardous substances into the environment that have created actual or potential environmental hazards. CERCLA's primary means for addressing such releases is to impose strict liability for cleanup of disposal sites upon current and former site owners and operators, generators of the hazardous substances at the site and transporters who selected the disposal site and transported substances thereto. Liability under CERCLA is not dependent on the intentional disposal of hazardous substances; it can be based upon the release or threatened release, even as a result of lawful, unintentional and non-negligent action, of hazardous substances as the term is defined by CERCLA and other applicable statutes and regulations. Liability may include contribution for cleanup costs incurred by a defendant in a CERCLA civil action or by an entity that has previously resolved its liability to federal or state regulators in an administrative or judicially-approved settlement. Liability under CERCLA could also include obligations to a PRP that voluntarily expends site clean-up costs. Further, liability for damage to publicly-owned natural resources may also be imposed. We are subject to potential liability under CERCLA as an owner or operator of facilities at which hazardous substances have been disposed and as a generator or transporter of hazardous substances disposed of at other locations.
- The Federal Water Pollution Control Act of 1972, known as the Clean Water Act, regulates the discharge of pollutants into streams, rivers, groundwater, or other surface waters from a variety of sources, including solid and hazardous waste disposal sites. If run-off from our operations may be discharged into surface waters, the Clean Water Act requires us to apply for and obtain discharge permits, conduct sampling and monitoring, and, under certain circumstances, reduce the quantity of pollutants in those discharges. In 1990, the EPA issued additional standards for management of storm water runoff that require landfills and other waste-handling facilities to obtain storm water discharge permits. In addition, if a landfill or other facility discharges wastewater through a sewage system to a publicly-owned treatment works, the facility must comply with discharge limits imposed by the treatment works. Also, before the development or expansion of a landfill can alter or affect "wetlands," a permit may have to be obtained providing for mitigation or replacement wetlands. The Clean Water Act provides for civil, criminal and administrative penalties for violations of its provisions.
- The Clean Air Act of 1970, as amended, provides for increased federal, state and local regulation of the emission of air pollutants. Certain of our operations are subject to the requirements of the Clean Air Act, including large municipal solid waste landfills and large municipal waste-to-energy facilities. Standards have also been imposed on manufacturers of transportation vehicles (including waste collection vehicles). In 1996 the EPA issued new source performance standards and emission guidelines controlling landfill gases from new and existing large landfills. In January 2003, the EPA issued Maximum Achievable Control Technology standards for municipal solid waste landfills subject to the new source performance standards. These regulations impose limits on air emissions from large municipal solid waste landfills, subject most of our large municipal solid waste landfills to certain operating permit requirements under Title V of the Clean Air Act and, in many instances, require installation of landfill gas collection and control systems to control emissions or to treat and utilize landfill gas on- or off-site.

The EPA has issued new source performance standards and emission guidelines for large and small municipal waste-to-energy facilities, which include stringent emission limits for various pollutants based on Maximum Achievable Control Technology standards. These sources are also subject to operating permit requirements under Title V of the Clean Air Act. The Clean Air Act requires the EPA to review and revise the MACT standards applicable to municipal waste-to-energy facilities every five years.

- The Occupational Safety and Health Act of 1970, as amended, establishes certain employer responsibilities, including maintenance of a workplace free of recognized hazards likely to cause death or serious injury, compliance with standards promulgated by the Occupational Safety and Health Administration, and various reporting and record keeping obligations as well as disclosure and procedural requirements. Various standards for notices of hazards, safety in excavation and demolition work and the handling of asbestos, may apply to our operations. The Department of Transportation and OSHA, along with other federal agencies, have jurisdiction over certain aspects of hazardous materials and hazardous waste, including safety, movement and disposal. Various state and local agencies with jurisdiction over disposal of hazardous waste may seek to regulate movement of hazardous materials in areas not otherwise preempted by federal law.

We are also actively monitoring the following recent developments in United States federal statutes affecting our business:

- In 2010, the EPA issued the Prevention of Significant Deterioration, or PSD, and Title V Greenhouse Gas, or GHG, Tailoring Rule which expanded the EPA's federal air permitting authority to include the six GHGs, including methane and carbon dioxide. Air permits for new and modified large municipal solid waste landfills, waste-to-energy facilities and landfill gas-to-energy facilities could be impacted, but the degree of impact is incumbent upon the EPA's final determination on permitting of biogenic GHG emissions (e.g. carbon dioxide) as well as the EPA's or implementing states' determinations on what may constitute "Best Available Control Technology" for new projects exceeding certain thresholds. In addition, recent final and proposed reductions in certain National Ambient Air Quality Standards and related PSD increment/significance thresholds could impact the cost, timeliness and availability of air permits for new and modified large municipal solid waste landfills, waste-to-energy facilities and landfill gas-to-energy facilities. In general, controlling emissions involves drilling collection wells into a landfill and routing the gas to a suitable energy recovery system or combustion device. The landfill gas at 131 of our solid waste landfills is currently being captured and utilized for its renewable energy value. Efforts to curtail the emission of greenhouse gases and to ameliorate the effect of climate change may require our landfills to deploy more stringent emission controls, with resulting capital or operating costs; however, we do not believe that such regulations will have a material adverse impact on our business as a whole. See Item 1A. *Risk Factors* — "The adoption of climate change legislation or regulations restricting emissions of "greenhouse gases" could increase our costs to operate."
- In 2011, the EPA published the Non-Hazardous Secondary Materials, or NHSM, Rule, which provides the standards and procedures for identifying whether NHSM are solid waste under RCRA when used as fuels or ingredients in combustion units. The EPA also published new source performance standards and emission guidelines for commercial and industrial solid waste incineration units, and Maximum Achievable Control Technology Standards for commercial and industrial boilers. The EPA has published clarifications and is currently considering amendments to these rules. In addition, there is litigation surrounding the rules and there is proposed legislation seeking to delay implementation and revise the requirements. Some of the potential regulatory outcomes could have a significant impact on some of our projects in which we are seeking to convert biomass or other secondary materials into products, fuels or energy, as well as some of our landfill gas to energy and biomass to energy projects. It is not possible to quantify the financial impact of these rulemakings, which are being reconsidered at this time. However, we do not believe the rules will have a material adverse impact on our business as a whole.

There are also various state or provincial and local regulations that affect our operations. Each state and province in which we operate has its own laws and regulations governing solid waste disposal, water and air pollution, and, in most cases, releases and cleanup of hazardous substances and liabilities for such matters. States and provinces have also adopted regulations governing the design, operation, maintenance and closure of landfills and transfer stations. Some counties, municipalities and other local governments have adopted similar laws and regulations. Our facilities and operations are likely to be subject to these types of requirements.

In addition, our landfill and waste-to-energy operations are affected by the increasing preference for alternatives to landfill and waste-to-energy disposal. Several state and local governments mandate recycling and waste reduction at the source and prohibit the disposal of certain types of waste, such as yard and food waste, at

landfills or waste-to-energy facilities. Legislative and regulatory measures to mandate or encourage waste reduction at the source and waste recycling also have been or are under consideration by the U.S. Congress and the EPA.

Various states have enacted, or are considering enacting, laws that restrict the disposal within the state of solid waste generated outside the state. While laws that overtly discriminate against out-of-state waste have been found to be unconstitutional, some laws that are less overtly discriminatory have been upheld in court. Additionally, several state and local governments have enacted “flow control” regulations, which attempt to require that all waste generated within the state or local jurisdiction be deposited at specific sites. In 1994, the United States Supreme Court ruled that a flow control ordinance that gave preference to a local facility that was privately owned was unconstitutional, but in 2007, the Court ruled that an ordinance directing waste to a facility owned by the local government was constitutional. In addition, from time to time, the United States Congress has considered legislation authorizing states to adopt regulations, restrictions, or taxes on the importation of out-of-state or out-of-jurisdiction waste. The United States Congress’ adoption of legislation allowing restrictions on interstate transportation of out-of-state or out-of-jurisdiction waste or certain types of flow control or the adoption of legislation affecting interstate transportation of waste at the state level could adversely affect our operations. Courts’ interpretation of flow control legislation or the Supreme Court decisions also could adversely affect our solid and hazardous waste management services.

Many states, provinces and local jurisdictions have enacted “fitness” laws that allow the agencies that have jurisdiction over waste services contracts or permits to deny or revoke these contracts or permits based on the applicant’s or permit holder’s compliance history. Some states, provinces and local jurisdictions go further and consider the compliance history of the parent, subsidiaries or affiliated companies, in addition to the applicant or permit holder. These laws authorize the agencies to make determinations of an applicant’s or permit holder’s fitness to be awarded a contract to operate, and to deny or revoke a contract or permit because of unfitness, unless there is a showing that the applicant or permit holder has been rehabilitated through the adoption of various operating policies and procedures put in place to assure future compliance with applicable laws and regulations.

See Note 11 to the Consolidated Financial Statements for disclosures relating to our current assessments of the impact of regulations on our current and future operations.

Item 1A. Risk Factors.

In an effort to keep our stockholders and the public informed about our business, we may make “forward-looking statements.” Forward-looking statements usually relate to future events and anticipated revenues, earnings, cash flows or other aspects of our operations or operating results. Forward-looking statements are often identified by the words, “will,” “may,” “should,” “continue,” “anticipate,” “believe,” “expect,” “plan,” “forecast,” “project,” “estimate,” “intend” and words of similar nature and generally include statements containing:

- projections about accounting and finances;
- plans and objectives for the future;
- projections or estimates about assumptions relating to our performance; or
- our opinions, views or beliefs about the effects of current or future events, circumstances or performance.

You should view these statements with caution. These statements are not guarantees of future performance, circumstances or events. They are based on facts and circumstances known to us as of the date the statements are made. All aspects of our business are subject to uncertainties, risks and other influences, many of which we do not control. Any of these factors, either alone or taken together, could have a material adverse effect on us and could change whether any forward-looking statement ultimately turns out to be true. Additionally, we assume no obligation to update any forward-looking statement as a result of future events, circumstances or developments. The following discussion should be read together with the Consolidated Financial Statements and the notes thereto. Outlined below are some of the risks that we believe could affect our business and financial statements for 2012 and beyond and that could cause actual results to be materially different from those that may be set forth in forward-looking statements made by the Company.

The waste industry is highly competitive, and if we cannot successfully compete in the marketplace, our business, financial condition and operating results may be materially adversely affected.

We encounter intense competition from governmental, quasi-governmental and private sources in all aspects of our operations. In North America, the industry consists primarily of two national waste management companies, regional companies and local companies of varying sizes and financial resources, including companies that specialize in certain discrete areas of waste management, operators of alternative disposal facilities and companies that seek to use parts of the waste stream as feedstock for renewable energy and other by products. We compete with these companies as well as with counties and municipalities that maintain their own waste collection and disposal operations. These counties and municipalities may have financial competitive advantages because tax revenues are available to them and tax-exempt financing is more readily available to them. Also, such governmental units may attempt to impose flow control or other restrictions that would give them a competitive advantage. In addition, competitors may reduce their prices to expand sales volume or to win competitively-bid contracts, including large national accounts and exclusive franchise arrangements with municipalities. When this happens, we may lose customers and be unable to execute our pricing strategy, resulting in a negative impact to our revenue growth from yield on base business.

If we fail to implement our business strategy, our financial performance and our growth could be materially and adversely affected.

Our future financial performance and success are dependent in large part upon our ability to implement our business strategy successfully. Implementation of our strategy will require effective management of our operational, financial and human resources and will place significant demands on those resources. We have adopted a business strategy built on three key initiatives: know more about our customers and how to service them than anyone else; use conversion and processing technology to extract more value from the materials we manage; and continuously improve our operational efficiency. In the short-term, we intend to pursue these initiatives through efforts to:

- Grow our markets by implementing customer-focused growth, through customer segmentation and through strategic acquisitions, while maintaining our pricing discipline and increasing the amount of recyclable materials we manage each year;
- Grow our customer loyalty;
- Grow into new markets by investing in greener technologies; and
- Pursue initiatives that improve our operations and cost structure.

There are risks involved in pursuing our strategy, including the following:

- Our strategy may result in a significant change to our business, and our employees, customers or investors may not embrace and support our strategy.
- We may not be able to hire or retain the personnel necessary to manage our strategy effectively.
- Customer segmentation is new to our business, and it could result in fragmentation of our efforts, rather than improved customer relationships.
- In efforts to enhance our revenues, we have implemented price increases and environmental fees, and we have continued our fuel surcharge program to offset fuel costs. The loss of volumes as a result of price increases may negatively affect our cash flows or results of operations.
- We may be unsuccessful in implementing improvements to operational efficiency and such efforts may not yield the intended result.
- Our ability to make strategic acquisitions and invest in greener technologies depends on our ability to identify desirable acquisition or investment targets, negotiate advantageous transactions despite competition for such opportunities, fund such acquisitions on favorable terms, and realize the benefits we expect from those transactions.

- Acquisitions, investments and/or new service offerings may not increase our earnings in the timeframe anticipated, or at all, due to difficulties operating in new markets or providing new service offerings, failure to operate within budget, integration issues, or regulatory issues, among others.
- Integration of acquisitions, investments and/or new services offerings could increase our exposure to the risk of inadvertent noncompliance with applicable laws and regulations.
- Execution of our strategy may cause us to incur substantial research and development costs and/or additional indebtedness, which may divert capital away from our traditional business operations.
- We continue to seek to divest underperforming and non-strategic assets if we cannot improve their profitability. We may not be able to successfully negotiate the divestiture of underperforming and non-strategic operations, which could result in asset impairments or the continued operation of low-margin businesses.

In addition to the risks set forth above, implementation of our business strategy could also be affected by a number of factors beyond our control, such as increased competition, legal developments, government regulation, general economic conditions, increased operating costs or expenses and changes in industry trends. Further, we may decide to alter or discontinue certain aspects of our business strategy at any time. If we are not able to implement our business strategy successfully, our long-term growth and profitability may be adversely affected. Even if we are able to implement some or all of the initiatives of our business plan successfully, our operating results may not improve to the extent we anticipate, or at all.

The waste industry is subject to extensive government regulation; existing or future regulations and/or enforcement actions may restrict our operations, increase our costs of operations or require us to make additional capital expenditures.

Stringent government regulations at the federal, state, provincial, and local level in the United States and Canada have a substantial impact on our business, and compliance with such regulations is costly. A large number of complex laws, rules, orders and interpretations govern environmental protection, health, safety, land use, zoning, transportation and related matters. In recent years, we have perceived an increase in both the amount of government regulation and the number of enforcement actions being brought by regulatory entities against operations, in the waste services industry. We expect this heightened governmental focus on regulation and enforcement to continue. Among other things, governmental regulations and enforcement actions may restrict our operations and adversely affect our financial condition, results of operations and cash flows by imposing conditions such as:

- limitations on siting and constructing new waste disposal, transfer or processing facilities or on expanding existing facilities;
- limitations, regulations or levies on collection and disposal prices, rates and volumes;
- limitations or bans on disposal or transportation of out-of-state waste or certain categories of waste; or
- mandates regarding the disposal of solid waste, including requirements to recycle rather than landfill certain waste streams.

Regulations affecting the siting, design and closure of landfills could require us to undertake investigatory or remedial activities, curtail operations or close landfills temporarily or permanently. Future changes in these regulations may require us to modify, supplement or replace equipment or facilities. The costs of complying with these regulations could be substantial.

In order to develop, expand or operate a landfill or other waste management facility, we must have various facility permits and other governmental approvals, including those relating to zoning, environmental protection and land use. The permits and approvals are often difficult, time consuming and costly to obtain and could contain conditions that limit our operations.

We also have significant financial obligations relating to final capping, closure, post-closure and environmental remediation at our existing landfills. We establish accruals for these estimated costs, but we could underestimate such accruals. Environmental regulatory changes could accelerate or increase capping, closure, post-closure and remediation costs, requiring our expenditures to materially exceed our current accruals.

Various states have enacted, or are considering enacting, laws that restrict the disposal within the state of solid waste generated outside the state. Additionally, several state and local governments have enacted “flow control” regulations, which attempt to require that all waste generated within the state or local jurisdiction be deposited at specific sites. The United States Congress’ adoption of legislation allowing restrictions on interstate transportation of out-of-state or out-of-jurisdiction waste or certain types of flow control or the adoption of legislation affecting interstate transportation of waste at the state level could adversely affect our operations. Courts’ interpretation of flow control legislation or the Supreme Court decisions also could adversely affect our solid and hazardous waste management services.

Our revenues will fluctuate based on changes in commodity prices.

Our recycling operations process for sale certain recyclable materials, including fibers, aluminum and glass, all of which are subject to significant market price fluctuations. The majority of the recyclables that we process for sale are paper fibers, including old corrugated cardboard and old newsprint. The fluctuations in the market prices or demand for these commodities, particularly demand from Chinese paper mills, can affect our operating income and cash flows negatively, as we experienced in 2009, or positively, as we experienced in 2010 and 2011. As we have increased the size of our recycling operations, we have also increased our exposure to commodity price fluctuations. The decline in market prices in 2009 for commodities resulted in a year-over-year decrease in revenue of \$447 million compared with 2008. Increases in the prices of recycling commodities resulted in year-over-year increases in revenue of \$423 million and \$216 million in 2010 and 2011, respectively. Market prices for recyclable commodities have increased significantly from the near-historic lows experienced in late 2008 and early 2009. Overall commodity prices have increased year-over-year approximately 57% and 18% in 2010 and 2011, respectively. Despite the recent positive trend in commodity prices, these prices may fluctuate substantially and without notice in the future. Additionally, our recycling operations offer rebates to suppliers. Therefore, even if we experience higher revenues based on increased market prices for commodities, the rebates we pay will also increase. In other circumstances, the rebates may be subject to a floor, such that as market prices decrease, any expected profit margins on materials subject to the rebate floor are eliminated.

There are also significant price fluctuations in the price of methane gas, electricity and other energy-related products that are marketed and sold by our landfill gas recovery, waste-to-energy and independent power production plant operations that can significantly impact our revenue from yield provided by such businesses. In most of the markets in which we operate, electricity prices correlate with natural gas prices. During the years ended December 31, 2011, 2010 and 2009, approximately 54%, 47% and 46%, respectively, of the electricity revenue at our waste-to-energy facilities was subject to current market rates. Our waste-to-energy facilities’ exposure to market price volatility will continue to increase as additional long-term contracts expire. We cannot assure you that we will be able to enter into renewal contracts on comparable or favorable terms, or at all. To mitigate a portion of the variability in our revenues and cash flows caused by fluctuations in the market prices for electricity, we use “receive fixed, pay variable” electricity swaps. These swaps are generally short-term in nature. Additionally, revenues from our independent power production plants can be affected by price fluctuations. If we are unable to successfully negotiate long-term contracts, or if market prices are at lower levels for sustained periods, our revenues could be adversely affected.

Increasing customer preference for alternatives to landfill disposal and waste-to-energy facilities could reduce our ability to operate at full capacity and cause our revenues and operating results to decline.

Our customers are increasingly diverting waste to alternatives to landfill and waste-to-energy disposal, such as recycling and composting, while also working to reduce the amount of waste they generate. In addition, several state and local governments mandate recycling and waste reduction at the source and prohibit the disposal of certain types of waste, such as yard and food waste, at landfills or waste-to-energy facilities. Where such organic waste is not banned from the landfill or waste-to-energy facility, large customers such as grocery stores and restaurants are choosing to divert their organic waste from landfills. Zero-waste goals (sending no waste to the landfill) have been set by many of North America’s largest companies. Although such mandates and initiatives help to protect our environment, these developments reduce the volume of waste going to landfills and waste-to-energy facilities in certain areas, which may affect our ability to operate our landfills and waste-to-energy facilities at full capacity, as well as affecting the prices that we can charge for landfill disposal

and waste-to-energy services. Our landfills and our waste-to-energy facilities currently provide and have historically provided our highest operating margins. If we are not successful in expanding our service offerings and growing lines of businesses to service waste streams that do not go to landfills or waste-to-energy facilities and to provide services for customers that wish to reduce waste entirely, then our revenues and operating results will decline. Additionally, despite the development of new service offerings and lines of business, it is reasonably possible that our revenues and our operating margins could be negatively affected due to disposal alternatives.

Developments in technology could trigger a fundamental change in the waste management industry, as waste streams are increasingly viewed as a resource, which may adversely impact volumes at our landfills and waste-to-energy facilities and our profitability.

Our company and others have recognized the value of the traditional waste stream as a potential resource. Research and development activities are on-going to provide disposal alternatives that maximize the value of waste, including using waste as a source for renewable energy and other valuable by-products. We and many other companies are investing in these technologies. It is possible that such investments and technological advancements may reduce the cost of waste disposal or power production to a level below our costs and may reduce the demand for landfill space and waste-to-energy facilities. As a result, our revenues and operating margins could be adversely affected due to advancements in disposal alternatives.

If we are not able to develop new service offerings and protect intellectual property, or if a competitor develops or obtains exclusive rights to a breakthrough technology, our financial results may suffer.

Our existing and proposed service offerings to customers may require that we invest in, develop or license, and protect, new technologies. Research and development of new technologies often requires significant spending that may divert capital investment away from our traditional business operations. We may experience difficulties or delays in the research, development, production and/or marketing of new products and services which may negatively impact our operating results and prevent us from recouping or realizing a return on the investments required to bring new products and services to market. Further, protecting our intellectual property rights and combating unlicensed copying and use of intellectual property is difficult, and any inability to obtain or protect new technologies could impact our services to customers and development of new revenue sources. Our Company and others are increasingly focusing on new technologies that provide alternatives to traditional disposal and maximize the resource value of waste. If a competitor develops or obtains exclusive rights to a “breakthrough technology” that provides a revolutionary change in traditional waste management, or if we have inferior intellectual property to our competitors, our financial results may suffer.

Our business depends on our reputation and the value of our brand.

We believe we have developed a reputation for high-quality service, reliability and social and environmental responsibility, and we believe our brand symbolizes these attributes. The Waste Management brand name, trademarks and logos and our reputation are powerful sales and marketing tools, and we devote significant resources to promoting and protecting them. Adverse publicity, whether or not justified, relating to activities by our operations, employees or agents could tarnish our reputation and reduce the value of our brand. Damage to our reputation and loss of brand equity could reduce demand for our services. This reduction in demand, together with the dedication of time and expense necessary to defend our reputation, could have an adverse effect on our financial condition, liquidity and results of operations, as well as require additional resources to rebuild our reputation and restore the value of our brand.

Our operations are subject to environmental, health and safety laws and regulations, as well as contractual obligations that may result in significant liabilities.

There is risk of incurring significant environmental liabilities in the use, treatment, storage, transfer and disposal of waste materials. Under applicable environmental laws and regulations, we could be liable if our operations cause environmental damage to our properties or to the property of other landowners, particularly as a result of the contamination of air, drinking water or soil. Under current law, we could also be held liable for damage caused by conditions that existed before we acquired the assets or operations involved. This risk is of

particular concern as we execute our growth strategy, partially through acquisitions, because we may be unsuccessful in identifying and assessing potential liabilities during our due diligence investigations. Further, the counterparties in such transactions may be unable to perform their indemnification obligations owed to us. Additionally, we could be liable if we arrange for the transportation, disposal or treatment of hazardous substances that cause environmental contamination, or if a predecessor owner made such arrangements and, under applicable law, we are treated as a successor to the prior owner. Any substantial liability for environmental damage could have a material adverse effect on our financial condition, results of operations and cash flows.

In the ordinary course of our business, we have in the past, we are currently, and we may in the future, become involved in legal and administrative proceedings relating to land use and environmental laws and regulations. These include proceedings in which:

- agencies of federal, state, local or foreign governments seek to impose liability on us under applicable statutes, sometimes involving civil or criminal penalties for violations, or to revoke or deny renewal of a permit we need; and
- local communities, citizen groups, landowners or governmental agencies oppose the issuance of a permit or approval we need, allege violations of the permits under which we operate or laws or regulations to which we are subject, or seek to impose liability on us for environmental damage.

We generally seek to work with the authorities or other persons involved in these proceedings to resolve any issues raised. If we are not successful, the adverse outcome of one or more of these proceedings could result in, among other things, material increases in our costs or liabilities as well as material charges for asset impairments.

Further, we often enter into contractual arrangements with landowners imposing obligations on us to meet certain regulatory or contractual conditions upon site closure or upon termination of the agreements. Compliance with these arrangements is inherently subject to subjective determinations and may result in disputes, including litigation. Costs to remediate or restore the condition of closed sites may be significant.

General economic conditions can directly and adversely affect our revenues and our operating margins.

Our business is directly affected by changes in national and general economic factors that are outside of our control, including consumer confidence, interest rates and access to capital markets. A weak economy generally results in decreased consumer spending and decreases in volumes of waste generated, which decreases our revenues. In addition, we have a relatively high fixed-cost structure, which is difficult to quickly adjust to match shifting volume levels. Consumer uncertainty and the loss of consumer confidence may limit the number or amount of services requested by customers and our ability to implement our pricing strategy. Economic conditions may also limit our ability to implement our pricing strategy. For example, many of our contracts have price adjustment provisions that are tied to an index such as the Consumer Price Index, and our costs may increase in excess of the increase, if any, in the Consumer Price Index.

Some of our customers, including governmental entities, have suffered financial difficulties affecting their credit risk, which could negatively impact our operating results.

We provide service to a number of governmental entities and municipalities, some of which have suffered significant financial difficulties due to the downturn in the U.S. economy and reduced tax revenue. Some of these entities could be unable to pay amounts owed to us or renew contracts with us at previous or increased rates.

Many non-governmental customers have also suffered serious financial difficulties, including bankruptcy in some cases. Purchasers of our recyclable commodities can be particularly vulnerable to financial difficulties in times of commodity price volatility. The inability of our customers to pay us in a timely manner or to pay increased rates, particularly large national accounts, could negatively affect our operating results.

In addition, the financial difficulties of municipalities could result in a decline in investors' demand for municipal bonds and a correlating increase in interest rates. As of December 31, 2011, we had \$611 million of tax-exempt bonds that are subject to re-pricing on either a daily or a weekly basis through a remarketing process and \$305 million of tax-exempt bonds with term interest rate periods that are subject to re-pricing within the next twelve months. If the weakness in the municipal debt market results in re-pricing of our tax-exempt bonds at significantly higher interest rates, we will incur increased interest expenses that may negatively affect our operating results and cash flows.

We may be unable to obtain or maintain required permits or to expand existing permitted capacity of our landfills, which could decrease our revenue and increase our costs.

Our ability to meet our financial and operating objectives depends in part on our ability to obtain and maintain the permits necessary to operate landfill sites. Permits to build, operate and expand solid waste management facilities, including landfills and transfer stations, have become more difficult and expensive to obtain and maintain. Permits often take years to obtain as a result of numerous hearings and compliance requirements with regard to zoning, environmental and other regulations. These permits are also often subject to resistance from citizen or other groups and other political pressures. Local communities and citizen groups, adjacent landowners or governmental agencies may oppose the issuance of a permit or approval we may need, allege violations of the permits under which we currently operate or laws or regulations to which we are subject, or seek to impose liability on us for environmental damage. Responding to these challenges has, at times, increased our costs and extended the time associated with establishing new facilities and expanding existing facilities. In addition, failure to receive regulatory and zoning approval may prohibit us from establishing new facilities or expanding existing facilities. Our failure to obtain the required permits to operate our landfills could have a material adverse impact on our consolidated financial condition, results of operations and cash flows.

Significant shortages in fuel supply or increases in fuel prices will increase our operating expenses.

The price and supply of fuel can fluctuate significantly based on international, political and economic circumstances, as well as other factors outside our control, such as actions by the Organization of the Petroleum Exporting Countries, or OPEC, and other oil and gas producers, regional production patterns, weather conditions and environmental concerns. We have seen average quarterly fuel prices increase by as much as 33% on a year-over-year basis and decrease by as much as 47% on a year-over-year basis within the last three years. We need fuel to run our collection and transfer trucks and our equipment used in our landfill operations. Supply shortages could substantially increase our operating expenses. Additionally, as fuel prices increase, our direct operating expenses increase and many of our vendors raise their prices as a means to offset their own rising costs. We have in place a fuel surcharge program, designed to offset increased fuel expenses; however, we may not be able to pass through all of our increased costs and some customers' contracts prohibit any pass-through of the increased costs. Additionally, we are currently party to a pending litigation that pertains to our fuel and environmental charge and generally alleges that such charges were not properly disclosed, were unfair, and were contrary to contract. See Note 11 of the Consolidated Financial Statements for more information. Regardless of any offsetting surcharge programs, the increased operating costs will decrease our operating margins.

We are increasingly dependent on technology in our operations and if our technology fails, our business could be adversely affected.

We may experience problems with the operation of our current information technology systems or the technology systems of third parties on which we rely, as well as the development and deployment of new information technology systems, that could adversely affect, or even temporarily disrupt, all or a portion of our operations until resolved. Inabilities and delays in implementing new systems can also affect our ability to realize projected or expected cost savings. Additionally, any systems failures could impede our ability to timely collect and report financial results in accordance with applicable laws and regulations.

A cybersecurity incident could negatively impact our business and our relationships with customers.

We use computers in substantially all aspects of our business operations. We also use mobile devices, social networking and other online activities to connect with our employees and our customers. Such uses give rise to cybersecurity risks, including security breach, espionage, system disruption, theft and inadvertent release of information. Our business involves the storage and transmission of numerous classes of sensitive and/or confidential information and intellectual property, including customers' personal information, private information about employees, and financial and strategic information about the Company and its business partners. We also rely on a Payment Card Industry compliant third party to protect our customers' credit card information. Further, as the Company pursues its strategy to grow through acquisitions and to pursue new initiatives that improve our operations and cost structure, the Company is also expanding and improving its

information technologies, resulting in a larger technological presence and corresponding exposure to cybersecurity risk. If we fail to assess and identify cybersecurity risks associated with acquisitions and new initiatives, we may become increasingly vulnerable to such risks. Additionally, while we have implemented measures to prevent security breaches and cyber incidents, our preventative measures and incident response efforts may not be entirely effective. The theft, destruction, loss, misappropriation, or release of sensitive and/or confidential information or intellectual property, or interference with our information technology systems or the technology systems of third parties on which we rely, could result in business disruption, negative publicity, brand damage, violation of privacy laws, loss of customers, potential liability and competitive disadvantage.

Our operating expenses could increase as a result of labor unions organizing or changes in regulations related to labor unions.

Labor unions continually attempt to organize our employees, and these efforts will likely continue in the future. Certain groups of our employees are currently represented by unions, and we have negotiated collective bargaining agreements with these unions. Additional groups of employees may seek union representation in the future, and, if successful, the negotiation of collective bargaining agreements could divert management attention and result in increased operating expenses and lower net income. If we are unable to negotiate acceptable collective bargaining agreements, our operating expenses could increase significantly as a result of work stoppages, including strikes. Any of these matters could adversely affect our financial condition, results of operations and cash flows.

We could face significant liabilities for withdrawal from multiemployer pension plans.

We have participated in and contributed to various “multiemployer” pension plans administered by employer and union trustees. In renegotiation of collective bargaining agreements with labor unions that participate in these plans, we may decide to discontinue participation in various plans. When we withdraw from plans, we can incur withdrawal liabilities for those plans that have underfunded pension liabilities. Various factors affect our liabilities for a plan’s underfunded status, including the numbers of retirees and active workers in the plan, the ongoing solvency of participating employers, the investment returns obtained on plan assets, and the ratio of our historical participation in such plan to all employers’ historical participation. We reflect any withdrawal liability as an operating expense in our statement of operations and as a liability on our balance sheet.

We have previously withdrawn several employee bargaining units from underfunded multiemployer pension plans, and we recognized related expenses of \$26 million in 2010 and \$9 million in 2009. We are still negotiating and litigating final resolutions of our withdrawal liability for these previous withdrawals, which could be materially higher than the charges we have recognized.

Our business is subject to operational and safety risks, including the risk of personal injury to employees and others.

Provision of environmental and waste management services involves risks such as truck accidents, equipment defects, malfunctions and failures, and natural disasters, which could potentially result in releases of hazardous materials, injury or death of employees and others, or a need to shut down or reduce operation of our facilities while remedial actions are undertaken. These risks expose us to potential liability for pollution and other environmental damages, personal injury, loss of life, business interruption, and property damage or destruction.

While we seek to minimize our exposure to such risks through comprehensive training and compliance programs, as well as vehicle and equipment maintenance programs, if we were to incur substantial liabilities in excess of any applicable insurance, our business, results of operations and financial condition could be adversely affected.

We have substantial financial assurance and insurance requirements, and increases in the costs of obtaining adequate financial assurance, or the inadequacy of our insurance coverages, could negatively impact our liquidity and increase our liabilities.

The amount of insurance we are required to maintain for environmental liability is governed by statutory requirements. We believe that the cost for such insurance is high relative to the coverage it would provide and, therefore, our coverages are generally maintained at the minimum statutorily-required levels. We face the risk of incurring additional costs for environmental damage if our insurance coverage is ultimately inadequate to cover those damages. We also carry a broad range of other insurance coverages that are customary for a company our size. We use these programs to mitigate risk of loss, thereby enabling us to manage our self-insurance exposure associated with claims. The inability of our insurers to meet their commitments in a timely manner and the effect of significant claims or litigation against insurance companies may subject us to additional risks. To the extent our insurers were unable to meet their obligations, or our own obligations for claims were more than we estimated, there could be a material adverse effect to our financial results.

In addition, to fulfill our financial assurance obligations with respect to variable-rate tax-exempt debt, final capping, closure, post-closure and environmental remediation obligations, we generally obtain letters of credit or surety bonds, rely on insurance, including captive insurance, fund trust and escrow accounts or rely upon WM financial guarantees. We currently have in place all financial assurance instruments necessary for our operations. General economic factors may adversely affect the cost of our current financial assurance instruments and changes in regulations may impose stricter requirements on the types of financial assurance that will be accepted. Additionally, in the event we are unable to obtain sufficient surety bonding, letters of credit or third-party insurance coverage at reasonable cost, or one or more states cease to view captive insurance as adequate coverage, we would need to rely on other forms of financial assurance. It is possible that we could be forced to deposit cash to collateralize our obligations. Other forms of financial assurance could be more expensive to obtain, and any requirements to use cash to support our obligations would negatively impact our liquidity and capital resources and could affect our ability to meet our obligations as they become due.

We may record material charges against our earnings due to any number of events that could cause impairments to our assets.

In accordance with generally accepted accounting principles, we capitalize certain expenditures and advances relating to disposal site development, expansion projects, acquisitions, software development costs and other projects. Events that could, in some circumstances, lead to an impairment include, but are not limited to, shutting down a facility or operation or abandoning a development project or the denial of an expansion permit. If we determine a development or expansion project is impaired, we will charge against earnings any unamortized capitalized expenditures and advances relating to such facility or project reduced by any portion of the capitalized costs that we estimate will be recoverable, through sale or otherwise. We also carry a significant amount of goodwill on our Consolidated Balance Sheet, which is required to be assessed for impairment annually, and more frequently in the case of certain triggering events. We may be required to incur charges against earnings if we determine that events such as those described cause impairments. Any such charges could have a material adverse effect on our results of operations.

Our capital requirements and our business strategy could increase our expenses or cause us to change our growth and development plans, or fail to maintain our desired credit profile.

Recent economic conditions have reduced our cash flows from operations and could do so in the future. If impacts on our cash flows from operations are significant, we may reduce or suspend capital expenditures, growth and acquisition activity, implementation of our business strategy, dividend declarations or share repurchases. We may choose to incur indebtedness to pay for these activities, and there can be no assurances that we would be able to incur indebtedness on terms we deem acceptable or that we would maintain our targeted balance of debt to equity. We also may need to incur indebtedness to refinance scheduled debt maturities, and it is possible that the cost of financing could increase significantly, thereby increasing our expenses and decreasing our net income. Further, our ability to execute our financial strategy and our ability to incur indebtedness depends on our ability to maintain investment grade ratings on our senior debt. The credit rating process is

contingent upon our credit profile, as well as a number of other factors, many of which are beyond our control. If we were unable to maintain our investment grade credit ratings in the future, our interest expense would increase and our ability to obtain financing on favorable terms could be adversely affected.

Additionally, we have \$2.2 billion of debt as of December 31, 2011 that is exposed to changes in market interest rates within the next twelve months because of the combined impact of our tax-exempt bonds, our interest rate swap agreements and borrowings outstanding under our Canadian Credit Facility. Therefore, increases in interest rates can increase our interest expenses which also would lower our net income and decrease our cash flow.

We may use our five-year, \$2.0 billion revolving credit facility to meet our cash needs, to the extent available. As of December 31, 2011, we had \$150 million of borrowings and \$1,012 million of letters of credit issued and supported by the facility, leaving an unused and available credit capacity of \$838 million. In the event of a default under our credit facility, we could be required to immediately repay all outstanding borrowings and make cash deposits as collateral for all obligations the facility supports, which we may not be able to do. Additionally, any such default could cause a default under many of our other credit agreements and debt instruments. Without waivers from lenders party to those agreements, any such default would have a material adverse effect on our ability to continue to operate.

The adoption of climate change legislation or regulations restricting emissions of “greenhouse gases” could increase our costs to operate.

Efforts to curtail the emission of GHGs, to ameliorate the effect of climate change, continue to advance on the federal, regional, and state level. Our landfill operations emit methane, identified as a GHG. In the 111th Congress, the U.S. House of Representatives passed a bill that would regulate GHGs comprehensively. While the centerpiece of that bill would be a GHG emission allowance cap-and-trade system, neither landfills nor qualifying waste-to-energy plants would be compelled to hold allowances for their GHG emissions. Rather, they would be subject to certain further emission controls to be determined through administrative rule-making. Should comprehensive federal climate change legislation be enacted, we expect it to impose costs on our operations, the materiality of which we cannot predict.

Absent comprehensive federal legislation to control GHG emissions, the EPA is moving ahead administratively under its existing Clean Air Act authority. In 2010, the EPA published a Prevention of Significant Deterioration (“PSD”) and Title V Greenhouse Gas Tailoring Rule (“PSD tailoring rule”). The rule sets new thresholds for GHG emissions that define when Clean Air Act permits are required under the PSD and Title V programs. The EPA’s legal authority to “tailor” statutory thresholds in this rule has been challenged, and the EPA has delayed regulation of certain emissions pending further regulatory analysis. We cannot predict the final requirements of stationary source rules that might apply to landfills and waste-to-energy facilities as a result of this rulemaking and, accordingly, further developments in this area could have a material effect on our results of operations or cash flows.

The seasonal nature of our business and “one-time” special projects cause our results to fluctuate, and prior performance is not necessarily indicative of our future results.

Our operating revenues tend to be somewhat higher in summer months, primarily due to the higher volume of construction and demolition waste. The volumes of industrial and residential waste in certain regions where we operate also tend to increase during the summer months. Our second and third quarter revenues and results of operations typically reflect these seasonal trends. Additionally, certain destructive weather conditions that tend to occur during the second half of the year, such as the hurricanes that most often impact our Southern Group, can actually increase our revenues in the areas affected. While weather-related and other “one-time” occurrences can boost revenues through additional work, as a result of significant start-up costs and other factors, such revenue sometimes generates earnings at comparatively lower margins. During 2010, our financial results included revenue generated as a result of clean-up efforts in connection with the oil spill along the Gulf Coast and the substantial flooding in Tennessee; however, these special projects have a limited time span.

Certain weather conditions, including severe weather storms, may result in the temporary suspension of our operations, which can significantly affect the operating results of the affected regions. The operating results of our first quarter also often reflect higher repair and maintenance expenses because we rely on the slower winter months, when waste flows are generally lower, to perform scheduled maintenance at our waste-to-energy facilities.

For these and other reasons, operating results in any interim period are not necessarily indicative of operating results for an entire year, and operating results for any historical period are not necessarily indicative of operating results for a future period. Our stock price may be negatively impacted by interim variations in our results.

We could be subject to significant fines and penalties, and our reputation could be adversely affected, if our businesses, or third parties with whom we have a relationship, were to fail to comply with United States or foreign laws or regulations.

Some of our projects and new business may be conducted in countries where corruption has historically been prevalent. It is our policy to comply with all applicable anti-bribery laws, such as the U.S. Foreign Corrupt Practices Act, and with applicable local laws of the foreign countries in which we operate, and we monitor our local partners' compliance with such laws as well. Our reputation may be adversely affected if we were reported to be associated with corrupt practices or if we or our local partners failed to comply with such laws. Such damage to our reputation could adversely affect our ability to grow our business. Additionally, violations of such laws could subject us to significant fines and penalties.

Currently pending or future litigation or governmental proceedings could result in material adverse consequences, including judgments or settlements.

We are involved in civil litigation in the ordinary course of our business and from time-to-time are involved in governmental proceedings relating to the conduct of our business. The timing of the final resolutions to these types of matters is often uncertain. Additionally, the possible outcomes or resolutions to these matters could include adverse judgments or settlements, either of which could require substantial payments, adversely affecting our liquidity.

We may experience adverse impacts on our reported results of operations as a result of adopting new accounting standards or interpretations.

Our implementation of and compliance with changes in accounting rules, including new accounting rules and interpretations, could adversely affect our reported financial position or operating results or cause unanticipated fluctuations in our reported operating results in future periods.

Item 1B. Unresolved Staff Comments.

None.

Item 2. Properties.

Our principal executive offices are in Houston, Texas, where we lease approximately 480,000 square feet under leases expiring in 2020. Our Group offices are in Pennsylvania, Illinois, Georgia, Arizona and New Hampshire. We also have field-based administrative offices in Arizona, Illinois, Texas and Connecticut. We own or lease real property in most locations where we have operations. We have operations in each of the fifty states, other than Montana. We also have operations in the District of Columbia, Puerto Rico and throughout Canada.

Our principal property and equipment consists of land (primarily landfills and other disposal facilities, transfer stations and bases for collection operations), buildings, vehicles and equipment. We believe that our vehicles, equipment, and operating properties are adequately maintained and sufficient for our current operations. However, we expect to continue to make investments in additional equipment and property for expansion, for replacement of assets, and in connection with our strategic growth plans. For more information, see *Management's Discussion and Analysis of Financial Condition and Results of Operations* included within this report.

The following table summarizes our various operations at December 31 for the periods noted:

| | <u>2011</u> | <u>2010</u> |
|---|-------------|-------------|
| Landfills: | | |
| Owned | 211 | 210 |
| Operated through lease agreements | 25 | 26 |
| Operated through contractual agreements | <u>35</u> | <u>35</u> |
| | 271 | 271 |
| Transfer stations | 287 | 286 |
| Material recovery facilities | 107 | 98 |
| Secondary processing facilities | 13 | 12 |
| Waste-to-energy facilities | 17 | 17 |
| Independent power production plants | 5 | 5 |

The following table provides certain information by Group regarding the 236 landfills owned or operated through lease agreements and a count, by Group, of landfills operated through contractual agreements, transfer stations and material recovery facilities as of December 31, 2011:

| | <u>Landfills Owned or Operated Through Lease Agreements</u> | | | <u>Landfills Operating Through Contractual Agreements</u> | <u>Transfer Stations</u> | <u>Material Recovery Facilities</u> | |
|--------------------|---|-----------------------------|---------------------------------|---|------------------------------|---|---------------------------------|
| | <u>Landfills</u> | <u>Total Acreage(a)</u> | <u>Permitted Acreage(b)</u> | | | | <u>Expansion Acreage(c)</u> |
| Eastern | 37 | 28,509 | 6,047 | 345 | 9 | 57 | 27 |
| Midwest | 74 | 33,829 | 9,692 | 1,102 | 9 | 98 | 23 |
| Southern | 80 | 39,622 | 13,078 | 136 | 10 | 72 | 20 |
| Western | 41 | 41,870 | 8,531 | 725 | 7 | 57 | 37 |
| Wheelabrator | <u>4</u> | <u>781</u> | <u>341</u> | <u>—</u> | <u>—</u> | <u>3</u> | <u>—</u> |
| | <u>236</u> | <u>144,611</u> | <u>37,689</u> | <u>2,308</u> | <u>35</u> | <u>287</u> | <u>107</u> |

- (a) “Total acreage” includes permitted acreage, expansion acreage, other acreage available for future disposal that has not been permitted, buffer land and other land owned or leased by our landfill operations.
- (b) “Permitted acreage” consists of all acreage at the landfill encompassed by an active permit to dispose of waste.
- (c) “Expansion acreage” consists of unpermitted acreage where the related expansion efforts meet our criteria to be included as expansion airspace. A discussion of the related criteria is included within the *Management’s Discussion and Analysis of Financial Condition and Results of Operations — Critical Accounting Estimates and Assumptions* section included herein.

Item 3. Legal Proceedings.

Information regarding our legal proceedings can be found under the *Litigation* section of Note 11 in the Consolidated Financial Statements included in this report.

Item 4. Mine Safety Disclosures.

Information concerning mine safety and other regulatory matters required by Section 1503(a) of the Dodd-Frank Wall Street Reform and Consumer Protection Act and Item 104 of Regulation S-K is included in Exhibit 95 to this annual report.

PART II

Item 5. *Market for Registrant’s Common Equity, Related Stockholder Matters and Issuer Purchases of Equity Securities.*

Our common stock is traded on the New York Stock Exchange (“NYSE”) under the symbol “WM.” The following table sets forth the range of the high and low per-share sales prices for our common stock as reported on the NYSE:

| | <u>High</u> | <u>Low</u> |
|---|-------------|------------|
| 2010 | | |
| First Quarter | \$35.00 | \$31.29 |
| Second Quarter | 35.98 | 31.18 |
| Third Quarter | 36.24 | 31.22 |
| Fourth Quarter | 37.25 | 34.09 |
| 2011 | | |
| First Quarter | \$38.58 | \$35.86 |
| Second Quarter | 39.69 | 36.22 |
| Third Quarter | 38.06 | 27.76 |
| Fourth Quarter | 35.52 | 29.77 |
| 2012 | | |
| First Quarter (through February 10, 2012) | \$35.53 | \$32.11 |

On February 10, 2012, the closing sale price as reported on the NYSE was \$35.21 per share. The number of holders of record of our common stock on February 10, 2012 was 13,682.

The graph below shows the relative investment performance of Waste Management, Inc. common stock, the Dow Jones Waste & Disposal Services Index and the S&P 500 Index for the last five years, assuming reinvestment of dividends at date of payment into the common stock. The graph is presented pursuant to SEC rules and is not meant to be an indication of our future performance.

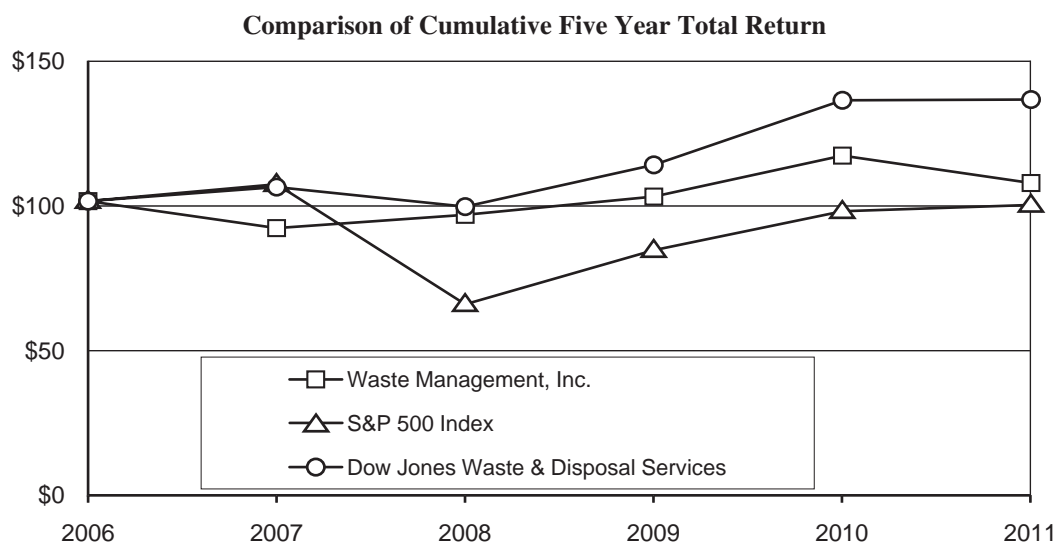

| | <u>12/31/06</u> | <u>12/31/07</u> | <u>12/31/08</u> | <u>12/31/09</u> | <u>12/31/10</u> | <u>12/31/11</u> |
|---|-----------------|-----------------|-----------------|-----------------|-----------------|-----------------|
| Waste Management, Inc. | \$100 | \$ 91.23 | \$95.55 | \$101.48 | \$114.80 | \$105.89 |
| S&P 500 Index | \$100 | \$105.49 | \$66.46 | \$ 84.05 | \$ 96.71 | \$ 98.76 |
| Dow Jones Waste & Disposal Services Index | \$100 | \$104.57 | \$98.21 | \$111.79 | \$132.79 | \$133.03 |

Our quarterly dividends have been declared by our Board of Directors and paid in accordance with our capital allocation programs. Cash dividends declared and paid were \$569 million in 2009, or \$1.16 per common share, \$604 million in 2010, or \$1.26 per common share and \$637 million in 2011, or \$1.36 per common share.

In 2011, we repurchased \$575 million of our common stock, pursuant to our capital allocation program. The following table summarizes common stock repurchases made during the fourth quarter of 2011:

| Issuer Purchases of Equity Securities | | | | |
|--|---|--|---|--|
| <u>Period</u> | <u>Total Number of Shares Purchased</u> | <u>Average Price Paid per Share(a)</u> | <u>Total Number of Shares Purchased as Part of Publicly Announced Plans or Programs</u> | <u>Approximate Maximum Dollar Value of Shares that May Yet be Purchased Under the Plans or Programs(b)</u> |
| October 1 — 31 | 913,700 | \$32.30 | 913,700 | \$— |
| November 1 — 30 | — | \$ — | — | \$— |
| December 1 — 31 | — | \$ — | — | \$— |
| Total | <u>913,700</u> | \$32.30 | <u>913,700</u> | \$— |

- (a) This amount represents the weighted average price paid per share and includes a per-share commission paid for all repurchases.
- (b) The approximate maximum dollar value of shares that may yet be purchased under the program is shown as zero because our capital allocation program, by its own terms, provided for up to \$575 million in share repurchases in 2011, and these repurchases were completed in October 2011.

In December 2011, we announced that our Board of Directors expects to increase the per share quarterly dividend from \$0.34 to \$0.355 for dividends declared in 2012. However, all future dividend declarations are at the discretion of the Board of Directors, and depend on various factors, including our net earnings, financial condition, cash required for future business plans and other factors the Board of Directions may deem relevant. Additionally, the Board of Directors approved up to \$500 million in share repurchases for 2012. However, future share repurchases will be made at the discretion of management, and will depend on factors similar to those considered by the Board of Directors in making dividend declarations.

Item 6. Selected Financial Data.

The information below was derived from the audited Consolidated Financial Statements included in this report and in previous annual reports we filed with the SEC. This information should be read together with those Consolidated Financial Statements and the notes thereto. The adoption of new accounting pronouncements, changes in certain accounting policies and certain reclassifications impact the comparability of the financial information presented below. These historical results are not necessarily indicative of the results to be expected in the future.

| | Years Ended December 31, | | | | |
|--|---|----------------|----------------|-----------------|-----------------|
| | 2011(a) | 2010(a) | 2009(a) | 2008 | 2007 |
| | (In millions, except per share amounts) | | | | |
| Statement of Operations Data: | | | | | |
| Operating revenues | \$13,378 | \$12,515 | \$11,791 | \$13,388 | \$13,310 |
| Costs and expenses: | | | | | |
| Operating | 8,541 | 7,824 | 7,241 | 8,466 | 8,402 |
| Selling, general and administrative | 1,551 | 1,461 | 1,364 | 1,477 | 1,432 |
| Depreciation and amortization | 1,229 | 1,194 | 1,166 | 1,238 | 1,259 |
| Restructuring | 19 | (2) | 50 | 2 | 10 |
| (Income) expense from divestitures, asset impairments and unusual items | 10 | (78) | 83 | (29) | (47) |
| | <u>11,350</u> | <u>10,399</u> | <u>9,904</u> | <u>11,154</u> | <u>11,056</u> |
| Income from operations | 2,028 | 2,116 | 1,887 | 2,234 | 2,254 |
| Other expense, net | (508) | (485) | (414) | (437) | (505) |
| Income before income taxes | 1,520 | 1,631 | 1,473 | 1,797 | 1,749 |
| Provision for income taxes | 511 | 629 | 413 | 669 | 540 |
| Consolidated net income | 1,009 | 1,002 | 1,060 | 1,128 | 1,209 |
| Less: Net income attributable to noncontrolling interests | 48 | 49 | 66 | 41 | 46 |
| Net income attributable to Waste Management, Inc. | <u>\$ 961</u> | <u>\$ 953</u> | <u>\$ 994</u> | <u>\$ 1,087</u> | <u>\$ 1,163</u> |
| Basic earnings per common share | <u>\$ 2.05</u> | <u>\$ 1.98</u> | <u>\$ 2.02</u> | <u>\$ 2.21</u> | <u>\$ 2.25</u> |
| Diluted earnings per common share | <u>\$ 2.04</u> | <u>\$ 1.98</u> | <u>\$ 2.01</u> | <u>\$ 2.19</u> | <u>\$ 2.23</u> |
| Cash dividends declared per common share | <u>\$ 1.36</u> | <u>\$ 1.26</u> | <u>\$ 1.16</u> | <u>\$ 1.08</u> | <u>\$ 0.96</u> |
| Balance Sheet Data (at end of period): | | | | | |
| Working capital (deficit) | \$ (689) | \$ (3) | \$ 109 | \$ (701) | \$ (118) |
| Goodwill and other intangible assets, net | 6,672 | 6,021 | 5,870 | 5,620 | 5,530 |
| Total assets | 22,569 | 21,476 | 21,154 | 20,227 | 20,175 |
| Debt, including current portion | 9,756 | 8,907 | 8,873 | 8,326 | 8,337 |
| Total Waste Management, Inc. stockholders' equity | 6,070 | 6,260 | 6,285 | 5,902 | 5,792 |
| Total equity | <u>6,390</u> | <u>6,591</u> | <u>6,591</u> | <u>6,185</u> | <u>6,102</u> |

(a) For more information regarding these financial data, see the *Management's Discussion and Analysis of Financial Condition and Results of Operations* section included in this report. For disclosures associated with the impact of the adoption of new accounting pronouncements and changes in our accounting policies on the comparability of this information, see Note 2 of the Consolidated Financial Statements.

Item 7. Management's Discussion and Analysis of Financial Condition and Results of Operations.

This section includes a discussion of our results of operations for the three years ended December 31, 2011. This discussion may contain forward-looking statements that anticipate results based on management's plans that are subject to uncertainty. We discuss in more detail various factors that could cause actual results to differ from expectations in Item 1A, *Risk Factors*. The following discussion should be read in light of that disclosure and together with the Consolidated Financial Statements and the notes to the Consolidated Financial Statements.

Overview

Our Company is dedicated to three transformational goals that we believe will drive continued growth and leadership in a dynamic industry: know more about our customers and how to service them than anyone else; use conversion and processing technology to extract more value from the materials we manage; and continuously improve our operational efficiency. Our strategy supports diversion from landfills and converting waste into valuable products as customers seek more economically and environmentally sound alternatives. We intend to pursue achievement of our long-term goals in the short-term through efforts to:

- Grow our markets by implementing customer-focused growth, through customer segmentation and through strategic acquisitions, while maintaining our pricing discipline and increasing the amount of recyclable materials we manage each year;
- Grow our customer loyalty;
- Grow into new markets by investing in greener technologies; and
- Pursue initiatives that improve our operations and cost structure.

These efforts will be supported by ongoing improvements in information technologies. We believe that execution of our strategy will provide long-term value to our stockholders.

Our 2011 results of operations reflect the impact of improved recyclable commodity prices and recycling volumes, our discipline in pricing and our continued investment in our strategic initiatives, including our July 28, 2011 acquisition of the primary operations of Oakleaf Global Holdings ("Oakleaf"). Highlights of our financial results for 2011 include:

- Revenues of \$13.4 billion compared with \$12.5 billion in 2010, an increase of \$863 million, or 6.9%. This increase in revenues is primarily attributable to:
 - Internal revenue growth from yield on our collection and disposal business of 1.8% in the current period, which increased revenue by \$193 million;
 - Increases from recyclable commodity prices of \$216 million; increases primarily from our fuel surcharge program of \$169 million; and increases from foreign currency translation of \$31 million; and
 - Increases associated with acquired businesses of \$449 million, of which \$251 million was related to Oakleaf;
- Internal revenue growth from volume was negative 1.5% in 2011, compared with negative 2.6% in 2010. The year-over-year decline in internal revenue growth due to volume was \$187 million, of which \$94 million relates to the oil spill clean-up project along the Gulf Coast in 2010. Revenue declines due to volume from our collection and waste-to-energy businesses were offset in part by revenue increases from our recycling brokerage business and our material recovery facilities;
- Operating expenses of \$8.5 billion, or 63.8% of revenues, compared with \$7.8 billion, or 62.5% of revenues, in 2010. This increase of \$717 million, or 9.2%, is due primarily to higher customer rebates related to increased recyclable commodity prices and volumes; the impact of higher fuel prices on direct fuel costs and indirect fuel costs included in subcontractor costs; and further increases in subcontractor costs associated in large part with our acquisition of Oakleaf, all of which have related revenue increases as noted above;

- Selling, general and administrative expenses increased \$90 million, or 6.2%, from \$1,461 million in 2010 to \$1,551 million in 2011, primarily due to costs incurred to support our strategic growth plans and initiatives, including our acquisition of Oakleaf, and cost savings programs. We began to see the associated benefits of our cost savings programs in the second half of the year and expect the benefits to increase throughout 2012;
- Income from operations of \$2.0 billion, or 15.2% of revenues, in 2011 compared with \$2.1 billion, or 16.9% of revenues, in 2010;
- Net income attributable to Waste Management, Inc. of \$961 million, or \$2.04 per diluted share for 2011, as compared with \$953 million, or \$1.98 per diluted share in 2010.
- Net cash provided by operating activities increased 8.5% from \$2.3 billion in 2010 to \$2.5 billion in 2011. We returned \$1.2 billion to our shareholders through dividends and share repurchases in 2011, compared with \$1.1 billion in 2010.

The following explanation of certain notable items that impacted the comparability of our 2011 results with 2010 has been provided to support investors' understanding of our performance. Our 2011 results were affected by the following:

- The recognition of a pre-tax charge of \$24 million as a result of a litigation loss, which had a negative impact of \$0.03 on our diluted earnings per share;
- The recognition of pre-tax restructuring charges, excluding charges recognized in the operating results of Oakleaf, of \$17 million related to our cost savings programs. These charges were primarily related to employee severance and benefit costs and had a negative impact of \$0.02 on our diluted earnings per share;
- The reduction in pre-tax earnings of approximately \$11 million related to the Oakleaf acquisition, which includes the operating results of Oakleaf and related interest expense and integration costs. These items had a negative impact of \$0.01 on our diluted earnings per share;
- The recognition of a favorable pre-tax benefit of \$9 million from a revision to an environmental remediation liability at a closed landfill, which had a positive impact of \$0.01 on our diluted earnings per share;
- The recognition of non-cash, pre-tax asset impairment charges of \$9 million primarily related to two of our medical waste services facilities. The impairment charges had a negative impact of \$0.01 on our diluted earnings per share; and
- The recognition of a tax benefit of \$19 million due to favorable tax audit settlements and favorable adjustments relating to the finalization of our 2010 tax returns. These items had a positive impact of \$0.04 on our diluted earnings per share.

Our 2010 results were affected by the following:

- The recognition of pre-tax charges aggregating \$55 million related to remediation and closure costs at five closed sites, which had a negative impact of \$0.07 on our diluted earnings per share;
- The recognition of net tax charges of \$32 million due to refinements in estimates of our deferred state income taxes and the finalization of our 2009 tax returns, partially offset by favorable tax audit settlements, all of which, combined, had a negative impact of \$0.07 on our diluted earnings per share;
- The recognition of a net favorable pre-tax benefit of \$46 million for litigation and associated costs, which had a favorable impact of \$0.06 on our diluted earnings per share; and
- The recognition of net pre-tax charges of \$26 million as a result of the withdrawal of certain of our union bargaining units from an underfunded multiemployer pension plan, which had a negative impact of \$0.03 on our diluted earnings per share.

We finished 2011 on a positive note with strong fourth quarter results that we intend to build upon going into 2012. Our employees are focused on continuing the progress that we have made on our strategic growth initiatives and cost savings programs. In 2012, we expect to continue to accomplish our goals of growing our revenue, expanding our operating margins, increasing our return on invested capital and returning cash to our shareholders.

Free Cash Flow — As is our practice, we are presenting free cash flow, which is a non-GAAP measure of liquidity, in our disclosures because we use this measure in the evaluation and management of our business. We define free cash flow as net cash provided by operating activities, less capital expenditures, plus proceeds from divestitures of businesses (net of cash divested) and other sales of assets. We believe it is indicative of our ability to pay our quarterly dividends, repurchase common stock, fund acquisitions and other investments and, in the absence of refinancings, to repay our debt obligations. Free cash flow is not intended to replace “Net cash provided by operating activities,” which is the most comparable U.S. GAAP measure. However, we believe free cash flow gives investors greater insight into how we view our liquidity. Nonetheless, the use of free cash flow as a liquidity measure has material limitations because it excludes certain expenditures that are required or that we have committed to, such as declared dividend payments and debt service requirements.

Our calculation of free cash flow and reconciliation to “Net cash provided by operating activities” is shown in the table below (in millions), and may not be the same as similarly-titled measures presented by other companies:

| | Years Ended December 31, | |
|---|-------------------------------------|-----------------|
| | 2011 | 2010 |
| Net cash provided by operating activities | \$ 2,469 | \$ 2,275 |
| Capital expenditures | (1,324) | (1,104) |
| Proceeds from divestitures of businesses (net of cash divested) and other sales of assets (a) | <u>53</u> | <u>44</u> |
| Free cash flow | <u>\$ 1,198</u> | <u>\$ 1,215</u> |

(a) Proceeds from divestitures of businesses for the year ended December 31, 2011 included the receipt of a payment of \$17 million related to a note receivable from a prior year divestiture. This repayment is included as a component of “Other” within “Cash flows from investing activities” in our Consolidated Statement of Cash Flows.

When comparing our cash flows from operating activities for the year ended December 31, 2011 to the comparable period in 2010, the change is primarily attributable to decreases in our income tax payments, which have positively affected our cash flow from operations this year, as well as a cash payment of \$37 million made when our Canadian hedges matured in December 2010. This current year increase was partially offset by a favorable cash benefit of \$77 million resulting from a litigation settlement in April 2010 and a \$65 million federal tax refund in the third quarter of 2010 related to the liquidation of a foreign subsidiary in 2009.

The increase in capital expenditures is a result of our increased spending on natural gas vehicles and fueling infrastructure, information technology infrastructure and growth initiatives, as well as our taking advantage of bonus depreciation. The year-over-year increase in capital expenditures was also affected by timing differences associated with cash payments for the previous years’ fourth quarter capital spending. We generally use a significant portion of our free cash flow on capital spending in the fourth quarter of each year. A more significant portion of our fourth quarter 2010 spending was paid in cash in 2011 than in the preceding year.

Our ability to generate \$1.2 billion in free cash flow in 2011 enabled us to return \$1.2 billion in cash to stockholders during the year through the payment of \$637 million in dividends and the repurchase of \$575 million of our common stock.

Acquisition of Oakleaf Global Holdings — On July 28, 2011, we paid \$432 million, net of cash received of \$4 million and inclusive of certain adjustments, to acquire Oakleaf. Oakleaf provides outsourced waste and recycling services through a nationwide network of third-party haulers. The operations we acquired generated approximately \$580 million in revenues in 2010. We acquired Oakleaf to advance our growth and transformation strategies and increase our national accounts customer base while enhancing our ability to provide comprehensive environmental solutions. For the year ended December 31, 2011, we incurred \$1 million of acquisition-related costs, which are classified as “Selling, general and administrative” expenses. Since the acquisition date, Oakleaf has recognized revenues of \$265 million and net income of less than \$1 million, which are included in our Consolidated Statement of Operations.

The following table shows adjustments to the preliminary allocation of the purchase price of Oakleaf to tangible and intangible assets acquired and liabilities assumed based on their estimated fair value from September 30, 2011 to December 31, 2011 (in millions):

| | <u>September 30, 2011</u> | <u>Adjustments (a)</u> | <u>December 31, 2011</u> |
|--|---------------------------|------------------------|--------------------------|
| Accounts and other receivables | \$ 68 | \$ 2 | \$ 70 |
| Other current assets | 28 | — | 28 |
| Property and equipment | 77 | (5) | 72 |
| Goodwill | 320 | 7 | 327 |
| Other intangible assets | 92 | (5) | 87 |
| Accounts payable | (80) | (2) | (82) |
| Accrued liabilities | (48) | — | (48) |
| Deferred income taxes, net | (13) | 3 | (10) |
| Other liabilities | <u>(12)</u> | <u>—</u> | <u>(12)</u> |
| Total purchase price | <u>\$432</u> | <u>\$—</u> | <u>\$432</u> |

(a) The purchase price adjustments relate primarily to changes in the valuation of the customer and vendor relationships and evaluation of physical and market conditions of equipment.

The following table presents the preliminary allocation of the purchase price to intangible assets (amounts in millions, except for amortization periods):

| | <u>Amount</u> | <u>Weighted Average Amortization Periods (in Years)</u> |
|---|---------------|---|
| Customer relationships | \$74 | 10.0 |
| Vendor relationships | 4 | 10.0 |
| Trademarks | <u>9</u> | 15.0 |
| Total intangible assets subject to amortization | <u>\$87</u> | 10.5 |

Goodwill of \$327 million was calculated as the excess of the consideration paid over the net assets recognized and represents the future economic benefits arising from other assets acquired that could not be individually identified and separately recognized. Goodwill is a result of expected synergies from combining the Company’s operations with Oakleaf’s national accounts customer base and vendor network. The vendor-hauler network expands our partnership with third-party service providers. In many cases we can provide vendor-haulers with opportunities to maintain and increase their business by utilizing our extensive post-collection network. We believe this will generate significant benefits for the Company and for the vendor-haulers. Goodwill acquired has been allocated to our four geographic Groups based on our preliminary valuations. Goodwill related to this acquisition is not deductible for income tax purposes.

The following pro forma consolidated results of operations have been prepared as if the acquisition of Oakleaf occurred at January 1, 2010 (in millions, except per share amounts):

| | <u>Years Ended December 31,</u> | |
|---|---------------------------------|-------------|
| | <u>2011</u> | <u>2010</u> |
| Operating revenues | \$13,693 | \$13,059 |
| Net income attributable to Waste Management, Inc. | 955 | 935 |
| Basic earnings per common share | 2.03 | 1.95 |
| Diluted earnings per common share | 2.03 | 1.94 |

Basis of Presentation of Consolidated Financial Information

Goodwill Impairment Testing — In September 2011, the Financial Accounting Standards Board (“FASB”) amended authoritative guidance associated with goodwill impairment testing. The amended guidance provides companies the option to first assess qualitative factors to determine whether the existence of events or circumstances leads to a determination that it is more likely than not that the fair value of a reporting unit is less than its carrying amount before performing the two-step impairment test. If, after assessing the totality of events or circumstances, an entity determines it is not more likely than not that the fair value of a reporting unit is less than its carrying amount, then performing the two-step impairment test is unnecessary. The amendments are effective for goodwill impairment tests performed for fiscal years beginning after December 15, 2011; however, early adoption was permitted. The Company’s early adoption of this guidance in 2011 did not have an impact on our consolidated financial statements. Additional information on impairment testing can be found in Note 3 to the Consolidated Financial Statements.

Multiple-Deliverable Revenue Arrangements — In October 2009, the FASB amended authoritative guidance associated with multiple-deliverable revenue arrangements. This amended guidance addresses the determination of when individual deliverables within an arrangement are required to be treated as separate units of accounting and modifies the manner in which consideration is allocated across the separately identifiable deliverables. The amendments to authoritative guidance associated with multiple-deliverable revenue arrangements became effective for the Company on January 1, 2011. The new accounting standard has been applied prospectively to arrangements entered into or materially modified after the date of adoption. The adoption of this guidance has not had a material impact on our consolidated financial statements.

Consolidation of Variable Interest Entities — In June 2009, the FASB issued revised authoritative guidance associated with the consolidation of variable interest entities. The new guidance primarily uses a qualitative approach for determining whether an enterprise is the primary beneficiary of a variable interest entity and, is therefore, required to consolidate the entity. This new guidance generally defines the primary beneficiary as the entity that has (i) the power to direct the activities of the variable interest entity that can most significantly impact the entity’s performance and (ii) the obligation to absorb losses and the right to receive benefits from the variable interest entity that could be significant from the perspective of the entity. The new guidance also requires that we continually reassess whether we are the primary beneficiary of a variable interest entity rather than conducting a reassessment only upon the occurrence of specific events.

As a result of our implementation of this guidance, effective January 1, 2010, we deconsolidated certain final capping, closure, post-closure and environmental remediation trusts because we share power over significant activities of these trusts with others. Our financial interests in these entities are discussed in Note 20. The deconsolidation of these trusts has not materially affected our financial position, results of operations or cash flows during the periods presented.

Critical Accounting Estimates and Assumptions

In preparing our financial statements, we make numerous estimates and assumptions that affect the accounting for and recognition and disclosure of assets, liabilities, equity, revenues and expenses. We must make these estimates and assumptions because certain information that we use is dependent on future events, cannot be calculated with a high degree of precision from data available or simply cannot be readily calculated based on generally accepted methods. In some cases, these estimates are particularly difficult to determine and we must exercise significant judgment. In preparing our financial statements, the most difficult, subjective and complex estimates and the assumptions that present the greatest amount of uncertainty relate to our accounting for

landfills, environmental remediation liabilities, asset impairments, deferred income taxes and reserves associated with our insured and self-insured claims. Each of these items is discussed in additional detail below. Actual results could differ materially from the estimates and assumptions that we use in the preparation of our financial statements.

Landfills

Accounting for landfills requires that significant estimates and assumptions be made regarding (i) the cost to construct and develop each landfill asset; (ii) the estimated fair value of final capping, closure and post-closure asset retirement obligations, which must consider both the expected cost and timing of these activities; (iii) the determination of each landfill's remaining permitted and expansion airspace; and (iv) the airspace associated with each final capping event.

Landfill Costs — We estimate the total cost to develop each of our landfill sites to its remaining permitted and expansion capacity. This estimate includes such costs as landfill liner material and installation, excavation for airspace, landfill leachate collection systems, landfill gas collection systems, environmental monitoring equipment for groundwater and landfill gas, directly related engineering, capitalized interest, on-site road construction and other capital infrastructure costs. Additionally, landfill development includes all land purchases for the landfill footprint and required landfill buffer property. The projection of these landfill costs is dependent, in part, on future events. The remaining amortizable basis of each landfill includes costs to develop a site to its remaining permitted and expansion capacity and includes amounts previously expended and capitalized, net of accumulated airspace amortization, and projections of future purchase and development costs.

Final Capping Costs — We estimate the cost for each final capping event based on the area to be finally capped and the capping materials and activities required. The estimates also consider when these costs would actually be paid and factor in inflation and discount rates. Our engineering personnel allocate final landfill capping costs to specific final capping events. The landfill capacity associated with each final capping event is then quantified and the final capping costs for each event are amortized over the related capacity associated with the event as waste is disposed of at the landfill. We review these costs annually, or more often if significant facts change. Changes in estimates, such as timing or cost of construction, for final capping events immediately impact the required liability and the corresponding asset. When the change in estimate relates to a fully consumed asset, the adjustment to the asset must be amortized immediately through expense. When the change in estimate relates to a final capping event that has not been fully consumed, the adjustment to the asset is recognized in income prospectively as a component of landfill airspace amortization.

Closure and Post-Closure Costs — We base our estimates for closure and post-closure costs on our interpretations of permit and regulatory requirements for closure and post-closure monitoring and maintenance. The estimates for landfill closure and post-closure costs also consider when the costs would actually be paid and factor in inflation and discount rates. The possibility of changing legal and regulatory requirements and the forward-looking nature of these types of costs make any estimation or assumption less certain. Changes in estimates for closure and post-closure events immediately impact the required liability and the corresponding asset. When the change in estimate relates to a fully consumed asset, the adjustment to the asset must be amortized immediately through expense. When the change in estimate relates to a landfill asset that has not been fully consumed, the adjustment to the asset is recognized in income prospectively as a component of landfill airspace amortization.

Remaining Permitted Airspace — Our engineers, in consultation with third-party engineering consultants and surveyors, are responsible for determining remaining permitted airspace at our landfills. The remaining permitted airspace is determined by an annual survey, which is used to compare the existing landfill topography to the expected final landfill topography.

Expansion Airspace — We include currently unpermitted expansion airspace in our estimate of remaining permitted and expansion airspace in certain circumstances. First, to include airspace associated with an expansion effort, we must generally expect the initial expansion permit application to be submitted within one year, and the final expansion permit to be received within five years. Second, we must believe the success of obtaining the expansion permit is likely, considering the following criteria:

- Personnel are actively working on the expansion of an existing landfill, including efforts to obtain land use and local, state or provincial approvals;

- It is likely that the approvals will be received within the normal application and processing time periods for approvals in the jurisdiction in which the landfill is located;
- We have a legal right to use or obtain land to be included in the expansion plan;
- There are no significant known technical, legal, community, business, or political restrictions or similar issues that could impair the success of such expansion;
- Financial analysis has been completed, and the results demonstrate that the expansion has a positive financial and operational impact; and
- Airspace and related costs, including additional closure and post-closure costs, have been estimated based on conceptual design.

For unpermitted airspace to be initially included in our estimate of remaining permitted and expansion airspace, the expansion effort must meet all of the criteria listed above. These criteria are evaluated by our field-based engineers, accountants, managers and others to identify potential obstacles to obtaining the permits. Once the unpermitted airspace is included, our policy provides that airspace may continue to be included in remaining permitted and expansion airspace even if certain of these criteria are no longer met as long as we continue to believe we will ultimately obtain the permit, based on the facts and circumstances of a specific landfill. In these circumstances, continued inclusion must be approved through a landfill-specific review process that includes approval of our principal financial officer and a review by the Audit Committee of our Board of Directors on a quarterly basis. Of the 33 landfill sites with expansions at December 31, 2011, 11 landfills required the principal financial officer to approve the inclusion of the unpermitted airspace. Seven of these landfills required approval by our principal financial officer because of community or political opposition that could impede the expansion process. The remaining four landfills required approval primarily due to local zoning restrictions or because the permit application processes do not meet the one- or five-year requirements.

When we include the expansion airspace in our calculations of remaining permitted and expansion airspace, we also include the projected costs for development, as well as the projected asset retirement cost related to final capping, and closure and post-closure of the expansion in the amortization basis of the landfill.

Once the remaining permitted and expansion airspace is determined in cubic yards, an airspace utilization factor, or AUF, is established to calculate the remaining permitted and expansion capacity in tons. The AUF is established using the measured density obtained from previous annual surveys and is then adjusted to account for settlement. The amount of settlement that is forecasted will take into account several site-specific factors including current and projected mix of waste type, initial and projected waste density, estimated number of years of life remaining, depth of underlying waste, anticipated access to moisture through precipitation or recirculation of landfill leachate, and operating practices. In addition, the initial selection of the AUF is subject to a subsequent multi-level review by our engineering group, and the AUF used is reviewed on a periodic basis and revised as necessary. Our historical experience generally indicates that the impact of settlement at a landfill is greater later in the life of the landfill when the waste placed at the landfill approaches its highest point under the permit requirements.

After determining the costs and remaining permitted and expansion capacity at each of our landfills, we determine the per ton rates that will be expensed as waste is received and deposited at the landfill by dividing the costs by the corresponding number of tons. We calculate per ton amortization rates for each landfill for assets associated with each final capping event, for assets related to closure and post-closure activities and for all other costs capitalized or to be capitalized in the future. These rates per ton are updated annually, or more often, as significant facts change.

It is possible that actual results, including the amount of costs incurred, the timing of final capping, closure and post-closure activities, our airspace utilization or the success of our expansion efforts, could ultimately turn out to be significantly different from our estimates and assumptions. To the extent that such estimates, or related assumptions, prove to be significantly different than actual results, lower profitability may be experienced due to higher amortization rates, or higher expenses; or higher profitability may result if the opposite occurs. Most

significantly, if it is determined that the expansion capacity should no longer be considered in calculating the recoverability of the landfill asset, we may be required to recognize an asset impairment or incur significantly higher amortization expense. If at any time management makes the decision to abandon the expansion effort, the capitalized costs related to the expansion effort are expensed immediately.

Environmental Remediation Liabilities

We are subject to an array of laws and regulations relating to the protection of the environment. Under current laws and regulations, we may have liabilities for environmental damage caused by our operations, or for damage caused by conditions that existed before we acquired a site. These liabilities include potentially responsible party (“PRP”) investigations, settlements, and certain legal and consultant fees, as well as costs directly associated with site investigation and clean up, such as materials, external contractor costs and incremental internal costs directly related to the remedy. We provide for expenses associated with environmental remediation obligations when such amounts are probable and can be reasonably estimated. We routinely review and evaluate sites that require remediation and determine our estimated cost for the likely remedy based on a number of estimates and assumptions.

Where it is probable that a liability has been incurred, we estimate costs required to remediate sites based on site-specific facts and circumstances. We routinely review and evaluate sites that require remediation, considering whether we were an owner, operator, transporter, or generator at the site, the amount and type of waste hauled to the site and the number of years we were associated with the site. Next, we review the same type of information with respect to other named and unnamed PRPs. Estimates of the cost for the likely remedy are then either developed using our internal resources or by third-party environmental engineers or other service providers. Internally developed estimates are based on:

- Management’s judgment and experience in remediating our own and unrelated parties’ sites;
- Information available from regulatory agencies as to costs of remediation;
- The number, financial resources and relative degree of responsibility of other PRPs who may be liable for remediation of a specific site; and
- The typical allocation of costs among PRPs unless the actual allocation has been determined.

Asset Impairments

Our long-lived assets, including landfills and landfill expansions, are carried on our financial statements based on their cost less accumulated depreciation or amortization. We monitor the carrying value of our long-lived assets for potential impairment whenever events or changes in circumstances, including management decisions pertaining to such assets, indicate that their carrying amounts may not be recoverable. These events or changes in circumstances are referred to as impairment indicators. If an impairment indicator occurs, we perform a test of recoverability by comparing the carrying value of the asset or asset group to its undiscounted expected future cash flows. If cash flows cannot be separately and independently identified for a single asset, we will determine whether an impairment has occurred for the group of assets for which we can identify the projected cash flows. If the carrying values are in excess of undiscounted expected future cash flows, we measure any impairment by comparing the fair value of the asset or asset group to its carrying value. Fair value is generally determined by considering (i) internally developed discounted projected cash flow analysis of the asset or asset group; (ii) actual third-party valuations; and/or (iii) information available regarding the current market for similar assets. If the fair value of an asset or asset group is determined to be less than the carrying amount of the asset or asset group, an impairment in the amount of the difference is recorded in the period that the impairment indicator occurs and is included in the “(Income) expense from divestitures, asset impairments and unusual items” line item in our Consolidated Statement of Operations. Estimating future cash flows requires significant judgment and projections may vary from the cash flows eventually realized, which could impact our ability to accurately assess whether an asset has been impaired.

There are other considerations for impairments of landfills, goodwill and other indefinite-lived intangible assets, as described below.

Landfills — The assessment of impairment indicators and the recoverability of our capitalized costs associated with landfills and related expansion projects require significant judgment due to the unique nature of the waste industry, the highly regulated permitting process and the sensitive estimates involved. During the review of a landfill expansion application, a regulator may initially deny the expansion application although the expansion permit is ultimately granted. In addition, management may periodically divert waste from one landfill to another to conserve remaining permitted landfill airspace, or a landfill may be required to cease accepting waste, prior to receipt of the expansion permit. However, such events occur in the ordinary course of business in the waste industry and do not necessarily result in impairment of our landfill assets because, after consideration of all facts, such events may not affect our belief that we will ultimately obtain the expansion permit. As a result, our tests of recoverability, which generally make use of a probability-weighted cash flow estimation approach, may indicate that no impairment loss should be recorded. At December 31, 2011, three of our landfill sites in two jurisdictions in the Company's Midwest Group, for which we believe receipt of expansion permits is probable, had ceased accepting waste. The net recorded capitalized landfill asset cost for these three sites was \$469 million at December 31, 2011. We performed tests of recoverability for these landfills and the undiscounted cash flows resulting from our probability-weighted estimation approach significantly exceeded the carrying values of each of these three sites.

Goodwill and Other Indefinite-Lived Intangible Assets — At least annually, and more frequently if warranted, we assess our goodwill and indefinite-lived intangible assets for impairment.

We assess whether a goodwill impairment exists using both qualitative and quantitative assessments. Our qualitative assessment involves determining whether events or circumstances exist that indicate it is more likely than not that the fair value of a reporting unit is less than its carrying amount, including goodwill. If based on this qualitative assessment we determine it is not more likely than not that the fair value of a reporting unit is less than its carrying amount, we will not perform a quantitative assessment.

If the qualitative assessment indicates that it is more likely than not that the fair value of a reporting unit is less than its carrying amount or if we elect not to perform a qualitative assessment, we perform a quantitative assessment or two-step impairment test to determine whether a goodwill impairment exists at the reporting unit. The first step in our quantitative assessment identifies potential impairments by comparing the estimated fair value of each reporting unit to its carrying value, including goodwill. If the carrying value exceeds estimated fair value, there is an indication of potential impairment and the second step is performed to measure the amount of impairment. Fair value is typically estimated using an income approach or a combination of the income approach and market approach when applicable. The income approach is based on the long-term projected future cash flows of our reporting units. We discount the estimated cash flows to present value using a weighted-average cost of capital that considers factors such as market assumptions, the timing of the cash flows and the risks inherent in those cash flows. We believe that this approach is appropriate because it provides a fair value estimate based upon our reporting units' expected long-term performance considering the economic and market conditions that generally affect our business. The market approach estimates fair value by measuring the aggregate market value of publicly-traded companies with similar characteristics to our business as a multiple of their reported cash flows. We then apply that multiple to our reporting units' cash flows to estimate their fair values. We believe that this approach is appropriate because it provides a fair value estimate using valuation inputs from entities with operations and economic characteristics comparable to our reporting units.

Fair value computed by these two methods is arrived at using a number of factors, including projected future operating results, economic projections, anticipated future cash flows, comparable marketplace data and the cost of capital. There are inherent uncertainties related to these factors and to our judgment in applying them to this analysis. However, we believe that these two methods provide a reasonable approach to estimating the fair value of our reporting units.

We assess whether other indefinite-lived intangible asset impairments exist by comparing the fair value of the asset with its carrying value. Fair value is typically estimated using an income approach for the respective asset, as described above. If the carrying value exceeds estimated fair value, an impairment would be recognized in the amount of the excess.

Refer to Note 6 to the Consolidating Financial Statements for additional information related to goodwill impairment considerations made during the reported periods.

Deferred Income Taxes

Deferred income taxes are based on the difference between the financial reporting and tax basis of assets and liabilities. The deferred income tax provision represents the change during the reporting period in the deferred tax assets and deferred tax liabilities, net of the effect of acquisitions and dispositions. Deferred tax assets include tax loss and credit carry-forwards and are reduced by a valuation allowance if, based on available evidence, it is more likely than not that some portion or all of the deferred tax assets will not be realized. Significant judgment is required in assessing the timing and amounts of deductible and taxable items. We establish reserves for uncertain tax positions when, despite our belief that our tax return positions are fully supportable, we believe that certain positions may be challenged and potentially disallowed. When facts and circumstances change, we adjust these reserves through our provision for income taxes.

Insured and Self-Insured Claims

We have retained a significant portion of the risks related to our health and welfare, automobile, general liability and workers' compensation insurance programs. Our liabilities associated with the exposure for unpaid claims and associated expenses, including incurred but not reported losses, are based on an actuarial valuation and internal estimates. The accruals for these liabilities could be revised if future occurrences or loss development significantly differ from our assumptions used. Estimated recoveries associated with our insured claims are recorded as assets when we believe that the receipt of such amounts is probable.

Results of Operations

Operating Revenues

We currently manage and evaluate our principal operations through five Groups. Our four geographic Groups, which are comprised of our Eastern, Midwest, Southern and Western Groups, provide collection, transfer, disposal (in both solid waste and hazardous waste landfills) and recycling services. Our fifth Group is the Wheelabrator Group, which provides waste-to-energy services and manages waste-to-energy facilities and independent power production plants. These five Groups are our reportable segments.

We also provide additional services that are not managed through our five Groups, including the Oakleaf operations we acquired on July 28, 2011, recycling brokerage services, electronic recycling services, in-plant services, landfill gas-to-energy services, integrated medical waste services and the impacts of investments that we are making in expanded service offerings and solutions. Part of our expansion of services includes offering portable self-storage services and fluorescent bulb and universal waste mail-back through our LampTracker® program. In addition, we have made investments that involve the acquisition and development of interests in oil and gas producing properties. These operations are presented as "Other" in the table below. Shown below (in millions) is the contribution to revenues during each year provided by our five Groups and our Other services:

| | Years Ended December 31, | | |
|--------------------|---------------------------------|-----------------|-----------------|
| | 2011 | 2010 | 2009 |
| Eastern | \$ 3,115 | \$ 2,943 | \$ 2,960 |
| Midwest | 3,213 | 3,048 | 2,855 |
| Southern | 3,390 | 3,461 | 3,328 |
| Western | 3,282 | 3,173 | 3,125 |
| Wheelabrator | 877 | 889 | 841 |
| Other | 1,532 | 963 | 628 |
| Intercompany | <u>(2,031)</u> | <u>(1,962)</u> | <u>(1,946)</u> |
| Total | <u>\$13,378</u> | <u>\$12,515</u> | <u>\$11,791</u> |

Our operating revenues generally come from fees charged for our collection, disposal, transfer, recycling and waste-to-energy services and from sales of commodities by our recycling, waste-to-energy and landfill gas-to-energy operations. Revenues from our collection operations are influenced by factors such as collection frequency, type of collection equipment furnished, type and volume or weight of the waste collected, distance to the disposal facility or MRF and our disposal costs. Revenues from our landfill operations consist of tipping fees, which are generally based on the type and weight or volume of waste being disposed of at our disposal facilities. Fees charged at transfer stations are generally based on the weight or volume of waste deposited, taking into account our cost of loading, transporting and disposing of the solid waste at a disposal site. Recycling revenue generally consists of tipping fees and the sale of recyclable commodities to third parties. The fees we charge for our collection, disposal, transfer and recycling services generally include fuel surcharges, which are indexed to current market costs for fuel. Our waste-to-energy revenues, which are generated by our Wheelabrator Group, are based on the type and weight or volume of waste received at our waste-to-energy facilities and IPPs and amounts charged for the sale of energy and steam. Our "Other" lines of business includes Oakleaf, our landfill gas-to-energy operations, Port-O-Let[®] services, portable self-storage, fluorescent lamp recycling and oil and gas producing properties. Intercompany revenues between our operations have been eliminated in the consolidated financial statements. The mix of operating revenues from our major lines of business is reflected in the table below (in millions):

| | Years Ended December 31, | | |
|--------------------|---------------------------------|-----------------|-----------------|
| | 2011 | 2010 | 2009 |
| Collection | \$ 8,406 | \$ 8,247 | \$ 7,980 |
| Landfill | 2,611 | 2,540 | 2,547 |
| Transfer | 1,280 | 1,318 | 1,383 |
| Wheelabrator | 877 | 889 | 841 |
| Recycling | 1,580 | 1,169 | 741 |
| Other | 655 | 314 | 245 |
| Intercompany | <u>(2,031)</u> | <u>(1,962)</u> | <u>(1,946)</u> |
| Total | <u>\$13,378</u> | <u>\$12,515</u> | <u>\$11,791</u> |

The following table provides details associated with the period-to-period change in revenues (dollars in millions) along with an explanation of the significant components of the current period changes:

| | Period-to-Period Change 2011 vs. 2010 | | Period-to-Period Change 2010 vs. 2009 | |
|------------------------------------|--|---|--|---|
| | Amount | As a % of Total Company(a) | Amount | As a % of Total Company(a) |
| Average yield(b) | \$ 572 | 4.6% | \$ 724 | 6.1% |
| Volume | <u>(187)</u> | <u>(1.5)</u> | <u>(304)</u> | <u>(2.6)</u> |
| Internal revenue growth | 385 | 3.1 | 420 | 3.5 |
| Acquisitions | 449 | 3.6 | 240 | 2.0 |
| Divestitures | (2) | — | (2) | — |
| Foreign currency translation | <u>31</u> | <u>0.2</u> | <u>66</u> | <u>0.6</u> |
| | <u>\$ 863</u> | <u>6.9%</u> | <u>\$ 724</u> | <u>6.1%</u> |

- (a) Calculated by dividing the amount of current year increase or decrease by the prior year's total company revenue adjusted to exclude the impacts of current year divestitures (\$12,513 million and \$11,789 million for 2011 and 2010, respectively).
- (b) The amounts reported herein represent the changes in our revenue attributable to average yield for the total Company. We also analyze the changes in average yield in terms of related-business revenues in order to

differentiate the changes in yield attributable to our pricing strategies from the changes that are caused by market-driven price changes in commodities. The following table summarizes changes in revenues from average yield on a related-business basis (dollars in millions):

| | Period-to-Period Change 2011 vs. 2010 | | Period-to-Period Change 2010 vs. 2009 | |
|---|---|--------------------------------------|---|--------------------------------------|
| | Amount | As a % of Related Business (i) | Amount | As a % of Related Business (i) |
| Average yield: | | | | |
| Collection, landfill and transfer | \$198 | 2.0% | \$218 | 2.2% |
| Waste-to-energy disposal(ii) | (5) | (1.1) | 21 | 5.1 |
| Collection and disposal(ii) | 193 | 1.8 | 239 | 2.3 |
| Recycling commodities | 216 | 17.8 | 423 | 58.5 |
| Electricity(ii) | (6) | (2.2) | (7) | (2.5) |
| Fuel surcharges and mandated fees | 169 | 37.7 | 69 | 18.4 |
| Total | <u>\$572</u> | 4.6 | <u>\$724</u> | 6.1 |

(i) Calculated by dividing the increase or decrease for the current year by the prior year's related business revenue, adjusted to exclude the impacts of divestitures for the current year. The table below summarizes the related business revenues for each year, adjusted to exclude the impacts of divestitures (in millions):

| | Denominator | |
|---|-----------------|-----------------|
| | 2011 | 2010 |
| Related-business revenues: | | |
| Collection, landfill and transfer | \$10,111 | \$ 9,999 |
| Waste-to-energy disposal | 466 | 413 |
| Collection and disposal | 10,577 | 10,412 |
| Recycling commodities | 1,215 | 723 |
| Electricity | 273 | 279 |
| Fuel surcharges and mandated fees | 448 | 375 |
| Total Company | <u>\$12,513</u> | <u>\$11,789</u> |

(ii) Average revenue growth for yield for "Collection and disposal" excludes all electricity-related revenues generated by our Wheelabrator Group and our landfill gas-to-energy operations, which are reported as "Electricity" revenues.

Our revenues increased \$863 million, or 6.9%, and \$724 million, or 6.1%, for the years ended December 31, 2011 and 2010, respectively. The year-over-year change in revenues for both periods has been driven by (i) market factors, including higher recyclable commodity prices; higher diesel fuel prices, which increase revenues provided by our fuel surcharge program; and foreign currency translation, which affects revenues from our Canadian operations; (ii) acquisitions, particularly the acquisition of Oakleaf, which increased consolidated revenues by \$251 million for 2011; and (iii) revenue growth from average yield on our collection and disposal operations. Offsetting these revenue increases were revenue declines due to lower volumes.

The following provides further details associated with our period-to-period change in revenues.

Average yield

Collection and disposal average yield — This measure reflects the effect on our revenue from the pricing activities of our collection, transfer, landfill and waste-to-energy disposal operations, exclusive of volume

changes. Revenue growth from collection and disposal average yield during both years includes not only base rate changes and environmental and service fee increases, but also (i) certain average price changes related to the overall mix of services, which are due to both the types of services provided and the geographic locations where our services are provided; (ii) changes in average price from new and lost business; and (iii) price decreases to retain customers.

In both 2011 and 2010, our revenue growth from collection and disposal average yield demonstrates our commitment to our pricing strategies. This increase in revenue from yield was primarily driven by our collection operations, which experienced yield growth in all lines of business and in every geographic Group. As discussed below, increased collection revenues due to average yield have been more than offset by revenue declines from lower collection volumes. However, revenue growth from yield on base business and our efforts toward controlling variable costs continue to favorably influence margin changes in our collection line of business.

In 2011, revenue growth from collection and disposal average yield was \$193 million, or 1.8%, as compared with the prior year. This revenue increase from yield was primarily driven by our collection operations; however, we also experienced yield growth from our disposal operations. Our 1.8% increase for 2011 is less than the 2.3% increase for 2010. This is due in large part to our residential line of business, in which we have experienced downward pressure on our revenue growth from yield across most of our geographic Groups, most notably in our Eastern and Southern Groups. Due to competition, it has become increasingly difficult to retain customers and to win new contracts at current average rates; as a result, in many instances, the Company has offered increased services, principally recycling services, when bidding on or renewing residential contracts and pursuing residential subscription business. Additional recycling services are typically at lower rates. This combination of increased competition and bundling of complementary services, such as recycling, in the residential line of business has put added pressure on our revenue growth from yield.

Our total collection and disposal revenue growth from yield has also been negatively affected during 2011, by factors including the changes in the mix of our temporary and permanent customers in our industrial business, particularly in North and South Florida. Additionally, we saw a \$5 million yield decline in our waste-to-energy facilities, primarily driven by the expiration of a long-term contract at one of our waste-to-energy operations in South Florida in August 2011. We expect this negative trend to continue into 2012 due to the expiration of a similar long-term contract that will occur at the end of March 2012. Although these factors discussed above negatively affected our revenue growth from yield in 2011 as compared with 2010, we did see a favorable rate of revenue growth from yield in our commercial line of business during 2011 as compared with the prior year. This favorable impact was driven by both price increases and additional service fees. Overall, we have found that increasing our revenue growth from yield in today's market is a challenge given the reduced volume levels resulting from the economic slowdown, the increased service offerings in many of our new contracts, and the highly competitive environment. Despite these headwinds, we continue to maintain our pricing discipline in order to improve yield on our base business.

Revenues from our environmental fee, which are included in average yield on collection and disposal, increased by \$37 million and \$33 million for the years ended December 31, 2011 and 2010, respectively. Environmental fee revenues totaled \$288 million in 2011 as compared with \$251 million in 2010 and \$218 million in 2009.

Recycling commodities — Increases in the prices of the recycling commodities we sold resulted in an increase in revenues of \$216 million in 2011 as compared with 2010. For the first nine months of 2011, our overall commodity prices increased approximately 26% as compared with the first nine months of the prior year. However, during the fourth quarter of 2011, we saw a decline of approximately 8% in commodity prices due to increased supply and lower demand.

In 2010, higher recycling commodity prices were the principal driver of our revenue increase of \$423 million as compared with 2009. Market prices for recyclable commodities increased significantly from the near-historic lows experienced in late 2008 and early 2009. For the twelve months of 2010, overall commodity prices increased approximately 57% as compared with 2009.

Fuel surcharges and mandated fees — These revenues, which are predominantly generated by our fuel surcharge program, increased by \$169 million and \$69 million for the years ended December 31, 2011 and 2010, respectively. This increase is directly attributable to higher national average prices for diesel fuel that we use for our fuel surcharge program. The mandated fees included in this line item are primarily related to the pass-through of fees and taxes assessed by various state, county and municipal governmental agencies at our landfills and transfer stations. These mandated fees have not had a significant impact on the comparability of revenues for the periods included in the table above.

Volume — Our revenue decline due to volume was \$187 million, or 1.5%, for the year ended December 31, 2011. This is a notable improvement in the rate of revenue decline from the prior year when revenue decline due to volume was \$304 million, or 2.6%. Volume declines are generally attributable to economic conditions, increased pricing, competition and increasing focus on waste reduction and diversion by consumers. Additionally, the oil spill clean-up activities along the Gulf Coast in 2010 unfavorably impacted our year-over-year volume change by \$94 million for the year ended December 31, 2011.

In 2011, volume declines from our collection business accounted for \$327 million of volume-related revenue decline. We experienced commercial and residential collection revenue declines due to lower volume that we attribute to the overall weakness in the economy, as well as the effects of pricing, competition and diversion of waste by consumers. Our industrial collection operations continued to be negatively affected by the current economic environment due to the construction slowdown across the United States. Lower third-party volumes in our transfer station operations also caused revenue declines in the current year and can generally be attributed to economic conditions and the effects of pricing and competition. Furthermore, as noted above, the overall year-over-year comparison of volumes in the collection line of business was unfavorably impacted by volume we received from the oil spill clean-up activities along the Gulf Coast in 2010. Additionally, in 2011, we experienced revenue declines at our waste-to-energy facilities, primarily driven by the expiration of a long-term electric power capacity agreement, which was offset to some extent by increases in waste tons processed and electricity produced.

Revenue declines due to volume detailed above were offset in part by revenue increases of \$101 million for the year ended December 31, 2011, primarily from year-over-year volume improvements in our recycling brokerage business and in our material recovery facilities. Our continued pursuit of municipal volumes as well as the addition of new single stream recycling facilities during 2011 contributed to these revenue increases due to volume. We also experienced volume-related revenue increases of \$37 million for the year ended December 31, 2011 from our strategic growth businesses and our landfill gas-to-energy operations. Additionally, our total landfill revenues increased \$41 million in 2011 due to higher third-party volumes as compared with the prior year, primarily driven by higher special waste volumes in our Eastern and Midwest geographic Groups. However, our landfill municipal solid waste volumes continued to decline in 2011 as compared with the prior year due to economic conditions, increased pricing, competition and increased focus on waste reduction and diversion by consumers.

In 2010, our collection business accounted for \$254 million of the total volume-related revenue decline. We experienced commercial and residential collection volume declines that we attributed to the overall weakness in the economy, as well as the effects of pricing, competition and diversion of waste by consumers. Our industrial collection operations were negatively affected by the economic environment due to the construction slowdown across the United States. The overall volume decline in the collection line of business was offset in part by an increase in volumes of \$99 million associated with oil spill clean-up activities along the Gulf Coast. Lower third-party volumes in our transfer station operations also caused revenue declines in 2010, and can generally be attributed to economic conditions and the effects of pricing and competition. However, in 2010, our landfill revenues increased due to higher third-party volumes. This increase was principally due to higher special waste volumes in our Midwest and Southern Groups, driven in part by our focus on our customers and better meeting their needs.

Acquisitions and divestitures — Revenues increased \$449 million and \$240 million for the years ended December 31, 2011 and 2010, respectively, due to acquisitions. The significant revenue increase due to acquisitions in 2011 was principally associated with Oakleaf, included in our “Other” business, demonstrating our current focus on identifying strategic growth opportunities in new, complementary lines of business. Additionally, revenue increased due to acquisitions in our collection, recycling and waste-to-energy lines of business in both periods. Divestitures accounted for decreased revenues of \$2 million in each of the years ended December 31, 2011 and 2010, respectively.

Operating Expenses

Our operating expenses include (i) labor and related benefits (excluding labor costs associated with maintenance and repairs discussed below), which include salaries and wages, bonuses, related payroll taxes, insurance and benefits costs and the costs associated with contract labor; (ii) transfer and disposal costs, which include tipping fees paid to third-party disposal facilities and transfer stations; (iii) maintenance and repairs relating to equipment, vehicles and facilities and related labor costs; (iv) subcontractor costs, which include the costs of independent haulers who transport waste collected by us to disposal facilities and are affected by variables such as volumes, distance and fuel prices; (v) costs of goods sold, which are primarily rebates paid to suppliers associated with recycling commodities; (vi) fuel costs, which represent the costs of fuel and oil to operate our truck fleet and landfill operating equipment; (vii) disposal and franchise fees and taxes, which include landfill taxes, municipal franchise fees, host community fees and royalties; (viii) landfill operating costs, which include interest accretion on landfill liabilities, interest accretion on and discount rate adjustments to environmental remediation liabilities and recovery assets, leachate and methane collection and treatment, landfill remediation costs and other landfill site costs; (ix) risk management costs, which include auto liability, workers' compensation, general liability and insurance and claim costs; and (x) other operating costs, which include, among other costs, equipment and facility rent, property taxes, utilities and supplies.

Our operating expenses increased \$717 million, or 9.2%, when comparing 2011 with 2010 and increased \$583 million, or 8.1%, when comparing 2010 with 2009. Operating expenses as a percentage of revenues were 63.8% in 2011, 62.5% in 2010 and 61.4% in 2009. The increases in our operating expenses during the years ended December 31, 2011 and 2010 can largely be attributed to the following:

Higher market prices for recyclable commodities — In both 2011 and 2010, increased market prices for recyclable commodities was the main driver of the increase in cost of goods sold, as presented in the table below, primarily due to customer recycling rebates, which also resulted in increased revenues and earnings. For the first nine months of 2011, our overall commodity prices increased approximately 26% as compared with the first nine months of the prior year. However, during the fourth quarter of 2011, we saw a decline of approximately 8% in commodity prices due to higher supply and lower demand. During 2010, market prices for recyclable commodities increased significantly from the near-historic lows experienced in late 2008 and early 2009, reflecting a 57% increase in 2010 as compared with 2009. Increases in cost of goods sold accounted for 41% and 49% of the year-over-year increases in total operating expenses during 2011 and 2010, respectively.

Fuel cost increases — Higher market prices for fuel caused increases in both our direct fuel costs and our subcontractor costs in both 2011 and 2010. On average, diesel fuel prices increased 29% in 2011 and 21% in 2010 as compared with the respective prior years. Diesel fuel prices averaged \$3.85, \$2.99 and \$2.46 per gallon for 2011, 2010 and 2009, respectively. We believe the total impact of fuel cost increases, when considering both the impact to our direct fuel costs and an estimate of the impact to our subcontractor costs, accounted for approximately 23% and 17% of the total year-over-year increase in operating expenses during 2011 and 2010, respectively. Increased revenues attributable to our fuel surcharge offset the unfavorable impact of higher fuel costs in 2011 and partially offset the unfavorable impact of higher fuel costs in 2010.

Acquisitions and growth initiatives — In both 2011 and 2010, we experienced cost increases attributable to recently acquired businesses and our various growth and business development initiatives. We estimate that these cost increases, which affected each of the operating cost categories identified in the table below, accounted for approximately 42% and 17% of our \$717 million and \$583 million increases in operating expenses during 2011 and 2010, respectively. Recent acquisitions included the purchase of Oakleaf and a number of collection and recycling operations. In particular, the acquisition of Oakleaf increased operating costs by \$213 million in the current year, primarily impacting subcontractor costs and, to a lesser extent, the cost of goods sold and other categories. The increase in operating expenses resulting from acquired businesses was more than offset by increased revenues from acquired businesses.

Canadian exchange rates — When comparing the average exchange rates for 2011 and 2010 to the prior year, the Canadian exchange rate strengthened by 4% and 10%, respectively, which increased our expenses in all operating cost categories. The strengthening of the Canadian dollar increased our total operating expenses by \$20 million for 2011 as compared with 2010 and \$52 million for 2010 as compared with 2009.

Volume declines — During 2011 and 2010, we continued to experience volume declines as a result of the ongoing weakness of the overall economic environment, pricing, competition and increased focus on waste reduction and diversion by consumers. We continue to manage our fixed costs and reduce our variable costs as we experience volume declines and have achieved cost savings as a result. These cost decreases have benefited each of the operating cost categories identified in the table below except for the cost of goods sold category, which increased as a result of additional customer rebates due to a 13% increase in recyclable material tons sold in 2011.

The following table summarizes the major components of our operating expenses, including the impact of foreign currency translation, for the years ended December 31 (dollars in millions):

| | <u>2011</u> | <u>Period-to- Period Change</u> | | <u>2010</u> | <u>Period-to- Period Change</u> | | <u>2009</u> |
|---|----------------|-------------------------------------|-------------|----------------|-------------------------------------|-------------|----------------|
| Labor and related benefits | \$2,336 | \$ 36 | 1.6% | \$2,300 | \$ 40 | 1.8% | \$2,260 |
| Transfer and disposal costs | 937 | (6) | (0.6) | 943 | 6 | 0.6 | 937 |
| Maintenance and repairs | 1,090 | 49 | 4.7 | 1,041 | 8 | 0.8 | 1,033 |
| Subcontractor costs | 948 | 178 | 23.1 | 770 | 70 | 10.0 | 700 |
| Cost of goods sold | 1,071 | 295 | 38.0 | 776 | 288 | 59.0 | 488 |
| Fuel | 628 | 135 | 27.4 | 493 | 79 | 19.1 | 414 |
| Disposal and franchise fees and taxes | 602 | 13 | 2.2 | 589 | 11 | 1.9 | 578 |
| Landfill operating costs | 255 | (39) | (13.3) | 294 | 72 | 32.4 | 222 |
| Risk management | 222 | 20 | 9.9 | 202 | (9) | (4.3) | 211 |
| Other | 452 | 36 | 8.7 | 416 | 18 | 4.5 | 398 |
| | <u>\$8,541</u> | <u>\$717</u> | <u>9.2%</u> | <u>\$7,824</u> | <u>\$583</u> | <u>8.1%</u> | <u>\$7,241</u> |

The significant period-to-period changes in our operating expenses by category are discussed below.

Labor and related benefits — The increases in 2011 and 2010 were primarily due to higher hourly and salaried wages due to merit increases and additional expenses incurred from acquisitions and growth opportunities, offset in part by cost savings that have been achieved as volumes have declined.

The comparability of our labor and related benefits costs for the periods presented has also been affected by costs incurred primarily associated with the withdrawal of certain bargaining units from underfunded multiemployer pension plans. These costs increased 2010 expense by \$26 million and 2009 expense by \$9 million.

Maintenance and repairs — Comparing 2011 with 2010, the increase was due to higher costs in our geographic Groups largely attributable to increased fleet maintenance costs, which include services provided by third-parties, tires, parts and internal shop labor costs. The increase in expense for tires and parts reflects the worldwide increase in commodity prices.

Subcontractor costs — The current year increase in subcontractor costs was primarily a result of the Oakleaf acquisition, increased diesel fuel prices, other recent acquisitions, our various growth and business development initiatives and additional costs associated with servicing our in-plant services customers. Oakleaf utilizes a nationwide network of third-party haulers to service its customers, which increased our subcontractor costs by \$153 million during the second half of 2011 after completing the acquisition on July 28, 2011. These increases were partially offset by the impact of an additional \$54 million in prior year costs attributable to oil spill clean-up activities along the Gulf Coast during 2010. The 2010 increase in subcontractor costs was largely the result of these oil spill clean-up activities, as well as higher diesel fuel prices when compared with 2009.

Cost of goods sold — The cost increases during 2011 and 2010 were primarily due to increases in the recycling commodity rebates we pay to our customers as a result of higher market prices for recyclable commodities. The increase in costs in 2011 was also driven by (i) increases in the volume of materials processed at our existing recycling facilities; and (ii) increases resulting from the Oakleaf acquisition and other recently acquired businesses.

Fuel — The costs increases for 2011 and 2010 were a result of higher market prices for diesel fuel.

Landfill operating costs — The changes in these costs during 2011 and 2010 were due largely to the recognition of additional estimated expense associated with environmental remediation liabilities of \$50 million at four closed sites during 2010. During 2011, the Company recognized a \$9 million favorable revision to an environmental liability at one of these sites based on the estimated cost of the remediation alternative selected by the EPA.

The changes in this category for the years presented were also significantly impacted by the changes in U.S. Treasury rates used to estimate the present value of our environmental remediation obligations and recovery assets. As a result of changes in U.S. Treasury rates, we recognized \$17 million of unfavorable adjustments during 2011, \$2 million of unfavorable adjustments during 2010, and \$35 million of favorable adjustments during 2009. During 2011, the discount rate we use decreased from 3.50% to 2.00%. Over the course of 2010, the discount rate decreased slightly from 3.75% to 3.50% and during 2009, the rate increased from 2.25% to 3.75%.

Risk management — The increase in risk management costs during 2011 was primarily a result of increased costs associated with auto and general liability claims in the current year and the prior year recognition of favorable adjustments associated with prior period claims that were higher than similar favorable adjustments recognized during 2011.

Other — The 2011 increase was attributable, in part, to our various growth and business development initiatives and recently acquired businesses, including Oakleaf. These increases were partially offset by prior year costs related to the oil spill clean-up activities along the Gulf Coast in 2010. The 2010 increase was attributable, in part, to our various growth and business development initiatives, oil spill clean-up activities along the Gulf Coast, and recently acquired businesses. These cost increases in 2010 were partially offset by an increase in gains recognized from the sale of surplus real estate assets.

Selling, General and Administrative

Our selling, general and administrative expenses consist of (i) labor and related benefit costs, which include salaries, bonuses, related insurance and benefits, contract labor, payroll taxes and equity-based compensation; (ii) professional fees, which include fees for consulting, legal, audit and tax services; (iii) provision for bad debts, which includes allowances for uncollectible customer accounts and collection fees; and (iv) other selling, general and administrative expenses, which include, among other costs, facility-related expenses, voice and data telecommunication, advertising, travel and entertainment, rentals, postage and printing. In addition, the financial impacts of litigation settlements generally are included in our “Other” selling, general and administrative expenses.

Our selling, general and administrative expenses increased by \$90 million, or 6.2%, and \$97 million, or 7.1% when comparing 2011 with 2010 and 2010 with 2009, respectively. The increases in both years are largely due to (i) increased costs of approximately \$53 million and \$52 million during 2011 and 2010, respectively, incurred to support our strategic plan to grow into new markets and provide expanded service offerings, including our acquisition of Oakleaf in 2011 and (ii) increased costs of \$9 million and \$23 million during 2011 and 2010, respectively, resulting from improvements we are making to our information technology systems. Additionally, during 2011 we experienced increased consulting costs of \$37 million incurred in connection with the start-up phase of new cost savings programs focusing on procurement and operational and back-office efficiency. Our selling, general and administrative expenses as a percentage of revenues were 11.6% in 2011, 11.7% in 2010 and 11.6% in 2009.

The following table summarizes the major components of our selling, general and administrative costs for the years ended December 31 (dollars in millions):

| | 2011 | Period-to-Period Change | | 2010 | Period-to-Period Change | | 2009 |
|----------------------------------|---------|-------------------------|------|---------|-------------------------|--------|---------|
| Labor and related benefits | \$ 913 | \$68 | 8.0% | \$ 845 | \$70 | 9.0% | \$ 775 |
| Professional fees | 185 | 10 | 5.7 | 175 | 8 | 4.8 | 167 |
| Provision for bad debts | 47 | 2 | 4.4 | 45 | (9) | (16.7) | 54 |
| Other | 406 | 10 | 2.5 | 396 | 28 | 7.6 | 368 |
| | \$1,551 | \$90 | 6.2% | \$1,461 | \$97 | 7.1% | \$1,364 |

Labor and related benefits — In 2011, our labor and related benefits costs increased primarily due to (i) higher compensation costs due to an increase in headcount driven by our strategic growth plans, optimization initiatives, cost savings programs, and acquisition of Oakleaf; (ii) higher salaries and hourly wages due to merit increases; and (iii) higher non-cash compensation costs incurred for our performance share units and our stock option equity awards granted under our long-term incentive plan, or LTIP, offset partially by lower costs associated with our executive salary deferral plan, the costs of which are directly affected by equity-market conditions. The stock option equity awards that the Company granted in 2011 and 2010 provide that such options will continue to vest on the schedule provided in the award agreement following an employee's retirement. Because retirement-eligible employees are not required to provide any future service to vest in these awards, we immediately recognized all of the compensation expense associated with stock option awards granted to retirement eligible employees. In 2011, the composition of our annual LTIP award grant was modified to use stock options to a greater extent and to reduce the number of performance share units awarded. Accordingly, costs increased in 2011 due to the significant increase in the number of stock option awards granted in 2011 over those granted in 2010 and an increase in the number of retirement-eligible employees receiving those awards.

In 2010, our labor and related benefits costs increased primarily due to (i) higher salaries and hourly wages due to merit increases; (ii) higher compensation costs due to an increase in headcount driven by our strategic growth plans; (iii) additional bonus expense in 2010 because our performance against targets established by our annual incentive plans was stronger in 2010 compared with 2009; (iv) increased contract labor costs as a result of our current focus on optimizing our information technology systems; (v) increased severance costs; and (vi) higher non-cash compensation costs incurred for equity awards granted under our LTIP. During the second quarter of 2009, we reversed all compensation costs previously recognized for our 2008 performance share units based on a determination that it was no longer probable that the targets established for that award would be met. Additionally, during the first quarter of 2010 we immediately recognized all of the compensation expense associated with stock option awards granted to retirement-eligible employees. We did not incur similar charges in 2009 because this retirement provision was not included in any of the equity awards that were granted during 2009.

Professional fees — During 2011, our professional fees increased due to consulting fees, primarily associated with the start-up phase of new cost savings programs, although these fees declined significantly during the second half of the year. We have begun to see the associated benefits of these programs and expect the benefits to increase throughout 2012. This increase was offset to a certain extent by lower legal fees in 2011 as compared with 2010. This reduction in legal fees in 2011 was primarily the result of the settlement in 2010 of a lawsuit related to the abandonment of revenue management software.

In 2010, our professional fees increased due to consulting fees, driven primarily by improvements we are made to our information technology systems and investments we made to support our strategic growth plans. This increase was partially offset by a reduction in legal fees in 2010 as compared with 2009.

Provision for bad debts — Our provision for bad debts was slightly higher in 2011 as compared with 2010, but both 2011 and 2010 were notably lower than 2009. Our provision was higher in 2009 as a result of the Company's assessment of the weak economic environment in the beginning of 2009 and the resulting impacts on our collection risk. However, due in part to management's continued focus on the collection of our receivables, our collection risk has moderated since 2009, thus resulting in a lower provision in both 2010 and 2011.

Other — During 2011 and 2010, we experienced increases in our computer costs, due in part to improvements we are making to our information technology systems, and litigation loss and settlement costs. Also driving the increase during 2010 was increased marketing and advertising costs, driven in part by our strategic growth plans.

Depreciation and Amortization

Depreciation and amortization includes (i) depreciation of property and equipment, including assets recorded for capital leases, on a straight-line basis from three to 50 years; (ii) amortization of landfill costs, including those incurred and all estimated future costs for landfill development, construction and asset retirement costs arising from closure and post-closure, on a units-of-consumption method as landfill airspace is consumed over the total estimated remaining capacity of a site, which includes both permitted capacity and expansion capacity that meets our Company-specific criteria for amortization purposes; (iii) amortization of landfill asset retirement costs arising from final capping obligations on a units-of-consumption method as airspace is consumed over the estimated capacity associated with each final capping event; and (iv) amortization of intangible assets with a definite life, either using a 150% declining balance approach or a straight-line basis over the definitive terms of the related agreements, which are generally from two to ten years depending on the type of asset.

The following table summarizes the components of our depreciation and amortization costs for the years ended December 31 (dollars in millions):

| | <u>2011</u> | <u>Period-to- Period Change</u> | | <u>2010</u> | <u>Period-to- Period Change</u> | | <u>2009</u> |
|---|----------------|---|-------------|----------------|---|-------------|----------------|
| Depreciation of tangible property and equipment | \$ 800 | \$19 | 2.4% | \$ 781 | \$ 2 | 0.3% | \$ 779 |
| Amortization of landfill airspace | 378 | 6 | 1.6 | 372 | 14 | 3.9 | 358 |
| Amortization of intangible assets | 51 | 10 | 24.4 | 41 | 12 | 41.4 | 29 |
| | <u>\$1,229</u> | <u>\$35</u> | <u>2.9%</u> | <u>\$1,194</u> | <u>\$28</u> | <u>2.4%</u> | <u>\$1,166</u> |

The increases in amortization expense of intangible assets in 2011 and 2010 are due to our focus on the growth and development of our business through acquisitions and other investments. The increase in amortization of intangible assets in 2011 is primarily related to the amortization of customer lists, which were acquired (i) through our acquisition of Oakleaf, (ii) by our Southern Group and (iii) by our recycling and electronic brokerage services business. The increase in amortization of intangible assets in 2010 is primarily related to the amortization of definite-lived operating permits acquired by our healthcare solutions operations, customer lists acquired by our Southern and Midwest Groups and gas rights acquired by our renewable energy operations.

Restructuring

Beginning in July 2011, we took steps to streamline our organization as part of our cost savings programs. This reorganization eliminated over 700 employee positions throughout the Company, including approximately 300 open positions. Additionally, subsequent to our acquisition of Oakleaf, we incurred charges in connection with restructuring that organization. During the year ended December 31, 2011, we recognized a total of \$19 million of pre-tax restructuring charges, of which \$18 million were related to employee severance and benefit costs associated with this reorganization.

In January 2009, we streamlined our organization by (i) consolidating our Market Areas from 45 Market Areas to 25 Market Areas; (ii) integrating the management of our recycling operations with our solid waste businesses in our four geographic Groups; and (iii) realigning our Corporate organization with this new structure in order to provide support functions more efficiently. This restructuring eliminated over 1,500 employee positions throughout the Company. During 2009, we recognized \$50 million of pre-tax charges associated with this restructuring, of which \$41 million were related to employee severance and benefit costs. The remaining charges were primarily related to lease obligations for property that will no longer be utilized. In 2010, we recognized \$2 million of income related to the reversal of pre-tax restructuring charges recorded in 2009.

(Income) Expense from Divestitures, Asset Impairments and Unusual Items

The following table summarizes the major components of “(Income) expense from divestitures, asset impairments and unusual items” for the year ended December 31 for the respective periods (in millions):

| | <u>Years Ended December 31,</u> | | |
|--|---------------------------------|---------------|-------------|
| | <u>2011</u> | <u>2010</u> | <u>2009</u> |
| (Income) expense from divestitures | \$ 1 | \$ (1) | \$— |
| Asset impairments | 9 | — | 83 |
| Other | — | (77) | — |
| | <u>\$10</u> | <u>\$(78)</u> | <u>\$83</u> |

Asset Impairments — During the year ended December 31, 2011, we recognized impairment charges relating primarily to two facilities in our medical waste services business as a result of the closure of one site and of continuing operating losses at the other site. We wrote down the net book values of the sites to their estimated fair values.

Through December 31, 2008, we capitalized \$70 million of accumulated costs associated with the development of a new waste and recycling revenue management system. A significant portion of these costs was specifically associated with the purchase of a license for waste and recycling revenue management software and the efforts required to develop and configure that software for our use. After a failed pilot implementation of the software in one of our smallest Market Areas, the development efforts associated with the revenue management system were suspended in 2007. During 2009, we determined to enhance and improve our existing revenue management system and not pursue alternatives associated with the development and implementation of the licensed software. Accordingly, in 2009, we recognized a non-cash charge of \$51 million for the abandonment of the licensed software.

We recognized an additional \$32 million of impairment charges during 2009, \$27 million of which was recognized by our Western Group during the fourth quarter of 2009 to fully impair a landfill in California as a result of a change in our expectations for the future operations of the landfill. The remaining impairment charges were primarily attributable to a charge required to write down certain of our investments in portable self-storage operations to their fair value as a result of our acquisition of a controlling financial interest in those operations.

Other — We filed a lawsuit in March 2008 related to the revenue management software implementation that was suspended in 2007 and abandoned in 2009. In April 2010, we settled the lawsuit and received a one-time cash payment. The settlement increased our “Income from operations” for the year ended December 31, 2010 by \$77 million.

Income from Operations by Reportable Segment

The following table summarizes income from operations by reportable segment for the years ended December 31 (dollars in millions):

| | <u>2011</u> | <u>Period-to-Period Change</u> | | <u>2010</u> | <u>Period-to-Period Change</u> | | <u>2009</u> |
|---------------------------|----------------|--------------------------------|---------------|----------------|--------------------------------|--------------|----------------|
| Reportable segments: | | | | | | | |
| Eastern | \$ 559 | \$ 43 | 8.3% | \$ 516 | \$ 33 | 6.8% | \$ 483 |
| Midwest | 646 | 113 | 21.2 | 533 | 83 | 18.4 | 450 |
| Southern | 779 | (65) | (7.7) | 844 | 76 | 9.9 | 768 |
| Western | 576 | 7 | 1.2 | 569 | 48 | 9.2 | 521 |
| Wheelabrator | 168 | (46) | (21.5) | 214 | (21) | (8.9) | 235 |
| Other | (116) | 19 | (14.1) | (135) | 1 | (0.7) | (136) |
| Corporate and other | (584) | (159) | 37.4 | (425) | 9 | (2.1) | (434) |
| Total | <u>\$2,028</u> | <u>\$ (88)</u> | <u>(4.2)%</u> | <u>\$2,116</u> | <u>\$229</u> | <u>12.1%</u> | <u>\$1,887</u> |

Reportable Segments — The most significant items affecting the results of operations of our four geographic Groups during the three-year period ended December 31, 2011 are summarized below:

- revenue growth from yield on our base business;
- market prices for recyclable commodities reflected significant year-over-year improvement in both 2011 and 2010;
- the accretive benefits of recent acquisitions during 2011 and 2010;
- continued volume declines in 2010, and to a lesser extent in 2011, due to the economy, pricing, competition and increasing focus on waste reduction and diversion by consumers;
- higher salaries and wages due to annual merit increases in both 2011 and 2010 for salaried and hourly employees. The increases during 2011 were offset, in large part, by the transfers of certain field sales organization employees to the Corporate sales organization;
- higher maintenance and repair costs during 2011; and
- restructuring charges during 2011 and 2009.

Other significant items affecting the comparability of our Groups' results of operations for the years ended December 31, 2011, 2010 and 2009 are summarized below:

Eastern — During 2009, the Group recognized (i) an \$18 million increase in revenues and income from operations associated with an oil and gas lease at one of our landfills; and (ii) a \$9 million charge related to bargaining unit employees in New Jersey agreeing to our proposal to withdraw them from an underfunded multiemployer pension fund.

Midwest — The income from operations of our Midwest Group in 2010 was significantly affected by the recognition of charges of \$26 million as a result of employees of five bargaining units in Michigan and Ohio agreeing to our proposal to withdraw them from an underfunded multiemployer pension plan.

Additionally, when comparing the average exchange rate in 2010 with 2009, the Canadian exchange rate strengthened by 10%, which increased the Group's income from operations. The effects of foreign currency translation were the most significant to this Group because substantially all of our Canadian operations are managed by our Midwest Group.

Southern — The decrease in income from operations of our Southern Group for the year ended December 31, 2011 as compared with 2010 was driven largely by the volume decline previously discussed, which includes the unfavorable year-over-year impact of 2010 project volumes resulting from oil spill clean-up activities along the Gulf Coast. Additionally, the Group recognized a charge of \$11 million in 2011 related to litigation reserves. This charge was initially recognized in "Other" during the fourth quarter of 2010.

Western — The Group's income from operations included additional "Selling, general and administrative" expense of \$24 million recognized in 2011 as a result of a litigation loss and \$12 million recognized in 2010 in connection with a litigation settlement. The Group's 2009 income from operations included the recognition of an impairment charge of \$27 million as a result of a change in expectations for the future operations of an inactive landfill in California.

Further affecting the comparison of results was the recognition of \$7 million of favorable adjustments to landfill amortization expense during 2010 associated with our obligations for landfill final capping, closure and post-closure and net expenses of \$5 million recognized for adjustments related to these obligations during 2009. The unfavorable adjustments during 2009 primarily related to a closed landfill in Los Angeles, California for which the Group recognized additional amortization expense.

Wheelabrator — The decrease in income from operations of our Wheelabrator Group for the year ended December 31, 2011 as compared with 2010 was driven largely by (i) lower revenues due to the expiration of a long-term electric power capacity agreement that expired December 31, 2010 and the expiration of other long-term contracts at our waste-to-energy and independent power facilities; (ii) an increase in year-to-date costs at our facility in Portsmouth, Virginia that we acquired in April 2010 as we

continue to refurbish the facility; and (iii) additional expenses recognized during 2011 for litigation reserves and associated compliance costs. A portion of the expenses for litigation reserves and associated costs were initially recognized in “Other” during the fourth quarter of 2010. The impact of these unfavorable items was partially offset by the efforts to control costs across each of our facilities.

The decrease in the Group’s 2010 income from operations as compared with 2009 was driven by an increase in maintenance-related outages as compared with the prior year, which resulted in decreased electricity generation and increased plant maintenance costs. These increases were attributable to the acceleration of repair and maintenance expenses at our facility in Portsmouth, Virginia that we acquired in April 2010, and expenses at certain of our other facilities. The Group also experienced an increase in litigation settlement costs as compared with 2009. These unfavorable items were partially offset by the benefit of increased revenues from the sale of metals.

Significant items affecting the comparability of the remaining components of our results of operations for the years ended December 31, 2011, 2010 and 2009 are summarized below:

Other — Our “Other” income from operations include (i) the effects of those elements of our in-plant services, landfill gas-to-energy operations, and third-party subcontract and administration revenues managed by our Sustainability Services, Renewable Energy and Strategic Accounts organizations, including Oakleaf, respectively, that are not included with the operations of our reportable segments; (ii) our recycling brokerage and electronic recycling services; and (iii) the impacts of investments that we are making in expanded service offerings, such as portable self-storage and fluorescent lamp recycling, and in oil and gas producing properties. In addition, our “Other” income from operations reflects the impacts of (i) non-operating entities that provide financial assurance and self-insurance support for the Groups or financing for our Canadian operations; and (ii) certain year-end adjustments recorded in consolidation related to the reportable segments that were not included in the measure of segment profit or loss used to assess their performance for the periods disclosed.

Significant items affecting the comparability of income from operations for the periods presented include (i) the reversal in 2011 of adjustments initially recorded in consolidation in the fourth quarter of 2010 related to our reportable segments, which are now included in the measure of segment income from operations in 2011 and (ii) losses from our growth initiatives. The adjustments recorded in consolidation were primarily related to \$15 million of additional expense for litigation reserves and associated costs in our Southern and Wheelabrator Groups. The losses from our growth initiatives are expected to drive year-over-year improvements in future periods.

Corporate and Other — Significant items affecting the comparability of expenses for the periods presented include:

- a benefit in 2010 of \$77 million resulting from a litigation settlement that occurred in April 2010 and \$51 million in charges recognized during 2009 for the abandonment of licensed software associated with the revenue management software implementation that was suspended in 2007 and abandoned in 2009;
- increases in “Selling, general and administrative” expenses for the periods presented as a result of cost increases attributable to (i) consulting fees primarily associated with our new cost savings programs focusing on procurement, operational efficiency and back office efficiency and (ii) additional compensation expense due to annual salary and wage increases, headcount increases to support the Company’s strategic growth plans, and an increase in costs attributable to our equity compensation. Also affecting the comparison during the periods presented is increased compensation expense during 2011 due to transfers of certain field sales organization employees to the Corporate sales organization and a favorable litigation settlement that occurred in 2010;
- the recognition of a \$9 million favorable adjustment during 2011 and net charges of \$50 million during 2010 for estimates associated with environmental remediation liabilities at certain of our closed sites;
- changes in U.S. Treasury rates used to estimate the present value of our environmental remediation obligations and recovery assets. As a result of changes in U.S. Treasury rates, we recognized \$17 million of unfavorable adjustments during 2011 and \$2 million of unfavorable adjustments during 2010, compared with \$35 million of favorable adjustments during 2009;

- an increase in 2011 risk management costs, primarily due to increased costs associated with auto and general liability claims and the recognition of a favorable adjustment in 2010 associated with prior period claims; and
- the recognition of \$9 million in restructuring charges during 2009.

Renewable Energy Operations

We have extracted value from the waste streams we manage for years, and we are focusing on increasing our ability to do so, particularly in the field of clean and renewable energy. Most significantly, our current operations produce renewable energy through the waste-to-energy facilities that are managed by our Wheelabrator Group and our landfill gas-to-energy operations. We are actively seeking opportunities to enhance our existing renewable energy service offerings to ensure that we can respond to the shifting demands of consumers and to ensure that we are acting as a leader in environmental stewardship.

We are disclosing the following supplemental information related to the operating results of our renewable energy operations for the years ended December 31, 2011 and 2010 (in millions) because we believe that it provides information related to the significance of our current renewable energy operations, the profitability of these operations and the costs we are incurring to develop these operations:

| | 2011 | | | | 2010 | | | |
|---|---------------|---------------------------|-------------------------|---------------|---------------|---------------------------|-------------------------|---------------|
| | Wheelabrator | Landfill Gas-to-Energy(a) | Growth Opportunities(b) | Total | Wheelabrator | Landfill Gas-to-Energy(a) | Growth Opportunities(b) | Total |
| Operating revenues (including intercompany) | \$ 877 | \$ 140 | \$ — | \$ 1,017 | \$ 889 | \$ 126 | \$ — | \$ 1,015 |
| Costs and expenses: | | | | | | | | |
| Operating | 548 | 60 | 2 | 610 | 512 | 51 | 2 | 565 |
| Selling, general & administrative | 92 | 3 | 3 | 98 | 99 | 3 | 3 | 105 |
| Depreciation and amortization | 67 | 28 | — | 95 | 64 | 24 | — | 88 |
| Restructuring and unusual items | 2 | — | — | 2 | — | — | — | — |
| | <u>709</u> | <u>91</u> | <u>5</u> | <u>805</u> | <u>675</u> | <u>78</u> | <u>5</u> | <u>758</u> |
| Income (loss) from operations | <u>\$ 168</u> | <u>\$ 49</u> | <u>\$ (5)</u> | <u>\$ 212</u> | <u>\$ 214</u> | <u>\$ 48</u> | <u>\$ (5)</u> | <u>\$ 257</u> |

- (a) Our landfill gas-to-energy business focuses on generating a renewable energy source from the methane that is produced as waste decomposes. The operating results include the revenues and expenses of landfill gas-to-energy plants that we own and operate, as well as revenues generated from the sale of landfill gas to third-party owner/operators. The operating results of our landfill gas-to-energy business are included within our geographic reportable segments and “Other”.
- (b) Includes businesses and entities we have acquired or invested in through our organic growth group’s business development efforts. These businesses include a landfill gas-to-LNG facility; landfill gas-to-diesel fuels technologies; organic waste streams-to-fuels technologies; and other engineered fuels technologies. The operating results of our Growth Opportunities are included within “Other” in our assessment of our income from operations by segment.

Interest Expense

Our interest expense was \$481 million in 2011, \$473 million in 2010 and \$426 million in 2009. When comparing 2011 with 2010, our interest expense increased only slightly in spite of a more significant increase in our debt balances over the course of the year of about \$850 million. This was primarily attributable to (i) a decrease in our weighted average borrowing rate that has been achieved by refinancing debt with scheduled maturities in 2011 with debt at much lower fixed interest rates; (ii) the impacts that lower market interest rates had on the cost of certain of our tax-exempt debt; and (iii) a \$5 million increase in capitalized interest due primarily to higher capital spending in 2011. In 2011, these decreases in interest expense were partially offset by a decrease in the benefits provided by active and terminated interest rate swap agreements due to the maturity of the underlying senior notes.

When comparing 2010 with 2009, the significant increase in our interest expense was primarily due to (i) the issuance of an additional \$600 million of senior notes in November 2009 to support acquisitions and investments made throughout 2010, (ii) significantly higher costs related to our revolving credit facility, and (iii) decreased benefits to interest expense provided by active interest rate swaps as a result of decreases in the notional amount of swaps outstanding. These increases in interest expense were offset, in part, by a decline in market interest rates, which reduced the interest costs of our tax-exempt borrowings and our Canadian credit facility.

Equity in Net Losses of Unconsolidated Entities

Beginning in April 2010, our “Equity in net losses of unconsolidated entities” has been primarily related to our noncontrolling interest in a limited liability company established to invest in and manage low-income housing properties, as well as (i) noncontrolling investments made to support our strategic initiatives and (ii) unconsolidated trusts for final capping, closure, post-closure or environmental obligations. In January 2011, we acquired a noncontrolling interest in a limited liability company established to invest in and manage a refined coal facility. The tax impacts realized as a result of our investments in low-income housing properties and the refined coal facility are discussed below in Provision for Income Taxes. Refer to Notes 9 and 20 to the Consolidated Financial Statements for more information related to these investments.

Provision for Income Taxes

We recorded provisions for income taxes of \$511 million in 2011, \$629 million in 2010 and \$413 million in 2009. These tax provisions resulted in an effective income tax rate of approximately 33.6%, 38.5% and 28.1%, for 2011, 2010 and 2009, respectively. The comparability of our reported income taxes for the years ended December 31, 2011, 2010 and 2009 is primarily affected by (i) variations in our income before income taxes; (ii) the utilization of a capital loss carry-back; (iii) the realization of state net operating loss and credit carry-forwards; (iv) changes in effective state and Canadian statutory tax rates; (v) tax audit settlements; and (vi) the impact of federal low-income housing and refined coal tax credits. The impacts of these items are summarized below:

- *Capital Loss Carry-back* — During 2009, we generated a capital loss from the liquidation of a foreign subsidiary. We determined that the capital loss could be utilized to offset capital gains from 2006 and 2007, which resulted in a reduction to our 2009 “Provision for income taxes” of \$65 million.
- *State Net Operating Loss and Credit Carry-forwards* — During 2011, 2010 and 2009, we utilized state net operating loss and credit carry-forwards resulting in a reduction to our “Provision for income taxes” for those periods of \$4 million, \$4 million, and \$35 million, respectively.
- *Canadian and State Tax Rate Changes* — During 2011, our state deferred income taxes increased by \$3 million to reflect the impact of changes in the estimated tax rate at which existing temporary differences will be realized. During 2010, our current state tax rate increased from 6.25% to 6.75% resulting in an increase to our provision for income taxes of \$5 million. In addition, our state deferred income taxes increased \$37 million to reflect the impact of changes in the estimated tax rate at which existing temporary differences will be realized. During 2009, our current state tax rate increased from 6.0% to 6.25% and our deferred state tax rate increased from 5.5% to 5.75%, resulting in an increase to our income taxes of \$3 million and \$6 million, respectively. Also affecting 2009 was the reduction of provincial tax rates in Ontario, which resulted in a \$13 million tax benefit as a result of the revaluation of the related deferred tax balances.
- *Tax Audit Settlements* — The settlement of various tax audits resulted in reductions in income tax expense of \$12 million for the year ended December 31, 2011, \$8 million for the year ended December 31, 2010 and \$11 million for the year ended December 31, 2009.
- *Federal Low-income Housing Tax Credits* — Our federal low-income housing investment and the resulting credits reduced our provision for income taxes by \$38 million for the year ended December 31, 2011 and \$26 million for the year ended December 31, 2010. Refer to Note 9 to the Consolidated Financial Statements for more information related to our federal low-income housing investment.

- *Refined Coal Investment Tax Credits* — Our refined coal facility investment and the resulting credits reduced our provision for income taxes by \$17 million for the year ended December 31, 2011. Refer to Note 9 to the Consolidated Financial Statements for more information related to our refined coal investment.

Our acquisition of Oakleaf did not materially impact our provision for income taxes or the effective income tax rate for the period ended December 31, 2011. We did receive, as part of the acquisition, income tax attributes (primarily federal and state net operating losses). While these tax attributes, when realized, will not affect our overall provision for income taxes, they will have a favorable impact on our cash taxes, although we do not anticipate the impact to be material to our overall cash flow from operations.

We expect our 2012 recurring effective tax rate will be approximately 35.5% based on expected income levels, projected federal tax credits and other permanent items.

The Tax Relief, Unemployment Insurance Reauthorization, and Job Creation Act, signed into law on December 17, 2010, included an extension of the bonus depreciation allowance through the end of 2012 and increased the amount of qualifying capital expenditures that can be depreciated immediately from 50% to 100%. The 100% depreciation deduction applies to qualifying property placed in service from September 8, 2010 through December 31, 2011. The acceleration of deductions on 2011 capital expenditures resulting from the bonus depreciation provision had no impact on our 2011 effective tax rate. However, the ability to accelerate depreciation deductions decreased our 2011 cash taxes by approximately \$190 million. Taking the accelerated tax depreciation will result in increased cash taxes in future periods when the deductions for these capital expenditures would have otherwise been taken.

Noncontrolling Interests

Net income attributable to noncontrolling interests was \$48 million in 2011, \$49 million in 2010 and \$66 million in 2009. These amounts are principally related to third parties' equity interests in two limited liability companies that own three waste-to-energy facilities operated by our Wheelabrator Group. The comparison of these amounts for the reported periods has been affected by (i) our January 2010 acquisition of a controlling financial interest in a portable self-storage business and (ii) the deconsolidation of certain final capping, closure, post-closure and environmental remediation trusts as a result of our implementation of authoritative accounting guidance, effective January 1, 2010, associated with variable interest entities. Refer to Note 20 to the Consolidated Financial Statements for information related to the consolidation of these variable interest entities.

Landfill and Environmental Remediation Discussion and Analysis

We owned or operated 266 solid waste and five secure hazardous waste landfills at December 31, 2011 and 2010. At December 31, 2011 and 2010, the expected remaining capacity, in cubic yards and tonnage of waste that can be accepted at our owned or operated landfills, is shown below (in millions):

| | <u>December 31, 2011</u> | | | <u>December 31, 2010</u> | | |
|---------------------------------|-------------------------------------|---------------------------|-----------------------|-------------------------------------|---------------------------|-----------------------|
| | <u>Remaining Permitted Capacity</u> | <u>Expansion Capacity</u> | <u>Total Capacity</u> | <u>Remaining Permitted Capacity</u> | <u>Expansion Capacity</u> | <u>Total Capacity</u> |
| Remaining cubic yards | 4,730 | 621 | 5,351 | 4,793 | 600 | 5,393 |
| Remaining tonnage | 4,485 | 621 | 5,106 | 4,391 | 603 | 4,994 |

Based on remaining permitted airspace as of December 31, 2011 and projected annual disposal volumes, the weighted average remaining landfill life for all of our owned or operated landfills is approximately 42 years. Many of our landfills have the potential for expanded disposal capacity beyond what is currently permitted. We monitor the availability of permitted disposal capacity at each of our landfills and evaluate whether to pursue an expansion at a given landfill based on estimated future waste volumes and prices, remaining capacity and likelihood of obtaining an expansion permit. We are seeking expansion permits at 33 of our landfills that meet the expansion criteria outlined in the *Critical Accounting Estimates and Assumptions* section above. Although no assurances can be made that all future expansions will be permitted or permitted as designed, the weighted average remaining landfill life for all owned or operated landfills is approximately 48 years when considering remaining permitted airspace, expansion airspace and projected annual disposal volume.

The number of landfills we own or operate as of December 31, 2011, segregated by their estimated operating lives (in years), based on remaining permitted and expansion airspace and projected annual disposal volume, was as follows:

| | <u>0 to 5</u> | <u>6 to 10</u> | <u>11 to 20</u> | <u>21 to 40</u> | <u>41+</u> | <u>Total</u> |
|---------------------------------|---------------|----------------|-----------------|-----------------|------------|--------------|
| Owned | 11 | 9 | 32 | 69 | 90 | 211 |
| Operated through lease(a) | 5 | 4 | 4 | 5 | 7 | 25 |
| Operating contracts(b) | <u>10</u> | <u>6</u> | <u>8</u> | <u>5</u> | <u>6</u> | <u>35</u> |
| Total landfills | <u>26</u> | <u>19</u> | <u>44</u> | <u>79</u> | <u>103</u> | <u>271</u> |

- (a) From an operating perspective, landfills we operate through lease agreements are similar to landfills we own because we own the landfill's operating permit and will operate the landfill for the entire lease term, which in many cases is the life of the landfill. We are usually responsible for the final capping, closure and post-closure obligations of the landfills we lease.
- (b) For operating contracts, the property owner owns the permit and we operate the landfill for a contracted term, which may be the life of the landfill. However, we are generally responsible for final capping, closure and post-closure obligations under the operating contracts.

The following table reflects landfill capacity and airspace changes, as measured in tons of waste, for landfills owned or operated by us during the years ended December 31, 2011 and 2010 (in millions):

| | <u>December 31, 2011</u> | | | <u>December 31, 2010</u> | | |
|--|-------------------------------------|---------------------------|-----------------------|-------------------------------------|---------------------------|-----------------------|
| | <u>Remaining Permitted Capacity</u> | <u>Expansion Capacity</u> | <u>Total Capacity</u> | <u>Remaining Permitted Capacity</u> | <u>Expansion Capacity</u> | <u>Total Capacity</u> |
| Balance, beginning of year . . . | 4,391 | 603 | 4,994 | 4,075 | 726 | 4,801 |
| Acquisitions, divestitures, newly permitted landfills and closures | — | — | — | 14 | — | 14 |
| Changes in expansions pursued(a) | — | 101 | 101 | — | 120 | 120 |
| Expansion permits granted(b) | 84 | (84) | — | 238 | (238) | — |
| Airspace consumed | (90) | — | (90) | (91) | — | (91) |
| Changes in engineering estimates and other(c) | <u>100</u> | <u>1</u> | <u>101</u> | <u>155</u> | <u>(5)</u> | <u>150</u> |
| Balance, end of year | <u>4,485</u> | <u>621</u> | <u>5,106</u> | <u>4,391</u> | <u>603</u> | <u>4,994</u> |

- (a) Amounts reflected here relate to the combined impacts of (i) new expansions pursued; (ii) increases or decreases in the airspace being pursued for ongoing expansion efforts; (iii) adjustments for differences between the airspace being pursued and airspace granted and (iv) decreases due to decisions to no longer pursue expansion permits.
- (b) We received expansion permits at eight of our landfills during 2011 and 13 of our landfills during 2010, demonstrating our continued success in working with municipalities and regulatory agencies to expand the disposal capacity of our existing landfills.
- (c) Changes in engineering estimates can result in changes to the estimated available remaining capacity of a landfill or changes in the utilization of such landfill capacity, affecting the number of tons that can be placed in the future. Estimates of the amount of waste that can be placed in the future are reviewed annually by our engineers and are based on a number of factors, including standard engineering techniques and site-specific factors such as current and projected mix of waste type; initial and projected waste density; estimated number of years of life remaining; depth of underlying waste; anticipated access to moisture through precipitation or recirculation of landfill leachate; and operating practices. We continually focus on

improving the utilization of airspace through efforts that include recirculating landfill leachate where allowed by permit; optimizing the placement of daily cover materials; and increasing initial compaction through improved landfill equipment, operations and training.

The tons received at our landfills in 2011 and 2010 are shown below (tons in thousands):

| | 2011 | | | 2010 | | |
|--|-------------------|-------------------|---------------------|-------------------|-------------------|---------------------|
| | <u># of Sites</u> | <u>Total Tons</u> | <u>Tons per Day</u> | <u># of Sites</u> | <u>Total Tons</u> | <u>Tons per Day</u> |
| Solid waste landfills | 266(a) | 91,130 | 334 | 266 | 91,863 | 336 |
| Hazardous waste landfills | <u>5</u> | <u>599</u> | <u>2</u> | <u>5</u> | <u>667</u> | <u>2</u> |
| | 271 | 91,729 | <u>336</u> | 271 | 92,530 | <u>338</u> |
| Solid waste landfills closed or divested during related year | 1 | <u>49</u> | | 3 | <u>295</u> | |
| | | <u>91,778(b)</u> | | | <u>92,825(b)</u> | |

(a) In 2011, we developed one landfill and closed one landfill.

(b) These amounts include 1.4 million tons at December 31, 2011 and 1.7 million tons at December 31, 2010 that were received at our landfills but were used for beneficial purposes and generally were redirected from the permitted airspace to other areas of the landfill. Waste types that are frequently identified for beneficial use include green waste for composting and clean dirt for on-site construction projects.

When a landfill we own or operate receives certification of closure from the applicable regulatory agency, we generally transfer the management of the site, including any remediation activities, to our closed sites management group. As of December 31, 2011, our closed sites management group managed 207 closed landfills.

Landfill Assets — We capitalize various costs that we incur to prepare a landfill to accept waste. These costs generally include expenditures for land (including the landfill footprint and required landfill buffer property), permitting, excavation, liner material and installation, landfill leachate collection systems, landfill gas collection systems, environmental monitoring equipment for groundwater and landfill gas, directly related engineering, capitalized interest, and on-site road construction and other capital infrastructure costs. The cost basis of our landfill assets also includes estimates of future costs associated with landfill final capping, closure and post-closure activities, which are discussed further below.

The following table reflects the total cost basis of our landfill assets and accumulated landfill airspace amortization as of December 31, 2011 and 2010, and summarizes significant changes in these amounts during 2011 (in millions):

| | <u>Cost Basis of Landfill Assets</u> | <u>Accumulated Landfill Airspace Amortization</u> | <u>Landfill Assets</u> |
|--|--------------------------------------|---|------------------------|
| December 31, 2010 | \$12,777 | \$(6,792) | \$5,985 |
| Capital additions | 398 | — | 398 |
| Asset retirement obligations incurred and capitalized .. | 49 | — | 49 |
| Acquisitions | — | — | — |
| Amortization of landfill airspace | — | (378) | (378) |
| Foreign currency translation | (32) | 8 | (24) |
| Asset retirements and other adjustments | <u>(252)</u> | <u>231</u> | <u>(21)</u> |
| December 31, 2011 | <u>\$12,940</u> | <u>\$(6,931)</u> | <u>\$6,009</u> |

As of December 31, 2011, we estimate that we will spend approximately \$400 million in 2012, and approximately \$1 billion in 2013 and 2014 combined for the construction and development of our landfill assets. The specific timing of landfill capital spending is dependent on future events, and spending estimates are subject to change due to fluctuations in landfill waste volumes, changes in environmental requirements and other factors impacting landfill operations.

Landfill and Environmental Remediation Liabilities — As we accept waste at our landfills, we incur significant asset retirement obligations, which include liabilities associated with landfill final capping, closure and post-closure activities. These liabilities are accounted for in accordance with authoritative guidance associated with accounting for asset retirement obligations, and are discussed in Note 3 of our Consolidated Financial Statements. We also have liabilities for the remediation of properties that have incurred environmental damage, which generally was caused by operations or for damage caused by conditions that existed before we acquired operations or a site. We recognize environmental remediation liabilities when we determine that the liability is probable and the estimated cost for the likely remedy can be reasonably estimated.

The following table reflects our landfill liabilities and our environmental remediation liabilities as of December 31, 2011 and 2010, and summarizes significant changes in these amounts during 2011 (in millions):

| | <u>Landfill</u> | <u>Environmental Remediation</u> |
|---|-----------------|--------------------------------------|
| December 31, 2010 | \$1,266 | \$284 |
| Obligations incurred and capitalized | 49 | — |
| Obligations settled | (80) | (37) |
| Interest accretion | 84 | 6 |
| Revisions in cost estimates and interest rate assumptions | (30) | 23 |
| Acquisitions, divestitures and other adjustments | 3 | (3) |
| December 31, 2011 | <u>\$1,292</u> | <u>\$273</u> |

Landfill Costs and Expenses — As disclosed in the *Operating Expenses* section above, our landfill operating costs include interest accretion on asset retirement obligations, interest accretion on and discount rate adjustments to environmental remediation liabilities and recovery assets, leachate and methane collection and treatment, landfill remediation costs, and other landfill site costs. The following table summarizes these costs for each of the three years indicated (in millions):

| | <u>Years Ended December 31,</u> | | |
|---|---------------------------------|--------------|--------------|
| | <u>2011</u> | <u>2010</u> | <u>2009</u> |
| Interest accretion on landfill liabilities | \$ 84 | \$ 82 | \$ 80 |
| Interest accretion on and discount rate adjustments to environmental remediation liabilities and recovery assets | 23 | 8 | (30) |
| Leachate and methane collection and treatment | 76 | 64 | 69 |
| Landfill remediation costs | — | 63 | 23 |
| Other landfill site costs | <u>72</u> | <u>77</u> | <u>80</u> |
| Total landfill operating costs | <u>\$255</u> | <u>\$294</u> | <u>\$222</u> |

The comparison of these costs for the reported periods has been significantly affected by accounting for changes in the risk-free discount rate that we use to estimate the present value of our environmental remediation liabilities and environmental remediation recovery assets, which is based on the rate for U.S. Treasury bonds with a term approximating the weighted-average period until settlement of the underlying obligations. Additionally, in 2010, we increased our cost estimates associated with environmental remediation obligations primarily based on a review and evaluation of existing remediation projects. As these remediation projects progressed, more defined plans were developed, resulting in a net increase in remediation expense to reflect the more likely remedies. In 2011, we had a favorable revision to an environmental remediation liability at a closed site based on the estimated cost of the remediation alternative selected by the EPA.

Amortization of landfill airspace, which is included as a component of “Depreciation and amortization” expense, includes the following:

- the amortization of landfill capital costs, including (i) costs that have been incurred and capitalized and (ii) estimated future costs for landfill development and construction required to develop our landfills to their remaining permitted and expansion airspace; and
- the amortization of asset retirement costs arising from final landfill capping, closure and post-closure obligations, including (i) costs that have been incurred and capitalized and (ii) projected asset retirement costs.

Amortization expense is recorded on a units-of-consumption basis, applying cost as a rate per ton. The rate per ton is calculated by dividing each component of the amortizable basis of a landfill by the number of tons needed to fill the corresponding asset’s airspace. Landfill capital costs and closure and post-closure asset retirement costs are generally incurred to support the operation of the landfill over its entire operating life, and are, therefore, amortized on a per-ton basis using a landfill’s total airspace capacity. Final capping asset retirement costs are related to a specific final capping event and are, therefore, amortized on a per-ton basis using each discrete final capping event’s estimated airspace capacity. Accordingly, each landfill has multiple per-ton amortization rates.

The following table presents our landfill airspace amortization expense on a per-ton basis:

| | <u>Years Ended December 31,</u> | | |
|--|---------------------------------|-------------|-------------|
| | <u>2011</u> | <u>2010</u> | <u>2009</u> |
| Amortization of landfill airspace (in millions) | \$ 378 | \$ 372 | \$ 358 |
| Tons received, net of redirected waste (in millions) | 90 | 91 | 92 |
| Average landfill airspace amortization expense per ton | \$4.19 | \$4.08 | \$3.90 |

Different per-ton amortization rates are applied at each of our 271 landfills, and per-ton amortization rates vary significantly from one landfill to another due to (i) inconsistencies that often exist in construction costs and provincial, state and local regulatory requirements for landfill development and landfill final capping, closure and post-closure activities; and (ii) differences in the cost basis of landfills that we develop versus those that we acquire. Accordingly, our landfill airspace amortization expense measured on a per-ton basis can fluctuate due to changes in the mix of volumes we receive across the Company year-over-year. The comparability of our total Company average landfill airspace amortization expense per ton for the years ended December 31, 2011, 2010 and 2009 has also been affected by the recognition of reductions to amortization expense for changes in our estimates related to our final capping, closure and post-closure obligations. Landfill amortization expense was reduced by \$11 million in 2011, \$13 million in 2010 and \$14 million in 2009, for the effects of these changes in estimates. In each year, the majority of the reduced expense resulted from revisions in the estimated timing or cost of final capping events that were generally the result of (i) concerted efforts to improve the operating efficiencies of our landfills and volume declines, both of which have allowed us to delay spending for final capping activities; (ii) effectively managing the cost of final capping material and construction; or (iii) landfill expansions that resulted in reduced or deferred final capping costs.

Liquidity and Capital Resources

We continually monitor our actual and forecasted cash flows, our liquidity and our capital resources, enabling us to plan for our present needs and fund unbudgeted business activities that may arise during the year as a result of changing business conditions or new opportunities. In addition to our working capital needs for the general and administrative costs of our ongoing operations, we have cash requirements for: (i) the construction and expansion of our landfills; (ii) additions to and maintenance of our trucking fleet and landfill equipment; (iii) construction, refurbishments and improvements at waste-to-energy and materials recovery facilities; (iv) the container and equipment needs of our operations; (v) final capping, closure and post-closure activities at our landfills; (vi) the repayment of debt and discharging of other obligations; and (vii) capital expenditures, acquisitions and investments in support of our strategic growth plans. We also are committed to providing our shareholders with a return on their investment through our capital allocation program that provides for dividend payments and share repurchases.

Summary of Cash and Cash Equivalents, Restricted Trust and Escrow Accounts and Debt Obligations

The following is a summary of our cash and cash equivalents, restricted trust and escrow accounts and debt balances as of December 31, 2011 and 2010 (in millions):

| | <u>2011</u> | <u>2010</u> |
|--|----------------|----------------|
| Cash and cash equivalents | \$ 258 | \$ 539 |
| Restricted trust and escrow accounts: | | |
| Final capping, closure, post-closure and environmental remediation funds | \$ 123 | \$ 124 |
| Tax-exempt bond funds | 14 | 14 |
| Other | <u>15</u> | <u>8</u> |
| Total restricted trust and escrow accounts | <u>\$ 152</u> | <u>\$ 146</u> |
| Debt: | | |
| Current portion | \$ 631 | \$ 233 |
| Long-term portion | <u>9,125</u> | <u>8,674</u> |
| Total debt | <u>\$9,756</u> | <u>\$8,907</u> |
| Increase in carrying value of debt due to hedge accounting for interest rate swaps | <u>\$ 102</u> | <u>\$ 79</u> |

Cash and cash equivalents — Cash and cash equivalents consist primarily of cash on deposit and money market funds that invest in U.S. government obligations with original maturities of three months or less. Our cash and cash equivalents have decreased as a result of the execution of our strategic growth plans, which has increased our level of capital spending, acquisitions and investments.

Restricted trust and escrow accounts — Restricted trust and escrow accounts consist primarily of (i) funds deposited for purposes of settling landfill final capping, closure, post-closure and environmental remediation obligations; and (ii) funds received from the issuance of tax-exempt bonds held in trust for the construction of various projects or facilities. These balances are primarily included within long-term “Other assets” in our Consolidated Balance Sheets.

Debt — We use long-term borrowings in addition to the cash we generate from operations as part of our overall financial strategy to support and grow our business. We primarily use senior notes and tax-exempt bonds to borrow on a long-term basis, but also use other instruments and facilities when appropriate. The components of our long-term borrowings as of December 31, 2011 are described in Note 7 to the Consolidated Financial Statements.

Changes in our outstanding debt balances from December 31, 2010 to December 31, 2011 were primarily due to (i) net debt borrowings of \$698 million; (ii) \$100 million in non-cash proceeds from tax-exempt borrowings; and (iii) the impacts of accounting for other non-cash changes in our debt balances due to hedge accounting for interest rate swaps, foreign currency translation, interest accretion and capital leases.

As of December 31, 2011, we had (i) \$925 million of debt maturing within twelve months, including \$150 million of borrowings outstanding under our revolving credit facility, U.S.\$137 million of advances outstanding under our Canadian credit facility, \$400 million of 6.375% senior notes that mature in November 2012 and \$168 million of tax-exempt bonds and (ii) \$305 million of fixed-rate tax-exempt borrowings subject to re-pricing within the next twelve months. Under accounting principles generally accepted in the United States, this debt must be classified as current unless we have the intent and ability to refinance it on a long-term basis. We have the intent and ability to refinance \$599 million of this debt on a long-term basis and have classified the remaining \$631 million as current obligations as of December 31, 2011. In January 2012, we borrowed an additional \$50 million under our revolving credit facility, increasing the total loans outstanding under our revolving credit facility to \$200 million.

We have credit facilities in place to support our liquidity and financial assurance needs. The following table summarizes our outstanding letters of credit (in millions) at December 31, categorized by type of facility:

| | <u>2011</u> | <u>2010</u> |
|--------------------------------------|----------------|----------------|
| Revolving credit facility(a) | \$1,012 | \$1,138 |
| Letter of credit facilities(b) | 502 | 505 |
| Other(c) | <u>251</u> | <u>237</u> |
| | <u>\$1,765</u> | <u>\$1,880</u> |

- (a) In May 2011, we amended and restated our \$2.0 billion revolving credit facility as a result of changes in market conditions, which significantly reduced the cost of the facility. We also extended the term through May 2016. At December 31, 2011, we had \$150 million of outstanding borrowings and \$1,012 million of letters of credit issued and supported by the facility, leaving an unused and available credit capacity of \$838 million.
- (b) As of December 31, 2011, we had an aggregate committed capacity of \$505 million under letter of credit facilities with terms that extend from June 2013 to June 2015. As of December 31, 2011, no borrowings were outstanding under these letter of credit facilities and we had \$3 million of unused or available credit capacity.
- (c) These letters of credit are outstanding under various arrangements that do not obligate the counterparty to provide a committed capacity.

Summary of Cash Flow Activity

The following is a summary of our cash flows for the years ended December 31 (in millions):

| | <u>2011</u> | <u>2010</u> | <u>2009</u> |
|---|------------------|------------------|------------------|
| Net cash provided by operating activities | <u>\$ 2,469</u> | <u>\$ 2,275</u> | <u>\$ 2,362</u> |
| Net cash used in investing activities | <u>\$(2,185)</u> | <u>\$(1,606)</u> | <u>\$(1,250)</u> |
| Net cash used in financing activities | <u>\$ (566)</u> | <u>\$(1,273)</u> | <u>\$ (457)</u> |

Net Cash Provided by Operating Activities — The most significant items affecting the comparison of our operating cash flows in 2011 as compared with 2010 are summarized below:

- *Decreased income tax payments* — Cash paid for income taxes, net of excess tax benefits, was approximately \$242 million lower in 2011 due in large part to the extension of the bonus depreciation legislation. The ability to accelerate depreciation deductions decreased our full year 2011 cash taxes by approximately \$175 million. Also contributing to the decrease in cash paid for taxes in 2011, is an increase in federal tax credits provided by our investments in two unconsolidated entities. These investments are discussed in Note 9 and Note 20 of the Consolidated Financial Statements.
- *2010 Non-recurring cash inflows* — Two significant cash transactions benefited cash provided by operating activities for the year ended December 31, 2010. In the second quarter of 2010, we received \$77 million for a litigation settlement, and in the third quarter of 2010, we received a \$65 million federal tax refund related to the liquidation of a foreign subsidiary in 2009.
- *Settlement of Canadian hedge* — In December 2010, our previously existing foreign currency hedges matured and we paid cash of \$37 million upon settlement. The cash payment from the settlement was classified as a change in accrued liabilities within “Net cash provided by operating activities” in the Consolidated Statement of Cash Flows.
- *Changes in assets and liabilities, net of effects from business acquisitions and divestitures* — Our cash flow from operations was favorably impacted in 2011 by changes in our working capital accounts. Although our working capital changes may vary from year to year, they are typically driven by changes in

accounts receivable, which are affected by both revenue changes and timing of payments received, and accounts payable changes, which are affected by both cost changes and timing of payments.

The most significant items affecting the comparison of our operating cash flows for 2010 and 2009 are summarized below:

- *Increase in earnings* — Our income from operations increased by \$229 million on a year-over-year basis, driven, in part, by a favorable cash benefit of \$77 million resulting from a litigation settlement in April 2010. This earnings increase was also impacted by (i) the recognition of a \$51 million non-cash charge associated with the abandonment of licensed revenue management software and (ii) the recognition of a \$27 million non-cash charge in 2009 as a result of a change in expectations for the future operations of an inactive landfill in California.

The comparison of our 2010 and 2009 income from operations was also affected by a \$91 million increase in non-cash charges attributable to (i) equity-based compensation expense; (ii) interest accretion on landfill liabilities; (iii) interest accretion and discount rate adjustments on environmental remediation liabilities and recovery assets; (iv) depreciation and amortization; and (v) the impact of the withdrawal of certain bargaining units from multiemployer pension plans. While these increases in non-cash charges unfavorably affected our earnings comparison, there was no impact on net cash provided by operating activities.

- *Changes in assets and liabilities, net of effects from business acquisitions and divestitures* — Our cash flow from operations was negatively impacted in 2010 and favorably impacted in 2009, by changes in our working capital accounts. Although our working capital changes may vary from year to year, they are typically driven by changes in accounts receivable, which are affected by both revenue changes and timing of payments received, and accounts payable changes, which are affected by both cost changes and timing of payments. Additionally, the following are other significant items that affected our cash flow from operations:

- *Increased income tax payments* — Cash paid for income taxes, net of excess tax benefits associated with equity-based transactions, was approximately \$86 million higher on a year-over-year basis. The comparability of our effective tax rates is discussed in the *Provision for income taxes* section above.
- *Increased interest payments* — Cash paid for interest was approximately \$61 million higher on a year-over-year basis. This increase was primarily due to (i) the issuance of an additional \$600 million of senior notes in November 2009 to support acquisitions and investments made throughout 2010; (ii) significantly higher costs related to the execution and maintenance of our revolving credit facility, which was refinanced in June 2010; and (iii) a decrease in benefits to interest expense provided by active interest rate swaps as a result of decreases in the notional amount of swaps outstanding.
- *Settlement of Canadian hedge* — In December 2010, our previously existing foreign currency hedges matured and we paid cash of \$37 million upon settlement. The cash payment from the settlement was classified as a change in accrued liabilities within “Net cash provided by operating activities” in the Consolidated Statement of Cash Flows.
- *Liquidation of a foreign subsidiary* — We received a \$65 million federal tax refund in the third quarter of 2010 related to the liquidation of a foreign subsidiary in 2009. The cash proceeds were classified as a change in other current assets within “Net cash provided by operating activities” in the Consolidated Statement of Cash Flows.

Net Cash Used in Investing Activities — The most significant items affecting the comparison of our investing cash flows for the periods presented are summarized below:

- *Capital expenditures* — We used \$1,324 million during 2011 for capital expenditures, compared with \$1,104 million in 2010 and \$1,179 million in 2009. The increase in capital expenditures in 2011 is a result of our increased spending on natural gas vehicles and fueling infrastructure, information technology infrastructure and growth initiatives, as well as our taking advantage of the bonus depreciation legislation. The year-over-year comparison of 2011 with 2010 was also affected by timing differences associated

with cash payments for the previous years' fourth quarter capital spending. Approximately \$206 million of our fourth quarter 2010 spending was paid in cash in the first quarter of 2011 compared with approximately \$145 million of our fourth quarter 2009 spending that was paid in the first quarter of 2010.

- *Acquisitions* — Our spending on acquisitions increased from \$281 million during 2009 to \$407 million in 2010 and to \$867 million in 2011. During the third quarter of 2011, we paid \$432 million, net of cash received of \$4 million and inclusive of certain adjustments, to acquire Oakleaf, which provides outsourced waste and recycling services through a nationwide network of third-party haulers. During the second quarter of 2010, we paid approximately \$150 million to acquire a waste-to-energy facility in Portsmouth, Virginia. We continue to focus on accretive acquisitions and growth opportunities that will contribute to improved future results of operations and enhance and expand our existing service offerings.
- *Investments in unconsolidated entities* — We made \$155 million of cash investments in unconsolidated entities during 2011. These investments included a \$48 million payment made to acquire a noncontrolling interest in a limited liability company, which was established to invest in and manage a refined coal facility in North Dakota, and \$107 million of investments primarily related to furthering our goal of growing into new markets by investing in greener technologies.

We made \$173 million of cash investments in unconsolidated entities during 2010. These cash investments were primarily related to a \$142 million payment made to acquire a 40% equity investment in Shanghai Environment Group, a subsidiary of Shanghai Chengtou Holding Co., Ltd. As a joint venture partner in SEG, we participate in the operation and management of waste-to-energy and other waste services in the Chinese market. SEG's focus also includes building new waste-to-energy facilities in China.

- *Net receipts from restricted funds* — Net cash received from our restricted trust and escrow accounts, which are largely generated from the issuance of tax-exempt bonds for our capital needs, contributed \$107 million to our investing activities in 2011 compared with \$48 million in 2010 and \$196 million in 2009. The significant decrease in cash received from our restricted trust and escrow accounts during 2010 was due to a decrease in tax-exempt borrowings.

Net Cash Used in Financing Activities — The most significant items affecting the comparison of our financing cash flows for the periods presented are summarized below:

- *Share repurchases and dividend payments* — Our 2011, 2010 and 2009 share repurchases and dividend payments have been made in accordance with capital allocation programs approved by our Board of Directors.

We paid \$575 million for share repurchases in 2011, compared with \$501 million in 2010 and \$226 million in 2009. We repurchased approximately 17 million, 15 million and 7 million shares of our common stock in 2011, 2010 and 2009, respectively. We did not repurchase shares during the first half of 2009 given the state of the economy and the financial markets. In the second half of 2009, we resumed repurchases of our common stock following improvements in the economy and capital markets.

We paid an aggregate of \$637 million in cash dividends during 2011, compared with \$604 million in 2010 and \$569 million in 2009. The increase in dividend payments is due to our quarterly per share dividend increasing from \$0.29 in 2009, to \$0.315 in 2010 and to \$0.34 in 2011, and has been offset in part by a reduction in our common stock outstanding as a result of our share repurchase programs.

In December 2011, we announced that our Board of Directors expects to increase the per share quarterly dividend from \$0.34 to \$0.355 for dividends declared in 2012. However, all future dividend declarations are at the discretion of the Board of Directors, and depend on various factors, including our net earnings, financial condition, cash required for future business plans and other factors the Board of Directors may deem relevant. In December 2011, the Board of Directors approved up to \$500 million in share repurchases for 2012. However, future share repurchases will be made at the discretion of management, and will depend on factors similar to those considered by the Board of Directors in making dividend declarations.

- *Proceeds from the exercise of common stock options* — The exercise of common stock options and the related excess tax benefits generated a total of \$45 million of financing cash inflows during 2011 compared with \$54 million during 2010 and \$20 million during 2009.
- *Net debt repayments* — Net debt borrowings were \$698 million in 2011, net debt repayments were \$204 million in 2010 and net debt borrowings were \$414 million in 2009. The following summarizes our most significant cash borrowings and debt repayments made during each year (in millions):

| | <u>Years Ended December 31,</u> | | |
|--|---------------------------------|------------------|------------------|
| | <u>2011</u> | <u>2010</u> | <u>2009</u> |
| <i>Borrowings:</i> | | | |
| Revolving credit facility(a) | \$ 150 | \$ — | \$ — |
| Canadian credit facility | 137 | 316 | 364 |
| Senior notes | 893 | 592 | 1,385 |
| Capital leases and other | <u>21</u> | <u>—</u> | <u>—</u> |
| | <u>\$1,201</u> | <u>\$ 908</u> | <u>\$ 1,749</u> |
| <i>Repayments:</i> | | | |
| Revolving credit facility(a) | \$ — | \$ — | \$ (310) |
| Canadian credit facility | (214) | (372) | (395) |
| Senior notes | (147) | (600) | (500) |
| Tax exempt bonds | (25) | (52) | (65) |
| Tax exempt project bonds | (30) | (39) | (39) |
| Capital leases and other debt | <u>(87)</u> | <u>(49)</u> | <u>(26)</u> |
| | <u>\$ (503)</u> | <u>\$(1,112)</u> | <u>\$(1,335)</u> |
| <i>Net borrowings (repayments)</i> | <u>\$ 698</u> | <u>\$ (204)</u> | <u>\$ 414</u> |

- (a) Due to the short-term maturities of the borrowings under the revolving credit facility, we have reported these cash flows on a net basis in the Consolidated Statement of Cash Flows in accordance with accounting principles generally accepted in the U.S.

This summary excludes the impacts of non-cash borrowings and debt repayments. For the years ended December 31, 2011 and 2009, these non-cash financing activities were primarily associated with our tax-exempt bond financings. Proceeds from tax-exempt bond issuances, net of principal repayments made directly from trust funds, were \$100 million and \$105 million, respectively. During the year ended December 31, 2010, we did not have any tax-exempt bond financings; however, we did have a \$215 million non-cash increase in our debt obligations as a result of the issuance of a note payable in return for a noncontrolling interest in a limited liability company established to invest in and manage low-income housing properties. This investment is discussed in detail in Note 9 to the Consolidated Financial Statements.

- *Other* — Net cash used in other financing activities was \$46 million in 2011 and \$50 million in 2009 while net cash provided from other financing activities was \$18 million in 2010. These activities are primarily attributable to changes in our accrued liabilities for checks written in excess of cash balances due to the timing of cash deposits or payments. During 2011, the cash used for these activities included \$7 million of financing costs paid in May to amend and restate our \$2.0 billion revolving credit facility. The cash provided by changes in our accrued liabilities for checks written in excess of cash balances in 2010 was offset, in part, by \$13 million of financing costs paid in June to initially execute our \$2.0 billion revolving credit facility.

Summary of Contractual Obligations

The following table summarizes our contractual obligations as of December 31, 2011 and the anticipated effect of these obligations on our liquidity in future years (in millions):

| | <u>2012</u> | <u>2013</u> | <u>2014</u> | <u>2015</u> | <u>2016</u> | <u>Thereafter</u> | <u>Total</u> |
|---|----------------|--------------|--------------|--------------|--------------|-------------------|-----------------|
| Recorded Obligations: | | | | | | | |
| Expected environmental liabilities(a) | | | | | | | |
| Final capping, closure and post-closure | \$ 123 | \$ 98 | \$ 86 | \$114 | \$ 95 | \$1,993 | \$ 2,509 |
| Environmental remediation | <u>38</u> | <u>26</u> | <u>27</u> | <u>24</u> | <u>12</u> | <u>138</u> | <u>265</u> |
| | 161 | 124 | 113 | 138 | 107 | 2,131 | 2,774 |
| Debt payments(b),(c),(d) | 918 | 210 | 460 | 455 | 696 | 6,924 | 9,663 |
| Unrecorded Obligations:(e) | | | | | | | |
| Non-cancelable operating lease obligations | 91 | 77 | 68 | 56 | 45 | 238 | 575 |
| Estimated unconditional purchase obligations(f) | <u>148</u> | <u>143</u> | <u>47</u> | <u>36</u> | <u>29</u> | <u>237</u> | <u>640</u> |
| Anticipated liquidity impact as of December 31, 2011 | <u>\$1,318</u> | <u>\$554</u> | <u>\$688</u> | <u>\$685</u> | <u>\$877</u> | <u>\$9,530</u> | <u>\$13,652</u> |

- (a) Environmental liabilities include final capping, closure, post-closure and environmental remediation costs. The amounts included here reflect environmental liabilities recorded in our Consolidated Balance Sheet as of December 31, 2011 without the impact of discounting and inflation. Our recorded environmental liabilities for final capping, closure and post-closure will increase as we continue to place additional tons within the permitted airspace at our landfills.
- (b) The amounts reported here represent the scheduled principal payments related to our long-term debt, excluding related interest. Refer to Note 7 to the Consolidated Financial Statements for information regarding interest rates.
- (c) Our debt obligations as of December 31, 2011 include \$305 million of tax-exempt bonds subject to re-pricing within the next twelve months, which is prior to their scheduled maturities. If the re-offerings of the bonds are unsuccessful, then the bonds can be put to us, requiring immediate repayment. We have classified the anticipated cash flows for these contractual obligations based on the scheduled maturity of the borrowing for purposes of this disclosure. For additional information regarding the classification of these borrowings in our Consolidated Balance Sheet as of December 31, 2011, refer to Note 7 to the Consolidated Financial Statements.
- (d) Our recorded debt obligations include non-cash adjustments associated with discounts, premiums and fair value adjustments for interest rate hedging activities. These amounts have been excluded here because they will not result in an impact to our liquidity in future periods.
- (e) Our unrecorded obligations represent operating lease obligations and purchase commitments from which we expect to realize an economic benefit in future periods. We have also made certain guarantees, as discussed in Note 11 to the Consolidated Financial Statements, that we do not expect to materially affect our current or future financial position, results of operations or liquidity.
- (f) Our unconditional purchase obligations are for various contractual obligations that we generally incur in the ordinary course of our business. Certain of our obligations are quantity driven. For contracts that require us to purchase minimum quantities of goods or services, we have estimated our future minimum obligations based on the current market values of the underlying products or services. Accordingly, the amounts reported in the table are not necessarily indicative of our actual cash flow obligations. See Note 11 to the Consolidated Financial Statements for discussion of the nature and terms of our unconditional purchase obligations.

Liquidity Impacts of Uncertain Tax Positions

As discussed in Note 9 of our Consolidated Financial Statements, we have liabilities associated with unrecognized tax benefits and related interest. These liabilities are primarily included as a component of long-term “Other liabilities” in our Consolidated Balance Sheet because the Company generally does not anticipate that settlement of the liabilities will require payment of cash within the next twelve months. We are not able to reasonably estimate when we would make any cash payments required to settle these liabilities, but do not believe that the ultimate settlement of our obligations will materially affect our liquidity.

Off-Balance Sheet Arrangements

We are party to guarantee arrangements with unconsolidated entities as discussed in the *Guarantees* section of Note 11 to the Consolidated Financial Statements. These arrangements have not materially affected our financial position, results of operations or liquidity during the year ended December 31, 2011 nor are they expected to have a material impact on our future financial position, results of operations or liquidity.

Inflation

While inflationary increases in costs, including the cost of diesel fuel, have affected our operating margins in recent years, we believe that inflation generally has not had, and in the near future is not expected to have, any material adverse effect on our results of operations. However, as of December 31, 2011, over 17% of our collection revenues are generated under long-term agreements with price adjustments based on various indices intended to measure inflation. Additionally, management’s estimates associated with inflation have had, and will continue to have, an impact on our accounting for landfill and environmental remediation liabilities.

New Accounting Pronouncements

Fair Value Measurements — In May 2011, the FASB amended authoritative guidance associated with fair value measurements. This amended guidance defines certain requirements for measuring fair value and for disclosing information about fair value measurements in accordance with U.S. generally accepted accounting principles. The amendments to authoritative guidance associated with fair value measurements were effective for the Company on January 1, 2012 and are to be applied prospectively. We do not expect that the adoption of this guidance will have a material impact on our consolidated financial statements.

Item 7A. Quantitative and Qualitative Disclosures about Market Risk.

In the normal course of business, we are exposed to market risks, including changes in interest rates, Canadian currency rates and certain commodity prices. From time to time, we use derivatives to manage some portion of these risks. Our derivatives are agreements with independent counterparties that provide for payments based on a notional amount. As of December 31, 2011, all of our derivative transactions were related to actual or anticipated economic exposures. We are exposed to credit risk in the event of non-performance by our derivative counterparties. However, we monitor our derivative positions by regularly evaluating our positions and the creditworthiness of the counterparties.

Interest Rate Exposure — Our exposure to market risk for changes in interest rates relates primarily to our financing activities, although our interest costs can also be significantly affected by our on-going financial assurance needs, which are discussed in the *Financial Assurance and Insurance Obligations* section of Item 1.

As of December 31, 2011, we had \$9.7 billion of long-term debt when excluding the impacts of accounting for fair value adjustments attributable to interest rate derivatives, discounts and premiums. The effective interest rates of approximately \$2.2 billion of our outstanding debt obligations are subject to change during 2012. The most significant components of our variable-rate debt obligations are (i) \$1 billion of “receive fixed, pay variable” interest rate swaps associated with outstanding fixed-rate senior notes; (ii) \$611 million of tax-exempt bonds that are subject to re-pricing on either a daily or weekly basis through a remarketing process; (iii) \$305 million of tax-exempt bonds with term interest rate periods that are subject to re-pricing within twelve months; (iv) \$150 million of borrowings outstanding under our \$2.0 billion revolving credit facility; and

(v) U.S.\$137 million of outstanding advances under our Canadian Credit Facility. We currently estimate that a 100 basis point increase in the interest rates of our outstanding variable-rate debt obligations would increase our 2012 interest expense by approximately \$18 million. As of December 31, 2010, the effective interest rates of approximately \$1.8 billion of our outstanding debt obligations were subject to change within twelve months.

Our remaining outstanding debt obligations have fixed interest rates through either the scheduled maturity of the debt or, for certain of our “fixed-rate” tax exempt bonds, through the end of a term interest rate period that exceeds twelve months. In addition, at December 31, 2011, we had forward-starting interest rate swaps with a notional amount of \$375 million. The fair value of our fixed-rate debt obligations and various interest rate derivative instruments can increase or decrease significantly if market interest rates change.

We have performed sensitivity analyses to determine how market rate changes might affect the fair value of our market risk-sensitive derivatives and related positions. These analyses are inherently limited because they reflect a singular, hypothetical set of assumptions. Actual market movements may vary significantly from our assumptions. An instantaneous, one percentage point increase in interest rates across all maturities and applicable yield curves attributable to these instruments would have decreased the fair value of our combined debt and interest rate derivative positions by approximately \$805 million at December 31, 2011.

We are also exposed to interest rate market risk because we have significant cash and cash equivalent balances as well as assets held in restricted trust funds and escrow accounts. These assets are generally invested in high quality, liquid instruments including money market funds that invest in U.S. government obligations with original maturities of three months or less. Because of the short terms to maturity of these investments, we believe that our exposure to changes in fair value due to interest rate fluctuations is insignificant.

Commodity Price Exposure — In the normal course of our business, we are subject to operating agreements that expose us to market risks arising from changes in the prices for commodities such as diesel fuel; recyclable materials, including old corrugated cardboard, old newsprint and plastics; and electricity, which generally correlates with natural gas prices in many of the markets in which we operate. With the exception of electricity commodity derivatives, which are discussed below, we generally have not entered into derivatives to hedge the risks associated with changes in the market prices of these commodities during the three years ended December 31, 2011. Alternatively, we attempt to manage these risks through operational strategies that focus on capturing our costs in the prices we charge our customers for the services provided. Accordingly, as the market prices for these commodities increase or decrease, our revenues also increase or decrease.

During 2011, approximately 54% of the electricity revenue at our waste-to-energy facilities was subject to current market rates, and we currently expect that nearly 56% of our electricity revenues at our waste-to-energy facilities will be at market rates by the end of 2012. Our exposure to variability associated with changes in market prices for electricity has increased over the last few years as long-term power purchase agreements have expired. The energy markets have changed significantly since the expiring contracts were executed and we have found that the current market structure does not support medium- and long-term electricity contracts. As we renegotiate our power-purchase agreements, we expect that a more substantial portion of our energy sales at our waste-to-energy facilities will be based on variable market rates. Accordingly, in 2010 we implemented a more actively managed energy program, which includes a hedging strategy intended to decrease the exposure of our revenues to volatility due to market prices for electricity. Refer to Note 8 of the Consolidated Financial Statements for additional information regarding our electricity commodity derivatives.

Currency Rate Exposure — We have operations in Canada and investments in China and the United Kingdom. From time to time, we use currency derivatives to mitigate the impact of currency translation on cash flows of intercompany Canadian-currency denominated debt transactions. Our foreign currency derivatives have not materially affected our financial position or results of operations for the periods presented. In addition, while changes in foreign currency exchange rates could significantly affect the fair value of our foreign currency derivatives, we believe these changes in fair value would not have a material impact to the Company. Refer to Note 8 of the Consolidated Financial Statements for additional information regarding our foreign currency derivatives. The foreign currency exposure associated with our investments in China and the United Kingdom has not been material.

Item 8. *Financial Statements and Supplementary Data.*

**INDEX TO
CONSOLIDATED FINANCIAL STATEMENTS**

| | <u>Page</u> |
|--|-------------|
| Management’s Report on Internal Control Over Financial Reporting | 67 |
| Reports of Independent Registered Public Accounting Firm | 68 |
| Consolidated Balance Sheets as of December 31, 2011 and 2010 | 70 |
| Consolidated Statements of Operations for the Years Ended December 31, 2011, 2010 and 2009 | 71 |
| Consolidated Statements of Cash Flows for the Years Ended December 31, 2011, 2010 and 2009 | 72 |
| Consolidated Statements of Changes in Equity for the Years Ended December 31, 2011, 2010 and 2009 .. | 73 |
| Notes to Consolidated Financial Statements | 75 |

MANAGEMENT'S REPORT ON INTERNAL CONTROL OVER FINANCIAL REPORTING

Management of the Company, including the principal executive and financial officers, is responsible for establishing and maintaining adequate internal control over financial reporting, as defined in Rules 13a-15(f) and 15d-15(f) of the Securities Exchange Act of 1934, as amended. Our internal controls are designed to provide reasonable assurance as to the reliability of our financial reporting and the preparation of the consolidated financial statements for external purposes in accordance with accounting principles generally accepted in the United States and includes those policies and procedures that:

- i. pertain to the maintenance of records that in reasonable detail accurately and fairly reflect the transactions and dispositions of the assets of the issuer;
- ii. provide reasonable assurance that transactions are recorded as necessary to permit preparation of financial statements in accordance with generally accepted accounting principles, and that receipts and expenditures of the issuer are being made only in accordance with authorizations of management and directors of the issuer; and
- iii. provide reasonable assurance regarding prevention or timely detection of unauthorized acquisition, use or disposition of the issuer's assets that could have a material effect on the financial statements.

Because of its inherent limitations, internal control over financial reporting may not prevent or detect misstatements. Also, projections of any evaluation of effectiveness to future periods are subject to risk that controls may become inadequate because of changes in conditions, or that the degree of compliance with the policies or procedures may deteriorate.

Management of the Company assessed the effectiveness of our internal control over financial reporting as of December 31, 2011 based on the Internal Control — Integrated Framework issued by the Committee of Sponsoring Organizations of the Treadway Commission. Management has excluded from its assessment the internal controls of Oakleaf Global Holdings, which was acquired in July 2011 and, excluding goodwill, accounted for approximately 1% of our consolidated total assets at December 31, 2011 and 2% of our consolidated total operating revenues for the year ended December 31, 2011. Based on its assessment, management has concluded that our internal control over financial reporting was effective as of December 31, 2011.

The effectiveness of our internal control over financial reporting has been audited by Ernst & Young LLP, the independent registered public accounting firm that audited our consolidated financial statements, as stated in their report which is included herein.

REPORT OF INDEPENDENT REGISTERED PUBLIC ACCOUNTING FIRM

The Board of Directors and Stockholders of Waste Management, Inc.

We have audited Waste Management, Inc.'s internal control over financial reporting as of December 31, 2011, based on criteria established in Internal Control-Integrated Framework issued by the Committee of Sponsoring Organizations of the Treadway Commission (the COSO criteria). Waste Management, Inc.'s management is responsible for maintaining effective internal control over financial reporting, and for its assessment of the effectiveness of internal control over financial reporting included in the accompanying Management's Report on Internal Control Over Financial Reporting. Our responsibility is to express an opinion on the company's internal control over financial reporting based on our audit.

We conducted our audit in accordance with the standards of the Public Company Accounting Oversight Board (United States). Those standards require that we plan and perform the audit to obtain reasonable assurance about whether effective internal control over financial reporting was maintained in all material respects. Our audit included obtaining an understanding of internal control over financial reporting, assessing the risk that a material weakness exists, testing and evaluating the design and operating effectiveness of internal control based on the assessed risk, and performing such other procedures as we considered necessary in the circumstances. We believe that our audit provides a reasonable basis for our opinion.

A company's internal control over financial reporting is a process designed to provide reasonable assurance regarding the reliability of financial reporting and the preparation of financial statements for external purposes in accordance with generally accepted accounting principles. A company's internal control over financial reporting includes those policies and procedures that (1) pertain to the maintenance of records that, in reasonable detail, accurately and fairly reflect the transactions and dispositions of the assets of the company; (2) provide reasonable assurance that transactions are recorded as necessary to permit preparation of financial statements in accordance with generally accepted accounting principles, and that receipts and expenditures of the company are being made only in accordance with authorizations of management and directors of the company; and (3) provide reasonable assurance regarding prevention or timely detection of unauthorized acquisition, use, or disposition of the company's assets that could have a material effect on the financial statements.

Because of its inherent limitations, internal control over financial reporting may not prevent or detect misstatements. Also, projections of any evaluation of effectiveness to future periods are subject to the risk that controls may become inadequate because of changes in conditions, or that the degree of compliance with the policies or procedures may deteriorate.

As indicated in the accompanying Management's Report on Internal Control Over Financial Reporting, management's assessment of and conclusion on the effectiveness of internal control over financial reporting did not include the internal controls of Oakleaf Global Holdings, which is included in the 2011 consolidated financial statements of Waste Management, Inc. and, excluding goodwill, constituted 1% of consolidated total assets as of December 31, 2011 and 2% of consolidated total operating revenues for the year then ended. Our audit of internal control over financial reporting of Waste Management, Inc. also did not include an evaluation of the internal control over financial reporting of Oakleaf Global Holdings.

In our opinion, Waste Management, Inc. maintained, in all material respects, effective internal control over financial reporting as of December 31, 2011, based on the COSO criteria.

We also have audited, in accordance with the standards of the Public Company Accounting Oversight Board (United States), the consolidated balance sheets of Waste Management, Inc. as of December 31, 2011 and 2010, and the related consolidated statements of operations, cash flows, and changes in equity for each of the three years in the period ended December 31, 2011, and our report dated February 16, 2012 expressed an unqualified opinion thereon.

ERNST & YOUNG LLP

Houston, Texas
February 16, 2012

REPORT OF INDEPENDENT REGISTERED PUBLIC ACCOUNTING FIRM

The Board of Directors and Stockholders of Waste Management, Inc.

We have audited the accompanying consolidated balance sheets of Waste Management, Inc. (the “Company”) as of December 31, 2011 and 2010, and the related consolidated statements of operations, cash flows, and changes in equity for each of the three years in the period ended December 31, 2011. These financial statements are the responsibility of the Company’s management. Our responsibility is to express an opinion on these financial statements based on our audits.

We conducted our audits in accordance with the standards of the Public Company Accounting Oversight Board (United States). Those standards require that we plan and perform the audit to obtain reasonable assurance about whether the financial statements are free of material misstatement. An audit includes examining, on a test basis, evidence supporting the amounts and disclosures in the financial statements. An audit also includes assessing the accounting principles used and significant estimates made by management, as well as evaluating the overall financial statement presentation. We believe that our audits provide a reasonable basis for our opinion.

In our opinion, the financial statements referred to above present fairly, in all material respects, the consolidated financial position of Waste Management, Inc. at December 31, 2011 and 2010, and the consolidated results of its operations and its cash flows for each of the three years in the period ended December 31, 2011, in conformity with U.S. generally accepted accounting principles.

As discussed in Note 2 to the consolidated financial statements, effective January 1, 2010, the Company adopted certain provisions of ASC Topic 810, “Consolidation” related to the consolidation of variable interest entities.

We also have audited, in accordance with the standards of the Public Company Accounting Oversight Board (United States), Waste Management, Inc.’s internal control over financial reporting as of December 31, 2011, based on criteria established in Internal Control-Integrated Framework issued by the Committee of Sponsoring Organizations of the Treadway Commission and our report dated February 16, 2012 expressed an unqualified opinion thereon.

ERNST & YOUNG LLP

Houston, Texas
February 16, 2012

WASTE MANAGEMENT, INC.
CONSOLIDATED BALANCE SHEETS
(In Millions, Except Share and Par Value Amounts)

| | December 31, | |
|---|-----------------|-----------------|
| | 2011 | 2010 |
| ASSETS | | |
| Current assets: | | |
| Cash and cash equivalents | \$ 258 | \$ 539 |
| Accounts receivable, net of allowance for doubtful accounts of \$29 and \$26, respectively | 1,631 | 1,510 |
| Other receivables | 144 | 146 |
| Parts and supplies | 153 | 130 |
| Deferred income taxes | 78 | 40 |
| Other assets | <u>115</u> | <u>117</u> |
| Total current assets | 2,379 | 2,482 |
| Property and equipment, net of accumulated depreciation and amortization of \$15,308 and \$14,690, respectively | 12,242 | 11,868 |
| Goodwill | 6,215 | 5,726 |
| Other intangible assets, net | 457 | 295 |
| Investments in unconsolidated entities | 637 | 471 |
| Other assets | <u>639</u> | <u>634</u> |
| Total assets | <u>\$22,569</u> | <u>\$21,476</u> |
| LIABILITIES AND EQUITY | | |
| Current liabilities: | | |
| Accounts payable | \$ 838 | \$ 692 |
| Accrued liabilities | 1,129 | 1,100 |
| Deferred revenues | 470 | 460 |
| Current portion of long-term debt | <u>631</u> | <u>233</u> |
| Total current liabilities | 3,068 | 2,485 |
| Long-term debt, less current portion | 9,125 | 8,674 |
| Deferred income taxes | 1,884 | 1,662 |
| Landfill and environmental remediation liabilities | 1,404 | 1,402 |
| Other liabilities | <u>698</u> | <u>662</u> |
| Total liabilities | <u>16,179</u> | <u>14,885</u> |
| Commitments and contingencies | | |
| Equity: | | |
| Waste Management, Inc. stockholders' equity: | | |
| Common stock, \$0.01 par value; 1,500,000,000 shares authorized; 630,282,461 shares issued | 6 | 6 |
| Additional paid-in capital | 4,561 | 4,528 |
| Retained earnings | 6,721 | 6,400 |
| Accumulated other comprehensive income | 172 | 230 |
| Treasury stock at cost, 169,749,709 and 155,235,711 shares, respectively | <u>(5,390)</u> | <u>(4,904)</u> |
| Total Waste Management, Inc. stockholders' equity | 6,070 | 6,260 |
| Noncontrolling interests | <u>320</u> | <u>331</u> |
| Total equity | <u>6,390</u> | <u>6,591</u> |
| Total liabilities and equity | <u>\$22,569</u> | <u>\$21,476</u> |

See notes to Consolidated Financial Statements.

WASTE MANAGEMENT, INC.
CONSOLIDATED STATEMENTS OF OPERATIONS
(In Millions, Except per Share Amounts)

| | <u>Years Ended December 31,</u> | | |
|--|---------------------------------|----------------|----------------|
| | <u>2011</u> | <u>2010</u> | <u>2009</u> |
| Operating revenues: | | | |
| Service revenues | \$11,852 | \$11,371 | \$11,093 |
| Tangible product revenues | <u>1,526</u> | <u>1,144</u> | <u>698</u> |
| Total operating revenues | <u>13,378</u> | <u>12,515</u> | <u>11,791</u> |
| Costs and expenses: | | | |
| Operating costs (exclusive of depreciation and amortization shown below): | | | |
| Cost of services | 7,254 | 6,854 | 6,620 |
| Cost of tangible products | <u>1,287</u> | <u>970</u> | <u>621</u> |
| Total operating costs | 8,541 | 7,824 | 7,241 |
| Selling, general and administrative | 1,551 | 1,461 | 1,364 |
| Depreciation and amortization | 1,229 | 1,194 | 1,166 |
| Restructuring | 19 | (2) | 50 |
| (Income) expense from divestitures, asset impairments and unusual items .. | <u>10</u> | <u>(78)</u> | <u>83</u> |
| | <u>11,350</u> | <u>10,399</u> | <u>9,904</u> |
| Income from operations | <u>2,028</u> | <u>2,116</u> | <u>1,887</u> |
| Other income (expense): | | | |
| Interest expense | (481) | (473) | (426) |
| Interest income | 8 | 4 | 13 |
| Equity in net losses of unconsolidated entities | (31) | (21) | (2) |
| Other, net | <u>(4)</u> | <u>5</u> | <u>1</u> |
| | <u>(508)</u> | <u>(485)</u> | <u>(414)</u> |
| Income before income taxes | 1,520 | 1,631 | 1,473 |
| Provision for income taxes | <u>511</u> | <u>629</u> | <u>413</u> |
| Consolidated net income | 1,009 | 1,002 | 1,060 |
| Less: Net income attributable to noncontrolling interests | <u>48</u> | <u>49</u> | <u>66</u> |
| Net income attributable to Waste Management, Inc. | <u>\$ 961</u> | <u>\$ 953</u> | <u>\$ 994</u> |
| Basic earnings per common share | <u>\$ 2.05</u> | <u>\$ 1.98</u> | <u>\$ 2.02</u> |
| Diluted earnings per common share | <u>\$ 2.04</u> | <u>\$ 1.98</u> | <u>\$ 2.01</u> |
| Cash dividends declared per common share | <u>\$ 1.36</u> | <u>\$ 1.26</u> | <u>\$ 1.16</u> |

See notes to Consolidated Financial Statements.

WASTE MANAGEMENT, INC.
CONSOLIDATED STATEMENTS OF CASH FLOWS
(In Millions)

| | <u>Years Ended December 31,</u> | | |
|--|---------------------------------|----------------|-----------------|
| | <u>2011</u> | <u>2010</u> | <u>2009</u> |
| Cash flows from operating activities: | | | |
| Consolidated net income | \$ 1,009 | \$ 1,002 | \$ 1,060 |
| Adjustments to reconcile consolidated net income to net cash provided by operating activities: | | | |
| Depreciation and amortization | 1,229 | 1,194 | 1,166 |
| Deferred income tax (benefit) provision | 198 | 154 | (94) |
| Interest accretion on landfill liabilities | 84 | 82 | 80 |
| Interest accretion on and discount rate adjustments to environmental remediation liabilities and recovery assets | 23 | 8 | (30) |
| Provision for bad debts | 44 | 41 | 48 |
| Equity-based compensation expense | 45 | 36 | 30 |
| Net gain from disposal of assets | (24) | (22) | (13) |
| Excess tax benefits associated with equity-based transactions | (8) | (9) | (4) |
| Effect of (income) expense from divestitures, asset impairments and unusual items | 10 | (1) | 83 |
| Equity in net losses of unconsolidated entities, net of dividends | 31 | 20 | 2 |
| Change in operating assets and liabilities, net of effects of acquisitions and divestitures: | | | |
| Receivables | (110) | (159) | 29 |
| Other current assets | (23) | 47 | (4) |
| Other assets | 28 | (3) | 20 |
| Accounts payable and accrued liabilities | 65 | (57) | 51 |
| Deferred revenues and other liabilities | <u>(132)</u> | <u>(58)</u> | <u>(62)</u> |
| Net cash provided by operating activities | <u>2,469</u> | <u>2,275</u> | <u>2,362</u> |
| Cash flows from investing activities: | | | |
| Acquisitions of businesses, net of cash acquired | (867) | (407) | (281) |
| Capital expenditures | (1,324) | (1,104) | (1,179) |
| Proceeds from divestitures of businesses (net of cash divested) and other sales of assets | 36 | 44 | 28 |
| Net receipts from restricted trust and escrow accounts | 107 | 48 | 196 |
| Investments in unconsolidated entities | (155) | (173) | (21) |
| Other | <u>18</u> | <u>(14)</u> | <u>7</u> |
| Net cash used in investing activities | <u>(2,185)</u> | <u>(1,606)</u> | <u>(1,250)</u> |
| Cash flows from financing activities: | | | |
| New borrowings | 1,201 | 908 | 1,749 |
| Debt repayments | (503) | (1,112) | (1,335) |
| Common stock repurchases | (575) | (501) | (226) |
| Cash dividends | (637) | (604) | (569) |
| Exercise of common stock options | 45 | 54 | 20 |
| Excess tax benefits associated with equity-based transactions | 8 | 9 | 4 |
| Distributions paid to noncontrolling interests | (59) | (45) | (50) |
| Other | <u>(46)</u> | <u>18</u> | <u>(50)</u> |
| Net cash used in financing activities | <u>(566)</u> | <u>(1,273)</u> | <u>(457)</u> |
| Effect of exchange rate changes on cash and cash equivalents | <u>1</u> | <u>3</u> | <u>5</u> |
| Increase (decrease) in cash and cash equivalents | (281) | (601) | 660 |
| Cash and cash equivalents at beginning of year | <u>539</u> | <u>1,140</u> | <u>480</u> |
| Cash and cash equivalents at end of year | <u>\$ 258</u> | <u>\$ 539</u> | <u>\$ 1,140</u> |

See notes to Consolidated Financial Statements.

WASTE MANAGEMENT, INC.
CONSOLIDATED STATEMENTS OF CHANGES IN EQUITY
(In Millions, Except Shares in Thousands)

| | Waste Management, Inc. Stockholders' Equity | | | | | | | | | |
|--|---|-------------------------|--------------|---------|----------------------------------|----------------------|---|----------------|-----------|-----------------------------|
| | Total | Comprehensive Income | Common Stock | | Additional Paid-In Capital | Retained Earnings | Accumulated Other Comprehensive Income (Loss) | Treasury Stock | | Noncontrolling Interests |
| | | | Shares | Amounts | | | Shares | Amounts | | |
| Balance, December 31, 2008 | \$6,185 | | 630,282 | \$ 6 | \$4,558 | \$5,631 | \$ 88 | (139,547) | \$(4,381) | \$283 |
| Comprehensive Income: | | | | | | | | | | |
| Consolidated net income | 1,060 | \$1,060 | — | — | — | 994 | — | — | — | 66 |
| Other comprehensive income (loss), net of taxes: | | | | | | | | | | |
| Unrealized losses resulting from changes in fair value of derivative instruments, net of taxes of \$13 | (21) | (21) | — | — | — | — | (21) | — | — | — |
| Realized losses on derivative instruments reclassified into earnings, net of taxes of \$21 | 32 | 32 | — | — | — | — | 32 | — | — | — |
| Unrealized gains on available-for-sale securities, net of taxes of \$2 | 10 | 10 | — | — | — | — | 4 | — | — | 6 |
| Foreign currency translation adjustments | 99 | 99 | — | — | — | — | 99 | — | — | — |
| Change in funded status of post-retirement benefit obligations, net of taxes of \$4 | 6 | 6 | — | — | — | — | 6 | — | — | — |
| Other comprehensive income (loss) | 126 | 126 | | | | | | | | |
| Comprehensive income | 1,186 | \$1,186 | | | | | | | | |
| Cash dividends declared | (569) | | — | — | — | (569) | — | — | — | — |
| Equity-based compensation transactions, including dividend equivalents, net of taxes | 64 | | — | — | (15) | (3) | — | 2,610 | 82 | — |
| Common stock repurchases | (226) | | — | — | — | — | — | (7,237) | (226) | — |
| Distributions paid to noncontrolling interests | (50) | | — | — | — | — | — | — | — | (50) |
| Other | 1 | | — | — | — | — | — | 12 | — | 1 |
| Balance, December 31, 2009 | \$6,591 | | 630,282 | \$ 6 | \$4,543 | \$6,053 | \$208 | (144,162) | \$(4,525) | \$306 |
| Comprehensive Income: | | | | | | | | | | |
| Consolidated net income | 1,002 | \$1,002 | — | — | — | 953 | — | — | — | 49 |
| Other comprehensive income (loss), net of taxes: | | | | | | | | | | |
| Unrealized losses resulting from changes in fair value of derivative instruments, net of taxes of \$28 | (43) | (43) | — | — | — | — | (43) | — | — | — |
| Realized losses on derivative instruments reclassified into earnings, net of taxes of \$12 | 18 | 18 | — | — | — | — | 18 | — | — | — |
| Unrealized gains on available-for-sale securities, net of taxes of \$2 | 3 | 3 | — | — | — | — | 3 | — | — | — |
| Foreign currency translation adjustments | 49 | 49 | — | — | — | — | 49 | — | — | — |
| Change in funded status of post-retirement benefit obligations, net of taxes of \$3 | (5) | (5) | — | — | — | — | (5) | — | — | — |
| Other comprehensive income (loss) | 22 | 22 | | | | | | | | |
| Comprehensive income | 1,024 | \$1,024 | | | | | | | | |
| Cash dividends declared | (604) | | — | — | — | (604) | — | — | — | — |
| Equity-based compensation transactions, including dividend equivalents, net of taxes | 104 | | — | — | (15) | (2) | — | 3,832 | 121 | — |
| Common stock repurchases | (501) | | — | — | — | — | — | (14,920) | (501) | — |
| Distributions paid to noncontrolling interests | (45) | | — | — | — | — | — | — | — | (45) |
| Noncontrolling interests in acquired businesses | 52 | | — | — | — | — | — | — | — | 52 |
| Deconsolidation of variable interest entities | (31) | | — | — | — | — | — | — | — | (31) |
| Other | 1 | | — | — | — | — | — | 14 | 1 | — |
| Balance, December 31, 2010 | \$6,591 | | 630,282 | \$ 6 | \$4,528 | \$6,400 | \$230 | (155,236) | \$(4,904) | \$331 |

WASTE MANAGEMENT, INC.

CONSOLIDATED STATEMENTS OF CHANGES IN EQUITY — (Continued)
(In Millions, Except Shares in Thousands)

| | Waste Management, Inc. Stockholders' Equity | | | | | | | | | |
|--|---|----------------------|--------------|---------|----------------------------|-------------------|---|----------------|------------|--------------------------|
| | Total | Comprehensive Income | Common Stock | | Additional Paid-In Capital | Retained Earnings | Accumulated Other Comprehensive Income (Loss) | Treasury Stock | | Noncontrolling Interests |
| | | | Shares | Amounts | | | | Shares | Amounts | |
| Balance, December 31, 2010 | \$ 6,591 | | 630,282 | \$ 6 | \$ 4,528 | \$ 6,400 | \$ 230 | (155,236) | \$ (4,904) | \$ 331 |
| Comprehensive Income: | | | | | | | | | | |
| Consolidated net income | 1,009 | \$1,009 | — | — | — | 961 | — | — | — | 48 |
| Other comprehensive income (loss), net of taxes: | | | | | | | | | | |
| Unrealized losses resulting from changes in fair value of derivative instruments, net of taxes of \$20 | (30) | (30) | — | — | — | — | (30) | — | — | — |
| Realized losses on derivative instruments reclassified into earnings, net of taxes of \$1 | 1 | 1 | — | — | — | — | 1 | — | — | — |
| Unrealized losses on available-for-sale securities, net of taxes of \$2 | (3) | (3) | — | — | — | — | (3) | — | — | — |
| Foreign currency translation adjustments | (18) | (18) | — | — | — | — | (18) | — | — | — |
| Change in funded status of post-retirement benefit obligations, net of taxes of \$5 | (8) | (8) | — | — | — | — | (8) | — | — | — |
| Other comprehensive income (loss) | (58) | (58) | | | | | | | | |
| Comprehensive income | 951 | \$ 951 | | | | | | | | |
| Cash dividends declared | (637) | | — | — | — | (637) | — | — | — | — |
| Equity-based compensation transactions, including dividend equivalents, net of taxes | 119 | | — | — | 33 | (3) | — | 2,813 | 89 | — |
| Common stock repurchases | (575) | | — | — | — | — | — | (17,338) | (575) | — |
| Distributions paid to noncontrolling interests | (59) | | — | — | — | — | — | — | — | (59) |
| Other | — | | — | — | — | — | — | 11 | — | — |
| Balance, December 31, 2011 | \$6,390 | | 630,282 | \$ 6 | \$4,561 | \$6,721 | \$172 | (169,750) | \$ (5,390) | \$320 |

See notes to Consolidated Financial Statements.

WASTE MANAGEMENT, INC.
NOTES TO CONSOLIDATED FINANCIAL STATEMENTS
Years Ended December 31, 2011, 2010 and 2009

1. Business

The financial statements presented in this report represent the consolidation of Waste Management, Inc., a Delaware corporation; Waste Management's wholly-owned and majority-owned subsidiaries; and certain variable interest entities for which Waste Management or its subsidiaries are the primary beneficiary as described in Note 20. Waste Management is a holding company and all operations are conducted by its subsidiaries. When the terms "the Company," "we," "us" or "our" are used in this document, those terms refer to Waste Management, Inc., its consolidated subsidiaries and consolidated variable interest entities. When we use the term "WM," we are referring only to Waste Management, Inc., the parent holding company.

We are the leading provider of comprehensive waste management services in North America. Our subsidiaries provide collection, transfer, recycling, and disposal services. We are also a leading developer, operator and owner of waste-to-energy and landfill gas-to-energy facilities in the United States. Our customers include residential, commercial, industrial, and municipal customers throughout North America.

We currently manage and evaluate our principal operations through five Groups. Our four geographic operating Groups, which are comprised of our Eastern, Midwest, Southern and Western Groups, provide collection, transfer, disposal (in both solid waste and hazardous waste landfills) and recycling services. Our fifth Group is the Wheelabrator Group, which provides waste-to-energy services and manages waste-to-energy facilities and independent power production plants. We also provide additional services that are not managed through our five Groups, including the operations of Oakleaf Global Holdings and its primary operations ("Oakleaf") acquired on July 28, 2011, which are presented in this report as "Other." Additional information related to our segments and to our acquisition of Oakleaf can be found in Note 21 and in Note 19, respectively.

2. Accounting Changes and Reclassifications

Accounting Changes

Goodwill Impairment Testing — In September 2011, the Financial Accounting Standards Board ("FASB") amended authoritative guidance associated with goodwill impairment testing. The amended guidance provides companies the option to first assess qualitative factors to determine whether the existence of events or circumstances leads to a determination that it is more likely than not that the fair value of a reporting unit is less than its carrying amount before performing the two-step impairment test. If, after assessing the totality of events or circumstances, an entity determines it is not more likely than not that the fair value of a reporting unit is less than its carrying amount, then performing the two-step impairment test is unnecessary. The amendments are effective for goodwill impairment tests performed for fiscal years beginning after December 15, 2011; however, early adoption was permitted. The Company's early adoption of this guidance in 2011 did not have an impact on our consolidated financial statements. Additional information on impairment testing can be found in Note 3.

Multiple-Deliverable Revenue Arrangements — In October 2009, the FASB amended authoritative guidance associated with multiple-deliverable revenue arrangements. This amended guidance addresses the determination of when individual deliverables within an arrangement are required to be treated as separate units of accounting and modifies the manner in which consideration is allocated across the separately identifiable deliverables. The amendments to authoritative guidance associated with multiple-deliverable revenue arrangements became effective for the Company on January 1, 2011. The new accounting standard has been applied prospectively to arrangements entered into or materially modified after the date of adoption. The adoption of this guidance has not had a material impact on our consolidated financial statements.

Consolidation of Variable Interest Entities — In June 2009, the FASB issued revised authoritative guidance associated with the consolidation of variable interest entities. The new guidance primarily uses a qualitative approach for determining whether an enterprise is the primary beneficiary of a variable interest entity and, is therefore, required to consolidate the entity. This new guidance generally defines the primary beneficiary as the entity that has (i) the power to direct the activities of the variable interest entity that can most significantly impact

WASTE MANAGEMENT, INC.

NOTES TO CONSOLIDATED FINANCIAL STATEMENTS — (Continued)

the entity's performance and (ii) the obligation to absorb losses and the right to receive benefits from the variable interest entity that could be significant from the perspective of the entity. The new guidance also requires that we continually reassess whether we are the primary beneficiary of a variable interest entity rather than conducting a reassessment only upon the occurrence of specific events.

As a result of our implementation of this guidance, effective January 1, 2010, we deconsolidated certain final capping, closure, post-closure and environmental remediation trusts because we share power over significant activities of these trusts with others. Our financial interests in these entities are discussed in Note 20. The deconsolidation of these trusts has not materially affected our financial position, results of operations or cash flows during the periods presented.

Reclassifications

Certain reclassifications have been made to our prior period consolidated financial information in order to conform to the current year presentation.

3. Summary of Significant Accounting Policies

Principles of Consolidation

The accompanying Consolidated Financial Statements include the accounts of WM, its wholly-owned and majority-owned subsidiaries and certain variable interest entities for which we have determined that we are the primary beneficiary. All material intercompany balances and transactions have been eliminated. Investments in entities in which we do not have a controlling financial interest are accounted for under either the equity method or cost method of accounting, as appropriate.

Estimates and Assumptions

In preparing our financial statements, we make numerous estimates and assumptions that affect the accounting for and recognition and disclosure of assets, liabilities, equity, revenues and expenses. We must make these estimates and assumptions because certain information that we use is dependent on future events, cannot be calculated with a high degree of precision from data available or simply cannot be readily calculated based on generally accepted methods. In some cases, these estimates are particularly difficult to determine and we must exercise significant judgment. In preparing our financial statements, the most difficult, subjective and complex estimates and the assumptions that present the greatest amount of uncertainty relate to our accounting for landfills, environmental remediation liabilities, asset impairments, deferred income taxes and reserves associated with our insured and self-insured claims. Each of these items is discussed in additional detail below. Actual results could differ materially from the estimates and assumptions that we use in the preparation of our financial statements.

Cash and Cash Equivalents

Cash and cash equivalents consist primarily of cash on deposit and money market funds that invest in U.S. government obligations with original maturities of three months or less.

Concentrations of Credit Risk

Financial instruments that potentially subject us to concentrations of credit risk consist primarily of cash and cash equivalents, investments held within our trust funds and escrow accounts, accounts receivable and derivative instruments. We make efforts to control our exposure to credit risk associated with these instruments by (i) placing our assets and other financial interests with a diverse group of credit-worthy financial institutions; (ii) holding high-quality financial instruments while limiting investments in any one instrument; and (iii) maintaining strict policies over credit extension that include credit evaluations, credit limits and monitoring procedures, although generally we do not have collateral requirements for credit extensions. We also control our

WASTE MANAGEMENT, INC.

NOTES TO CONSOLIDATED FINANCIAL STATEMENTS — (Continued)

exposure associated with trade receivables by discontinuing service, to the extent allowable, to non-paying customers. However, our overall credit risk associated with trade receivables is limited due to the large number of geographically diverse customers we service. At December 31, 2011 and 2010, no single customer represented greater than 5% of total accounts receivable.

Trade and Other Receivables

Our receivables, which are recorded when billed, when services are performed or when cash is advanced, are claims against third parties that will generally be settled in cash. The carrying value of our receivables, net of the allowance for doubtful accounts, represents the estimated net realizable value. We estimate our allowance for doubtful accounts based on historical collection trends; type of customer, such as municipal or commercial; the age of outstanding receivables; and existing economic conditions. If events or changes in circumstances indicate that specific receivable balances may be impaired, further consideration is given to the collectibility of those balances and the allowance is adjusted accordingly. Past-due receivable balances are written off when our internal collection efforts have been unsuccessful. Also, we recognize interest income on long-term interest-bearing notes receivable as the interest accrues under the terms of the notes.

Parts and Supplies

Parts and supplies consist primarily of spare parts, fuel, tires, lubricants and processed recycling materials. Our parts and supplies are stated at the lower of cost, using the average cost method, or market.

Landfill Accounting

Cost Basis of Landfill Assets — We capitalize various costs that we incur to make a landfill ready to accept waste. These costs generally include expenditures for land (including the landfill footprint and required landfill buffer property); permitting; excavation; liner material and installation; landfill leachate collection systems; landfill gas collection systems; environmental monitoring equipment for groundwater and landfill gas; and directly related engineering, capitalized interest, on-site road construction and other capital infrastructure costs. The cost basis of our landfill assets also includes asset retirement costs, which represent estimates of future costs associated with landfill final capping, closure and post-closure activities. These costs are discussed below.

Final Capping, Closure and Post-Closure Costs — Following is a description of our asset retirement activities and our related accounting:

- *Final Capping* — Involves the installation of flexible membrane liners and geosynthetic clay liners, drainage and compacted soil layers and topsoil over areas of a landfill where total airspace capacity has been consumed. Final capping asset retirement obligations are recorded on a units-of-consumption basis as airspace is consumed related to the specific final capping event with a corresponding increase in the landfill asset. Each final capping event is accounted for as a discrete obligation and recorded as an asset and a liability based on estimates of the discounted cash flows and capacity associated with each final capping event.
- *Closure* — Includes the construction of the final portion of methane gas collection systems (when required), demobilization and routine maintenance costs. These are costs incurred after the site ceases to accept waste, but before the landfill is certified as closed by the applicable state regulatory agency. These costs are recorded as an asset retirement obligation as airspace is consumed over the life of the landfill with a corresponding increase in the landfill asset. Closure obligations are recorded over the life of the landfill based on estimates of the discounted cash flows associated with performing closure activities.
- *Post-Closure* — Involves the maintenance and monitoring of a landfill site that has been certified closed by the applicable regulatory agency. Generally, we are required to maintain and monitor landfill sites for a 30-year period. These maintenance and monitoring costs are recorded as an asset retirement obligation

WASTE MANAGEMENT, INC.

NOTES TO CONSOLIDATED FINANCIAL STATEMENTS — (Continued)

as airspace is consumed over the life of the landfill with a corresponding increase in the landfill asset. Post-closure obligations are recorded over the life of the landfill based on estimates of the discounted cash flows associated with performing post-closure activities.

We develop our estimates of these obligations using input from our operations personnel, engineers and accountants. Our estimates are based on our interpretation of current requirements and proposed regulatory changes and are intended to approximate fair value. Absent quoted market prices, the estimate of fair value is based on the best available information, including the results of present value techniques. In many cases, we contract with third parties to fulfill our obligations for final capping, closure and post-closure. We use historical experience, professional engineering judgment and quoted and actual prices paid for similar work to determine the fair value of these obligations. We are required to recognize these obligations at market prices whether we plan to contract with third parties or perform the work ourselves. In those instances where we perform the work with internal resources, the incremental profit margin realized is recognized as a component of operating income when the work is performed.

Once we have determined the final capping, closure and post-closure costs, we inflate those costs to the expected time of payment and discount those expected future costs back to present value. During the years ended December 31, 2011, 2010 and 2009, we inflated these costs in current dollars until the expected time of payment using an inflation rate of 2.5%. We discount these costs to present value using the credit-adjusted, risk-free rate effective at the time an obligation is incurred, consistent with the expected cash flow approach. Any changes in expectations that result in an upward revision to the estimated cash flows are treated as a new liability and discounted at the current rate while downward revisions are discounted at the historical weighted-average rate of the recorded obligation. As a result, the credit-adjusted, risk-free discount rate used to calculate the present value of an obligation is specific to each individual asset retirement obligation. The weighted-average rate applicable to our asset retirement obligations at December 31, 2011 is between 5.5% and 8.0%, the range of the credit-adjusted, risk-free discount rates effective since we adopted the FASB's authoritative guidance related to asset retirement obligations in 2003. We expect to apply a credit-adjusted, risk-free discount rate of 4.5% to liabilities incurred in the first quarter of 2012.

We record the estimated fair value of final capping, closure and post-closure liabilities for our landfills based on the capacity consumed through the current period. The fair value of final capping obligations is developed based on our estimates of the airspace consumed to date for each final capping event and the expected timing of each final capping event. The fair value of closure and post-closure obligations is developed based on our estimates of the airspace consumed to date for the entire landfill and the expected timing of each closure and post-closure activity. Because these obligations are measured at estimated fair value using present value techniques, changes in the estimated cost or timing of future final capping, closure and post-closure activities could result in a material change in these liabilities, related assets and results of operations. We assess the appropriateness of the estimates used to develop our recorded balances annually, or more often if significant facts change.

Changes in inflation rates or the estimated costs, timing or extent of future final capping, closure and post-closure activities typically result in both (i) a current adjustment to the recorded liability and landfill asset; and (ii) a change in liability and asset amounts to be recorded prospectively over either the remaining capacity of the related discrete final capping event or the remaining permitted and expansion airspace (as defined below) of the landfill. Any changes related to the capitalized and future cost of the landfill assets are then recognized in accordance with our amortization policy, which would generally result in amortization expense being recognized prospectively over the remaining capacity of the final capping event or the remaining permitted and expansion airspace of the landfill, as appropriate. Changes in such estimates associated with airspace that has been fully utilized result in an adjustment to the recorded liability and landfill assets with an immediate corresponding adjustment to landfill airspace amortization expense.

WASTE MANAGEMENT, INC.

NOTES TO CONSOLIDATED FINANCIAL STATEMENTS — (Continued)

During the years ended December 31, 2011, 2010 and 2009, adjustments associated with changes in our expectations for the timing and cost of future final capping, closure and post-closure of fully utilized airspace resulted in \$11 million, \$13 million and \$14 million in net credits to landfill airspace amortization expense, respectively, with the majority of these credits resulting from revised estimates associated with final capping changes. In managing our landfills, our engineers look for ways to reduce or defer our construction costs, including final capping costs. The benefit recognized in these years was generally the result of (i) concerted efforts to improve the operating efficiencies of our landfills and volume declines, both of which have allowed us to delay spending for final capping activities; (ii) effectively managing the cost of final capping material and construction; or (iii) landfill expansions that resulted in reduced or deferred final capping costs.

Interest accretion on final capping, closure and post-closure liabilities is recorded using the effective interest method and is recorded as final capping, closure and post-closure expense, which is included in “Operating” costs and expenses within our Consolidated Statements of Operations.

Amortization of Landfill Assets — The amortizable basis of a landfill includes (i) amounts previously expended and capitalized; (ii) capitalized landfill final capping, closure and post-closure costs; (iii) projections of future purchase and development costs required to develop the landfill site to its remaining permitted and expansion capacity; and (iv) projected asset retirement costs related to landfill final capping, closure and post-closure activities.

Amortization is recorded on a units-of-consumption basis, applying expense as a rate per ton. The rate per ton is calculated by dividing each component of the amortizable basis of a landfill by the number of tons needed to fill the corresponding asset’s airspace. For landfills that we do not own, but operate through operating or lease arrangements, the rate per ton is calculated based on expected capacity to be utilized over the lesser of the contractual term of the underlying agreement or the life of the landfill.

We apply the following guidelines in determining a landfill’s remaining permitted and expansion airspace:

- *Remaining Permitted Airspace* — Our engineers, in consultation with third-party engineering consultants and surveyors, are responsible for determining remaining permitted airspace at our landfills. The remaining permitted airspace is determined by an annual survey, which is used to compare the existing landfill topography to the expected final landfill topography.
- *Expansion Airspace* — We also include currently unpermitted expansion airspace in our estimate of remaining permitted and expansion airspace in certain circumstances. First, to include airspace associated with an expansion effort, we must generally expect the initial expansion permit application to be submitted within one year, and the final expansion permit to be received within five years. Second, we must believe the success of obtaining the expansion permit is likely, considering the following criteria:
 - Personnel are actively working on the expansion of an existing landfill, including efforts to obtain land use and local, state or provincial approvals;
 - It is likely that the approvals will be received within the normal application and processing time periods for approvals in the jurisdiction in which the landfill is located;
 - We have a legal right to use or obtain land to be included in the expansion plan;
 - There are no significant known technical, legal, community, business, or political restrictions or similar issues that could impair the success of such expansion;
 - Financial analysis has been completed, and the results demonstrate that the expansion has a positive financial and operational impact; and
 - Airspace and related costs, including additional closure and post-closure costs, have been estimated based on conceptual design.

WASTE MANAGEMENT, INC.

NOTES TO CONSOLIDATED FINANCIAL STATEMENTS — (Continued)

For unpermitted airspace to be initially included in our estimate of remaining permitted and expansion airspace, the expansion effort must meet all of the criteria listed above. These criteria are evaluated by our field-based engineers, accountants, managers and others to identify potential obstacles to obtaining the permits. Once the unpermitted airspace is included, our policy provides that airspace may continue to be included in remaining permitted and expansion airspace even if certain of these criteria are no longer met as long as we continue to believe we will ultimately obtain the permit, based on the facts and circumstances of a specific landfill. In these circumstances, continued inclusion must be approved through a landfill-specific review process that includes approval by our principal financial officer and a review by the Audit Committee of our Board of Directors on a quarterly basis. Of the 33 landfill sites with expansions at December 31, 2011, 11 landfills required the principal financial officer to approve the inclusion of the unpermitted airspace. Seven of these landfills required approval by our principal financial officer because of community or political opposition that could impede the expansion process. The remaining four landfills required approval primarily due to local zoning restrictions or because the permit application processes do not meet the one- or five-year requirements.

When we include the expansion airspace in our calculations of remaining permitted and expansion airspace, we also include the projected costs for development, as well as the projected asset retirement costs related to final capping, closure and post-closure of the expansion in the amortization basis of the landfill.

Once the remaining permitted and expansion airspace is determined in cubic yards, an airspace utilization factor, or AUF, is established to calculate the remaining permitted and expansion capacity in tons. The AUF is established using the measured density obtained from previous annual surveys and is then adjusted to account for future settlement. The amount of settlement that is forecasted will take into account several site-specific factors including current and projected mix of waste type, initial and projected waste density, estimated number of years of life remaining, depth of underlying waste, anticipated access to moisture through precipitation or recirculation of landfill leachate, and operating practices. In addition, the initial selection of the AUF is subject to a subsequent multi-level review by our engineering group, and the AUF used is reviewed on a periodic basis and revised as necessary. Our historical experience generally indicates that the impact of settlement at a landfill is greater later in the life of the landfill when the waste placed at the landfill approaches its highest point under the permit requirements.

After determining the costs and remaining permitted and expansion capacity at each of our landfills, we determine the per ton rates that will be expensed as waste is received and deposited at the landfill by dividing the costs by the corresponding number of tons. We calculate per ton amortization rates for each landfill for assets associated with each final capping event, for assets related to closure and post-closure activities and for all other costs capitalized or to be capitalized in the future. These rates per ton are updated annually, or more often, as significant facts change.

It is possible that actual results, including the amount of costs incurred, the timing of final capping, closure and post-closure activities, our airspace utilization or the success of our expansion efforts could ultimately turn out to be significantly different from our estimates and assumptions. To the extent that such estimates, or related assumptions, prove to be significantly different than actual results, lower profitability may be experienced due to higher amortization rates or higher expenses, or higher profitability may result if the opposite occurs. Most significantly, if it is determined that expansion capacity should no longer be considered in calculating the recoverability of a landfill asset, we may be required to recognize an asset impairment or incur significantly higher amortization expense. If at any time management makes the decision to abandon the expansion effort, the capitalized costs related to the expansion effort are expensed immediately.

Environmental Remediation Liabilities

We are subject to an array of laws and regulations relating to the protection of the environment. Under current laws and regulations, we may have liabilities for environmental damage caused by operations, or for

WASTE MANAGEMENT, INC.

NOTES TO CONSOLIDATED FINANCIAL STATEMENTS — (Continued)

damage caused by conditions that existed before we acquired a site. These liabilities include potentially responsible party (“PRP”) investigations, settlements, and certain legal and consultant fees, as well as costs directly associated with site investigation and clean up, such as materials, external contractor costs and incremental internal costs directly related to the remedy. We provide for expenses associated with environmental remediation obligations when such amounts are probable and can be reasonably estimated. We routinely review and evaluate sites that require remediation and determine our estimated cost for the likely remedy based on a number of estimates and assumptions.

Where it is probable that a liability has been incurred, we estimate costs required to remediate sites based on site-specific facts and circumstances. We routinely review and evaluate sites that require remediation, considering whether we were an owner, operator, transporter, or generator at the site, the amount and type of waste hauled to the site and the number of years we were associated with the site. Next, we review the same type of information with respect to other named and unnamed PRPs. Estimates of the costs for the likely remedy are then either developed using our internal resources or by third-party environmental engineers or other service providers. Internally developed estimates are based on:

- Management’s judgment and experience in remediating our own and unrelated parties’ sites;
- Information available from regulatory agencies as to costs of remediation;
- The number, financial resources and relative degree of responsibility of other PRPs who may be liable for remediation of a specific site; and
- The typical allocation of costs among PRPs, unless the actual allocation has been determined.

Estimating our degree of responsibility for remediation is inherently difficult. We recognize and accrue for an estimated remediation liability when we determine that such liability is both probable and reasonably estimable. Determining the method and ultimate cost of remediation requires that a number of assumptions be made. There can sometimes be a range of reasonable estimates of the costs associated with the investigation of the extent of environmental impact and identification of likely site-remediation alternatives. In these cases, we use the amount within a range that constitutes our best estimate. If no amount within the range appears to be a better estimate than any other, we use the amount that is the low end of such range. If we used the high ends of such ranges, our aggregate potential liability would be approximately \$150 million higher than the \$273 million recorded in the Consolidated Financial Statements as of December 31, 2011. Our ultimate responsibility may differ materially from current estimates. It is possible that technological, regulatory or enforcement developments, the results of environmental studies, the inability to identify other PRPs, the inability of other PRPs to contribute to the settlements of such liabilities, or other factors could require us to record additional liabilities. Our ongoing review of our remediation liabilities, in light of relevant internal and external facts and circumstances, could result in revisions to our accruals that could cause upward or downward adjustments to income from operations. These adjustments could be material in any given period.

WASTE MANAGEMENT, INC.

NOTES TO CONSOLIDATED FINANCIAL STATEMENTS — (Continued)

Where we believe that both the amount of a particular environmental remediation liability and the timing of the payments are reliably determinable, we inflate the cost in current dollars (by 2.5% at December 31, 2011 and 2010) until the expected time of payment and discount the cost to present value using a risk-free discount rate, which is based on the rate for United States Treasury bonds with a term approximating the weighted average period until settlement of the underlying obligation. We determine the risk-free discount rate and the inflation rate on an annual basis unless interim changes would significantly impact our results of operations. For remedial liabilities that have been discounted, we include interest accretion, based on the effective interest method, in “Operating” costs and expenses in our Consolidated Statements of Operations. The following table summarizes the impacts of revisions in the risk-free discount rate applied to our environmental remediation liabilities and recovery assets during the reported periods (in millions) and the risk-free discount rate applied as of each reporting date:

| | <u>Years Ended December 31,</u> | | |
|--|---------------------------------|-------------|-------------|
| | <u>2011</u> | <u>2010</u> | <u>2009</u> |
| Charge (reduction) to Operating expenses(a) | \$ 17 | \$ 2 | \$ (35) |
| Risk-free discount rate applied to environmental remediation liabilities and recovery assets | 2.00% | 3.50% | 3.75% |

(a) In 2009, \$9 million of the reduction in “Operating” expenses was attributable to noncontrolling interests.

The portion of our recorded environmental remediation liabilities that has never been subject to inflation or discounting, as the amounts and timing of payments are not readily determinable, was \$48 million at December 31, 2011 and \$81 million at December 31, 2010. Had we not inflated and discounted any portion of our environmental remediation liability, the amount recorded would have decreased by \$8 million at December 31, 2011 and increased by \$15 million at December 31, 2010.

Property and Equipment (exclusive of landfills, discussed above)

We record property and equipment at cost. Expenditures for major additions and improvements are capitalized and maintenance activities are expensed as incurred. We depreciate property and equipment over the estimated useful life of the asset using the straight-line method. We assume no salvage value for our depreciable property and equipment. When property and equipment are retired, sold or otherwise disposed of, the cost and accumulated depreciation are removed from our accounts and any resulting gain or loss is included in results of operations as an offset or increase to operating expense for the period.

The estimated useful lives for significant property and equipment categories are as follows (in years):

| | <u>Useful Lives</u> |
|---|---------------------|
| Vehicles — excluding rail haul cars | 3 to 10 |
| Vehicles — rail haul cars | 10 to 20 |
| Machinery and equipment — including containers | 3 to 30 |
| Buildings and improvements — excluding waste-to-energy facilities | 5 to 40 |
| Waste-to-energy facilities and related equipment | up to 50 |
| Furniture, fixtures and office equipment | 3 to 10 |

We include capitalized costs associated with developing or obtaining internal-use software within furniture, fixtures and office equipment. These costs include direct external costs of materials and services used in developing or obtaining the software and internal costs for employees directly associated with the software development project. As of December 31, 2011, capitalized costs for software placed in service, net of accumulated depreciation, were \$112 million. In addition, our furniture, fixtures and office equipment includes

WASTE MANAGEMENT, INC.

NOTES TO CONSOLIDATED FINANCIAL STATEMENTS — (Continued)

\$27 million as of December 31, 2011 and \$51 million as of December 31, 2010 for costs incurred for software under development.

Leases

We lease property and equipment in the ordinary course of our business. Our most significant lease obligations are for property and equipment specific to our industry, including real property operated as a landfill, transfer station or waste-to-energy facility. Our leases have varying terms. Some may include renewal or purchase options, escalation clauses, restrictions, penalties or other obligations that we consider in determining minimum lease payments. The leases are classified as either operating leases or capital leases, as appropriate.

Operating Leases (excluding landfills discussed below) — The majority of our leases are operating leases. This classification generally can be attributed to either (i) relatively low fixed minimum lease payments as a result of real property lease obligations that vary based on the volume of waste we receive or process or (ii) minimum lease terms that are much shorter than the assets' economic useful lives. Management expects that in the normal course of business our operating leases will be renewed, replaced by other leases, or replaced with fixed asset expenditures. Our rent expense during each of the last three years and our future minimum operating lease payments for each of the next five years for which we are contractually obligated as of December 31, 2011 are disclosed in Note 11.

Capital Leases (excluding landfills discussed below) — Assets under capital leases are capitalized using interest rates determined at the inception of each lease and are amortized over either the useful life of the asset or the lease term, as appropriate, on a straight-line basis. The present value of the related lease payments is recorded as a debt obligation. Our future minimum annual capital lease payments are included in our total future debt obligations as disclosed in Note 7.

Landfill Leases — From an operating perspective, landfills that we lease are similar to landfills we own because generally we own the landfill's operating permit and will operate the landfill for the entire lease term, which in many cases is the life of the landfill. As a result, our landfill leases are generally capital leases. The most significant portion of our rental obligations for landfill leases is contingent upon operating factors such as disposal volumes and often there are no contractual minimum rental obligations. Contingent rental obligations are expensed as incurred. For landfill capital leases that provide for minimum contractual rental obligations, we record the present value of the minimum obligation as part of the landfill asset, which is amortized on a units-of-consumption basis over the shorter of the lease term or the life of the landfill.

Acquisitions

We generally recognize assets acquired and liabilities assumed in business combinations, including contingent assets and liabilities, based on fair value estimates as of the date of acquisition.

Contingent Consideration — In certain acquisitions, we agree to pay additional amounts to sellers contingent upon achievement by the acquired businesses of certain negotiated goals, such as targeted revenue levels, targeted disposal volumes or the issuance of permits for expanded landfill airspace. For acquisitions completed beginning in 2009, we have recognized liabilities for these contingent obligations based on their estimated fair value at the date of acquisition with any differences between the acquisition-date fair value and the ultimate settlement of the obligations being recognized as an adjustment to income from operations. For acquisitions completed before 2009, these obligations were recognized as incurred and accounted for as an adjustment to the initial purchase price of the acquired assets.

Acquired Assets and Assumed Liabilities — Assets and liabilities arising from contingencies such as pre-acquisition environmental matters and litigation are recognized at their acquisition-date fair value when their respective fair values can be determined. If the fair values of such contingencies cannot be determined, they are recognized at the acquisition date if the contingencies are probable and an amount can be reasonably estimated.

WASTE MANAGEMENT, INC.

NOTES TO CONSOLIDATED FINANCIAL STATEMENTS — (Continued)

Acquisition-date fair value estimates are revised as necessary and accounted for as an adjustment to income from operations if, and when, additional information regarding these contingencies becomes available to further define and quantify assets acquired and liabilities assumed. Beginning in 2009, all acquisition-related transaction costs have been expensed as incurred. For acquisitions completed before 2009, direct costs incurred for a business combination were accounted for as part of the cost of the acquired business.

Goodwill and Other Intangible Assets

Goodwill is the excess of our purchase cost over the fair value of the net assets of acquired businesses. We do not amortize goodwill, but as discussed in the “Asset Impairments” section below, we assess our goodwill for impairment at least annually.

Other intangible assets consist primarily of customer contracts, customer lists, covenants not-to-compete, licenses, permits (other than landfill permits, as all landfill-related intangible assets are combined with landfill tangible assets and amortized using our landfill amortization policy), and other contracts. Other intangible assets are recorded at cost and are generally amortized using either a 150% declining balance approach or a straight-line basis as we determine appropriate. Customer contracts and customer lists are typically amortized over ten years. Covenants not-to-compete are amortized over the term of the non-compete covenant, which is generally two to five years. Licenses, permits and other contracts are amortized over the definitive terms of the related agreements. If the underlying agreement does not contain definitive terms and the useful life is determined to be indefinite, the asset is not amortized.

Asset Impairments

We monitor the carrying value of our long-lived assets for potential impairment and test the recoverability of such assets whenever events or changes in circumstances indicate that their carrying amounts may not be recoverable. These events or changes in circumstances, including management decisions pertaining to such assets, are referred to as impairment indicators. If an impairment indicator occurs, we perform a test of recoverability by comparing the carrying value of the asset or asset group to its undiscounted expected future cash flows. If cash flows cannot be separately and independently identified for a single asset, we will determine whether an impairment has occurred for the group of assets for which we can identify the projected cash flows. If the carrying values are in excess of undiscounted expected future cash flows, we measure any impairment by comparing the fair value of the asset or asset group to its carrying value. Fair value is generally determined by considering (i) internally developed discounted projected cash flow analysis of the asset or asset group; (ii) actual third-party valuations; and/or (iii) information available regarding the current market for similar assets. If the fair value of an asset or asset group is determined to be less than the carrying amount of the asset or asset group, an impairment in the amount of the difference is recorded in the period that the impairment indicator occurs and is included in the “(Income) expense from divestitures, asset impairments and unusual items” line item in our Consolidated Statement of Operations. Estimating future cash flows requires significant judgment and projections may vary from the cash flows eventually realized, which could impact our ability to accurately assess whether an asset has been impaired.

There are additional considerations for impairments of landfills, goodwill and other indefinite-lived intangible assets, as described below.

Landfills — The assessment of impairment indicators and the recoverability of our capitalized costs associated with landfills and related expansion projects require significant judgment due to the unique nature of the waste industry, the highly regulated permitting process and the sensitive estimates involved. During the review of a landfill expansion application, a regulator may initially deny the expansion application although the expansion permit is ultimately granted. In addition, management may periodically divert waste from one landfill to another to conserve remaining permitted landfill airspace, or a landfill may be required to cease accepting waste, prior to receipt of the expansion permit. However, such events occur in the ordinary course of business in

WASTE MANAGEMENT, INC.

NOTES TO CONSOLIDATED FINANCIAL STATEMENTS — (Continued)

the waste industry and do not necessarily result in impairment of our landfill assets because, after consideration of all facts, such events may not affect our belief that we will ultimately obtain the expansion permit. As a result, our tests of recoverability, which generally make use of a probability-weighted cash flow estimation approach, may indicate that no impairment loss should be recorded. At December 31, 2011, three of our landfill sites in two jurisdictions in the Company's Midwest Group, for which we believe receipt of expansion permits is probable, had ceased accepting waste. The net recorded capitalized landfill asset cost for these three sites was \$469 million at December 31, 2011. We performed tests of recoverability for these landfills and the undiscounted cash flows resulting from our probability-weighted estimation approach significantly exceeded the carrying values of each of these three sites.

Goodwill and Other Indefinite-Lived Intangible Assets — At least annually, and more frequently if warranted, we assess our goodwill and indefinite-lived intangible assets for impairment.

We assess whether a goodwill impairment exists using both qualitative and quantitative assessments. Our qualitative assessment involves determining whether events or circumstances exist that indicate it is more likely than not that the fair value of a reporting unit is less than its carrying amount, including goodwill. If based on this qualitative assessment we determine it is not more likely than not that the fair value of a reporting unit is less than its carrying amount, we will not perform a quantitative assessment.

If the qualitative assessment indicates that it is more likely than not that the fair value of a reporting unit is less than its carrying amount or if we elect not to perform a qualitative assessment, we perform a quantitative assessment or two-step impairment test to determine whether a goodwill impairment exists at the reporting unit. The first step in our quantitative assessment identifies potential impairments by comparing the estimated fair value of each reporting unit to its carrying value, including goodwill. If the carrying value exceeds estimated fair value, there is an indication of potential impairment and the second step is performed to measure the amount of impairment. Fair value is typically estimated using an income approach or a combination of the income approach and market approach when applicable. The income approach is based on the long-term projected future cash flows of our reporting units. We discount the estimated cash flows to present value using a weighted-average cost of capital that considers factors such as market assumptions, the timing of the cash flows and the risks inherent in those cash flows. We believe that this approach is appropriate because it provides a fair value estimate based upon our reporting units' expected long-term performance considering the economic and market conditions that generally affect our business. The market approach estimates fair value by measuring the aggregate market value of publicly-traded companies with similar characteristics to our business as a multiple of their reported cash flows. We then apply that multiple to our reporting units' cash flows to estimate their fair values. We believe that this approach is appropriate because it provides a fair value estimate using valuation inputs from entities with operations and economic characteristics comparable to our reporting units.

Fair value computed by these two methods is arrived at using a number of factors, including projected future operating results, economic projections, anticipated future cash flows, comparable marketplace data and the cost of capital. There are inherent uncertainties related to these factors and to our judgment in applying them to this analysis. However, we believe that these two methods provide a reasonable approach to estimating the fair value of our reporting units.

We assess whether other indefinite-lived intangible asset impairments exist by comparing the fair value of the asset with its carrying value. Fair value is typically estimated using an income approach for the respective asset, as described above. If the carrying value exceeds estimated fair value, an impairment would be recognized in the amount of the excess.

Refer to Note 6 for additional information related to goodwill impairment considerations made during the reported periods.

WASTE MANAGEMENT, INC.

NOTES TO CONSOLIDATED FINANCIAL STATEMENTS — (Continued)

Restricted Trust and Escrow Accounts

As of December 31, 2011, our restricted trust and escrow accounts consist principally of (i) funds deposited for purposes of settling landfill final capping, closure, post-closure and environmental remediation obligations; and (ii) funds received from the issuance of tax-exempt bonds held in trust for the construction of various projects or facilities. As of December 31, 2011 and 2010, we had \$152 million and \$146 million, respectively, of restricted trust and escrow accounts, which are primarily included in long-term “Other assets” in our Consolidated Balance Sheets.

Final Capping, Closure, Post-Closure and Environmental Remediation Funds — At several of our landfills, we provide financial assurance by depositing cash into restricted trust funds or escrow accounts for purposes of settling final capping, closure, post-closure and environmental remediation obligations. Balances maintained in these trust funds and escrow accounts will fluctuate based on (i) changes in statutory requirements; (ii) future deposits made to comply with contractual arrangements; (iii) the ongoing use of funds for qualifying final capping, closure, post-closure and environmental remediation activities; (iv) acquisitions or divestitures of landfills; and (v) changes in the fair value of the financial instruments held in the trust fund or escrow accounts.

Tax-Exempt Bond Funds — We obtain funds from the issuance of industrial revenue bonds for the construction of disposal facilities and for equipment necessary to provide waste management services. Proceeds from these arrangements are directly deposited into trust accounts, and we do not have the ability to use the funds in regular operating activities. Accordingly, these borrowings are treated as non-cash financing activities and are excluded from our Consolidated Statements of Cash Flows. As our construction and equipment expenditures are documented and approved by the applicable bond trustee, the funds are released and we receive a cash reimbursement. These cash reimbursements are reported in the Consolidated Statements of Cash Flows as an investing activity when the cash is released from the trust funds. Generally, the funds are fully expended within a few years of the debt issuance. When the debt matures, we repay our obligation with cash on hand and the debt repayments are included as a financing activity in the Consolidated Statements of Cash Flows.

Investments in Unconsolidated Entities

Investments in unconsolidated entities over which the Company has significant influence are accounted for under the equity method of accounting. Investments in affiliates in which the Company does not have the ability to exert significant influence over the investees’ operating and financing activities are accounted for under the cost method of accounting. The majority of our investments are accounted for under the equity method.

Foreign Currency

We have operations in Canada and investments in China and the United Kingdom. The functional currency of our Canadian subsidiaries is Canadian dollars. The assets and liabilities of our foreign operations are translated to U.S. dollars using the exchange rate at the balance sheet date. Revenues and expenses are translated to U.S. dollars using the average exchange rate during the period. The resulting translation difference is reflected as a component of comprehensive income. The foreign currency exposure associated with our investments has not been material.

Derivative Financial Instruments

We primarily use derivative financial instruments to manage our risk associated with fluctuations in interest rates, foreign currency exchange rates and market prices for electricity. We use interest rate swaps to maintain a strategic portion of our long-term debt obligations at variable, market-driven interest rates. In 2009, we entered into interest rate derivatives in anticipation of senior note issuances planned for 2010 through 2014 to effectively lock in a fixed interest rate for those anticipated issuances. Foreign currency exchange rate derivatives are used to hedge our exposure to changes in exchange rates for anticipated cash transactions between Waste Management Holdings, Inc., a wholly-owned subsidiary (“WM Holdings”), and its Canadian subsidiaries. We use electricity

WASTE MANAGEMENT, INC.

NOTES TO CONSOLIDATED FINANCIAL STATEMENTS — (Continued)

commodity derivatives to mitigate the variability in our revenues and cash flows caused by fluctuations in the market prices for electricity.

We obtain current valuations of our interest rate, foreign currency and electricity commodity hedging instruments from third-party pricing models. The estimated fair values of derivatives used to hedge risks fluctuate over time and should be viewed in relation to the underlying hedged transaction and the overall management of our exposure to fluctuations in the underlying risks. The fair value of derivatives is included in other current assets, other long-term assets, accrued liabilities or other long-term liabilities, as appropriate. Any ineffectiveness present in either fair value or cash flow hedges is recognized immediately in earnings without offset. There was no significant ineffectiveness in 2011, 2010 or 2009.

- *Interest Rate Derivatives* — Our “receive fixed, pay variable” interest rate swaps associated with outstanding fixed-rate senior notes have been designated as fair value hedges for accounting purposes. Accordingly, derivative assets are accounted for as an increase in the carrying value of our underlying debt obligations and derivative liabilities are accounted for as a decrease in the carrying value of our underlying debt instruments. These fair value adjustments are deferred and recognized as an adjustment to interest expense over the remaining term of the hedged instruments. Treasury locks and forward-starting swaps executed in 2009 were designated as cash flow hedges for accounting purposes. Unrealized changes in the fair value of these derivative instruments are recorded in “Accumulated other comprehensive income” within the equity section of our Consolidated Balance Sheets. The associated balance in other comprehensive income is reclassified to earnings as the hedged cash flows occur. The impacts of our use of interest rate derivatives on the carrying value of our debt, accumulated other comprehensive income and interest expense are discussed in Note 8.
- *Foreign Currency Derivatives* — Our foreign currency derivatives have been designated as cash flow hedges for accounting purposes, which results in the unrealized changes in the fair value of the derivative instruments being recorded in “Accumulated other comprehensive income” within the equity section of our Consolidated Balance Sheets. The associated balance in other comprehensive income is reclassified to earnings as the hedged cash flows affect earnings. In each of the periods presented, these derivatives have effectively mitigated the impacts of the hedged transactions, resulting in immaterial impacts to our results of operations for the periods presented. The financial statement impacts of our foreign currency derivatives are discussed in Note 8.
- *Electricity Commodity Derivatives* — Our “receive fixed, pay variable” electricity commodity swaps have been designated as cash flow hedges for accounting purposes. The effective portion of the electricity commodity swap gains or losses is initially reported as a component of “Accumulated other comprehensive income” within the equity section of our Consolidated Balance Sheets and subsequently reclassified into earnings when the forecasted transactions affect earnings. The financial statement impacts of our electricity commodity derivatives are discussed in Note 8.

Insured and Self-Insured Claims

We have retained a significant portion of the risks related to our health and welfare, automobile, general liability and workers’ compensation claims programs. The exposure for unpaid claims and associated expenses, including incurred but not reported losses, generally is estimated with the assistance of external actuaries and by factoring in pending claims and historical trends and data. The gross estimated liability associated with settling unpaid claims is included in “Accrued liabilities” in our Consolidated Balance Sheets if expected to be settled within one year, or otherwise is included in long-term “Other liabilities.” Estimated insurance recoveries related to recorded liabilities are reflected as current “Other receivables” or long-term “Other assets” in our Consolidated Balance Sheets when we believe that the receipt of such amounts is probable.

WASTE MANAGEMENT, INC.

NOTES TO CONSOLIDATED FINANCIAL STATEMENTS — (Continued)

Revenue Recognition

Our revenues are generated from the fees we charge for waste collection, transfer, disposal and recycling services; from the sale of electricity, steam, and landfill gas, which are byproducts of our waste-to-energy and landfill operations; and from the sale of recyclable commodities, oil and gas and organic lawn and garden products. The fees charged for our services are generally defined in our service agreements and vary based on contract-specific terms such as frequency of service, weight, volume and the general market factors influencing a region's rates. The fees we charge for our services generally include fuel surcharges, which are intended to pass through to customers increased direct and indirect costs incurred because of changes in market prices for fuel. We generally recognize revenue as services are performed or products are delivered. For example, revenue typically is recognized as waste is collected, tons are received at our landfills or transfer stations, recycling commodities are delivered or as kilowatts are delivered to a customer by a waste-to-energy facility or independent power production plant.

Tangible product revenues primarily include the sale of recyclable commodities at our material recovery facilities and through our recycling brokerage services and, to a lesser extent, sales of oil and gas and organic lawn and garden products.

We bill for certain services prior to performance. Such services include, among others, certain residential contracts that are billed on a quarterly basis and equipment rentals. These advance billings are included in deferred revenues and recognized as revenue in the period service is provided.

Capitalized Interest

We capitalize interest on certain projects under development, including internal-use software and landfill expansion projects, and on certain assets under construction, including operating landfills, landfill gas-to-energy projects and waste-to-energy facilities. During 2011, 2010 and 2009, total interest costs were \$503 million, \$490 million and \$443 million, respectively, of which \$22 million was capitalized in 2011 and \$17 million was capitalized in both 2010 and 2009. In 2011 and 2010, interest was capitalized primarily for landfill construction costs and landfill gas-to-energy construction projects. The interest capitalized in 2009 was primarily for landfill construction costs.

Income Taxes

The Company is subject to income tax in the United States, Canada and Puerto Rico. Current tax obligations associated with our provision for income taxes are reflected in the accompanying Consolidated Balance Sheets as a component of "Accrued liabilities," and the deferred tax obligations are reflected in "Deferred income taxes."

Deferred income taxes are based on the difference between the financial reporting and tax basis of assets and liabilities. The deferred income tax provision represents the change during the reporting period in the deferred tax assets and deferred tax liabilities, net of the effect of acquisitions and dispositions. Deferred tax assets include tax loss and credit carry-forwards and are reduced by a valuation allowance if, based on available evidence, it is more likely than not that some portion or all of the deferred tax assets will not be realized. Significant judgment is required in assessing the timing and amounts of deductible and taxable items. We establish reserves for uncertain tax positions when, despite our belief that our tax return positions are fully supportable, we believe that certain positions may be challenged and potentially disallowed. When facts and circumstances change, we adjust these reserves through our provision for income taxes.

To the extent interest and penalties may be assessed by taxing authorities on any underpayment of income tax, such amounts have been accrued and are classified as a component of income tax expense in our Consolidated Statements of Operations.

WASTE MANAGEMENT, INC.

NOTES TO CONSOLIDATED FINANCIAL STATEMENTS — (Continued)

Contingent Liabilities

We estimate the amount of potential exposure we may have with respect to claims, assessments and litigation in accordance with accounting principles generally accepted in the United States. We are party to pending or threatened legal proceedings covering a wide range of matters in various jurisdictions. It is difficult to predict the outcome of litigation, as it is subject to many uncertainties. Additionally, it is not always possible for management to make a meaningful estimate of the potential loss or range of loss associated with such contingencies.

Supplemental Cash Flow Information

| Cash paid during the year (in millions): | Years Ended December 31, | | |
|---|--------------------------|-------|-------|
| | 2011 | 2010 | 2009 |
| Interest, net of capitalized interest and periodic settlements from interest rate swap agreements | \$470 | \$477 | \$416 |
| Income taxes | 306 | 547 | 466 |

For the years ended December 31, 2011 and 2009, non-cash activities included proceeds from tax-exempt borrowings, net of principal payments made directly from trust funds, of \$100 million and \$105 million, respectively. During the year ended December 31, 2010, we did not have any tax-exempt borrowings; however, we did have a \$215 million non-cash increase in our debt obligations as a result of the issuance of a note payable in return for a noncontrolling interest in a limited liability company established to invest in and manage low-income housing properties. This investment is discussed in detail in Note 9. Non-cash investing and financing activities are excluded from the Consolidated Statements of Cash Flows.

4. Landfill and Environmental Remediation Liabilities

Liabilities for landfill and environmental remediation costs are presented in the table below (in millions):

| | December 31, 2011 | | | December 31, 2010 | | |
|--------------------------------------|-------------------|---------------------------|----------------|-------------------|---------------------------|----------------|
| | Landfill | Environmental Remediation | Total | Landfill | Environmental Remediation | Total |
| Current (in accrued liabilities) ... | \$ 123 | \$ 38 | \$ 161 | \$ 105 | \$ 43 | \$ 148 |
| Long-term | <u>1,169</u> | <u>235</u> | <u>1,404</u> | <u>1,161</u> | <u>241</u> | <u>1,402</u> |
| | <u>\$1,292</u> | <u>\$273</u> | <u>\$1,565</u> | <u>\$1,266</u> | <u>\$284</u> | <u>\$1,550</u> |

WASTE MANAGEMENT, INC.

NOTES TO CONSOLIDATED FINANCIAL STATEMENTS — (Continued)

The changes to landfill and environmental remediation liabilities for the years ended December 31, 2010 and 2011 are reflected in the table below (in millions):

| | <u>Landfill</u> | <u>Environmental Remediation</u> |
|---|-----------------|--------------------------------------|
| December 31, 2009 | \$1,267 | \$256 |
| Obligations incurred and capitalized | 47 | — |
| Obligations settled | (86) | (36) |
| Interest accretion | 82 | 5 |
| Revisions in cost estimates and interest rate assumptions(a)(b) | (49) | 61 |
| Acquisitions, divestitures and other adjustments | <u>5</u> | <u>(2)</u> |
| December 31, 2010 | \$1,266 | \$284 |
| Obligations incurred and capitalized | 49 | — |
| Obligations settled | (80) | (37) |
| Interest accretion | 84 | 6 |
| Revisions in cost estimates and interest rate assumptions(a)(b) | (30) | 23 |
| Acquisitions, divestitures and other adjustments | <u>3</u> | <u>(3)</u> |
| December 31, 2011 | <u>\$1,292</u> | <u>\$273</u> |

- (a) The amounts reported for our landfill liabilities include reductions of approximately \$50 million and \$30 million for 2010 and 2011, respectively, related to our year-end annual review of final landfill capping, closure and post-closure obligations.
- (b) The amount reported in 2010 for our environmental remediation liabilities includes increased cost estimates associated with environmental remediation obligations, primarily based on a review and evaluation of existing remediation projects. As these remediation projects progressed, more defined plans were developed, resulting in a net increase in the required obligation to reflect the more likely remedies. Additionally, during 2010, the risk-free discount rate used to measure our liabilities decreased from 3.75% at December 31, 2009 to 3.5% at December 31, 2010, resulting in an increase of \$5 million to our environmental remediation liabilities and a corresponding increase to “Operating” expenses.

The amount reported in 2011 for our environmental remediation liabilities primarily relates to the impact of a decrease in the risk-free discount rate used to measure our liabilities from 3.5% at December 31, 2010 to 2.0% at December 31, 2011, resulting in an increase of \$25 million to our environmental remediation liabilities and a corresponding increase to “Operating” expenses. This charge was partially offset by a \$9 million favorable revision to an environmental remediation liability at a closed site based on the estimated cost of the remediation alternative selected by the EPA.

Our recorded liabilities as of December 31, 2011 include the impacts of inflating certain of these costs based on our expectations for the timing of cash settlement and of discounting certain of these costs to present value. Anticipated payments of currently identified environmental remediation liabilities as measured in current dollars are \$38 million in 2012; \$26 million in 2013; \$27 million in 2014; \$24 million in 2015; \$12 million in 2016; and \$138 million thereafter.

At several of our landfills, we provide financial assurance by depositing cash into restricted trust funds or escrow accounts for purposes of settling final capping, closure, post-closure and environmental remediation obligations. Generally, these trust funds are established to comply with statutory requirements and operating agreements and we are the sole beneficiary of the restricted balances. However, certain of the funds have been established for the benefit of both the Company and the host community in which we operate.

WASTE MANAGEMENT, INC.

NOTES TO CONSOLIDATED FINANCIAL STATEMENTS — (Continued)

The fair value of trust funds and escrow accounts for which we are the sole beneficiary was \$123 million at December 31, 2011 and \$124 million as of December 31, 2010. These amounts are included in long-term “Other assets” in our Consolidated Balance Sheet. Our portion of the trusts that have been established for the benefit of both the Company and the host community in which we operate had an aggregate carrying value of \$107 million at December 31, 2011 and \$103 million at December 31, 2010. These amounts are included in “Other receivables” and as long-term “Other assets” in our Consolidated Balance Sheet.

5. Property and Equipment

Property and equipment at December 31 consisted of the following (in millions):

| | <u>2011</u> | <u>2010</u> |
|--|-----------------|-----------------|
| Land | \$ 663 | \$ 651 |
| Landfills | 12,940 | 12,777 |
| Vehicles | 3,705 | 3,588 |
| Machinery and equipment | 3,731 | 3,454 |
| Containers | 2,392 | 2,277 |
| Buildings and improvements | 3,273 | 3,064 |
| Furniture, fixtures and office equipment | <u>846</u> | <u>747</u> |
| | 27,550 | 26,558 |
| Less accumulated depreciation on tangible property and equipment | (8,377) | (7,898) |
| Less accumulated landfill airspace amortization | <u>(6,931)</u> | <u>(6,792)</u> |
| | <u>\$12,242</u> | <u>\$11,868</u> |

Depreciation and amortization expense, including amortization expense for assets recorded as capital leases, was comprised of the following for the years ended December 31 (in millions):

| | <u>2011</u> | <u>2010</u> | <u>2009</u> |
|---|----------------|----------------|----------------|
| Depreciation of tangible property and equipment | \$ 800 | \$ 781 | \$ 779 |
| Amortization of landfill airspace | <u>378</u> | <u>372</u> | <u>358</u> |
| Depreciation and amortization expense | <u>\$1,178</u> | <u>\$1,153</u> | <u>\$1,137</u> |

6. Goodwill and Other Intangible Assets

Goodwill was \$6,215 million as of December 31, 2011 compared with \$5,726 million as of December 31, 2010. The \$489 million increase in goodwill during 2011 was primarily related to consideration paid for acquisitions in excess of identifiable net assets acquired of \$497 million, which includes \$327 million related to our July 2011 acquisition of Oakleaf as discussed in Note 19, partially offset by foreign currency translation and other adjustments.

We incurred no impairment of goodwill as a result of our annual, fourth quarter goodwill impairment tests in 2011, 2010 or 2009. Additionally, we did not encounter any events or changes in circumstances that indicated that an impairment was more likely than not during interim periods in 2011, 2010 or 2009. However, there can be no assurance that goodwill will not be impaired at any time in the future.

WASTE MANAGEMENT, INC.

NOTES TO CONSOLIDATED FINANCIAL STATEMENTS — (Continued)

Our other intangible assets as of December 31, 2011 and 2010 were comprised of the following (in millions):

| | <u>Customer Contracts and Customer Lists</u> | <u>Covenants Not-to- Compete</u> | <u>Licenses, Permits and Other</u> | <u>Total</u> |
|---|--|--|--|---------------|
| December 31, 2011: | | | | |
| Intangible assets | \$ 392 | \$ 91 | \$161 | \$ 644 |
| Less accumulated amortization | <u>(119)</u> | <u>(41)</u> | <u>(27)</u> | <u>(187)</u> |
| | <u>\$ 273</u> | <u>\$ 50</u> | <u>\$134</u> | <u>\$ 457</u> |
| December 31, 2010: | | | | |
| Intangible assets | \$ 228 | \$ 64 | \$147 | \$ 439 |
| Less accumulated amortization | <u>(87)</u> | <u>(31)</u> | <u>(26)</u> | <u>(144)</u> |
| | <u>\$ 141</u> | <u>\$ 33</u> | <u>\$121</u> | <u>\$ 295</u> |

Amortization expense for other intangible assets was \$51 million for 2011, \$41 million for 2010, and \$29 million for 2009. At December 31, 2011, we had \$62 million of intangible assets that are not subject to amortization, which are primarily operating permits that do not have stated expirations or that have routine, administrative renewal processes. Additional information related to intangible assets acquired through 2011 business combinations is included in Note 19. As of December 31, 2011, expected annual amortization expense related to intangible assets is \$66 million in 2012; \$58 million in 2013; \$48 million in 2014; \$42 million in 2015; and \$37 million in 2016.

7. Debt

The following table summarizes the major components of debt at each balance sheet date (in millions) and provides the maturities and interest rate ranges of each major category as of December 31, 2011:

| | <u>2011</u> | <u>2010</u> |
|--|----------------|----------------|
| Revolving credit facility (interest rate of 1.5% at December 31, 2011) | \$ 150 | \$ — |
| Letter of credit facilities | — | — |
| Canadian credit facility (weighted average effective interest rate of 1.8% at December 31, 2011 and 2.2% at December 31, 2010) | 137 | 212 |
| Senior notes and debentures, maturing through 2039, interest rates ranging from 2.60% to 7.75% (weighted average interest rate of 6.0% at December 31, 2011 and 6.5% at December 31, 2010) | 6,228 | 5,452 |
| Tax-exempt bonds maturing through 2041, fixed and variable interest rates ranging from 0.1% to 7.4% (weighted average interest rate of 3.1% at December 31, 2011 and 2010) | 2,771 | 2,696 |
| Tax-exempt project bonds, maturing through 2029, fixed and variable interest rates ranging from 0.1% to 3.4% (weighted average interest rate of 1.3% at December 31, 2011 and 2.5% at December 31, 2010) | 86 | 116 |
| Capital leases and other, maturing through 2055, interest rates up to 12% | <u>384</u> | <u>431</u> |
| Total long-term debt | \$9,756 | \$8,907 |
| Current portion of long-term debt | <u>631</u> | <u>233</u> |
| Long-term debt, less current portion | <u>\$9,125</u> | <u>\$8,674</u> |

WASTE MANAGEMENT, INC.

NOTES TO CONSOLIDATED FINANCIAL STATEMENTS — (Continued)

Debt Classification

As of December 31, 2011, we had (i) \$925 million of debt maturing within twelve months, including \$150 million of borrowings outstanding under the revolving credit facility, U.S.\$137 million of advances outstanding under our Canadian credit facility, \$400 million of 6.375% senior notes that mature in November 2012 and \$168 million of tax-exempt bonds and (ii) \$305 million of fixed-rate tax-exempt borrowings subject to re-pricing within the next twelve months. Under accounting principles generally accepted in the United States, this debt must be classified as current unless we have the intent and ability to refinance it on a long-term basis. We have the intent and ability to refinance \$599 million of this debt on a long-term basis and have classified the remaining \$631 million as current obligations as of December 31, 2011.

As of December 31, 2011, we also have \$565 million of variable-rate tax-exempt bonds and \$46 million of variable-rate tax-exempt project bonds. The interest rates on these bonds are reset on either a daily or weekly basis through a remarketing process. If the remarketing agent is unable to remarket the bonds, the remarketing agent can put the bonds to us. These bonds are supported by letters of credit guaranteeing repayment of the bonds in this event. We classified these borrowings as long-term in our Consolidated Balance Sheet at December 31, 2011 because the borrowings are supported by letters of credit issued under our five-year, \$2.0 billion revolving credit facility, which is long-term.

Access to and Utilization of Credit Facilities

Revolving Credit Facility — In May 2011, we amended and restated our \$2.0 billion revolving credit facility as a result of changes in market conditions, which significantly reduced the cost of the facility. We also extended the term through May 2016. This facility provides us with credit capacity to be used for either cash borrowings or to support letters of credit. At December 31, 2011, we had \$150 million of outstanding borrowings and \$1,012 million of letters of credit issued and supported by the facility. The unused and available credit capacity of the facility was \$838 million as of December 31, 2011.

Letter of Credit Facilities — As of December 31, 2011, we had an aggregate committed capacity of \$505 million under letter of credit facilities with terms ending from June 2013 to June 2015. These facilities are currently being used to back letters of credit issued to support our bonding and financial assurance needs. Our letters of credit generally have terms providing for automatic renewal after one year. In the event of an unreimbursed draw on a letter of credit, the amount of the draw paid by the letter of credit provider generally converts into a term loan for the remaining term of the respective facility. Through December 31, 2011, we had not experienced any unreimbursed draws on letters of credit under these facilities. As of December 31, 2011, no borrowings were outstanding under these letter of credit facilities and we had \$3 million of unused and available credit capacity.

Canadian Credit Facility — In November 2005, Waste Management of Canada Corporation, one of our wholly-owned subsidiaries, entered into a credit facility agreement to facilitate WM's repatriation of accumulated earnings and capital from its Canadian subsidiaries. The agreement provided for an initial credit capacity of C\$340 million and matures in November 2012. At December 31, 2011, we had U.S.\$137 million of borrowings outstanding under this credit facility.

Debt Borrowings and Repayments

The significant changes in our debt balances from December 31, 2010 to December 31, 2011 are related to the following:

Revolving Credit Facility — During the third quarter of 2011, we borrowed \$100 million under our revolving credit facility in connection with our acquisition of Oakleaf, which is discussed further in Note 19. These borrowings were repaid with proceeds from our August 2011 issuance of senior notes. The \$150 million of

WASTE MANAGEMENT, INC.

NOTES TO CONSOLIDATED FINANCIAL STATEMENTS — (Continued)

borrowings outstanding as of December 31, 2011 were incurred for general corporate purposes, including additions to working capital, capital expenditures and the funding of acquisitions and investments. We borrowed another \$50 million under our revolving credit agreement in January, bringing the total outstanding as of the date of this filing to \$200 million. We currently expect to repay these borrowings during 2012 with cash flow generated by our operations. Due to the short-term maturities of these borrowings, we have reported these cash flows on a net basis in the Consolidated Statement of Cash Flows in accordance with accounting principles generally accepted in the U.S.

Canadian Credit Facility — A total of U.S.\$77 million of net advances under the facility matured during 2011 and were repaid with available cash.

Senior Notes — In February 2011, we issued \$400 million of 4.60% senior notes due March 2021. The net proceeds from the debt issuance were \$396 million. We used a portion of the proceeds to repay \$147 million of 7.65% senior notes that matured in March 2011. In August 2011, we issued \$500 million of 2.60% senior notes due September 2016. The net proceeds from the debt issuance were \$497 million. A portion of the proceeds was used to repay the \$100 million borrowing under our \$2.0 billion revolving credit facility, which is discussed above, and the remainder was incurred for general corporate purposes, including additions to working capital, capital expenditures and the funding of acquisitions and investments.

The remaining change in the carrying value of our senior notes from December 31, 2010 to December 31, 2011 is principally due to accounting for our fixed-to-floating interest rate swap agreements, which are accounted for as fair value hedges resulting in all fair value adjustments being reflected as a component of the carrying value of the underlying debt. Refer to Note 8 for additional information regarding our interest rate derivatives.

Tax-Exempt Bonds — During the year ended December 31, 2011, we issued \$100 million of tax-exempt bonds, which are used as a means of accessing low-cost financing for capital expenditures. The proceeds from these debt issuances may only be used for the specific purpose for which the money was raised, which is generally to finance expenditures for landfill construction and development. We repaid \$25 million of our tax-exempt bonds with available cash during the year ended December 31, 2011. Additional information related to the presentation of these borrowings in the Consolidated Statement of Cash Flows is discussed in Note 3.

Tax-Exempt Project Bonds — In the past, our Wheelabrator Group used tax-exempt project bonds to finance the development of waste-to-energy facilities. During the year ended December 31, 2011, we repaid \$30 million of our tax-exempt project bonds with available cash.

Capital Leases and Other — The decrease in our capital leases and other debt obligations is primarily due to the repayment of \$87 million of various borrowings upon their scheduled maturities, net of new leases and borrowings of \$48 million.

Scheduled Debt Payments — Scheduled principal payments of our debt and capital leases for the next five years are as follows: \$918 million in 2012; \$210 million in 2013; \$460 million in 2014; \$455 million in 2015; and \$696 million in 2016. Our recorded debt and capital lease obligations include non-cash adjustments associated with discounts, premiums and fair value adjustments for interest rate hedging activities, which have been excluded from these amounts because they will not result in cash payments.

Secured Debt

Our debt balances are generally unsecured, except for capital leases and the note payable associated with our investment in federal low-income housing tax credits. During 2011, we repaid \$30 million of tax-exempt project bonds that had been secured by certain of our Wheelabrator Group's assets.

WASTE MANAGEMENT, INC.

NOTES TO CONSOLIDATED FINANCIAL STATEMENTS — (Continued)

Debt Covenants

Our revolving credit facility and certain other financing agreements contain financial covenants. The most restrictive of these financial covenants are contained in our revolving credit facility. The following table summarizes the requirements of these financial covenants, as defined by the revolving credit facility:

| | |
|-----------------------------------|-------------|
| Interest coverage ratio | > 2.75 to 1 |
| Total debt to EBITDA | < 3.5 to 1 |

Our revolving credit facility and senior notes also contain certain restrictions intended to monitor our level of indebtedness, types of investments and net worth. We monitor our compliance with these restrictions, but do not believe that they significantly impact our ability to enter into investing or financing arrangements typical for our business. As of December 31, 2011 and December 31, 2010, we were in compliance with the covenants and restrictions under all of our debt agreements.

8. Derivative Instruments and Hedging Activities

The following table summarizes the fair values of derivative instruments recorded in our Consolidated Balance Sheet (in millions):

| <u>Derivatives Designated as Hedging Instruments</u> | <u>Balance Sheet Location</u> | <u>December 31,</u> | |
|--|-------------------------------|---------------------|-------------|
| | | <u>2011</u> | <u>2010</u> |
| Interest rate contracts | Current other assets | \$— | \$ 1 |
| Electricity commodity contracts | Current other assets | 5 | — |
| Interest rate contracts | Long-term other assets | <u>73</u> | <u>37</u> |
| Total derivative assets | | <u>\$78</u> | <u>\$38</u> |
| Interest rate contracts | Current accrued liabilities | \$42 | \$11 |
| Electricity commodity contracts | Current accrued liabilities | — | 1 |
| Interest rate contracts | Long-term accrued liabilities | 32 | 13 |
| Foreign exchange contracts | Long-term accrued liabilities | <u>2</u> | <u>3</u> |
| Total derivative liabilities | | <u>\$76</u> | <u>\$28</u> |

We have not offset fair value amounts recognized for our derivative instruments. For information related to the methods used to measure our derivative assets and liabilities at fair value, refer to Note 18.

WASTE MANAGEMENT, INC.

NOTES TO CONSOLIDATED FINANCIAL STATEMENTS — (Continued)

Interest Rate Derivatives

Interest Rate Swaps

We use interest rate swaps to maintain a portion of our debt obligations at variable market interest rates. As of December 31, 2011, we had approximately \$6.1 billion in fixed-rate senior notes outstanding. The interest payments on \$1 billion, or 16%, of these senior notes have been swapped to variable interest rates to protect the debt against changes in fair value due to changes in benchmark interest rates. As of December 31, 2010, we had approximately \$5.4 billion in fixed-rate senior notes outstanding, of which \$500 million, or 9%, had been swapped to variable interest rates. The significant terms of our interest rate swap agreements as of December 31, 2011 and 2010 are summarized in the table below (in millions):

| <u>As of</u> | <u>Notional Amount</u> | <u>Receive</u> | <u>Pay</u> | <u>Maturity Date</u> |
|---------------------------|------------------------|--------------------|----------------------|------------------------|
| December 31, 2011 | \$1,000 | Fixed 5.00%-7.125% | Floating 0.38%-6.11% | Through March 15, 2018 |
| December 31, 2010 | \$ 500 | Fixed 5.00%-7.65% | Floating 0.10%-4.69% | Through March 15, 2018 |

The increase in the notional amount of our interest rate swaps from December 31, 2010 to December 31, 2011 was due to the execution of \$600 million of interest rate swaps in March 2011 partially offset by the scheduled maturity of \$100 million of interest rate swaps in March 2011.

We have designated our interest rate swaps as fair value hedges of our fixed-rate senior notes. Fair value hedge accounting for interest rate swap contracts has increased the carrying value of our debt instruments by \$102 million as of December 31, 2011 and \$79 million as of December 31, 2010. The following table summarizes the fair value adjustments from interest rate swap agreements at December 31 (in millions):

| <u>Increase in Carrying Value of Debt Due to Hedge Accounting for Interest Rate Swaps</u> | <u>December 31,</u> | |
|---|---------------------|-------------|
| | <u>2011</u> | <u>2010</u> |
| Senior notes: | | |
| Active swap agreements | \$ 73 | \$38 |
| Terminated swap agreements | 29 | 41 |
| | <u>\$102</u> | <u>\$79</u> |

Gains or losses on the derivatives as well as the offsetting losses or gains on the hedged items attributable to our interest rate swaps are recognized in current earnings. We include gains and losses on our interest rate swaps as adjustments to interest expense, which is the same financial statement line item where offsetting gains and losses on the related hedged items are recorded. The following table summarizes the fair value adjustments from interest rate swaps and the underlying hedged items on our results of operations (in millions):

| <u>Years Ended December 31,</u> | <u>Statement of Operations Classification</u> | <u>Gain (Loss) on Swap</u> | <u>Gain (Loss) on Fixed-Rate Debt</u> |
|---------------------------------|---|----------------------------|---------------------------------------|
| 2011 | Interest expense | \$ 35 | \$(35) |
| 2010 | Interest expense | \$ 6 | \$(6) |
| 2009 | Interest expense | \$(60) | \$ 60 |

WASTE MANAGEMENT, INC.

NOTES TO CONSOLIDATED FINANCIAL STATEMENTS — (Continued)

We also recognize the impacts of (i) net periodic settlements of current interest on our active interest rate swaps and (ii) the amortization of previously terminated interest rate swap agreements as adjustments to interest expense. The following table summarizes the impact of periodic settlements of active swap agreements and the impact of terminated swap agreements on our results of operations (in millions):

| <u>Decrease to Interest Expense Due to Hedge Accounting for Interest Rate Swaps</u> | <u>Years Ended December 31,</u> | | |
|---|---------------------------------|-------------|-------------|
| | <u>2011</u> | <u>2010</u> | <u>2009</u> |
| Periodic settlements of active swap agreements(a) | \$23 | \$29 | \$46 |
| Terminated swap agreements | <u>12</u> | <u>18</u> | <u>19</u> |
| | <u>\$35</u> | <u>\$47</u> | <u>\$65</u> |

(a) These amounts represent the net of our periodic variable-rate interest obligations and the swap counterparties' fixed-rate interest obligations. Our variable-rate obligations are based on a spread from the three-month LIBOR. The significant decline in the benefit from active swaps when comparing 2010 with 2009 is due to a decrease in the notional amount of swaps outstanding, offset, in part, by a decline in three-month LIBOR rates.

Forward-Starting Interest Rate Swaps

In 2009, we entered into forward-starting interest rate swaps with a total notional value of \$525 million to hedge the risk of changes in semi-annual interest payments due to fluctuations in the forward ten-year LIBOR swap rate for anticipated fixed-rate debt issuances in 2011, 2012 and 2014. We designated these forward-starting interest rate swaps as cash flow hedges.

During the first quarter of 2011, \$150 million of these forward-starting interest rate swaps were terminated contemporaneously with the actual issuance of senior notes in February 2011, and we paid cash of \$9 million to settle the liability related to these swap agreements. The ineffectiveness recognized upon termination of the hedges was immaterial and the related deferred loss continues to be recorded as a component of "Accumulated other comprehensive income." The deferred loss is being amortized as an increase to interest expense over the ten-year life of the senior notes issued in February 2011 using the effective interest method. The incremental interest expense associated with these forward-starting interest rate swaps was immaterial during the year ended December 31, 2011 and is expected to be immaterial over the next twelve months.

The forward-starting interest rate swaps outstanding as of December 31, 2011 relate to anticipated debt issuances in November 2012 and March 2014. As of December 31, 2011, the fair value of these active interest rate derivatives was comprised of \$42 million of current liabilities and \$32 million of long-term liabilities compared with \$13 million of long-term liabilities as of December 31, 2010.

We recognized pre-tax and after-tax losses of \$59 million and \$37 million, respectively, to other comprehensive income for changes in the fair value of our forward-starting interest rate swaps during the year ended December 31, 2011 and \$33 million and \$20 million, respectively, during the year ended December 31, 2010. We recognized pre-tax and after-tax gains of \$9 million and \$5 million, respectively, to other comprehensive income for changes in the fair value of our forward-starting interest rate swaps during the year ended December 31, 2009. There was no significant ineffectiveness associated with these hedges during the years ended December 31, 2011, 2010 or 2009.

Treasury Rate Locks

During the third quarter of 2009, we entered into Treasury rate locks with a total notional amount of \$200 million to hedge the risk of changes in semi-annual interest payments for a portion of the senior notes that the Company planned to issue in June 2010. The Treasury rate locks were terminated in the second quarter of 2010

WASTE MANAGEMENT, INC.

NOTES TO CONSOLIDATED FINANCIAL STATEMENTS — (Continued)

contemporaneously with the actual issuance of senior notes, and we paid cash of \$7 million upon settlement. In 2009, we recognized pre-tax and after-tax gains of \$4 million and \$2 million, respectively, to other comprehensive income for changes in the fair value of these Treasury rate locks. In 2010, we recognized pre-tax and after-tax losses of \$11 million and \$7 million, respectively, to other comprehensive income for changes in the fair value of these Treasury rate locks. There was no significant ineffectiveness associated with these hedges during 2009 or 2010.

At December 31, 2011 and 2010, our “Accumulated other comprehensive income” included \$12 million and \$16 million, respectively, of deferred losses, net of taxes, associated with the Treasury rate locks mentioned above and with Treasury rate locks that had been executed in previous years in anticipation of senior note issuances. These deferred losses are reclassified as an increase to interest expense over the life of the related senior note issuances, which extend through 2032. Pre-tax amounts of \$7 million, \$8 million and \$9 million were reclassified out of accumulated other comprehensive income and into interest expense in 2011, 2010 and 2009, respectively. As of December 31, 2011, \$7 million (on a pre-tax basis) is scheduled to be reclassified as an increase to interest expense over the next twelve months.

Credit-Risk-Related Contingent Features

Certain of our interest rate derivative instruments contain provisions related to the Company’s credit rating. If the Company’s credit rating were to fall to specified levels below investment grade, the counterparties have the ability to terminate the derivative agreements, resulting in settlement of all affected transactions. As of December 31, 2011, we had not experienced any credit events that would trigger these provisions, nor did we have any derivative instruments with credit-risk-related contingent features that were in a net liability position.

Foreign Exchange Derivatives

We use foreign currency exchange rate derivatives to hedge our exposure to fluctuations in exchange rates for anticipated intercompany cash transactions between WM Holdings, and its Canadian subsidiaries.

As of December 31, 2009, the hedged cash flows included C\$370 million of principal and C\$22 million of interest scheduled to be paid in December 2010. The intercompany note and related forward contracts matured in December 2010 and we paid cash of U.S. \$37 million to settle the forward contracts.

In December 2010, we executed a new C\$370 million intercompany debt arrangement and entered into new forward contracts for the related principal and interest cash flows. The total notional value of the forward contracts was C\$401 million at December 31, 2010. Interest of C\$10 million was paid on November 30, 2011 and the related forward contract matured, resulting in a remaining notional value of C\$391 million at December 31, 2011. Scheduled interest payments as of December 31, 2011 are as follows: C\$11 million on November 30, 2012 and C\$10 million on October 31, 2013. The principal is scheduled to be repaid on October 31, 2013. We designated these forward contracts as cash flow hedges.

WASTE MANAGEMENT, INC.

NOTES TO CONSOLIDATED FINANCIAL STATEMENTS — (Continued)

Gains or losses on the underlying hedged items attributable to foreign currency exchange risk are recognized in current earnings. The gains or losses on our foreign currency forward contracts that are reclassified out of accumulated other comprehensive income are recognized as adjustments to other income and expense, which is the same financial statement line item where offsetting gains or losses on the related hedged items are recorded. The following table summarizes the pre-tax impacts of our foreign currency cash flow derivatives on our comprehensive income and results of operations (in millions):

| <u>Year Ended December 31,</u> | <u>Derivative Gain or (Loss) Recognized in OCI (Effective Portion)</u> | <u>Statement of Operations Classification</u> | <u>Derivative Gain or (Loss) Reclassified from AOCI into Income (Effective Portion)</u> |
|------------------------------------|--|---|---|
| 2011 | \$ 1 | Other income (expense) | \$ 4 |
| 2010 | \$(22) | Other income (expense) | \$(18) |
| 2009 | \$(47) | Other income (expense) | \$(47) |

Amounts reported in other comprehensive income and accumulated other comprehensive income are reported net of tax. Adjustments to other comprehensive income for changes in the fair value of our foreign currency cash flow hedges resulted in the recognition of after-tax gains of \$1 million during the year ended December 31, 2011; after-tax losses of \$14 million during the year ended December 31, 2010; and after-tax losses of \$28 million during the year ended December 31, 2009. After-tax adjustments for the reclassification of gains from accumulated other comprehensive income into income were \$2 million during the year ended December 31, 2011. After-tax adjustments for the reclassification of losses from accumulated other comprehensive income into income were \$11 million and \$28 million during the years ended December 2010 and 2009, respectively. Ineffectiveness has been included in other income and expense during each of the reported periods. There was no significant ineffectiveness associated with these hedges during the years ended December 31, 2011, 2010 or 2009.

Electricity Commodity Derivatives

As a result of the expiration of certain long-term electricity contracts at our waste-to-energy facilities, we use short-term “receive fixed, pay variable” electricity commodity swaps to mitigate the variability in our revenues and cash flows caused by fluctuations in the market prices for electricity. We hedged 672,360 megawatt hours, or approximately 26%, of our Wheelabrator Group’s full year 2010 merchant electricity sales and 1.55 million megawatt hours, or approximately 50%, of the Group’s full year 2011 merchant electricity sales. The swaps executed through December 31, 2011 are expected to hedge about 628,800 megawatt hours, or approximately 19%, of the Group’s full year 2012 merchant electricity sales.

We recognized pre-tax and after-tax gains of \$8 million and \$5 million, respectively, to other comprehensive income for changes in the fair value of our electricity commodity derivatives during the year ended December 31, 2011. We recognized pre-tax and after-tax adjustments of \$2 million and \$1 million, respectively, for the reclassification of gains from accumulated other comprehensive income into income during the year ended December 31, 2011. All financial statement impacts associated with these derivatives were immaterial for the year ended December 31, 2010. There was no significant ineffectiveness associated with these cash flow hedges during 2011 or 2010.

WASTE MANAGEMENT, INC.

NOTES TO CONSOLIDATED FINANCIAL STATEMENTS — (Continued)

9. Income Taxes

Provision for Income Taxes

Our “Provision for income taxes” consisted of the following (in millions):

| | <u>Years Ended December 31,</u> | | |
|----------------------------------|---------------------------------|--------------|--------------|
| | <u>2011</u> | <u>2010</u> | <u>2009</u> |
| Current: | | | |
| Federal | \$240 | \$354 | \$407 |
| State | 38 | 99 | 74 |
| Foreign | <u>35</u> | <u>22</u> | <u>26</u> |
| | <u>313</u> | <u>475</u> | <u>507</u> |
| Deferred: | | | |
| Federal | 162 | 85 | (45) |
| State | 36 | 64 | (35) |
| Foreign | <u>—</u> | <u>5</u> | <u>(14)</u> |
| | <u>198</u> | <u>154</u> | <u>(94)</u> |
| Provision for income taxes | <u>\$511</u> | <u>\$629</u> | <u>\$413</u> |

The U.S. federal statutory income tax rate is reconciled to the effective rate as follows:

| | <u>Years Ended December 31,</u> | | |
|---|---------------------------------|---------------|---------------|
| | <u>2011</u> | <u>2010</u> | <u>2009</u> |
| Income tax expense at U.S. federal statutory rate | 35.00% | 35.00% | 35.00% |
| State and local income taxes, net of federal income tax benefit | 3.46 | 4.50 | 3.75 |
| Miscellaneous federal tax credits | (3.29) | (1.67) | (1.15) |
| Noncontrolling interests | (1.11) | (1.05) | (1.56) |
| Taxing authority audit settlements and other tax adjustments | (0.47) | 0.54 | (2.89) |
| Nondeductible costs relating to acquired intangibles | 0.08 | 0.11 | 0.18 |
| Tax rate differential on foreign income | (0.70) | (0.39) | (0.24) |
| Cumulative effect of change in tax rates | 0.12 | 1.74 | (0.49) |
| Utilization of capital loss | — | — | (4.44) |
| Other | <u>0.52</u> | <u>(0.25)</u> | <u>(0.09)</u> |
| Provision for income taxes | <u>33.61%</u> | <u>38.53%</u> | <u>28.07%</u> |

WASTE MANAGEMENT, INC.

NOTES TO CONSOLIDATED FINANCIAL STATEMENTS — (Continued)

The comparability of our income taxes for the reported periods has been primarily affected by variations in our income before income taxes, tax audit settlements, changes in effective state and Canadian statutory tax rates, realization of state net operating loss and credit carry-forwards, utilization of a capital loss carry-back and miscellaneous federal tax credits. For financial reporting purposes, income before income taxes showing domestic and foreign sources was as follows (in millions) for the years ended December 31, 2011, 2010 and 2009:

| | <u>Years Ended December 31,</u> | | |
|----------------------------------|---------------------------------|----------------|----------------|
| | <u>2011</u> | <u>2010</u> | <u>2009</u> |
| Domestic | \$1,394 | \$1,517 | \$1,396 |
| Foreign | <u>126</u> | <u>114</u> | <u>77</u> |
| Income before income taxes | <u>\$1,520</u> | <u>\$1,631</u> | <u>\$1,473</u> |

Tax Audit Settlements — The Company and its subsidiaries file income tax returns in the United States, Canada and Puerto Rico, as well as various state and local jurisdictions. We are currently under audit by the IRS and from time to time we are audited by other taxing authorities. Our audits are in various stages of completion.

During 2011 we settled various state tax audits. The settlement of these tax audits resulted in a reduction to our “Provision for income taxes” of \$12 million, or \$0.03 per diluted share, for the year ended December 31, 2011.

During 2010, we settled the IRS audit for the 2009 tax year as well as various state tax audits. In addition, we finalized audits in Canada through 2005. The settlement of these tax audits resulted in a reduction to our “Provision for income taxes” of \$8 million, or \$0.02 per diluted share, for the year ended December 31, 2010.

During 2009, we settled the IRS audit for the 2008 tax year as well as various state tax audits. The settlement of these audits resulted in a reduction to our “Provision for income taxes” of \$11 million, or \$0.02 per diluted share, for the year ended December 31, 2009.

We are currently in the examination phase of IRS audits for the tax years 2010, 2011 and 2012 and expect these audits to be completed within the next three, 12 and 24 months, respectively. We participate in the IRS’s Compliance Assurance Program, which means we work with the IRS throughout the year in order to resolve any material issues prior to the filing of our year-end tax return. We are also currently undergoing audits by various state and local jurisdictions that date back to 2000. We have finalized audits in Canada through the 2005 tax year and are not currently under audit for any subsequent tax years in Canada. On July 28, 2011, we acquired Oakleaf, which is subject to IRS examinations for years dating back to 2008 and state income tax examinations for years dating back to 2002. Pursuant to the terms of our acquisition of Oakleaf, we are entitled to certain indemnifications for Oakleaf’s pre-acquisition tax liabilities.

Effective State Tax Rate Change — During 2011, our state deferred income taxes increased by \$3 million to reflect the impact of changes in the estimated tax rate at which existing temporary differences will be realized. During 2010, our current state tax rate increased from 6.25% to 6.75% resulting in an increase to our provision for income taxes of \$5 million. In addition, our state deferred income taxes increased \$37 million to reflect the impact of changes in the estimated tax rate at which existing temporary differences will be realized. During 2009, our current state tax rate increased from 6.0% to 6.25% and our deferred state tax rate increased from 5.5% to 5.75%, resulting in an increase to our income taxes of \$3 million and \$6 million, respectively. The increases in these rates are primarily due to changes in state law. The comparison of our effective state tax rate during the reported periods has also been affected by return-to-accrual adjustments, which reduced our “Provision for income taxes” in 2011 and 2009 and increased our “Provision for income taxes” in 2010.

WASTE MANAGEMENT, INC.

NOTES TO CONSOLIDATED FINANCIAL STATEMENTS — (Continued)

Canada Statutory Tax Rate Change — During 2009, the provincial tax rates in Ontario were reduced, which resulted in a \$13 million tax benefit as a result of the revaluation of the related deferred tax balances.

State Net Operating Loss and Credit Carry-Forwards — During 2011, 2010, and 2009, we utilized state net operating loss and credit carry-forwards resulting in a reduction to our “Provision for income taxes” for those periods of \$4 million, \$4 million and \$35 million, respectively.

Capital Loss Carry-Back — During 2009, we generated a capital loss from the liquidation of a foreign subsidiary. We determined that the capital loss could be utilized to offset capital gains from 2006 and 2007, which resulted in a reduction to our 2009 “Provision for income taxes” of \$65 million.

Investment in Refined Coal Facility — In January 2011, we acquired a noncontrolling interest in a limited liability company, which was established to invest in and manage a refined coal facility in North Dakota. The facility’s refinement processes qualify for federal tax credits that are expected to be realized through 2019 in accordance with Section 45 of the Internal Revenue Code. Our initial consideration for this investment consisted of a cash payment of \$48 million.

We account for our investment in this entity using the equity method of accounting, recognizing our share of the entity’s results and other reductions in “Equity in net losses of unconsolidated entities,” within our Condensed Consolidated Statement of Operations. During the year ended December 31, 2011, we recognized \$6 million of net losses resulting from our share of the entity’s operating losses. Our tax provision for the year ended December 31, 2011 was reduced by \$17 million primarily as a result of tax credits realized from this investment. See Note 20 for additional information related to this investment.

Investment in Federal Low-income Housing Tax Credits — In April 2010, we acquired a noncontrolling interest in a limited liability company established to invest in and manage low-income housing properties. The entity’s low-income housing investments qualify for federal tax credits that are expected to be realized through 2020 in accordance with Section 42 of the Internal Revenue Code.

We account for our investment in this entity using the equity method of accounting. We recognize our share of the entity’s results and reductions in value of our investment in “Equity in net losses of unconsolidated entities,” within our Consolidated Statement of Operations. The value of our investment decreases as the tax credits are generated and utilized. During the years ended December 31, 2011 and 2010, we recognized \$23 million and \$19 million of losses relating to our equity investment in this entity, \$8 million and \$5 million of interest expense, and a reduction in our tax provision of \$38 million (including \$26 million of tax credits) and \$26 million (including \$16 million of tax credits), respectively. See Note 20 for additional information related to this investment.

Unremitted Earnings in Foreign Subsidiaries — At December 31, 2011, remaining unremitted earnings in foreign operations were approximately \$750 million, which are considered permanently invested and, therefore, no provision for U.S. income taxes has been accrued for these unremitted earnings. Determination of the unrecognized deferred U.S. income tax liability is not practicable due to uncertainties related to the timing and source of any potential distribution of such funds, along with other important factors such as the amount of associated foreign tax credits.

WASTE MANAGEMENT, INC.

NOTES TO CONSOLIDATED FINANCIAL STATEMENTS — (Continued)

Deferred Tax Assets (Liabilities)

The components of the net deferred tax assets (liabilities) at December 31 are as follows (in millions):

| | December 31, | |
|--|--------------|-----------|
| | 2011 | 2010 |
| Deferred tax assets: | | |
| Net operating loss, capital loss and tax credit carry-forwards | \$ 231 | \$ 179 |
| Landfill and environmental remediation liabilities | 95 | 60 |
| Miscellaneous and other reserves | 283 | 202 |
| Subtotal | 609 | 441 |
| Valuation allowance | (156) | (132) |
| Deferred tax liabilities: | | |
| Property and equipment | (1,282) | (1,045) |
| Goodwill and other intangibles | (976) | (886) |
| Net deferred tax liabilities | \$(1,805) | \$(1,622) |

The valuation allowance increased by \$24 million in 2011 due to our acquisition of Oakleaf, changes in our capital loss carry-forward and changes in our state NOL and credit carry-forwards.

At December 31, 2011, we had \$120 million of federal net operating loss, or NOL, carry-forwards and \$1.4 billion of state NOL carry-forwards. The federal and state NOL carry-forwards have expiration dates through the year 2031. We also have a \$104 million capital loss carry-forward that expires in 2014. In addition, we have \$39 million of state tax credit carry-forwards at December 31, 2011.

We have established valuation allowances for uncertainties in realizing the benefit of certain tax loss and credit carry-forwards and other deferred tax assets. While we expect to realize the deferred tax assets, net of the valuation allowances, changes in estimates of future taxable income or in tax laws may alter this expectation.

Liabilities for Uncertain Tax Positions

A reconciliation of the beginning and ending amount of gross unrecognized tax benefits, including accrued interest for 2011, 2010 and 2009 is as follows (in millions):

| | 2011 | 2010 | 2009 |
|--|-------|-------|-------|
| Balance at January 1 | \$ 53 | \$ 75 | \$ 84 |
| Additions based on tax positions related to the current year | 9 | 5 | 6 |
| Additions based on tax positions of prior years | — | — | — |
| Additions due to acquisitions | 2 | — | — |
| Accrued interest | 2 | 3 | 4 |
| Reductions for tax positions of prior years | — | (1) | (1) |
| Settlements | (10) | (23) | (10) |
| Lapse of statute of limitations | (7) | (6) | (8) |
| Balance at December 31 | \$ 49 | \$ 53 | \$ 75 |

These liabilities are primarily included as a component of long-term “Other liabilities” in our Consolidated Balance Sheets because the Company generally does not anticipate that settlement of the liabilities will require payment of cash within the next twelve months. As of December 31, 2011, \$32 million of net unrecognized tax benefits, if recognized in future periods, would impact our effective tax rate.

WASTE MANAGEMENT, INC.

NOTES TO CONSOLIDATED FINANCIAL STATEMENTS — (Continued)

We recognize interest expense related to unrecognized tax benefits in tax expense. During the years ended December 31, 2011, 2010 and 2009 we recognized approximately \$2 million, \$3 million and \$4 million, respectively, of such interest expense as a component of our “Provision for income taxes.” We had approximately \$7 million and \$8 million of accrued interest in our Consolidated Balance Sheets as of December 31, 2011 and 2010, respectively. We do not have any accrued liabilities or expense for penalties related to unrecognized tax benefits for the years ended December 31, 2011, 2010 and 2009.

We anticipate that approximately \$7 million of liabilities for unrecognized tax benefits, including accrued interest, and \$2 million of related deferred tax assets may be reversed within the next 12 months. The anticipated reversals are related to state tax items, none of which are material, and are expected to result from audit settlements or the expiration of the applicable statute of limitations period.

Recent Legislation

The Tax Relief, Unemployment Insurance Reauthorization, and Job Creation Act, signed into law on December 17, 2010, included an extension of the bonus depreciation allowance through the end of 2012 and increased the amount of qualifying capital expenditures that can be depreciated immediately from 50% to 100%. The 100% depreciation deduction applies to qualifying property placed in service from September 8, 2010 through December 31, 2011. The acceleration of deductions on 2011 capital expenditures resulting from the bonus depreciation provision had no impact on our 2011 effective tax rate. However, the ability to accelerate depreciation deductions decreased our 2011 cash taxes by approximately \$190 million. Taking the accelerated tax depreciation will result in increased cash taxes in future periods when the deductions for these capital expenditures would have otherwise been taken.

10. Employee Benefit Plans

Defined Contribution Plans — Our Waste Management retirement savings plans are 401(k) plans that cover employees, except those working subject to collective bargaining agreements that do not allow for coverage under such plans. Employees are generally eligible to participate in the plans following a 90-day waiting period after hire and may contribute as much as 25% of their annual compensation, subject to annual contribution limitations established by the IRS. Under our largest retirement savings plan, we match, in cash, 100% of employee contributions on the first 3% of their eligible compensation and match 50% of employee contributions on the next 3% of their eligible compensation, resulting in a maximum match of 4.5%. Both employee and Company contributions vest immediately. Charges to “Operating” and “Selling, general and administrative” expenses for our defined contribution plans were \$61 million in 2011, \$55 million in 2010 and \$50 million in 2009.

Defined Benefit Plans (other than multiemployer defined benefit plans discussed below) — Certain of the Company’s subsidiaries sponsor pension plans that cover employees not otherwise covered by the Waste Management retirement savings plans. These employees are members of collective bargaining units. In addition, Wheelabrator Technologies Inc., a wholly-owned subsidiary, sponsors a pension plan for its former executives and former Board members. As of December 31, 2011, the combined benefit obligation of these pension plans was \$92 million, and the plans had \$62 million of plan assets, resulting in an unfunded benefit obligation for these plans of \$30 million.

In addition, WM Holdings and certain of its subsidiaries provided post-retirement health care and other benefits to eligible employees. In conjunction with our acquisition of WM Holdings in July 1998, we limited participation in these plans to participating retired employees as of December 31, 1998. The unfunded benefit obligation for these plans was \$43 million at December 31, 2011.

Our accrued benefit liabilities for our defined benefit pension and other post-retirement plans are \$73 million as of December 31, 2011 and are included as components of “Accrued liabilities” and long-term “Other liabilities” in our Consolidated Balance Sheet.

WASTE MANAGEMENT, INC.

NOTES TO CONSOLIDATED FINANCIAL STATEMENTS — (Continued)

Multiemployer Defined Benefit Plans — We are a participating employer in a number of trustee-managed multiemployer, defined benefit pension plans for employees who participate in collective bargaining agreements. The risks of participating in these multiemployer plans are different from single-employer plans in that (i) assets contributed to the multiemployer plan by one employer may be used to provide benefits to employees of other participating employers; (ii) if a participating employer stops contributing to the plan, the unfunded obligations of the plan may be required to be assumed by the remaining participating employers and (iii) if we choose to stop participating in any of our multiemployer plans, we may be required to pay those plans a withdrawal amount based on the underfunded status of the plan. The following table outlines our participation in multiemployer plans considered to be individually significant (dollar amounts in millions):

| Pension Fund | EIN/Pension Plan Number | Pension Protection Act Reported Status(a) | | FIP/RP Status(b)(c) | Contributions(d) | | | Expiration Date of Collective Bargaining Agreement |
|---|--------------------------------------|---|----------------------------------|---------------------|------------------|------|------|--|
| | | 2011 | 2010 | | 2011 | 2010 | 2009 | |
| Automotive Industries Pension Plan | EIN: 94-1133245; Plan Number: 001 | Critical | Critical | Implemented | \$ 1 | \$ 1 | \$ 1 | Various dates through 8/31/2014 |
| Central States, Southeast and Southwest Areas Pension Plan | EIN: 36-6044243; Plan Number: 001 | Critical | Critical | Implemented | — | — | 1 | (e) |
| Distributors Association Warehousemens Pension Trust | EIN: 94-0294755 Plan Number: 002 | Critical as of 5/31/2010 | Critical as of 5/31/2009 | Implemented | 1 | 1 | 1 | 5/31/2010; negotiations ongoing |
| Local 731 Private Scavengers and Garage Attendants Pension Trust Fund | EIN: 36-6513567; Plan Number: 001 | Endangered as of 9/30/2010 | Endangered as of 9/30/2009 | Implemented | 4 | 4 | 3 | 9/30/2013 and 9/30/2014 |
| New England Teamsters and Trucking Industry Pension Fund | EIN: 04-6372430; Plan Number: 001 | Critical as of 9/30/2010 | Critical as of 9/30/2009 | Implemented | — | — | — | 2/28/2013 |
| Suburban Teamsters of Northern Illinois Pension Plan | EIN: 36-6155778; Plan Number: 001 | Critical | Critical | Implemented | 2 | 2 | 2 | Various dates through 3/31/2015 |
| Teamsters Employers Local 945 Pension Fund | EIN: 22-6196388; Plan Number: 001 | Critical | Critical | Implemented | — | — | — | Various dates through 12/31/2014 |
| Western Conference of Teamsters Pension Plan | EIN: 91-6145047; Plan Number: 001 | Not Endangered or Critical | Not Endangered or Critical | Not applicable | 20 | 20 | 18 | Various dates through 6/30/2017 |
| Western Pennsylvania Teamsters and Employers Pension Plan | EIN: 25-6029946; Plan Number: 001 | Critical | Critical | Implemented | 1 | 1 | 1 | 12/31/2011; negotiations ongoing |

- (a) Unless otherwise noted in the table, the most recent Pension Protection Act zone status available in 2011 and 2010 is for the plan's year-end at December 31, 2010 and 2009, respectively. The zone status is based on information that we received from the plan and is certified by the plan's actuary. As defined in the Pension Protection Act of 2006, among other factors, plans reported as critical are generally less than 65% funded and plans reported as endangered are generally either less than 80% funded or meet certain accumulated funding deficiency criteria.
- (b) The "FIP/RP Status" column indicates plans for which a Funding Improvement Plan ("FIP") or a Rehabilitation Plan ("RP") is either pending or has been implemented.

WASTE MANAGEMENT, INC.

NOTES TO CONSOLIDATED FINANCIAL STATEMENTS — (Continued)

- (c) A multiemployer defined benefit pension plan that has been certified as endangered, seriously endangered or critical may begin to levy a statutory surcharge on contribution rates. Once authorized, the surcharge is at the rate of 5% for the first 12 months and 10% for any periods thereafter. Contributing employers, however, may eliminate the surcharge by entering into a collective bargaining agreement that meets the requirements of the applicable FIP or RP.
- (d) The Company was listed in the Form 5500 as providing more than 5% of the total contributions for each of the following plans and plan years:

| | Year Contributions to Plan Exceeded 5% of Total Contributions (as of Plan's Year End) |
|--|--|
| Distributors Association Warehousemens Pension Trust | 5/31/2010 |
| Local 731 Private Scavengers and Garage Attendants Pension Trust Fund | 9/30/2010 |
| Suburban Teamsters of Northern Illinois Pension Plan | 12/31/2010 and 12/31/2009 |

At the date the financial statements were issued, Forms 5500 were not available for the plan years ended in 2011. For the plan years ended in 2009, Forms 5500 were not available for the following plans: Distributors Association Warehousemens Pension Trust, Local 731 Private Scavengers and Garage Attendants Pension Trust Fund and New England Teamsters and Trucking Industry Pension Fund.

- (e) While the subject of pending litigation, the Company has no collective bargaining agreements remaining that require contributions to this fund.

The following table summarizes all contributions made to multiemployer defined benefit pension plans, which were charged to operations for our subsidiaries' ongoing participation in these defined benefit plans (in millions):

| | Years Ended December 31, | | |
|--|-------------------------------------|-------------|-------------|
| | 2011 | 2010 | 2009 |
| Contributions to individually significant multiemployer defined benefit pension plans | \$29 | \$29 | \$27 |
| Contributions to all other multiemployer defined benefit pension plans | 7 | 7 | 7 |
| Total contributions to multiemployer defined benefit pension plans | \$36 | \$36 | \$34 |

Our portion of the projected benefit obligation, plan assets and unfunded liability of the multiemployer pension plans is not material to our financial position. However, the failure of participating employers to remain solvent could affect our portion of the plans' unfunded liability. Specific benefit levels provided by union pension plans are not negotiated with or known by the employer contributors.

In connection with our ongoing renegotiations of various collective bargaining agreements, we may discuss and negotiate for the complete or partial withdrawal from one or more of these pension plans. If we elect to withdraw from these plans, we may incur expenses associated with our obligations for unfunded vested benefits at the time of the withdrawal. As discussed in Note 11, in 2010 and 2009, we recognized aggregate charges of \$26 million and \$9 million, respectively, to "Operating" expenses for the withdrawal of certain bargaining units from multiemployer pension plans.

11. Commitments and Contingencies

Financial Instruments — We have obtained letters of credit, performance bonds and insurance policies and have established trust funds and issued financial guarantees to support tax-exempt bonds, contracts, performance of landfill final capping, closure and post-closure requirements, environmental remediation, and other obligations. Letters of credit generally are supported by our revolving credit facility and other credit facilities

WASTE MANAGEMENT, INC.

NOTES TO CONSOLIDATED FINANCIAL STATEMENTS — (Continued)

established for that purpose. These facilities are discussed further in Note 7. We obtain surety bonds and insurance policies from an entity in which we have a noncontrolling financial interest. We also obtain insurance from a wholly-owned insurance company, the sole business of which is to issue policies for us. In those instances where our use of financial assurance from entities we own or have financial interests in is not allowed, we have available alternative financial assurance mechanisms.

Management does not expect that any claims against or draws on these instruments would have a material adverse effect on our consolidated financial statements. We have not experienced any unmanageable difficulty in obtaining the required financial assurance instruments for our current operations. In an ongoing effort to mitigate risks of future cost increases and reductions in available capacity, we continue to evaluate various options to access cost-effective sources of financial assurance.

Insurance — We carry insurance coverage for protection of our assets and operations from certain risks including automobile liability, general liability, real and personal property, workers' compensation, directors' and officers' liability, pollution legal liability and other coverages we believe are customary to the industry. Our exposure to loss for insurance claims is generally limited to the per incident deductible under the related insurance policy. Our exposure, however, could increase if our insurers are unable to meet their commitments on a timely basis.

We have retained a significant portion of the risks related to our automobile, general liability and workers' compensation claims programs. For our self-insured retentions, the exposure for unpaid claims and associated expenses, including incurred but not reported losses, is based on an actuarial valuation and internal estimates. The accruals for these liabilities could be revised if future occurrences or loss development significantly differ from our assumptions used. As of December 31, 2011, our general liability insurance program carried self-insurance exposures of up to \$2.5 million per incident and our workers' compensation insurance program carried self-insurance exposures of up to \$5 million per incident. As of December 31, 2011, our auto liability insurance program included a per-incident base deductible of \$5 million, subject to additional deductibles of \$4.8 million in the \$5 million to \$10 million layer. Self-insurance claims reserves acquired as part of our acquisition of WM Holdings in July 1998 were discounted at 2.0% at December 31, 2011, 3.50% at December 31, 2010 and 3.75% at December 31, 2009. The changes to our net insurance liabilities for the three years ended December 31, 2011 are summarized below (in millions):

| | <u>Gross Claims Liability</u> | <u>Receivables Associated with Insured Claims(a)</u> | <u>Net Claims Liability</u> |
|---|-------------------------------|--|-----------------------------|
| Balance, December 31, 2008 | \$ 531 | \$(191) | \$ 340 |
| Self-insurance expense (benefit) | 184 | (32) | 152 |
| Cash (paid) received | <u>(174)</u> | <u>29</u> | <u>(145)</u> |
| Balance, December 31, 2009 | 541 | (194) | 347 |
| Self-insurance expense (benefit) | 179 | (38) | 141 |
| Cash (paid) received | <u>(197)</u> | <u>62</u> | <u>(135)</u> |
| Balance, December 31, 2010 | 523 | (170) | 353 |
| Self-insurance expense (benefit) | 176 | (14) | 162 |
| Cash (paid) received | <u>(188)</u> | <u>23</u> | <u>(165)</u> |
| Balance, December 31, 2011(b) | <u>\$ 511</u> | <u>\$(161)</u> | <u>\$ 350</u> |
| Current portion at December 31, 2011 | \$ 135 | \$ (40) | \$ 95 |
| Long-term portion at December 31, 2011 | \$ 376 | \$(121) | \$ 255 |

WASTE MANAGEMENT, INC.

NOTES TO CONSOLIDATED FINANCIAL STATEMENTS — (Continued)

-
- (a) Amounts reported as receivables associated with insured claims are related to both paid and unpaid claims liabilities.
- (b) We currently expect substantially all of our recorded obligations to be settled in cash in the next five years.

The Directors' and Officers' Liability Insurance policy we choose to maintain covers only individual executive liability, often referred to as "Broad Form Side A," and does not provide corporate reimbursement coverage, often referred to as "Side B." The Side A policy covers directors and officers directly for loss, including defense costs, when corporate indemnification is unavailable. Side A-only coverage cannot be exhausted by payments to the Company, as the Company is not insured for any money it advances for defense costs or pays as indemnity to the insured directors and officers.

We do not expect the impact of any known casualty, property, environmental or other contingency to have a material impact on our financial condition, results of operations or cash flows.

Operating Leases — Rental expense for leased properties was \$138 million during 2011, \$121 million during 2010 and \$114 million during 2009. Minimum contractual payments due for our operating lease obligations are \$91 million in 2012, \$77 million in 2013, \$68 million in 2014, \$56 million in 2015 and \$45 million in 2016.

Our minimum contractual payments for lease agreements during future periods is significantly less than current year rent expense due to short-term leases and because our significant lease agreements at landfills have variable terms based either on a percentage of revenue or a rate per ton of waste received.

Other Commitments

- *Fuel Supply* — We have purchase agreements expiring at various dates through 2025 that require us to purchase minimum amounts of wood waste, anthracite coal waste (culm) and conventional fuels at our independent power production plants. These fuel supplies are used to produce steam that is sold to industrial and commercial users and electricity that is sold to electric utilities, which is generally subject to the terms and conditions of long-term contracts. Our purchase agreements have been established based on the plants' anticipated fuel supply needs to meet the demands of our customers under these long-term electricity sale contracts. Under our fuel supply take-or-pay contracts, we are generally obligated to pay for a minimum amount of waste or conventional fuel at a stated rate even if such quantities are not required in our operations.
- *Disposal* — We have several agreements expiring at various dates through 2052 that require us to dispose of a minimum number of tons at third-party disposal facilities. Under these put-or-pay agreements, we are required to pay for the agreed upon minimum volumes regardless of the actual number of tons placed at the facilities. We generally fulfill our minimum contractual obligations by disposing of volumes collected in the ordinary course of business at these disposal facilities.
- *Waste Paper* — We are party to waste paper purchase agreements expiring at various date through 2016 that require us to purchase a minimum number of tons of waste paper. The cost per ton we pay is based on market prices.
- *Royalties* — We have various arrangements that require us to make royalty payments to third parties including prior land owners, lessors or host communities where our operations are located. Our obligations generally are based on per ton rates for waste actually received at our transfer stations, landfills or waste-to-energy facilities. Royalty agreements that are non-cancelable and require fixed or minimum payments are recorded as obligations in our Consolidated Balance Sheet.
- *Credit Commitment* — In 2011, we made a noncontrolling equity investment in an entity focused on the conversion of municipal solid waste into advanced bio-fuels. In connection with this investment, we agreed to provide the entity with a secured loan facility whereby we would fund up to \$70 million to

WASTE MANAGEMENT, INC.

NOTES TO CONSOLIDATED FINANCIAL STATEMENTS — (Continued)

support the construction of the entity's first bio-fuel facility. Our obligation to fund this secured loan agreement is contingent upon the satisfaction of certain conditions by the borrower. The borrower has until November 2014 to draw on the facility and must repay the loan over a term not to exceed 12 years from the plant's commencement of commercial operations.

Our unconditional obligations are established in the ordinary course of our business and are structured in a manner that provides us with access to important resources at competitive, market-driven rates. Our actual future minimum obligations under these outstanding agreements are generally quantity driven and, as a result, our associated financial obligations are not fixed as of December 31, 2011. For contracts that require us to purchase minimum quantities of goods or services, we have estimated our future minimum obligations based on the current market values of the underlying products or services. As of December 31, 2011, our estimated minimum obligations for the above-described purchase obligations, which are not recognized in our Consolidated Balance Sheet in accordance with accounting principles generally accepted in the U.S., were \$148 million in 2012, \$143 million in 2013, \$47 million in 2014, \$36 million in 2015 and \$29 million in 2016. We currently expect the products and services provided by these agreements to continue to meet the needs of our ongoing operations. Therefore, we do not expect these established arrangements to materially impact our future financial position, results of operations or cash flows.

Guarantees — We have entered into the following guarantee agreements associated with our operations:

- As of December 31, 2011, WM Holdings has fully and unconditionally guaranteed all of WM's senior indebtedness, including its senior notes, revolving credit agreement and certain letter of credit facilities, which mature through 2039. WM has fully and unconditionally guaranteed the senior indebtedness of WM Holdings, which matures in 2026. Performance under these guarantee agreements would be required if either party defaulted on their respective obligations. No additional liabilities have been recorded for these guarantees because the underlying obligations are reflected in our Consolidated Balance Sheets. See Note 23 for further information.
- WM and WM Holdings have guaranteed the tax-exempt bonds and other debt obligations of their subsidiaries. If a subsidiary fails to meet its obligations associated with its debt agreements as they come due, WM or WM Holdings will be required to perform under the related guarantee agreement. No additional liabilities have been recorded for these guarantees because the underlying obligations are reflected in our Consolidated Balance Sheets. See Note 7 for information related to the balances and maturities of our tax-exempt bonds.
- We have guaranteed certain financial obligations of unconsolidated entities. The related obligations, which mature through 2020, are not recorded on our Consolidated Balance Sheets. As of December 31, 2011, our maximum future payments associated with these guarantees are approximately \$20 million. We do not believe that it is likely that we will be required to perform under these guarantees.
- Certain of our subsidiaries have guaranteed the market or contractually-determined value of certain homeowners' properties that are adjacent to certain of our landfills. These guarantee agreements extend over the life of the respective landfill. Under these agreements, we would be responsible for the difference, if any, between the sale value and the guaranteed market or contractually-determined value of the homeowners' properties. As of December 31, 2011, we have agreements guaranteeing certain market value losses for approximately 900 homeowners' properties adjacent to or near 21 of our landfills. We do not believe that these contingent obligations will have a material effect on our financial position, results of operations or cash flows.
- We have indemnified the purchasers of businesses or divested assets for the occurrence of specified events under certain of our divestiture agreements. Other than certain identified items that are currently recorded as obligations, we do not believe that it is possible to determine the contingent obligations associated with these indemnities. Additionally, under certain of our acquisition agreements, we have provided for additional consideration to be paid to the sellers if established financial targets are achieved

WASTE MANAGEMENT, INC.

NOTES TO CONSOLIDATED FINANCIAL STATEMENTS — (Continued)

post-closing. For acquisitions completed subsequent to January 1, 2009, we have recognized liabilities for these contingent obligations based on an estimate of the fair value of these contingencies at the time of acquisition. For acquisitions completed before January 1, 2009, the costs associated with any additional consideration requirements are accounted for as incurred. Contingent obligations related to indemnifications arising from our divestitures and contingent consideration provided for by our acquisitions are not expected to be material to our financial position, results of operations or cash flows.

- WM and WM Holdings guarantee the service, lease, financial and general operating obligations of certain of their subsidiaries. If such a subsidiary fails to meet its contractual obligations as they come due, the guarantor has an unconditional obligation to perform on its behalf. No additional liability has been recorded for service, financial or general operating guarantees because the subsidiaries' obligations are properly accounted for as costs of operations as services are provided or general operating obligations as incurred. No additional liability has been recorded for the lease guarantees because the subsidiaries' obligations are properly accounted for as operating or capital leases, as appropriate.

We currently do not believe it is reasonably likely that we would be called upon to perform under these guarantees and do not believe that any of the obligations would have a material effect on our financial position, results of operations or cash flows.

Environmental Matters — A significant portion of our operating costs and capital expenditures could be characterized as costs of environmental protection as we are subject to an array of laws and regulations relating to the protection of the environment. Under current laws and regulations, we may have liabilities for environmental damage caused by our operations, or for damage caused by conditions that existed before we acquired a site. In addition to remediation activity required by state or local authorities, such liabilities include potentially responsible party, or PRP, investigations. The costs associated with these liabilities can include settlements, certain legal and consultant fees, as well as incremental internal and external costs directly associated with site investigation and clean-up.

As of December 31, 2011, we had been notified that we are a PRP in connection with 80 locations listed on the EPA's Superfund National Priorities List, or NPL. Of the 80 sites at which claims have been made against us, 17 are sites we own. Each of the NPL sites we own was initially developed by others as a landfill disposal facility. At each of these facilities, we are working in conjunction with the government to characterize or remediate identified site problems, and we have either agreed with other legally liable parties on an arrangement for sharing the costs of remediation or are working toward a cost-sharing agreement. We generally expect to receive any amounts due from other participating parties at or near the time that we make the remedial expenditures. The other 63 NPL sites, which we do not own, are at various procedural stages under the Comprehensive Environmental Response, Compensation and Liability Act of 1980, as amended, known as CERCLA or Superfund.

The majority of these proceedings involving NPL sites that we do not own are based on allegations that certain of our subsidiaries (or their predecessors) transported hazardous substances to the sites, often prior to our acquisition of these subsidiaries. CERCLA generally provides for liability for those parties owning, operating, transporting to or disposing at the sites. Proceedings arising under Superfund typically involve numerous waste generators and other waste transportation and disposal companies and seek to allocate or recover costs associated with site investigation and remediation, which costs could be substantial and could have a material adverse effect on our consolidated financial statements. At some of the sites at which we have been identified as a PRP, our liability is well defined as a consequence of a governmental decision and an agreement among liable parties as to the share each will pay for implementing that remedy. At other sites, where no remedy has been selected or the liable parties have been unable to agree on an appropriate allocation, our future costs are uncertain.

Litigation — In April 2002, certain former participants in the ERISA plans of WM Holdings filed a lawsuit in the U.S. District Court for the District of Columbia in a case entitled *William S. Harris, et al. v. James E. Koenig, et al.* The lawsuit attempts to increase the recovery of a class of ERISA plan participants on behalf of the

WASTE MANAGEMENT, INC.

NOTES TO CONSOLIDATED FINANCIAL STATEMENTS — (Continued)

plan based on allegations related to both the events alleged in, and the settlements relating to, the securities class action against WM Holdings that was settled in 1998, the litigation against WM in Texas that was settled in 2002, as well as the decision to offer WM common stock as an investment option within the plan beginning in 1990, despite alleged knowledge by at least two members of the investment committee of financial misstatement by WM during the relevant time period.

During the second quarter of 2010, the Court dismissed certain claims against individual defendants, including all claims against each of the current members of our Board of Directors. Previously, plaintiffs dismissed all claims related to the settlement of the securities class action against WM that was settled in 2002, and the court certified a limited class of participants who may bring claims on behalf of the plan, but not individually. During the third quarter of 2011, the Court ruled in favor of WM and two former employees dismissing all claims brought by the plaintiffs related to the decision to offer WM stock as an investment option within the plan. The Court still has under consideration additional motions that, if granted, would resolve the few remaining claims against WM and its Committees. The outcome of this lawsuit cannot be predicted with certainty. The defendants intend to defend themselves vigorously in this litigation.

In July 2008, subsidiaries of WM were named as defendants in purported class actions in the Circuit Court of Bullock County, Alabama, which was subsequently removed to the United States District Court for the Northern District of Alabama. This suit pertained to our fuel and environmental charge in our customer service agreements and generally alleged that such charges were not properly disclosed, were unfair and were contrary to the contracts. We filed a motion to dismiss that was partially granted during the third quarter of 2010, resulting in dismissal of the plaintiffs' national class action claims. During the third quarter of 2011, the plaintiffs filed and the Court granted a motion to dismiss the litigation without prejudice.

In October 2011 and January 2012, we were named as a defendant in a purported class action in the Circuit Court of Sarasota County, Florida and the Circuit Court of Lawrence County Alabama, respectively. These suits were filed by the same law firm that brought the Alabama litigation discussed in the prior paragraph, and these cases also primarily pertain to our fuel and environmental charges in our customer service agreements, generally alleging that such charges were not properly disclosed, were unfair and were contrary to the contracts. We will vigorously defend this matter. Given the inherent uncertainties of litigation, the ultimate outcome of these cases cannot be predicted at this time, nor can possible damages, if any, be reasonably estimated.

We often enter into contractual arrangements with landowners imposing obligations on us to meet certain regulatory or contractual conditions upon site closure or upon termination of the agreements. Compliance with these arrangements is inherently subject to subjective determinations and may result in disputes, including litigation. In May 2008, Mnoian Management, Inc. filed suit in Los Angeles County Superior Court seeking remediation and increased compaction of a site we had previously leased for landfill purposes. The parties have completed a binding arbitration, and all principal matters have been resolved.

From time to time, we also are named as defendants in personal injury and property damage lawsuits, including purported class actions, on the basis of having owned, operated or transported waste to a disposal facility that is alleged to have contaminated the environment or, in certain cases, on the basis of having conducted environmental remediation activities at sites. Some of the lawsuits may seek to have us pay the costs of monitoring of allegedly affected sites and health care examinations of allegedly affected persons for a substantial period of time even where no actual damage is proven. While we believe we have meritorious defenses to these lawsuits, the ultimate resolution is often substantially uncertain due to the difficulty of determining the cause, extent and impact of alleged contamination (which may have occurred over a long period of time), the potential for successive groups of complainants to emerge, the diversity of the individual plaintiffs' circumstances, and the potential contribution or indemnification obligations of co-defendants or other third parties, among other factors.

WASTE MANAGEMENT, INC.

NOTES TO CONSOLIDATED FINANCIAL STATEMENTS — (Continued)

As a large company with operations across the United States and Canada, we are subject to various proceedings, lawsuits, disputes and claims arising in the ordinary course of our business. Many of these actions raise complex factual and legal issues and are subject to uncertainties. Actions filed against us include commercial, customer, and employment-related claims, including purported class action lawsuits related to our customer service agreements and purported class actions involving federal and state wage and hour and other laws. The plaintiffs in some actions seek unspecified damages or injunctive relief, or both. These actions are in various procedural stages, and some are covered in part by insurance. We currently do not believe that any such actions will ultimately have a material adverse impact on our consolidated financial statements.

WM's charter and bylaws provide that WM shall indemnify against all liabilities and expenses, and upon request shall advance expenses to, any person who is subject to a pending or threatened proceeding because such person is a director or officer of the Company. Such indemnification is required to the maximum extent permitted under Delaware law. Accordingly, the director or officer must reimburse the Company for any fees advanced if it is later determined that the director or officer was not entitled to have such fees advanced under Delaware law. Additionally, WM has entered into separate indemnification agreements with each of the members of its Board of Directors, and the employment agreements between WM and its Chief Executive Officer, principal financial officer and other executive and senior vice presidents contain a direct contractual obligation of the Company to provide indemnification to the executive. The Company may incur substantial expenses in connection with the fulfillment of its advancement of costs and indemnification obligations in connection with current actions involving former officers of the Company or its subsidiaries or other actions or proceedings that may be brought against its former or current officers, directors and employees.

Item 103 of the SEC's Regulation S-K requires disclosure of certain environmental matters when a governmental authority is a party to the proceedings, or such proceedings are known to be contemplated, unless we reasonably believe that the matter will result in no monetary sanctions, or in monetary sanctions, exclusive of interest and costs, of less than \$100,000. The following matters are disclosed in accordance with that requirement:

On April 4, 2006, the EPA issued a Notice of Violation ("NOV") to Waste Management of Hawaii, Inc., an indirect wholly-owned subsidiary of WM, and to the City and County of Honolulu for alleged violations of the federal Clean Air Act, based on alleged failure to submit certain reports and design plans required by the EPA, and the failure to begin and timely complete the installation of a gas collection and control system ("GCCS") for the Waimanalo Gulch Sanitary Landfill on Oahu. The EPA has also indicated that it will seek penalties and injunctive relief as part of the NOV enforcement for elevated landfill temperatures that were recorded after installation of the GCCS. The parties have been in confidential settlement negotiations. Pursuant to an indemnity agreement, any penalty assessed will be paid by the Company, and not by the City and County of Honolulu.

On November 16, 2011, the Regional Water Quality Control Board for the San Francisco Bay Region issued an Administrative Civil Liability ("ACL") Complaint to Guadalupe Rubbish Disposal Company, Inc. ("GRDC"), an indirect wholly-owned subsidiary of WM. The ACL Complaint seeks penalties for alleged violations of California's water pollution statutes and GRDC's landfill permit relating to handling of landfill gas condensate from an on-site landfill gas-to-energy facility owned and operated by a third party. GRDC has appealed the ACL Complaint.

On December 22, 2011, the Harris County Attorney in Houston, Texas filed suit against McGinnes Industrial Maintenance Corporation ("MIMC"), WM and Waste Management of Texas, Inc., et al, seeking civil penalties and attorneys' fees for alleged violations of the Texas Water Code and the Texas Health and Safety Code. The County's Original Petition pending in the District Court of Harris County, Texas alleges the mismanagement of certain waste pits that were operated from 1965 to 1966 by MIMC. In 1998, a predecessor of WM acquired the stock of the parent entity of MIMC.

WASTE MANAGEMENT, INC.

NOTES TO CONSOLIDATED FINANCIAL STATEMENTS — (Continued)

On January 13, 2012, the Pennsylvania Department of Environmental Protection (“Department”) informed Phoenix Resources, Inc. (“Phoenix”) landfill that it intended to seek civil penalties for alleged violations of Pennsylvania solid waste regulations during the third quarter of 2011 resulting from the acceptance of certain loads of industrial waste prior to the Department’s written approval. Phoenix is an indirect wholly-owned subsidiary of WM.

Additionally, the United States Attorney’s Office for the District of Hawaii has commenced an investigation into allegations of violations of the federal Clean Water Act involving discharge of stormwater at the Waimanalo Gulch Sanitary Landfill, located on Oahu, Hawaii in connection with three major storm events in December 2010 and January 2011. No formal enforcement action has been brought against the Company, although we could potentially be subject to sanctions, including requirements to pay monetary penalties, in connection with a future proceeding that may arise from the investigation. We are cooperating with the U.S. Attorney’s Office.

Multiemployer Defined Benefit Pension Plans — About 20% of our workforce is covered by collective bargaining agreements with various union locals across the United States and Canada. As a result of some of these agreements, certain of our subsidiaries are participating employers in a number of trustee-managed multiemployer, defined benefit pension plans for the affected employees. Refer to Note 10 for additional information about our participation in multiemployer, defined benefit pension plans considered individually significant. In connection with our ongoing renegotiation of various collective bargaining agreements, we may discuss and negotiate for the complete or partial withdrawal from one or more of these pension plans. A complete or partial withdrawal from a multiemployer pension plan may also occur if employees covered by a collective bargaining agreement vote to decertify a union from continuing to represent them.

One of the most significant multiemployer pension plans in which we have participated is the Central States, Southeast and Southwest Areas Pension Plan (“Central States Pension Plan”), which has reported that it adopted a rehabilitation plan as a result of its actuarial certification for the plan year beginning January 1, 2008. The Central States Pension Plan is in “critical status,” as defined by the Pension Protection Act of 2006. We recognized charges to “Operating” expenses of \$26 million in 2010 and \$9 million in 2009 associated with the withdrawal of certain bargaining units from underfunded multiemployer pension plans. Our partial withdrawal from the Central States Pension Plan accounted for all of our 2010 charges. In October 2011, our last remaining group of employees that were active participants in the Central States Pension Plan voted to decertify the union that represented them, ceasing any contribution obligation and withdrawing them from the Central States Pension Plan.

We are still negotiating and litigating final resolutions of our withdrawal liability for previous withdrawals and our recent final withdrawal mentioned above, which could be materially higher than the charges we have recognized. We do not believe that our withdrawals from the multiemployer plans, individually or in the aggregate, will have a material adverse effect on our financial condition or liquidity. However, depending on the number of employees withdrawn in any future period and the financial condition of the multiemployer plans at the time of withdrawal, such withdrawals could materially affect our results of operations in the period of the withdrawal.

Tax Matters — We are currently in the examination phase of IRS audits for the tax years 2010, 2011 and 2012 and expect these audits to be completed within the next three, 12 and 24 months, respectively. We participate in the IRS’s Compliance Assurance Program, which means we work with the IRS throughout the year in order to resolve any material issues prior to the filing of our year-end tax return. We are also currently undergoing audits by various state and local jurisdictions that date back to 2000. We have finalized audits in Canada through the 2005 tax year and are not currently under audit for any subsequent tax years in Canada. On July 28, 2011, we acquired Oakleaf, which is subject to IRS examinations for years dating back to 2008 and state income tax examinations for years dating back to 2002. Pursuant to the terms of our acquisition of Oakleaf, we are entitled to indemnification for Oakleaf’s pre-acquisition tax liabilities. We maintain a liability for uncertain tax positions, the balance of which management believes is adequate. Results of audit assessments by taxing authorities are not currently expected to have a material adverse impact on our results of operations or cash flows.

WASTE MANAGEMENT, INC.

NOTES TO CONSOLIDATED FINANCIAL STATEMENTS — (Continued)

12. Restructuring

2011 Restructuring — Beginning in July 2011, we took steps to streamline our organization as part of our cost savings programs. This reorganization eliminated over 700 employee positions throughout the Company, including approximately 300 open positions. Additionally, subsequent to our acquisition of Oakleaf, we incurred charges in connection with restructuring that organization. During the year ended December 31, 2011, we recognized a total of \$19 million of pre-tax restructuring charges, of which \$18 million were related to employee severance and benefit costs associated with this reorganization. The remaining charges were primarily related to operating lease obligations for property that will no longer be utilized. The following table summarizes the employee severance and benefit costs and other charges recognized for this restructuring by each of our current reportable segments and our Corporate and Other organization for the year ended December 31, 2011 (in millions):

| | |
|---------------------------|-------------|
| Eastern | \$ 2 |
| Midwest | 3 |
| Southern | 2 |
| Western | 3 |
| Wheelabrator | 1 |
| Corporate and Other | <u>8</u> |
| Total | <u>\$19</u> |

Through December 31, 2011, we have paid approximately \$10 million of the employee severance and benefit costs incurred as a result of 2011 restructuring activities.

2009 Restructuring — In January 2009, we streamlined our organization by (i) consolidating many of our Market Areas; (ii) integrating the management of our recycling operations with our other solid waste business; and (iii) realigning our Corporate organization with this new structure in order to provide support functions more efficiently.

Our principal operations are managed through our Groups, which are discussed in Note 21. Each of our four geographic Groups had been further divided into 45 Market Areas. As a result of our restructuring, the Market Areas were consolidated into 25 Areas. We found that our larger Market Areas generally were able to achieve efficiencies through economies of scale that were not present in our smaller Market Areas, and this reorganization has allowed us to lower costs and to continue to standardize processes and improve productivity. In addition, during the first quarter of 2009, responsibility for the oversight of day-to-day recycling operations at our material recovery facilities and secondary processing facilities was transferred from our Waste Management Recycle America, or WMRA, organization to our four geographic Groups. By integrating the management of our recycling facilities' operations with our other solid waste business, we are able to more efficiently provide comprehensive environmental solutions to our customers. In addition, as a result of this realignment, we have significantly reduced the overhead costs associated with managing this portion of our business and have increased the geographic Groups' focus on maximizing the profitability and return on invested capital of our business on an integrated basis.

WASTE MANAGEMENT, INC.

NOTES TO CONSOLIDATED FINANCIAL STATEMENTS — (Continued)

This reorganization eliminated over 1,500 employee positions throughout the Company. During 2009, we recognized \$50 million of pre-tax charges associated with this restructuring, of which \$41 million were related to employee severance and benefit costs. The remaining charges were primarily related to operating lease obligations for property that will no longer be utilized. The following table summarizes the charges recognized in 2009 for this restructuring by each of our reportable segments and our Corporate and Other organizations (in millions):

| | |
|---------------------------|-------------|
| Eastern | \$12 |
| Midwest | 11 |
| Southern | 10 |
| Western | 6 |
| Wheelabrator | 1 |
| Corporate and Other | <u>10</u> |
| Total | <u>\$50</u> |

In 2010, we recognized \$2 million of income related to the reversal of pre-tax restructuring charges recorded in 2009. Through December 31, 2010, we had paid all of the employee severance and benefit costs incurred as a result of this restructuring.

13. (Income) Expense from Divestitures, Asset Impairments and Unusual Items

The following table summarizes the major components of “(Income) expense from divestitures, asset impairments and unusual items” for the year ended December 31 for the respective periods (in millions):

| | <u>Years Ended December 31,</u> | | |
|--|---------------------------------|---------------|-------------|
| | <u>2011</u> | <u>2010</u> | <u>2009</u> |
| (Income) expense from divestitures | \$ 1 | \$ (1) | \$— |
| Asset impairments | 9 | — | 83 |
| Other | <u>—</u> | <u>(77)</u> | <u>—</u> |
| | <u>\$10</u> | <u>\$(78)</u> | <u>\$83</u> |

Asset Impairments — During the year ended December 31, 2011, we recognized impairment charges relating primarily to two facilities in our medical waste services business as a result of the closure of one site and of continuing operating losses at the other site. We wrote down the net book values of the sites to their estimated fair values.

Through December 31, 2008, we capitalized \$70 million of accumulated costs associated with the development of a new waste and recycling revenue management system. A significant portion of these costs was specifically associated with the purchase of a license for waste and recycling revenue management software and the efforts required to develop and configure that software for our use. After a failed pilot implementation of the software in one of our smallest Market Areas, the development efforts associated with the revenue management system were suspended in 2007. During 2009, we determined to enhance and improve our existing revenue management system and not pursue alternatives associated with the development and implementation of the licensed software. Accordingly, in 2009, we recognized a non-cash charge of \$51 million, for the abandonment of the licensed software.

We recognized an additional \$32 million of impairment charges during 2009, \$27 million of which was recognized by our Western Group during the fourth quarter of 2009 to fully impair a landfill in California as a

WASTE MANAGEMENT, INC.

NOTES TO CONSOLIDATED FINANCIAL STATEMENTS — (Continued)

result of a change in our expectations for the future operations of the landfill. The remaining impairment charges were primarily attributable to a charge required to write down certain of our investments in portable self-storage operations to their fair value as a result of our acquisition of a controlling financial interest in those operations.

Other — We filed a lawsuit in March 2008 related to the revenue management software implementation that was suspended in 2007 and abandoned in 2009. In April 2010, we settled the lawsuit and received a one-time cash payment. The settlement increased our “Income from operations” for the year ended December 31, 2010 by \$77 million.

14. Accumulated Other Comprehensive Income

The components of accumulated other comprehensive income, which is included as a component of Waste Management, Inc. stockholders’ equity, were as follows (in millions):

| | December 31, | | |
|---|--------------|---------|--------|
| | 2011 | 2010 | 2009 |
| Accumulated unrealized loss on derivative instruments, net of taxes of \$39 for 2011, \$20 for 2010 and \$4 for 2009 | \$ (62) | \$ (33) | \$ (8) |
| Accumulated unrealized gain on available-for-sale securities, net of taxes of \$1 for 2011, \$3 for 2010 and \$1 for 2009 | 2 | 5 | 2 |
| Foreign currency translation adjustments | 243 | 261 | 212 |
| Funded status of post-retirement benefit obligations, net of taxes of \$9 for 2011, \$4 for 2010 and \$1 for 2009 | (11) | (3) | 2 |
| | \$172 | \$230 | \$208 |

15. Capital Stock, Dividends and Share Repurchases

Capital Stock

We have 1.5 billion shares of authorized common stock with a par value of \$0.01 per common share. As of December 31, 2011, we had 460.5 million shares of common stock issued and outstanding. The Board of Directors is authorized to issue preferred stock in series, and with respect to each series, to fix its designation, relative rights (including voting, dividend, conversion, sinking fund, and redemption rights), preferences (including dividends and liquidation) and limitations. We have ten million shares of authorized preferred stock, \$0.01 par value, none of which is currently outstanding.

Dividends

Our quarterly dividends have been declared by our Board of Directors and paid in accordance with our capital allocation programs. Cash dividends declared and paid were \$637 million in 2011, or \$1.36 per common share, \$604 million in 2010, or \$1.26 per common share and \$569 million in 2009, or \$1.16 per common share.

In December 2011, we announced that our Board of Directors expects to increase the per share quarterly dividend from \$0.34 to \$0.355 for dividends declared in 2012. However, all future dividend declarations are at the discretion of the Board of Directors, and depend on various factors, including our net earnings, financial condition, cash required for future business plans and other factors the Board may deem relevant.

WASTE MANAGEMENT, INC.

NOTES TO CONSOLIDATED FINANCIAL STATEMENTS — (Continued)

Share Repurchases

Our share repurchases have been made in accordance with capital allocation programs approved by our Board of Directors. The following is a summary of activity under our stock repurchase programs for each year presented:

| | Years Ended December 31, | | |
|---|--------------------------|-----------------|-----------------|
| | 2011 | 2010 | 2009 |
| Shares repurchased (in thousands) | 17,338 | 14,920 | 7,237 |
| Per share purchase price | \$28.95-\$39.57 | \$31.56-\$37.05 | \$28.06-\$33.80 |
| Total repurchases (in millions) | \$575 | \$501 | \$226 |

We did not repurchase shares during the first half of 2009 given the state of the economy and the financial markets. In the second half of 2009, we resumed repurchases of our common stock following improvements in the economy and capital markets.

In December 2011, the Board of Directors approved up to \$500 million in share repurchases for 2012. However, future share repurchases will be made at the discretion of management, and will depend on factors similar to those considered by the Board in making dividend declarations.

16. Stock-Based Compensation

Employee Stock Purchase Plan

We have an Employee Stock Purchase Plan under which employees that have been employed for at least 30 days may purchase shares of our common stock at a discount. The plan provides for two offering periods for purchases: January through June and July through December. At the end of each offering period, employees are able to purchase shares of our common stock at a price equal to 85% of the lesser of the market value of the stock on the first and last day of such offering period. The purchases are made through payroll deductions, and the number of shares that may be purchased is limited by IRS regulations. The total number of shares issued under the plan for the offering periods in each of 2011, 2010 and 2009 was approximately 920,000, 911,000 and 969,000, respectively. Including the impact of the January 2012 issuance of shares associated with the July to December 2011 offering period, approximately 670,000 shares remain available for issuance under the plan.

Accounting for our Employee Stock Purchase Plan increased annual compensation expense by approximately \$7 million, or \$5 million net of tax, for 2011, by \$7 million, or \$4 million net of tax, for 2010 and by \$6 million, or \$4 million net of tax, for 2009.

Employee Stock Incentive Plans

We grant equity and equity-based awards to our officers, employees and independent directors. The Company's 2004 Stock Incentive Plan, which authorized the issuance of up to 34 million shares of our common stock, terminated by its terms in May 2009, at which time our stockholders approved our 2009 Stock Incentive Plan. The 2009 Plan provides for the issuance of up to 26.2 million shares of our common stock. As of December 31, 2011, approximately 9.5 million shares remain available for issuance under the 2009 Plan. We currently utilize treasury shares to meet the needs of our equity-based compensation programs.

Pursuant to the 2009 Plan, we have the ability to issue stock options, stock appreciation rights and stock awards, including restricted stock, restricted stock units, or RSUs, and performance share units, or PSUs. The terms and conditions of equity awards granted under the 2009 Plan are determined by the Management Development and Compensation Committee of our Board of Directors.

WASTE MANAGEMENT, INC.

NOTES TO CONSOLIDATED FINANCIAL STATEMENTS — (Continued)

The Company grants equity awards to certain key employees as part of its long-term incentive plan, or LTIP. The annual LTIP awards granted in 2009 included a combination of RSUs and PSUs. In 2010, we re-introduced stock options as a component of equity compensation, and in 2010 and 2011, key employees were granted a combination of PSUs and stock options. In 2009, the annual LTIP award made to the Company's senior leadership team, which generally includes the Company's executive officers, was comprised solely of PSUs. In 2010 and 2011, the annual LTIP award to the Company's senior leadership team included a combination of PSUs and stock options. During the reported periods, the Company has also granted restricted stock units and stock options to employees working on key initiatives; in connection with new hires and promotions; and to field-based managers.

Restricted Stock Units — A summary of our RSUs is presented in the table below (units in thousands):

| | Years Ended December 31, | | | | | |
|---------------------------------------|--------------------------|--------------------------------------|------------|--------------------------------------|--------------|--------------------------------------|
| | 2011 | | 2010 | | 2009 | |
| | Units | Weighted Average Fair Value | Units | Weighted Average Fair Value | Units | Weighted Average Fair Value |
| Unvested, beginning of year | 586 | \$27.61 | 1,030 | \$30.76 | 1,121 | \$33.46 |
| Granted | 6 | \$31.65 | 8 | \$34.25 | 369 | \$23.66 |
| Vested(a) | (253) | \$32.62 | (428) | \$35.37 | (412) | \$31.49 |
| Forfeited | (22) | \$26.12 | (24) | \$26.54 | (48) | \$32.81 |
| Unvested, end of year | <u>317</u> | <u>\$23.60</u> | <u>586</u> | <u>\$27.61</u> | <u>1,030</u> | <u>\$30.76</u> |

(a) The total fair market value of RSUs that vested during the years ended December 31, 2011, 2010 and 2009 was \$9 million, \$14 million and \$13 million, respectively. Net of units deferred and units used for payment of associated taxes, we issued approximately 162,000, 264,000 and 260,000 shares of common stock for RSUs that vested during the years ended December 31, 2011, 2010 and 2009, respectively.

RSUs provide award recipients with dividend equivalents during the vesting period, but the units may not be voted or sold until time-based vesting restrictions have lapsed. RSUs primarily provide for three-year cliff vesting. Unvested units are subject to forfeiture in the event of voluntary or for-cause termination. RSUs are subject to pro-rata vesting upon an employee's retirement or involuntary termination other than for cause and become immediately vested in the event of an employee's death or disability.

Compensation expense associated with RSUs is measured based on the grant-date fair value of our common stock and is recognized on a straight-line basis over the required employment period, which is generally the vesting period. Compensation expense is only recognized for those awards that we expect to vest, which we estimate based upon an assessment of current period and historical forfeitures.

WASTE MANAGEMENT, INC.

NOTES TO CONSOLIDATED FINANCIAL STATEMENTS — (Continued)

Performance Share Units — PSUs are payable in shares of common stock after the end of a three-year performance period and after the Company’s financial results for the entire performance period are reported, typically in mid to late February of the succeeding year. At the end of the performance period, the number of shares awarded can range from 0% to 200% of the targeted amount, depending on the Company’s performance against pre-established financial targets. A summary of our PSUs is presented in the table below (units in thousands):

| | Years Ended December 31, | | | | | |
|---------------------------------------|--------------------------|--------------------------------------|--------------|--------------------------------------|--------------|--------------------------------------|
| | 2011 | | 2010 | | 2009 | |
| | Units(a) | Weighted Average Fair Value | Units(b) | Weighted Average Fair Value | Units(c) | Weighted Average Fair Value |
| Unvested, beginning of year | 1,740 | \$26.72 | 2,254 | \$27.68 | 2,009 | \$34.78 |
| Granted | 380 | \$37.19 | 690 | \$33.49 | 1,159 | \$22.66 |
| Vested(d) | (1,070) | \$22.66 | — | \$ — | (827) | \$37.28 |
| Expired without vesting | — | \$ — | (1,064) | \$32.92 | — | \$ — |
| Forfeited | (69) | \$31.31 | (140) | \$28.41 | (87) | \$33.59 |
| Unvested, end of year | <u>981</u> | <u>\$34.85</u> | <u>1,740</u> | <u>\$26.72</u> | <u>2,254</u> | <u>\$27.68</u> |

- (a) The Company’s financial results for the three-year performance period ended December 31, 2011, as measured for purposes of these awards, are anticipated to be lower than the target levels established but in excess of the threshold performance criteria. Accordingly, recipients of PSU awards with the performance period ended December 31, 2011 will be entitled to receive an estimated payout of greater than 60% but less than 100% of the vested PSUs. The payout will occur in late February 2012.
- (b) The Company’s financial results for the three-year performance period ended December 31, 2010, as measured for purposes of these awards, did not meet the threshold performance criteria for such PSUs, and as a result, the PSUs with the performance period ended December 31, 2010 expired without vesting.
- (c) The Company’s financial results for the three-year performance period ended December 31, 2009, as measured for purposes of these awards, were lower than the target levels established but in excess of the threshold performance criteria. Accordingly, recipients of PSU awards with the performance period ended December 31, 2009 were entitled to receive a payout of approximately 84% of the vested PSUs. In early 2010, we issued approximately 443,000 shares of common stock for these vested PSUs, net of units deferred and units used for payment of associated taxes.
- (d) The PSUs that vested in 2009 had a fair market value of \$23 million.

PSUs have no voting rights. PSUs receive dividend equivalents that are paid out in cash based on actual performance at the end of the awards’ performance period. In the case of the PSUs with the performance period ended December 31, 2010 that expired without vesting, no dividend equivalents were paid. PSUs are payable to an employee (or his beneficiary) upon death or disability as if that employee had remained employed until the end of the performance period, are subject to pro-rata vesting upon an employee’s retirement or involuntary termination other than for cause and are subject to forfeiture in the event of voluntary or for-cause termination.

Compensation expense associated with PSUs that continue to vest based on future performance is measured based on the grant-date fair value of our common stock. Compensation expense is recognized ratably over the performance period based on our estimated achievement of the established performance criteria. Compensation expense is only recognized for those awards that we expect to vest, which we estimate based upon an assessment of both the probability that the performance criteria will be achieved and current period and historical forfeitures.

Deferred Units — Recipients can elect to defer some or all of the vested RSU or PSU awards until a specified date or dates they choose. Deferred amounts are not invested, nor do they earn interest, but deferred amounts do earn dividend equivalents during deferral. Deferred amounts are paid out in shares of common stock

WASTE MANAGEMENT, INC.

NOTES TO CONSOLIDATED FINANCIAL STATEMENTS — (Continued)

at the end of the deferral period. At December 31, 2011, 2010 and 2009 we had approximately 372,000, 371,000 and 315,000, respectively, vested deferred units outstanding.

Stock Options — Prior to 2005, stock options were the primary form of equity-based compensation we granted to our employees. In 2010, the Management Development and Compensation Committee decided to re-introduce stock options as a component of our LTIP awards. All of our stock option awards granted prior to 2010 have vested, with the exception of any grants pursuant to the reload feature discussed in footnote (a) to the table below. The stock options granted in 2010 and 2011 primarily vest in 25% increments on the first two anniversaries of the date of grant and the remaining 50% will vest on the third anniversary. The exercise price of the options is the average of the high and low market value of our common stock on the date of grant, and the options have a term of 10 years. A summary of our stock options is presented in the table below (shares in thousands):

| | Years Ended December 31, | | | | | |
|--|--------------------------|--|--------------|--|--------------|--|
| | 2011 | | 2010 | | 2009 | |
| | Shares | Weighted Average Exercise Price | Shares | Weighted Average Exercise Price | Shares | Weighted Average Exercise Price |
| Outstanding, beginning of year | 9,957 | \$28.95 | 8,800 | \$25.98 | 11,045 | \$26.97 |
| Granted(a) (b) | 6,597 | \$37.04 | 3,901 | \$33.56 | 1 | \$27.90 |
| Exercised(c) | (1,900) | \$26.46 | (2,454) | \$25.17 | (1,285) | \$30.20 |
| Forfeited or expired | (399) | \$33.05 | (290) | \$32.88 | (961) | \$39.62 |
| Outstanding, end of year(d) | <u>14,255</u> | <u>\$32.91</u> | <u>9,957</u> | <u>\$28.95</u> | <u>8,800</u> | <u>\$25.98</u> |
| Exercisable, end of year(e) | <u>5,176</u> | <u>\$27.46</u> | <u>6,286</u> | <u>\$26.25</u> | <u>8,798</u> | <u>\$25.98</u> |

- (a) Although we stopped granting stock options from 2005 through 2009, some of our outstanding options granted in 2003 and 2004 have a reload feature that provides for the automatic grant of a new stock option award when the exercise price of the existing stock option is paid using already owned shares of common stock. The new option award is for the same number of shares used as payment of the exercise price and has the same expiration date as the original option that was reloaded.
- (b) The weighted average grant-date fair value of stock options granted during the years ended December 31, 2011, 2010 and 2009 was \$5.88, \$5.83 and \$4.03, respectively.
- (c) The aggregate intrinsic value of stock options exercised during the years ended December 31, 2011, 2010 and 2009 was \$20 million, \$25 million and \$12 million, respectively.
- (d) Stock options outstanding as of December 31, 2011 have a weighted average remaining contractual term of 6.59 years and an aggregate intrinsic value of \$29 million based on the market value of our common stock on December 31, 2011.
- (e) The aggregate intrinsic value of stock options exercisable as of December 31, 2011 was \$28 million.

We received cash proceeds of \$45 million, \$54 million and \$20 million during the years ended December 31, 2011, 2010 and 2009, respectively, from our employees' stock option exercises. We also realized tax benefits from these stock option exercises during the years ended December 31, 2011, 2010 and 2009 of \$8 million, \$10 million and \$5 million, respectively. These amounts have been presented as cash inflows in the "Cash flows from financing activities" section of our Consolidated Statements of Cash Flows.

WASTE MANAGEMENT, INC.

NOTES TO CONSOLIDATED FINANCIAL STATEMENTS — (Continued)

Exercisable stock options at December 31, 2011, were as follows (shares in thousands):

| <u>Range of Exercise Prices</u> | <u>Shares</u> | <u>Weighted Average Exercise Price</u> | <u>Weighted Average Remaining Years</u> |
|---------------------------------|---------------|--|---|
| \$19.61-\$20.00 | 936 | \$19.61 | 1.18 |
| \$20.01-\$30.00 | 3,321 | \$27.90 | 1.54 |
| \$30.01-\$39.93 | <u>919</u> | \$33.88 | 7.96 |
| \$19.61-\$39.93 | <u>5,176</u> | \$27.46 | 2.61 |

All unvested stock options granted in 2010 and 2011 shall become exercisable upon the award recipient's death or disability. In the event of a recipient's retirement, stock options shall continue to vest pursuant to the original schedule set forth in the award agreement. If the recipient is terminated by the Company without cause, the recipient shall be entitled to exercise all 2010 and 2011 stock options outstanding and exercisable prior to such termination. All outstanding stock options, whether exercisable or not, are forfeited upon termination with cause.

We account for our employee stock options under the fair value method of accounting using a Black-Scholes methodology to measure stock option expense at the date of grant. The fair value of the stock options at the date of grant is amortized to expense over the vesting period. The following table presents the weighted average assumptions used to value employee stock options granted during the years ended December 31, 2011 and 2010 under the Black-Scholes valuation model:

| | <u>Years Ended December 31,</u> | |
|-------------------------------|-------------------------------------|-------------|
| | <u>2011</u> | <u>2010</u> |
| Expected option life | 5.4 years | 5.7 years |
| Expected volatility | 24.2% | 24.8% |
| Expected dividend yield | 3.7% | 3.8% |
| Risk-free interest rate | 2.3% | 2.9% |

The Company bases its expected option life on the expected exercise and termination behavior of its optionees and an appropriate model of the Company's future stock price. The expected volatility assumption is derived from the historical volatility of the Company's common stock over the most recent period commensurate with the estimated expected life of the Company's stock options, combined with other relevant factors including implied volatility in market-traded options on the Company's stock. The dividend yield is the annual rate of dividends per share over the exercise price of the option as of the grant date.

For the years ended December 31, 2011, 2010 and 2009, we recognized \$38 million, \$28 million, and \$22 million, respectively, of compensation expense associated with RSU, PSU and stock option awards as a component of "Selling, general and administrative" expenses in our Consolidated Statement of Operations. Our "Provision for income taxes" for the years ended December 31, 2011, 2010 and 2009 includes related deferred income tax benefits of \$13 million, \$11 million and \$9 million, respectively. We have not capitalized any equity-based compensation costs during the years ended December 31, 2011, 2010 and 2009.

Compensation expense recognized in 2011 was higher than expense recognized in 2010 primarily due to expense resulting from the significant increase in the number of stock options granted by the Company in 2011 over the number granted in 2010 and the increase in retirement-eligible employees receiving stock option awards, offset partially by a decrease in the number of PSUs granted in 2011. According to the terms of the stock option award agreement, retirement-eligible employees are not required to provide any future service to vest in these awards and, as a result, we recognized all of the associated compensation expense for retirement-eligible employees on the date of grant. As of December 31, 2011, we estimate that a total of approximately \$37 million

WASTE MANAGEMENT, INC.

NOTES TO CONSOLIDATED FINANCIAL STATEMENTS — (Continued)

of currently unrecognized compensation expense will be recognized over a weighted average period of 1.8 years for unvested RSU, PSU and stock option awards issued and outstanding.

Non-Employee Director Plans

Our non-employee directors currently receive annual grants of shares of our common stock, payable in two equal installments, under the 2009 Plan described above.

17. Earnings Per Share

Basic and diluted earnings per share were computed using the following common share data (shares in millions):

| | Years Ended December 31, | | |
|--|---------------------------------|-------------|-------------|
| | 2011 | 2010 | 2009 |
| Number of common shares outstanding at year-end | 460.5 | 475.0 | 486.1 |
| Effect of using weighted average common shares outstanding | 9.2 | 5.2 | 5.1 |
| Weighted average basic common shares outstanding | 469.7 | 480.2 | 491.2 |
| Dilutive effect of equity-based compensation awards and other contingently issuable shares | 1.7 | 2.0 | 2.4 |
| Weighted average diluted common shares outstanding | 471.4 | 482.2 | 493.6 |
| Potentially issuable shares | 17.0 | 12.8 | 13.2 |
| Number of anti-dilutive potentially issuable shares excluded from diluted common shares outstanding | 9.8 | 3.6 | 0.3 |

18. Fair Value Measurements

Assets and Liabilities Accounted for at Fair Value

Authoritative guidance associated with fair value measurements provides a framework for measuring fair value and establishes a fair value hierarchy that prioritizes the inputs used to measure fair value, giving the highest priority to unadjusted quoted prices in active markets for identical assets or liabilities (Level 1 inputs) and the lowest priority to unobservable inputs (Level 3 inputs).

WASTE MANAGEMENT, INC.

NOTES TO CONSOLIDATED FINANCIAL STATEMENTS — (Continued)

We use valuation techniques that maximize the use of observable inputs and minimize the use of unobservable inputs. In measuring the fair value of our assets and liabilities, we use market data or assumptions that we believe market participants would use in pricing an asset or liability, including assumptions about risk when appropriate. Our assets and liabilities that are measured at fair value on a recurring basis include the following (in millions):

| | Fair Value Measurements at December 31, 2011 Using | | | |
|---|---|---|---|--|
| | Total | Quoted Prices in Active Markets (Level 1) | Significant Other Observable Inputs (Level 2) | Significant Unobservable Inputs (Level 3) |
| Assets: | | | | |
| Cash equivalents | \$120 | \$120 | \$— | \$— |
| Available-for-sale securities | 154 | 154 | — | — |
| Interest rate derivatives | 73 | — | 73 | — |
| Electricity commodity derivatives | <u>5</u> | <u>—</u> | <u>5</u> | <u>—</u> |
| Total assets | <u>\$352</u> | <u>\$274</u> | <u>\$78</u> | <u>\$—</u> |
| Liabilities: | | | | |
| Interest rate derivatives | \$ 74 | \$ — | \$74 | \$— |
| Foreign currency derivatives | <u>2</u> | <u>—</u> | <u>2</u> | <u>—</u> |
| Total liabilities | <u>\$ 76</u> | <u>\$ —</u> | <u>\$76</u> | <u>\$—</u> |

| | Fair Value Measurements at December 31, 2010 Using | | | |
|---|---|---|---|--|
| | Total | Quoted Prices in Active Markets (Level 1) | Significant Other Observable Inputs (Level 2) | Significant Unobservable Inputs (Level 3) |
| Assets: | | | | |
| Cash equivalents | \$468 | \$468 | \$— | \$— |
| Available-for-sale securities | 148 | 148 | — | — |
| Interest rate derivatives | <u>38</u> | <u>—</u> | <u>38</u> | <u>—</u> |
| Total assets | <u>\$654</u> | <u>\$616</u> | <u>\$38</u> | <u>\$—</u> |
| Liabilities: | | | | |
| Interest rate derivatives | \$ 24 | \$ — | \$24 | \$— |
| Foreign currency derivatives | 3 | — | 3 | — |
| Electricity commodity derivatives | <u>1</u> | <u>—</u> | <u>1</u> | <u>—</u> |
| Total liabilities | <u>\$ 28</u> | <u>\$ —</u> | <u>\$28</u> | <u>\$—</u> |

WASTE MANAGEMENT, INC.

NOTES TO CONSOLIDATED FINANCIAL STATEMENTS — (Continued)

Cash Equivalents

Cash equivalents are reflected at fair value in our Consolidated Financial Statements based upon quoted market prices and consist primarily of money market funds that invest in U.S. government obligations with original maturities of three months or less.

Available-for-Sale Securities

Available for-sale securities are recorded at fair value based on quoted market prices. These assets include restricted trusts and escrow accounts invested in money market mutual funds, equity-based mutual funds and other debt and equity securities. The fair value of our restricted trust and escrow accounts approximates our cost basis in the investments.

Interest Rate Derivatives

As of December 31, 2011, we are party to (i) fixed-to-floating interest rate swaps that are designated as fair value hedges of our currently outstanding senior notes; and (ii) forward-starting interest rate swaps that are designated as cash flow hedges of anticipated interest payments for future fixed-rate debt issuances. Our fixed-to-floating interest rate swaps and forward-starting interest rate swaps are LIBOR-based instruments. Accordingly, these derivatives are valued using a third-party pricing model that incorporates information about LIBOR yield curves for each instrument's respective term. The third-party pricing model used to value our interest rate derivatives also incorporates Company and counterparty credit valuation adjustments, as appropriate. Counterparties to our interest rate derivatives are financial institutions who participate in our \$2.0 billion revolving credit facility. Valuations of our interest rate derivatives may fluctuate significantly from period-to-period due to volatility in underlying interest rates, which are driven by market conditions and the scheduled maturities of the derivatives. Refer to Note 8 for additional information regarding our interest rate derivatives.

Foreign Currency Derivatives

Our foreign currency derivatives are valued using a third-party pricing model that incorporates information about forward Canadian dollar exchange prices as of the reporting date. The third-party pricing model used to value our foreign currency derivatives also incorporates Company and counterparty credit valuation adjustments, as appropriate. Counterparties to these contracts are financial institutions who participate in our \$2.0 billion revolving credit facility. Valuations may fluctuate significantly from period-to-period due to volatility in the Canadian dollar to U.S. dollar exchange rate. Refer to Note 8 for additional information regarding our foreign currency derivatives.

Electricity Commodity Derivatives

As of December 31, 2011, we are party to fixed-to-floating electricity commodity derivatives to hedge the variability in revenues and cash flows caused by fluctuations in the market prices for electricity. These derivative instruments are valued using third-party pricing models that incorporate forward power curves published by Platts, as well as congestion rates where appropriate. The third-party pricing models also incorporate Company and counterparty credit valuation adjustments, as appropriate. Counterparties to our electricity commodity derivatives are either power marketing arms of investor-owned utilities or power trading desks at various financial institutions. Valuations of the Company's electricity commodity derivatives may fluctuate significantly from period-to-period due to volatility in the market price of electricity caused by factors such as demand and supply movements, changes in the price of natural gas, and weather related events, among others. Refer to Note 8 for additional information regarding our electricity commodity derivatives.

Fair Value of Debt

At December 31, 2011 the carrying value of our debt was approximately \$9.8 billion compared with approximately \$8.9 billion at December 31, 2010. The carrying value of our debt includes adjustments for both

WASTE MANAGEMENT, INC.

NOTES TO CONSOLIDATED FINANCIAL STATEMENTS — (Continued)

the unamortized fair value adjustments related to terminated hedge arrangements and fair value adjustments of debt instruments that are currently hedged.

The estimated fair value of our debt was approximately \$10.8 billion at December 31, 2011 and approximately \$9.2 billion at December 31, 2010. The estimated fair value of our senior notes is based on quoted market prices. The carrying value of remarketable debt approximates fair value due to the short-term nature of the interest rates. The fair value of our other debt is estimated using discounted cash flow analysis, based on rates we would currently pay for similar types of instruments. The increase in the fair value of our debt when comparing December 31, 2011 with December 31, 2010 is primarily related to \$753 million of net borrowings during 2011 associated with our senior notes. Increases in market prices for corporate debt securities and decreases in current market rates on fixed-rate tax-exempt bonds also contributed to the increase in the fair value of debt for the reported period.

Although we have determined the estimated fair value amounts using available market information and commonly accepted valuation methodologies, considerable judgment is required in interpreting market data to develop the estimates of fair value. Accordingly, our estimates are not necessarily indicative of the amounts that we, or holders of the instruments, could realize in a current market exchange. The use of different assumptions and/or estimation methodologies could have a material effect on the estimated fair values. The fair value estimates are based on information available as of December 31, 2011 and December 31, 2010. These amounts have not been revalued since those dates, and current estimates of fair value could differ significantly from the amounts presented.

19. Acquisitions and Divestitures

Current Year Acquisitions

We continue to pursue the acquisition of businesses that are accretive to our solid waste operations and enhance and expand our existing service offerings. In 2011, we acquired businesses primarily related to our collection and recycling operations, including the acquisition of Oakleaf discussed below. Total consideration, net of cash acquired, for all acquisitions was \$893 million, which included \$839 million in cash payments, a liability for additional cash payments with a preliminarily estimated fair value of \$47 million, and assumed liabilities of \$7 million. In 2011, we paid \$8 million in deposits for acquisitions that had not closed as of December 31, 2011. The additional cash payments are contingent upon achievement by the acquired businesses of certain negotiated goals, which generally included targeted revenues. At the dates of acquisition, our estimated maximum obligations for the contingent cash payments were \$49 million. As of December 31, 2011, we had paid \$12 million of this contingent consideration. In 2011, we also paid \$8 million of contingent consideration associated with acquisitions completed in 2010 and 2009.

The allocation of purchase price was primarily to “Property and equipment,” which had an estimated fair value of \$225 million; “Other intangible assets,” which had an estimated fair value of \$225 million; and “Goodwill” of \$497 million. Goodwill is primarily a result of expected synergies from combining the acquired businesses with our existing operations and is tax deductible, except for the \$327 million recognized from the Oakleaf acquisition, which is not deductible for income tax purposes. Other intangible assets included \$166 million of customer contracts and customer lists, \$29 million of covenants not-to-compete and \$30 million of licenses, permits and other.

Acquisition of Oakleaf Global Holdings

On July 28, 2011, we paid \$432 million, net of cash received of \$4 million and inclusive of certain adjustments, to acquire Oakleaf. Oakleaf provides outsourced waste and recycling services through a nationwide network of third-party haulers. The operations we acquired generated approximately \$580 million in revenues in 2010. We acquired Oakleaf to advance our growth and transformation strategies and increase our national accounts customer base while enhancing our ability to provide comprehensive environmental solutions. For the year ended December 31, 2011, we incurred \$1 million of acquisition-related costs, which are classified as “Selling, general

WASTE MANAGEMENT, INC.

NOTES TO CONSOLIDATED FINANCIAL STATEMENTS — (Continued)

and administrative” expenses. Since the acquisition date, Oakleaf has recognized revenues of \$265 million and net income of less than \$1 million, which are included in our Consolidated Statement of Operations.

The following table shows adjustments to the preliminary allocation of the purchase price of Oakleaf to tangible and intangible assets acquired and liabilities assumed based on their estimated fair value from September 30, 2011 to December 31, 2011 (in millions):

| | <u>September 30, 2011</u> | <u>Adjustments(a)</u> | <u>December 31, 2011</u> |
|--|---------------------------|-----------------------|--------------------------|
| Accounts and other receivables | \$ 68 | \$ 2 | \$ 70 |
| Other current assets | 28 | — | 28 |
| Property and equipment | 77 | (5) | 72 |
| Goodwill | 320 | 7 | 327 |
| Other intangible assets | 92 | (5) | 87 |
| Accounts payable | (80) | (2) | (82) |
| Accrued liabilities | (48) | — | (48) |
| Deferred income taxes, net | (13) | 3 | (10) |
| Other liabilities | <u>(12)</u> | <u>—</u> | <u>(12)</u> |
| Total purchase price | <u>\$432</u> | <u>\$—</u> | <u>\$432</u> |

(a) The purchase price adjustments relate primarily to changes in the valuation of the customer and vendor relationships and evaluation of physical and market conditions of equipment.

The purchase price allocation is still preliminary and may change. The following table presents the preliminary allocation of the purchase price to intangible assets (amounts in millions, except for amortization periods):

| | <u>Amount</u> | <u>Weighted Average Amortization Periods (in Years)</u> |
|---|---------------|---|
| Customer relationships | \$74 | 10.0 |
| Vendor relationships | 4 | 10.0 |
| Trademarks | <u>9</u> | 15.0 |
| Total intangible assets subject to amortization | <u>\$87</u> | 10.5 |

Goodwill of \$327 million was calculated as the excess of the consideration paid over the net assets recognized and represents the future economic benefits arising from other assets acquired that could not be individually identified and separately recognized. Goodwill is a result of expected synergies from combining the Company’s operations with Oakleaf’s national accounts customer base and vendor network. The vendor-hauler network expands our partnership with third-party service providers. In many cases we can provide vendor-haulers with opportunities to maintain and increase their business by utilizing our extensive post-collection network. We believe this will generate significant benefits for the Company and for the vendor-haulers. Based on our preliminary valuation, goodwill has been assigned to our four geographic Groups as they are expected to benefit from the synergies of the combination.

WASTE MANAGEMENT, INC.

NOTES TO CONSOLIDATED FINANCIAL STATEMENTS — (Continued)

The following pro forma consolidated results of operations have been prepared as if the acquisition of Oakleaf occurred at January 1, 2010 (in millions, except per share amounts):

| | Years Ended December 31, | |
|---|---------------------------------|-------------|
| | 2011 | 2010 |
| Operating revenues | \$13,693 | \$13,059 |
| Net income attributable to Waste Management, Inc. | 955 | 935 |
| Basic earnings per common share | 2.03 | 1.95 |
| Diluted earnings per common share | 2.03 | 1.94 |

Prior Year Acquisitions

In 2010, we acquired businesses primarily related to our collection and waste-to-energy operations. Total consideration, net of cash acquired, for acquisitions was \$427 million, which included \$379 million in cash payments, \$20 million in contributed assets, a liability for additional cash payments with an estimated fair value of \$23 million, and assumed liabilities of \$5 million. The additional cash payments are contingent upon achievement by the acquired businesses of certain negotiated goals, which generally included targeted revenues. At the date of acquisition, our estimated maximum obligations for the contingent cash payments were \$23 million. As of December 31, 2010, we had paid \$8 million of this contingent consideration. In 2010, we also paid \$20 million of contingent consideration associated with acquisitions completed in 2009.

The allocation of purchase price was primarily to “Property and equipment,” which had an estimated fair value of \$279 million; “Other intangible assets,” which had an estimated fair value of \$98 million; and “Goodwill” of \$77 million. Goodwill is primarily a result of expected synergies from combining the acquired businesses with our existing operations and is tax deductible. Other intangible assets included \$35 million of customer contracts and customer lists, \$8 million of covenants not-to-compete and \$55 million of licenses, permits and other.

In 2009, we acquired businesses primarily related to our collection operations. Total consideration, net of cash acquired, for acquisitions was \$329 million, which included \$259 million in cash payments, a liability for additional cash payments with an estimated fair value of \$46 million, and assumed liabilities of \$24 million. The additional cash payments are contingent upon achievement by the acquired businesses of certain negotiated goals, which generally included targeted revenues. At the date of acquisition, our estimated obligations for the contingent cash payments were between \$42 million and \$56 million. As of December 31, 2009, we had paid \$15 million of this contingent consideration. In 2009, we also paid \$7 million of contingent consideration associated with acquisitions completed in 2008.

The allocation of purchase price was primarily to “Property and equipment,” which had an estimated fair value of \$102 million; “Other intangible assets,” which had an estimated fair value of \$105 million; and “Goodwill” of \$125 million. Goodwill is primarily a result of expected synergies from combining the acquired businesses with our existing operations and is tax deductible. Other intangible assets included \$66 million of customer contracts and customer lists, \$19 million of covenants not-to-compete and \$20 million of licenses, permits and other.

Our 2009 acquisitions included the purchase of the remaining equity interest in one of our portable self-storage investments, increasing our equity interest in this entity from 50% to 100%. As a result of this acquisition, we recognized a \$4 million loss for the remeasurement of the fair value of our initial equity investment, which was determined to be \$5 million. This loss was recognized as a component of “(Income) expense from divestitures, asset impairments and unusual items” in our Consolidated Statement of Operations.

Divestitures

The aggregate sales price for divestitures of operations was \$32 million in 2011, \$1 million in 2010 and \$1 million in 2009. The proceeds from these sales for 2011 were comprised of assets acquired in exchanges of assets. For 2010 and 2009, the proceeds from these sales were comprised substantially of cash. We recognized net losses on

WASTE MANAGEMENT, INC.

NOTES TO CONSOLIDATED FINANCIAL STATEMENTS — (Continued)

these divestitures of \$1 million in 2011 and net gains on these divestitures of \$1 million in 2010. The impact to our 2009 income from operations of gains and losses on divestitures was less than \$1 million. These divestitures were made as part of our initiative to improve or divest certain underperforming and non-strategic operations.

20. Variable Interest Entities

Following is a description of our financial interests in variable interest entities that we consider significant, including (i) those for which we have determined that we are the primary beneficiary of the entity and, therefore, have consolidated the entities into our financial statements; and (ii) those that represent a significant interest in an unconsolidated entity.

Consolidated Variable Interest Entities

Waste-to-Energy LLCs — In June 2000, two limited liability companies were established to purchase interests in existing leveraged lease financings at three waste-to-energy facilities that we lease, operate and maintain. We own a 0.5% interest in one of the LLCs (“LLC I”) and a 0.25% interest in the second LLC (“LLC II”). John Hancock Life Insurance Company (“Hancock”) owns 99.5% of LLC I, and 99.75% of LLC II is owned by LLC I and the CIT Group (“CIT”). In 2000, Hancock and CIT made an initial investment of \$167 million in the LLCs, which was used to purchase the three waste-to-energy facilities and assume the seller’s indebtedness. Under the LLC agreements, the LLCs shall be dissolved upon the occurrence of any of the following events: (i) a written decision of all members of the LLCs; (ii) December 31, 2063; (iii) a court’s dissolution of the LLCs; or (iv) the LLCs ceasing to own any interest in the waste-to-energy facilities.

Income, losses and cash flows of the LLCs are allocated to the members based on their initial capital account balances until Hancock and CIT achieve targeted returns; thereafter, we will receive 80% of the earnings of each of the LLCs and Hancock and CIT will be allocated the remaining 20%, proportionate to their respective equity interests. All capital allocations made through December 31, 2011 have been based on initial capital account balances as the target returns have not yet been achieved.

Our obligations associated with our interests in the LLCs are primarily related to the lease of the facilities. In addition to our minimum lease payment obligations, we are required to make cash payments to the LLCs, for differences between fair market rents and our minimum lease payments. These payments are subject to adjustment based on factors that include the fair market value of rents for the facilities and lease payments made through the re-measurement dates. In addition, we may also be required under certain circumstances to make capital contributions to the LLCs based on differences between the fair market value of the facilities and defined termination values as provided for in the underlying lease agreements, although we believe the likelihood of the occurrence of these circumstances is remote.

We have determined that we are the primary beneficiary of the LLCs and consolidate these entities in our Consolidated Financial Statements because (i) all of the equity owners of the LLCs are considered related parties for purposes of applying this accounting guidance; (ii) the equity owners share power over the significant activities of the LLCs; and (iii) we are the entity within the related party group whose activities are most closely associated with the LLCs.

As of December 31, 2011, our Consolidated Balance Sheet includes \$308 million of net property and equipment associated with the LLCs’ waste-to-energy facilities and \$246 million in noncontrolling interests associated with Hancock’s and CIT’s interests in the LLCs. As of December 31, 2011, all debt obligations of the LLCs have been paid in full and, therefore, the LLCs have no liabilities. During each of the years ended December 31, 2011, 2010, and 2009, we recognized expense of \$50 million for Hancock’s and CIT’s noncontrolling interests in the LLCs’ earnings. The LLCs’ earnings relate to the rental income generated from leasing the facilities to our subsidiaries, reduced by depreciation expense. The LLCs’ rental income is eliminated in WM’s consolidation.

WASTE MANAGEMENT, INC.

NOTES TO CONSOLIDATED FINANCIAL STATEMENTS — (Continued)

Significant Unconsolidated Variable Interest Entities

Investment in Refined Coal Facility — In January 2011, we acquired a noncontrolling interest in a limited liability company, which was established to invest in and manage a refined coal facility. Along with the other equity investor, we support the operations of the entity in exchange for a pro-rata share of the tax credits it generates. Our initial consideration for this investment consisted of a cash payment of \$48 million. At December 31, 2011, our investment balance was \$35 million, representing our current maximum pre-tax exposure to loss. Under the terms and conditions of the transaction, we do not believe that we have any material exposure to loss. Future contributions will commence once certain levels of tax credits have been generated and will continue through the expiration of the tax credits under Section 45 of the Internal Revenue Code, which occurs at the end of 2019. We are only obligated to make future contributions to the extent tax credits are generated. We determined that we are not the primary beneficiary of this entity as we do not have the power to individually direct the entity's activities. Accordingly, we account for this investment under the equity method of accounting and do not consolidate the entity. Additional information related to this investment is discussed in Note 9.

Investment in Federal Low-income Housing Tax Credits — In April 2010, we acquired a noncontrolling interest in a limited liability company established to invest in and manage low-income housing properties. We support the operations of the entity in exchange for a pro-rata share of the tax credits it generates. Our target return on the investment is guaranteed and, therefore, we do not believe that we have any material exposure to loss. Our consideration for this investment totaled \$221 million, which was comprised of a \$215 million note payable and an initial cash payment of \$6 million. At December 31, 2011, our investment balance was \$178 million and our debt balance was \$176 million. We determined that we are not the primary beneficiary of this entity as we do not have the power to individually direct the entity's activities. Accordingly, we account for this investment under the equity method of accounting and do not consolidate the entity. Additional information related to this investment is discussed in Note 9.

Trusts for Final Capping, Closure, Post-Closure or Environmental Remediation Obligations — We have significant financial interests in trust funds that were created to settle certain of our final capping, closure, post-closure or environmental remediation obligations. We have determined that we are not the primary beneficiary of certain of these trust funds because power over the trusts' significant activities is shared.

The deconsolidation of these variable interest entities as of January 1, 2010, in accordance with the new FASB guidance discussed in Note 2, decreased our restricted trust and escrow accounts by \$109 million; increased investments in unconsolidated entities by \$27 million; increased receivables, principally long-term, by \$51 million; and decreased noncontrolling interests by \$31 million. Beginning in 2010, our interests in these variable interest entities have been accounted for as investments in unconsolidated entities and receivables. These amounts are recorded in "Other receivables" and as long-term "Other assets" in our Consolidated Balance Sheet. Our investments and receivables related to the trusts had an aggregate carrying value of \$105 million as of January 1, 2010, \$103 million as of December 31, 2010 and \$107 million as of December 31, 2011. We continue to reflect our interests in the unrealized gains and losses on available-for-sale securities held by these trusts as a component of accumulated other comprehensive income. The deconsolidation of these variable interest entities has not materially affected our financial position, results of operations or cash flows for the periods presented.

As the party with primary responsibility to fund the related final capping, closure, post-closure or environmental remediation activities, we are exposed to risk of loss as a result of potential changes in the fair value of the assets of the trust. The fair value of trust assets can fluctuate due to (i) changes in the market value of the investments held by the trusts and (ii) credit risk associated with trust receivables. Although we are exposed to changes in the fair value of the trust assets, we currently expect the trust funds to continue to meet the statutory requirements for which they were established.

WASTE MANAGEMENT, INC.

NOTES TO CONSOLIDATED FINANCIAL STATEMENTS — (Continued)

21. Segment and Related Information

We currently manage and evaluate our operations primarily through our Eastern, Midwest, Southern, Western and Wheelabrator Groups. These five Groups are presented below as our reportable segments. Our four geographic operating Groups provide collection, transfer, disposal (in both solid waste and hazardous waste landfills) and recycling services. Our fifth Group is the Wheelabrator Group, which provides waste-to-energy services and manages waste-to-energy facilities and independent power production plants. We serve residential, commercial, industrial, and municipal customers throughout North America. The operations not managed through our five operating Groups, including the Oakleaf operations we acquired on July 28, 2011, are presented herein as "Other." See Note 19 for additional information related to our acquisition of Oakleaf.

Summarized financial information concerning our reportable segments for the respective years ended December 31 is shown in the following table (in millions):

| | <u>Gross Operating Revenues</u> | <u>Intercompany Operating Revenues(c)</u> | <u>Net Operating Revenues</u> | <u>Income from Operations (d),(e)</u> | <u>Depreciation and Amortization</u> | <u>Capital Expenditures (f)</u> | <u>Total Assets (g),(h)</u> |
|------------------------------|---|---|---------------------------------------|---|--|---|-------------------------------------|
| 2011 | | | | | | | |
| Eastern | \$ 3,115 | \$ (519) | \$ 2,596 | \$ 559 | \$ 275 | \$ 227 | \$ 4,496 |
| Midwest | 3,213 | (473) | 2,740 | 646 | 267 | 218 | 4,993 |
| Southern | 3,390 | (412) | 2,978 | 779 | 267 | 265 | 3,493 |
| Western | 3,282 | (446) | 2,836 | 576 | 216 | 271 | 3,961 |
| Wheelabrator | 877 | (121) | 756 | 168 | 67 | 35 | 2,559 |
| Other(a) | <u>1,532</u> | <u>(60)</u> | <u>1,472</u> | <u>(116)</u> | <u>76</u> | <u>217</u> | <u>2,178</u> |
| | 15,409 | (2,031) | 13,378 | 2,612 | 1,168 | 1,233 | 21,680 |
| Corporate and Other(b) | <u>—</u> | <u>—</u> | <u>—</u> | <u>(584)</u> | <u>61</u> | <u>129</u> | <u>1,561</u> |
| Total | <u>\$15,409</u> | <u>\$(2,031)</u> | <u>\$13,378</u> | <u>\$2,028</u> | <u>\$1,229</u> | <u>\$1,362</u> | <u>\$23,241</u> |
| 2010 | | | | | | | |
| Eastern | \$ 2,943 | \$ (508) | \$ 2,435 | \$ 516 | \$ 270 | \$ 201 | \$ 4,272 |
| Midwest | 3,048 | (453) | 2,595 | 533 | 275 | 203 | 4,929 |
| Southern | 3,461 | (403) | 3,058 | 844 | 269 | 230 | 3,256 |
| Western | 3,173 | (438) | 2,735 | 569 | 210 | 223 | 3,715 |
| Wheelabrator | 889 | (125) | 764 | 214 | 64 | 38 | 2,574 |
| Other(a) | <u>963</u> | <u>(35)</u> | <u>928</u> | <u>(135)</u> | <u>50</u> | <u>182</u> | <u>1,744</u> |
| | 14,477 | (1,962) | 12,515 | 2,541 | 1,138 | 1,077 | 20,490 |
| Corporate and Other(b) | <u>—</u> | <u>—</u> | <u>—</u> | <u>(425)</u> | <u>56</u> | <u>90</u> | <u>1,679</u> |
| Total | <u>\$14,477</u> | <u>\$(1,962)</u> | <u>\$12,515</u> | <u>\$2,116</u> | <u>\$1,194</u> | <u>\$1,167</u> | <u>\$22,169</u> |
| 2009 | | | | | | | |
| Eastern | \$ 2,960 | \$ (533) | \$ 2,427 | \$ 483 | \$ 276 | \$ 216 | \$ 4,326 |
| Midwest | 2,855 | (426) | 2,429 | 450 | 261 | 218 | 4,899 |
| Southern | 3,328 | (431) | 2,897 | 768 | 274 | 242 | 3,250 |
| Western | 3,125 | (412) | 2,713 | 521 | 226 | 195 | 3,667 |
| Wheelabrator | 841 | (123) | 718 | 235 | 57 | 11 | 2,266 |
| Other(a) | <u>628</u> | <u>(21)</u> | <u>607</u> | <u>(136)</u> | <u>29</u> | <u>128</u> | <u>1,112</u> |
| | 13,737 | (1,946) | 11,791 | 2,321 | 1,123 | 1,010 | 19,520 |
| Corporate and Other(b) | <u>—</u> | <u>—</u> | <u>—</u> | <u>(434)</u> | <u>43</u> | <u>66</u> | <u>2,281</u> |
| Total | <u>\$13,737</u> | <u>\$(1,946)</u> | <u>\$11,791</u> | <u>\$1,887</u> | <u>\$1,166</u> | <u>\$1,076</u> | <u>\$21,801</u> |

WASTE MANAGEMENT, INC.

NOTES TO CONSOLIDATED FINANCIAL STATEMENTS — (Continued)

- (a) Our “Other” net operating revenues and “Other” income from operations include (i) the effects of those elements of our in-plant services, landfill gas-to-energy operations, and third-party subcontract and administration revenues managed by our Sustainability Services, Renewable Energy and Strategic Accounts organizations, including Oakleaf, respectively, that are not included with the operations of our reportable segments; (ii) our recycling brokerage and electronic recycling services; and (iii) the impacts of investments that we are making in expanded service offerings, such as portable self-storage, fluorescent lamp recycling and healthcare solutions, and in oil and gas producing properties. In addition, our “Other” income from operations reflects the impacts of (i) non-operating entities that provide financial assurance and self-insurance support for the Groups or financing for our Canadian operations; and (ii) certain year-end adjustments recorded in consolidation related to the reportable segments that were not included in the measure of segment profit or loss used to assess their performance for the periods disclosed.
- (b) Corporate operating results reflect the costs incurred for various support services that are not allocated to our five Groups. These support services include, among other things, treasury, legal, information technology, tax, insurance, centralized service center processes, other administrative functions and the maintenance of our closed landfills. Income from operations for “Corporate and other” also includes costs associated with our long-term incentive program and any administrative expenses or revisions to our estimated obligations associated with divested operations.
- (c) Intercompany operating revenues reflect each segment’s total intercompany sales, including intercompany sales within a segment and between segments. Transactions within and between segments are generally made on a basis intended to reflect the market value of the service.
- (d) For those items included in the determination of income from operations, the accounting policies of the segments are the same as those described in Note 3.
- (e) The income from operations provided by our four geographic Groups is generally indicative of the margins provided by our collection, landfill, transfer and recycling businesses. The operating margins provided by our Wheelabrator Group (waste-to-energy facilities and independent power production plants) have historically been higher than the margins provided by our base business generally due to the combined impact of long-term disposal and energy contracts and the disposal demands of the regions in which our facilities are concentrated. However, the revenues and operating results of our Wheelabrator Group have been unfavorably affected by a significant decrease in the rates charged for electricity under our power purchase contracts, which correlate with natural gas prices in the markets where we operate. Exposure to market fluctuations in electricity prices increased for the Wheelabrator Group in 2009 due in large part to the expiration of several long-term energy contracts. Additionally, the Company’s current focus on the expansion of our waste-to-energy business both internationally and domestically has increased Wheelabrator’s costs and expenses, which has negatively affected the comparability of their operating results for the periods presented. From time to time the operating results of our reportable segments are significantly affected by certain transactions or events that management believes are not indicative or representative of our results. Refer to Note 12 and Note 13 for an explanation of certain transactions and events affecting the operating results of our reportable segments.
- (f) Includes non-cash items. Capital expenditures are reported in our reportable segments at the time they are recorded within the segments’ property, plant and equipment balances and, therefore, may include amounts that have been accrued but not yet paid.
- (g) The reconciliation of total assets reported above to “Total assets” in the Consolidated Balance Sheets is as follows (in millions):

| | December 31, | | |
|--|--------------|----------|----------|
| | 2011 | 2010 | 2009 |
| Total assets, as reported above | \$23,241 | \$22,169 | \$21,801 |
| Elimination of intercompany investments and advances | (672) | (693) | (647) |
| Total assets, per Consolidated Balance Sheets | \$22,569 | \$21,476 | \$21,154 |

WASTE MANAGEMENT, INC.

NOTES TO CONSOLIDATED FINANCIAL STATEMENTS — (Continued)

- (h) Goodwill is included within each Group's total assets. As discussed above, for segment reporting purposes, our material recovery facilities and secondary processing facilities are included as a component of their respective geographic Group and our recycling brokerage business and electronics recycling services are included as part of our "Other" operations. As discussed in Note 19, the goodwill associated with our acquisition of Oakleaf, as preliminarily determined, has been assigned to our geographic Groups. The following table shows changes in goodwill during 2010 and 2011 by reportable segment (in millions):

| | <u>Eastern</u> | <u>Midwest</u> | <u>Southern</u> | <u>Western</u> | <u>Wheelabrator</u> | <u>Other</u> | <u>Total</u> |
|--|----------------|----------------|-----------------|----------------|---------------------|--------------|----------------|
| Balance, December 31, 2009 | \$1,500 | \$1,382 | \$679 | \$1,221 | \$788 | \$ 62 | \$5,632 |
| Acquired goodwill | 4 | 17 | 4 | 20 | — | 32 | 77 |
| Divested goodwill, net of assets held-for-sale | — | — | — | — | — | — | — |
| Translation and other adjustments | — | 15 | — | 2 | — | — | 17 |
| Balance, December 31, 2010 | 1,504 | 1,414 | 683 | 1,243 | 788 | 94 | 5,726 |
| Acquired goodwill | 142 | 88 | 142 | 99 | — | 26 | 497 |
| Divested goodwill, net of assets held-for-sale | — | — | — | — | — | — | — |
| Translation and other adjustments | 3 | (1) | 4 | 2 | — | (16) | (8) |
| Balance, December 31, 2011 | <u>\$1,649</u> | <u>\$1,501</u> | <u>\$829</u> | <u>\$1,344</u> | <u>\$788</u> | <u>\$104</u> | <u>\$6,215</u> |

The table below shows the total revenues by principal line of business (in millions):

| | Years Ended December 31, | | |
|------------------------------|---------------------------------|-----------------|-----------------|
| | <u>2011</u> | <u>2010</u> | <u>2009</u> |
| Collection | \$ 8,406 | \$ 8,247 | \$ 7,980 |
| Landfill | 2,611 | 2,540 | 2,547 |
| Transfer | 1,280 | 1,318 | 1,383 |
| Wheelabrator | 877 | 889 | 841 |
| Recycling | 1,580 | 1,169 | 741 |
| Other(a) | 655 | 314 | 245 |
| Intercompany(b) | (2,031) | (1,962) | (1,946) |
| Operating revenues | <u>\$13,378</u> | <u>\$12,515</u> | <u>\$11,791</u> |

- (a) The "Other" line of business includes Oakleaf, landfill gas-to-energy operations, Port-O-Let® services, portable self-storage, fluorescent lamp recycling, oil and gas producing properties and healthcare solutions operations.
- (b) Intercompany revenues between lines of business are eliminated within the Consolidated Financial Statements included herein.

Net operating revenues relating to operations in the United States and Puerto Rico, as well as Canada are as follows (in millions):

| | Years Ended December 31, | | |
|---|---------------------------------|-----------------|-----------------|
| | <u>2011</u> | <u>2010</u> | <u>2009</u> |
| United States and Puerto Rico | \$12,578 | \$11,784 | \$11,137 |
| Canada | 800 | 731 | 654 |
| Total | <u>\$13,378</u> | <u>\$12,515</u> | <u>\$11,791</u> |

WASTE MANAGEMENT, INC.

NOTES TO CONSOLIDATED FINANCIAL STATEMENTS — (Continued)

Property and equipment (net) relating to operations in the United States and Puerto Rico, as well as Canada are as follows (in millions):

| | December 31, | | |
|-------------------------------------|--------------|----------|----------|
| | 2011 | 2010 | 2009 |
| United States and Puerto Rico | \$10,948 | \$10,558 | \$10,251 |
| Canada | 1,294 | 1,310 | 1,290 |
| Total | \$12,242 | \$11,868 | \$11,541 |

22. Quarterly Financial Data (Unaudited)

The following table summarizes the unaudited quarterly results of operations for 2011 and 2010 (in millions, except per share amounts):

| | First Quarter | Second Quarter | Third Quarter | Fourth Quarter |
|--|------------------|-------------------|------------------|-------------------|
| 2011 | | | | |
| Operating revenues | \$3,103 | \$3,347 | \$3,522 | \$3,406 |
| Income from operations | 427 | 506 | 543 | 552 |
| Consolidated net income | 196 | 250 | 285 | 278 |
| Net income attributable to Waste Management, Inc. | 186 | 237 | 272 | 266 |
| Basic earnings per common share | 0.39 | 0.50 | 0.58 | 0.58 |
| Diluted earnings per common share | 0.39 | 0.50 | 0.58 | 0.58 |
| 2010 | | | | |
| Operating revenues | \$2,935 | \$3,158 | \$3,235 | \$3,187 |
| Income from operations | 412 | 586 | 544 | 574 |
| Consolidated net income | 192 | 258 | 258 | 294 |
| Net income attributable to Waste Management, Inc. | 182 | 246 | 244 | 281 |
| Basic earnings per common share | 0.37 | 0.51 | 0.51 | 0.59 |
| Diluted earnings per common share | 0.37 | 0.51 | 0.51 | 0.59 |

Basic and diluted earnings per common share for each of the quarters presented above is based on the respective weighted average number of common and dilutive potential common shares outstanding for each quarter and the sum of the quarters may not necessarily be equal to the full year basic and diluted earnings per common share amounts.

Our operating revenues normally tend to be somewhat higher in the summer months, primarily due to the traditional seasonal increase in the volume of construction and demolition waste. Historically, the volumes of industrial and residential waste in certain regions in which we operate have tended to increase during the summer months. Our second and third quarter revenues and results of operations typically reflect these seasonal trends. Additionally, from time to time, our operating results are significantly affected by certain transactions or events that management believes are not indicative or representative of our results. The following significant items have affected the comparison of our operating results during the periods indicated:

Third Quarter 2011

- Income from operations was negatively impacted by the recognition of pre-tax restructuring charges, excluding charges recognized in the operating results of Oakleaf, of \$14 million related to our cost savings programs. These charges were primarily related to employee severance and benefit costs and negatively affected our diluted earnings per share by \$0.02.

WASTE MANAGEMENT, INC.

NOTES TO CONSOLIDATED FINANCIAL STATEMENTS — (Continued)

- Income from operations was negatively impacted by the recognition of net non-cash, pre-tax charges of \$8 million arising from the accounting effect of lower ten-year Treasury rates, which are used to discount remediation reserves and related recovery assets at our landfills, offset in part by the favorable impact from a revision to an environmental remediation liability at a closed landfill. The net charges had a negative impact of \$0.01 on our diluted earnings per share.
- Income from operations was negatively impacted by a reduction in pre-tax earnings of approximately \$6 million related to the Oakleaf acquisition, which includes the operating results of Oakleaf and related interest expense and integration costs. These items negatively affected our diluted earnings per share by \$0.01.
- Income from operations was negatively impacted by the recognition of non-cash, pre-tax charges of \$6 million related to impairments at two of our medical waste services facilities. The impairment charges had a negative impact of \$0.01 on our diluted earnings per share.
- Our “Provision for income taxes” for the quarter was reduced by \$10 million as a result of the finalization of our 2010 tax returns and tax audit settlements, which positively affected our diluted earnings per share by \$0.02.

Fourth Quarter 2011

- Income from operations was negatively impacted by \$24 million of “Selling, general and administrative” expense related to a litigation loss in our Western Group, which had a negative impact of \$0.03 on our diluted earnings per share.
- Income from operations was positively impacted by a \$20 million decrease to “Depreciation and amortization” expense for adjustments associated with changes in our expectations for the timing and cost of future final capping, closure and post-closure of fully utilized airspace. This decrease had a positive impact of approximately \$0.03 on our diluted earnings per share.
- Our “Provision for income taxes” for the quarter was reduced by \$7 million as a result of (i) the recognition of a benefit of \$4 million due to tax audit settlements; and (ii) the realization of state net operating loss and credit carry-forwards of \$3 million. This decrease in taxes positively affected the quarter’s diluted earnings per share by \$0.01.

First Quarter 2010

- Income from operations was negatively affected by the recognition of a \$28 million charge to “Operating” expenses incurred by our Midwest Group as a result of bargaining unit employees in Michigan and Ohio agreeing to our proposal to withdraw them from an underfunded multiemployer pension plan. This charge reduced diluted earnings per share for the quarter by \$0.04.
- The severe winter weather experienced in early 2010 reduced our revenues and increased our overtime and landfill operating costs, causing an estimated decrease in our diluted earnings per share of \$0.02.

Second Quarter 2010

- Income from operations was positively affected by the recognition of a pre-tax cash benefit of \$77 million due to the settlement of a lawsuit related to the abandonment of revenue management software, which had a favorable impact of \$0.10 on our diluted earnings per share.
- Income from operations was negatively affected by (i) the recognition of a pre-tax non-cash charge of \$39 million related to increases in our environmental remediation reserves principally related to two closed landfill sites; and (ii) the recognition of an \$8 million unfavorable adjustment to “Operating” expenses due to a decrease from 3.75% to 3.0% in the discount rate used to estimate the present value of our environmental remediation obligations and recovery assets. These items decreased the quarter’s “Net Income attributable to Waste Management, Inc.” by \$30 million, or \$0.06 per diluted share.

WASTE MANAGEMENT, INC.

NOTES TO CONSOLIDATED FINANCIAL STATEMENTS — (Continued)

- Our “Provision for income taxes” for the quarter was increased by the recognition of a tax charge of \$37 million principally related to refinements in estimates of our deferred state income taxes, which had a negative impact of \$0.08 on our diluted earnings per share.

Third Quarter 2010

- Income from operations was negatively affected by (i) the recognition of pre-tax, non-cash charges aggregating \$16 million related to remediation and closure costs at five closed sites; and (ii) the recognition of a \$6 million unfavorable adjustment to “Operating” expenses due to a decrease from 3.0% to 2.5% in the discount rate used to estimate the present value of our environmental remediation obligations and recovery assets. These items decreased the quarter’s “Net Income attributable to Waste Management, Inc.” by \$14 million, or \$0.03 per diluted share.
- Our “Provision for income taxes” for the quarter was increased by the recognition of net tax charges of \$4 million due to adjustments relating to the finalization of our 2009 tax returns, partially offset by favorable tax audit settlements, which, combined, had a negative impact of \$0.01 on our diluted earnings per share.

Fourth Quarter 2010

- Income from operations was positively affected by (i) a \$23 million decrease to “Depreciation and amortization” expense for adjustments associated with changes in our expectations for the timing and cost of future final capping, closure and post-closure of fully utilized airspace; and (ii) the recognition of a \$12 million favorable adjustment to “Operating” expenses due to an increase from 2.5% to 3.5% in the discount rate used to estimate the present value of our environmental remediation obligations and recovery assets. These items increased the quarter’s “Net Income attributable to Waste Management, Inc.” by \$22 million, or \$0.05 per diluted share.
- Income from operations was negatively affected by the recognition of pre-tax litigation charges of \$31 million, which had an unfavorable impact of \$0.04 on our diluted earnings per share.
- Our “Provision for income taxes” for the quarter was reduced by \$9 million as a result of (i) the recognition of a benefit of \$6 million due to tax audit settlements; and (ii) the realization of state net operating loss and credit carry-forwards of \$3 million. This decrease in taxes positively affected the quarter’s diluted earnings per common share by \$0.02.

23. Condensed Consolidating Financial Statements

WM Holdings has fully and unconditionally guaranteed all of WM’s senior indebtedness. WM has fully and unconditionally guaranteed all of WM Holdings’ senior indebtedness. None of WM’s other subsidiaries have guaranteed any of WM’s or WM Holdings’ debt. As a result of these guarantee arrangements, we are required to present the following condensed consolidating financial information (in millions):

WASTE MANAGEMENT, INC.

NOTES TO CONSOLIDATED FINANCIAL STATEMENTS — (Continued)

CONDENSED CONSOLIDATING BALANCE SHEETS

December 31, 2011

| | <u>WM</u> | <u>WM Holdings</u> | <u>Non-Guarantor Subsidiaries</u> | <u>Eliminations</u> | <u>Consolidated</u> |
|--|-----------------|------------------------|---------------------------------------|---------------------|---------------------|
| ASSETS | | | | | |
| Current assets: | | | | | |
| Cash and cash equivalents | \$ 119 | \$ — | \$ 139 | \$ — | \$ 258 |
| Other current assets | <u>6</u> | <u>—</u> | <u>2,115</u> | <u>—</u> | <u>2,121</u> |
| | 125 | — | 2,254 | — | 2,379 |
| Property and equipment, net | — | — | 12,242 | — | 12,242 |
| Investments in and advances to affiliates . . . | 12,006 | 14,905 | 3,036 | (29,947) | — |
| Other assets | <u>120</u> | <u>12</u> | <u>7,816</u> | <u>—</u> | <u>7,948</u> |
| Total assets | <u>\$12,251</u> | <u>\$14,917</u> | <u>\$25,348</u> | <u>\$(29,947)</u> | <u>\$22,569</u> |
| LIABILITIES AND EQUITY | | | | | |
| Current liabilities: | | | | | |
| Current portion of long-term debt | \$ 298 | \$ — | \$ 333 | \$ — | \$ 631 |
| Accounts payable and other current liabilities | <u>124</u> | <u>13</u> | <u>2,300</u> | <u>—</u> | <u>2,437</u> |
| | 422 | 13 | 2,633 | — | 3,068 |
| Long-term debt, less current portion | 5,727 | 449 | 2,949 | — | 9,125 |
| Other liabilities | <u>32</u> | <u>—</u> | <u>3,954</u> | <u>—</u> | <u>3,986</u> |
| Total liabilities | 6,181 | 462 | 9,536 | — | 16,179 |
| Equity: | | | | | |
| Stockholders' equity | 6,070 | 14,455 | 15,492 | (29,947) | 6,070 |
| Noncontrolling interests | <u>—</u> | <u>—</u> | <u>320</u> | <u>—</u> | <u>320</u> |
| | <u>6,070</u> | <u>14,455</u> | <u>15,812</u> | <u>(29,947)</u> | <u>6,390</u> |
| Total liabilities and equity | <u>\$12,251</u> | <u>\$14,917</u> | <u>\$25,348</u> | <u>\$(29,947)</u> | <u>\$22,569</u> |

WASTE MANAGEMENT, INC.

NOTES TO CONSOLIDATED FINANCIAL STATEMENTS — (Continued)

CONDENSED CONSOLIDATING BALANCE SHEETS (Continued)

December 31, 2010

| | <u>WM</u> | <u>WM Holdings</u> | <u>Non-Guarantor Subsidiaries</u> | <u>Eliminations</u> | <u>Consolidated</u> |
|--|-----------------|------------------------|---------------------------------------|---------------------|---------------------|
| ASSETS | | | | | |
| Current assets: | | | | | |
| Cash and cash equivalents | \$ 465 | \$ — | \$ 74 | \$ — | \$ 539 |
| Other current assets | <u>4</u> | <u>1</u> | <u>1,938</u> | <u>—</u> | <u>1,943</u> |
| | 469 | 1 | 2,012 | — | 2,482 |
| Property and equipment, net | — | — | 11,868 | — | 11,868 |
| Investments in and advances to affiliates . . . | 10,757 | 13,885 | 2,970 | (27,612) | — |
| Other assets | <u>91</u> | <u>12</u> | <u>7,023</u> | <u>—</u> | <u>7,126</u> |
| Total assets | <u>\$11,317</u> | <u>\$13,898</u> | <u>\$23,873</u> | <u>\$(27,612)</u> | <u>\$21,476</u> |
| LIABILITIES AND EQUITY | | | | | |
| Current liabilities: | | | | | |
| Current portion of long-term debt | \$ — | \$ 1 | \$ 232 | \$ — | \$ 233 |
| Accounts payable and other current liabilities | <u>93</u> | <u>17</u> | <u>2,142</u> | <u>—</u> | <u>2,252</u> |
| | 93 | 18 | 2,374 | — | 2,485 |
| Long-term debt, less current portion | 4,951 | 596 | 3,127 | — | 8,674 |
| Other liabilities | <u>13</u> | <u>—</u> | <u>3,713</u> | <u>—</u> | <u>3,726</u> |
| Total liabilities | 5,057 | 614 | 9,214 | — | 14,885 |
| Equity: | | | | | |
| Stockholders' equity | 6,260 | 13,284 | 14,328 | (27,612) | 6,260 |
| Noncontrolling interests | <u>—</u> | <u>—</u> | <u>331</u> | <u>—</u> | <u>331</u> |
| | <u>6,260</u> | <u>13,284</u> | <u>14,659</u> | <u>(27,612)</u> | <u>6,591</u> |
| Total liabilities and equity | <u>\$11,317</u> | <u>\$13,898</u> | <u>\$23,873</u> | <u>\$(27,612)</u> | <u>\$21,476</u> |

WASTE MANAGEMENT, INC.

NOTES TO CONSOLIDATED FINANCIAL STATEMENTS — (Continued)

CONDENSED CONSOLIDATING STATEMENTS OF OPERATIONS

| | <u>WM</u> | <u>WM Holdings</u> | <u>Non-Guarantor Subsidiaries</u> | <u>Eliminations</u> | <u>Consolidated</u> |
|---|---------------|------------------------|---------------------------------------|---------------------|---------------------|
| Year Ended December 31, 2011 | | | | | |
| Operating revenues | \$ — | \$ — | \$13,378 | \$ — | \$13,378 |
| Costs and expenses | <u>—</u> | <u>—</u> | <u>11,350</u> | <u>—</u> | <u>11,350</u> |
| Income from operations | <u>—</u> | <u>—</u> | <u>2,028</u> | <u>—</u> | <u>2,028</u> |
| Other income (expense): | | | | | |
| Interest income (expense) | (342) | (33) | (98) | — | (473) |
| Equity in earnings of subsidiaries, net of taxes | 1,168 | 1,188 | — | (2,356) | — |
| Equity in net losses of unconsolidated entities and other, net | <u>—</u> | <u>—</u> | <u>(35)</u> | <u>—</u> | <u>(35)</u> |
| | <u>826</u> | <u>1,155</u> | <u>(133)</u> | <u>(2,356)</u> | <u>(508)</u> |
| Income before income taxes | 826 | 1,155 | 1,895 | (2,356) | 1,520 |
| Provision for (benefit from) income taxes ... | <u>(135)</u> | <u>(13)</u> | <u>659</u> | <u>—</u> | <u>511</u> |
| Consolidated net income | 961 | 1,168 | 1,236 | (2,356) | 1,009 |
| Less: Net income attributable to noncontrolling interests | <u>—</u> | <u>—</u> | <u>48</u> | <u>—</u> | <u>48</u> |
| Net income attributable to Waste Management, Inc. | <u>\$ 961</u> | <u>\$1,168</u> | <u>\$ 1,188</u> | <u>\$(2,356)</u> | <u>\$ 961</u> |
| Year Ended December 31, 2010 | | | | | |
| Operating revenues | \$ — | \$ — | \$12,515 | \$ — | \$12,515 |
| Costs and expenses | <u>—</u> | <u>—</u> | <u>10,399</u> | <u>—</u> | <u>10,399</u> |
| Income from operations | <u>—</u> | <u>—</u> | <u>2,116</u> | <u>—</u> | <u>2,116</u> |
| Other income (expense): | | | | | |
| Interest income (expense) | (324) | (38) | (107) | — | (469) |
| Equity in earnings of subsidiaries, net of taxes | 1,149 | 1,172 | — | (2,321) | — |
| Equity in net losses of unconsolidated entities and other, net | <u>—</u> | <u>—</u> | <u>(16)</u> | <u>—</u> | <u>(16)</u> |
| | <u>825</u> | <u>1,134</u> | <u>(123)</u> | <u>(2,321)</u> | <u>(485)</u> |
| Income before income taxes | 825 | 1,134 | 1,993 | (2,321) | 1,631 |
| Provision for (benefit from) income taxes ... | <u>(128)</u> | <u>(15)</u> | <u>772</u> | <u>—</u> | <u>629</u> |
| Consolidated net income | 953 | 1,149 | 1,221 | (2,321) | 1,002 |
| Less: Net income attributable to noncontrolling interests | <u>—</u> | <u>—</u> | <u>49</u> | <u>—</u> | <u>49</u> |
| Net income attributable to Waste Management, Inc. | <u>\$ 953</u> | <u>\$1,149</u> | <u>\$ 1,172</u> | <u>\$(2,321)</u> | <u>\$ 953</u> |

WASTE MANAGEMENT, INC.

NOTES TO CONSOLIDATED FINANCIAL STATEMENTS — (Continued)

CONDENSED CONSOLIDATING STATEMENTS OF OPERATIONS (Continued)

| | WM | WM Holdings | Non-Guarantor Subsidiaries | Eliminations | Consolidated |
|---|---------------|------------------------|---------------------------------------|---------------------|---------------------|
| Year Ended December 31, 2009 | | | | | |
| Operating revenues | \$ — | \$ — | \$11,791 | \$ — | \$11,791 |
| Costs and expenses | <u>—</u> | <u>—</u> | <u>9,904</u> | <u>—</u> | <u>9,904</u> |
| Income from operations | <u>—</u> | <u>—</u> | <u>1,887</u> | <u>—</u> | <u>1,887</u> |
| Other income (expense): | | | | | |
| Interest income (expense) | (268) | (41) | (104) | — | (413) |
| Equity in earnings of subsidiaries, net of taxes | 1,157 | 1,182 | — | (2,339) | — |
| Equity in net losses of unconsolidated entities and other, net | <u>—</u> | <u>—</u> | <u>(1)</u> | <u>—</u> | <u>(1)</u> |
| | <u>889</u> | <u>1,141</u> | <u>(105)</u> | <u>(2,339)</u> | <u>(414)</u> |
| Income before income taxes | 889 | 1,141 | 1,782 | (2,339) | 1,473 |
| Provision for (benefit from) income taxes ... | <u>(105)</u> | <u>(16)</u> | <u>534</u> | <u>—</u> | <u>413</u> |
| Consolidated net income | 994 | 1,157 | 1,248 | (2,339) | 1,060 |
| Less: Net income attributable to noncontrolling interests | <u>—</u> | <u>—</u> | <u>66</u> | <u>—</u> | <u>66</u> |
| Net income attributable to Waste Management, Inc. | <u>\$ 994</u> | <u>\$1,157</u> | <u>\$ 1,182</u> | <u>\$(2,339)</u> | <u>\$ 994</u> |

WASTE MANAGEMENT, INC.

NOTES TO CONSOLIDATED FINANCIAL STATEMENTS — (Continued)

CONDENSED CONSOLIDATING STATEMENTS OF CASH FLOWS

| | <u>WM</u> | <u>WM Holdings</u> | <u>Non-Guarantor Subsidiaries</u> | <u>Eliminations</u> | <u>Consolidated</u> |
|---|---------------|------------------------|---------------------------------------|---------------------|---------------------|
| Year Ended December 31, 2011 | | | | | |
| Cash flows from operating activities: | | | | | |
| Consolidated net income | \$ 961 | \$ 1,168 | \$ 1,236 | \$(2,356) | \$ 1,009 |
| Equity in earnings of subsidiaries, net of taxes | (1,168) | (1,188) | — | 2,356 | — |
| Other adjustments | <u>12</u> | <u>(3)</u> | <u>1,451</u> | <u>—</u> | <u>1,460</u> |
| Net cash provided by (used in) operating activities | <u>(195)</u> | <u>(23)</u> | <u>2,687</u> | <u>—</u> | <u>2,469</u> |
| Cash flows from investing activities: | | | | | |
| Acquisition of businesses, net of cash acquired | — | — | (867) | — | (867) |
| Capital expenditures | — | — | (1,324) | — | (1,324) |
| Proceeds from divestitures of businesses (net of cash divested) and other sales of assets | — | — | 36 | — | 36 |
| Net receipts from restricted trust and escrow accounts and other, net | <u>(5)</u> | <u>—</u> | <u>(25)</u> | <u>—</u> | <u>(30)</u> |
| Net cash provided by (used in) investing activities | <u>(5)</u> | <u>—</u> | <u>(2,180)</u> | <u>—</u> | <u>(2,185)</u> |
| Cash flows from financing activities: | | | | | |
| New borrowings | 1,043 | — | 158 | — | 1,201 |
| Debt repayments | — | (147) | (356) | — | (503) |
| Common stock repurchases | (575) | — | — | — | (575) |
| Cash dividends | (637) | — | — | — | (637) |
| Exercise of common stock options | 45 | — | — | — | 45 |
| Distributions paid to noncontrolling interests and other | (10) | — | (87) | — | (97) |
| (Increase) decrease in intercompany and investments, net | <u>(12)</u> | <u>170</u> | <u>(158)</u> | <u>—</u> | <u>—</u> |
| Net cash provided by (used in) financing activities | <u>(146)</u> | <u>23</u> | <u>(443)</u> | <u>—</u> | <u>(566)</u> |
| Effect of exchange rate changes on cash and cash equivalents | <u>—</u> | <u>—</u> | <u>1</u> | <u>—</u> | <u>1</u> |
| Increase (decrease) in cash and cash equivalents | (346) | — | 65 | — | (281) |
| Cash and cash equivalents at beginning of period | <u>465</u> | <u>—</u> | <u>74</u> | <u>—</u> | <u>539</u> |
| Cash and cash equivalents at end of period | <u>\$ 119</u> | <u>\$ —</u> | <u>\$ 139</u> | <u>\$ —</u> | <u>\$ 258</u> |

WASTE MANAGEMENT, INC.

NOTES TO CONSOLIDATED FINANCIAL STATEMENTS — (Continued)

CONDENSED CONSOLIDATING STATEMENTS OF CASH FLOWS (Continued)

| | <u>WM</u> | <u>WM Holdings</u> | <u>Non-Guarantor Subsidiaries</u> | <u>Eliminations</u> | <u>Consolidated</u> |
|---|---------------|------------------------|---------------------------------------|---------------------|---------------------|
| Year Ended December 31, 2010 | | | | | |
| Cash flows from operating activities: | | | | | |
| Consolidated net income | \$ 953 | \$ 1,149 | \$ 1,221 | \$(2,321) | \$ 1,002 |
| Equity in earnings of subsidiaries, net of taxes | (1,149) | (1,172) | — | 2,321 | — |
| Other adjustments | <u>44</u> | <u>(3)</u> | <u>1,232</u> | <u>—</u> | <u>1,273</u> |
| Net cash provided by (used in) operating activities | <u>(152)</u> | <u>(26)</u> | <u>2,453</u> | <u>—</u> | <u>2,275</u> |
| Cash flows from investing activities: | | | | | |
| Acquisition of businesses, net of cash acquired | — | — | (407) | — | (407) |
| Capital expenditures | — | — | (1,104) | — | (1,104) |
| Proceeds from divestitures of businesses (net of cash divested) and other sales of assets | — | — | 44 | — | 44 |
| Net receipts from restricted trust and escrow accounts and other, net | <u>(5)</u> | <u>—</u> | <u>(134)</u> | <u>—</u> | <u>(139)</u> |
| Net cash provided by (used in) investing activities | <u>(5)</u> | <u>—</u> | <u>(1,601)</u> | <u>—</u> | <u>(1,606)</u> |
| Cash flows from financing activities: | | | | | |
| New borrowings | 592 | — | 316 | — | 908 |
| Debt repayments | (617) | (35) | (460) | — | (1,112) |
| Common stock repurchases | (501) | — | — | — | (501) |
| Cash dividends | (604) | — | — | — | (604) |
| Exercise of common stock options | 54 | — | — | — | 54 |
| Distributions paid to noncontrolling interests and other | (6) | — | (12) | — | (18) |
| (Increase) decrease in intercompany and investments, net | <u>611</u> | <u>61</u> | <u>(672)</u> | <u>—</u> | <u>—</u> |
| Net cash provided by (used in) financing activities | <u>(471)</u> | <u>26</u> | <u>(828)</u> | <u>—</u> | <u>(1,273)</u> |
| Effect of exchange rate changes on cash and cash equivalents | <u>—</u> | <u>—</u> | <u>3</u> | <u>—</u> | <u>3</u> |
| Increase (decrease) in cash and cash equivalents | (628) | — | 27 | — | (601) |
| Cash and cash equivalents at beginning of period | <u>1,093</u> | <u>—</u> | <u>47</u> | <u>—</u> | <u>1,140</u> |
| Cash and cash equivalents at end of period | <u>\$ 465</u> | <u>\$ —</u> | <u>\$ 74</u> | <u>\$ —</u> | <u>\$ 539</u> |

WASTE MANAGEMENT, INC.

NOTES TO CONSOLIDATED FINANCIAL STATEMENTS — (Continued)

CONDENSED CONSOLIDATING STATEMENTS OF CASH FLOWS (Continued)

| | <u>WM</u> | <u>WM Holdings</u> | <u>Non-Guarantor Subsidiaries</u> | <u>Eliminations</u> | <u>Consolidated</u> |
|--|-----------------|------------------------|---------------------------------------|---------------------|---------------------|
| Year Ended December 31, 2009 | | | | | |
| Cash flows from operating activities: | | | | | |
| Consolidated net income | \$ 994 | \$ 1,157 | \$ 1,248 | \$(2,339) | \$ 1,060 |
| Equity in earnings of subsidiaries, net of taxes | (1,157) | (1,182) | — | 2,339 | — |
| Other adjustments | <u>26</u> | <u>(3)</u> | <u>1,279</u> | <u>—</u> | <u>1,302</u> |
| Net cash provided by (used in) operating activities | <u>(137)</u> | <u>(28)</u> | <u>2,527</u> | <u>—</u> | <u>2,362</u> |
| Cash flows from investing activities: | | | | | |
| Acquisitions of businesses, net of cash acquired | — | — | (281) | — | (281) |
| Capital expenditures | — | — | (1,179) | — | (1,179) |
| Proceeds from divestitures of businesses (net of cash divested) and other sales of assets | — | — | 28 | — | 28 |
| Net receipts from restricted trust and escrow accounts and other, net | <u>—</u> | <u>—</u> | <u>182</u> | <u>—</u> | <u>182</u> |
| Net cash provided by (used in) investing activities | <u>—</u> | <u>—</u> | <u>(1,250)</u> | <u>—</u> | <u>(1,250)</u> |
| Cash flows from financing activities: | | | | | |
| New borrowings | 1,385 | — | 364 | — | 1,749 |
| Debt repayments | (810) | — | (525) | — | (1,335) |
| Common stock repurchases | (226) | — | — | — | (226) |
| Cash dividends | (569) | — | — | — | (569) |
| Exercise of common stock options | 20 | — | — | — | 20 |
| Distributions paid to noncontrolling interests and other | 3 | — | (99) | — | (96) |
| (Increase) decrease in intercompany and investments, net | <u>977</u> | <u>28</u> | <u>(1,005)</u> | <u>—</u> | <u>—</u> |
| Net cash provided by (used in) financing activities | <u>780</u> | <u>28</u> | <u>(1,265)</u> | <u>—</u> | <u>(457)</u> |
| Effect of exchange rate changes on cash and cash equivalents | <u>—</u> | <u>—</u> | <u>5</u> | <u>—</u> | <u>5</u> |
| Increase (decrease) in cash and cash equivalents | 643 | — | 17 | — | 660 |
| Cash and cash equivalents at beginning of period | <u>450</u> | <u>—</u> | <u>30</u> | <u>—</u> | <u>480</u> |
| Cash and cash equivalents at end of period | <u>\$ 1,093</u> | <u>\$ —</u> | <u>\$ 47</u> | <u>\$ —</u> | <u>\$ 1,140</u> |

WASTE MANAGEMENT, INC.

NOTES TO CONSOLIDATED FINANCIAL STATEMENTS — (Continued)

CONDENSED CONSOLIDATING STATEMENTS OF CASH FLOWS (Continued)

24. New Accounting Pronouncements

Fair Value Measurements — In May 2011, the FASB amended authoritative guidance associated with fair value measurements. This amended guidance defines certain requirements for measuring fair value and for disclosing information about fair value measurements in accordance with U.S. generally accepted accounting principles. The amendments to authoritative guidance associated with fair value measurements were effective for the Company on January 1, 2012 and are to be applied prospectively. We do not expect that the adoption of this guidance will have a material impact on our consolidated financial statements.

Item 9. *Changes in and Disagreements With Accountants on Accounting and Financial Disclosure.*

None.

Item 9A. *Controls and Procedures.*

Effectiveness of Controls and Procedures

Our management, with the participation of our principal executive and financial officers, has evaluated the effectiveness of our disclosure controls and procedures in ensuring that the information required to be disclosed in reports that we file or submit under the Securities Exchange Act of 1934, as amended, is recorded, processed, summarized and reported within the time periods specified in the SEC's rules and forms, including ensuring that such information is accumulated and communicated to management (including the principal executive and financial officers) as appropriate to allow timely decisions regarding required disclosure. Based on such evaluation, our principal executive and financial officers have concluded that such disclosure controls and procedures were effective as of December 31, 2011 (the end of the period covered by this Annual Report on Form 10-K).

Management's Report on Internal Control Over Financial Reporting

Management's report on our internal control over financial reporting can be found in Item 8, *Financial Statements and Supplementary Data*, of this report. Ernst & Young LLP, an independent registered public accounting firm, has audited the effectiveness of our internal control over financial reporting as of December 31, 2011 as stated in their report, which appears in Item 8 of this report.

Changes in Internal Control over Financial Reporting

Management, together with our principal executive and financial officers, evaluated the changes in our internal control over financial reporting during the quarter ended December 31, 2011. We determined that there were no changes in our internal control over financial reporting during the quarter ended December 31, 2011 that have materially affected, or are reasonably likely to materially affect, our internal control over financial reporting.

Item 9B. *Other Information.*

None.

PART III

Item 10. *Directors, Executive Officers and Corporate Governance.*

The information required by this Item is incorporated by reference to the sections entitled "Board of Directors," "Section 16(a) Beneficial Ownership Reporting Compliance," and "Executive Officers," in the Company's definitive Proxy Statement for its 2012 Annual Meeting of Stockholders (the "Proxy Statement"), to be held May 10, 2012. The Proxy Statement will be filed with the SEC within 120 days of the end of our fiscal year.

We have adopted a code of ethics that applies to our CEO, principal financial officer and Chief Accounting Officer, as well as other officers, directors and employees of the Company. The code of ethics, entitled "Code of Conduct," is posted on our website at <http://www.wm.com> under the section "Corporate Governance" within the "Investor Relations" tab.

Item 11. *Executive Compensation.*

The information required by this Item is incorporated herein by reference to the sections entitled “Board of Directors — Non-Employee Director Compensation,” “— Compensation Committee Report,” “— Compensation Committee Interlocks and Insider Participation,” “Executive Compensation — Compensation Discussion and Analysis” and “— Executive Compensation Tables” in the Proxy Statement.

Item 12. *Security Ownership of Certain Beneficial Owners and Management and Related Stockholder Matters.*

The information required by this Item is incorporated herein by reference to the sections entitled “Equity Compensation Plan Table,” “Director Nominee and Officer Stock Ownership,” and “Persons Owning More than 5% of Waste Management Common Stock” in the Proxy Statement.

Item 13. *Certain Relationships and Related Transactions, and Director Independence.*

The information required by this Item is incorporated herein by reference to the sections entitled “Board of Directors — Related Party Transactions” and “— Independence of Board Members” in the Proxy Statement.

Item 14. *Principal Accounting Fees and Services.*

The information required by this Item is incorporated herein by reference to the section entitled “Ratification of Independent Registered Public Accounting Firm — Independent Registered Public Accounting Firm Fee Information” in the Proxy Statement.

PART IV

Item 15. *Exhibits, Financial Statement Schedules*

(a) (1) Consolidated Financial Statements:

Reports of Independent Registered Public Accounting Firm
Consolidated Balance Sheets as of December 31, 2011 and 2010
Consolidated Statements of Operations for the years ended December 31, 2011, 2010 and 2009
Consolidated Statements of Cash Flows for the years ended December 31, 2011, 2010 and 2009
Consolidated Statements of Changes in Equity for the years ended December 31, 2011, 2010 and 2009
Notes to Consolidated Financial Statements

(a) (2) *Consolidated Financial Statement Schedules:*

Schedule II — Valuation and Qualifying Accounts

All other schedules have been omitted because the required information is not significant or is included in the financial statements or notes thereto, or is not applicable.

(b) *Exhibits:*

The exhibit list required by this Item is incorporated by reference to the Exhibit Index filed as part of this report.

SIGNATURES

Pursuant to the requirements of Section 13 or 15(d) of the Securities Exchange Act of 1934, the Registrant has duly caused this Report to be signed on its behalf by the undersigned, thereunto duly authorized.

WASTE MANAGEMENT, INC.

By: /s/ DAVID P. STEINER
David P. Steiner
President, Chief Executive Officer and Director

Date: February 16, 2012

Pursuant to the requirements of the Securities Exchange Act of 1934, this report has been signed below by the following persons on behalf of the Registrant and in the capacities and on the dates indicated.

| <u>Signature</u> | <u>Title</u> | <u>Date</u> |
|---|---|-------------------|
| <u> /s/ DAVID P. STEINER </u> David P. Steiner | President, Chief Executive Officer and Director (Principal Executive Officer) | February 16, 2012 |
| <u> /s/ STEVEN C. PRESTON </u> Steven C. Preston | Executive Vice President — Finance, Recycling & Energy Services (Principal Financial Officer) | February 16, 2012 |
| <u> /s/ GREG A. ROBERTSON </u> Greg A. Robertson | Vice President and Chief Accounting Officer (Principal Accounting Officer) | February 16, 2012 |
| <u> /s/ BRADBURY H. ANDERSON </u> Bradbury H. Anderson | Director | February 16, 2012 |
| <u> /s/ PASTORA SAN JUAN CAFFERTY </u> Pastora San Juan Cafferty | Director | February 16, 2012 |
| <u> /s/ FRANK M. CLARK </u> Frank M. Clark | Director | February 16, 2012 |
| <u> /s/ PATRICK W. GROSS </u> Patrick W. Gross | Director | February 16, 2012 |
| <u> /s/ JOHN C. POPE </u> John C. Pope | Director | February 16, 2012 |
| <u> /s/ W. ROBERT REUM </u> W. Robert Reum | Chairman of the Board and Director | February 16, 2012 |
| <u> /s/ STEVEN G. ROTHMEIER </u> Steven G. Rothmeier | Director | February 16, 2012 |
| <u> /s/ THOMAS H. WEIDEMEYER </u> Thomas H. Weidemeyer | Director | February 16, 2012 |

REPORT OF INDEPENDENT REGISTERED PUBLIC ACCOUNTING FIRM

The Board of Directors and Stockholders of Waste Management, Inc.

We have audited the consolidated financial statements of Waste Management, Inc. as of December 31, 2011 and 2010, and for each of the three years in the period ended December 31, 2011, and have issued our report thereon dated February 16, 2012 (included elsewhere in this Form 10-K). Our audits also included the financial statement schedule listed in Item 15(a)(2) of this Form 10-K. This schedule is the responsibility of the Company's management. Our responsibility is to express an opinion based on our audits.

In our opinion, the financial statement schedule referred to above, when considered in relation to the basic financial statements taken as a whole, presents fairly in all material respects the information set forth therein.

ERNST & YOUNG LLP

Houston, Texas
February 16, 2012

WASTE MANAGEMENT, INC.

SCHEDULE II — VALUATION AND QUALIFYING ACCOUNTS
(In Millions)

| | <u>Balance Beginning of Year</u> | <u>Charged (Credited) to Income</u> | <u>Accounts Written Off/Use of Reserve</u> | <u>Other(a)</u> | <u>Balance End of Year</u> |
|---|--|---|--|-----------------|------------------------------------|
| 2009 — Reserves for doubtful accounts(b) | \$39 | \$48 | \$(57) | \$ 2 | \$32 |
| 2010 — Reserves for doubtful accounts(b) | \$32 | \$41 | \$(47) | \$ 1 | \$27 |
| 2011 — Reserves for doubtful accounts(b) | \$27 | \$44 | \$(42) | \$— | \$29 |
| 2009 — Merger and restructuring accruals(c) | \$ 2 | \$50 | \$(42) | \$— | \$10 |
| 2010 — Merger and restructuring accruals(c) | \$10 | \$(2) | \$ (5) | \$— | \$ 3 |
| 2011 — Merger and restructuring accruals(c) | \$ 3 | \$19 | \$(13) | \$— | \$ 9 |

(a) The “Other” activity is related to reserves associated with dispositions of businesses, reserves reclassified to operations held-for-sale, reclassifications among reserve accounts, and the impacts of foreign currency translation.

(b) Includes reserves for doubtful accounts receivable and notes receivable.

(c) Included in accrued liabilities in our Consolidated Balance Sheets. These accruals represent employee severance and benefit costs and transitional costs.

INDEX TO EXHIBITS

| <u>Exhibit No.</u> | <u>Description</u> |
|------------------------|---|
| 3.1 | — Third Restated Certificate of Incorporation [Incorporated by reference to Exhibit 3.1 to Form 10-Q for the quarter ended June 30, 2010]. |
| 3.2* | — Amended and Restated By-laws of Waste Management, Inc. |
| 4.1 | — Specimen Stock Certificate [Incorporated by reference to Exhibit 4.1 to Form 10-K for the year ended December 31, 1998]. |
| 4.2 | — Indenture for Subordinated Debt Securities dated February 3, 1997, among the Registrant and The Bank of New York Mellon Trust Company, N.A. (the current successor to Texas Commerce Bank National Association), as trustee [Incorporated by reference to Exhibit 4.1 to Form 8-K dated February 7, 1997]. |
| 4.3 | — Indenture for Senior Debt Securities dated September 10, 1997, among the Registrant and The Bank of New York Mellon Trust Company, N.A. (the current successor to Texas Commerce Bank National Association), as trustee [Incorporated by reference to Exhibit 4.1 to Form 8-K dated September 10, 1997]. |
| 4.4 | — Officers' Certificate delivered pursuant to Section 301 of the Indenture dated September 10, 1997 by and between Waste Management, Inc. and The Bank of New York Mellon Trust Company, N.A., as Trustee, establishing the terms and form of Waste Management, Inc.'s 2.60% Senior Notes due 2016 [Incorporated by reference to Exhibit 4.1 to Form 10-Q for the quarter ended September 30, 2011]. |
| 4.5 | — Guarantee Agreement by Waste Management Holdings, Inc. in favor of The Bank of New York Mellon Trust Company, N.A., as Trustee for the holders of Waste Management, Inc.'s 2.60% Senior Notes due 2016 [Incorporated by reference to Exhibit 4.2 to Form 10-Q for the quarter ended September 30, 2011]. |
| 4.6* | — Schedule of Officers' Certificates delivered pursuant to Section 301 of the Indenture dated September 10, 1997 establishing the terms and form of Waste Management, Inc.'s Senior Notes. Waste Management and its subsidiaries are parties to debt instruments that have not been filed with the SEC under which the total amount of securities authorized does not exceed 10% of the total assets of Waste Management and its subsidiaries on a consolidated basis. Pursuant to paragraph 4(iii)(A) of Item 601(b) of Regulation S-K, Waste Management agrees to furnish a copy of such instruments to the SEC upon request. |
| 10.1† | — 2009 Stock Incentive Plan [Incorporated by reference to Appendix B to the Proxy Statement on Schedule 14A filed March 25, 2009]. |
| 10.2† | — 2005 Annual Incentive Plan [Incorporated by reference to Appendix D to the Proxy Statement on Schedule 14A filed April 8, 2004]. |
| 10.3† | — Employee Stock Purchase Plan [Incorporated by reference to Appendix A to the Proxy Statement on Schedule 14A filed March 25, 2009]. |
| 10.4† | — Waste Management, Inc. 409A Deferral Savings Plan. [Incorporated by reference to Exhibit 10.4 to Form 10-K for the year ended December 31, 2006]. |
| 10.5† | — 1993 Stock Incentive Plan [Incorporated by reference to Exhibit 10.2 to Form 10-K for the year ended December 31, 1998]. |
| 10.6† | — 2000 Stock Incentive Plan [Incorporated by reference to Appendix B to the Proxy Statement on Schedule 14a filed April 6, 2000]. |
| 10.7† | — 2004 Stock Incentive Plan [Incorporated by reference to Appendix C to Proxy Statement on Schedule 14A filed April 8, 2004]. |

- 10.8 — \$2 Billion Amended and Restated Revolving Credit Agreement dated as of May 9, 2011 by and among Waste Management, Inc. and Waste Management Holdings, Inc. and certain banks party thereto, Bank of America, N.A., as Administrative Agent, JPMorgan Chase Bank, N.A. and Barclays Capital, as Syndication Agents, Deutsche Bank Securities Inc. and The Royal Bank of Scotland PLC, as Documentation Agents, BNP Paribas and Citibank, N.A., as Co-Documentation Agents and Merrill Lynch, Pierce, Fenner & Smith Incorporated, J.P. Morgan Securities LLC, and Barclays Capital, as Joint Lead Arrangers and Book Managers [Incorporated by reference to Exhibit 10.1 to Form 10-Q for the quarter ended June 30, 2011].
- 10.9 — CDN \$410,000,000 Credit Facility Credit Agreement by and between Waste Management of Canada Corporation (as Borrower), Waste Management, Inc. and Waste Management Holdings, Inc. (as Guarantors), BNP Paribas Securities Corp. and Scotia Capital (as Lead Arrangers and Book Runners) and Bank of Nova Scotia (as Administrative Agent) and the Lenders from time to time party to the Agreement dated as of November 30, 2005 [Incorporated by reference to Exhibit 10.32 to Form 10-K for the year ended December 31, 2005].
- 10.10 — First Amendment Agreement dated as of December 21, 2007 to a Credit Agreement dated as of November 30, 2005 by and between Waste Management of Canada Corporation as borrower, Waste Management, Inc. and Waste Management Holdings, Inc. as guarantors, the lenders from time to time party thereto and the Bank of Nova Scotia as Administrative Agent [Incorporated by reference to Exhibit 10.28 to Form 10-K for the year ended December 31, 2007].
- 10.11† — Employment Agreement between the Company and Cherie C. Rice dated August 26, 2005 [Incorporated by reference to Exhibit 10.1 to Form 8-K dated August 26, 2005].
- 10.12† — Employment Agreement between the Company and Greg A. Robertson dated August 1, 2003 [Incorporated by reference to Exhibit 10.2 to Form 10-Q for the quarter ended June 30, 2004].
- 10.13† — Employment Agreement between the Company and Puneet Bhasin dated December 7, 2009 [Incorporated by reference to Exhibit 10.12 to Form 10-K for the year ended December 31, 2009].
- 10.14† — Employment Agreement between the Company and Duane C. Woods dated October 20, 2004 [Incorporated by reference to Exhibit 10.2 to Form 8-K dated October 20, 2004].
- 10.15† — Employment Agreement between the Company and David Steiner dated as of May 6, 2002 [Incorporated by reference to Exhibit 10.1 to Form 10-Q for the quarter ended March 31, 2002].
- 10.16† — Employment Agreement between the Company and James E. Trevathan dated as of June 1, 2000 [Incorporated by reference to Exhibit 10.20 to Form 10-K for the year ended December 31, 2000].
- 10.17† — Employment Agreement between Recycle America Alliance, L.L.C. and Patrick DeRueda dated as of August 4, 2005 [Incorporated by reference to Exhibit 10.1 to Form 8-K dated August 4, 2005].
- 10.18† — Employment Agreement between the Company and Robert G. Simpson dated as of October 20, 2004 [Incorporated by reference to Exhibit 10.1 to Form 8-K dated October 20, 2004].
- 10.19† — Employment Agreement between the Company and Barry H. Caldwell dated as of September 23, 2002 [Incorporated by reference to Exhibit 10.24 to Form 10-K for the year ended December 31, 2002].
- 10.20† — Employment Agreement between the Company and David Aardsma dated June 16, 2005 [Incorporated by reference to Exhibit 10.1 to Form 8-K dated June 16, 2005].
- 10.21† — Employment Agreement between the Company and Rick L Wittenbraker dated as of November 10, 2003 [Incorporated by reference to Exhibit 10.30 to Form 10-K for the year ended December 31, 2003].
- 10.22† — Employment Agreement between Wheelabrator Technologies Inc. and Mark A. Weidman dated May 11, 2006 [Incorporated by reference to Exhibit 10.1 to Form 8-K dated May 11, 2006].
- 10.23† — Employment Agreement between the Company and Jeff Harris dated December 1, 2006 [Incorporated by reference to Exhibit 10.1 to Form 8-K dated December 1, 2006].
- 10.24† — Employment Agreement between the Company and Michael Jay Romans dated January 25, 2007 [Incorporated by reference to Exhibit 10.1 to Form 8-K dated January 25, 2007].

- 10.25† — Resignation Agreement by and between the Company and Michael Jay Romans dated June 14, 2011 [Incorporated by reference to Exhibit 10.2 to Form 10-Q for the quarter ended June 30, 2011].
- 10.26† — Employment Agreement between Waste Management, Inc. and Brett Frazier dated July 13, 2007 [Incorporated by reference to Exhibit 10.1 to Form 8-K dated July 13, 2007].
- 10.27† — Amendment to Employment Agreement between the Company and Jim Trevathan [Incorporated by reference to Exhibit 10.3 to Form 8-K dated March 9, 2011].
- 10.28† — Amendment to Employment Agreement by and between the Company and Duane C. Woods [Incorporated by reference to Exhibit 10.4 to Form 8-K dated March 9, 2011].
- 10.29† — Amendment to Employment Agreement between the Company and Brett W. Frazier [Incorporated by reference to Exhibit 10.5 to Form 10-Q for the quarter ended March 30, 2011].
- 10.30† — Amendment to Employment Agreement by and between the Company and Jeff Harris [Incorporated by reference to Exhibit 10.6 to Form 10-Q for the quarter ended March 30, 2011].
- 10.31† — Employment Agreement between the Company and Carl V. Rush [Incorporated by reference to Exhibit 10.7 to Form 10-Q for the quarter ended March 30, 2011].
- 10.32† — Employment Agreement between the Company and Grace Cowan [Incorporated by reference to Exhibit 10.8 to Form 10-Q for the quarter ended March 30, 2011].
- 10.33† — Employment Agreement between the Company and Steven C. Preston dated October 5, 2011 [Incorporated by reference to Exhibit 10.1 to Form 8-K dated October 2, 2011].
- 10.34† — Employment Agreement between the Company and James C. Fish, Jr. dated August 15, 2011 [Incorporated by reference to Exhibit 10.2 to Form 10-Q for the quarter ended September 30, 2011].
- 10.35† — Employment Agreement between the Company and William K. Caesar dated August 23, 2011 [Incorporated by reference to Exhibit 10.3 to Form 10-Q for the quarter ended September 30, 2011].
- 10.36† — Form of 2011 Performance Share Unit Award Agreement [Incorporated by reference to Exhibit 10.1 to Form 8-K dated March 9, 2011].
- 10.37† — Form of 2011 Stock Option Award Agreement [Incorporated by reference to Exhibit 10.2 to Form 8-K dated March 9, 2011].
- 10.38† — Form of 2010 Performance Share Unit Award Agreement [Incorporated by reference to Exhibit 10.1 to Form 8-K dated March 9, 2010].
- 10.39† — Form of 2010 Stock Option Unit Award Agreement [Incorporated by reference to Exhibit 10.2 to Form 8-K dated March 9, 2010].
- 10.40† — Form of 2009 Performance Share Unit Award Agreement [Incorporated by reference to Exhibit 10.1 to Form 8-K dated February 24, 2009].
- 12.1* — Computation of Ratio of Earnings to Fixed Charges.
- 21.1* — Subsidiaries of the Registrant.
- 23.1* — Consent of Independent Registered Public Accounting Firm.
- 31.1* — Certification Pursuant to Rule 13a-14(a) and 15d-14(a) under the Securities Exchange Act of 1934, as amended, of David P. Steiner, President and Chief Executive Officer.
- 31.2* — Certification Pursuant to Rule 13a-14(a) and 15d-14(a) under the Securities Exchange Act of 1934, as amended, of Steven C. Preston, Executive Vice President — Finance, Recycling & Energy Services.
- 32.1* — Certification Pursuant to 18 U.S.C. §1350 of David P. Steiner, President and Chief Executive Officer.
- 32.2* — Certification Pursuant to 18 U.S.C. §1350 of Steven C. Preston, Executive Vice President — Finance, Recycling & Energy Services.
- 95* — Mine Safety Disclosures.
- 101.INS** — XBRL Instance Document.

101.SCH** — XBRL Taxonomy Extension Schema Document.
101.CAL** — XBRL Taxonomy Extension Calculation Linkbase Document.
101.DEF** — XBRL Taxonomy Extension Definition Linkbase Document.
101.LAB** — XBRL Taxonomy Extension Labels Linkbase Document.
101.PRE** — XBRL Taxonomy Extension Presentation Linkbase Document.

* Filed herewith.

** Furnished herewith.

† Denotes management contract or compensatory plan or arrangement.

Non-GAAP Measure

Our letter to Shareholders, Customers, Employees and Communities included in this 2011 Annual Report presents adjusted earnings per diluted share (adjusted EPS), which excludes certain items affecting comparability of our results. Adjusted EPS is not defined by generally accepted accounting principles (GAAP). Please see below for a reconciliation of the differences between adjusted EPS and earnings per diluted share calculated in accordance with GAAP. We believe that non-GAAP measures provide useful information to investors by excluding items that the Company does not believe reflect its fundamental business performance and/or are not representative or indicative of our results of operations. Non-GAAP measures should be viewed in addition to, and not in lieu of, the comparable GAAP measure.

| | Year Ended December 31, 2011 (Dollars in Millions, Except Per Share Amounts) (Unaudited) | |
|--|---|-----------------------------|
| <u>Adjusted Earnings Per Diluted Share</u> | <u>After-tax Amount (a)</u> | <u>Per Share Amount</u> |
| Net Income and Earnings Per Diluted Share, as reported | \$ 961 | \$2.04 |
| Adjustments to Net Income and Earnings Per Diluted Share: | | |
| Litigation | 16 | |
| Restructuring | 11 | |
| Expense from divestitures, asset impairments and unusual items, net | 7 | |
| Results of the acquired Oakleaf operations and related integration costs | 7 | |
| Landfill operating costs (b) | 5 | |
| | <u>46</u> | <u>0.10</u> |
| Adjusted Net Income and Earnings Per Diluted Share | <u>\$1,007</u> | <u>\$2.14</u> |

- (a) Tax expense attributable to each adjustment was as follows: Litigation- \$8 million; Restructuring- \$6 million; Expense from divestitures, asset impairments and unusual items, net- \$3 million; Results of the acquired Oakleaf operations and related integration costs- \$4 million; and Landfill operating costs- \$3 million.
- (b) Adjustments in 2011 consisted of after-tax charges of \$11 million due to the changes in risk-free interest rates offset by an after-tax benefit of \$6 million due to decreases in environmental remediation reserves and closure and post-closure costs.

BOARD OF DIRECTORS

BRADBURY H. ANDERSON (C, N)

Retired Vice Chairman
and Chief Executive Officer
Best Buy Co., Inc.

PASTORA SAN JUAN CAFFERTY (C, N)

Professor Emerita
School of Social Service Administration
University of Chicago

FRANK M. CLARK, JR. (A, C)

Retired Chairman
and Chief Executive Officer
ComEd

PATRICK W. GROSS (A, N)

Chairman
The Lovell Group

JOHN C. POPE (C, N)

Chairman
PFI Group

W. ROBERT REUM (A, C, N)

Non-Executive Chairman of the Board
Waste Management, Inc.
Chairman, President,
and Chief Executive Officer
Amsted Industries Incorporated

STEVEN G. ROTHMEIER (A, C)

Chairman and Chief Executive Officer
Great Northern Capital

DAVID P. STEINER

President and Chief Executive Officer
Waste Management, Inc.

THOMAS H. WEIDEMEYER (A, N)

Retired Senior Vice President
and Chief Operating Officer
United Parcel Service, Inc.

(A) Audit Committee

(C) Management Development and
Compensation Committee

(N) Nominating and Governance
Committee

OFFICERS

DAVID P. STEINER

President and Chief Executive Officer

DAVID A. AARDSMA

Chief Sales and Marketing Officer

PUNEET BHASIN

Senior Vice President
and Chief Information Officer

BARRY H. CALDWELL

Senior Vice President,
Government Affairs and
Communications

GRACE M. COWAN

Senior Vice President,
Customer Experience

JAMES C. FISH, JR.

Senior Vice President,
Eastern Group

BRETT W. FRAZIER

Senior Vice President,
Southern Group

JEFF M. HARRIS

Senior Vice President,
Midwest Group

STEVEN C. PRESTON

Executive Vice President,
Finance, Recycling and
Energy Services

CARL V. RUSH, JR.

Senior Vice President,
Organic Growth

JAMES E. TREVATHAN

Executive Vice President,
Growth, Innovation and
Field Support

RICK L WITTENBRAKER

Senior Vice President,
General Counsel and
Chief Compliance Officer

DUANE C. WOODS

Senior Vice President,
Western Group

WILLIAM K. CAESAR

President
WM Recycle America, L.L.C.

MARK A. WEIDMAN

President
Wheelabrator Technologies Inc.

DON P. CARPENTER

Vice President, Tax

CHERIE C. RICE

Vice President, Finance
and Treasurer

GREG A. ROBERTSON

Vice President and
Chief Accounting Officer

LINDA J. SMITH

Corporate Secretary

CORPORATE HEADQUARTERS

Waste Management, Inc.
1001 Fannin, Suite 4000
Houston, Texas 77002
Telephone: (713) 512-6200
Facsimile: (713) 512-6299

INDEPENDENT AUDITORS

Ernst & Young LLP
5 Houston Center, Suite 1200
1401 McKinney Street
Houston, Texas 77010
(713) 750-1500

COMPANY STOCK

The Company's common stock is traded on the New York Stock Exchange (NYSE) under the symbol "WM." The number of holders of record of common stock based on the transfer records of the Company at February 10, 2012 was approximately 13,700. Based on security position listings, the Company believes it had at that date approximately 367,000 beneficial owners.

TRANSFER AGENT AND REGISTRAR

Computershare
480 Washington Boulevard
Jersey City, New Jersey 07310
(800) 969-1190

INVESTOR RELATIONS

Security analysts, investment professionals, and shareholders should direct inquiries to Investor Relations at the corporate address or call (713) 512-6574.

ANNUAL MEETING

The annual meeting of the stockholders of the Company is scheduled to be held at 11:00 a.m. on May 10, 2012 at: The Maury Myers Conference Center
Waste Management, Inc.
1021 Main Street
Houston, Texas 77002

WEB SITE

www.wm.com



Printed on 30% post-consumer recycled paper



1001 Fannin, Suite 4000 • Houston, Texas 77002
www.wm.com

Exhibit 2



WM Health Care Solutions Driver Training

- Introductions – Safety Briefing
- Regulated Medical Waste – Defined
- DOT Medical Waste Collection and Transportation Regulations and Guidelines
- Waste Management Inc. Medical Waste Acceptance Protocol
- Medical Waste Tracking and Documentation
- Blood Borne Pathogens
- Personal Protective Equipment
- Spill Control and Emergency Response

The above noted training was designed and intended to inform drivers in the proper methods, procedures and practices for safely handling, processing, transporting and tracking the pickup and delivery to disposal facilities for Medical Waste

Name _____

Signature _____ Date _____

Trainer _____

Copy to File

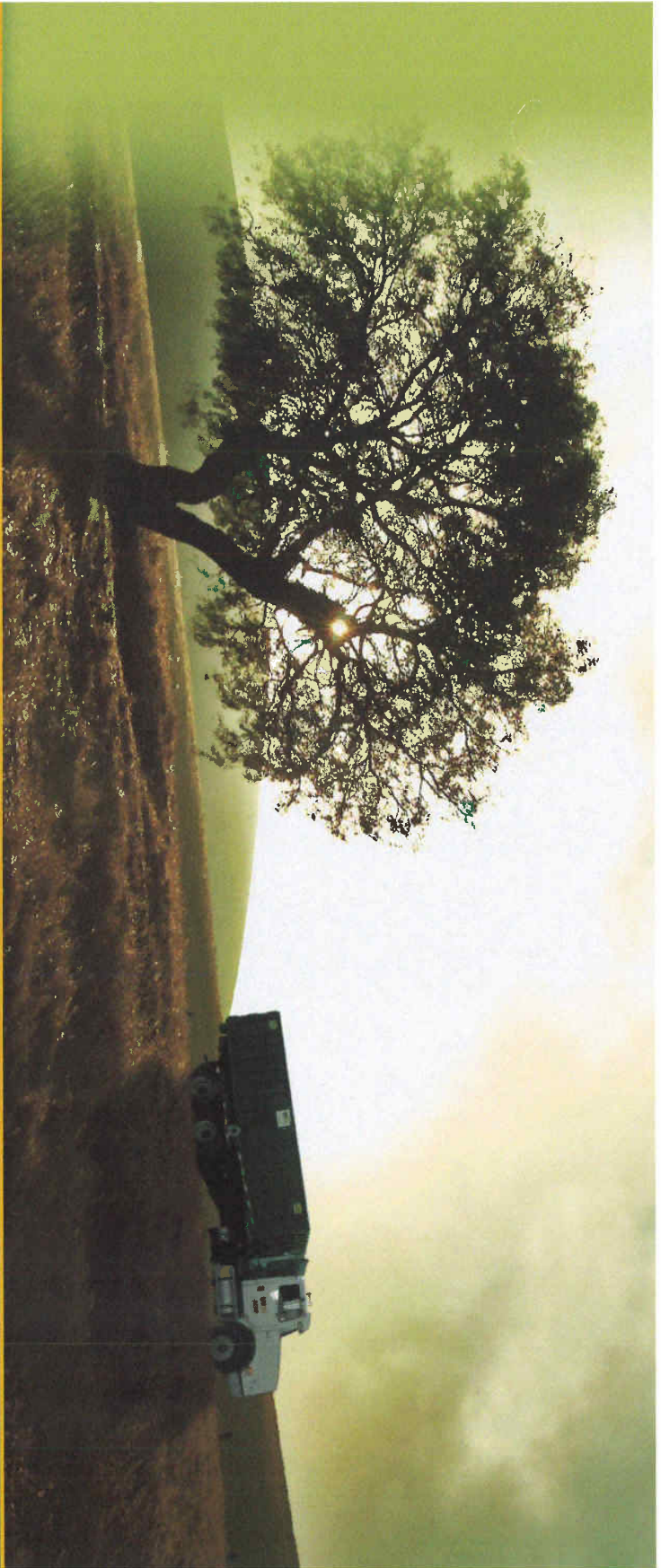

BLOOD BORNE PATHOGENS
Employee Training
WMM HEATLTHCARE SOLUTIONS



BBP: Requirements of the Regulations

- Must make copy of regulations available
- Must explain blood borne disease hazards and symptoms and how you can be exposed
- Provide a written Exposure Control Plan
- Do hazard assessment and explain how to recognize the risks
- Explain how to protect yourself and methods including PPE
- Signs, labels and color coding required
- Provide training

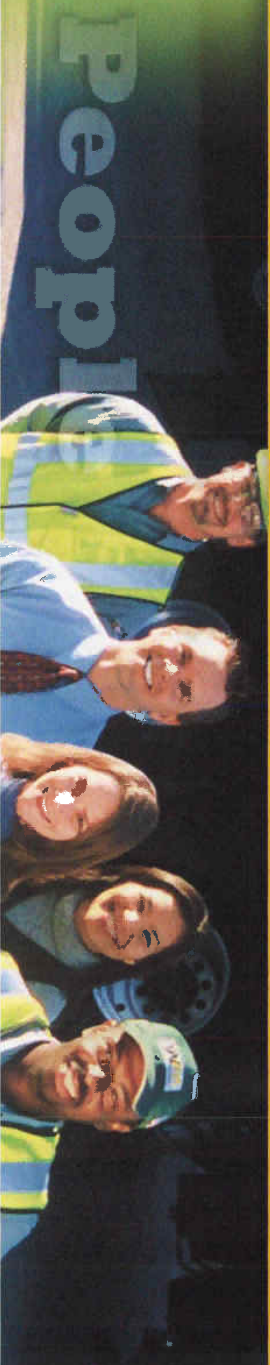

BBP: Requirements of the Regulations

- Additional Training will include:
- Information on Hepatitis B vaccine
- What to do if you are exposed
- DOT requirements for packaging, shipping, handling, and storage of regulated medical waste (RMW)

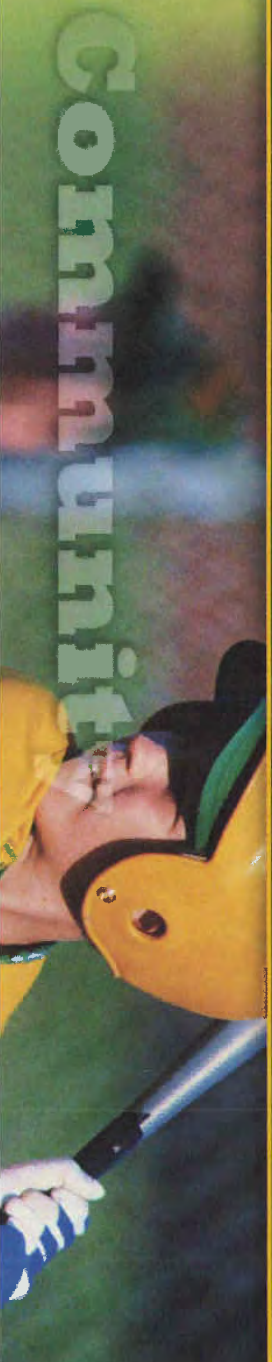

BBP: Hazards and Symptoms

- Definition of BBP:
 - Pathogenic (disease causing) microorganism that are in the human blood. They can include the common cold but can be as deadly as AIDS.
- Pathogens we are concerned with:
 - Human Immunodeficiency Virus (HIV)
 - Hepatitis B (HBV)
 - Hepatitis C (HBC)



BBP: Hazards and Symptoms

- Danger does not just exist in the blood
- Other potentially infectious substances (OPIS) include:
 - human body fluids
 - semen
 - vaginal secretions
 - any saliva or other body fluid contaminated with blood
 - cultures grown to have HIV, HPB, HPC
 - cerebrospinal fluid
 - synovial fluid
 - pleural fluid
 - pericardial fluid
 - peritoneal fluid
 - amniotic fluid

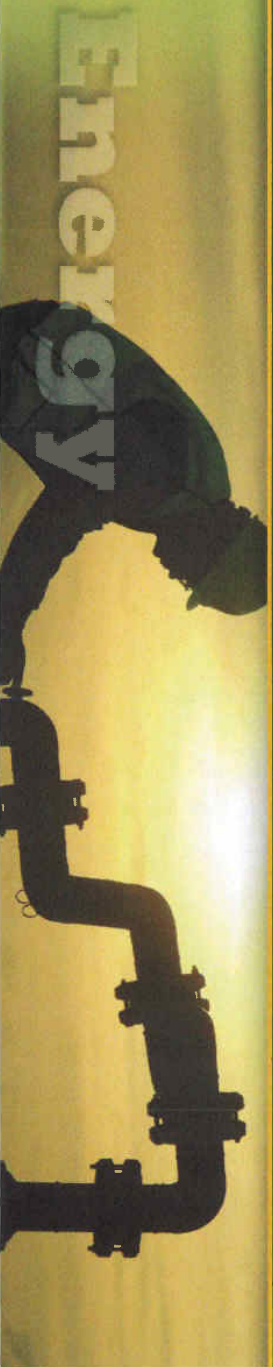

BBP: Hazards and Symptoms

- BBP are spread when blood or body fluid of infected person gets mixed with uninfected person
- This could be by by:
 - unprotected sex
 - needle stick
 - sharing of needles
 - splash or spraying of fluids to nose, eyes, mouth etc.
 - contact with broken skin
- CANNOT BE SPREAD BY: sneezing, coughing or using same toilet seats and faucets.



BBP: Hazards and Symptoms

- There must be some way, a vector, for the disease to pass from one person to another
- Definition: Exposure
 - eye, mouth, other mucus membrane, non-intact skin or parenteral contact with blood or OPIS resulting from the performance of a employees duties.



BBP: Hazards and Symptoms

- HIV:
 - can cause Acquired Immunodeficiency Disease (AIDS)
 - attacks human immune or defense system
 - makes it easy to catch any disease and body is not able to fight it off
 - common disease associated with AIDS are Kaposi's sarcoma and pneumocystic pneumonia
 - no vaccine available
 - no known cases of HIV converters in the medical waste industry



BBP: Hazards and Symptoms

- HBV
 - infection of the liver
 - flu like symptoms: fever, fatigue and Jaundice (yellowing of the skin and whites of eyes)
 - can live outside the body for much longer; 72 hours
 - greater risk of exposure
 - have vaccine available and also a booster
 - we will discuss vaccine shortly



BBP: Hazards and Symptoms

- HCV
 - infection of the liver
 - flu like symptoms: fever, fatigue and Jaundice (yellowing of the skin and whites of eyes)
 - can live outside the body for much longer; 72 hours
 - greater risk of exposure
 - no vaccine available
 - low risk of infection currently



Occupational Health Program: Vaccinations/Immunizations

- Employee must begin HepB series within 10 days of assignment to job
- Vaccination at not cost to employee
- HepB Schedule:
 - 1st at 10 days to duty
 - 2nd one month later
 - 3rd 5 months after 2nd
- tier: blood test to check for antibodies, 1 month after 3rd



Occupational Health Program: Vaccinations/Immunizations

- Tetanus shots
- determine if employee ever had them as a child
- if no follow series requirements
- if yes - booster required every 5 years



Occupational Health Program: Communicating with Employee

- You have the right to your personal medical information
- You must be told of overexposure and how to protect yourself
- You must sign Annual Notification of Employee Rights to Access Safety and Health exposure and Medical Records
- The physician is responsible for giving you your results
- All personal information is kept at the clinic and Corporate Medical Officer (CMO)
- The company only sees a summary of the results as it relates to your job function



Employee Exposure Control Plan: Overview

- Plan to help control the hazards of infectious disease
- It covers:
 - Program Statement (Universal Precautions)
 - Exposure Determination
 - Methods of Compliance
 - Occupational Health Program
 - Communication of Hazards (Training)

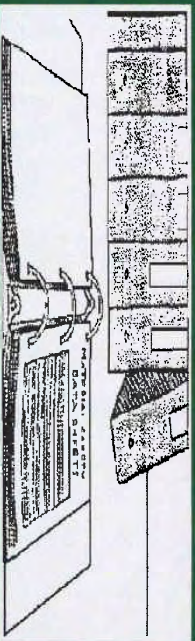

Employee Exposure Control Plan: Program Statement

- Universal Precautions
 - assume all untreated medical waste is contaminated
 - assume all humans are contaminated
 - assume the worst, always protect yourself for the worst



Employee Exposure Control Plan: **Methods of Compliance**

- Developed to eliminate or minimize employee exposure
- Include:
 - Engineering Controls
 - Work Practice Controls
 - Safe Waste Handling Procedures
 - Individual Responsibility
 - Personal Protective Equipment
 - Housekeeping
 - Spills and Emergency Response

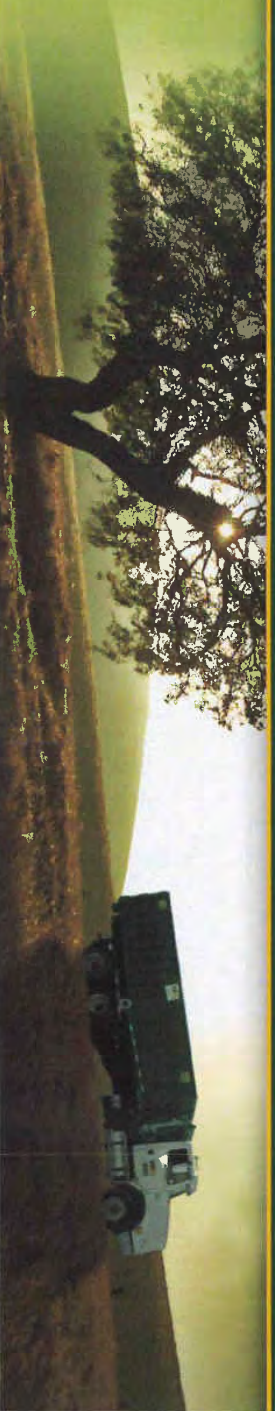

Employee Exposure Control Plan: Methods of Compliance

- Personal Hygiene:
 - hand washing
 - showering
 - consumption of foods in plant etc.
 - use of tobacco products in appropriate places

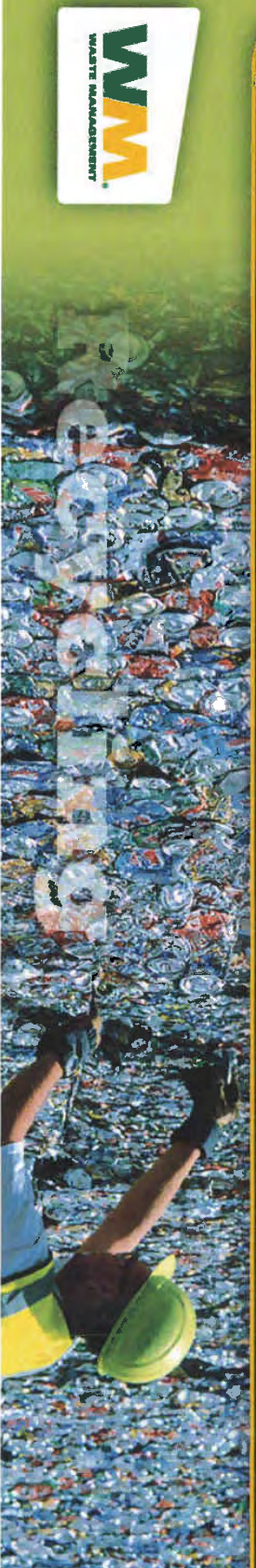
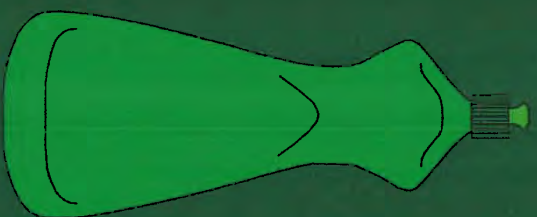

Employee Exposure Control Plan: Methods of Compliance

- Safe Handling: Proper Waste Packaging
 - should be packaged properly by the generator
 - each package must be designed, constructed, maintained, filled and weight limited, and closed so that there is:
 - no release to environment
 - effectiveness of package is not reduced

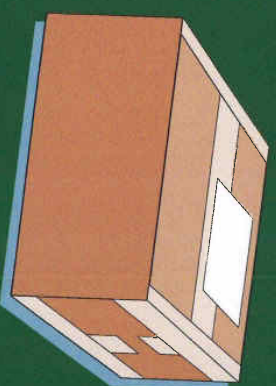

Employee Exposure Control Plan: **Methods of Compliance**

- Safe Handling: Proper Waste Packaging
- Outer Packaging:
 - Must be properly labeled "BIOHAZARD - Regulated Medical Waste UN 3291"



Employee Exposure Control Plan: Methods of Compliance

- Safe Handling: Proper Waste Packaging
 - Containers in general must be:
 - maximum net capacity of 119 gallons
 - maximum net mass of 882 pounds
 - packaged as non-bulk
- Any containers not meeting the above restrictions must have a exemption by DOT



Employee Exposure Control Plan: Methods of Compliance

- Safe Handling: Proper Waste Packaging:
 - Special Condition:
 - Sharps
 - Cultures and stocks:
 - cultures: used to identify bacteria/virus and antibiotic needed
 - stocks: microorganisms grown specifically for testing or QA in labs (very concentrated)
- Chemotherapy and Pathological wastes which must be segregated



Employee Exposure Control Plan: Methods of Compliance

- Safe Handling: Proper Waste Packaging
 - Sharps:
 - must be puncture resistant, leak proof and have the proper markings
 - must have labels which are orange, orange red, the international biohazard symbol; the word BIOHAZARD in contrasting color



Employee Exposure Control Plan: Methods of Compliance

- Safe Handling: Proper Waste Packaging
 - Cultures and Stocks:
 - must have containers meeting all other requirements
 - must also go through special testing
 - packaging must be DOT certified
 - must meet standards for Packaging Group (PG) II
 - all packages which qualify for a DOT PG certification go through special testing
 - PG I most dangerous; PG II moderate danger; PG III least dangerous
- there are several testing requirements



Employee Exposure Control Plan: Methods of Compliance

- Safe Handling: Proper Waste Packaging
 - Container Specification Sheets:
 - in Standard Emergency Response Information
 - should be shared with the customer
 - waste must meet those guidelines to be accepted
 - key details on sheet:
 - container style
 - UN designation (labeling)
 - PG II
 - maximum gross weight of the container allowed



Employee Exposure Control Plan: **Methods of Compliance**

- Safe Handling: Proper Waste Packaging
- Labeling must also include:
 - OSHA biohazard symbol
 - word BIOHAZARD
 - words Regulated Medical Waste
 - UN 3291
 - DOT exemption number if applicable



Employee Exposure Control Plan: Methods of Compliance

- Safe Handling: Proper Waste Holding/Lifting; Bracing and Blocking:
 - use proper lifting techniques - bend at knees
 - use loading equipment i.e. hand trucks, dollies
 - brace and block all containers in back of truck
 - stack waste in same position as received

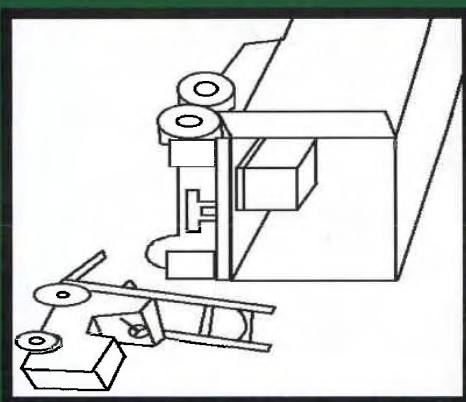

Employee Exposure Control Plan: Methods of Compliance

- Safe Handling: Storage:
 - waste should be maintained in an enclosure
 - must be in designated accumulation areas
 - secured against access to unauthorized personnel
 - secure to rodents, insects, etc.
 - marked with proper warnings



Employee Exposure Control Plan: Methods of Compliance

- Safe Handling:
 - only authorized employees should handle untreated regulated medical waste
 - individual responsibilities:
 - Drivers
 - Processing/Plant Operators



Employee Exposure Control Plan: Methods of Compliance

- Safe Handling: Driver Responsibilities
 - this training will also cover requirements for Carriage By Public Highway - 49 CFR 390-397
 - do not accept leaking or improperly packaged wastes
 - do not package waste for customers
 - drivers are not to repack waste for customers



Employee Exposure Control Plan: Methods of Compliance

- Safe Handling: Driver Responsibilities
 - look at each container closely:
 - Is it labeled properly? : symbol, BIOHAZARD, Regulated Medical Waste, UN3291
 - Is it closed?
 - Is it leaking?
 - Is there waste/contamination on the outside?
 - Are there loose sharps?
 - Does it contain cultures and stocks? Is package DOT certified?



Employee Exposure Control Plan: Methods of Compliance

- Safe Handling: Driver Responsibilities
 - must wear all appropriate PPE
 - must use proper lifting
 - must brace and lock containers
- must have proper shipping documents:
 - shipping documents:
 - requirements
 - what it should include
 - vehicle markings



Employee Exposure Control Plan: Methods of Compliance

- Safe Handling: Driver Responsibilities
 - shipping documents: requirements
 - RMW cannot be transported without complete shipping documents
 - they must be readily available, recognizable, distinguishable
 - must be within reach of driver while seated and with seat belt
 - must be stored in holder mounted on driver door on on seat when driver is not in vehicle
 - must be legible
 - must be in English
 - must have emergency response information and phone number



Employee Exposure Control Plan: Methods of Compliance

- Safe Handling: Driver Responsibilities
 - shipping documents: what it must include
 - Proper shipping name: Regulated Medical Waste n.o.s.
 - Hazard Class or Division: 6.2
 - Identification Number: UN 3291
 - Packing Group: PG II
 - total by net or gross mass or capacity must be listed
 - DOT exemption # if applicable
- Shippers Certification: must be legibly signed manually, by typewriter or other mechanical means by the shipper
- all signed documents must be kept for 3 years



Employee Exposure Control Plan: Methods of Compliance

- Safe Handling: Driver Responsibilities
 - Vehicle Markings:
 - RMW is not required to be placarded unless:
 - it is transporting at least one full exempted container; **or**
 - when transporting non-bulk containers from a single facility weighing 8,820 lbs or more
 - If markings are required:
 - driver is responsible for insuring the markings are displayed
 - the marking displayed is **3291**; displayed using white, square-on-point configuration, on the two sides of the vehicle and on the front and back of the vehicle



Employee Exposure Control Plan: Methods of Compliance

- Safe Handling: Plant/Processing Responsibilities
 - Look at each container closely:
 - Is it labeled? What is the label?
 - Is it closed?
 - Is it leaking?
 - Report any problems to your supervisor.
 - If a container is leaking:
 - process immediately or put in another container
 - clean up spill immediately
 - report to supervisor
 - complete Incident Questionnaire
- Use proper lifting techniques and appropriate PPE





PERSONAL PROTECTIVE EQUIPMENT Employee Training



Employee Exposure Control Plan: Personal Protective Equipment

- PPE included are:
 - safety glasses
 - safety toe and hard soled safety shoes
 - water resistant safety boots
 - puncture/cut resistant gloves
 - face shield - above shoulder work; leaking material; tub washing; spill clean up
 - aprons - chemical resistant
 - respirators as needed
 - uniforms - provided and laundered at no cost to you
- PPE required while loading/unloading:
 - safety toe and hard soled safety shoes
 - puncture/cut resistant gloves
 - uniform



Employee Exposure Control Plan: Personal Protective Equipment

- PPE Care:
 - must inspect daily
 - must be cleaned daily
 - replace as needed
 - no cost to employee
 - \$100 towards safety boots
 - for specific care see Exposure Control Plan



EDUCATION



Employee Exposure Control Plan: Personal Protective Equipment

- PPE Limitations:
 - it only protects you if you wear it
 - replace worn equipment
 - disposable should be discarded after each use
 - will not protect against all hazards 100%
 - know the limitations of the equipment and use caution





Regulated Medical Waste Acceptance Training

Identification, Segregation, &
Transportation



© 2010 WM Healthcare Solutions, Inc. All services are provided by WM Healthcare Solutions, Inc., a Waste Management company.

THINK GREEN.



WM000309

Agenda

- Recognize how to classify medical waste
- Define Medical Waste
 - What is RMW?
 - How to safely handle RMW?
 - “Acceptable” vs “Unacceptable Waste Streams
 - Handling “Unacceptable” Waste Streams



THINK GREEN.



What is Regulated Medical Waste (RMW)?

Regulated medical waste is waste saturated with enough blood or OPIM that it could contaminate the environment or people if the bag breaks and the contents are released.



THINK GREEN.



Regulated Medical Waste: Sharps

- Sharps are syringes, needles, blades, scalpels, lancets, broken glass and any other contaminated sharp object



© 2010 WM Healthcare Solutions, Inc. All services are provided by WM Healthcare Solutions, Inc., a Waste Management company.

THINK GREEN.



Regulated Medical Waste: Biohazardous Waste

- Lab Waste
 - Specimens or cultures, stocks of infectious agents, live and attenuated vaccines, and culture mediums
- Human Surgery Specimens
 - Human or animal parts or tissues removed surgically or by autopsy.
- Contaminated Animals
 - Animal carcasses, body parts and bedding contaminated with diseases that can be spread to humans



THINK GREEN.



Regulated Medical Waste: Biohazardous Waste

- Blood or Bodily Fluids
 - Which are dripping or capable of being poured or spilled and items visibly soiled with blood
- Trace Chemotherapy Waste
 - Which are contaminated through contact with or having previously contaminated chemotherapy agents, such as gloves, disposable gowns, or IV bags.



THINK GREEN.



Regulated Medical Waste: Biohazardous Waste

➤ Chemotherapy Waste

- Chemotherapy contaminated wastes with trace (<15cc) amounts of chemo or antineoplastic agents may be packaged in a yellow bag and disposed of as trace contaminated chemotherapy waste.



THINK GREEN.



Handling RMW Safely

- To reduce exposures by contact:
 - Keep hands away from mouth, nose, eyes, face
 - Wash hands immediately after contact or when work is completed



THINK GREEN.





Handling RMW Safely

- To reduce exposures by contact:
 - Decontaminate work surfaces immediately after spills and after work
 - Wear appropriate PPE
 - Do not smoke, eat, drink or store food in work areas



THINK GREEN.



Handling RMW Safely

➤ Packaging

- RMW must be properly packaged to prevent potential leaks.
 - Red bagged waste that has the potential to leak must be double bagged.
 - Totes must be tightly secured.



THINK GREEN.





Handling RMW Safely

➤ Packaging RMW Boxes

- Must have the word “BIO-HAZARD”
- Must have universal symbol
- Must be sealed with tape
- Must have the name of the Generator on each container
- Fiber drums must be kept closed
- There must be a bar-code affixed to the outside of each box or container



THINK GREEN.



Handling RMW Safely

- RMW Transport
 - When lifting boxes, support them from underneath



THINK GREEN.



Regulated Medical Waste Segregation: Training and Education

- Proper segregation of medical waste can reduce the errors associated with improper disposal.



© 2010 WM Healthcare Solutions, Inc. All services are provided by WM Healthcare Solutions, Inc., a Waste Management company.

THINK GREEN.



Unacceptable Waste Streams

- Hazardous Wastes (RCRA)



© 2010 WM Healthcare Solutions, Inc. All services are provided by WM Healthcare Solutions, Inc., a Waste Management company.

THINK GREEN.



Unacceptable Waste Streams

- Radioactive Waste



© 2010 WM Healthcare Solutions, Inc. All services are provided by WM Healthcare Solutions, Inc., a Waste Management company.

THINK GREEN.



WM000323

Inspecting Packages Prior to Transport

- Ensure that waste is properly labeled.
- Complete all waste tracking documentation.
- Verify that waste tracking document is accurate.
- **DO NOT LOAD UNACCEPTABLE WASTE ONTO THE TRUCK.**



THINK GREEN.



Transporting RMW Safely

- During RMW Transport
 - Have spill clean-up material (i.e. absorbent pads, bleach solution, etc.) available.
 - In the event of an incident, clean-up the spill, notify the supervisor, and complete the necessary follow-up procedures.



© 2010 WM Healthcare Solutions, Inc. All services are provided by WM Healthcare Solutions, Inc., a Waste Management company.

THINK GREEN.



Handling Unacceptable Waste Streams

- See Process Flow Diagram



© 2010 WM Healthcare Solutions, Inc. All services are provided by WM Healthcare Solutions, Inc., a Waste Management company.

THINK GREEN.



Regulated Medical Waste Management Training

Section 2 TEST



© 2010 WM Healthcare Solutions, Inc. All services are provided by WM Healthcare Solutions, Inc., a Waste Management company.

THINK GREEN.



TEST - Question 1

Household waste is considered Regulated Medical Waste (RMW).

True _____ or False _____



© 2010 WM Healthcare Solutions, Inc. All services are provided by WM Healthcare Solutions, Inc., a Waste Management company.

THINK GREEN.



TEST - Question 2

Under no circumstances may a container labeled with the words “infectious”, “sharps” and/or “regulated medical waste” or labeled with the biohazard symbol be disposed of in the regular trash.

True _____ or False _____



THINK GREEN.



TEST - Question 3

Regulated Medical Waste containers must:

- A) Contain the words “Bio-Hazard”**
- B) Show the name of waste generator**
- C) Be closed when being stored and during transport**
- D) All of the above**



THINK GREEN.



TEST - Question 4

A) Sharps may be disposed with regular trash

True or False

B) RMW may be placed into black bags

True or False

C) RMW should be packaged such that it will not leak out of its container

True or False



THINK GREEN.



TEST - Question 5

Which of the following are “acceptable” waste streams which can be transported by WMHS drivers/contractors?

- A) Regulated Medical Waste**
- B) Trace Chemotherapy Waste**
- C) Sharps Containers**
- D) All of the Above**



THINK GREEN.



TEST - Question 6

You may clean up a biological/RMW spill if:

- A) There is nobody else around to clean it up, even if you do not have the right supplies**
- B) You feel symptoms of exposure**
- C) You have the proper personal protection and are trained to do so**



THINK GREEN.



TEST - Question 7

Which of the following is not an “acceptable” waste stream for transport by WMHS or treatment at WMHS facilities?

- A) Radioactive Waste
- B) Hazardous Waste
- C) Nuclear Waste
- D) All of the above



THINK GREEN.



TEST - Question 8

If you have a Regulated Medical Waste spill, you should:

- A. Use bleach, diluted with 1:10 water, to disinfect the spill area
- B. Use only water to clean it up
- C. Dispose of the spill cleanup debris in the trash
- D. Leave it for someone else to clean up



THINK GREEN.

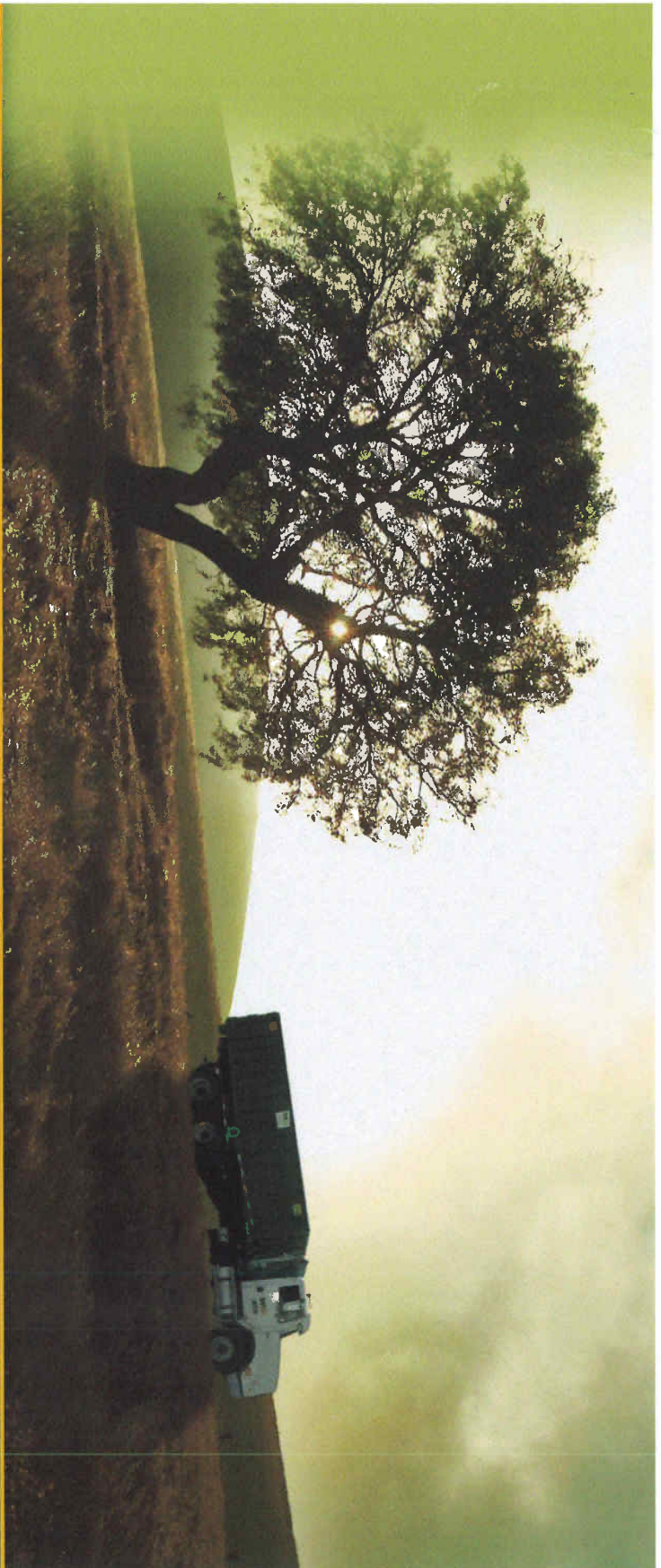

SPILL/EMERGENCY RESPONSE TRAINING Employee Training



Employee Exposure Control Plan: Housekeeping

- Decontaminate (clean) all areas, equipment tools which become contaminated or is potentially contaminated by untreated RMW daily
- Keep work area clear of clutter
- Floors and work surfaces must be decontaminated after each shift.



Employee Exposure Control Plan: Housekeeping

- Reusable containers must be decontaminated before going back to the customer
- Cargo area of the trailer/truck must be decontaminated before leaving the plant/station
- Clean cargo area when there is visible medical waste



Employee Exposure Control Plan: Housekeeping

- Spills and Emergency Response:
- Protecting yourself
- PPE for clean-up
- Clean up - process facilities and drivers
- Chemotherapy Spills
- Emergency Response
- Incident Reporting

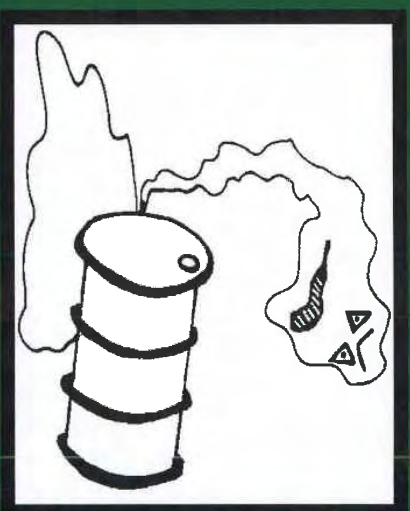

Employee Exposure Control Plan: Housekeeping

- Spills and Emergency Response:
 - Protecting yourself
 - remove any contaminated clothing
 - shower or
 - wash area with antibacterial/germicide soap
 - inspect body for any potential exposure



Employee Exposure Control Plan: Housekeeping

- Spills and Emergency Response:
 - Protecting yourself
 - remove any contaminated clothing
 - shower or
 - wash area with antibacterial/germicide soap
 - inspect body for any potential exposure



Employee Exposure Control Plan: Housekeeping

- Spills and Emergency Response:
 - PPE
 - wear appropriate PPE
 - Tyvec suit and booties may be needed for liquid spills (mainly drivers)
 - wear impermeable (non-liquid absorbing) gloves such as latex or nitrile
 - safety glasses and dusk mask if needed
 - face shield



Employee Exposure Control Plan: Housekeeping

- Spills and Emergency Response:
 - Clean up - Drivers/Collection Personnel:
 - place a red bag inside a fiberboard box or reusable container
 - shovel solids from spill into container
 - spray area with US EPA approved tuberculocidal disinfectant
 - spread absorb and over area and wait 10 min.
 - shovel absorb and and other items into container
 - spray area again with tuberculocidal disinfectant
 - decontaminate any equipment
 - dispose of all PPE used in container
 - wash hands thoroughly



Employee Exposure Control Plan: Housekeeping

- Spills and Emergency Response:
 - Chemotherapy Waste Spills
 - Follow all RMW spill procedures but add:
 - wear double gloves
 - eye goggles and mask
 - fluid resistant apron or Tyvecs
 - clean small solid spills with absorbent pads
 - do not let spill reach drains
 - place absorbent materials into re-usable tub and dump into incineration if at plant or send tub for incineration



Employee Exposure Control Plan: Housekeeping

- Spills and Emergency Response:
 - Chemotherapy Waste Spills
 - if it needs to go to incinerator place materials into red poly bags then into DOT certified container
 - Clean spill area 3 times using detergent then clean water
 - place PPE into container to be incinerated
 - decontaminate non-disposable PPE
 - disinfect any tools
 - wash hands thoroughly



Employee Exposure Control Plan: Housekeeping

- Spills and Emergency Response:
 - Emergency Response (ER)
 - Emergency Contingency Plan is part of operations plan
 - Standard Emergency Response Information for drivers
 - ER information must include:
 - technical name (RMW) and basic description
 - immediate hazards to health
 - risks for fire or explosion
 - immediate precautions
 - initial methods for spills/leaks
 - 1st Aid
 - fire control



Employee Exposure Control Plan: Housekeeping

- Spills and Emergency Response:
 - Emergency Response (ER)
 - must be printed in English
 - instructions must be stored away from RMW
 - must be immediately accessible
 - plant personnel should know where it is
 - drivers:
 - must be readily visible to anyone entering cab
 - must be within reach of driver while seated and with seat belt
 - must be stored in holder mounted on driver door on seat when driver is not in vehicle



Employee Exposure Control Plan: Housekeeping

- Spills and Emergency Response:
 - Emergency Response (ER)
 - drivers:
 - review the material in the permit book
 - you must review the shipping papers and make any additions or subtractions to the total quantity of waste if necessary



Employee Exposure Control Plan: Housekeeping

- Spills and Emergency Response:
 - Incident reporting:
 - Incident: see definition in back of exposure control plan
 - any containment failure
 - any package contents i.e. liquids, needles, spillage exposed
 - related to vehicles only: all incidents in vehicles require a DOT form 5800.1
 - Immediate reporting to DOT 800-number
 - Information needed for report
 - Written Notice to DOT



Employee Exposure Control Plan: Housekeeping



- Spills and Emergency Response:
 - Incident reporting: Immediate notice to DOT
 - 1-800-424-8802
 - Only required if RMW was a direct result of:
 - person is killed
 - person is hospitalized
 - estimated damage is over \$50,000
 - general public is evacuated 1hr or more
 - one or more transportation arteries (highways) is shut down 1 hr or more
 - flight patten of aircraft is diverted
 - fire, breakage, spillage or contamination of infectious substances
 - any other situation deemed necessary



Employee Exposure Control Plan: Housekeeping

- Spills and Emergency Response:
 - Incident reporting: Immediate notice to DOT
 - main roll for employees is to notify supervisor when an incident occurs
 - information needed for report
 - name and telephone of person reporting incident
 - name and address of the carrier/processing facility
 - date, time and location of incident
 - extent of injuries
 - type of incident and nature
 - classification, name and quantity of waste involved



Employee Exposure Control Plan: Housekeeping

- Spills and Emergency Response:
 - Incident reporting: written notice to DOT form 5800.1
 - must be submitted within 30 days of incident
 - required for all incidents where phone call is made
 - any unintentional release from RMW packages (most common)
 - 5800.1 must be sent to AMESH, Manager, and kept on file
 - employees fill out incident reports, supervisors fill out 5800.1
 - be sure it is accurate, on time and ever incident
 - must contact and communicate with supervisor
 - Examples: liquid leak, spilled solids, needle out of container



Training Requirements and Training Summary

- Must train new employees
- Must train when job functions change
- Must train annually thereafter for BBP-PPE; DOT training required only once every two years



Training Requirements and Training Summary

- Other related summary:
 - We must not accept containers that:
 - are leaking;
 - are improperly packaged;
 - are improperly closed;
 - have objects protruding from its walls; and
 - are not properly labeled or marked.
 - Sharps containers that contain untreated cultures and stocks must be in PG II certified containers



Training Requirements and Training Summary

- Other related summary:
 - waste must be properly marked:
 - “Regulated Medical Waste” universal Biohazard symbol and “Biohazard”
 - we cannot accept waste without properly completed shipping papers:
 - must be certified by shipper
 - must have quantities
 - must have all state and local requirements met
 - we cannot accept bulk waste without proper exemption packaging and paperwork



Tracking Document Training



Medical Waste Management Act

118040 – Tracking Records

The tracking documents shall include, but not be limited to, all of the following information:

- The name, address, and telephone number, and registration number of the transporter.
- The type and quantity of medical waste transported.
- The name, address, telephone number, permit number, and the signature of an authorized representative of the permitted facility receiving the medical waste.

Medical Waste Management Act

118040 – Tracking Records

- The date that the medical waste is collected or removed from the generator's facility, the date that the medical waste is received by the transfer station, the registered large quantity generator, or point of consolidation, if applicable, and the date that the medical waste is received by the treatment facility.
- Transporter must have completed tracking document in their possession while transporting waste.
- Transporters and generators will maintain a completed tracking document for three years.

Incorrectly Printed Tracking Documents



WASTE MANAGEMENT
MEDICAL WASTE WITH FORMER

MEDICAL WASTE TRACKING DOCUMENT

ROUTE NO. - 028

TRUCK NUMBER

DOCUMENT #: 0000109788

Generator No. 1 LINCOLN VILLAGE ASSISTED LIVING
 41040 Lincoln St
 Fremont, CA 94538-4314
 (510) 856-4373

Generator's US EPA ID No. _____

24-Hour Emergency Response
(800) 424-9300

State Generator's ID No. _____

| 2a. Description of Waste | 2b. Container Type | 2c. No. of Containers | 2d. lb. or Volume |
|--------------------------|---|-----------------------|-------------------|
| Pharmaceuticals | 45 Gallon Pharmaceutical Vials - 19 gal | | |
| TOTALS | | | |

7A. Transfer Facility:
 VMMS Hazardous Waste Management, Inc.
 2010 Enterprise Ave.
 Fremont, CA 94538
 Permit #: 75-85

7B. Transfer Facility:
 VM Healthcare Solutions, Inc.
 1986 Don Lee Road, Suite C
 Fremont, CA 94500
 Permit #: 75-73

7C. Incineration Facility:
 WAFERRC
 7905 State Hwy 85
 Anaheim, TX 77514
 Phone (800) 267-3913
 Permit #: MS11-2287-A

7D. Autoclave Facility:
 Waste Management
 1290 E Commercial Row
 Reno, NV 89512
 Phone (775) 783-2439
 Permit #: MS01-003

7E. Alternative Facility:
 VM Healthcare Solutions
 4280 Bendish Blvd
 Vernon, CA 90058
 Phone (323) 307-2557
 Permit #: TSO5T-81

Generator's Certification: I hereby declare that the contents of this consignment are fully and accurately described above by the proper shipping name and are classified, packaged, marked and labeled/placarded, and are in all respects in proper condition for transport by highway according to applicable international and national government regulations, including applicable state regulations.

Signature _____

Print / Typed Name _____

Date _____



WASTE MANAGEMENT
medwaste-wm.com

ROUTE NO: A311

TRUCK NUMBER

DOCUMENT #0000098270

MEDICAL WASTE TRACKING DOCUMENT
SERVICE DATE: 10/20/10

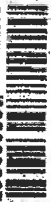

GENERATOR

| 2a. Description of Waste | 2b. Container Type | 2c. No. of Containers | 2d. lb. or Volume |
|--|--|-----------------------|-------------------|
| Regulated Medical Waste, N.O.S., 6.2 (UN 2981, PGII) | 31 GALLON (Regulated Medical Waste (RMW)) 31 gal | | |
| Regulated Medical Waste, N.O.S., 6.2 (UN 2981, PGII) | 49 GALLON (Regulated Medical Waste (RMW)) 49 gal | 7 | |
| TOTALS | | 7 | |

4. Transporter 1 is to check box if this is a through shipment

Transporter 1 Address: WM Healthcare Solutions, Inc.
1996 Don Lea Place Ste. C
Escondido, CA 92029

Transporter 1 Acknowledgement of Receipt of Materials

Signature: *[Signature]* Print / Typed Name: S. Kelly

Transporter 2 Address: Smith Systems Transportation
417 9th Ave, Scottsbluff, NE 69361
P.O. Box 2455, Scottsbluff, NE 69365

Transporter 2 Acknowledgement of Receipt of Materials

Signature: *[Signature]* Print / Typed Name: *[Name]*

Intermediate Handler 2 / Acknowledgement of Receipt of Materials

Signature: *[Signature]* Print / Typed Name: *[Name]*

Discrepancy / Comments

Discrepancy: *[Blank]*

Comments: *[Blank]*

TD terminated New TD # *[Blank]*

24-Hour Emergency Response (800) 424-9300

State Generator's ID No. *[Blank]*

Generator's US EPA ID No. *[Blank]*

Permit number: *[Blank]*

Date: 10-20-10

Signature: *[Signature]* Print Name: *[Name]*

Signature: *[Signature]* Print Name: *[Name]*

Signature: *[Signature]* Print Name: *[Name]*

3. Generator's Certification: I hereby declare that the contents of this consignment are fully and accurately described above by the proper shipping name and are classified, packaged, marked and labeled/carcared, and are in all respects in proper condition for transport by highway according to applicable international and national transportation regulations, including applicable state regulations.

Signature: *[Signature]* Print / Typed Name: *[Name]* Date: 10-20-10

White copy - Transporter/Collector Yellow copy - Treatment Facility Orange copy - Transfer Facility Pink copy - Generator/Collector

Incorrectly filled out Tracking Documents



WASTE MANAGEMENT
medwaste.wm.com

MEDICAL WASTE TRACKING DOCUMENT
SERVICE DATE: 02/26/2010

ROUTE NO. - V501 TRUCK NUMBER 424-9300 DOCUMENT #: 3483

24-Hour Emergency Response
(800) 424-9300

Generator's US EPA ID No. _____

State Generator's ID No. _____

Generator No: 000788001
13344 Clark St #118
Torrance, CA 91358-3585
(619) 691-5814
MOLLE CREW

| Seq | Description of Waste | 2b. Container Type | 2c. No. of Containers | 2d. Lb. or volume |
|---|--|--|-----------------------|-------------------|
| 1 | Regulated Medical Waste, NO.S. 6A, UN 297, POB | 51 GALLON (Regulated Medical Waste (RMW)) 31 gal | 1 | |
| 2 | Regulated Medical Waste, NO.S. 8 2A, UN 297, POB | 43 GALLON (Regulated Medical Waste (RMW)) 43 gal | 1 | |
| 3 | Regulated Medical Waste, NO.S. 6A, UN 297, POB | 86 GALLON (Regulated Medical Waste (RMW)) 86 gal | 1 | |
| TOTALS | | | | |
| 4. Transporter 1 is to check box if this is a through shipment <input type="checkbox"/> | | | | |

Transporter 1 Address: PERI Healthcare Solutions, Inc. Phone #: (800) 364-9553
3935 Conroy Ave, Ste. C
San Diego, CA 92129
 Transporter 1 Acknowledgement of Receipt of Materials
 Signature: [Signature] Print / Typed Name: Walter Date: 2/26/10

Transporter 2 Address: _____ Phone #: _____
 Intermediate Handler 2 / Acknowledgement of Receipt of Materials
 Signature: _____ Print / Typed Name: _____ Date: _____

Discrepancy / Comments: _____

7. Treatment Facility Printed Certification of Receipt and Treatment
 I certify that the contents of the listed containers have been received, treated and disposed of in accordance with all local, state, and federal regulations, including applicable state regulations.
 Signature: _____ Print / Typed Name: _____

3. Generator's Certification: I hereby declare that the contents of this consignment are fully and accurately described above by the proper shipping name and are classified, packaged, marked and labeled, placarded, and are in all respects in proper condition for transport by highway according to applicable international and national government regulations, including applicable state regulations.

Signatures: _____ Print / Typed Name: _____ Date: _____

White copy - Transporter/Collection Yellow copy - Treatment Facility Orange copy - Transfer Facility Pink copy - Generator/Customer



MEDICAL WASTE TRACKING DOCUMENT
 SERVICE DATE: 04/12/09
 TRUCK NUMBER

ROUTE NO. - 1101
 (800) 424-9300
 Generator's US EPA ID No.

| Seq | Generator No. | 2a. Description of Waste | 2b. Container Type | 2c. No of Containers | 2d. lb. or volume |
|-----|---------------|---|--|----------------------|-------------------|
| 1 | 0001020401 | Regulated Medical Waste, A.D. R.F. 1M, 20% DRI | 31 GALLON (Regulated Medical Waste (RMW)) 31 gal | 1 | 30# |
| | | Regulated medical waste, N.O.S., R.F. 1M, 20% DRI | 45 GALLON (Regulated Medical Waste (RMW)) 45 gal | 1 | 30# |
| | | TOTALS | | | |
| | | 30# | | | |

Generator 1

Generator 1 Address: NM Healthcare Solutions, Inc.
 1986 Don Lee Place Ste. C
 Escondido, CA 92029
 Phone #: (800) 354-0693

Signature: *[Signature]* Date: 4/12/09

Part / Typed Name: *[Signature]*

Applicable permit number: MW-157, 5688

7. Treatment Facility Printed Certification of Receipt and Treatment
 I certify that the contents of the listed containers have been received, weighed and disposed of in accordance with all local, state, and federal regulations. Print Name, Authorized Signature, and Applicable Dates in space provided below.

Signature: *[Signature]* Date: 4/12/09

7a. Autoclave Facility: Millum Textile Services, 3152 N 34th Dr, Phoenix, AZ 85007, Phone: (602) 895-5108, Permit #: PR004-076

7b. Transfer Facility: WM Healthcare Solutions, Inc., 1986 Don Lee Place, Suite C, Escondido, CA 92029, Phone: (760) 489-5099, Permit #: TS-73

7c. Incineration Facility: WMRRC, 7508 State Hwy 65, Anaheim, TX 77614, (909) 267-3013, Permit #: MSW 2239-A

7d. Autoclave Facility: Waste Management, 1300 E. Contrerasa Row, Reno, NV 89512, (775) 326-2403, Permit #: MSWL-003, WPH-004

7e. Alternate Facility:

3. Generator's Certification: I hereby declare that the contents of this shipment are fully and accurately described above by the proper shipping name and are classified, packaged, marked and labeled/placarded, and are in all respects in proper condition for transport by highway according to applicable international and national government regulations, including applicable state regulations.

Signature: *[Signature]* Print / Typed Name: *[Name]* Date: 4/12/09

White copy - Transporter/Collection Yellow copy - Treatment Facility Orange copy - Transfer Facility Pink copy - Generator/Customer



WASTE MANAGEMENT
medwaste.wmm.com

ROUTE NO. PH201

TRUCK NUMBER

MEDICAL WASTE TRACKING DOCUMENT
SERVICE DATE: 10/26/2010

DOCUMENT #: 0000109468

Generator No. 894-2300001
Generator Name: BAYADA NURSES
554-2300001
706 E Bell Rd #101
Phoenix, AZ 85022-9841
(602) 870-8364

24-Hour Emergency Response
(800) 424-9300
State Generator's ID No.
Generator's US EPA ID No.

GENERATOR

| Seq | Description of Waste Regulated Medical Waste, RCRA 9, 6.2 UN 329, PSII | 2b. Container Type | 2c. No of Containers | 2d. lb. or Volume |
|---------------|--|--------------------|----------------------|-------------------|
| 1 | GALLON (Regulated Medical Waste (RMW)) 42 gal | | 1 | 25lb5 |
| TOTALS | | | 1 | 25lb5 |

Transporter 1
Transporter 1 Address: WMM Healthcare Solutions, Inc.
3152 N 34th Dr
Phoenix, AZ 85017
Phone #: (760) 489-5009

Applicable permit numbers: TR090904.00
Signature: Jane Doe
Print / Typed Name: Jane Y. Doe
Date: 10-26-10

Transporter 2 / Intermediate Handler
Signature: _____
Print / Typed Name: _____
Permit number: _____
Date: _____

Discrepancy / Comments
TD terminated New TD # _____
Signature: _____
Date: _____

7. Treatment Facility Printed Certification of Receipt and Treatment
I certify that the contents of the listed containers have been received, treated and disposed of in accordance with all local, state and federal regulations.
Signature: _____
Date: _____

3. Generator's Certification: "I hereby declare that the contents of this consignment are fully and accurately described above by the proper shipping name and are classified, packaged, marked and labeled/placarded, and are in all respects in proper condition for transport by highway according to applicable international and national government regulations, including applicable state regulations."

Signature _____ Print / Typed Name _____ Date _____
White copy - Transporter/Collection Yellow copy - Treatment Facility Orange copy - Transfer Facility Pink copy - Generator/Customer

STAMP



WASTE MANAGEMENT
medwaste.wm.com

ROUTE NO. -BAY

TRUCK NUMBER

MEDICAL WASTE TRACKING DOCUMENT
SERVICE DATE: 10/29/2010

DOCUMENT #: 0000108452

GENERATOR

| | | | |
|-----|--|--------------------------|---|
| Seq | Generator No. | BAY-870001 | 24-Hour Emergency Response (800) 424-9300 |
| 1 | BRIDGE FAMILY PRACTICE BAY-870001 5900 Shattuck Ave #101 Oakland, CA 94608-1491 (510) 585-1500 | State Generator's ID No. | Generator's US EPA ID No. |

| 2a. Description of Waste | 2b. Container Type | 2c. No of Containers | 2d. lb. or Volume |
|--|--|----------------------|-------------------|
| Regulated Medical Waste, MD S, 6? UM 3291, PGI# | 31 GALLON (Regulated Medical Waste (Bio)) 31 gal | 2 | 100lbs |
| TOTALS | | | |
| | | 2 | 100lbs |

4. Transporter 1 is to check box if this is a through shipment

Transporter 1 Address: WM Healthcare Solutions, Inc.
1995 Don Lee Place Ste. C
Escondido, CA 92029

Transporter 1 Acknowledgement of Receipt of Materials

Signature _____ Print / Typed Name _____ Date _____

Applicable permit numbers: Escondido- 5688 - MW-172 Phone #: (760) 489-5009
Vernon- 9688 - MW-157 Phone #: (323) 367-0514

5. Transporter 2 / Intermediate Handler Address: Smith Systems Transportation
417 9th Ave, Scottsbluff, NE 69361 Phone #: (800) 897-5571
P.O. Box 2455, Scottsbluff, NE 69363

Intermediate Handler 2 / Acknowledgement of Receipt of Materials

Signature _____ Print / Typed Name _____ Date _____

Permit number: _____

Discrepancy / Comments

TD terminated New TD # _____

Signature _____ Date _____

7A. Transfer Facility:
Waste Handler:
3870 Enterprise Ave.
Hayward, CA 94545
Phone (708) 249-5009
Permit #: TS-96
Signature: MB
Date: 10/29/10

7B. Transfer Facility:
WM Healthcare Solutions, Inc.
1995 Don Lee Place Ste. C
Escondido, CA 92029
Phone (760) 489-5009
Permit #: TS-73
Signature: _____
Date: _____

7C. Incineration Facility:
VMRRRC
7505 State Hwy 66
Auburquerque, TX 77516
Phone (409) 257-5915
Permit #: MSW 2229-A-1

7D. Autoclave Facility:
Waste Management
1380 E Commercial Row
Meriden, NV 29952
Phone (773) 328-2409
Permit #: MSW-005
IN-4002

7E. Alternate Facility:
WM Healthcare Solutions
4280 Grand Blvd
Perth, CA 90005
Phone (323) 367-0514
Permit #: 190CS-91
Signature: _____
Date: _____

3. Generator's Certification: "I hereby declare that the contents of this consignment are fully and accurately described above by the proper shipping name and are classified, packaged, marked and labeled/placarded, and are in all respects in proper condition for transport by highway according to applicable international and national government regulations, including applicable state regulations."

Signature _____ Print / Typed Name _____ Date _____
White copy - Transporter/Collection Yellow copy - Treatment Facility Orange copy - Transfer Facility Pink copy - Generator/Customer

Correctly Completed Tracking Document



WASTE MANAGEMENT
REGULATED WASTE COLLECTION

MEDICAL WASTE TRACKING DOCUMENT
SERVICE DATE: 08/29/2010
TRUCK NUMBER: 24-Hour Emergency Response (800) 424-9300
DOCUMENT #0000031572

Generator No: **783-7001** ROUTE NO: **E201**
783-7001
5020 Children's Way
San Diego, CA 92123-4223
(658) 988-5841

Generator's US EPA ID No. _____

| 1a. Description of Waste | 2a. Container Type | 2b. No. of Containers | 2c. Lb. or Volume |
|--------------------------------------|---|-----------------------|-------------------|
| Regulated Infectious Waste (Bio), 12 | 20 GALLON BOX CUSTOMER (Regulated Medical Waste (Bio)) | | |
| UN 281, 69 | 20 gal | | |
| Regulated Infectious Waste (Bio), 49 | 31 GALLON (Regulated Medical Waste (Bio)) | | |
| UN 281, 69 | 31 gal | | |
| Regulated Medical Waste (Bio), 72 | 43 GALLON (Regulated Medical Waste (Bio)) | | |
| UN 281, 69 | 43 gal | | |
| Regulated Medical Waste (Bio), 63 | 44 GALLON (Regulated Medical Waste (Bio)) | | |
| UN 281, 69 | 44 gal | | |
| Regulated Medical Waste (Bio), 63 | BD Sharps container recycling (Regulated Medical Waste (Bio)) | | |
| UN 281, 69 | gal | | |
| TOTALS | | 42 | 1,557 lb |

1b. Transfer Facility:
 WASTE MANAGEMENT
 1898 Don Lee Pines Sulin C
 Escondido, CA 92029
 Phone (760) 488-5009
 Permit #: TS-73
 Signature: _____ Date: 8/29/10

1c. Incineration Facility:
 WARRICK
 7505 State Hwy 65
 Amarillo, TX 79134
 Phone (806) 267-8593
 Permit #: WSV 22954

1d. Autoclave Facility:
 7B. Autoclave Facility:
 Waste Management
 1380 E Commercial Row
 Reno, NV 89512
 Phone (775) 785-2409
 Permit #: MSVL-003
 IWH-004

1e. Alternate Facility:
 7E. Alternate Facility:
 WTS
 3152 N 34th Dr
 Phoenix, AZ 85007
 Phone (602) 696-6108
 Permit #: PH-004-076

2d. Treatment Facility: Printed Certification of Receipt and Treatment and/or disposed of in accordance with all local, state, and federal regulations.
 Print Name: _____ Date: 8-23-10

3. Generator's Certification: I hereby declare that the contents of this consignment are fully and accurately described above by the proper shipping name and are classified, packaged, marked and labeled, packaged and are in all respects in proper condition for transport by highway according to applicable international and national government regulations, including applicable state regulations.
 Signature: _____ Print / Typed Name: Randy Veenstra Date: 8-3-10

4. Discrepancy / Comments: _____

5. Transporter 2 / Intermediate Handler: _____

6. Transporter 1: _____

7. Signature: _____ Date: _____

Step 1: Enter quantity of Containers.



MEDICAL WASTE TRACKING DOCUMENT
 SERVICE DATE: 01/27/2011
 TRUCK NUMBER
 (800) 424-9300

WASTE MANAGEMENT
 MEDICAL WASTE WTR-COM
 ROUTE NO. - ESC Gate
 24-Hour Emergency Response
 State Generator's ID No.
 Generator's US EPA ID No.

Generator No: 783-235001
 Generator Name: CLEAN HARBORS MASTER
 Generator Address: 12 Longwater Dr, Norwell, MA 02061-1812

| 2a. Description of Waste | 2b. Container Type | 2c. No. of Containers | 2d. lb. or Volume |
|--|--|-----------------------|-------------------|
| Regulated Medical Waste, N.O.S., 6.R UN 3291, P01 | 31 GALLON (Regulated Medical Waste (RMW)) 31 gal | 4 | |
| Regulated Medical Waste, N.O.S., 6.R UN 3291, P01 | 43 GALLON (Regulated Medical Waste (RMW)) 43 gal | 10 | |
| Regulated Medical Waste, N.O.S., 6.R UN 3291, P01 | 98 GALLON (Regulated Medical Waste (RMW)) 98 gal | 2 | |
| TOTALS | | | |

3. Generator's Certification: I hereby declare that the contents of this consignment are fully and accurately described above by the proper shipping name and are classified, packaged, marked and labeled/placarded, and are in all respects in proper condition for transport by highway according to applicable international and national government regulations, including applicable state regulations.

4. Transporter 1 is to check box if this is a through shipment Applicable permit number: _____

5. Transporter 1 Address: WM Healthcare Solutions, Inc.
 1385 Don Lee Plaza Ste. C
 Escanudo, CA 92029
 Phone #: (760) 489-5009
 Fax #: (760) 489-5009
 Permit #: NSWL-003

6. Transporter 2 / Intermediate Handler
 Signature: _____ Date: _____
 Print / Typed Name: _____
 Phone #: _____
 Fax #: _____
 Permit number: _____

7. Treatment Facility Printed Certification of Receipt and Treatment and disposal of in accordance with all local, state, and federal regulations.
 Signature: _____ Date: _____
 Print Name: _____
 Phone #: _____
 Fax #: _____
 Permit #: _____

8. Discrepancy / Comments: _____
 10 terminated New TD # _____

9. Signature: _____ Date: _____
 White copy - Transporter/Collection Yellow copy - Treatment Facility Orange copy - Transfer Facility Pink copy - Generator/Customer

Step 2: Enter volume for each size and waste.



WASTE MANAGEMENT
medwaste.wm.com

ROUTE No. - ESC Gate
TRUCK NUMBER
SERVICE DATE: 01/27/2011

MEDICAL WASTE TRACKING DOCUMENT
24-Hour Emergency/Response
(800) 424-9300

Document #: 0000136250

| Seq | Generator Info | 2a. Description of Waste | 2b. Container Type | 2c. No. of Containers | 2d. Net Volume | 2e. Net Weight |
|---------------|---|--|--------------------|-----------------------|----------------|----------------|
| 1 | CLEAN HARBORS MASTER 793 235001 42 Longwater Dr Northwell, WA 02061-1612 | 31 GALLON (Regulated Medical Waste) (Bio) 91 gal | | 4 | 124 gals | |
| | | 43 GALLON (Regulated Medical Waste) (Bio) 43 gal | | 10 | 430 gals | |
| | | 95 GALLON (Regulated Medical Waste) (Bio) 95 gal | | 2 | 192 gals | |
| TOTALS | | | | | | |

Generator 1:
 WMI Healthcare Solutions, Inc.
 1390 E Commercial Row
 Reno, NV 89512
 Phone: (775) 326-2409
 Permit #: MSW-003
 WVI-004

Generator 2:
 WMI Healthcare Solutions
 1390 E Commercial Row
 Reno, NV 89512
 Phone: (775) 326-2409
 Permit #: MSW-003
 WVI-004

Transporter 1:
 WMI Healthcare Solutions, Inc.
 1390 E Commercial Row
 Reno, NV 89512
 Phone: (775) 326-2409
 Permit #: MSW-003
 WVI-004

Transporter 2:
 WMI Healthcare Solutions
 1390 E Commercial Row
 Reno, NV 89512
 Phone: (775) 326-2409
 Permit #: MSW-003
 WVI-004

Generator's Certification: I hereby declare that the contents of this consignment are fully and accurately described above by the proper shipping name and are classified, packaged, marked and labeled/manifested, and are in all respects in proper condition for transport by highway according to applicable International and national government regulations, including applicable state regulations.

Signature: _____ Print / Typed Name: _____ Date: _____

White copy - Transporter/Collection Yellow copy - Treatment Facility Orange copy - Transfer Facility Pink copy - Generator/Customer

Step 3: Total the Columns.



WASTE MANAGEMENT
WASTE MANAGEMENT, CORP.
ROUTE NO. -ESC Gate
TRUCK NUMBER
24-Hour Emergency Response
(800) 424-9300
Generator's ID No.
Generator's US EPA ID No.

Medical Waste Tracking Document
SERVICE DATE: 01/27/2011
DOCUMENT #: 0000136250

Generator No. 793-235001
 ACCOUNT 793-235001
 42 Longwater Dr
 Newport, WA 02061-1612

| 1a. Description of Waste | 2a. Container Type | 3a. No. of Containers | 3b. Vol. or Weight |
|--|--------------------|-----------------------|--------------------|
| 38 GALLON (Regulated Medical Waste (RMW)) 81 gal | | 4 | 124 gals |
| 48 GALLON (Regulated Medical Waste (RMW)) 48 gal | | 10 | 430 gals |
| 96 GALLON (Regulated Medical Waste (RMW)) 96 gal | | 2 | 192 gals |
| TOTALS | | 16 | 746 gals |

Transporter 1 Address: WVI Healthcare Solutions, Inc.
 1906 Don Lee Place Ste. C
 Escandido, CA 92029
 Phone #: (760) 489-5009
 Permit #: 68SW-003
 MH-004

Transporter 2 Address: WVI Healthcare Solutions, Inc.
 1906 Don Lee Place Ste. C
 Escandido, CA 92029
 Phone #: (760) 489-5009
 Permit #: 68SW-003
 MH-004

Generator's Certification: I hereby declare that the contents of this consignment are fully and accurately described above by the proper shipping name and are classified, packaged, marked and labeled/placarded, and are in all respects in proper condition for transport by highway according to applicable international and national government regulations, including applicable state regulations.

Signature: _____ Print / Typed Name: _____ Date: _____
 White copy - Transporter/Collection Yellow copy - Treatment Facility Orange copy - Transfer Facility Pink copy - Generator/Customer

Step 4: Indicate destination of the waste.



MEDICAL WASTE TRACKING DOCUMENT
 SERVICE DATE: 01/27/2011
 TRUCK NUMBER: _____
 DOCUMENT #: 0000336250

WASTE MANAGEMENT
 MEDICAL WASTE MANAGEMENT
 ROUTE NO. - ESC Gate

Generator No. 793-235001
 ACCOUNT 793-235001
 42 Longwater Dr.
 Newell, MA 02061-1612

Generator's ID No. _____
 Generator's US EPA ID No. _____

24-Hour Emergency Response
 (800) 424-9300

| 2a. Description of Waste | 2b. Container Type | 2c. No. of Containers | 2d. E. or Volume |
|---|--|-----------------------|------------------|
| Regulated Medical Waste, NO S, 6/2 UN 2811, POB | 31 GALLON (Regulated Medical Waste (RMO)) 31 gal | 4 | 124 gals |
| Regulated Infectious Waste, MO S, 6/2 UN 3281, POB | 43 GALLON (Regulated Medical Waste (RMO)) 43 gal | 10 | 430 gals |
| Regulated Anatomic Waste, NO S, 6/2 UN 3251, POB | 99 GALLON (Regulated Medical Waste (RMO)) 99 gal | 2 | 192 gals |
| TOTALS | | 16 | 746 gals |

4. Transporter 1 is to check box if this is a through shipment

Transporter 1 Address: **WM Healthcare Solutions, Inc.**
 1996 Don Lee Place Ste. C
 Escondido, CA 92029

Transporter 1 Acknowledgement of Receipt of Materials
 Signature: _____
 Print / Typed Name: _____

Transporter 2 / Intermediate Handler
 Signature: _____
 Print / Typed Name: _____
 Permit number: _____
 Date: _____

7. Treatment Facility Printed Certification of Receipt and Treatment and Disposed of in accordance with all local, state, and federal regulations.
 Print Name: _____
 Date: _____

3. Generator's Certification: I hereby declare that the contents of this consignment are fully and accurately described above by the proper shipping name and are classified, packaged, marked and labeled, placarded, and are in all respects in proper condition for transport by highway according to applicable international and national government regulations, including applicable state regulations.

Signature: _____ Print / Typed Name: _____ Date: _____
 White copy - Transporter/Collection Yellow copy - Treatment Facility Orange copy - Transfer Facility Pink copy - Generator/Customer

Step 5: Sign, and print your name. Enter date.



WASTE MANAGEMENT MEDICAL WASTE MANAGEMENT
 MEDICAL WASTE MANAGEMENT
 ROUTE NO. ESC Gate
 SERVICE DATE: 01/27/2011
 TRUCK NUMBER
 24-Hour Emergency Response
 (800) 424-9300
 Generator's ID No.
 Generator's US EPA ID No.
 DOCUMENT #: 0000136250

1. Generator No. 793-235001
 ACCOUNT
 793-235001
 42 Longwater Dr
 Norwell, MA 02061-1812

24-Hour Emergency Response
 (800) 424-9300

Generator's ID No.
 Generator's US EPA ID No.

WMA Healthcare Solutions:
 4280 Ranch Blvd
 Vernon, CA 90058
 Phone (323) 907-0857
 Permit #: TCS051 81

Signature: _____ Date: _____

| 2a. Description of Waste | 2b. Container Type | 2c. No of Containers | 2d. Volume |
|--|--|----------------------|----------------|
| Regulated Medical Waste, NOS, 6.2 UN 281, P01 | 31 GALLON (Regulated Medical Waste (Bio)) 31 gal | 4 | 124 gal |
| Regulated Medical Waste NOS, 6.2 UN 281, P01 | 43 GALLON (Regulated Medical Waste (Bio)) 43 gal | 10 | 430 gal |
| Regulated Medical Waste NOS, 6.2 UN 281, P01 | 98 GALLON (Regulated Medical Waste (Bio)) 98 gal | 2 | 192 gal |
| TOTALS | | 16 | 746 gal |

4. Transporter 1 is to check box if this is a through shipment

Transporter 1 Address: WMA Healthcare Solutions, Inc.
 1999
 Escorido, CA 90239

Transporter 1 Acknowledgement of Receipt of Materials
 Signature: Karen Walden Print / Typed Name: Karen Walden date: 1-27-11

Applicable permit numbers: Escorido-5888 - Jan 4/72
 Phone #: (720) 489-5009
 Vernon-5688 - (909) 517-0514
 Phone #: (323) 307-0514

WMA Healthcare Solutions:
 4280 Ranch Blvd
 Vernon, CA 90058
 Phone (323) 907-0857
 Permit #: TCS051 81

Signature: _____ Date: _____

5. Transporter 2 Address: _____ Phone #: _____

Intermediate Handler 2 / Acknowledgement of Receipt of Materials
 Signature: _____ Print / Typed Name: _____ date: _____

Permit number: _____

6. Discrepancy _____

Comments _____

Discrepancy / Comments _____

TD terminated New TD # _____

Signature _____ Date: _____

3. Generator's Certification: I hereby declare that the contents of this consignment are fully and accurately described above by the proper shipping name and are classified, packaged, marked and labeled/placarded, and are in all respects in proper condition for transport by highway according to applicable international and national government regulations, including applicable state regulations.

Signature _____ Print / Typed Name _____ Date _____

White copy - Transporter/Collection Yellow copy - Treatment Facility Orange copy - Transfer Facility Pink copy - Generator/Customer

Step 6: Customer prints, and Signs. Enters Date.



WASTE MANAGEMENT
MEDICAL WASTE TRACKING DOCUMENT
SERVICE DATE: 01/27/2011
TRUCK NUMBER
(800) 424-9300

ROUTE NO. - ESC Gate
24-Hour Emergency Response
Generator's US EPA ID No.

DOCUMENT #: 0000136250

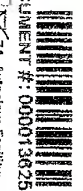

| 2a. Description of Waste | 2b. Container Type | 2c. No. of Containers | 2d. Lbs. or Volume | 2e. Generator's US EPA ID No. |
|--|--|-----------------------|--------------------|-------------------------------|
| Regulated Medical Waste, N.O.S., 6.2 UN 3291, PGH | 31 GALLON (Regulated Medical Waste (RMW)) 31 gal | 4 | 124 gals | |
| Regulated Medical Waste, N.O.S., 6.2 UN 3291, PGH | 43 GALLON (Regulated Medical Waste (RMW)) 43 gal | 10 | 430 gals | |
| Regulated Medical Waste, N.O.S., 6.2 UN 3291, PGH | 96 GALLON (Regulated Medical Waste (RMW)) 96 gal | 2 | 192 gals | |
| TOTALS | | 16 | 746 gals | |

7A. Autoclave Facility:
WMA Healthcare Solutions
4260 Denon Blvd
Pineville, LA 70454
Phone: (225) 302-6557
Permit #: TSCOST 81

7B. Transfer Facility:
WMA Healthcare Solutions
1906 Don Lee Place Suite C
Escalante, CA 92229
Phone: (760) 489-5009
Permit #: TS-73

7C. Incineration Facility:
WMA-PRC
7805 State Hwy/65
P.O. Box 17714
Phone: (405) 257-3915
Permit #: MSW 2239-A

7D. Alternative Facility:
Waste Management
1300 E Commercial Row
Reno, NV 89512
Phone: (775) 326-2409
Permit #: MSW 2403
131105A

7E. Alternate Facility:
WMA Healthcare Solutions
8152 N 34th Dr
Phoenix, AZ 85017
Phone: (760) 489-5009
Permit #: 070452 00

3. Generator's Certification: I hereby declare that the contents of this assignment are truly and accurately described above by the proper shipping name and are classified, packaged, marked and labeled/loaded, and are in all respects in proper condition for transport by highway according to applicable international and national government regulations, including applicable state regulations.

Signature: Customer Signs Print / Typed Name: Customer Prints Date: 1-27-11

White copy - Transporter/Collection Yellow copy - Treatment Facility Orange copy - Transfer Facility Pink copy - Generator/Customer

Step 7: Sign and Date when delivered to Facility.



WASTE MANAGEMENT
MEDWASTE-WMT-COM

MEDICAL WASTE TRACKING DOCUMENT
 SERVICE DATE: 01/27/2011
 TRUCK NUMBER: **800) 424-9300**
 ROUTE NO. - ESC Gate
 DOCUMENT #: 0000438250

Generator No. **783-235001**
 Generator Name: **CLEAN HARBORS MASTER ACCOUNT**
 783 235001
 42 Longwater Dr
 Norwell, MA 02061-1812

Generator's US EPA ID No. _____
 State Generator's ID No. _____
 24-Hour Emergency/Response (800) 424-9300

| 2a. Description of Waste | 2b. Container Type | 2c. No of Containers | 2d. lb. or Volume |
|--|--|----------------------|-------------------|
| Regulated Infectious Waste (RIW) N.O.S. 6.2 UN 2821, PSN | 31 GALLON (Regulated Medical Waste (RMW)) 31 gal | 4 | 124 gals |
| Regulated Medical Waste (RMW) N.O.S. 6.2 UN 2821, PSN | 43 GALLON (Regulated Medical Waste (RMW)) 43 gal | 10 | 430 gals |
| Regulated Medical Waste (RMW) N.O.S. 1.7 UN 2821, PSN | 38 GALLON (Regulated Medical Waste (RMW)) 38 gal | 2 | 192 gals |
| TOTALS | | 16 | 746 gals |

Transporter 1 Address: **WMI Healthcare Solutions, Inc.**
 1996 Don Lee Place Ste. C
 Escondido, CA 92029
 Phone #: (760) 489-5009
 Fax #: (760) 489-5009
 Permit #: MSW 2239-A

Transporter 1 Acknowledgement of Receipt of Materials
 Signature: *Karyn Warden* Print / Typed Name: **Karyn Warden** Date: **1-27-11**

Transporter 2 / Intermediate Handler
 Signature: _____ Print / Typed Name: _____
 Signature: _____ Print / Typed Name: _____

7. Treatment Facility Printed Certification of Receipt and Treatment
 Signature: _____ Date: _____

3. Generator's Certification: I hereby declare that the contents of this consignment are fully and accurately described above by the proper shipping name and are classified, packaged, marked and labeled/sharps, and are in all respects in proper condition for transport by highway according to applicable international and national government regulations, including applicable state regulations.

Signature: *Customer Signs* Print / Typed Name: **Customer Prints** Date: **1-27-11**

White copy - Transporter/Collection Yellow copy - Treatment Facility Orange copy - Transfer Facility Pink copy - Generator/Customer

Important

- Medical waste must have a tracking system.
- Medical waste can only be taken to permitted transfer stations and treatment facilities.
- Tracking documents must be filled out correctly and transported with the medical waste.

Supply Bill Of Landing - Completed

STRAIGHT BILL OF LADING



Date: 1/25/2011
 P.O. No.
 Shipper No. WMH2011ESC-073
 Page 1 of 1
 WASTE MANAGEMENT

Shipped From: WM Healthcare Solutions
 1996 Don Lee Place, Suite C
 Escondido, CA 92029
 760-489-5009

Shipped To: WMSG Orange County
 31896 Plaza Dr
 San Juan Capistrano, CA 92675
 949-201-4100
 Jackie Salas

| Qty | HM | Kind of Packaging, Description of Articles, Special Marks and Exceptions | Vehicle No. | Customer No. | Class | Weight (lb) |
|-----|----|--|-------------|--------------|-------|-------------|
| 6 | | 3 Gallon Bio Sharps Containers | 783-332001 | | | |
| | | | | | | |
| | | | | | | |
| | | | | | | |
| | | | | | | |

Bill Freight Charge to: WM Healthcare Solutions
 Billing Address: 1996 Don Lee Place, Suite C
 City, State, Zip: Escondido, CA, 92029

COO Amount: COO Paid: Prepaid Collect: Freight Charges: Prepaid Collect:
 Is C-Station? Check Acceptable for COO? Yes No Check No

Shipper: WM Healthcare Solutions
 Authorized Signature: Date: 1/25/2011
 Receiver By: Laura Primm
 Authorized Signature: Date: 1/25/2011
 Print Name: Nelson Quintero

(Faint background text containing legal terms and conditions, including 'This is a copy of a bill of lading...' and 'The carrier is not responsible for...')

Autoclave Bill Of Lading - Blank

STRAIGHT BILL OF LADING & Medical Waste Tracking Document

| Date: | PO No. | Shipment: VERNWMHS2011- | Page 1 of 1 | | |
|--|---------------|---|--|---|--------------|
| Shipped from: Waste Management Healthcare Solutions 1996 Don Lee Pl, Ste C Escondido, Ca, 92029 Permit: TS-73 | | Shipped To: WM Healthcare Solutions 4280 Bandini Blvd. Vernon, CA 91058 Permit: TSOST 81 | | | |
| Contact: David Curnow Phone: 760-489-5009 or 760-317-6261 | | Contact: Esperanza Duran Phone: 323-307-0514 | | | |
| Route | Tally Sheets: | Received by: WM Healthcare Solutions, For Treatment by Autoclave and Disposal. | | | |
| Dates: | | By: | Date: | | |
| Qty. | HM | Kind of Packaging, Description of Articles, Special Marks and Exemptions | | Class | Weight (lb.) |
| | | Biohazardous Waste for Autoclaving: | | | |
| | | 20 gallon, Tubbs & Sharps Containers | | | |
| | | UN3291, Regulated Medical Waste, n.o.s., 6.2, PG II | | | |
| | | Biohazardous Waste for Autoclaving: | | | |
| | | 31 gallon, Tubbs & Sharps Containers | | | |
| | | UN3291, Regulated Medical Waste, n.o.s., 6.2, PG II | | | |
| | | Biohazardous Waste for Autoclaving: | | | |
| | | 96 gallon Toters | | | |
| | | UN3291, Regulated Medical Waste, n.o.s., 6.2, PG II | | | |
| | | Biohazardous Waste for Autoclaving: | | | |
| | | 43 gallon, Tubbs & Sharps Containers | | | |
| | | UN3291, Regulated Medical Waste, n.o.s., 6.2, PG II | | | |
| | | Loose Pieces | | | |
| | | Pallets still to combine | | | |
| Bill Freight Charge to: Waste Management Healthcare Solutions Billing Address: 1996 Don Lee Pl, Suite C City, State, Zip: Escondido, CA, 92029 | | COD Fee: <input type="checkbox"/> Prepaid <input type="checkbox"/> Collected Is Customer Check Acceptable for COD? <input type="checkbox"/> Yes <input type="checkbox"/> No <input type="checkbox"/> Check No. | | Freight Charges: J Prepaid L Collected | |
| Shipped to: WM Healthcare Solutions, Inc. 1996 Don Lee Pl, Suite C Escondido, CA 92029 Permit: TS-73 | | | | | |
| Carrier: WM Healthcare Solutions, Inc. 1996 Don Lee Pl, Suite C Escondido, CA 92029 Permit: 5583 MW-172 | | | | | |
| Shipper: WM Healthcare Solutions, Inc. 1996 Don Lee Pl, Suite C Escondido, CA 92029 760-489-5009 Permit: TS-73 | | | Carrier: WM Healthcare Solutions, Inc. 1996 Don Lee Pl, Suite C Escondido, CA 92029 760-489-5009 Permit: 5583 MW-172 | | |
| Authorizer Signature: Date: | | | Authorizer Signature: Date: | | |
| Print Name: | | | Print Name: | | |

This bill of lading is subject to the terms and conditions of the contract between the shipper and the carrier, and the carrier's liability is limited to the actual value of the goods at the time of shipment. The shipper warrants that the goods are as described and that they conform to the applicable regulations. The carrier warrants that the goods are delivered in the same condition as received, unless otherwise indicated. This bill of lading is not a receipt for the goods and does not constitute an admission of liability. The shipper is responsible for obtaining all necessary permits and licenses for the transport of the goods. The carrier is not responsible for any damage to or loss of the goods during transport, unless it is caused by the carrier's negligence. The shipper is responsible for the accuracy of the information provided on this bill of lading. The carrier is not responsible for any delay in the delivery of the goods. The shipper is responsible for the payment of the freight charges. The carrier is not responsible for any customs duties or taxes. The shipper is responsible for the completion of all required paperwork. The carrier is not responsible for any loss of or damage to the bill of lading. The shipper is responsible for the return of the bill of lading to the carrier. The carrier is not responsible for any loss of or damage to the bill of lading. The shipper is responsible for the payment of the freight charges. The carrier is not responsible for any customs duties or taxes. The shipper is responsible for the completion of all required paperwork. The carrier is not responsible for any loss of or damage to the bill of lading.

Autoclave Bill Of Lading - Completed

STRAIGHT BILL OF LADING & Medical Waste Tracking Document

| | | | | |
|--|----------|--|-------------|-------------|
| Date: 1-20-11 | P.O. No. | Shipment: VERWWMHS2011-006 | Page 1 of 1 | |
| Shipped From: Waste Management Healthcare Solutions 1996 Don Lee Pl, Ste C Escondido, Ca. 92029 Permit: TS-73 | | Shipped To: WM Healthcare Solutions 4280 Bannini Blvd. Vernon, CA 90058 Permit: TS/OST 81 | | |
| Contact: David Cunrow 760-317-6261 or 760-489-5009 | | Contact: Esperanza Duran 323-307-0514 | | |
| Route: Tally Sheets: A10-1-38 through A10-142 Dates: 1/17/10 through 1/18/2011 | | | | |
| Received by: WM Healthcare Solutions For: (Resigner) by Autoclaving and disposal. | | Date: 1-20-11 | | |
| Qty | HM | Kind of Packaging, Description of Article, Special Marks and Expenditure | Class | Weight (lb) |
| 0 | | Biohazardous Waste for Autoclaving: 20 gallon, Tubes & Sharps Containers UN3291, Regulated Medical Waste, n.o.s., 6.2, PG I | | 0 EST. |
| 4 | | Biohazardous Waste for Autoclaving: 31 gallon, Tubes & Sharps Containers UN3291, Regulated Medical Waste, n.o.s., 6.2, PG II | | 100 EST. |
| 0 | | Biohazardous Waste for Autoclaving: 96 gallon Toters UN3291, Regulated Medical Waste, n.o.s., 6.2, PG II | | 0 EST. |
| 30 | | Biohazardous Waste for Autoclaving: 43 gallon, Tubes & Sharps Containers UN3291, Regulated Medical Waste, n.o.s., 6.2, PG II | | 2,800 EST. |
| Loose Pieces Carriage COD Amount: | | | | |
| Bill Freight Charge to: Waste Management Healthcare Solutions Mailing Address: 1996 Don Lee Pl, Suite C Escondido, CA 92029 | | COD Fee: <input type="checkbox"/> Prepaid <input type="checkbox"/> Collect Is Customer Check Acceptable for COD? <input type="checkbox"/> Yes <input type="checkbox"/> No Check No. | | |
| For a complete list of hazardous materials, please refer to the Department of Transportation Hazardous Materials Table, 49 CFR 173.13. | | Freight Charges: <input type="checkbox"/> Prepaid <input type="checkbox"/> Collect | | |

Shipper:
 WM Healthcare Solutions, Inc.
 1996 Don Lee Place, Suite C
 Escondido, Ca. 92029
 760-489-5009

Carrier:
 WM Healthcare Solutions, Inc.
 1996 Don Lee Place Suite C
 Escondido, CA 92029
 760-489-5009
 Permit: 56689 MW-172

Authorized Signature: *Kayn Walden*
 Date: 1-20-11
 Print Name: Kayn Walden

Authorized Signature: *[Signature]*
 Date: 1-20-11
 Print Name: Junior Cortez

Incineration Bill Of Lading - Blank

STRAIGHT BILL OF LADING & Medical Waste Tracking Document

| | | | | |
|--|----|--|----------------|-----------------------|
| Date: | | P.O. No: | Shipment: WMHS | Page 1 of 1 |
| Shipped From: Waste Management Healthcare Solutions 1996 Don Lee Pl, Ste C Escondido, Ca. 92029 Permit: TS-73 | | Shipped To: Waste Management Healthcare Solutions WM RRRC 7505 State Highway 65 Anahuac, TX 77514 Phn.: 409-267-3913 ext: 108 Fax: 409-267-3756 Attn: Jessica Granger MSW-2239A CN6034024704-RN100922392 | | |
| Contact: David Cumrow Phone: 760-317-6261 or 760-489-5009 | | Received by: WMRRRC For Incineration: | | |
| Route: | | Dates: | | |
| Qty: | HM | Kind of Packaging, Description of Articles, Special Marks and Exceptions | Date: | Weight (lb) |
| | | UN3291, Regulated Medical Waste, n.o.s., 6.2, PG II | | |
| | | Biohazardous Waste for Incineration - Chemotherapy (Trace) | | |
| | | UN3291, Regulated Medical Waste, n.o.s., 6.2, PG II | | |
| | | Biohazardous Waste for Incineration - Pathological Waste (REUSABLE TUBS) | | |
| | | UN3291, Regulated Medical Waste, n.o.s., 6.2, PG II | | |
| | | Pharmaceutical products for Incineration | | |
| | | UN3291, Regulated Medical Waste for Incineration - Biohazardous Waste | | |
| Loose Pieces | | Patients said to contain | COO Amount | COO Fee |
| Bill Freight Charge to: | | Waste Management Healthcare Solutions | By Customer | Check, Accrueable for |
| Mailing Address: | | 1991 Don Lee Pl, Ste C | COO? | Prepaid Collect |
| CN, State, Zip: | | Escondido, Ca. 92029 | Yes | No |
| | | | Check No. | |

This is to certify that the above named materials are properly packaged, labeled, marked, and stored in accordance with the applicable regulations of the Department of Transportation.

Receiver's Name: Waste Management Healthcare Solutions, 1996 Don Lee Pl, Ste C, Escondido, CA 92029. The receiver hereby certifies that the material is in conformity with the applicable regulations of the Department of Transportation and that the material is properly packaged, labeled, marked, and stored in accordance with the applicable regulations of the Department of Transportation.

Shipper's Name: Waste Management Healthcare Solutions, 1996 Don Lee Pl, Ste C, Escondido, CA 92029. The shipper hereby certifies that the material is in conformity with the applicable regulations of the Department of Transportation and that the material is properly packaged, labeled, marked, and stored in accordance with the applicable regulations of the Department of Transportation.

Suppose hereby certifies that the material is in conformity with the applicable regulations of the Department of Transportation and that the material is properly packaged, labeled, marked, and stored in accordance with the applicable regulations of the Department of Transportation.

| | |
|---|--|
| Shipper: Waste Management Healthcare Solutions 1996 Don Lee Pl, Ste C Escondido, Ca. 92029 760-489-5009 Permit: TS-73 | Carrier: Smith Systems 417 4th Ave P.O. Box 2455 Scottsbluff, Ne 68963 308-632-5148 Ca. Hauler # 3405 TCEQ Permit Number MSW-500988 |
| Authorized Signature: Date: | Authorized Signature: Date: |
| Print Name: | Print Name: |

Incineration Bill Of Lading - Completed

STRAIGHT BILL OF LADING & Medical Waste Tracking Document

Date: 1/11/11 P.O. No. Shipment: WMHS 51 Page 1 of 1

Shipped from:
 Waste Management Healthcare Solutions
 1996 Don Lee Pl, Ste C
 Escondido, Ca. 92029
 TS-73

Shipped To:
 Waste Management Healthcare Solutions
 WMI RRRRC
 7795 State Highway 65
 Anaheim, TX 77514
 P.O. Box 309-567-3993 ext 108
 Attn: Jessica Grogan

Contact: David Cumrow 760-317-6261
 or 760-489-5009

MSW-2239A
 CN6034024704-RN100922392

Route Dates: 12/15/10 to 12/23/10

Received by: WMRRRC
 For Incineration

By: Date:

| Qty | HW | Kind of Packaging, Description of Article, Special Marks and Exceptions | Class | Weight (lb.) |
|-----|----|--|-------|--------------|
| 12 | | Biohazardous Waste for Incineration - Chemotherapy (Trace) UN3291, Regulated Medical Waste, n.o.s., 6.2, PG II | | 2,383 |
| | | Biohazardous Waste for Incineration - Pathological Waste (REUSABLE TUBS) UN3291, Regulated Medical Waste, n.o.s., 6.2, PG II | | |
| 8 | | Pharmaceutical products for Incineration Regulated Medical Waste for Incineration - Biohazardous Waste UN3291, Regulated Medical Waste, n.o.s., 6.2, PG II | | 3,399 |

Loose Pieces: Pieces sealed to contain
 Bill Freight Charge to: Waste Management Healthcare Solutions
 Rating Address: 1996 Don Lee Pl, Ste C
 City, State, Zip: Escondido, Ca. 92029

COB Amount: COD Fee: Prepaid Collect
 Is Customer Check Acceptable:
 COO? YES NO Check No. _____
 The carrier and its service provider are hereby indemnified against all claims, damages, and expenses, including reasonable attorney's fees, arising out of or from the transportation of the goods herein, whether or not such claims, damages, and expenses are caused in whole or in part by the negligence of the carrier or its service provider. This bill of lading is subject to the terms and conditions of the carrier's tariff, which are hereby incorporated by reference into this bill of lading. The carrier's tariff is available at the carrier's office or at the following website: www.waste.com. The carrier's tariff is hereby accepted by the shipper and consignee. The carrier's tariff is hereby accepted by the shipper and consignee.

Shipper:
 Waste Management Healthcare Solutions
 1996 Don Lee Pl, Ste C
 Escondido, Ca. 92029
 760-489-5009

Carrier: Smith Systems
 417 9th Ave
 P.O. Box 2455
 Southfield, Ne 89363
 308-692-5148
 Ca. Hwy 67 # 3408
 TCEQ Permit Number: MSW-50085

Authorized Signatures:
 Shipper: [Signature] Carrier: [Signature]
 Print Name: David Cumrow Print Name: Bill Casack



DOT MEDICAL WASTE COLLECTION AND TRANSPORTATION

Presented by
WM Healthcare Solutions, Inc.
2010



THINK GREEN®

Follow along with the training

Following this presentation I would like to recap with a few questions concerning the proper handling of medical waste. The questions will be given in a multiple choice format and will allow you to further educate yourself on matters of concern in the Regulated Medical waste arena. Thank you in advance for your attention to this topic.

Copies of this training will be made available to you following the presentation .



THINK GREEN®

Who is the DOT??

The Department of Transportation (DOT), a cabinet-level executive department of the United States government, develops and coordinates policies that will provide an efficient and economical national transportation system, with due regard for need, the environment, and national defense.



Who is the DOT??

The DOT is responsible for the protection of public safety in all areas of transportation in the United States. As a consequence of the DOT mandate for public safety in transportation, DOT regulation specifies how hazardous materials are *prepared, packaged and transported*.

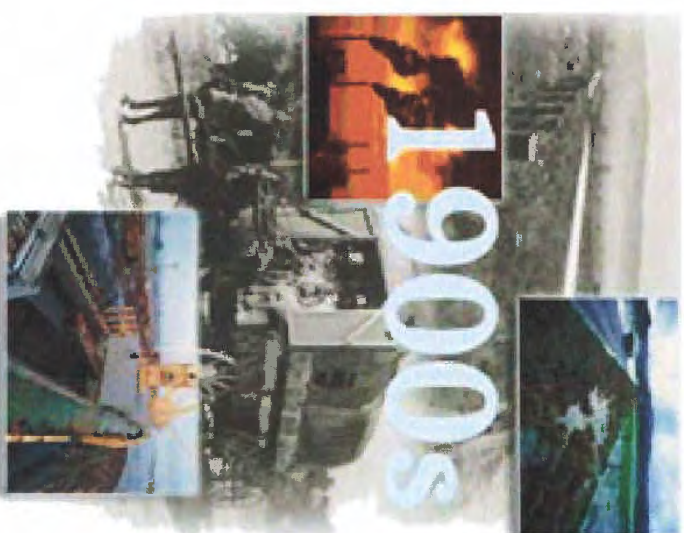

THINK GREEN®

Who is the DOT??

As the DOT acts as the government watchdog, each state has its own department of transportation that manages its system of highways and roadways.

Any regulations that an individual state would enact would only enhance above and beyond the effectiveness of the standard U.S. DOT regulations.



THINK GREEN.®

Other Agencies operating under DOT



THINK GREEN®

PHMSA??

As one of ten agencies within the U.S. DOT, Pipeline and Hazardous Materials Safety Administration (PHMSA) works to protect the American public and the environment by ensuring the safe and secure movement of hazardous materials to industry and consumers by all transportation modes, including the nation's

P PHMSA's mission is to protect people and the environment from the risks inherent in transportation of hazardous materials - by pipeline and other modes of transportation.

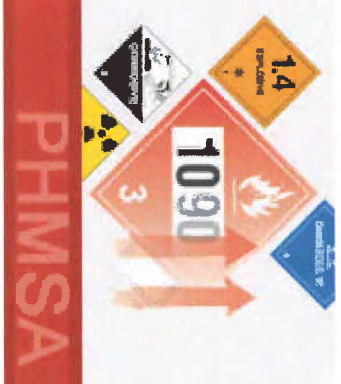

What is Regulated Medical Waste?

A hazardous material is any substance or material that can burn, explode, react violently or cause injury or harm to people, property or the environment during transport.

In 1999, DOT regulations defined medical waste as a hazardous material and medical waste is now subject to specific DOT requirements for proper packaging, labeling, transportation and training.

Hazard Class

WM000387

DOT has divided all hazardous materials into nine hazard classes and numbered them 1 through 9.

- 1 - Explosives
- 2 - Gases
- 3 - Flammable and combustible materials
- 4 - Materials that can spontaneously combust or are dangerous when wet
- 5 - Oxidizers and organic peroxide
- 6 - Poisonous materials or infectious substances
- 7 - Radioactive materials
- 8 - Corrosives
- 9 - Miscellaneous hazardous materials

Regulated Medical Waste (RMW)

WM000388

Regulated medical waste is classified under hazard class 6.2 of the DOT regulations because it poses a risk of disease transmission to humans or animals.

The DOT defines regulated medical waste as:

- A waste or reusable material, other than a culture or stock of an infectious substance, that contains an infectious substance and is generated in -
 - The diagnosis, treatment or immunization of human beings or animals;
 - Research pertaining to the diagnosis, treatment or immunization of human beings or animals; or
 - The production or testing of biological



THINK GREEN®

Cultures or Stocks

Discarded cultures and stocks of infectious substances are classified under hazard class 6.2 of the DOT regulations. They are called infectious substances by DOT regulation. Discarded cultures and stocks must meet more stringent packaging requirements beyond standard regulated medical waste.

Hazmat Employees

WM000390

All employees who dispose of regulated medical waste and infectious substances inside red biohazard bags or sharps containers are called hazmat employees by DOT. Hazmat employees are employees that:

1. Load, unload or handle hazardous materials;
2. Prepare hazardous materials for transportation; or
3. Is responsible for safety of transporting hazardous materials.



THINK GREEN.®

Hazmat Employee training

WM000391

Hazmat employees are required to receive

Hazmat training within 90 days after starting a job involving medical waste and at least every 3 years. The training must cover:

1. General awareness and familiarization with hazardous materials,
2. Function-specific training of the task the employee performs, and
3. Safety training covering emergency response, exposure protection and
4. methods for avoiding accident.



THINK GREEN.®

Function specific training

WM000392

DOT considers all hazmat employees to be shippers of regulated medical waste and/or disposed infectious substances. Shipper's responsibilities are to classify, package, mark and complete any documentation required.

Generator's Certification: " I hereby declare that the contents of this consignment are fully and accurately described above by the proper shipping name and are classified, packaged, marked and labeled/placarded, and are in all respects in proper condition for transport by highway according to applicable international and national government regulations, including applicable state regulations "



THINK GREEN:®

Function specific training

WM000393

Driver Responsibilities

- Drivers are to verify that the paperwork is accurate, and containers are packaged properly.
- Drivers are not to accept leaking or improperly packaged wastes
- Drivers are not to package waste for customers
- Drivers are not to repackage waste for customers



THINK GREEN®

Regulated Medical Waste



What goes in the RED BAG?

ALL MATERIALS SOAKED, CARED OR DRIPPING WITH BLOOD OR OTHER POTENTIALLY INFECTIOUS MATERIALS (OPIM).

SHARPS CONTAINERS that hold used sharps, sutures, scalpels, syringes and lancets - but NEVER LOOSE, always in a container.



CONTAMINATED DISPOSABLE ITEMS including IV tubing, gloves, gowns, small amounts of tissue from procedures, dressings and/or wraps.



IF NOT SOAKED WITH BLOOD OR OPIM, PLACE IN REGULAR TRASH!

NO

- REGULAR TRASH
- LOOSE SHARPS
- CHEMO WASTE
- MEDICATIONS

healthcare.wm.com

THIS MESSAGE IS FOR GENERALITY PURPOSES ONLY. ALWAYS FOLLOW APPLICABLE REGULATIONS, POLICIES AND PROCEDURES SPECIFIC TO YOUR FACILITY.



W-020114-0004



Regulated Dental Waste



What goes in the RED BAG?

ALL MATERIALS SOAKED, CARED OR DRIPPING WITH BLOOD OR OTHER POTENTIALLY INFECTIOUS MATERIALS (OPIM).

SHARPS CONTAINERS that hold used sharps, sutures, scalpels, syringes and lancets - but NEVER LOOSE, always in a container.



CONTAMINATED DISPOSABLE ITEMS including IV tubing, gloves, gowns, small amounts of tissue from procedures, dressings and/or wraps.



IF NOT SOAKED WITH BLOOD OR OPIM, PLACE IN REGULAR TRASH!

NO

- REGULAR TRASH
- LOOSE SHARPS
- USED X-RAY CHEMICALS
- HEAVY METALS
 - LEAD ACETATE
 - LEAD OR RENTAL
 - LEAD FOIL FOR X-RAY FILMS
 - THERM AFTER ANALOGICAM WITH ANALOGICAM

healthcare.wm.com

THIS MESSAGE IS FOR GENERALITY PURPOSES ONLY. ALWAYS FOLLOW APPLICABLE REGULATIONS, POLICIES AND PROCEDURES SPECIFIC TO YOUR FACILITY.

THINK GREEN.®

W-020114-0005



Packaging



THINK GREEN.®

Packaging

WM000396

The chosen package must meet special DOT specific criteria and must go through special testing to become DOT certified.

Regulated Medical Waste should be packaged in PG II containers (PG II defines the packaging group designated for such wastes danger)

The Generator is responsible for using the proper biohazard bags, and sharps containers, as well as closing red biohazard bags and sharps containers correctly. The Generator is also responsible for placing closed biohazard bags and sharps in the tubs and/or containers provided by WM Healthcare Solutions.

Packaging

WM000397

Safe Handling: Proper Waste Packaging

Containers in general must be:

- maximum net capacity of 119 gallons
- maximum net mass of 882 pounds
- packaged as non-bulk
- Any containers not meeting the above restrictions must have a exemption by DOT



THINK GREEN.®

Packaging

- a. For other than a waste culture or stock of an infectious substance, the specific packaging containing RMW should be designed, constructed, maintained, filled, its contents limited, and closed in a rigid, non-bulk package.
- b. Red plastic biohazard bags with a minimum thickness of 1.25 mil are required to be used. (we provide a 1.5 mil bag)
- c. All red biohazard bags are required to be closed by twisting and tying a square knot or by twisting and folding the twist over itself and taping the bag closed.

Categories of Medical Wastes

- Regulated Medical Waste (RMW)
- Pathological (Path)
- Chemotherapy (Chemo)
- Sharps & Sharps by-mail
- Pharmaceutical waste
- Culture & Stocks (Petri dish)
- Infectious waste
- Liquid medical waste
- Radioactive Medical Waste



Segregation

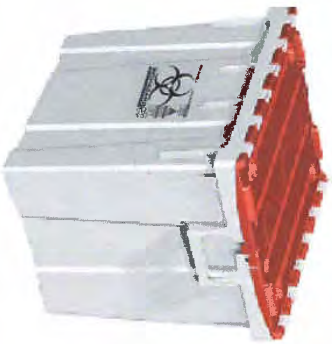

Pathological

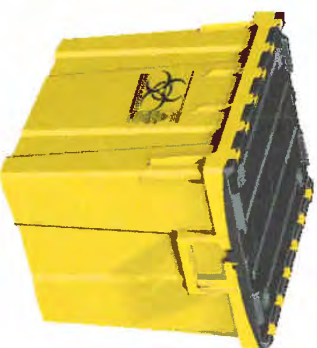

Chemo



Standard
Red-bag

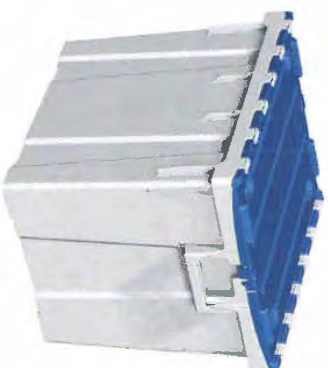

Pharmaceutical

Segregation

| Container Type | Handling Requirement | Secondary Packaging |
|---------------------------------------|---|---|
| Sharps container without gasket | Sharps containers must be over packed with secondary packaging to ensure they are leak proof. | Place sharps container in bag and place in reusable container. Place sharps container in bag and place in corrugated box. |
| Sharps container with gasket and vent | Sharps container must be properly closed per the manufacturer requirements and vent properly closed | No additional packaging required as long as the vent is properly closed and lid is properly sealed |



THINK GREEN.®

Container Markings

| | |
|---|---|
|  | |
| WMM WASTE MANAGEMENT healthcare.wm.com (888) 769-4246 | |
| ¡ CAUTION CONTAINS MEDICAL WASTE WHICH MAY BE BIOHAZARDOUS | THIS PACKAGE MAY CONTAIN SHARPS |
| BIOHAZARD UN3291, Regulated Medical Waste, n.o.s., 6.2, PG II | ¡ PRECAUCIÓN CONTIENE DESECHOS MÉDICOS QUE PUEDEN SER BIOPELIGROSO |
| THIS CONTAINER IS REUSABLE! DO NOT DISCARD | |



THINK GREEN.

Container Markings

WM000403

The containers that are used must have the following markings:

- a. the universal biohazard symbol,
- b. the word, “Biohazard”,
- c. the proper shipping name, “Regulated Medical Waste”,
- d. the proper class of material 6.2
- e. the packaging group “pg II”
- f. the UN number, “UN3291”



Some state regulations are more strict in their interpretations.

Container Markings

There are four UN numbers that can be used to classify goods that contain infectious substances or pathogens, as dangerous goods for transport:

- UN 2814, Infectious Substances (affecting humans)
- UN 2900, Infectious Substances (affecting animals)
- UN 3291, Clinical Waste (Bio Medical Waste or Regulated Medical Waste)**
- UN 3373, Diagnostic Specimens

Container Labels

REGULATED MEDICAL WASTE

1605-0025882-00A02

Generator: Med A Gene
6655 Hillcroft Suite 100
Houston, TX 77081

EPA#

Transporter: Waste Management Healthcare Solutions
7505 State Hwy 65
Anahuac, TX 77514

MSW# 50114

281-487-5000

DATE _____ WEIGHT _____

RED BAG

PULL

1605-0025882-00A02

Generator: MED A GENE
6655 HILLCROFT 100
HOUSTON TX 77081

Transporter: WASTE MANAGEMENT
7505 STATE HWY 65
ANAHUAC TX 77514

281-487-5000

MSW # 50114

Weight: _____ Date: _____

RED BAG WASTE

PULL



THINK GREEN®

Container Labels

WM000406

Under DOT regulations the Generator is required to mark the container with the following information:

- a. The name, and address of the generator.
- b. The name, address, and phone number of the transporter.
- c. The permit number or US EPA id number.



THINK GREEN.®

Container Labels

The labels can be provided by the contracted medical waste collection company, but in order to properly adhere to the packaging guidelines and “Generators Certification”, it is the responsibility of the Generator to affix the label to the container.



THINK GREEN.®

Container Labels

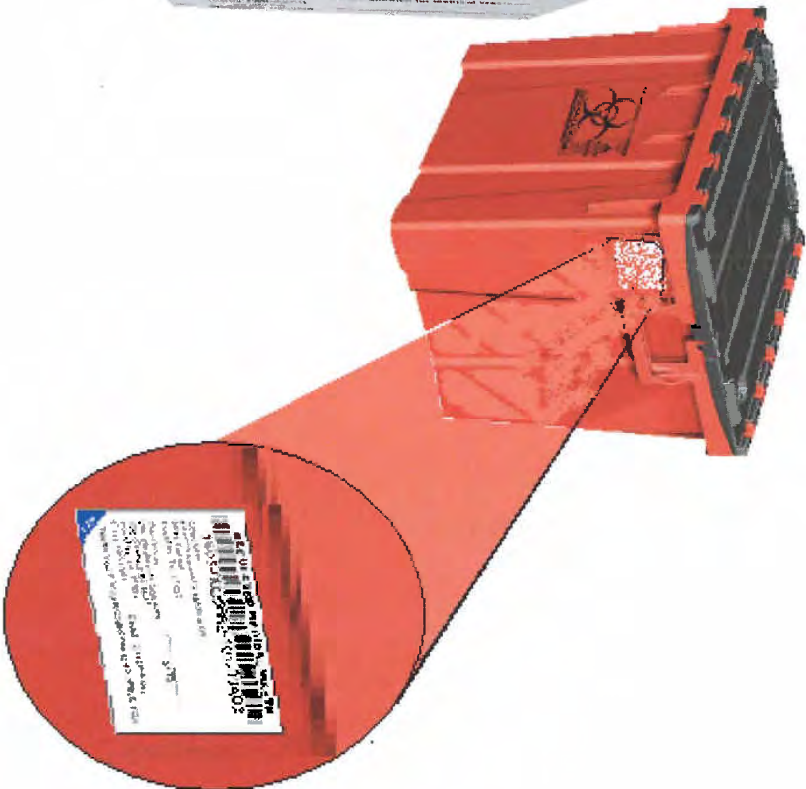
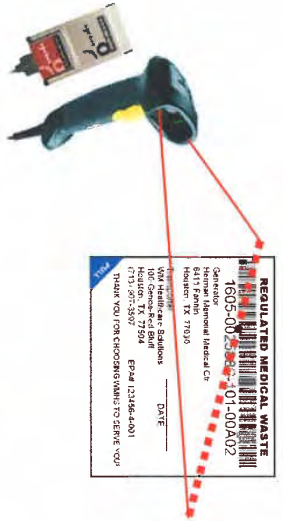

THINK GREEN.®

Container Labels

REGULATED MEDICAL WASTE

1605-0025882-00A02

Generator:
Med A Gene
6655 Hillcroft Suite 100
Houston, TX 77081

EPA#

MSW# 50114

Transporter:
Waste Management Healthcare Solutions
7505 State Hwy 65
Anahuac, TX 77514 281-487-5000

DATE _____ WEIGHT _____

RED BAG

PULL

1605-0025882-00A02

Generator:
MED A GENE
6655 HILLCROFT 100
HOUSTON TX 77081

Transporter:
WASTE MANAGEMENT
7505 STATE HWY 65
ANAHUAC TX 77514

MSW# 50114

Weight _____ Date _____

RED BAG WASTE

PULL



THINK GREEN.

Transportation Documentation

Each time the medical waste is collected from the generator they are required to complete a tracking document. The tracking document is a record of the type and quantity of the waste offered for transportation and serves as the documentation or shipping papers for transport of medical waste. The tracking documents must be signed by an authorized person designated and trained to package and present containers for collection.

Transportation Documentation

Each tracking document is required to contain:

- a. an emergency response phone number
- b. the Generator's name, address, and telephone
- c. the Transporters name, address, telephone number along with applicable permit number
- d. the designated facility for disposal along with associated permit number
- e. Signatures and date of collection from the generator and transporter. The document will also require the treatment facility to sign and date as product has been treated in accordance with regulations.

Documentation summary

- RMW cannot be transported without complete tracking documents
- they must be readily available, recognizable, distinguishable
- must be within reach of driver while seated with seat belt buckled
- must be stored in holder mounted on driver door and on seat when driver is not in vehicle
- must be legible
- must be in English
- must have emergency response information and phone number

Documentation summary

- Tracking documents: what it must include
- Proper shipping name:
 - **Regulated Medical Waste**
- Hazard Class or Division:
 - **6.2**
- Identification Number:
 - **UN 3291**
- Packing Group:
 - **PG II**



Documentation summary

- Tracking documents: what it must include
- Total by net or gross mass or capacity must be listed
- DOT exemption # if applicable
- Shippers Certification: must be legibly signed manually, by typewriter or other mechanical means by the shipper
- all signed documents must be kept for 3 years

Tracking Document



WASTE MANAGEMENT
INTEGRATED WASTE, WMI.COM

ROUTE NO. - W501

TRUCK NUMBER

MEDICAL WASTE TRACKING FORM
SERVICE DATE: 1/10/2008



DOCUMENT #: 0300000104

| GENERATOR | | | |
|--|----------------------|--|--|
| Sed | Generator No. | 0000200001 | 24-Hour Emergency Response (800) 424-9300 |
| 1 | Generator Name | METROPOLITAN CLINIC 6650 Roswell Rd Ne Sandy Springs, GA 30328-3141 (407) 923-4331 JULIO PENALVER | State Generator's ID No. Generator's US EPA ID No. |
| 2a | Description of Waste | Regulated Medical Waste, RCRA 31 UN 328, PCH | 2b. Container Type 31 GALLON (Regulated Medical Waste) (Bio) 31 gal |
| | | | 2c. No. of Containers |
| | | | 2d. lb. or volume |
| <input type="checkbox"/> 7A. Designated Facility: WMAATF Metropolitan Treatment 315 Bell Park Drive Woodstock, GA 30186 (770) 517-4202 Permit #: EPD 028-042P | | | |
| <input type="checkbox"/> 7B. Transfer Facility: WMAATF 315 Bell Park Drive Woodstock, GA 30186 (770) 517-4202 Permit #: EPD 028-042P | | | |
| <input type="checkbox"/> 7C. Alternate Facility: WMAATF 7905 State Hwy 55 Arabian, TX 77514 (409) 267-3913 Permit #: MSW 2239-A | | | |
| <input type="checkbox"/> 7E. Alternate Facility: | | | |
| 4. Transporter 1 is to check box if this is a through shipment <input type="checkbox"/> TOTALS (↓) | | | |
| Transporter 1 Address: WY AIT? 315 Bell Park Dr Woodstock, GA 30186 Transporter 1 Acknowledgment of Receipt of Materials Signature: _____ Date: _____ Phone #: 770-517-4203 Applicable permit number: PER-028-130001 | | Transporter 2 / Intermediate Handler Signature: _____ Date: _____ Phone #: _____ Acknowledgment of Receipt of Materials Signature: _____ Date: _____ Permit number: _____ | |
| 6. Discrepancy / Comments: _____ | | | |
| 7. Treatment Facility Printed Certification of Receipt and Treatment The entry date for receipt of materials shall be the date of receipt of materials at the treatment facility. The entry date for receipt of materials shall be the date of receipt of materials at the treatment facility. The entry date for receipt of materials shall be the date of receipt of materials at the treatment facility. | | | |

3. Generator's Certification: I hereby declare that the contents of this consignment are fully and accurately described above by the proper shipping name and are classified, packaged, marked and labeled in accordance with applicable international and national government regulations, including applicable state regulations.

Signature: _____ Print / Typed Name: _____ Date: _____

White copy - Transporter/Collection Yellow copy - Treatment Facility Orange copy - Transfer Facility Pink copy - Generator/Customer



THINK GREEN.

Marking (placard)



THINK GREEN.®

Vehicle Marking (placard)

- RMW is not required to be placarded unless:
 - it is transporting at least one full exempted container; or when transporting non-bulk containers from a single facility weighing 8,820 lbs or more
 - If markings are required:
 - driver is responsible for insuring the markings are displayed

Vehicle Marking (placard)

- the marking displayed is 3291; displayed using white, square-on-point configuration, on the two sides of the vehicle and on the back of the vehicle



Driver Requirements

Class A

Class B



Class C –
Non-air brake



THINK GREEN:®

Driver Requirements

- All employees are trained properly in:
 - Vehicle Inspections (pre and post trip)
 - Spill clean up
 - Proper waste handling
 - DOT RMW specific training
 - Random Drug and Alcohol testing
 - Refresher training annually
- All vehicles are equipped with:
 - Spill Kits
 - DOT number and appropriate State specific information.



Myths

- Drivers need to have a hazardous materials license endorsement to transport Regulated Medical Waste...
- Drivers need to have a Commercial Drivers License to transport Regulated Medical Waste...
- Regulated Medical Waste and Hazardous Waste can be transported on the same vehicle...
- Dental waste can be handled the same as Regulated Medical Waste

Other Regulatory Bodies

WM000422



Joint Commission
on Accreditation of Healthcare Organizations



- Occupational Safety & Health Administration (OSHA)
 - Bloodborne Pathogen (BBP) Standards
- Department of Transportation (DOT)
- U.S. Environmental Protection Agency (EPA)
- U.S. Centers for Disease Control and Prevention (CDC)
- Joint Commission on the Accreditation of Healthcare Organizations (JCAHO)
- Drug Enforcement Agency (DEA)
- Federal Drug Administration (FDA)
- State and Local Regulatory Agencies



THINK GREEN.®

On a tracking document, the Generator's authorized hazmat representative must:

- A. Print and sign and date under the treatment site.
- B. Print and sign under the shipper's certification.
- C. Sign and date under the shipper's certification.
- D. Sign and date on the transporter's section.

Question # 1

On a tracking document, the Generator's authorized hazmat representative must:

Question # 1

- C. Sign and date under the shipper's certification.

The generator is responsible for certifying that the tracking document is correct?

- A. True
- B. False

Question # 2

The generator is responsible for certifying that the tracking document is correct?

A. True

Question # 2

The Emergency Response phone number must be monitored:

- A. During the week and on a voicemail during the weekend.
- B. 24 hours per day by anyone who can contact someone with knowledge.
- C. Not at all.
- D. 24 hours per day by a person who is knowledgeable of the hazardous material and has emergency response information.

Question # 3

The Emergency Response phone number must be monitored:

Question # 3

- D. 24 hours per day by a person who is knowledgeable of the hazardous material and has emergency response information.

On the outer packaging of RMW, the labeling must contain the Universal Biohazard Symbol, the word Biohazard, UN 3291 and the words Regulated Medical Waste?

- A. True
- B. False

Question # 4

On the outer packaging of RMW, the labeling must contain the Universal Biohazard Symbol, the word Biohazard, UN 3291 and the words Regulated Medical Waste?

A. True

Question # 4

All emergency information regarding a hazardous material must:

- A. Be available at a location away from the hazmat package.
- B. Be accessible to all employees.
- C. Be printed in English
- D. All of the above.

Question # 5

All emergency information regarding a hazardous material must:

D. All of the above.

Question # 5

In the hazardous Material Table, PG is an indication of :

- A. The size of the hazmat package.
- B. The weight of the hazmat package.
- C. The degree of danger the material presents.
- D. The size and the weight of the hazmat package.

Question # 6

In the hazardous Material Table, PG is an indication of :

- C. The degree of danger the material presents.

Question # 6

No person may offer or accept a hazardous material for transportation unless the hazardous material is properly:

- A. Classed, described, packaged, marked, labeled and in condition for shipment
- B. Classed, marked and labeled
- C. Packaged, labeled, in condition for shipment and described
- D. None of the above

Question # 7

No person may offer or accept a hazardous material for transportation unless the hazardous material is properly:

- A. **Classed, described, packaged, marked, labeled and in condition for shipment**

Question # 7

No person shall represent that a hazardous material is present in a vehicle if the hazardous material is not present.

- A. True
- B. False

Question # 8

No person shall represent that a hazardous material is present in a vehicle if the hazardous material is not present.

A. True

Question # 8

When should the 3291 marking be displayed on the truck?

- A. When transporting empty exempted containers.
- B. When transporting any hazardous waste.
- C. When transporting full exempted containers or 8,820 pounds or more from a single facility.
- D. Check the N.A.E.R.G. for guidance.

Question # 9

When should the 3291 marking be displayed on the truck?

- C. When transporting full exempted containers or 8,820 pounds or more from a single facility.
- # Question # 9

Spill clean up is done when:

- A. Waste piles up to an unsightly level
- B. There is any blood spilled
- C. Waste falls from within the truck box
- D. None of the above
- E. B and C

Bonus Question

Spill clean up is done when:

E. B and C

Bonus Question

How can this help me??

Knowing what responsibility the Generator has is important...

Understanding that there are State Specific regulations may assist you in discussing RMW...

Having knowledge of where you can research this topic or having persons to ask builds confidence...

Having literature that you can distribute is a tool that should not be overlooked.



THINK GREEN.®

How can this help me??

Consolidation points for hospitals and regulations
for regional transportation between Main
Hospital and satellites...

Knowing what sharps containers are considered
DOT compliant and what may require
secondary packaging...

Knowing what size containers are approved for
the hospital...

If you do not know, ASK...



THINK GREEN.®

Sites for reference

DOT - FMCSA §173.197 Regulated Medical Waste

<http://www.fmcsa.dot.gov/rules-regulations/administration/fmcsr/fmcsruletext.aspx?chunkKey=090163348004758f&keyword=173>

OSHA - BBP 1910.1030

<http://www.osha.gov/pls/oshaweb/owaquery.qyery docs?src doc type=INTERPRETATIONS&src anchor name=1910.1030&src ex doc type=INTERPRETATIONS&src unique file=119921215>

Sites for reference

EPA Hazardous Waste Regulations - 40 CFR 262 & 263 (code of federal regulations)

<http://ecfr.gpoaccess.gov/cgi/t/text/text-idx?c=ecfr;sid=7ab43a4e2f340fae3200b2560f73d2aa;rgn=div5;view=text;node=40%3A25.0.1.1.3;idno=40;cc=ecfr>

Health and Safety Executive - UN 3291

<http://www.hse.gov.uk/cdg/pdf/infect-subs.pdf>

Questions??

Tammy Jean Brasher
Product Line Manager
Healthcare Solutions
(713) 512-6238

tbrasher@wm.com



THINK GREEN:®

Exhibit 3



Medical Waste Acceptance Protocol

8111 1st Ave South
Seattle, WA 98108

Medical Waste Acceptance Protocol (MWAP)

WM HEALTHCARE SOLUTIONS accepts those wastes that are generated in the diagnosis, treatment, or immunization of humans or animals or related research, in the production/testing of biologicals (vaccines), and in the preparation and administration of chemotherapy agents. Acceptance practices are subject to those wastes defined by federal, state, and local laws as medical (Biohazardous, biomedical, and infectious) waste.

1) Acceptable Wastes at WM HEALTHCARE SOLUTIONS

- a) Medical and related byproducts associated with health care, research and development companies.
- b) Biohazardous Waste, Including Pathological Waste:
- c) Laboratory waste including:
 - i. Human or animal cultures
 - ii. Culture/stocks of infectious agents
 - iii. Bacteria, viruses, spores, vaccines and related waste generated in the production thereof Microbiologic specimens and related waste
- d) Surgical tissues/tissues, contaminated animal parts, tissues, carcasses, or body fluids (pathological waste exclusive of preservative agents)
- e) Fluid blood/blood products, containers/equipment and articles contaminated with blood/blood products.
- f) Medical waste contaminated with excretions, exudates, secretions, body fluids including, but not limited to, isolation waste.
- g) Sharps Waste – including but not limited to:
 - Needles, syringes, blades, needles with attached tubing disposable surgical instruments.
 - Medical/laboratory glassware including slides, pipettes, blood tubes, blood vials, contaminated broken glass.

- h) Upon approval of WM HEALTHCARE SOLUTIONS, other medical waste as required by the infection control staff, a physician, a veterinarian, or local health officer to be isolated and handled as regulated medical waste.

2) Pharmaceutical Waste (not hazardous)

- a) Pharmaceutical waste means a prescription or over the counter human or veterinary drug, including but not limited to a drug as defined in Section 109925 or the Federal Food, Drug and Cosmetic Act as amended, (21 U.S.C.A. Sec. 321(g)(1)).

3) Trace Chemotherapy Waste (Antineoplastic / Cytotoxic Drugs):

- a) Such as IV tubing and bags/bottles which are being discarded and are considered incidental to preparation and administration of the drugs. Intravenous tubing, bags, bottles vials and syringes used in chemotherapy preparation and administration must be “empty” containing only residual amounts of antineoplastic drugs. It is recommended that each client contact WM HEALTHCARE SOLUTIONS, for guidance on the proper management of these items defined as “Empty” or “Trace”. State or local regulatory agencies also provide direction for hazardous waste compliance regulations.

4) Medical waste contaminated with low-level Radioactive Waste

- a) Under no circumstances will WM HEALTHCARE SOLUTIONS accept any medical waste contaminated with low-level radioactive waste. The facility will maintain monitoring equipment to ensure compliance. Any container reflecting a level above three times background will be rejected. It is recommended that each client contact WM HEALTHCARE SOLUTIONS for guidance on the proper management of these items.

5) Segregation and Packaging of Waste:

- a) Biohazardous Waste:
 - i) Waste material must be segregated at the point of origin and placed in at least one red biohazard bag, which meets the requirements of MWMA CHSC section 117630. Bags must be tied or otherwise secured to prevent leakage or expulsion of contents. Prior to use, bags must be labeled with, generators name, address and phone number.
 - ii) Sharp Waste – Needles, blades, syringes, broken medical glassware

(1) These wastes must be segregated at the point of use and placed in rigid, puncture-resistant containers which when sealed are leak resistant and cannot be easily opened. Prior to use, sharps containers must be labeled with, generators name, address and phone number.

b) Body fluids, suctioned fluids and other non-chemical fluids

- i) Any volume of fluids which are not absorbed within other waste materials such as sponges or dressings must be within leak-resistant, break resistant containers that are tightly lidded to prevent leakage.
- ii) The discharge of liquid and semi-liquid wastes other than hazardous waste, laboratory waste, and microbiological specimens to a public sewage system is acceptable under the California Medical Waste Management Act, if performed in a manner which does not pose an occupational hazard per Cal/OSHA Standards and is approved by the local sewer entity, when applicable.

6) Containment, Labeling, and Marking:

a) Biohazardous and Sharps Waste

Medical waste must be placed by the client in to properly lidded and secured containers meeting the requirements of Section 118280 of the MWMA. Only containers provided by WM HEALTHCARE SOLUTIONS are approved for transportation. Transport containers for these wastes are red or gray in color. Biohazardous waste/sharps wastes are acceptable for steam autoclave processing, incineration, or CDPH approved alternative treatment.

b) Other Medical Wastes

- i) **“Trace” chemotherapy waste** must be segregated and packaged into appropriate containers, separated from other Biohazardous waste and sharps waste. Refer to WM HEALTHCARE SOLUTIONS packaging guide for specific requirements. Transport containers for these wastes are yellow in color labeled, Chemotherapy waste or Chemo, “For incineration only”.
- ii) **Pathological waste** must be segregated and packaged into appropriate containers, separated from other Biohazardous waste and sharps waste. Refer to WM HEALTHCARE SOLUTIONS packaging guide for specific requirements. Transport containers for these wastes are white or red (with special labeling) in color labeled, Pathology waste or Path, “For incineration only”.

- iii) **Pharmaceutical waste** must be segregated and packaged into appropriate containers, separated from other Biohazardous waste and sharps waste. Refer to WM HEALTHCARE SOLUTIONS packaging guide for specific requirements. Transport containers for these wastes are typically blue in color and/or labeled "Pharm for incineration only".
- iv) **Animal waste** must be segregated and packaged into appropriate containers, separated from other Biohazardous waste and sharps waste. Refer to WM HEALTHCARE SOLUTIONS packaging guide for specific requirements. Transport containers for these wastes are white or red (with special labeling) in color labeled, Pathology waste or Path, "For incineration only".

In order to insure that safe handling and proper treatment and appropriate clean up techniques are followed in the event of a spill, WM HEALTHCARE SOLUTIONS requires that all Other Medical Waste for incineration be segregated from medical waste for autoclaving and labeled as such.

c) **Optional Secondary Containers**

- i) **Optional containers** such as disposable cartons, fiber drums, sharps containers or reusable plastic tubs must be approved by WM HEALTHCARE SOLUTIONS prior to packaging these materials. It is the clients' responsibility to assure that all containers and containment systems meet state and local regulations along with this MWAP.

Exhibit 4

STRAIGHT BILL OF LADING



| | | | |
|--|--|---|-----------|
| Date: | | Shipper No. WMHS2012SEA- | |
| Shipped From: WM Healthcare Solutions 8101 1 st Ave South Seattle, WA 98108 855-427-1999 | | Shipped To: Klamath Garbage 1812 Greensprings Drive Klamath Falls, OR 97601 Ben Hirengen 541-882-7751 or 541-205-1028 | |
| Route | | Vehicle No. | Customer# |
| Qty. | | Kind of Packaging, Description of Articles, Special Marks and Exceptions | |
| | | | |
| | | | |
| | | | |
| | | | |
| | | | |
| | | | |
| | | | |
| Bill Freight Charge to: WM Healthcare Solutions | | COD Amount | |
| Mailing Address: 8111 1 st Ave South | | COD Fee: Prepaid Collect | |
| City, State, Zip: Seattle, WA 98108 | | Is Customer Check Acceptable for COD? | |
| | | Yes No Check No. | |
| | | Freight Charges: Prepaid Collect | |

This is to certify that the above named materials are properly classified, described, packaged, marked and labeled, and are in proper condition for transportation according to the applicable regulations of the Department of Transportation.

Received subject to classifications and lawfully filed tariffs in effect on the date of issue of this Straight Bill of Lading, the property described above, in apparent good order, except as noted (contents and condition of the contents of packages unknown), marked, consigned and destined as shown above which said company (the word company being understood throughout this contract as meaning any person or corporation in possession of the property under the contract) agrees to carry to its usual place of delivery at said destination, if on its own railroad, water line, highway route or routes, or within the territory of its highway operations, otherwise to deliver to another carrier on the route to said destination. It is mutually agreed as to each carrier of all or any of said property, over all or any portion of said route to destination and as to each party at any time interested in all or any of said property, that every service to be performed hereunder shall be subject to all the Straight Bill of Lading terms and conditions in the governing classification of the date of shipment.

Shipper hereby certifies that he is familiar with all the Bill of Lading terms and conditions in the governing classification and the said terms and conditions are hereby agreed to by the shipper and accepted for himself and his assigns.

| | | |
|---|--------------|------------------------------|
| Shipper: WM Healthcare Solutions Phone:855-427-1999 | | Received by: |
| Authorized Signature: | Date: | Authorized Signature: |
| Print Name: | | Date: |

STRAIGHT BILL OF LADING & Medical Waste Tracking Document



| | | | |
|--------------|--|-------------------------------------|-------------|
| Date: | | Shipment: WMHS2011SEA | Page 1 of 2 |
|--------------|--|-------------------------------------|-------------|

| | |
|--|--|
| Ship from: Waste Management Healthcare Solutions 8101 1 st Ave South Seattle, WA 98108 Permit # PR0080378 Tel No.: 206-406-3030 | Ship to: Waste Management Healthcare Solutions 4280 Bandini Boulevard Vernon, CA 90058 Permit #TS/OST 81 Tel No.: 323-307-0514 |
|--|--|

| | | |
|--------------|--------------------|---|
| Route | | Received by: WM Healthcare Solutions, Inc. |
| | Date range: | Signature: _____ Date: _____ |

| Qty. | Cont. Size | Kind of Packaging, Description of Articles, Special Marks and Exceptions | Weight (lb.) |
|------|------------|---|--------------|
| | | Biohazardous Waste – Sharps Regulated Medical Waste, N.O.S., 6.2, UN3291, PG II Tubs and Sharps Containers DOCUMENT # | |
| | | Biohazardous Waste – Sharps Regulated Medical Waste, N.O.S., 6.2, UN3291, PG II Tubs and Sharps Containers DOCUMENT # | |
| | | Biohazardous Waste – Sharps Regulated Medical Waste, N.O.S., 6.2, UN3291, PG II Tubs and Sharps Containers DOCUMENT # | |
| | | Biohazardous Waste – Sharps Regulated Medical Waste, N.O.S., 6.2, UN3291, PG II Tubs and Sharps Containers DOCUMENT # | |
| | | Biohazardous Waste – Sharps Regulated Medical Waste, N.O.S., 6.2, UN3291, PG II Tubs and Sharps Containers DOCUMENT # | |
| | | Biohazardous Waste – Sharps Regulated Medical Waste, N.O.S., 6.2, UN3291, PG II Tubs and Sharps Containers DOCUMENT # | |
| | | Biohazardous Waste – Sharps Regulated Medical Waste, N.O.S., 6.2, UN3291, PG II Tubs and Sharps Containers DOCUMENT # | |
| | | Biohazardous Waste – Sharps Regulated Medical Waste, N.O.S., 6.2, UN3291, PG II Tubs and Sharps Containers DOCUMENT # | |
| | | Biohazardous Waste – Sharps Regulated Medical Waste, N.O.S., 6.2, UN3291, PG II Tubs and Sharps Containers DOCUMENT # | |
| | | Biohazardous Waste – Sharps Regulated Medical Waste, N.O.S., 6.2, UN3291, PG II Tubs and Sharps Containers DOCUMENT # | |
| | | Biohazardous Waste – Sharps Regulated Medical Waste, N.O.S., 6.2, UN3291, PG II Tubs and Sharps Containers DOCUMENT # | |
| | | Biohazardous Waste – Sharps Regulated Medical Waste, N.O.S., 6.2, UN3291, PG II Tubs and Sharps Containers DOCUMENT # | |
| | | Biohazardous Waste – Sharps Regulated Medical Waste, N.O.S., 6.2, UN3291, PG II Tubs and Sharps Containers DOCUMENT # | |
| | | Biohazardous Waste – Sharps Regulated Medical Waste, N.O.S., 6.2, UN3291, PG II Tubs and Sharps Containers DOCUMENT # | |
| | | Biohazardous Waste – Sharps Regulated Medical Waste, N.O.S., 6.2, UN3291, PG II Tubs and Sharps Containers DOCUMENT # | |
| | | Biohazardous Waste – Sharps Regulated Medical Waste, N.O.S., 6.2, UN3291, PG II Tubs and Sharps Containers DOCUMENT # | |
| | | Biohazardous Waste – Sharps Regulated Medical Waste, N.O.S., 6.2, UN3291, PG II Tubs and Sharps Containers DOCUMENT # | |

| | | | |
|--|--------------------------------|----------------|---|
| Loose Pieces | Pallets said to contain | Cartons | COD Amount |
| Bill Freight Charge to: Waste Management Healthcare Solutions | | | COD Fee: Prepaid Collect |
| Mailing Address: 8111 1st Ave South | | | Is Customer Check Acceptable for COD? |
| City, State, Zip: Seattle, WA 98108 | | | Yes No Check No. |
| | | | Freight Charges: Prepaid Collect |

This is to certify that the above named materials are properly classified, described, packaged, marked and labeled, and is in proper condition for transportation according to the applicable regulations of the Department of Transportation.

Received subject to classifications and lawfully filed tariffs in effect on the date of issue of this Straight Bill of Lading, the property described above, in apparent good order, except as noted (contents and condition of the contents of packages unknown), marked, consigned and destined as shown above which said company (the word company being understood throughout this contract as meaning any person or corporation in possession of the property under the contract) agrees to carry to its usual place of delivery at said destination, if on its own railroad, water line, highway route or routes, or within the territory of its highway operations, otherwise to deliver to another carrier on the route to said destination. It is mutually agreed as to each carrier of all or any of said property, over all or any portion of said route to destination and as to each party at any time interested in all or any of said property, that every service to be performed hereunder shall be subject to all the Straight Bill of Lading terms and conditions in the governing classification of the date of shipment.

Shipper hereby certifies that he is familiar with all the Bill of Lading terms and conditions in the governing classification and the said terms and conditions are hereby agreed to by the shipper and accepted for himself and his assigns.

| | |
|---|---|
| Shipper: WM Healthcare Solutions 8101 1 st Ave South Seattle, WA 98108 Permit # PR0080378 | Carrier: WM Healthcare Solutions, Inc. 4280 Bandini Boulevard Vernon, CA 90058 Permit #TS/OST 81 |
| Authorized Signature: Date: | Authorized Signature: Date: |
| Print Name: | Print Name: |



MEDICAL WASTE TRACKING DOCUMENT
SERVICE DATE:

ROUTE No. -

TRUCK NUMBER

DOCUMENT #:

| | | |
|---------------------------|---------------|---|
| Seq | Generator No. | 24-Hour Emergency Response (800) 424-9300 |
| 1. | | |
| State Generator's ID No. | | |
| Generator's US EPA ID No. | | |

| 2a. Description of Waste | 2b. Container Type | 2c. No of Containers | 2d. lb. or Volume |
|---|--------------------|----------------------|-------------------|
| TOTALS | | | |
| Applicable permit number/s: G237 Phone #: (855) 427-1999 | | | |

4. Transporter 1 is to check box if this is a through shipment

Transporter 1 Address: Waste Management of Washington
8101 First Avenue South
Seattle, WA 98108

Transporter 1 Acknowledgement of Receipt of Materials

Signature _____ Print / Typed Name _____ Date/Time _____

5. Transporter 2 / Intermediate Handler

Address: _____ Phone #: _____

Signature _____ Permit number: _____
Print / Typed Name _____ Date _____

Intermediate Handler 2 / Acknowledgement of Receipt of Materials

6. Discrepancy _____

Comments _____

TD terminated New TD # _____

Signature _____ Date _____

3. Generator's Certification: "I hereby declare that the contents of this consignment are fully and accurately described above by the proper shipping name and are classified, packaged, marked and labeled/placarded, and are in full respects in proper condition for transport by highway according to applicable international and national government regulations, including applicable state regulations."

Signature _____ Date _____

- 7A. Autoclave Facility:
WM Healthcare Solutions
4280 Bandini Blvd
Vernon, CA 90058
Phone (323) 307-0557
Permit #: TS/OST 81
- 7B. Transfer Facility:
Waste Management
8101 1st Avenue South
Seattle, WA 98108
Phone (855) 427-1999
- 7C. Incineration Facility:
Covanta Marlon
4850 Brooklake Road NE
Brooks, OR 97305
Phone (505) 393-0890
Permit #: DEQ #364
- 7D. Autoclave Facility:
Waste Management
Seattle Biomedical Waste
Treatment Facility
149 SW Kenyon Street
Seattle, WA 98108
Phone (206) 505-9663
Permit #: PR0000378
- 7E. Alternate Facility:
Waste Management
1390 E Commercial Row
Reno, NV 89512
Phone (775) 326-2409
Permit #: MSWL-003
IWH-004

REGULATED MEDICAL WASTE

Generator / Permit #:

Transporter / Permit #:

DATE

WEIGHT

BIOHAZARDOUS

REGULATED MEDICAL WASTE

Generator / Permit #:

Transporter / Permit #:

DATE

WEIGHT

BIOHAZARDOUS

REGULATED MEDICAL WASTE

Generator / Permit #:

Transporter / Permit #:

DATE

WEIGHT

BIOHAZARDOUS

REGULATED MEDICAL WASTE

Generator / Permit #:

Transporter / Permit #:

DATE

WEIGHT

BIOHAZARDOUS

REGULATED MEDICAL WASTE

Generator / Permit #:

Transporter / Permit #:

DATE

WEIGHT

BIOHAZARDOUS

REGULATED MEDICAL WASTE

Generator / Permit #:

Transporter / Permit #:

DATE

WEIGHT

BIOHAZARDOUS

REGULATED MEDICAL WASTE

Generator / Permit #:



Transporter / Permit #:

WASTE MANAGEMENT

DATE

WEIGHT

INCINERATION

REGULATED MEDICAL WASTE

Generator / Permit #:



Transporter / Permit #:

WASTE MANAGEMENT

DATE

WEIGHT

INCINERATION

REGULATED MEDICAL WASTE

Generator / Permit #:



Transporter / Permit #:

WASTE MANAGEMENT

DATE

WEIGHT

INCINERATION

REGULATED MEDICAL WASTE

Generator / Permit #:



Transporter / Permit #:

WASTE MANAGEMENT

DATE

WEIGHT

INCINERATION

REGULATED MEDICAL WASTE

Generator / Permit #:



Transporter / Permit #:

WASTE MANAGEMENT

DATE

WEIGHT

INCINERATION

REGULATED MEDICAL WASTE

Generator / Permit #:



Transporter / Permit #:

WASTE MANAGEMENT

DATE

WEIGHT

INCINERATION

PULL

PULL

PULL

PULL

PULL

PULL

REGULATED MEDICAL WASTE

Generator / Permit #:



Transporter / Permit #:

DATE

WEIGHT

PULL

SHARPS

REGULATED MEDICAL WASTE

Generator / Permit #:



Transporter / Permit #:

DATE

WEIGHT

PULL

SHARPS

REGULATED MEDICAL WASTE

Generator / Permit #:



Transporter / Permit #:

DATE

WEIGHT

PULL

SHARPS

REGULATED MEDICAL WASTE

Generator / Permit #:



Transporter / Permit #:

DATE

WEIGHT

PULL

SHARPS

REGULATED MEDICAL WASTE

Generator / Permit #:



Transporter / Permit #:

DATE

WEIGHT

PULL

SHARPS

REGULATED MEDICAL WASTE

Generator / Permit #:



Transporter / Permit #:

DATE

WEIGHT

PULL

SHARPS

Exhibit 5

CLEANING UP SPILLS OF BLOODBORNE PATHOGENS

Potentially infectious material (PIM) includes:

1. The following human body fluids: blood, semen, vaginal secretions, cerebrospinal fluid, synovial fluid, pleural fluid, pericardial fluid, peritoneal fluid, amniotic fluid, saliva in dental procedures, any body fluid that is visibly contaminated with blood, and all body fluids in situations where it is difficult or impossible to differentiate between body fluids;
2. Any unfixed tissue or organ (other than intact skin) from a human (living or dead); and
3. HIV-containing cell or tissue cultures, organ cultures, and HIV- or HBV-containing culture medium or other solutions; and blood, organs, or other tissues from experimental animals infected with HIV or HBV.

Have these materials on hand for cleaning up spills:

- A durable container to store the clean up supplies
- Several biohazard labeled bags
- Disinfectant – freshly-prepared 10% solution of household bleach (1 part bleach and 9 parts water; or add a scant ½ cup bleach to 1 quart of water) or other commercial chlorine or iodine based disinfectant)
- Inert absorbing material (e.g., diatomaceous earth, hy-dri, kitty litter, absorbent pads)
- A small dust pan and hand brush
- Personal protective equipment, including several pairs of latex gloves, goggles, face
- masks, coveralls, and paper boots
- A heavy cardboard box
- A roll of paper towels
- Antiseptic wipes

Follow these procedures if you are cleaning up a spill of blood or OPIM:

- If blood or PIM has spilled directly onto you, it should be thoroughly washed off as soon as possible. If the material has spilled on your clothing and soaked through so that there is skin contact, the clothes must be removed. Following removal, wash those areas where exposure is evident, even to the point of taking a shower. If blood or PIM has come into contact with any of the mucous membranes (eyes, nose, lips) they need to be thoroughly rinsed. If there is contact with open wounds or cracks in the skin, there is a risk of exposure. Immediately and thoroughly wash your hands with water and an antiseptic cleaner if contaminated with a body fluid. These occurrences are considered to be an Exposure Incident and it is important to follow the procedure outlined in the Bloodborne Pathogen/Exposure Control Plan.

2

- When clean up involves blood or PIM that is on a flat surface, you should first delineate and mark the spill area so that others do not inadvertently enter the area until clean up is complete.
- Don personal protective equipment before beginning clean up. Minimal PPE consists of gloves, goggles, mask, and coveralls or other outer garment.
- Small spills should be wiped up with paper towels, then decontaminated with a proper disinfectant. Spill kits designed for cleaning up small spills (less than 8 ounces) of potentially infectious material are commercially available.
- Large spills can be quickly contained by creating a circular berm around the perimeter of the spill with an absorbent material (hy-dri, kitty litter, diatomaceous earth). Residual liquids in the center of the ring can be soaked up with additional absorbent or absorbent pads. Place the absorbent in a biohazard waste bag.
- Soak the area for at least 20 minutes with a disinfectant (freshly-prepared 10% bleach solution). You can be liberal with disinfectant but don't apply so heavily that it begins to run.
- Allow at least 20 minutes for the disinfectant to complete the decontamination. You can use the small hand broom and dustpan to clean up the spill.
- Deposit all clean up material in biowaste disposal bag and close tightly. The bag should be secured in a Biohazard Burnbox. Carefully remove gloves, coveralls, and boots, (if used) and discard in a biowaste bag. If used, the facemask should also be disposed. Goggles can be disinfected, rinsed and reused.
- The dustpan and broom can also be disinfected, rinsed, air-dried and reused.
- After cleaning and disinfecting your equipment, return them to their proper storage area. Replace PPE, bags, and other items so that they will be available for future use.



**Waste Management
Inc.
Healthcare Solutions**

SPILL KIT INVENTORY

PLEASE KEEP A COPY OF THIS IN EACH VEHICLE BINDER, AS WELL AS IN EVERY SPILL KIT. IF A PRODUCT IS USED FROM THE SPILL KIT, CHECK THE APPROPRIATE BOX BELOW AND RETURN THIS FORM TO YOUR SUPERVISOR. REPLACE WITH NEW FORM WHEN ANY PRODUCT IS REMOVED FROM WITHIN SPILL KIT. IF OUTER SEAL IS BROKEN, PLEASE CHECK SPILL KIT INVENTORY AND COMPLETE THIS FORM.

| Spill Kit | Sealed: Y or N | Replace (✓) |
|--|----------------|---------------|
| Barricade Tape | | |
| Disinfectant | | |
| 3 Respirator Masks | | |
| Masking Tape (duct tape) | | |
| 6 pair of Nitrile Gloves | | |
| 1 Biohazard Sticker | | |
| Sharps Container | | |
| Dust Pan | | |
| Broom | | |
| Tongs | | |
| Red Bags | | |
| Absorbent Pad | | |
| Paper Towel Roll | | |
| Coverall | | |
| Bleach/ water mixture (store outside of spill kit) | | |
| Faceshield | | |
| Heavy Rubber Gloves | | |
| First-aid Kit | | |
| Germicidal Antibacterial Hand Sanitizer | | |
| Flashlight and Batteries | | |
| Safety Security Seal on exterior of the Spill Kit | | |

Exhibit 6

ACORD

CERTIFICATE OF LIABILITY INSURANCE

1/1/2013

DATE (MM/DD/YYYY)
6/22/2012

THIS CERTIFICATE IS ISSUED AS A MATTER OF INFORMATION ONLY AND CONFERS NO RIGHTS UPON THE CERTIFICATE HOLDER. THIS CERTIFICATE DOES NOT AFFIRMATIVELY OR NEGATIVELY AMEND, EXTEND OR ALTER THE COVERAGE AFFORDED BY THE POLICIES BELOW. THIS CERTIFICATE OF INSURANCE DOES NOT CONSTITUTE A CONTRACT BETWEEN THE ISSUING INSURER(S), AUTHORIZED REPRESENTATIVE OR PRODUCER, AND THE CERTIFICATE HOLDER.

IMPORTANT: If the certificate holder is an ADDITIONAL INSURED, the policy(ies) must be endorsed. If SUBROGATION IS WAIVED, subject to the terms and conditions of the policy, certain policies may require an endorsement. A statement on this certificate does not confer rights to the certificate holder in lieu of such endorsement(s).

| PRODUCER LOCKTON COMPANIES, LLC 5847 SAN FELIPE, SUITE 320 HOUSTON TX 77057 866-260-3538 | CONTACT NAME: PHONE (A/C, No, Ext): FAX (A/C, No): E-MAIL ADDRESS: | | | | | | | | | | | | | |
|---|--|-------------------------------|--------|---|-------|--|-------|---|-------|------------|--|------------|--|------------|
| | <table border="1"> <thead> <tr> <th>INSURER(S) AFFORDING COVERAGE</th> <th>NAIC #</th> </tr> </thead> <tbody> <tr> <td>INSURER A: ACE American Insurance Company</td> <td>22667</td> </tr> <tr> <td>INSURER B: Indemnity Insurance Co of North America</td> <td>43575</td> </tr> <tr> <td>INSURER C: ACE Property & Casualty Insurance Co</td> <td>20699</td> </tr> <tr> <td>INSURER D:</td> <td></td> </tr> <tr> <td>INSURER E:</td> <td></td> </tr> <tr> <td>INSURER F:</td> <td></td> </tr> </tbody> </table> | INSURER(S) AFFORDING COVERAGE | NAIC # | INSURER A: ACE American Insurance Company | 22667 | INSURER B: Indemnity Insurance Co of North America | 43575 | INSURER C: ACE Property & Casualty Insurance Co | 20699 | INSURER D: | | INSURER E: | | INSURER F: |
| INSURER(S) AFFORDING COVERAGE | NAIC # | | | | | | | | | | | | | |
| INSURER A: ACE American Insurance Company | 22667 | | | | | | | | | | | | | |
| INSURER B: Indemnity Insurance Co of North America | 43575 | | | | | | | | | | | | | |
| INSURER C: ACE Property & Casualty Insurance Co | 20699 | | | | | | | | | | | | | |
| INSURER D: | | | | | | | | | | | | | | |
| INSURER E: | | | | | | | | | | | | | | |
| INSURER F: | | | | | | | | | | | | | | |
| INSURED 1300299 WASTE MANAGEMENT HOLDINGS, INC. & ALL AFFILIATED, RELATED & SUBSIDIARY COMPANIES INCLUDING: WM HEALTHCARE SOLUTIONS 8101 1ST AVENUE SOUTH SEATTLE WA 98108 | | | | | | | | | | | | | | |

COVERAGES WAKIRKLA AJ CERTIFICATE NUMBER: 11892581 REVISION NUMBER: XXXXXXXX

THIS IS TO CERTIFY THAT THE POLICIES OF INSURANCE LISTED BELOW HAVE BEEN ISSUED TO THE INSURED NAMED ABOVE FOR THE POLICY PERIOD INDICATED. NOTWITHSTANDING ANY REQUIREMENT, TERM OR CONDITION OF ANY CONTRACT OR OTHER DOCUMENT WITH RESPECT TO WHICH THIS CERTIFICATE MAY BE ISSUED OR MAY PERTAIN, THE INSURANCE AFFORDED BY THE POLICIES DESCRIBED HEREIN IS SUBJECT TO ALL THE TERMS, EXCLUSIONS AND CONDITIONS OF SUCH POLICIES. LIMITS SHOWN MAY HAVE BEEN REDUCED BY PAID CLAIMS.

| INSR LTR | TYPE OF INSURANCE | ADDL INSR | SUBR WVD | POLICY NUMBER | POLICY EFF (MM/DD/YYYY) | POLICY EXP (MM/DD/YYYY) | LIMITS |
|-------------|---|-----------|----------|--|----------------------------------|----------------------------------|---|
| A | GENERAL LIABILITY <input checked="" type="checkbox"/> COMMERCIAL GENERAL LIABILITY <input type="checkbox"/> CLAIMS-MADE <input checked="" type="checkbox"/> OCCUR <input checked="" type="checkbox"/> XCU INCLUDED <input checked="" type="checkbox"/> ISO FORM CG 00011207 GEN'L AGGREGATE LIMIT APPLIES PER: <input type="checkbox"/> POLICY <input checked="" type="checkbox"/> PROJECT <input checked="" type="checkbox"/> LOC | Y | Y | HDO G26436886 | 1/1/2012 | 1/1/2013 | EACH OCCURRENCE \$ 5,000,000 DAMAGE TO RENTED PREMISES (Ea occurrence) \$ 5,000,000 MED EXP (Any one person) \$ XXXXXXXX PERSONAL & ADV INJURY \$ 5,000,000 GENERAL AGGREGATE \$ 6,000,000 PRODUCTS - COMP/OP AGG \$ 6,000,000 |
| A | AUTOMOBILE LIABILITY <input checked="" type="checkbox"/> ANY AUTO <input checked="" type="checkbox"/> ALL OWNED AUTOS <input checked="" type="checkbox"/> HIRED AUTOS <input checked="" type="checkbox"/> MCS-90 <input type="checkbox"/> SCHEDULED AUTOS <input checked="" type="checkbox"/> NON-OWNED AUTOS | Y | Y | MMT H08692853 | 1/1/2012 | 1/1/2013 | COMBINED SINGLE LIMIT (Ea accident) \$ 1,000,000 BODILY INJURY (Per person) \$ XXXXXXXX BODILY INJURY (Per accident) \$ XXXXXXXX PROPERTY DAMAGE (Per accident) \$ XXXXXXXX |
| C | <input checked="" type="checkbox"/> UMBRELLA LIAB <input checked="" type="checkbox"/> EXCESS LIAB <input checked="" type="checkbox"/> OCCUR <input type="checkbox"/> CLAIMS-MADE DED RETENTION \$ | Y | Y | XOO G25834501 | 1/1/2012 | 1/1/2013 | EACH OCCURRENCE \$ 15,000,000 AGGREGATE \$ 15,000,000 |
| B A A | WORKERS COMPENSATION AND EMPLOYERS' LIABILITY ANY PROPRIETOR/PARTNER/EXECUTIVE OFFICER/MEMBER EXCLUDED? (Mandatory in Nn) If yes, describe under DESCRIPTION OF OPERATIONS below | Y/N N | Y N/A | WLR C46774735 (AOS) WLR C46774747 (CA & MA) SCF C4677579A (WI) | 1/1/2012 1/1/2012 1/1/2012 | 1/1/2013 1/1/2013 1/1/2013 | <input checked="" type="checkbox"/> WC STATUTORY LIMITS OTH-ER EL EACH ACCIDENT \$ 3,000,000 EL DISEASE - EA EMPLOYEE \$ 3,000,000 EL DISEASE - POLICY LIMIT \$ 3,000,000 |
| A | EXCESS AUTO LIABILITY | Y | Y | XTR H08692865 | 1/1/2012 | 1/1/2013 | COMBINED SINGLE LIMIT \$9,000,000 (EACH ACCIDENT) |

DESCRIPTION OF OPERATIONS / LOCATIONS / VEHICLES (Attach ACORD 101, Additional Remarks Schedule, if more space is required)
 BLANKET WAIVER OF SUBROGATION IS GRANTED IN FAVOR OF CERTIFICATE HOLDER ON ALL POLICIES WHERE AND TO THE EXTENT REQUIRED BY WRITTEN CONTRACT WHERE PERMISSIBLE BY LAW. CERTIFICATE HOLDER IS NAMED AS AN ADDITIONAL INSURED (EXCEPT FOR WORKERS' COMP/EL) WHERE AND TO THE EXTENT REQUIRED BY WRITTEN CONTRACT.

CERTIFICATE HOLDER

CANCELLATION

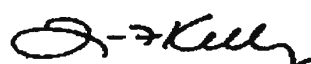
| | |
|---|---|
| 11892581 FOR INFORMATIONAL PURPOSES ONLY | SHOULD ANY OF THE ABOVE DESCRIBED POLICIES BE CANCELLED BEFORE THE EXPIRATION DATE THEREOF, NOTICE WILL BE DELIVERED IN ACCORDANCE WITH THE POLICY PROVISIONS. AUTHORIZED REPRESENTATIVE  |
|---|---|

ACORD 25 (2010/06)

© 1988-2010 ACORD CORPORATION. All rights reserved

The ACORD name and logo are registered marks of ACORD

WM000130



CERTIFICATE OF LIABILITY INSURANCE

DATE (MM/DD/YYYY)
06/22/2012

THIS CERTIFICATE IS ISSUED AS A MATTER OF INFORMATION ONLY AND CONFERS NO RIGHTS UPON THE CERTIFICATE HOLDER. THIS CERTIFICATE DOES NOT AFFIRMATIVELY OR NEGATIVELY AMEND, EXTEND OR ALTER THE COVERAGE AFFORDED BY THE POLICIES BELOW. THIS CERTIFICATE OF INSURANCE DOES NOT CONSTITUTE A CONTRACT BETWEEN THE ISSUING INSURER(S), AUTHORIZED REPRESENTATIVE OR PRODUCER, AND THE CERTIFICATE HOLDER.

IMPORTANT: If the certificate holder is an ADDITIONAL INSURED, the policy(ies) must be endorsed. If SUBROGATION IS WAIVED, subject to the terms and conditions of the policy, certain policies may require an endorsement. A statement on this certificate does not confer rights to the certificate holder in lieu of such endorsement(s).

| | | | |
|---|---|-----------------------|---------------|
| PRODUCER Marsh USA Inc. 1000 Main Street, Suite 3000 Houston, TX 77002 | CONTACT NAME: | | |
| | PHONE (A/C, No, Ext): | FAX (A/C, No): | |
| E-MAIL ADDRESS: | | | |
| INSURED WMI --P1020-11-14 WASTE MANAGEMENT OF WASHINGTON, INC. 8111 FIRST AVENUE SOUTH SEATTLE, WA 98108 | INSURER(S) AFFORDING COVERAGE | | NAIC # |
| | INSURER A: Chartis Specialty Insurance Co. | | 26883 |
| | INSURER B: | | |
| | INSURER C: | | |
| | INSURER D: | | |
| | INSURER E: | | |
| INSURER F: | | | |

| | | |
|------------------|---|-------------------------|
| COVERAGES | CERTIFICATE NUMBER: HOU-002168475-01 | REVISION NUMBER: |
|------------------|---|-------------------------|

THIS IS TO CERTIFY THAT THE POLICIES OF INSURANCE LISTED BELOW HAVE BEEN ISSUED TO THE INSURED NAMED ABOVE FOR THE POLICY PERIOD INDICATED. NOTWITHSTANDING ANY REQUIREMENT, TERM OR CONDITION OF ANY CONTRACT OR OTHER DOCUMENT WITH RESPECT TO WHICH THIS CERTIFICATE MAY BE ISSUED OR MAY PERTAIN, THE INSURANCE AFFORDED BY THE POLICIES DESCRIBED HEREIN IS SUBJECT TO ALL THE TERMS, EXCLUSIONS AND CONDITIONS OF SUCH POLICIES. LIMITS SHOWN MAY HAVE BEEN REDUCED BY PAID CLAIMS.

| INSR LTR | TYPE OF INSURANCE | ADDL INSR | SUBR WVR | POLICY NUMBER | POLICY EFF (MM/DD/YYYY) | POLICY EXP (MM/DD/YYYY) | LIMITS |
|----------|--|---|---|---------------|-------------------------|-------------------------|--|
| | GENERAL LIABILITY <input type="checkbox"/> COMMERCIAL GENERAL LIABILITY <input type="checkbox"/> CLAIMS-MADE <input type="checkbox"/> OCCUR GEN'L AGGREGATE LIMIT APPLIES PER: <input type="checkbox"/> POLICY <input type="checkbox"/> PRO-JECT <input type="checkbox"/> LOC | | | | | | EACH OCCURRENCE \$ DAMAGE TO RENTED PREMISES (Ea occurrence) \$ MED EXP (Any one person) \$ PERSONAL & ADV INJURY \$ GENERAL AGGREGATE \$ PRODUCTS - COMP/OP AGG \$ \$ |
| | AUTOMOBILE LIABILITY <input type="checkbox"/> ANY AUTO <input type="checkbox"/> ALL OWNED AUTOS <input type="checkbox"/> HIRED AUTOS <input type="checkbox"/> SCHEDULED AUTOS <input type="checkbox"/> NON-OWNED AUTOS | | | | | | COMBINED SINGLE LIMIT (Ea accident) \$ BODILY INJURY (Per person) \$ BODILY INJURY (Per accident) \$ PROPERTY DAMAGE (Per accident) \$ \$ |
| | <input type="checkbox"/> UMBRELLA LIAB <input type="checkbox"/> EXCESS LIAB <input type="checkbox"/> DED <input type="checkbox"/> RETENTION \$ <input type="checkbox"/> OCCUR <input type="checkbox"/> CLAIMS-MADE | | | | | | EACH OCCURRENCE \$ AGGREGATE \$ \$ |
| | WORKERS COMPENSATION AND EMPLOYERS' LIABILITY ANY PROPRIETOR/PARTNER/EXECUTIVE OFFICER/MEMBER EXCLUDED? (Mandatory In NH) If yes, describe under DESCRIPTION OF OPERATIONS below | <input type="checkbox"/> Y <input checked="" type="checkbox"/> N | <input type="checkbox"/> N <input checked="" type="checkbox"/> A | | | | WC STATU-TORY LIMITS OTH-ER E.L. EACH ACCIDENT \$ E.L. DISEASE - EA EMPLOYEE \$ E.L. DISEASE - POLICY LIMIT \$ |
| A | Pollution Legal Liability | | | PLS 5444079 | 01/01/2011 | 01/01/2014 | Each Incident Limit 10,000,000 Aggregate Limit 20,000,000 |

DESCRIPTION OF OPERATIONS / LOCATIONS / VEHICLES (Attach ACORD 101, Additional Remarks Schedule, if more space is required)

| | |
|--|--|
| CERTIFICATE HOLDER Waste Management of Washington, Inc. 8111 1st Ave So. Seattle, WA 98108 | CANCELLATION SHOULD ANY OF THE ABOVE DESCRIBED POLICIES BE CANCELLED BEFORE THE EXPIRATION DATE THEREOF, NOTICE WILL BE DELIVERED IN ACCORDANCE WITH THE POLICY PROVISIONS. AUTHORIZED REPRESENTATIVE of Marsh USA Inc. Stephanie S. Story |
|--|--|

AGENCY CUSTOMER ID: WMI

LOC #: Houston



ADDITIONAL REMARKS SCHEDULE

Page 2 of 2

| | | | |
|--------------------------|-----------|---|--|
| AGENCY Marsh USA Inc. | | NAMED INSURED WASTE MANAGEMENT OF WASHINGTON, INC. 8111 FIRST AVENUE SOUTH SEATTLE, WA 98108 | |
| POLICY NUMBER | | EFFECTIVE DATE: | |
| CARRIER | NAIC CODE | | |

ADDITIONAL REMARKS

THIS ADDITIONAL REMARKS FORM IS A SCHEDULE TO ACORD FORM,
FORM NUMBER: 25 FORM TITLE: Certificate of Liability Insurance

Pollution Legal Liability continued:

Aggregate Limit is excess the SIR.
Self Insured Retention Limit - \$5,000,000

Exhibit 7



CERTIFICATE OF LIABILITY INSURANCE

DATE (MM/DD/YYYY)
05/14/2012

THIS CERTIFICATE IS ISSUED AS A MATTER OF INFORMATION ONLY AND CONFERS NO RIGHTS UPON THE CERTIFICATE HOLDER. THIS CERTIFICATE DOES NOT AFFIRMATIVELY OR NEGATIVELY AMEND, EXTEND OR ALTER THE COVERAGE AFFORDED BY THE POLICIES BELOW. THIS CERTIFICATE OF INSURANCE DOES NOT CONSTITUTE A CONTRACT BETWEEN THE ISSUING INSURER(S), AUTHORIZED REPRESENTATIVE OR PRODUCER, AND THE CERTIFICATE HOLDER.

IMPORTANT: If the certificate holder is an ADDITIONAL INSURED, the policy(ies) must be endorsed. If SUBROGATION IS WAIVED, subject to the terms and conditions of the policy, certain policies may require an endorsement. A statement on this certificate does not confer rights to the certificate holder in lieu of such endorsement(s).

| PRODUCER MARSH USA INC. 540 W. MADISON CHICAGO, IL 60661 Attn: Chicago.CertRequest@marsh.com | | CONTACT NAME: PHONE (A/C, No, Ext): | FAX (A/C, No): | | | | | | | | | | | | | | |
|---|--------|--|-----------------------|-------------------------------|--------|----------------------|-------|-------------------|-------|---------------------------------|-------|---------------------------|-------|-------------------|-------|-------------------------|-------|
| 350208-ALL1-wPOLL-11-13 | | <table border="1"> <tr> <th>INSURER(S) AFFORDING COVERAGE</th> <th>NAIC #</th> </tr> <tr> <td>an Insurance Company</td> <td>19437</td> </tr> <tr> <td>Fire Insurance Co</td> <td>19682</td> </tr> <tr> <td>orld National Assurance Company</td> <td>10690</td> </tr> <tr> <td>Insurance Company Of Midw</td> <td>37478</td> </tr> <tr> <td>Fire Insurance Co</td> <td>29459</td> </tr> <tr> <td>Insurance Company Of SE</td> <td>38261</td> </tr> </table> | | INSURER(S) AFFORDING COVERAGE | NAIC # | an Insurance Company | 19437 | Fire Insurance Co | 19682 | orld National Assurance Company | 10690 | Insurance Company Of Midw | 37478 | Fire Insurance Co | 29459 | Insurance Company Of SE | 38261 |
| INSURER(S) AFFORDING COVERAGE | NAIC # | | | | | | | | | | | | | | | | |
| an Insurance Company | 19437 | | | | | | | | | | | | | | | | |
| Fire Insurance Co | 19682 | | | | | | | | | | | | | | | | |
| orld National Assurance Company | 10690 | | | | | | | | | | | | | | | | |
| Insurance Company Of Midw | 37478 | | | | | | | | | | | | | | | | |
| Fire Insurance Co | 29459 | | | | | | | | | | | | | | | | |
| Insurance Company Of SE | 38261 | | | | | | | | | | | | | | | | |
| INSURED STERICYCLE OF WASHINGTON, INC. STERICYCLE, INC. 28161 N. KEITH DRIVE LAKE FOREST, IL 60045 | | | | | | | | | | | | | | | | | |

Please file

COVERAGES CERTIFICATE NUMBER REVISION NUMBER:

THIS IS TO CERTIFY THAT THE POLICIES OF INSURANCE LISTED BELOW HAVE BEEN ISSUED TO THE INSURED NAMED ABOVE FOR THE POLICY PERIOD INDICATED. NOTWITHSTANDING ANY REQUIREMENT, TERM OR CONDITION OF ANY CONTRACT OR OTHER DOCUMENT WITH RESPECT TO WHICH THIS CERTIFICATE MAY BE ISSUED OR MAY PERTAIN, THE INSURANCE AFFORDED BY THE POLICIES DESCRIBED HEREIN IS SUBJECT TO ALL THE TERMS, EXCLUSIONS AND CONDITIONS OF SUCH POLICIES. LIMITS SHOWN MAY HAVE BEEN REDUCED BY PAID CLAIMS.

| INSR LTR | TYPE OF INSURANCE | ADDL SUBR INSR WVD | POLICY NUMBER | POLICY EFF (MM/DD/YYYY) | POLICY EXP (MM/DD/YYYY) | LIMITS |
|----------|---|--------------------|--------------------------------|--------------------------|--------------------------|---|
| A | GENERAL LIABILITY <input checked="" type="checkbox"/> COMMERCIAL GENERAL LIABILITY <input type="checkbox"/> CLAIMS-MADE <input checked="" type="checkbox"/> OCCUR GEN'L AGGREGATE LIMIT APPLIES PER: <input checked="" type="checkbox"/> POLICY <input checked="" type="checkbox"/> PRO-JECT <input checked="" type="checkbox"/> LOC | | | 11/08/2011 | 11/08/2012 | EACH OCCURRENCE \$ 1,000,000 DAMAGE TO RENTED PREMISES (Ea occurrence) \$ 300,000 MED EXP (Any one person) \$ 25,000 PERSONAL & ADV INJURY \$ 1,000,000 GENERAL AGGREGATE \$ 2,000,000 PRODUCTS - COMP/OP AGG \$ 2,000,000 |
| B | AUTOMOBILE LIABILITY <input checked="" type="checkbox"/> ANY AUTO <input type="checkbox"/> ALL OWNED AUTOS <input type="checkbox"/> HIRED AUTOS <input type="checkbox"/> SCHEDULED AUTOS <input type="checkbox"/> NON-OWNED AUTOS | | PHYSICAL DAMAGE - SELF INSURED | 06/01/2012 06/01/2012 | 06/01/2013 06/01/2013 | COMBINED SINGLE LIMIT (Ea accident) \$ 5,000,000 BODILY INJURY (Per person) \$ BODILY INJURY (Per accident) \$ PROPERTY DAMAGE (Per accident) \$ |
| C | <input checked="" type="checkbox"/> UMBRELLA LIAB <input checked="" type="checkbox"/> OCCUR <input type="checkbox"/> EXCESS LIAB <input type="checkbox"/> CLAIMS-MADE DED <input checked="" type="checkbox"/> RETENTION \$ 10,000 | | | 11/08/2011 | 11/08/2012 | EACH OCCURRENCE \$ 5,000,000 AGGREGATE \$ 5,000,000 |
| D | WORKERS COMPENSATION AND EMPLOYERS' LIABILITY | | | 06/01/2012 | 06/01/2013 | <input checked="" type="checkbox"/> WC STATU-TORY LIMITS <input type="checkbox"/> OTH-ER |
| E | ANY PROPRIETOR/PARTNER/EXECUTIVE OFFICER/MEMBER EXCLUDED? (Mandatory in NH) | Y/N | | 06/01/2012 | 06/01/2013 | E.L. EACH ACCIDENT \$ 1,000,000 |
| F | If yes, describe under DESCRIPTION OF OPERATIONS below | N/A | | 06/01/2012 | 06/01/2013 | E.L. DISEASE - EA EMPLOYEE \$ 1,000,000 E.L. DISEASE - POLICY LIMIT \$ 1,000,000 |
| A | Pollution Legal Liability | | | 11/08/2011 | 06/01/2014 | EACH OCCURRENCE 10,000,000 GENERAL AGGREGATE 10,000,000 |

DESCRIPTION OF OPERATIONS / LOCATIONS / VEHICLES (Attach ACORD 101, Additional Remarks Schedule, if more space is required)

CERTIFICATE HOLDER CANCELLATION

| | | |
|--|------|--|
| Seattle-King County Public Health 401 Fifth Ave., Suite 1100 Seattle, WA 98104 | | SHOULD ANY OF THE ABOVE DESCRIBED POLICIES BE CANCELLED BEFORE THE EXPIRATION DATE THEREOF, NOTICE WILL BE DELIVERED IN ACCORDANCE WITH THE POLICY PROVISIONS. |
| | | AUTHORIZED REPRESENTATIVE of Marsh USA Inc. Manashi Mukherjee <i>Manashi Mukherjee</i> |

AGENCY CUSTOMER ID: 350208

LOC #: Chicago



ADDITIONAL REMARKS SCHEDULE

Page 2 of 2

| | | | |
|--------------------------|-----------|--|--|
| AGENCY MARSH USA INC. | | NAMED INSURED STERICYCLE OF WASHINGTON, INC. STERICYCLE, INC. 28161 N. KEITH DRIVE LAKE FOREST, IL 60045 | |
| POLICY NUMBER | | EFFECTIVE DATE: | |
| CARRIER | NAIC CODE | | |

ADDITIONAL REMARKS

THIS ADDITIONAL REMARKS FORM IS A SCHEDULE TO ACORD FORM,
FORM NUMBER: 25 FORM TITLE: Certificate of Liability Insurance

Additional Workers Compensation Policies:

Insurer: Hartford Fire Insurance Company
Policy Number: 83 WN S13400 (CO, GA, IA, ND, NE, NV, OH, WA)
Effective Date: 06/01/2012
Expiration Date: 06/01/2013

Insurer: Hartford Casualty Insurance Company
Policy Number: 83 WN S13400 (AL, MN, NC, VA)
Effective Date: 06/01/2012
Expiration Date: 06/01/2013

Insurer: Hartford Accident and Indemnity Co.
Policy Number: 83 WN S13400 (CA, CT, KY, MO, MS, MT, OR, WV)
Effective Date: 06/01/2012
Expiration Date: 06/01/2013

Insurer: Twin City Fire Insurance Company
Policy Number: 83 WBR S13401 (WI)
Effective Date: 06/01/2012
Expiration Date: 06/01/2013

Exhibit 8

April 9, 2012

Bill Lasby
Supervisor, Solid Waste
Environmental Health Services Division
Environmental Hazards Section
Seattle & King County Public Health
401 Fifth Avenue, Suite 1100
Seattle, WA 98104-1818

**Re: ANNUAL REPORT FOR
SEATTLE BIOMEDICAL WASTE TREATMENT FACILITY
SOLID WASTE FACILITY PERMIT # PR0080378**

Dear Mr. Lasby,

Pursuant to Section 4 (C of the above-referenced permit, below is information for our 2011 Annual Report.

1. **Name/Address of Facility:** Seattle BMW Treatment Facility 149 SW Kenyon St., Seattle, WA 98108
2. **Calendar Year Covered:** 2011.
3. **Annual Quantity and Type of Biomedical Waste; in Pounds or Gallons:** 317,197.10 lbs. processed in 2011. Type of Biomedical Waste is as defined in King County Title 10, 10.04.020 part D. Pathological and residual chemotherapy wastes are collected in segregated containers and shipped out of State for processing.
4. **Type of Final Disposition by Type of Waste:** Greater Wenatchee Landfill. 191 Webb Road, Wenatchee, WA 98802.
5. **Facility Activities during 2011:** Installation of a new 21' autoclave, boiler, tub tippers and tub sanitizing system completed June 2011.

Sincerely,

Jeff Daub
Senior District Manager

WM000698

Exhibit 9

**WM Healthcare Solutions, Inc. (WMHS)
Biomedical Waste Operating Plan**

For

**Waste Management of Washington, Inc.
Seattle Biomedical Waste Treatment Facility
149 SW Kenyon Street, Seattle, WA 98108**

June, 2011



**Biomedical Waste Operating Plan
Table of Contents**

- i. Executive Officer Endorsement Letter - 3
1. Definition of Waste Accepted - 4
2. Sources Of Biomedical Wastes - 5
3. Biomedical Waste Transportation/Containment/Storage/Treatment
 - a. Transportation - 8
 - b. Containment - 10
 - c. Storage - 12
 - d. Treatment - 14
4. Operation
 - a. Steam Sterilization - 16
 - b. Sharps Treatment- 18
 - c. Audit Procedures of Critical Equipment - 19
5. Contingency Plan and Emergency Procedures
 - a. Back-up Facilities - 19
 - b. Fire Procedures - 20
 - c. Spill Response - 21
 - Liquid Spills Procedures - 21
 - Dry Spills Procedures - 21
 - d. Explosion - 22
 - e. Equipment Failure - 22
 - f. Spill Containment Equipment - 22
6. Supervision and Staffing - 22
7. Training Program - 24
8. Record-Keeping - 24

Appendices

- Appendix A: Site Map, Treatment Facility Floor Diagram, Process Flow Schematic
- Appendix B: Medical Waste Tracking Document
- Appendix C: Reusable Container Washing/Decon Procedure
- Appendix D: Waste Acceptance Protocol
- Appendix E: Training Matrix
- Appendix F: PPE Requirements
- Appendix G: Sterilizer Units Design Information
- Appendix H: Sharps Processing Unit Manufacturer Information
- Appendix I: Emergency Action Plan

Executive Officer Endorsement Letter

WM Healthcare Solutions, Inc. (WMHS)
Biomedical Waste Operating Plan for

Waste Management of Washington, Inc.
Seattle Biomedical Waste Treatment Facility

Address: 149 SW Kenyon St.
Seattle, WA 98108

1. Waste Accepted

Seattle Biomedical Waste Treatment Facility (the Facility) accepts the following types of wastes for treatment and/or transfer:

a) Pathological and Trace Chemotherapy:

- "Pathological waste" is waste human source biopsy materials, tissues, and anatomical parts that emanate from surgery, obstetrical procedures, and autopsy. "Pathological waste" does not include teeth, human corpses, remains, and anatomical parts that are intended for interment or cremation.
- "Cultures and stocks" are wastes infectious to humans and includes specimen cultures, cultures and stocks of etiologic agents, wastes from production of biologicals and serums, discarded live and attenuated vaccines, and laboratory waste that has come into contact with cultures and stocks of etiologic agents or blood specimens. Such waste includes but is not limited to culture dishes, blood
- Specimen tubes, and devices used to transfer, inoculate, and mix cultures.
- This waste includes animal waste exposed to pathogens and trace chemotherapy.

b) Medical Waste:

- "Human blood and blood products" is discarded waste human blood and blood components, and materials containing free-flowing blood and blood products.
- "Animal waste" is waste animal carcasses, body parts, and bedding of animals that are known to be infected with, or that have been inoculated with, human pathogenic microorganisms infectious to humans.

c) Sharps:

"Sharps waste" is all hypodermic needles, syringes with needles attached, IV tubing with needles attached, scalpel blades, and lancets that have been removed from the original sterile package.

d) Non-hazardous Pharmaceuticals:

- **"Non-hazardous Pharmaceuticals" are Non-RCRA only pharmaceuticals including controlled substances prescription drugs and over the counter (OTC) medications.**
- **Non-RCRA Pharmaceuticals exempted under the Conditional Exclusion.**

All accepted waste will be properly packaged and labeled for the facility. All waste accepted for the facility is in accordance with the Waste Acceptance Protocol (Appendix D). Waste material received at the facility not meeting the specified medical waste acceptance guidelines will be refrigerated and return to the customer. Customers, as part of the on-boarding, will get training and education. The Plant Manager contacts customers to interface on operational issues that arise from improper packaging, improper materials etc. All biomedical waste received at the facility will have a four part waste tracking document (Appendix B).

2. Sources of Waste:

Biomedical waste generators includes without limitation, the following: general acute care hospitals, skilled nursing facility or convalescent hospitals, intermediate care facilities, in-patient care facilities for the developmentally disabled, chronic dialysis clinics, community clinics, health maintenance organizations, surgical clinics, urgent care clinics, acute psychiatric hospitals, laboratories, medical buildings, physicians' offices and clinics, veterinary offices and clinics, dental offices and clinics, funeral homes, or other similar facilities.

Only biomedical wastes meeting the Facility's Waste Acceptance Protocol will be accepted.

3. Waste Transportation/Containment/Storage/Transfer/Treatment Operation:

The following matrix summarizes methods/procedures for Containment, Storage, Transfer, Treatment and Disposal for wastes accepted by the Facility:

THIS SECTION IS INTENTIONALLY LEFT BLANK

| Waste Type | Containment | Storage | Treatment | Post-Treatment Waste Handling (Prior to Disposal) | Disposal |
|--|--|--|---------------------|--|----------------------|
| Pathological and Trace Chemotherapy | <p>Sealed, leak-proof, labeled plastic bags or containers collected in Over-pack Containers provided by the Facility.</p> <p>Over-packs are: plastic reusable boxes/drums; cardboard boxes; or fiber drums.</p> | <p>Refrigerated trailer, until treatment.</p> <p>Collected waste is transported to the Facility and consolidated in the trailer. When full, the trailer is hauled to the treatment facility.</p> <p>Maximum Hold Time: 90 days.</p> | Incineration | Residual waste from the incinerator is collected into bins. Full bins are loaded on a truck and hauled to the landfill | Landfill (Residuals) |
| Biomedical Waste (excluding Pathological, Chemotherapy, and Non-hazardous Pharmaceuticals) | <p>Sealed, rigid, puncture-proof, labeled containers collected in over-pack containers provided by the Facility.</p> <p>Over-packs are: Reusable plastic pails, bins, boxes or drums; or cardboard boxes or fiber drums.</p> | <p>Over-packs transported to the Facility that are not immediately loaded into the sterilizer are placed in the designated "Untreated BMW Storage Area" location identified on the Floor Plan (Figure 2).</p> <p>Maximum Hold Time: 15 days (Unrefrigerated); 90 days (Refrigerated)</p> | Steam Sterilization | Waste is hauled to Eastmont TS, comingled with MSW and compacted, then loaded into intermodal containers for rail transport to the landfill. | Landfill |
| Sharps | <p>Sealed, rigid, puncture-proof, labeled containers collected in over-pack containers provided by the Facility.</p> <p>Over-packs are: Reusable plastic pails, bins, boxes or drums; or cardboard boxes or fiber drums.</p> | <p>Over-packs transported to the Facility that are not immediately loaded into the sterilizer are placed in a designated Pretreatment Holding Area.</p> <p>Maximum Hold Time: 15 days (Unrefrigerated); 90 days (Refrigerated)</p> | Steam Sterilization | Waste is hauled to Eastmont TS, comingled with MSW and compacted, then loaded into intermodal containers for rail transport to the landfill. | Landfill |

| Waste Type | Containment | Storage | Treatment | Post-Treatment Waste Handling (Prior to Disposal) | Disposal |
|-------------------------------|---|---|--------------|--|---------------------|
| Non-hazardous Pharmaceuticals | Sealed, leak-proof, labeled containers. | <p>Collected waste is transported to the Facility and consolidated in the trailer. When full, the trailer is hauled to the treatment facility.</p> <p>Maximum Hold Time: 90 days.</p> | Incineration | Residual waste from the incinerator is collected into bins. Full bins are loaded on a truck and hauled to the landfill | Landfill (Residual) |

The following paragraphs detail specific methods/procedures for the above elements.

a. Transportation: Waste will be transported to/from the site in approved registered vehicles leased or owned and operated by the Facility.

Vehicles will be equipped with emergency spill kits containing spill mitigation supplies and clean up equipment. Drivers will be trained in emergency spill response procedures and Bloodborne Pathogens. All transported waste will be properly segregated and contained in leak-proof, rigid containers. Waste will be transported in accordance with local, state, and federal requirements.

In the event of a spill/leak, the vehicle will be decontaminated using an EPA approved disinfectant and the leaking container will be properly labeled and placed in a leak proof over-pack container.

The Facility will maintain a vehicle fleet with design/construction features that meet the following requirements:

- 1) Vehicles used to transport waste will be similar to a panel-side truck (or step van) having a fully enclosed, leak proof container or vehicle compartment;
- 2) Vehicle containers or compartments used to transport waste will be durable and easily cleanable;
- 3) Vehicles shall be identified on each side with the name or trademark of Waste Management; and
- 4) All vehicles will be properly licensed and permitted.

Additionally, the following operational requirements will be followed:

- 1) Vehicles shall be cleaned frequently on the wash pad directly next to the treatment building to prevent rodent/vector and odor nuisances;
- 2) All wastewater from vehicle cleaning shall be disposed of in a sanitary sewer system unless otherwise authorized;
- 3) Biomedical waste shall be delivered for treatment only to the treatment facility; and,
- 4) Surfaces of biomedical waste collection/transportation vehicles that have contacted spilled or leaked biomedical waste shall be decontaminated.

Incoming Pathological, Chemotherapy, and Non-hazardous Pharmaceutical biomedical waste transported to the Facility will be

placed in a refrigerated storage trailer staged on site. When fully loaded, trailers will be hauled to a permitted biomedical incinerator owned and operated by Waste Management (or other non-WM permitted incinerator) to treat this waste. The Facility will maintain a trailer fleet with design/construction features that meet the following requirements:

- 1) Trailer bodies to store/transport waste will be refrigerated, fully enclosed, and have leak proof container or vehicle compartment;
- 2) Trailer containers or compartments used to store/transport waste will be durable and easily cleanable;
- 3) Trailers shall be identified on each side with the name or trademark of Waste Management; and
- 4) All trailers (and cabs) will be properly licensed and permitted.

Additionally, the following operational requirements will be followed for trailers storing/hauling waste incineration-designated waste:

- 1) Trailers shall be cleaned frequently on the wash pad next to the treatment building to prevent rodent/vector and odor nuisances;
- 2) All wastewater from vehicle cleaning shall be disposed of in a sanitary sewer system unless otherwise authorized;
- 3) Biomedical waste shall not be transported in the same vehicle with other waste or medical specimens unless the biomedical waste is contained in a separate, fully enclosed leak proof container within the trailer compartment.
- 4) Biomedical waste shall be delivered for treatment only to the incineration treatment facility; and,
- 5) Surfaces of biomedical waste collection/transportation vehicles that have contacted spilled or leaked biomedical waste shall be decontaminated.

Transportation records documenting all hauling activity of biomedical waste to/from the Facility shall be kept for a period of at least three (3) years, and they shall be available to the health officer upon request.

All waste transported to the facility must be accompanied by an approved medical waste tracking document. An example of an approved medical waste tracking document can be found in Appendix B.

The tracking document will include the following information:

1. Name, address, registration number and telephone number of the waste hauler.
2. Type and quantity of medical waste transported.
3. Generator name, address, and phone number.
4. Name, address, and telephone number of the treatment facility.
5. Authorized signature from the treatment facility.
6. Dates the waste is collected or removed from the generator, dates the waste was deposited and accepted at the Facility.

Methods for Loading and Unloading Waste

Loading Untreated Waste: Only waste meeting the Facility Waste Acceptance Protocol will be loaded. Containers holding accepted waste will be transferred into the transport vehicle by hand, push cart, pallet-jack, or other means. Transport vehicles will have powered rear platforms (e.g., Tommy-Lift gate) to allow containers to be easily and safely elevated from pickup locations into the vehicle. Loaded containers will be placed inside the vehicle in a secure manner so that contents cannot shift/fall during transport.

Unloading Untreated Waste: Loaded waste will be hauled to the Facility after pickup. Waste requiring incineration treatment (pathological, chemotherapy and non-hazardous pharmaceuticals) will be directly transferred from the transport vehicle into the refrigerated storage trailer at the Facility. All other loaded waste will be transferred from the transport vehicle into either: a) An empty metal bin staged inside the Facility for the next treatment batch; or b) A designated refrigerated storage trailer (separate from the refrigerated trailer holding incinerator-destined waste material) until moved into metal bin staged inside the facility for the next treatment batch.

Unloading Treated Waste: Waste treated in the sterilizer will be directly transferred from the sterilizer into an onsite compactor unit. When full, the compactor will be hauled to the transfer station to be emptied. Ground Sharps treated in the grinder-processor unit will either be: 1) Collected in a Gaylord box for recycling. [Filled boxes will be sealed and then put in a dedicated onsite storage trailer. When full, the trailer will transport the treated sharps material to a recycler]; or 2) Collected in a bin and dumped into the onsite compactor unit.

Waste treated in the sterilizer will be directly transferred from the sterilizer bin into an open top 40' intermodal container staged outside of the processing building via rotating forklift. When full,

the trailer will be transported by train to WM's Columbia Ridge landfill located in Arlington, Oregon for final disposition.

b. Containment: Biomedical waste, except for sharps, shall be contained in disposable leakproof plastic bags having a strength to prevent ripping, tearing, breaking or bursting under normal conditions of use. The plastic bags shall be appropriately marked by the generator as containing biomedical waste. The outside of each container must be marked with a water-resistant label displaying the international biohazard symbol, or the words "Biomedical Waste" or other words that clearly denote the presence of biomedical waste. WM offers customers specially marked plastic bags to use for this purpose, or the generator can obtain appropriate bags from other sources.

The plastic bags shall be secured in over-pack containers to prevent leakage or expulsion during storage, handling and transport. Over-packs will be rigid and leak-proof, and may consist of: reusable plastic boxes, lined cardboard-fiber drums, metal or plastic bins, pails, and other containers designed to hold medical waste. Over-pack containers shall be conspicuously marked with a water-resistant label displaying the international biohazard symbol, or the words "Biomedical Waste" or other words that clearly denote the presence of biomedical waste. Secured contained waste will not be mixed with other materials, and access to it will be limited to personnel authorized by WM to handle it.

Reusable containers:

Reusable containers for biomedical waste storage, handling or transport shall be thoroughly washed and decontaminated with an EPA approved anti-microbial and disinfectant. Containers will be washed each time they are used unless they have been protected from contamination by disposable liners, bags or other devices. A Reusable Container Washing/Decon Procedure is contained in Appendix C.

When necessary, reusable containers will be washed at the Facility wash pad area with an EPA approved chemical disinfectant. The chemical concentration and contact time will be used as recommended by the manufacturer. Personnel will wear appropriate PPE including but not limited to safety glasses, gloves, gown or apron, etc. when rinsing contaminated

containers to minimize exposure to chemicals and contaminants. The level of PPE will be determined by the level of exposure.

Employees are trained and follow the Reusable Container Washing/Decon Procedure. Rinse water will be disposed into the sanitary sewer system by Discharge Authorization issued to WM by King County Industrial Waste Program. MSDS's will be maintained for all chemicals used at the Facility.

Sharps shall be contained in leakproof, rigid, puncture resistant, break resistant containers which are labeled and tightly lidded during storage, handling and transport (The outside of each container must be marked with a water-resistant label displaying the international biohazard symbol, or the words "Biomedical Waste" or other words that clearly denote the presence of biomedical waste. WM offers customers specially marked Sharps Containers to use for this purpose, or the generator can obtain appropriate containers from other sources.

Sharps containers shall be secured in over-pack containers to prevent leakage or expulsion during storage, handling and transport. Over-packs will be rigid and leak-proof, and may consist of: reusable plastic boxes, lined cardboard-fiber drums, metal or plastic bins, pails, and other containers designed to hold medical waste. Over-pack containers shall be conspicuously marked with a water-resistant label displaying the international biohazard symbol, or the words "Biomedical Waste" or other words that clearly denote the presence of biomedical waste. Reusable containers used to over-pack sharps containers will be washed and decontaminated as described above.

At the time of pickup, the driver will review the waste load to be picked up to determine if materials are adequately contained and marked. If the load (or portion of a load) is inadequately contained (or marked), the driver will notify the customer the load (or portion) is not acceptable. The customer can: 1) Immediately address noted deficiencies so that the inadequate load (or portion) can be accepted for transport; or 2) Retain the load, address noted deficiencies and reschedule a pick-up. In either case, the driver will note load conditions accordingly on the Medical Waste Tracking Document.

c. Storage: Waste will be stored on site for no more than 15 days, unless it is refrigerated below 32F (waste shall be stored in a non-putrescent state using refrigeration when necessary).

To track onsite waste storage time, dates are placed on containers upon pick-up. In addition, medical waste tracking documents are monitored to ensure that waste storage times do not exceed 15 days. If waste storage requires more than 15 days, the waste will be refrigerated below 32F. The maximum time that refrigerated waste will remain stored onsite is 90 days.

Pathological waste will be transferred directly from the transportation vehicle into a refrigerated unit (trailer or cooler) for storage until shipment to an incinerator for treatment.

The following table summarizes waste storage at the facility.

| Storage Area | Location | For Storage Of | Maximum Storage Time Wastes will remain in the Storage Area |
|---|--|--|---|
| Untreated BMW Storage Area | Dedicated metal bins staged for the next treatment batch inside the BMW Treatment Building | Untreated Biomedical Waste (excluding Pathological, Chemotherapy, and Non-hazardous Pharmaceuticals) and untreated Sharps. | 15 days |
| Refrigerated Storage (below 32 degrees F) Container or box-truck (Dedicated) | Staged, Outside Treatment Building | Untreated Pathological, Chemotherapy, and Non-hazardous Pharmaceuticals | 90 days |
| Refrigerated Storage Container (below 32 degrees F) (Dedicated, separate from the refrigerated container that is used to store BWM held for incineration treatment) | If needed, staged, Outside Treatment Building | Untreated Biomedical Waste (excluding Pathological, Chemotherapy, and Non-hazardous Pharmaceuticals) and untreated Sharps. | 90 days |
| Treated Sharps Container | Staged, Outside Treatment Building | Treated Sharps | 15 days, or until the container is full to haul |

On site storage area(s) shall be kept locked and accessible only to authorized personnel at all times. The storage area shall be conspicuously marked with a sign twelve inches by twelve inches (12" x 12") with the words "Biomedical Waste" and the international biohazard symbol.

Storage of biomedical waste shall be in locked trailers (outside) or within the treatment building (storage locations are identified on

Figure 2; Treatment Facility Floor Plan (Appendix A). The storage area will be protected from animals, rain and wind; does not provide a breeding place or a food source for insects or rodents; and is accessible by authorized personnel. Personnel authorized to enter a storage area are the Facility Manager and technicians trained to manage and operate the treatment operations.

The storage area shall be constructed of finished, impermeable, cleanable materials and be easily maintained in a sanitary condition. Trailers and box trucks interior surfaces (walls, ceilings and floors) will typically be constructed of metal, plastic, fiberglass, or other solid-type surface. Building (interior) storage area surfaces will be constructed of concrete (floors) and metal, plastic, fiberglass, or other solid-type surface (for side walls and ceiling). Exterior storage areas will be located adjacent to the Treatment Facility. Interior storage areas will be in designated area(s) adjacent to the sterilizer. Storage locations are identified on Treatment Facility Floor Diagram (Appendix A).

A spill kit will be located at interior and exterior storage area sites (Spill kit locations are indicated on Figures 1 & 2; Appendix A). Spill kits will contain the following contents: Granulated absorbent material (e.g., floor-dry), plastic bags, shovel; broom, dust pan, liquid disinfectant and PPE (rubber gloves, face shield, and Tyvek suit (incl. booties)).

Biomedical waste shall be segregated from other waste by separate containment from other waste at the point of origin. All biomedical waste and sharps will be secured and stored in over-packs, as described in paragraph (b) above. Accumulated untreated material needed to be stored for treatment at the Facility will be kept at a minimum by maximizing batch sizes to optimize treatment through-put efficiency. Treatment operations will be adjusted accordingly to effectively handle/process incoming untreated material.

d. Treatment: The site will utilize an autoclave, "Steam sterilization", by sterilizing biomedical waste with use of saturated steam within a pressure vessel at temperatures sufficient to kill all microbiological agents in the waste as determined by biological and chemical indicator monitoring requirements.

Biomedical waste as defined in Section 1 shall be treated prior to disposal by one or more of the following methods:

1. Cultures and stocks of etiologic agents and associated biologicals: steam sterilization,

2. Biomedical waste: steam sterilization
3. Sharps: steam sterilization and grinder unit,
4. Pathological waste: incineration, at the Waste Management incinerator or other contracted incinerator.
5. Human blood and body fluids: steam sterilization,
6. Wastes that have come into contact with human body fluids from patients diagnosed with pathogenic organisms: steam sterilization,
7. Animal waste exposed to pathogens in research: at the Waste Management incinerator or other contracted incinerator,
8. Wastes with trace chemotherapy: at the Waste Management incinerator or other contracted incinerator.

The Facility has two steam sterilizer treatment units. Depending on conditions, either sterilizer or both can in operation at the same time. Sterilizer "A" used at the Facility was manufactured by the Turbo Machine Company located in Lansdale, PA. In June, 2005 the unit was upgraded and enlarged by Chemithon Constructors of Seattle, WA to treat international waste at the Port of Seattle from planes and ships arriving from overseas. Alterations consisted of increasing the design capacity of the unit to handle 20 cubic yards of waste material per batch. Sterilizer "B" was manufactured by the Bondtech Corporation and installed in May, 2011. Written Operating Procedures, performance information and details for the steam sterilizers are contained in Appendix G.

Material is loaded into a sterilizer through a large rear opening door. After loading, the sterilizer rear door is sealed shut and connected to a CNG (compressed natural gas) steam boiler for the actual sterilization process. The contents are then sterilized using steam by heating and holding the contents at or above 212F for a minimum of 30 minutes. A temperature record of each sterilizing cycle is created (paper-chart recording) and maintained in the Facility operating record file.

The sterilizers and boiler plant are permitted and registered with the City of Seattle. Operators are certified to run all equipment. Inspections and checks are performed daily on system equipment to ensure proper operation and detect any conditions requiring

unscheduled maintenance or repairs. Routine maintenance is performed on the system.

Following is routine inspection/maintenance activities and schedule for the boiler and steam sterilizers:

- 1) Visually inspect boiler and sterilizers; Inspect boiler water levels and check for water leaks; Check steam lines to sterilizers; Check sterilizer door seals; Sign boiler log-in sheet each day boiler is fired (Daily);
- 2) Blow down boiler; inspect boiler safety auto-shut down (Daily);
- 3) Disconnect UV sensor on boiler to cause auto shut-down feature (Weekly);
- 4) Check pH level of boiler water makeup tank (Weekly);
- 5) Inspect safety relief valves (Monthly);
- 6) Check boiler igniter probe (Monthly);
- 7) Pressure Vessel Inspection on Boiler and Sterilizers (Conducted by City of Seattle, Annually); and,
- 8) Facility & Truck Inspection Checklist (Monthly)

Untreated biomedical waste streams designated above for incinerator treatment will be transported in an approved vehicle by an approved/permitted hauler to either Waste Management's Resource Recovery & Recycling Center (WMRRC), located at 7505 State Highway 65, Chambers County, Anahuac, TX 77514 or another approved incinerator for treatment such as Convanta Marion, Inc., located at 4850 Brooklake Road, NE, Brooks, OR 97305.

WMRRC is the Southwest's largest incendiary unit serving large industries, government agencies, small business and individuals. This facility meets all federal, state and local permit requirements. Destruction services are performed efficiently and supervised carefully by highly trained technicians whose capabilities meet or exceed standards set by the American Society of Mechanical Engineers. WMRRC is permitted to treat the following types of biomedical wastes: Regulated Medical Waste (Bio-hazardous); DEA/Regulated Substances; Non-hazardous Pharmaceuticals; Non-hazardous Industrial Waste; Pathology Waste; Chemotherapy Waste (Trace Concentrations); and sharps.

4. Operation: Accepted waste is treated by one of two treatment operations, depending on waste type. Non-sharps waste will be treated by steam sterilization in the Facility sterilizer unit; Sharps are steam-treated, and may then be ground into unrecognizable pieces in a self-contained processing unit. These operational treatment processes are described below in detail. Facility

employees are required to wear designated PPE when performing work operations and activities. A PPE matrix is contained in Appendix F.

a. Steam Sterilization Treatment (for Non-Sharps): The Facility uses two steam sterilizers for treatment. Each sterilizer is able to process up to approximately one ton of medical waste per hour of operation. A maximum of 16 tons total per day of biomedical waste will be processed at the facility.

Approximately 92 to 95% of the waste is plastic, metal and paper materials. Approximately 5% to 8% are liquids with a density of 5 to 7 pounds per cubic foot.

The Facility does not accept for treatment RCRA hazardous materials, radioactive materials, universal wastes or other special wastes from healthcare facilities. Special wastes are solid wastes that require special handling and generally are collected, processed recycled and/or disposed of separately from other wastes. All containers will be screened at the facility for radioactive materials. All customers will be informed of these restrictions.

Waste destined for steam sterilization treatment will be transferred either directly from the transportation vehicle to the sterilizer for treatment, or be stored (as described in 3.c) for the next treatment cycle if the sterilizer is in use. Once treated, the waste will be hauled to Waste Management Eastmont Transfer station (or other approved transfer facility), then compacted and transported to be disposed at the Waste Management Columbia Ridge Landfill & Recycling Center, a permitted solid waste landfill in Arlington, Oregon.

All waste will be processed using steam sterilization in the sterilizer at a minimum temperature of 250°F and 32 psi for 30 minutes.

Verification of waste treatment will be documented from continuous monitoring of the internal temperature and recording pressure of the sterilizer chamber to achieve and maintain the proper treatment temperature of 250°F and 32 psi for 30 minutes or longer, depending on the quantity and compaction of the load.

As a back-up heat-sensitive tape will be used for each load that is processed to indicate that the load has undergone the steam sterilization process. If the load has undergone proper steam sterilization, the indicator tape changes colors.

In addition, routine maintenance will be performed on all critical equipment in accordance with the manufacturers' specifications. Efficiency verification assessments will be performed every 40 hours of operation using the indicator organism *Bacillus stearothermophilis*.

Periodic test verification records will be maintained on site for review by health officials.

All thermometers used in the process will be calibrated annually.

Condensation from the sterilizers will be discharged to the sanitary sewer system.

Any rinse wash from normal cleaning of the sterilizers will be discharged into the sanitary sewer.

Waste material received at the facility not meeting the Waste Acceptance Protocol guidelines will be refrigerated and return to the customer.

b. Sharps Treatment: All sharps received at the facility are steam-treated. Treated sharps not intended to be recycled are disposed of. Accepted sharps intended for recycling may be segregated as a part of a recycling program to recover the plastics that can be recycled but are treated via steam sterilization prior to recycling. If a generator chooses this recycling program the sharps containers are segregated in specific containers marked 'sharps only' and then processed through the Red Bag Solutions unit. For hospital and other healthcare providers who generate "sharps waste" and segregate these wastes from other waste material, WM will manage these materials through a separate process. The segregated "sharps waste" will be processed through a separate system that grinds the waste and utilizes steam pressure and superheated water to treat the waste and render it unrecognizable. At the end of each cycle the ground sharps will be discharged into a container. Full containers will be shipped for recycling or hauled to Waste Management Eastmont Transfer station, then compacted and transported to be disposed at the Waste Management Columbia Ridge Landfill & Recycling Center, a permitted solid waste landfill in Arlington, Oregon.

The sharps processing unit equipment described above utilizes patented technology to treat and grind material with a proprietary cutting system. It is manufactured by Red Bag Solutions. The unit measures approximately 9.5 feet in length by 7.25 feet high by 4 feet wide and weighs approximately 3,500 pounds. An accompanying filter-separator, utilized to de-water the processed solids,

measures 3 feet by 2 feet and weighs an additional 350 pounds. By exposing sharps waste to superheated water and steam (272°F / 133°C) and simultaneously employing a proprietary cutting system, the unit renders infectious medical waste non-infectious, non-hazardous, and non-recognizable. Sharps processed through the unit can be disposed as ordinary solid waste. A temperature and time record is recorded by the unit for each processed batch to document treatment performance. Manufacturer information for the sharps processor unit is contained in Appendix H.

Condensation from the sterilizer-grinder unit will be discharged to the sanitary sewer system.

c. Audit Procedures for Critical Equipment Used to Process/Treat Biomedical Waste and Sharps: Routine maintenance will be performed on all critical equipment in accordance with the manufacturers' specifications. All thermometers used in the process will be calibrated annually. Maintenance documentation will be retained for a period of at least three (3) years in the Facility Operating Records File (FORF), and shall be available to the health officer upon request.

Efficiency verification assessments for treatment used to treat biomedical waste and sharps will be performed every 40 hours of operation using the indicator organism *Bacillus stearothermophilis*. As a back up heat-sensitive tape will be used for each load that is processed to indicate that the load has undergone the steam sterilization process. Audit documentation will be retained for a period of at least three (3) years in the FORF, and shall be available to the health officer upon request.

5. Contingency Plan and Emergency Procedures

In the event of an emergency such as fire, spill, or explosion the operator should contact the following agencies:

- **Public Health Seattle and King County - 206-205-4394**
- **Department of Ecology - 425-649-7000**

In addition to the information in this section, emergency procedures and information is contained in the Facility Emergency Action Plan located in Appendix I.

a. Back-up Facilities: Following is a matrix identifying alternate treatment, transfer and disposal back-up facilities that will be utilized in the event that primary facilities identified below become inoperable, unreachable or unavailable and cannot be used within an appropriate amount of time.

| | | Primary | Back-up for Primary |
|--|---|--|--|
| Treatment | Medical Waste Not Requiring Incinerator Treatment | Seattle BMW Treatment Facility 149 SW Kenyon St. Seattle, WA 98108 Solid Waste Permit: PR0080378 | WM Refuse Inc. Medical Waste 1390 E. Commercial Row Reno, NV 89512 Solid Waste Permit: WM940004 |
| | Medical Waste Requiring Incinerator Treatment | WM Resource Recovery & Recycling Center 7505 State Highway 65 Anahuac, TX 77514 Solid Waste Permit: 2239A | Covanta Marion, Inc. 4850 Brooklake Road, NE Brooks, OR 97305 Solid Waste Permit:#364 |
| Transfer | | WM- Eastmont Transfer Station 7201 W. Marginal Way Seattle, WA 98106 Solid Waste Permit: PR0015734 | King County Bow Lake Transfer Station 18800 Orillia Rd. S Tukwila, WA 98188 Solid Waste Permit: PR0015729 |
| Treated Medical Waste (Solid Waste) Disposal | | WM Columbia Ridge Landfill & Recycling Center 18177 Cedar Springs Lane Arlington, OR 97812 Solid Waste Permit: #1472 | WM Greater Wenatchee Landfill, 191 Webb Road East Wenatchee, WA 98802 Solid Waste Permit: Combined Operating Permit for Municipal Solid Waste Landfilling and Solid Waste Handling Facility Air Operating Permit: 04AQ-C007 |

b. Fire Procedures

- 1) Small fires will be contained with the use of a small fire extinguisher.
- 2) Stop any operating equipment immediately.
- 3) De-energize electricity to the equipment at the main breaker.
- 4) If the fire cannot be control sound the building alarms, evacuate and call 911.
- 5) Consider any damaged containers as untreated and prepare for processing.

c. Spill Response: All spills and/or biological events occurring during transport, processing or treatment will be assessed by internal staff to determine if outside resources are required for cleanup purposes. Trained internal staff will respond to spills of less than 200 gallons. Spills exceeding this threshold will require external response. For these events, WM will contact a certified third-party spill responder to provide necessary cleanup.

In the event of a spill/leak, the vehicle will be decontaminated using an EPA approved disinfectant and the leaking container will be properly labeled and placed in a leak proof over-pack.

A spill kit will be located at interior and exterior storage area sites (Spill kit locations are indicated on Figures 1 and 2; Appendix A). Spill kits will contain the following contents: Granulated absorbent material (e.g., floor-dry), plastic bags, shovel; broom, dust pan, liquid disinfectant and PPE (rubber gloves, face shield, and Tyvek suit (incl. booties).

1. Liquid Spill Procedures

- 1) Immediately cover the spill with an absorbent material.
- 2) Use only a registered EPA anti-bacterial disinfectant for clean up of biomedical liquid spills.
- 3) Wear appropriate personal protective equipment, disposable gloves, gown, eye protection and shoe covers if necessary.
- 4) Clean up materials should be processed in the sterilizer.
- 5) Any clean up wash water will be discharged to the sanitary sewer drain.

2. Dry Spill Procedures

- 1) Wear appropriate personal protective equipment, disposable gloves, gown, eyewear and shoe covers as necessary.
- 2) Immediately repackage the material in appropriate container for processing.
- 3) The old container should be treated immediately.
- 4) Any wash water should be discharged to the sanitary sewer drain.

d. Explosion

- 1) Explosive material is not accepted for treatment.
- 2) Any explosion will be treated as an emergency, notify 911 and sound the building alarm.
- 3) Electrical service should be de-energized.

e. Equipment Failure

- 1) If there is an equipment failure, material in the sterilizer will remain and the steam cycle will be repeated. If the steam cycle cannot be repeated the material will be removed from the sterilizer and repackaged as biomedical waste for transport to a back up facility.
- 2) Any wash water used will be discharged to the sanitary sewer drain.

f. Spill Containment Equipment

- 1) Commercial biomedical waste spill kits containing approved personal protective equipment, liquid absorbent, and disinfectant.
- 2) Only EPA approved anti-microbial disinfectants maybe used to clean up spills.
- 3) Grease and other lubricants will be cleaned with dry clean.
- 4) Wash water will be discharged to the sanitary sewer.

6. Supervision and Staffing

- 1) Supervision of the biomedical waste operation will be under personnel trained in the operation of the facility.
- 2) Number of staff will be dependent on the operation. However, there will be at least one supervisor and a plant worker on site during any operating times. Following is a list of key personnel and their areas of responsibility:

| Title | Responsibility | Phone Number |
|-----------------------|---|--------------|
| Administrator | Coordination of facility activities, BMP implementation, training, monitoring, facility inspection, and reporting | 206.406.3030 |
| Plant Manager | Coordinates Facility operations; schedules work activities; Provides training/education to workers/customers on Facility biomedical waste operations and acceptance requirements; Interfaces with Customers on operational issues that arise from improper packaging, improper materials etc. | TBD |
| Plant Lead | Operates treatment equipment at Facility; directs Plant Worker job duties | TBD |
| Plant Worker | Performs maintenance, storage and disposal of maintenance supplies, spill prevention and response, and program support; Operates treatment equipment at Facility. | TBD |
| Driver | Collects and hauls untreated biomedical waste to Facility; hauls treated biomedical waste to transfer station. | TBD |
| Environmental Manager | Provides support to the Facility operations for regulatory compliance matters; Leads permitting activities and coordinates regulatory reporting activities. | 360.801.5239 |

3) All Facility employees are required to participate in a new employee medical surveillance program. All employees will have annual medical surveillance evaluations.

7. Training Program

Training will be administered in accordance with the site specific Training Matrix (See Appendix E). Each employee involved in the operations at the facility will be required to undergo a minimum of 32 hours of training. Training will be administered initially and annually thereafter as required by the applicable local, state, and federal regulations as well as internal corporate requirements. Driver certification is required and will be maintained in accordance with DOT regulations. Training records will be maintained at the facility for three years.

Biomedical Waste Treatment Operations personnel receive comprehensive training covering safety and this Operation Plan. Training is mandatory for new employees before starting duties, then annually thereafter for Blood-Borne Pathogen and PPE. DOT training is done once every two years. Training topics covered include: Blood-borne Pathogens/Facility Exposure Control Plan, Hazard Communication, Waste Acceptance, DOT requirements, Emergency Management and Housekeeping Practices.

All personnel on site will be trained. Training includes processing and mechanical operations, emergency preparedness, safety training and OSHA compliance, injury prevention, personal protective equipment, bloodborne pathogens.

All employees will have annual refresher training and annual medical surveillance evaluations.

At a minimum there will be monthly safety meetings for all staff.

8. Recordkeeping:

All record will be maintained on site for a minimum of three years unless otherwise required by law.

This Biomedical waste management plan will be reviewed annually and is available for inspection at the request of the health officer.

Exhibit 10

MEDICAL WASTE DISPOSAL AGREEMENT

THIS AGREEMENT dated this 8th day of September, 2010 by and between Marion County, a political subdivision of the State of Oregon, hereinafter called County, and ~~WASTE MGMT OF OREGON INC.~~ ^{WASTE MGMT OF WASHINGTON INC.} hereinafter called Hauler, provides for disposal of Medical Waste at the Marion County Solid Waste-to-Energy Facility located in Brooks, Oregon, hereinafter called WTEF.

The parties agree as follows:

1. **Definition of Medical Waste:** For purposes of this Agreement, Medical Waste shall be defined as the waste generally produced by hospitals, health-care facilities, doctor, and dentist offices in the course of delivering patient care.
2. **Excluded Waste:** Specifically excluded from the definition of Medical Waste are the following:
 - a. RCRA-designated wastes
 - b. Radioactive wastes
 - c. Anatomical parts that do not emanate from:
 - i. surgery
 - ii. obstetrical procedures
 - iii. autopsy
 - iv. laboratory procedures
 - d. Large animal carcasses over 65 pounds.
 - e. Wastes that are not permitted for acceptance by the Oregon Department of Environmental Quality.
3. **Right to deliver Medical Waste to the WTEF:** Subject to the terms and conditions set forth in this Agreement, the County hereby grants the Hauler the non-exclusive right to deliver Medical Waste to the WTEF at a rate to be determined from time to time by the County.
4. **Delivery of Medical Waste:** The Hauler agrees that the Medical Waste will be delivered to the waste-to-energy facility in vehicles which comply with state and federal laws and regulations and the requirements of the County, including, but not limited to, the following: Delivery vehicles will not compact the Medical Waste and will be leak-proof; all waste shall be contained in impervious, plastic-lined boxes or, in the case of sharps, in boxes specifically designed for sharps; and each box shall bear the universal biological hazard symbol.

5. **Billing by County:** Incoming vehicles will be weighed on the scale at the WTEF, and the vehicle's tare weight as determined by the County will be subtracted from the scale reading to determine the weight of Medical Waste delivered to the WTEF. The County shall use this weight to calculate the billing charges for disposal. The County will bill the Hauler by the 10th of the following month. The Hauler shall pay the County within 30 days of the billing date. If payment is not received in a timely manner, the County will charge the Hauler a penalty fee of 1.25 percent of the billing, which is 15.00 percent annually. If the billing and fee are not paid within 30 days of the assessment of penalty this agreement is automatically terminated.

6. **Acceptance of Medical Waste:** A copy of the vehicle's manifest shall be presented to the County at the scales. This document shall specify the source(s) of the Medical Waste and the general contents of the vehicle. The County shall have the sole discretion to reject any vehicle, or any portion of the delivered Medical Waste, if, in the County's opinion, the waste is either not Medical Waste as defined herein, or poses an unacceptable risk to the WTEF or its personnel. In such instance, the Hauler shall immediately remove the Waste from the WTEF at the Hauler's cost and expense. Any contamination caused by such Waste by the Hauler to the WTEF shall be eliminated at the Hauler's cost and expense.

Medical Waste shall be deemed accepted by the County after it has been off-loaded by the Hauler's personnel, and after the County has reviewed the associated manifest and inspected the general condition of the shipping containers to ascertain that none is damaged or leaking.

7. **Incineration of Medical Waste:** The County will, to the best of its ability, cause through its agreement with the operator of the WTEF, to incinerate all acceptable medical waste delivered by the Hauler. If for some unforeseen circumstance the WTEF does not incinerate Medical Waste delivered by the Hauler, the County shall notify the Hauler.

8. **Delivery times:** Delivery times will be made by the County in conjunction with the operator of the WTEF. If the Hauler has not scheduled a time with the County, the Hauler's Medical Waste may be rejected by the County.

9. **Unloading of Medical Waste:** The Hauler shall be responsible for scheduling a time with the County for delivery of Medical Waste to the WTEF. The Hauler, upon arriving at the WTEF, shall use his personnel to off-load the boxed medical waste onto the conveyor at the WTEF.

10. **Consideration:** In consideration for the County agreeing to accept delivery of and to incinerate the Medical Waste delivered by the Hauler, the Hauler agrees to pay the County the current rate (inclusive of the weight of any containers) as determined at the WTEF scale.

11. **Term and Termination:** The term of this Agreement shall commence on the date of this Agreement and continue thereafter until terminated by either party. Either party may terminate this Agreement upon 30 days' written notice given in accordance with the provisions of this Agreement.

12. **Governmental Regulations:** The Hauler shall be responsible for, and agrees to comply with, all applicable local, state, and federal regulations which govern collection and transportation of solid waste inclusive of medical or infectious waste. The Hauler shall also obtain all necessary permits required in connection with collection and transportation of medical waste.

13. **Indemnification:** The Hauler hereby agrees to indemnify and hold the County and the WTEF operator harmless from any and all liability or damages resulting or arising from a failure by the Hauler to comply with its obligations under the Agreement, including the payment of attorneys' fees and costs incurred as a result of such failure. The Hauler agrees to indemnify and hold the County and the WTEF Operator harmless against any claims brought against the County or the Operator by Hauler's employees, agents, or representatives. The County hereby agrees to indemnify and hold the Hauler harmless from any and all liability or damages resulting or arising from a failure by the County to comply with its obligations under the Agreement, including the payment of attorneys' fees and costs incurred as a result of such failure.

14. **Insurance:** The Hauler shall obtain and maintain \$500,000 per each occurrence combined single limit for personal injury and property damage, for comprehensive general liability, and for auto liability insurance, or greater amount, as may be required by the County. Such insurance shall be evidenced by a Certificate of Insurance provided to the County, indicating coverage, limits, and effective dates, by an insurance company licensed to do business in the State of Oregon. Also, an endorsement shall be issued by the company showing the County as additional insured and provide that such policy shall not be cancelled, terminated, amended, or permitted to lapse except upon not less than thirty (30) days prior written notice to that effect to the County.

15. **Assignments:** Neither party hereto shall assign its rights or delegate its duties under this Agreement or any part hereof without the prior written consent of the other party. Subject to the foregoing, this Agreement shall be binding upon the parties' respective successors and assigns.

16. **Notices:** Any notice given pursuant to this Agreement shall be in writing and deemed given when received or delivered personally, or within three days, if deposited in the U.S. mail, certified or registered mail, return receipt requested, with postage prepaid, at the address set forth below the signature of such party hereto, or at such other address as such party may designate by written communication to the other party in accordance with this Agreement.

IN WITNESS THEREOF, the parties hereto have executed this Agreement on the 8th day of DECEMBER, 2010.

WASTE MANAGEMENT OF WASHINGTON INC.
WASTE MANAGEMENT OF OREGON INC.
Hauler

Marion County

By:  _____

By:  _____

Title: DEAN KATTLER, AREA VP

Title: ENVIR. SERVICES DIVISION MANAGER

Address:

Address:

13225 NE 126th PLACE

Marion County

KIRKLAND, WA 98034

Department of Public Works

5155 Silverton Rd. NE

Salem, OR 97305-3802

Phone: (425) 814-7831

503-588-5169

Fax: (866) 674-1183

503.588.7970

typing/nits/cont/medical waste disposal agreement 13NOV03.word

Exhibit 11

SCHEDULE A-22

LESSOR: Commercial Trailer Leasing, Inc.

LEASE #: WM-001

LESSEE: Waste Management of Washington, Inc.

DATE OF CONTRACT: February 11, 2011

This Schedule A is incorporated as part of the Lease. The Vehicle(s) below are leased under the terms and conditions of the Lease

| VEHICLE # | VEHICLE DESCRIPTION | SERIAL NUMBER | DELIVERY DATE | PLACE OF DELIVERY | TERM OF LEASE | MONTHLY RENTAL |
|-----------|--|---------------|---------------------|-------------------|---------------|--|
| | Quantity: Five (5) Year: 2011 Model: | TBD | Projected 5/2011 | See below | 108 Months | Redacted per mo./trailer Redacted per mile per diesel hour |
| | Color: White Make: Great Dane Body Style: Refrigeration | | | | | |
| | Lease commences upon delivery date Mileage and diesel hour charges to increase each year as per CPI Customer is allowed unlimited mileage Capitalized cost of equipment - Redacted per trailer Monthly depreciation credit - Redacted per trailer Guaranteed purchase option - Redacted per trailer | | | | | |

VEHICLE SPECIFICATIONS

***Domicile Location - Seattle, WA
53'x102"x13'8"
Air ride suspension with manually operated dump valve
Side posts, set every 24 inches with 12" from front to support gear
Overhead door with 5 hinges per panel and door track protector
12" crossmember spacing
Extra gauge aluminum roof
Hubodometer
Extra gauge aluminum side panels
No side corrugations
Heavy duty landing gear assembly
1.375" heavy duty aluminum flat floor with safety grip surface and drains in front and rear
***Side skirt aerodynamic devices
**Low rolling resistance tires
Extra crossmembers at rear
Fiberglass interior lining
16" high aluminum scuffliner on sides with reinforcement behind scuffliner
Kendall EBL lubrication
Heavy duty mainbeam and approach plate
3 rows of recessed E track located at 24", 48" and 72" from floor to centerline
2 domeights evenly spaced along interior with switch located at the rear
Unit numbers and height decals
LED long life lighting system
Carrier: Ultra XL with electric standby refrigeration unit
230v 3ph electric standby with phase reversal
05G 40 CID compressor
CT4 134DI direct injection engine
Low noise package
Remote light bar
Low fuel shutdown switch
Return air bulkhead
Microprocessor control system
65 amp alternator
100 gallon fuel tank
Installation of Waste Management decal package
Delivery to Seattle, WA

This Lease and any Vehicle(s) leased hereunder shall be subject to any rights and interests in and to said Vehicle(s) under any respective agreement or agreements that any assignee or other secured party may hold on same.

Lessee understands that this agreement is a lease only; Lessee shall have no ownership rights in the Vehicle(s), except for possession and use pursuant to the terms and conditions of the Lease.

Dated: February 11, 2011

Commercial Trailer Leasing, Inc.

Waste Management of Washington, Inc.

Name of Lessor

Name of Lessee

By:  2/22/11

By:  D. KATLER, AUP

February 11, 2011

**ADDENDUM TO LEASE AGREEMENT #WM-001
MAINTENANCE RIDER**

Lessee shall be charged ^{Redacted} per mile and ^{Redacted} per diesel hour per trailer as a maintenance cost. The mileage charge and refrigeration unit hourly charge will both increase annually according to the Consumer Price Index (CPI). Lessor shall be responsible for performing on-site maintenance and repairs in Seattle, WA on the equipment (identified as five (5) 53 foot refrigerated trailers with air ride suspension) during the 108 month lease term including, but not limited to, the replacement of tires, refrigeration unit, landing gear, brakes, lights, etc. rendered unusable through normal wear. Not included in the maintenance charge are any damages, flat tires and theft of components, except when in the sole care and custody of the Lessor. In the event that Lessee's trailer must be taken out of service for a period exceeding forty-eight (48) hours to perform normal and scheduled maintenance (excluding weekends), Lessor shall provide a standard refrigerated substitute/replacement trailer. Normal and scheduled maintenance shall be mutually agreed upon by both parties.

Any repairs/service which are performed by Lessor, which are outside the parameters of normal wear under the maintenance agreement, will be billed to Lessee at Lessor's current labor rate of \$55.00 per hour. Any repairs/service which are performed by Lessor's subcontractors or vendors, which are outside the parameters of normal wear under the maintenance agreement, will be billed to Lessee at actual cost plus fifteen (15) percent. Lessor will provide substantiation of its cost upon request by Lessee. Lessor acknowledges Carrier as a qualified vendor and will directly accept billing for repairs performed by Carrier on its behalf. Carrier must make a reasonable effort to obtain prior authorization from Lessor for said repairs.

Upon expiration of this lease, Lessee shall return each item of equipment, at lessee's expense, to a mutually agreed upon location, normal wear excepted. If Lessee fails to return any item of equipment at the end of the original lease term or any renewal, then this lease shall be deemed extended on a month-to-month basis with rent payable on the first of each month, at the previous rate. All repairs and costs which fall outside the scope of normal wear shall be mutually agreed upon. Repairs, parts, supplies, accessories, equipment or devices furnished or affixed to any equipment pursuant to this paragraph shall become the property of the Lessor, except for any thereof which are not replacements and are furnished by Lessee and which may be removed without in anyway impairing or affecting the functioning or use of any such equipment. The interior of each trailer must be sanitized and cleaned and all decals must be removed from the trailer at Lessee's expense.

Lessee shall have the option to purchase any and all of the above equipment upon lease expiration at a price of Redacted per trailer, provided that all prior monthly lease payments and any other charges have been timely paid. If Lessee does not exercise the purchase option on any or all of the above equipment, then Lessor, at its option, may sell any or all of the above equipment to a third party. Any deficiency between the net sales proceeds and the purchase option price of Redacted per trailer shall be promptly paid by Lessee to Lessor. In the event that the net sales proceeds exceed the purchase option price of Redacted per trailer, then Lessor shall promptly pay to Lessee the excess.

Sincerely,

Commercial Trailer Leasing, Inc.

David Eisen
Chief Executive Officer

2/22/11

Accepted By:

Waste Management of Washington, Inc.

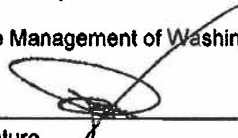
Signature

DEAN KATTLER, AREA VP
Print Name & Title

FEBRUARY 18th, 2011
Date

VEHICLE LEASE SERVICE AGREEMENT - SCHEDULE A

Customer : Waste Management of Washington, Inc.



| Scha No. | Qty. | Year | VEHICLE DESCRIPTION | | VEHICLES WILL BE | | Lease Term Month | Original Agreed Value | Depreciation Credit Per Month | Fixed Lease Charge | Mileage Charge | | | | |
|----------|-------|-----------------------------|---------------------|---------------------------|-------------------------|---------------------------|------------------|-----------------------|-------------------------------|-----------------------|----------------|--------------------|-------------------------|---|----------------------|
| | | | Make | Model Type | Domiciled At | Serviced At | | | | | | | | | |
| 10-01 | 1 | 2011 | INTERNATIONAL | DURASTAR - 25999 GVW SADC | TACOMA, WA | TACOMA, WA | 60 | | | | | | | | |
| | | | | | | | | | | | Redacted | | | | |
| Scha No. | 10-01 | Refrigeration Charge Per Hr | | Est. Annual Mileage | Est. Annual Reefr Hours | Mfr's Rec'd Max GVW / GCW | Licensed Weight | Tax Notes | License Type B = Base I = IRP | Estimated Annual Cost | | Fuel Tax Reporting | Penske To Provide Fuel? | Initial Painting & Lettering Allowance/ Vehicle | Penske Provider Sub. |
| | | Running | Standby | | | | | | | License | HVUT | | | | |
| | | \$ 0.00 | \$ 0.00 | 40,000 | N/A | 25,999/25,999 | 25,999 | | B | P \$175 | N/A | 0 | N | \$ 0 | Y |

The Schedules Noted Supersede

| Scha No. | Sch A Vehicle No(s) (Indicate "All" if Appropriate) |
|----------|---|
| 10-01 | WA |

States/Provinces of Travel

Notes : There will be no CPI increase for the duration of this lease term.

To the extent any vehicle on this schedule requires Diesel Exhaust Fluid (DEF), Penske may provide Customer with DEF at Penske's rates then in effect, including any applicable taxes and fees, and the charge for DEF will appear on Customer's fuel invoice or otherwise be billed weekly Customer agrees to pay for initial fueling upon in-service. Customer may return the vehicle(s) empty at end of term.

Abbreviation Key: P = PTL Responsibility C = Customer Responsibility Y = Yes N = No S = Separate Invoice Requested by Customer E = Customer Exempt N/A = Not Applicable

PENSKE TRUCK LEASING CO., L.P.
By: [Signature] Title: [Signature]
Customer: Waste Management of Washington, Inc.
Date: 08/10

| Penske Truck Leasing Service Location - Street Address | | City, State and Zip Code | |
|---|----------------------|--------------------------|---------------------|
| TACOMA, WA | | | |
| MAKE | INTERNATIONAL | BBC | 111 INCHES |
| MODEL | DURASTAR - 25999 GVW | GVW | 25999 LBS |
| YEAR | 2011 | WEIGHT | 10204 LBS + or - 3% |
| TYPE | SADC | | |
| <p>ENGINE</p> <ul style="list-style-type: none"> - MAXXFORCE DT (EPA 10) - 230 HP @ 2200 RPM - 620 lb/ft TORQUE @ 1300 RPM <p>POWER TRAIN</p> <ul style="list-style-type: none"> - TRANSMISSION - ALLISON AUTOMATIC 2100 RDS P - CLOSE RATIO 6 SPEED WITH DOUBLE OVERDRIVE - WITH PTO PROVISION - LESS RETARDER - T-BAR TYPE TRANSMISSION SHIFT CONTROL - (2000 SERIES) - REAR AXLE - 17,500 lb CAPACITY - SINGLE REDUCTION WITH 190 WHEEL ENDS (17080S) - 5.57 REAR AXLE RATIO - 70 MPH - REAR SUSPENSION - 18,500 lb CAPACITY - WITH 4,500 lb AUXILIARY RUBBER SPRING VARI-RATE - TRANSMISSION OIL PAN MAGNET IN OIL PAN - TRANSMISSION OIL FILTER - MOUNT ON TRANSMISSION - TRANSMISSION OIL - SYNTHETIC - (ALLISON 2000 SERIES) - SHIFT CONTROL PARAMETERS - ALLISON PERFORMANCE PROGRAMMING IN PRIMARY AND ALLISON ECONOMY PROGRAMMING IN SECONDARY - ESOC FITTING - 7/16" PUSH TYPE EXTRACTOR FITTING - REAR AXLE DRAIN PLUG - (1) MAGNETIC - REAR AXLE LUBE - FUEL EFFICIENT - SYNTHETIC - 75W-90 - 1-29.99 PINTS - WHEEL SEALS, REAR - OIL LUBRICATED, INCLUDES WHEEL BEARINGS <p>ENGINE EQUIPMENT</p> <ul style="list-style-type: none"> - EXHAUST SYSTEM - HORIZONTAL TAIL PIPE - SINGLE, HORIZONTAL, AFTERTREATMENT DEVICE FRAME MOUNTED RIGHT SIDE BACK OF CAB - BATTERIES - (3) - GROUP 31, 12 VOLT, 2775 CCA, ABSORBED GLASS MAT (AGM) - RADIATOR - ALUMINUM - 817 Sq. In. LOUVERED, 2 ROW, CROSS FLOW, OVER UNDER SYSTEM, WITH 262 Sq. In. CHARGE AIR COOLER - INCLUDES IN-TANK TRANSMISSION OIL COOLER - ALTERNATOR - 165 AMP - 36SI, 12 VOLT, PAD MOUNTED, BRUSHLESS WITH REMOTE VOLTAGE SENSOR - STARTING MOTOR - MT-38 - 12-VOLT, LESS THERMAL OVER-CRANK PROTECTION - AIR CLEANER - INCLUDES SERVICE PROTECTION ELEMENT - AIR CLEANER RESTRICTION GAUGE - AIR CLEANER MOUNTED - AIR COMPRESSOR - 13.2 CFM (TU-FLO 550) - ANTIFREEZE - LONG LIFE COOLANT, -40F - AUTOMATIC ENGINE SHUT/DOWN - WITH 30 SECOND DELAY, WITH INTERNATIONAL ENGINES - BLUE STRIPE COOLANT HOSES - CLUTCH - OMIT ITEM (CLUTCH & CONTROL) - COLD STARTING EQUIPMENT - INTAKE MANIFOLD ELECTRIC GRID HEATER WITH ENGINE ECM CONTROL - DEAERATION SYSTEM WITH SURGE TANK <p>FRAME / WHEEL BASE</p> <ul style="list-style-type: none"> - 254" WHEELBASE FOR 24 FOOT BODY (187 INCH CA) - FRONT BUMPER - FULL WIDTH, AERODYNAMIC, CHROME PLATED STEEL, 0.142" MATERIAL THICKNESS - GVWR SPECIAL RATING - LIMITED TO 25,999 lb GVWR - FRAME RAILS - HIGH STRENGTH, LOW ALLOY STEEL, 80,000 PSI YIELD, 10.250" X 3.092" X 0.375", 427" MAXIMUM OAL - FRAME COLOR - BLACK - FRONT BUMPER EXTENSION - 4" - HUCK FASTENERS ARE USED TO ATTACH CROSSMEMBERS TO FRAME RAILS - LICENSE PLATE HOLDER - INCLUDES UPPER & LOWER MOUNTING PLATE HARDWARE, MOUNTING IN EXISTING HOLES IN FRONT BUMPER - REAR CROSSMEMBER - 106" AFTERFRAME <p>FRONT AXLE & SUSPENSION</p> <ul style="list-style-type: none"> - FRONT AXLE - 10,000 lb CAPACITY - I-BEAM TYPE (I-100SG) - FRONT SUSPENSION - 10,000 lb CAPACITY, PARABOLIC, TAPER LEAF SPRING, WITH SHOCK ABSORBERS - FRONT SPRING PINS - MAINTENANCE FREE WITH RUBBER BUSHINGS - FRONT WHEEL SEALS - OIL LUBRICATED WHEEL BEARINGS - STEERING GEAR - POWER (TAS-66) <p>BRAKES</p> <ul style="list-style-type: none"> - AIR BRAKE SYSTEM - DUAL SYSTEM FOR STRAIGHT TRUCK APPLICATIONS - AIR BRAKE ABS - FULL VEHICLE WHEEL CONTROL SYSTEM (4-CHANNEL) - AIR COMPRESSOR AIR SUPPLY LINE - THROUGH AIR CLEANER - FRONT BRAKES - AIR, S-CAM, 15" X 4", INCLUDES 20 Sq. In. LONG STROKE BRAKE CHAMBERS - REAR BRAKES - AIR, S-CAM, 16.5" X 7", INCLUDES 30/30 Sq. In. SPRING ACTUATED PARKING BRAKE CHAMBERS - FRONT AXLE BRAKE CHAMBERS - 20 Sq. In. <p>ELECTRONIC ROAD SPEED GOVERNOR</p> <ul style="list-style-type: none"> - EMISSION COMPLIANCE - FEDERAL, DOES NOT COMPLY WITH CALIFORNIA CLEAN AIR REGULATIONS - ENGINE FAN DRIVE - VISCOUS SCREW ON TYPE (SABS) - INCLUDES NYLON FAN - OPTIMIZED POSITION - ENGINE BLOCK HEATER - 120 VOLT - 1250 WATT - WITH RECEPTACLE MOUNTED UNDER LEFT DOOR - ENGINE OIL FILTER - SPIN ON TYPE - ENGINE OIL DRAIN PLUG - (1) MAGNETIC - INDICATOR, LOW COOLANT LEVEL - WITH AUDIBLE ALARM - POWER GRIP SHRINK BAND HOSE CLAMPS ON ALL POSSIBLE COOLANT CONNECTIONS - 2010 EMISSION ESCALATOR (MAXXFORCE DT) - BATTERY DISCONNECT SWITCH - MOUNTED ON BATTERY BOX, POSITIVE TYPE, LOCKING, KEY OPERATED (51-316) | | | |
| <p>THIS COPYRIGHT-PROTECTED WORK MAY NOT BE COPIED, REPRODUCED OR DISTRIBUTED WITHOUT WRITTEN CONSENT OF PENSKE TRUCK LEASING CO., L.P. ANY UNAUTHORIZED USE IS EXPRESSLY PROHIBITED AND SHALL BE CONSIDERED COPYRIGHT INFRINGEMENT</p> | | | |

| Penske Truck Leasing Service Location - Street Address | | City, State and Zip Code | |
|---|----------------------|--------------------------|---------------------|
| TACOMA, WA | | | |
| MAKE | INTERNATIONAL | BBC | 111 INCHES |
| MODEL | DURASTAR - 26999 GVW | GVW | 25999 LBS |
| YEAR | 2011 | WEIGHT | 10204 LBS + or - 3% |
| TYPE | SADC | | |
| <ul style="list-style-type: none"> - REAR AXLE BRAKE CHAMBERS - 30/30 Sq. In. - AUTOMATIC SLACK ADJUSTERS - FRONT BRAKES - AUTOMATIC SLACK ADJUSTERS - REAR BRAKES - FRONT BRAKE DUST SHIELDS - REAR BRAKE DUST SHIELDS - AIR DRYER - AD-IP, WITH HEATER - PARKING BRAKE VALVE - YELLOW KNOB LOCATED ON INSTRUMENT PANEL - COLOR CODED NYLON BRAKE LINES - TWIST TYPE DRAIN VALVE - SPRING BRAKE MODULATOR VALVE | | | |
| <p>TIRES & WHEELS</p> <ul style="list-style-type: none"> - FRONT WHEELS - 22.5 X 8.25 POLISHED ALUMINUM DISC - 10 HOLE HUB PILOT WITH STEEL HUBS - REAR WHEELS - 22.5 X 8.25 POLISHED ALUMINUM DISC - 10 HOLE HUB PILOT WITH STEEL HUBS - FRONT TIRES - G662 RSA FUEL MAX - 11R22.5 X 14 PR - REAR TIRES - G162 - 11R22.5 X 14 PR - OMIT TIRE WHEEL BALANCING - FRONT AND REAR - TIRE VALVE STEM CAPS - V2B FLO-THRU DESIGN | | | |
| <p>FUEL TANKS</p> <ul style="list-style-type: none"> - ANTI-SIPHON DEVICE - SNAP IN TYPE - FOR DUAL TANKS - FUEL WATER SEPARATOR - 243 HEATED - FUEL TANKS - (2) - 50 GALLON/189 LITER, NON-POLISHED ALUMINUM, 16 INCH DEPTH, TOP DRAW, MOUNTED LEFT SIDE (ROAD SIDE) AND RIGHT SIDE (CURB SIDE) - UNDER CAB - FUEL LINES - NYLON TUBING WITH O-RING, SNAP-ON, QUICK-CONNECT FITTINGS AT BOTH ENDS - FUEL SURCHARGE | | | |
| <p>CAB</p> <ul style="list-style-type: none"> - CAB INTERIOR TRIM - DELUXE - CAB EXTERIOR PAINT - STANDARD COLORS (Colors can be selected using the Colors & Parameters tab) - MIRRORS - BRIGHT FINISH ARMS WITH BRIGHT FINISH HEADS - (2) RECTANGULAR 7.09" X 15.75" - HEATED - BREAKAWAY TYPE WITH INTEGRAL CONVEX BOTH SIDES - 102" INSIDE SPACING - HOOD MOUNTED MIRRORS - BRIGHT STYLE CONVEX - (2) - LEFT SIDE AND RIGHT SIDE - HOOD MOUNTED 7.44 SQUARE INCHES - STEERING COLUMN - TILTING AND TELESCOPING - STEERING WHEEL - 18" DIAMETER - 2-SPOKE - BLACK - DRIVER SEAT - AIR SUSPENSION - VINYL - HIGH BACK WITH INTEGRAL HEADREST ISOLATED WITH 2 POSITION FRONT CUSHION ADJUSTMENT - 3 TO +14 DEGREE SEAT BACK ADJUSTMENT - AIR LUMBAR SUPPORT - PASSENGER SEAT - VINYL - TWO PERSON - INTEGRATED HEADRESTS IN BOTH OCCUPANT'S POSITIONS, WITH UNDER SEAT STORAGE COMPARTMENT - RADIO - AM/FM STEREO WITH CD PLAYER, WEATHERBAND, CLOCK, | | | |
| <ul style="list-style-type: none"> INCLUDES MULTIPLE COAXIAL SPEAKERS, SATELLITE RADIO COMPATIBLE - "A" PILLAR COVER - MOLDED PLASTIC - ADDITIONAL KEYS - 2 ADDITIONAL KEYS - AIR CONDITIONING - BLEND-AIR WITH INTEGRAL HEATER AND DEFROSTER - AIR HORN - BLACK, SINGLE TRUMPET, AIR SOLENOID OPERATED, MOUNTED BEHIND BUMPER ON RIGHT FRAME RAIL - ARM REST - (2) MOLDED PLASTIC - (1) FOR EACH DOOR - BUG SCREEN - MOUNTED BEHIND GRILLE - CAB - CONVENTIONAL - 82 INCHES OUTSIDE WIDTH - STEEL - CAB EXTERIOR PAINT - BASE COAT/CLEAR COAT - CAB EXTERIOR PAINT - SINGLE COLOR - CAB INTERIOR GRAB HANDLE - (1) "A" PILLAR MOUNTED, PASSENGER SIDE - CAB INTERIOR GRAB HANDLE - (2) "B" PILLAR MOUNTED, ONE EACH SIDE - CAB INTERIOR TRIM PANELS - CLOTH COVERED MOLDED PLASTIC, FULL HEIGHT, ALL EXPOSED INTERIOR SHEET METAL IS COVERED EXCEPT FOR THE FOLLOWING; TWO-MAN PASSENGER SEAT - BACK PANEL IS ONLY PARTIALLY COVERED; FULL BENCH SEAT - BACK PANEL IS VOID OF COVERING - CIGAR LIGHTER - INCLUDES ASH CUP - CIRCUIT BREAKERS - MANUAL RESET - MAIN PANEL - SAE TYPE III - WITH TRIP INDICATORS - REPLACES ALL FUSES EXCEPT FOR 5 AMF FUSES - COAT HOOK - LOCATED ON REAR WALL, CENTERED ABOVE REAR WINDOW - DATA LINK CONNECTOR - IN CAB FOR VEHICLE PROGRAMMING AND DIAGNOSTICS - DOOR STORAGE POCKET - (1) DRIVER DOOR, MOLDED PLASTIC, FULL LENGTH - DOOR STORAGE POCKET - (1) PASSENGER DOOR MOLDED PLASTIC - FULL LENGTH - DOOR TRIM PANELS - MOLDED PLASTIC - DRIVER AND PASSENGER DOOR - DVIR CLIP ON SUN VISOR - ELECTRIC STARTER SWITCH - KEY OPERATED - ELECTRICAL FUSES - SAE BLADE TYPE - ELECTRICAL SYSTEM - 12-VOLT, STANDARD EQUIPMENT - ELECTRONIC CRUISE CONTROL - CONTROLS INTEGRAL TO STEERING WHEEL - FLOOR COVERING - BLACK RUBBER - FRESH AIR FILTER - FOR USE IN HVAC - FUEL FILTER WARNING LIGHT - OMIT - GAUGE - TRANSMISSION OIL TEMPERATURE FOR ALLISON TRANSMISSIONS - GAUGES - ENGLISH WITH ENGLISH ELECTRONIC SPEEDOMETER - MPH, TACHOMETER, VOLT METER, OIL PRESSURE, WATER TEMPERATURE, FUEL LEVEL, HOUR METER, FAULT CODE DISPLAY | | | |
| <p>THIS COPYRIGHT-PROTECTED WORK MAY NOT BE COPIED, REPRODUCED OR DISTRIBUTED WITHOUT WRITTEN CONSENT OF PENSKE TRUCK LEASING CO., L.P. ANY UNAUTHORIZED USE IS EXPRESSLY PROHIBITED AND SHALL BE CONSIDERED COPYRIGHT INFRINGEMENT</p> | | | |

| | | | |
|--|----------------------|---|---------------------|
| Penske Truck Leasing Service Location - Street Address | | City, State and Zip Code | |
| TACOMA, WA | | | |
| MAKE | INTERNATIONAL | BBC | 111 INCHES |
| MODEL | DURASTAR - 25999 GVW | GVW | 25999 LBS |
| YEAR | 2011 | WEIGHT | 10204 LBS + or - 3% |
| TYPE | SADC | | |
| <p>WARNING SYSTEM, VISUAL & AUDIBLE</p> <ul style="list-style-type: none"> - GLASS - ALL WINDOWS TINTED - GRILLE - CHROME - HAND THROTTLE CONTROL - ENGINE SPEED CONTROL, ELECTRONIC, STATIONARY, VARIABLE SPEED, MOUNTED ON STEERING WHEEL - HYDROFLUOROCARBON HFC-134A REFRIGERANT - INSTRUMENT PANEL - FLAT PANEL CENTER SECTION - INSTRUMENT TRIM PANEL - MOLDED PLASTIC WITH BLACK CENTER SECTION, HIDDEN CUP HOLDER AND ASH TRAY (PULL-OUT) - IP CLUSTER DISPLAY - ON BOARD DIAGNOSTICS DISPLAY OF FAULT CODES IN GAUGE CLUSTER - OVERHEAD CONSOLE - MOLDED PLASTIC WITH DUAL STORAGE POCKETS, RETAINER NETS AND CB RADIO POCKET - SINGLE ELECTRIC HORN - DRIVER SEAT BELT - 3 POINT LAP AND SHOULDER BELT - TWO PERSON PASSENGER SEAT BELT - (2) ONE 3 POINT SHOULDER BELT AND ONE 2 POINT LAP BELT (CENTER POSITION) - STEP - (4) TWO STEPS PER DOOR - SUN VISOR - INTERIOR - (2) - PADDED VINYL INTEGRAL TO CONSOLE. DRIVERS SIDE HAS TOLL TICKET STRAP - TILTING FIBERGLASS HOOD - THREE PIECE CONSTRUCTION - TURN SIGNAL SWITCH - SELF CANCELLING - WINDSHIELD WIPER SPEED CONTROL - FORCE WIPERS TO SLOWEST INTERMITTENT SPEED WHEN PARK BRAKE SET AND WIPERS LEFT ON FOR A PREDETERMINED TIME - WINDSHIELD WIPER SWITCH - 2 SPEED WITH WASH AND INTERMITTENT FEATURE, INTEGRAL WITH TURN SIGNAL LEVER - WINDSHIELD WIPERS - COWL MOUNTED SINGLE ELECTRIC MOTOR - DRIVER SEAT ARM REST - RIGHT - KEYS - ** ONLY SELECT IF ORDERING MULTIPLE UNITS ** - INCLUDES IGNITION AND CAB DOOR KEYS - POWER WINDOWS AND DOOR LOCKS - LEFT AND RIGHT DOORS - INCLUDES EXPRESS DOWN FEATURE - POWER SOURCE - CIGAR TYPE RECEPTACLE WITHOUT PLUG AND CORD - * Custom weight decals & Cab decals | | <p>CENTER MOUNTED</p> <ul style="list-style-type: none"> - CHASSIS WIRING - COLOR CODED AND CONTINUOUSLY NUMBERED - FOG LIGHTS - (2) CLEAR OVAL WITH H3/55W/ HALOGEN BULBS - FRONT TURN SIGNALS - FLUSH MOUNTED, INCLUDES REFLECTORS AND AUXILIARY SIDE TURN SIGNALS - LIGHTS - (5) AMBER L.E.D. CLEARANCE/MARKER, FLUSH MOUNTED ON CAB OR SUNSHADE - TEST EXTERIOR LIGHTS - PRE-TRIP INSPECTION WILL CYCLE ALL EXTERIOR LAMPS EXCEPT BACK-UP LIGHTS - POWER SOURCE - FOR CUSTOMER INSTALLED LIFTGATE, 200 AMP MAX, INCLUDES 2 GAUGE POWER CABLE TO END OF FRAME WITH TIMEOUT FEATURE AND BATTERY DISCHARGE PROTECTION <p><u>MISCELLANEOUS</u></p> <ul style="list-style-type: none"> - DOMICILE - USA - 49 STATES (EXCLUDING CALIFORNIA AND CARB OPT-IN STATES) - BACK-UP ALARM - ELECTRIC - 102 dB - 4300 - 25,999 lb T4 STRAIGHT TRUCK - PENSKE AND FACTORY PREDELIVERY CHARGE - COMMODITY SURCHARGE - WILL CALL CHARGE - PENSKE T4 - PENSKE T4 <p><u>BASE SPEC</u></p> <ul style="list-style-type: none"> - BASE CHASSIS, MODEL 4300 SBA 4X2 <p><u>XATA</u></p> <ul style="list-style-type: none"> - NO SYSTEM SELECTED <p><u>QUALCOMM</u></p> <ul style="list-style-type: none"> - NO SYSTEM SELECTED - NO OEM PRE-WIRE SELECTED <p><u>VOCATION AND COMMODITY</u></p> <ul style="list-style-type: none"> - 10,000 lbs - 17,500 lbs - 25,999 lbs <p><u>COLORS & CODES:</u></p> <ul style="list-style-type: none"> - CAB [WHITE, 9219] - FRAME [CANYON BLACK, 0001] - WHEELS [WHITE, NONE] <p><u>ENGINE PARAMETERS:</u></p> <ul style="list-style-type: none"> - CRUISE: [70 MPH] - HORSE POWER: [225 HORSE POWER] - IDLETIME: [5 MIN] - PTO: [1000 RPM] - ROADSPEED: [70 MPH] - TORQUE: [560 FT/LB] | |
| <p>Schedule "S" annexed to and made a part of Vehicle Lease Service Agreement dated 03/08/2010 between Waste Management of Washington, Inc. and PENSKE TRUCK LEASING.</p> | | | |
| Waste Management of Washington, Inc. | Signature | Title | Date |
| | | ALBA VP | 09/17/10 |
| PENSKE TRUCK LEASING CO., L.P. | Signature | Title | Date |
| | | | |
| <p>THIS COPYRIGHT-PROTECTED WORK MAY NOT BE COPIED, REPRODUCED OR DISTRIBUTED WITHOUT WRITTEN CONSENT OF PENSKE TRUCK LEASING CO., L.P. ANY UNAUTHORIZED USE IS EXPRESSLY PROHIBITED AND SHALL BE CONSIDERED COPYRIGHT INFRINGEMENT</p> | | | |

| | | | |
|--|---|--|--------------------|
| Penske Truck Leasing Service Location - Street Address | | City, State and Zip Code | |
| TACOMA, WA | | | |
| MAKE | MORGAN | WEIGHT | 4810 LBS + or - 3% |
| MODEL | FRPVAN 24 FT | | |
| YEAR | 2010 | | |
| TYPE | FRPVAN 24 FT | | |
| BODY EXTERIOR - OUTSIDE BODY WIDTH - 102" - BODY COLOR EXTERIOR - PREPAINTED WHITE - ROOF - TRANSLUCENT SHEET- LASCO - REAR FRAME - WELDED, GALVANNEALED, PRIMED AND PAINTED - REAR VISION CAMERA SYSTEM WITH SOUND - COLOR - INCLUDES 5" IN CAB FLAT SCREEN MONITOR AND WEATHER RESISTANT REAR CAMERA - FRONT AND SIDE PANELS - FIBERGLASS REINFORCED PLYWOOD, 5/8" THICK PANEL, SMOOTH GELCOAT FINISH, INTERIOR AND EXTERIOR, WHITE INTERIOR - CORNERS (FRONT) - 5" ALUMINUM RADIUS, 0.063" THICK - WIRING - TRUCK-LITE, 10 YEAR WARRANTED, RETURN GROUND WIRING HARNESS, INCLUDING A 4-WAY TRAILER PLUG AT REAR FOR DRIVE-AWAY SERVICES - FULLY HARNESSSED - REFLECTORS - ULTRA THIN TAPE TYPE, WITH CONSPICUITY TAPE AT REAR, PER FMVSS-108 REGULATIONS - UNDERSTRUCTURE - 4" I-BEAM LONGITUDINALS, 3" I-BEAM CROSSMEMBERS ON 12" CENTERS WITH 10 GAUGE STEEL PAN OVER WHEEL AREA, MYLAR TAPE BETWEEN CROSSMEMBER AND BOTTOM RAIL - UNDERCOATING - FULL UNDERBODY - MOUNTING - TWO TAPERED HARDWOOD STRIPS AND U-BOLTS. U-BOLTS ARE TO BE PROPERLY TORQUED. MOUNT AS LOW AS POSSIBLE. THICKNESS OF WOOD STRIPS TO BE DETERMINED - GRAB HANDLE - REAR - ONE CURBSIDE AND ONE ROADSIDE - LIGHTS - L.E.D. LIGHTING PER FMVSS-108. AMBER AND RED CLEARANCE LIGHTS, PART # 21251 R/Y, LICENSE PLATE LIGHT, PART # 15041. LIGHTS RECESSED IN CORNER POSTS, RED TAIL LIGHT, PART # 60256R, BACK-UP LIGHT, PART # 66206C. - * Tool boxes - Two (2) 18" X 18" X 36" Mtd. one on C/S and one on R/S, under body frame. | | - NO SIDE DOOR - * REAR DOOR LOCKS LIFTGATE - MAXON - GPT-3 - 3,000 lb CAPACITY TUK-A-WAY WITH GREASABLE PINS - LEVEL RAMPING RIDE - POWER DOWN - 60" X 80" EXTRUDED ALUMINUM WEDGE PLATFORM - WITH DUAL CART STOPS (Will reduce platform area by 12" when activated) - MORGAN BS5504 NARROW STRUCTURAL LIFTGATE BUMPER WITH 2 SLIP RESISTANT STEPS - LIFTGATE EQUIPMENT - INCLUDES LOW VOLTAGE THERMAL SWITCH, HARD PLASTIC MOTOR COVER, SINGLE TOGGLE SWITCH ON CURBSIDE, WITH 3" X 24" RUBBER BUMPER BLOCKS MISCELLANEOUS - 3rd QUARTER MORGAN DISCOUNT - Orders received 07/01/10 - 09/30/10 - DELETE ALL BODY COMPANY, DOOR, FLOOR AND LIFTGATE LOGO, EXCEPT WHERE LEGALLY REQUIRED OR AGREED TO WITH SUPPLIER - FLOOR HEIGHT - DEPENDING ON TIRE SIZE, CHASSIS, AND APPLICATION, WITH A MINIMUM OF 5-1/2" OF TIRE CLEARANCE - MUD FLAPS - PLAIN BLACK, ANTI-SAIL - PENSKE CUSTOM - COMMODITY SURCHARGE COLORS & CODES: - CAB [NONE , NONE] - FRAME [BLACK , NONE] - BODY [WHITE , NONE] | |
| BODY INTERIOR - 103" HIGH (CANNOT BE USED WITH CHASSIS UNDER 15,000 lb GVW) - * 1-1/4" Extruded aluminum, inverted T, anti-skid floor option in lieu of standard floor. Seams are solid welded, there is a 6" high scuff plate/ end board and a glassboard subpan. - INSIDE BODY WIDTH - 100-1/4" - ROOF BOWS - ROLL FORMED, ONE INCH ON 24" CENTERS (ANTI-SNAG) - DOME LIGHT - (1) - RECESSED IN BRACKET WITH EXTRA ROOF BOW, CENTERED IN BODY, WIRED TO CHASSIS OEM SUPPLIED DASH SWITCH - DOME LIGHT - ADDITIONAL - WIRED ON THE SAME CIRCUIT (2) - E-TRACK - SURFACE MOUNTED - BOTH SIDES OF BODY (3) DOORS - REAR DOOR - WHITING - TWO CABLE PREMIUM PLASTIC CLAD OVERHEAD, SIDE SEALS, 4-POINT BOTTOM SEAL AND ALUMINUM RIVETS (IRON OR EQUIVALENT POLYURETHANE PAINT) | | | |
| Schedule "S" annexed to and made a part of Vehicle Lease Service Agreement dated 09/08/2010 between Waste Management of Washington, Inc. and PENSKE TRUCK LEASING. | | | |
| Waste Management of Washington, Inc. | Signature  | Title AREA VP | Date OCT 7 / 10 |
| PENSKE TRUCK LEASING CO., L.P. | Signature  | Title | Date |
| THIS COPYRIGHT-PROTECTED WORK MAY NOT BE COPIED, REPRODUCED OR DISTRIBUTED WITHOUT WRITTEN CONSENT OF PENSKE TRUCK LEASING CO., L.P. ANY UNAUTHORIZED USE IS EXPRESSLY PROHIBITED AND SHALL BE CONSIDERED COPYRIGHT INFRINGEMENT | | | |



VEHICLE LEASE SERVICE AGREEMENT

This Vehicle Lease Service Agreement is executed Mar 08, 2010, by and between PENSKE TRUCK LEASING CO., L.P., a Delaware limited partnership with an address at Route 10-Green Hills, P.O. Box 563, Reading, PA 19603-0563 ("Penske"), and Waste Management of Washington, Inc. (indicate which: () a corporation, () a partnership, a limited liability company under the laws of the State of WA with an address at 23 Port Orchard Street Port Orchard WA 98367 ("Customer"), and relates to the vehicle(s) described on the Schedule(s) "A" (the "Vehicle" or "Vehicles") annexed to this Vehicle Lease Service Agreement now or hereafter. As the Vehicles described in a Schedule "A" have been placed into Customer's service, Penske will provide Customer with the specific vehicle number, serial number and in-service date for each such Vehicle. The term "VLSA" means this Vehicle Lease Service Agreement and all Schedules attached hereto.

1. GENERAL; TERM AND EXPIRATION.

a. **Lease and Term.** Penske shall lease the Vehicles to Customer, and Customer shall lease the Vehicles from Penske, subject to the terms of this VLSA. The term of this VLSA for each Vehicle shall begin on the in-service date listed on the in-service documentation provided by Penske ("In-Service Date"), which shall be the date Penske notifies Customer that the Vehicle is available for delivery, and such term shall end on the last day of the calendar month that is the number of months identified in the "Lease Term Mn." column on Schedule "A" from the In-Service Date.

b. **Selection.** Customer has selected each Vehicle, including the accessories, features, and design requirements set forth on the Vehicle's Schedule "S", and has requested that Penske purchase each Vehicle for lease to Customer under this VLSA. Each Vehicle shall be made available to Customer at the Penske service location set forth on Schedule "A". Customer understands that the delivery date of a Vehicle is solely dependent on the manufacturer and Customer accepts that risk. If a Vehicle has been in Customer's service prior to its In-Service Date no Schedule "S" shall be attached. Except as may be agreed to by the parties, Penske shall have no liability or obligation with regard to any third party hardware or software installed in a Vehicle pursuant to its Schedule "S".

c. **Expiration and Return.** Upon expiration or termination of the Vehicle's lease, Customer shall return the Vehicle to the Penske location shown on Schedule "A" in the same condition and appearance as when received, ordinary wear and tear excepted, and shall pay to Penske all outstanding "Lease Charges" (as defined in Article 7.a below) through the date of return plus (i) all license and registration fees, applicable personal property taxes, and prepaid expenses paid by Penske with respect to the Vehicle, pro-rated to the date of expiration or termination, (ii) the cost of de-identification, re-painting, and returning the Vehicle to daily rental condition in accordance with Penske's established standards, and (iii) a pro-rated portion of any licenses or permits that cannot be used or transferred by Penske. If Customer retains a Vehicle after the expiration of its lease, all the terms of this VLSA shall apply to such hold-over period except that either party may terminate the hold-over lease at any time upon written notice to the other, at which time Customer shall return the Vehicle.

2. **PENSKE'S OBLIGATIONS.** Penske shall, at its expense, provide with respect to the Vehicles: (a) all preventive maintenance, replacement parts, and repairs to keep the Vehicles in good repair and operating condition, (b) oil and lubricants necessary for the efficient operation of the Vehicles, (c) all necessary tires, (d) road service because of mechanical and tire failures, (e) periodic exterior washing, and (f) initial painting and lettering of each Vehicle at a cost not exceeding the per-vehicle allowance specified on its Schedule "A". In the event a Vehicle shall be disabled for any reason, Customer and/or its driver shall immediately notify Penske. If a Vehicle is disabled because of mechanical or tire failure, Penske shall, within a reasonable period of time after receipt of notification, properly repair, or cause the repair of, the Vehicle. Penske shall have no responsibility for any repair or service to a Vehicle away from its facilities unless authorized by Penske and documented by an itemized bill for such repairs or services.

3. **CUSTOMER OBLIGATIONS.** Customer shall not cause or permit any person other than Penske or persons authorized by Penske to make any repairs to a Vehicle, and shall abide by Penske's directions concerning emergency repairs. Customer will cause its drivers to (a) promptly report any trouble concerning a Vehicle on forms provided by Penske and (b) check oil and coolant levels in each Vehicle on a daily basis. Customer will return each Vehicle to Penske at the service location set forth on its Schedule "A", or as otherwise directed by Penske, for inspection, preventive maintenance, and repair every month at scheduled times as are mutually agreed upon. Should Customer move the base of operation of a Vehicle from the domicile shown on its Schedule "A" or change the nature of a Vehicle's operation as described on its Schedule "A", Penske shall have the right to either make adjustments to the rates to compensate for such changes or terminate this VLSA with respect to the affected Vehicle. Title to the Vehicles shall remain in the name of Penske or its designee. Customer shall, at all times and at its sole cost, keep the Vehicles free and clear from all liens, encumbrances, levies, attachments, or other judicial process from every cause whatsoever (other than a claimant through an act of Penske).

4. SUBSTITUTE, EXTRA AND INTERIM VEHICLES.

a. **Substitute Vehicles.** If a Vehicle is temporarily disabled because of mechanical failure and if such Vehicle's Schedule "A" requires Penske to provide a substitute for such Vehicle ("Substitute"), Penske shall furnish a Substitute in as nearly as practicable the same size and type as the inoperable Vehicle. The Substitute will be provided at no extra charge, except that Customer shall be responsible for paying mileage charges for the Substitute at the same rate as for the disabled Vehicle and the fixed charges for the disabled Vehicle shall not abate. Penske shall not be required to letter, paint, or alter any Substitute. The Substitute shall be furnished to Customer whenever possible at the place at which the original Vehicle was disabled and shall be returned by Customer to the facility from which it was provided or the facility at which the repaired Vehicle is made available, as Penske may designate. Penske shall have no obligation to provide a Substitute if the inoperable Vehicle is out of service: (i) because of damage resulting from collision or upset, or (ii) for preventive maintenance or service or for service or repairs to equipment for which Penske has no responsibility, or (iii) as a result of Customer's violation of any of the terms of this VLSA.

b. **Extra Vehicles.** At Customer's request, Penske will rent additional vehicles ("Extras") to Customer for temporary use to the extent Penske has available sufficient vehicles of the size and type requested at the Penske facility that services Customer. Penske shall not be required to letter, paint, or alter any Extra. The rental rate to be paid by Customer for the use of an Extra shall be Penske's then prevailing daily rental rate for such vehicles in effect at the location from which the Extra is obtained less fifteen percent (15%), plus all license and registration fees, applicable personal property taxes, and prepaid expenses paid by Penske with respect to the Extra, if not included in such rate. Penske shall have no obligation to provide Extras that are specialized vehicles.

c. **Interim Vehicles.** During the period prior to a Vehicle being made available to Customer, Penske will, at Customer's request, rent an interim vehicle ("Interim") to Customer, if available in as nearly as practical the same size and type as the leased Vehicle. Penske shall not be required to letter, paint, or alter any Interim. Miles operated by an Interim will not be included in determining whether the leased Vehicle for which the Interim was provided satisfied any mileage guaranty applicable to it. The rental rate to be paid by Customer for the use of an Interim shall be equal to the Lease Charges for the leased Vehicle, plus all license and registration fees, applicable personal property taxes, and prepaid expenses paid by Penske with respect to the Interim. Customer shall immediately return the Interim when Penske makes the leased Vehicle available and, if the Interim is not returned, Penske may, in addition to other remedies under this VLSA, treat such vehicle as an Extra under this VLSA.

d. Rental Agreements. Penske may require Customer to execute a rental agreement whenever Customer requests an Extra, Substitute, or Interim. Notwithstanding the execution of a rental agreement, all Extras, Substitutes, and Interims will be considered Vehicles subject to the terms and conditions of this VLSA and not the rental agreement.

5. FUEL.

a. The Party to Provide Fuel. If Penske is designated on a Vehicle's Schedule "A" to provide fuel, Penske shall provide Customer fuel for the Vehicle, including refrigeration units, at charges that vary over time from Penske facilities or from facilities participating in the Penske Fuel Stop Program and invoice Customer for the charges and all applicable taxes and fees for the fuel. Customer may also procure fuel from other sources at its own expense. If Customer is past due on payment of any invoices rendered by Penske or if an "Event of Default" (as defined in Article 13.a below) has occurred, Penske may (in addition to any other remedy under this VLSA) immediately discontinue providing fuel to Customer.

b. Fuel Cards. If Penske provides Customer with any fuel cards for the purchase of fuel, Customer shall be fully responsible for all purchases made under such fuel cards, even if made improperly or illegally. Customer shall immediately report lost or stolen fuel cards to Penske. If Customer fails to pay fuel card charges when due, Penske may (in addition to any other remedy under this VLSA) immediately cancel Customer's fuel cards.

6. LICENSES, TAXES, PERMITS AND TOLLS. Penske shall, at its own expense, register and title each Vehicle and pay for any Vehicle inspection fees in the state of registration of such Vehicle for the licensed weight shown on its Schedule "A". Customer shall reimburse Penske for all amounts it pays for licenses, taxes, permits or fees (including but not limited to Federal Highway Use Tax and personal property tax) imposed upon the operation or use of each Vehicle, this VLSA, or the Lease Charges that are (a) not set forth on the Vehicle's Schedule "A" or (b) in excess of the amounts included in the fixed lease charge for such licenses, taxes, permits or fees shown on the Vehicle's Schedule "A". Customer shall provide Penske with all documentation required for Vehicle licensing, taxes and permits. If Penske is designated on a Vehicle's Schedule "A" to provide fuel tax reporting for such Vehicle, Penske shall apply for fuel tax permits for such Vehicle and bill their cost to Customer. Penske shall prepare and file mileage and fuel tax returns, for which Customer shall submit weekly driver trip records, original fuel receipts or invoices, and any other information necessary for the preparation of the fuel tax returns (collectively, "Mileage and Fuel Tax Documents"). The obligation to provide Mileage and Fuel Tax Documents shall apply to all Vehicles, Substitutes, Extras, and Interims. If Customer fails to submit the Mileage and Fuel Tax Documents, Penske may estimate Customer's mileage and fuel tax liability based upon such information as is available to Penske. Penske shall have the right upon 30 days' prior notice to stop providing any of the services set forth in this Article 6. Customer shall be liable for the payment of any and all tolls associated with the use and operation of the Vehicle, and for the payment of any and all fines, fees, costs or expenses related to toll evasion or any other traffic violations.

7. LEASE CHARGES.

a. Lease Charges. As used in this VLSA, "Lease Charges" means the fixed lease charges, mileage charges, hourly charges, refrigeration charges, fuel charges, mileage and fuel tax obligations, and any and all other amounts and charges listed on Schedule "A" and/or described elsewhere in this VLSA.

b. Invoices: Payment. Customer shall pay Penske all Lease Charges within seven (7) days of the date of Penske's invoice, without deduction or offset. Penske shall (except for fuel charges, which shall be invoiced weekly, and other amounts and charges for which a different invoicing frequency is specified in this VLSA) invoice Customer for Lease Charges on a monthly basis, including the billing of fixed lease charges in advance and refrigeration and mileage charges in arrears. If an Event of Default occurs, Penske may invoice Customer on a weekly basis. Customer shall pay Lease Charges to the location designated by Penske, and all payments shall be made in the form of check, electronic funds transfer or ACH payment; cash or credit cards shall not be accepted for payment. Unless Customer protests the correctness of any invoice within thirty (30) days of its receipt, such invoice shall be presumed to be correct. Unless the parties agree otherwise or unless Customer does not obtain fuel from Penske, Penske will determine the mileage and (if applicable) the refrigeration hours for each Vehicle. If Customer does not obtain fuel from Penske, Customer shall provide mileage readings and (if applicable) refrigeration hour readings for each Vehicle on at least a monthly basis.

c. Overtime Charges. Each Vehicle shall be operated according to the Estimated Annual Mileage/Vehicle ("EAM") as listed on its Schedule "A". If at the expiration or termination of the term of this VLSA for a Vehicle the actual miles operated by such Vehicle exceeds its total EAM for the term by five percent (5%), Customer shall pay Penske \$0.10 for each mile over the total EAM for the term, in addition to the mileage charges due under this VLSA.

d. Excess Refrigeration Charges. If a Vehicle has a refrigeration unit, such unit shall be operated according to the Estimated Annual Refrigeration Hours/Vehicle ("EARH") as listed on its Schedule "A". If at the expiration or termination of the term of this VLSA for such Vehicle the actual refrigeration hours operated by such Vehicle's refrigeration unit exceeds its total EARH for the term, Customer shall pay Penske \$0.50 for each engine running hour, and \$0.15 for each standby hour, over the total EARH for the term, in addition to the refrigeration charges per hour due under this VLSA.

e. Deposit. Upon the occurrence of an Event of Default and notwithstanding any amendment to this VLSA to the contrary, Customer shall thereafter pay Penske per the terms set forth in this Article 7 and Customer shall, if requested, provide Penske with a deposit against future invoices in an amount equal to not less than the total amount invoiced by Penske in the three (3) months prior to the occurrence of the Event of Default.

8. VEHICLE USE AND DRIVERS. From the time a Vehicle is made available to Customer until its return to Penske upon termination or expiration of its lease, Customer shall have exclusive possession, control, and use of such Vehicle. Customer shall not make any alterations to a Vehicle. Vehicles shall be operated by safe, qualified, properly licensed drivers, who shall conclusively be presumed to be Customer's agents, servants or employees only, and subject to Customer's exclusive direction and control. Vehicles shall not be operated: (a) by a driver in possession of or under the influence of alcohol or any controlled drug, substance or narcotic, (b) in a reckless or abusive manner, (c) off an improved road, (d) on an underinflated tire, (e) with insufficient coolant or oil, (f) while improperly loaded or loaded beyond maximum weight shown on the Schedule "A", or (g) in violation of any applicable laws, ordinances, or rules. Customer shall reimburse Penske for any damage or expenses, and shall protect, defend, indemnify and hold Penske and its partners harmless from and against all fines, claims, forfeitures, judgments, seizures, confiscations and penalties, arising out of the failure to adhere to the requirements of the preceding sentence. Customer shall be responsible for all expenses for removing or towing any mired or snowbound Vehicle. If Customer operates a Vehicle with a trailer or other equipment not leased by Penske under this VLSA, Customer warrants that such trailer or other equipment shall be in good operating condition compatible in all respects with the Vehicle with which it is used and in compliance with all applicable laws and regulations, and shall be responsible for all repairs and/or additional maintenance resulting from such use or from any defects in such trailer or equipment. Customer shall not use or permit any Vehicle to be used (x) for the transportation of "hazardous materials" (as defined by regulations promulgated by the United States Department of Transportation), gasoline, or propane, or (y) for any illegal purpose. Customer shall store each Vehicle in a safe location.

9. PHYSICAL DAMAGE AND LIABILITY COVERAGE.

a. Responsibility for Damage; Insurance. Customer assumes the risk of loss of, or damage to, all Vehicles from any and every cause whatsoever, notwithstanding Section 2A-219(f) of the UCC, including, but not limited to, casualty, collision, upset, fire, theft, malicious mischief, vandalism, graffiti, glass breakage, and mysterious disappearance, except as otherwise provided in this VLSA. Unless Penske gives written permission to self-insure these obligations, Customer shall at its sole cost procure and maintain an automobile collision and comprehensive insurance policy protecting Penske and its partners against any and all loss or damage to each Vehicle, in form satisfactory to Penske and in an amount equal to the "Depreciated Schedule 'A' Value" (as defined below) of such Vehicle, which policy shall name Penske and/or its assignee as loss payee. "Depreciated Schedule 'A' Value" of a Vehicle means (i) the Original Agreed Value set forth on its Schedule "A" less (ii) the Depreciation Credit per Month set forth on such Schedule "A" multiplied by the number of months elapsed from the Vehicle's In-Service Date to the date as of which the Depreciated Schedule "A" Value is being determined.

including other fees described by Penske), and in Penske's judgment a vehicle has been lost, stolen, destroyed, or damaged beyond repair, Customer shall pay Penske (i) all Lease Charges accruing to the date of Penske's receipt of payment in full for such Vehicle and (ii) the Depreciated Schedule "A" Value of such Vehicle immediately preceding the casualty occurrence; upon Penske's receipt of such payments, this VLSA shall terminate as to such Vehicle and the Vehicle shall become the property of Customer, as-is, where-is.

c. **Liability Coverage.** Customer shall at its sole cost procure and maintain liability coverage for each Vehicle, protecting Customer and Penske and its partners and their respective agents, servants and employees, in accordance with the standard provisions of a basic automobile liability insurance policy as required in each jurisdiction in which the Vehicle is operated, against liability for bodily injury, including death, and property damage arising out of the ownership, maintenance, use and operation of each Vehicle with limits of at least a combined single limit of One Million Dollars (\$1,000,000.00) per occurrence. Such coverage shall be primary and not excess or contributory and shall be in conformity with the motor vehicle minimum financial responsibility laws as respects "Uninsured Motorist", "No-Fault", or other optional coverages. Such coverage shall be endorsed to include Penske as an additional insured and shall be in a form acceptable to Penske.

d. **Certificates of Insurance.** Prior to delivery of any Vehicle, Customer shall deliver to Penske certificates of insurance showing the coverages required pursuant to paragraphs a and c of this Article 9. Each insurer shall agree, by endorsement upon the policy issued by it or by an independent document provided to Penske, that it shall give Penske thirty (30) days' prior written notice of the effective date of any cancellation or material alteration of such policy, and that such notice shall be sent by registered or certified mail postage prepaid, return receipt requested, to Penske Truck Leasing Co., L.P., Route 10-Green Hills, P.O. Box 563, Reading, PA 19603-0563, Attention: Insurance Risk Management Department.

e. **Notification of Accidents.** Customer shall notify Penske as well as Customer's insurance carrier of any loss of, damage to, or accident involving any Vehicle; such notice shall be effected immediately by telephone, and in writing as soon as practical thereafter. Customer shall cooperate fully in the investigation, prosecution, and/or defense of any claim or suit arising out of any such occurrence and shall do nothing to impair or invalidate any applicable liability, physical damage, or cargo coverage.

10. INDEMNIFICATION. FOR LIABILITY IN EXCESS OF THE LIMITS OF THE INSURANCE REQUIRED IN ARTICLE 9 ABOVE, OR IN THE EVENT THERE IS NO INSURANCE COVERAGE OR CUSTOMER FAILS TO PROVIDE A DEFENSE, CUSTOMER SHALL PROTECT, DEFEND, INDEMNIFY AND HOLD HARMLESS PENSKE AND ITS PARTNERS AND THEIR RESPECTIVE OFFICERS, DIRECTORS, SHAREHOLDERS, AGENTS, SERVANTS, REPRESENTATIVES AND EMPLOYEES FROM ANY AND ALL CLAIMS, SUITS, COSTS, LOSSES, DAMAGES, EXPENSES (INCLUDING REASONABLE ATTORNEYS' FEES) AND LIABILITIES (EVEN IF PENSKE IS CLAIMED TO HAVE BEEN OR IS PROVEN TO BE NEGLIGENT) ARISING FROM: (A) CUSTOMER'S FAILURE TO COMPLY WITH ITS OBLIGATIONS TO GOVERNMENTAL BODIES HAVING JURISDICTION OVER CUSTOMER AND THE VEHICLES, (B) CUSTOMER'S FAILURE TO COMPLY WITH THE TERMS OF THIS VLSA, (C) THE OWNERSHIP, USE, SELECTION, POSSESSION, MAINTENANCE, AND/OR OPERATION OF ANY VEHICLE, (D) ANY LIABILITY IMPOSED UPON OR ASSUMED BY CUSTOMER UNDER ANY WORKER'S COMPENSATION ACT, PLAN OR CONTRACT AND ANY AND ALL INJURIES (INCLUDING DEATH) OR PROPERTY DAMAGE SUSTAINED BY CUSTOMER OR ANY DRIVER, AGENT, SERVANT OR EMPLOYEE OF CUSTOMER, OR (E) LOSS OR DAMAGE INCURRED BY PENSKE FROM CUSTOMER'S USE OF A VEHICLE OR TRAILER NOT OWNED OR INSURED BY PENSKE, REGARDLESS OF PENSKE'S OBLIGATIONS IMPOSED BY THE INSURANCE PROVISIONS OF ANY FEDERAL OR STATE AGENCY. CUSTOMER'S OBLIGATIONS UNDER THIS ARTICLE 10 SHALL SURVIVE THE TERMINATION OR EXPIRATION OF THIS VLSA.

11. REGULATIONS/RECALLS. If any law, rule, regulation, or manufacturer's recall shall require the modification of any Vehicle or the installation of any additional equipment or accessories, including, but not limited to, anti-pollution and/or safety devices, Customer shall make such Vehicle available and pay Penske for the installation of such equipment or the performance of such modifications, as well as any ongoing maintenance expenses related to such equipment or modifications.

12. FORCE MAJEURE. Neither party shall incur liability to the other party for a failure to perform any obligations under this VLSA (excluding payment and insurance obligations) that is caused by events beyond such party's reasonable control, such as (but not limited to) war, terrorist attack, fire, governmental regulations, acts of God, labor disputes, manufacturer, supplier or transportation shortages or delays, fuel allocation programs, or manufacturer's defects.

13. DEFAULT AND REMEDIES.

a. **Event of Default.** An "Event of Default" shall occur if (i) Customer fails to pay any Lease Charges when due or to maintain any insurance coverage required under VLSA, or (ii) Customer fails to perform any other term of this VLSA and such failure continues for five (5) days after written notice thereof is sent to Customer, or (iii) Customer or any guarantor of Customer's obligations becomes insolvent, makes a bulk transfer or other transfer of all or substantially all of its assets or makes an assignment for the benefit of creditors, or (iv) Customer or any guarantor of Customer's obligations files or suffers the filing against it of a petition under the Bankruptcy Code or under any other insolvency law or law providing for the relief of debtors, or (v) any representation or warranty made by Customer in this VLSA or in any document furnished to Penske by Customer or any guarantor of Customer's obligations is incorrect in any material respect.

b. **Remedies.** Upon the occurrence of an Event of Default, Penske shall not be required to perform its obligations under this VLSA and may immediately terminate this VLSA and/or proceed by appropriate court action to enforce the terms of this VLSA and/or to recover damages for the breach of any of its terms. In addition, Penske may, with or without terminating this VLSA, with or without demand or notice to Customer, and with or without any court order or process of law, take immediate possession of any or all Vehicles wherever located, without being liable to Customer for damages caused by such taking of possession. If any such Vehicle contains any property belonging to Customer or in Customer's custody or control, Penske is authorized to hold the items for Customer or place them in storage for Customer, at Customer's sole cost and risk of loss or damage. Penske may also, with or without terminating this VLSA, require Customer upon five (5) days' written notice to, at Penske's option, either purchase any or all of the Vehicles or make the "Alternative Payment" as set forth in Article 14.a below for any or all of the Vehicles, and in addition pay the total of the Lease Charges for all such Vehicles accruing up to the date upon which Customer could have terminated this VLSA under Article 14.a, together with all Lease Charges due and unpaid to the date of Penske's notice to Customer under this paragraph.

c. **Interest; Attorneys' Fees.** Should Customer fail to pay any Lease Charges when due, Customer shall be liable for interest on such delinquent amounts at the rate of one and one-half percent (1.5%) per month or the maximum permissible rate allowed in the jurisdiction in which Customer's principal place of business is located, whichever is lower, from the date on which payment was due until paid. If Penske initiates legal action against Customer as the result of an Event of Default, Penske shall be entitled to reimbursement from Customer of all expenses of collection and reasonable attorneys' fees.

14. TERMINATION PRIVILEGES.

a. **Right to Terminate.** Either party may, upon sixty (60) days' prior written notice to the other, terminate this VLSA as to a Vehicle on any annual anniversary of such Vehicle's In-Service Date. Upon termination by either party, Customer shall, at Penske's option, either (i) purchase the Vehicle as to which the notice has been given (other than a Substitute, Interim, or Extra) at the Vehicle's Depreciated Schedule "A" Value, as is, where is, or (ii) pay Penske the "Alternative Payment" (as defined in the next sentence) for such Vehicle. The "Alternative Payment" shall be the difference, if any, between the Vehicle's Depreciated Schedule "A" Value at the termination date and the Vehicle's "Fair Market Value" ("Fair Market Value" shall be the highest bona fide offer to purchase such Vehicle received by Penske as of the date of termination).

b. **Termination Amounts.** In addition to paying the purchase price or making the Alternative Payment for a Vehicle, Customer shall also pay all outstanding Lease Charges through and including the date of purchase or date the Alternative Payment is made, together with (i) applicable sales or use taxes, (ii) all license and registration fees, applicable personal property taxes, unrepaid expenses paid by Penske with respect to the Vehicle, pro-rated to the date of termination, (iii) the cost of de-identification, re-painting, and restoring the Vehicle to daily rental condition in accordance with Penske's established standards (including the loss of use of such Vehicle during such restoration), and (iv) a pro-rated portion of any licenses or permits that cannot be used or transferred by Penske (collectively, "Termination Amounts"). Customer shall have no right to exercise any option to terminate this VLSA under this Article if an Event of Default has occurred. No termination of this VLSA by either party shall release Customer of liability for the payment of any sums due Penske or any damages that Penske shall have sustained by reason of Customer's breach thereof.

15. **ADJUSTED COST.** For each rise or fall of at least one percent (1%) in the Consumer Price Index for All Urban Consumers for the United States published by the United States Department of Labor, Bureau of Labor Statistics ("CPI"), or any successor index designated by Penske, above or below the CPI figure applicable for each leased Vehicle as of the "Effective Date" indicated on its Schedule "A", the Lease Charges for such Vehicle shall be adjusted upward or downward based upon such percentage increase or decrease in the CPI. Seventy-five percent (75%) of the fixed lease charge, one hundred percent (100%) of the basic mileage charge, one hundred percent (100%) of any excess or undermileage charge (per mile), and one hundred percent (100%) of the refrigeration charge, if applicable, shall be subject to adjustment. All increases under this Article shall be cumulative and shall be calculated only on the charges initially shown on the Vehicle's Schedule "A". Adjustments shall be implemented semi-annually on January 1 and July 1. Upon adjustment, the fixed lease charge shall be rounded off to the nearest whole cent and all adjustments in the basic mileage, excess mileage, and undermileage charges shall be rounded off to the nearest tenth of a mil.

16. **NON-LIABILITY FOR CONTENTS.** Penske shall not be liable for loss of, or damage to, any cargo or other property left, stored, loaded or transported in, upon, or by any Vehicle at any time or place.

17. **ASSIGNMENT AND SUBLETTING.**

a. **By Customer.** WITHOUT THE PRIOR WRITTEN CONSENT OF PENSKE, WHICH CONSENT WILL NOT BE UNREASONABLY WITHHELD, CUSTOMER SHALL NOT VOLUNTARILY OR INVOLUNTARILY ASSIGN OR PLEDGE THIS VLSA OR THE VEHICLES, OR SUBLET, RENT OR LICENSE THE USE OF THE VEHICLES, OR UNDERGO A CHANGE OF CONTROL THAT WOULD OTHERWISE ASSIGN THIS VLSA BY OPERATION OF LAW OR CAUSE OR PERMIT THE VEHICLES TO BE USED BY ANYONE OTHER THAN CUSTOMER OR ITS LEASED DRIVERS, SERVANTS OR EMPLOYEES.

b. **By Penske.** This VLSA and any Vehicles, rent, or other sums due or to become due hereunder may be assigned or otherwise transferred, either in whole or in part, by Penske, without affecting any obligations of Customer and, in such event, Customer's rights shall be subject to any lien, security interest or assignment given by Penske in connection with the ownership of the Vehicle(s), and the transferee or assignee shall have all of the rights, powers, privileges and remedies of Penske.

18. **DISCLAIMER.** PENSKE MAKES NO WARRANTY OF ANY KIND, EXPRESS OR IMPLIED, AS TO THE MERCHANTABILITY, FITNESS FOR ANY PARTICULAR PURPOSE OR ABSENCE OF ANY MANUFACTURING DEFECTS OF ANY VEHICLE COVERED BY THIS VLSA. PENSKE AND ITS PARTNERS SHALL NOT BE LIABLE FOR LOSS OF CUSTOMER'S PROFITS OR BUSINESS, LOSS OR DAMAGE TO CARGO, LOSS OR DAMAGE RESULTING TO CUSTOMER BY REASON OF DELAY IN DELIVERY OR FAILURE TO DELIVER PRODUCTS OWNED OR TRANSPORTED BY CUSTOMER, DRIVER'S TIME OR ANY INDIRECT, SPECIAL OR CONSEQUENTIAL DAMAGES.

19. **MISCELLANEOUS.** This VLSA (including all the schedules attached hereto) shall be considered to be a single integrated contract and constitute the entire agreement between the parties regarding the Vehicles. Upon execution by Penske and Customer, this VLSA shall be binding on the respective parties and their legal representatives, successors and assigns and its terms shall not be amended or altered by failure of either party to insist on performance, or failure to exercise any right or privilege, or in any manner unless such amendment or alteration is in writing and signed on behalf of the parties hereto. Time shall be of the essence of this VLSA. No waiver or breach of any covenant or obligation herein shall be construed to be a waiver of the covenant or obligation itself, or any subsequent breach thereof. This VLSA shall supersede any and all proposals or agreements, written or verbal, between the parties, relating to the subject matter hereof and may not be modified, terminated or discharged, except in a writing signed by the party against whom the enforcement of the modification, termination or discharge is sought. Any notice required hereunder shall be sent by certified mail or overnight mail to the address written above (except that notices sent to Penske via overnight courier shall be sent to Route 10 and Pheasant Road, Reading, PA 19607) or such other address as either party shall furnish and shall be deemed delivered upon deposit in the United States mail or confirmed receipt by the overnight courier. This VLSA is to be interpreted, construed and enforced in accordance with the laws of the Commonwealth of Pennsylvania. In the event any of the terms and provisions of this VLSA are in violation of or prohibited by any law, statute, regulation, or ordinance of the United States and/or state or city where the VLSA is applicable, such terms and provisions shall be deemed amended to conform to such law, statute, regulation, or ordinance without invalidating any of the other terms and provisions of this VLSA.

IN WITNESS WHEREOF, the parties have caused this VLSA to be executed by their duly authorized representative as of the date first above written.

PENSKE TRUCK LEASING CO., L.P.

CUSTOMER: Waste Management of Washington, Inc.

Signature: _____

Signature: _____

Title: _____

Title: _____

Witnessed Or Attested By: _____

Witnessed Or Attested By: _____

1. It is agreed that the Schedule A Original Value, Depreciation and Fixed Charge set forth on this Schedule A & B are based upon manufacturer's quoted price for the Vehicle(s) as of the date of execution by Customer of this Schedule A & B. In the event the manufacturer's quoted price for such Vehicle(s) is increased prior to the In-Service Date of the Vehicle(s), Customer agrees that for each \$50 increase in price (or fraction thereof), the following shall be increased accordingly:

| | | |
|---------------------------|------------------------|----------------------|
| Schedule A Original Value | Fixed Charge Per Month | Monthly Depreciation |
| Redacted | Redacted | Redacted |

2. It is agreed that the rate of interest as of the date of Customer signature of this Schedule A & B is 0.50% as set forth by the two-year U.S. Treasury rate as published in the Wall Street Journal. In the event the interest rate should increase or decrease prior to the In-Service Date of the Vehicle(s), Customer agrees that for each quarter-point change (0.25%) in the interest rate, the fixed charge per month will be adjusted \$7.74.

3. Insurance

| | |
|--|------------------------------------|
| Liability Responsibility | Customer |
| Combined Single Limits | \$1,000,000.00 Per Occurrence |
| Excess or Umbrella | \$0.00 Per Occurrence |
| Physical Damage Insurance Responsibility | Customer |
| Maximum Deductible(s): | \$2,500.00 Comprehensive/Collision |

If PacLease has responsibility for the coverage described in this paragraph, a copy of the insurance policy is available for inspection at its office upon request of Customer, and Customer, being an insured under said policy agrees to comply with and be bound by all the terms, conditions, liabilities and restrictions thereof, all of which are hereby incorporated by reference and made a part hereof as though fully set forth at length, including those terms, conditions and restrictions of which no specific mention is made hereunder.

- 4. The Vehicle(s) listed on this Schedule shall be domiciled at the following address:
8111 1st Avenue
Seattle, WA, 98108
- 5. Service and maintenance location of the Vehicle(s) listed on this Schedule:
Rush Truck Leasing, Inc.
7837 East Telegraph Road
Pico Rivera, CA, 90660

Rush Truck Leasing, Inc.
(PacLease)

(Signature)
James R. Smith, Division General Manager

(Print Name & Title of Signing Authority)

(Date Signed)

6. Mileage guarantee. Customer grants that each of the Vehicles described on this Schedule A & B will be operated a minimum of 45,000 miles within each 12 month period ("Guarantee Period") during which it is under lease. The payment of the Mileage Rate per mile should be made for actual miles operated. A settlement of the mileage guarantee will be made at the end of each Guarantee Period as follows:
If miles actually operated during the period are less than the miles guaranteed, Customer will be billed by PacLease and Customer shall promptly pay to PacLease an amount equal to the difference between the number of miles guaranteed and the number of miles operated during the period, multiplied by the Over Mileage rate of \$0.0000 per mile.

7. Maximum mileage. Customer agrees that each of the Vehicles described on this Schedule A & B will be operated a maximum of 55,000 miles within each 12 month period during which it is under lease. If miles actually operated during the period are more than the miles specified above, Customer shall, upon receipt of PacLease's invoice, promptly pay to PacLease an amount equal to the difference between the number of miles specified and the number of miles operated during the period, multiplied by the over miles rate specified below. The Over Mileage rate shall be \$0.1000 per mile, in addition to the then current mileage rate.

8. Refrigeration Charges: Customer agrees that each unit equipped with a refrigeration unit will be operated a maximum of 0 engine hours and 0 standby hours within each 12 month period during which it is under lease. If hours operated are in excess of hours indicated above, Customer shall, upon receipt of PacLease's invoice, promptly pay to PacLease an amount equal to the difference between the number of hours specified and the number of hours operated during the period, multiplied by the excess refrigeration rate as follows: \$0.500 per engine running hour and \$0.150 per standby hour, in addition to the then current hourly rate(s).

9. The owner of the Vehicle(s) covered by this Schedule A & B is PACCAR Leasing Company. This Schedule A & B (including pages 1 of 2) is hereby made a part of the certain Agreement entered into between the parties as of the 11th day of March, 2011.

10. At the time of vehicle in-service Customer will be provided an In-Service Notification that will list unit numbers, in-service date(s) and 17 digit serial number(s). Execution of this schedule grants PacLease the authority to order and purchase the equipment described hereon and Customer agrees to accept equipment when delivered.

11. The lessee of this heavy-duty tractor understands that when using a heavy-duty tractor to pull a 53-foot or longer box-type trailer on a highway within California, the heavy-duty tractor must be compliant with sections 95300 - 95311, title 17, California Code of Regulations, and that it is the responsibility of the lessee to ensure this heavy-duty tractor is compliant. The regulations may require this heavy-duty tractor to have low rolling resistance tires that are U.S. Environmental Protection Agency (U.S. EPA) Verified SmartWay Technologies prior to current or future use in California, or may entirely prohibit use of this tractor in California if it is a model year 2011 or later tractor and is not a U.S. EPA Certified SmartWay tractor.

12. The lessee of this box-type trailer understands that when using a heavy-duty tractor to pull a 53-foot or longer box-type trailer on a highway within California, the box-type trailer must be compliant with sections 95300 - 95311, title 17, California Code of Regulations, and that it is the responsibility of the lessee to ensure this box-type trailer is compliant. The regulations may require this trailer to have low rolling resistance tires and aerodynamic technologies that are U.S. Environmental Protection Agency Verified SmartWay Technologies prior to current or future use in California.

Waste Management of Washington, Inc.
(Customer)

(Signature)
Dean Kattler, Vice President

(Print Name & Title of Signing Authority)

(Date Signed)

Exhibit 12

WASHINGTON STATE UTILITIES AND TRANSPORTATION COMMISSION

1300 S EVERGREEN PARK DRIVE SW, PO BOX 47250

OLYMPIA, WA 98504-7250

(360) 664-1222

This permit authorizes the following operations under the provisions of RCW Title 81:

Waste Management of Washington, Inc.
d/b/a Waste Management of Ellensburg,
Waste Management of Greater Wenatchee,
Waste Management of Spokane, Waste Management-Rainier,
Waste Management-Northwest, Waste Management-Sno-King,
Waste Management of Kennewick, North Cascade Disposal,
Recycle America, Rural Skagit Sanitation,
Federal Way Disposal, Nick Raffo Garbage, R.S.T. Disposal,
Tri-Star Disposal, Western Refuse, Port-O-Let,
Stanwood Camano Disposal, Waste Management,
Waste Management of Seattle, Waste Management
of Skagit County, Waste Management of Yakima,
Washington Waste Hauling & Recycling,
Brem-Air Disposal, Federal Way Disposal,
Nick Raffo Garbage, North Cascades Disposal,
Olson's Sanitation Service, R.S.T. Disposal,
Recycle America, Rural Skagit Sanitation,
Stanwood Camano Disposal, Tri-Star Disposal,
Valley Garbage, Washington Waste Hauling & Recycling,
Waste Management, Waste Management-Northwest,
Waste Management-Rainier, Waste Management-Sno-King,
Waste Management-South Sound, Waste Management of Addy,
WM Healthcare Solutions of Washington
13225 NE 126th Place
Kirkland, WA 98034

Cert No.
G-237

THIS CERTIFICATE DOES NOT AUTHORIZE REFUSE COLLECTION SERVICE RESTRICTED TO EXTREMELY HAZARDOUS SEMI-SOLID WASTE, INCLUDING ACIDS, CHEMICALS, AND RESIDUALS IN PIERCE, KING, SNOHOMISH AND WHATCOM COUNTIES AND INTERCOUNTY AND/OR HAZARDOUS INDUSTRIAL LIQUID, INCLUDING ACIDS, CHEMICALS AND RESIDUALS (NOT TO EXCEED 6,500 GALLONS IN BULK PER SHIPMENT)

SERVICE DATE
JAN 07 2011

WASHINGTON UTILITIES AND TRANSPORTATION
COMMISSION



By _____

A handwritten signature in black ink, appearing to read "L. W. [unclear]", written over a horizontal line.

*NOTE: A copy of this permit **MUST** be carried in each vehicle being operated under this authority.*

WM000001

WASHINGTON UTILITIES AND TRANSPORTATION COMMISSION

Continuation Page

IN WHATCOM, SKAGIT, SNOHOMISH, KING, KITSAP AND PIERCE COUNTIES AND INTERCOUNTY.

(PID277) SOLID WASTE COLLECTION SERVICE in Sections 6, 7, 18, the north ½ of 19 and those portions of Section 4 and 5 situated in King County, all in T. 22 N., R. 11 E.; and Sections 28, 29, 30, 31, 32 and the West ½ of Sec. 33, all in T. 23 N., R. 11 E., in King County.

(PID295) ALSO In that portion of King County, described as follows:

Commencing at the northeast City Limits of Auburn, and the Green River Banks within Section 8, T. 21 N., R. 5 E.; thence easterly along the Green River Banks to the northwest corner of Section 20, T. 21 N., R. 7 E., W.M.; thence north to the northwest corner of Section 20, T. 22 N., R. 7 E., W.M.; thence due east to the northeast corner of Section 24, T. 22 N., R. 7 E.; thence south to the southerly boundary of King County; thence westerly along the southerly boundary of King County to the southwest corner of Section 32, T. 21 N., R. 5 E., W.M.; thence northerly along the west line of said Section 32, 29, 20, 17 and 8 of T. 21 N., R. 5 E. to the Green River Banks to the point of beginning.

(PID297) ALSO in that portion of King County described as follows:

Commencing at the northwest City Limits of Renton and the shore of Lake Washington; thence northerly along the shore of Lake Washington to the City Limits of Bellevue (as of September 1, 2004); thence east along the south City Limits of Bellevue (as of September 1, 2004) to their intersection with the City Limits of Issaquah (as of September 1, 2004); thence north along the east City limits of Bellevue (as of September 1, 2004) to the intersection of the most northwesterly point of the City limits of Issaquah (as of September 1, 2004); thence east along the adjoining north City limits of Issaquah (as of September 1, 2004) to its intersection with Interstate 90; thence east along Interstate 90 until the intersection with Renton Road (Renton Road-Issaquah Road) also Highway 900; thence south along said road to a line common to T. 23 N., and T. 24 N., R. 5 E., and thence westerly along said line to the easterly boundary of the City Limits of Renton, (M.V.G. No. 220, July 7, 1964); thence along said City Limits in a northwesterly direction to the shores of Lake Washington to the point of beginning. Also including Maple Valley Golf Course.

(PID320) SOLID WASTE COLLECTION SERVICE in that portion of King County described as follows:

Commencing at the intersection of the south city limits of the City of Seattle and the intersection of said city limits with Lake Washington; thence southerly along the shores of Lake Washington to the City of Renton City limits; thence along the westerly boundary of the city limits of the City of Renton to Renton Avenue; thence northwesterly along the northerly side of Renton Avenue to 76th Avenue South to South 125th Street, thence east to 77th Avenue South; thence north along the east side of 77th Avenue South to South 120th Street; thence along the north side of South 120th Street to 76th Avenue South; thence north on 76th Avenue South (east side only) to 116th Street South; thence west on 116th Street South (no service between 116th Street South and Cornell Avenue); thence north along the eastside of Cornell Avenue to Seattle City Limits; thence easterly along said city limits to the east boundary thereof, adjacent to Lake Ridge Addition; thence northerly along said city limits to South 112th Street extended; thence westerly along said city limits to 68th Avenue South extended; thence northerly along said city limits to Ryan Street extended; thence easterly along said city limits to the point of beginning, from the described territory to dumps in King County.

WASHINGTON UTILITIES AND TRANSPORTATION COMMISSION

Continuation Page

(PID373) SOLID WASTE COLLECTION SERVICE in that portion of King County described as follows: Starting at the intersection of NE 199th Street and 84th Ave. NE; then east on NE 199th Street to its intersection with 90th Ave. NE; then north on 90th Ave. NE to its intersection with NE 200th Street; then west on NE 200th Street to its intersection with 88th Ave. NE; then north on 88th Ave. NE to its intersection with NE 202nd Street; then east on NE 202nd Street to its intersection with 90th Ave. NE; then north on 90th Ave. NE to its intersection with NE 205th Street (also the King-Snohomish County line); then west on NE 205th Street to its intersection with 84th Ave. NE (also the west range line of T26N, R5E); then south on 84th Ave. NE to its intersection with NE 199th Street, the point of beginning.

Also: Starting at the intersection of 84th Ave. NE and NE 180th Street; then east on NE 180th Street to its intersection with 88th Ave. NE; then north on 88th Ave. NE to its intersection with NE 181st Street; then east on NE 181st Street to its intersection with 90th Pl. NE; then north on 90th Pl. NE to its intersection with NE 185th Street; then west on NE 185th Street to its intersection with 88th Ave. NE; then north on 88th Ave. NE to its intersection with 192nd Pl. NE; then west on 192nd Pl. NE to its intersection with 84th Ave. NE (also the west range line of T26N, R5E); then south on 84th Ave. NE to its intersection with NE 180th Street, the point of beginning.

Also: Starting at the intersection of NE Bothell Wy. and 84th Ave. NE; then east on NE Bothell Wy. to its intersection with 91st Ave. NE; then north on 91st Ave. NE to its intersection with NE 172nd Street; then east on NE 172nd Street to its intersection with 92nd Ave. NE; then north on 92nd Ave. NE to its intersection with NE 173rd Street; then east on NE 173rd Street to its intersection with 95th Ave. NE; then north on 95th Ave. NE to 173rd Pl. NE; then west on 173rd Pl. NE to its intersection with 93rd Pl. NE; then north on 93rd Pl. NE to its intersection with NE 175th Street; then west on NE 175th Street to its intersection with 93rd Ave. NE; then north on 93rd Ave. NE to its intersection with NE 176th Street; then east on NE 176th Street to its intersection with 95th Ave. NE; then north on 95th Ave. NE to its intersection with NE 178th Street; then west on NE 178th Street to its intersection with 88th Ave. NE; then north on 88th Ave. NE to its intersection with NE 180th Street; then west on NE 180th Street to its intersection with 84th Ave. NE (also the west range line of T26N, R5E); then south on 84th Ave. NE to its intersection with NE Bothell Wy., the point of beginning.

(PID374) REFUSE COLLECTION SERVICE from commercial accounts or establishments in that portion of King County described as follows: Starting at the intersection of 92nd Ave. NE and 186th Pl. NE; then east on 186th Pl. NE to its intersection with 93rd Pl. NE; then north on 93rd Pl. NE to its intersection with NE 187th Street; then east on NE 187th Street to its intersection with 95th Ave. NE; then south on 95th Ave. NE to its intersection with 186th Pl. NE; then east on 186th Pl. NE to its intersection with 96th Ave. NE; then north on 96th Ave. NE to its intersection with NE 188th Street; then west on NE 188th Street to its intersection with 95th Ave. NE; then north on 95th Ave. NE to its intersection with NE 189th Street; then west on NE 189th Street to its intersection with 93rd Pl. NE; then north on 93rd Pl. NE to its intersection with NE 190th Street; then west on NE 190th Street to its intersection with 92nd Ave. NE; then south on 92nd Ave. NE to its intersection with NE 189th Street; then east on NE 189th Street to its intersection with 93rd Ave. NE; then south on 93rd Ave. NE to its intersection with NE 187th Street; then west on NE 187th Street to its intersection with 92nd Ave. NE; then south on 92nd Ave. NE to its intersection with 186th Pl. NE, the place of beginning.

(PID433) SOLID WASTE COLLECTION SERVICE in that portion of King and Pierce Counties described as follows: Starting at the point where 1st Avenue South intersects with the shore line of Puget

WASHINGTON UTILITIES AND TRANSPORTATION COMMISSION

Continuation Page

Sound; thence south on 1st Avenue South to South 292nd Street projected; thence east on South 292nd Street projected to 8th Avenue South projected; thence north on 8th Avenue South projected to South 288th Street projected; thence east on South 288th Street projected to 12th Avenue South; thence north on 12th Avenue South projected to South 282nd Street projected; thence east on South 282nd Street projected to its intersection with the east city limits of Des Moines; thence northerly, along said city limits to its intersection with S. 272nd Street; thence east along said street to the east city limits of Federal Way; thence south along said city limits to S. 304th Street; thence east on the South side of So. 304th Street extended to the centerline of Sec. 11, T. 21 N., R. 4 E.; thence south on centerline of Sections 11 and 14, T. 21 N., R. 4 E., to Peasley Canyon Road; thence easterly on Peasley Canyon Road to the intersection with W. Valley Hwy S.; thence north along said Avenue to the intersection with Main Street West; thence east along said street to "A" Street S.E. (Auburn-Sumner Highway), thence south on said highway to the King-Pierce County Line; thence west along on said county line and northerly to its intersection with the east quarter section line of Sec. 25, T. 21 N., R. 3 E.; thence south on said quarter section line to south quarter section line of Sec. 25; thence west on south quarter section line to the west quarter section line of Sec. 26, T. 21 N., R. 3 E.; thence north on said quarter section line to the ½ section line of Sec. 26, T. 21 N., R. 3 E.; thence west on said ½ section line to intersection with the west line of Sec. 26, T. 21 N., R. 3 E.; thence north along said section line to northwest corner of Sec. 23, T. 21 N., R. 3 E.; thence east along north line of Sec. 23 to intersection with King-Pierce County Line; thence northwesterly along said county line to the shoreline of Puget Sound; thence northeasterly along said shore line to intersection with 1st Avenue South, the place of beginning.

(PID435) SOLID WASTE COLLECTION SERVICE not requiring the use of a dump truck and excluding biomedical waste, in that portion of King County described as follows: Commencing at the intersection of NE 108th Street and 132nd Ave. NE; thence easterly on NE 108th Street to the Redmond City limits, thence following the Redmond city limits in a southerly, southeasterly and westerly clockwise direction to 132nd. Ave. NE; thence north along 132nd Ave. NE to its intersection with NE 108th Street, the point of beginning.

Also, commencing at the intersection of NE 97th Street and 132nd Ave. NE; thence following the Redmond city limits in a southeasterly and westerly clockwise direction to 132nd Ave. NE, thence north along 132nd Ave. NE to its intersection with NE 97th Street, the point of beginning.

Also, commencing at the intersection of NE 78th Street extended east and 132nd Ave. NE; thence following the Redmond city limits in an easterly, southerly and westerly clockwise direction to 132nd Ave. NE, thence north along 132nd Ave. NE to its intersection with NE 78th Street extended east, the point of beginning.

Also, commencing at the intersection of NE 70th Street and 132nd Ave. NE; thence following the Redmond city limits in an easterly, southerly and westerly clockwise direction to 132nd Ave. NE thence north along 132nd Ave. NE to its intersection with NE 70th Street, the point of beginning.

(PID436) REFUSE COLLECTION SERVICE not requiring the use of a dump truck in that portion of King County described as follows: Starting at the intersection of S.W. 152nd Street extended and Puget Sound; thence east along S.W. 152nd Street to its intersection with Ambaum Blvd. S.W.; thence southerly along Ambaum Blvd. S.W. to its intersection with S. 156th Street; thence east to Des Moines; thence south along Des Moines Way to S.W. 160th Street; thence southwesterly along S.W. 160th Street and

WASHINGTON UTILITIES AND TRANSPORTATION COMMISSION

Continuation Page

Sylvester Rd to its intersection with the north city limits of Normandy Park; thence westerly and northerly along said north city limits to its intersection with 1st Ave. S.; thence south along 1st Ave. S. to its intersection with S. 192nd Street; thence east along S. 192nd Street to its intersection with Pacific Highway S. (International Blvd.); thence north to S. 188th Street; thence east along S. 188th Street to its intersection with the city limits of the City of Sea-Tac and the City of Tukwila; thence southerly and easterly along the south city limits of Tukwila to its intersection with the city limits of the City of Kent as of January 1, 1987; thence southerly and easterly in a counterclockwise direction along the city limits of the City of Kent as of January 1, 1987 to its intersection with State Highway 516 and S.E. Kent Kangley Road; thence southeasterly along State Highway 516/Kent Kangley Road to 116th Ave. S.E.; thence south along 116th Ave. S.E. to its intersection with S. 277th Street extended; thence west along S. 277th Street extended to West Valley Highway; thence south along said Highway to S. Peasley Canyon Road; thence west along S. Peasley Canyon Road; to 59th Ave. S. thence north along 59th Ave. S. to the point where it intersects with 304th Street extended; thence west along 304th Street extended where it intersects with Interstate Hwy I-5; thence north along said Interstate Highway to its intersection with S. 272nd Street; thence west on S. 272nd Street to the city limits of Des Moines; thence south along said city limits to the point where it intersects with S. 282nd Street extended; thence west on S. 282nd extended to 12th Ave. S. extended; thence south on 12th Ave. S. to the point where it intersects with S. 288th Street; thence west on S. 288th Street to its intersection with 8th Ave. S.; thence south on 8th Ave. S. to SW. 292nd Street extended; thence west on S.W. 292nd Street extended to 1st Ave. S.; thence north on 1st Ave. S.; to the shoreline of Puget Sound; thence northerly along the shoreline of Puget Sound to its intersection with S.W. 152nd Street extended, the point of beginning.

(PID437) SOLID WASTE COLLECTION SERVICE in that portion of King County as bounded on the West by Puget Sound; on the East by Lake Washington; on the North by as follows: Commencing at the intersection of E. 145th Street and the shores of Lake Washington, thence west on the south side of E. 145th Street to 5th Ave. N. E., thence north on the west side of 5th Ave. N. E. to E. 175th Street, thence east on the north side of E. 175th Street to 8th Ave. N. E., thence north on 8th Ave. N. E. (but not including 8th Ave. N. E.) to 190th Street, thence north on both sides of 8th Ave. N. E. extended to E. 201st Street, thence east on both sides of E. 201st Street extended to the west side of 11th Ave. N. E. extended, thence north on the west side of 11th Ave. N. E. extended to King-Snohomish County line, thence west on the south side of said line to the shore of Puget Sound; and on the South, by as follows: Commencing at the intersection of the south city limits of Seattle and Lake Washington, then following the city limits of Seattle in a clockwise direction to its intersection with 116th Street South; thence east on 116th Street South to 76th Ave. South; thence south on centerline of 76th Avenue South to South 120th Street centerline; thence east on centerline of South 120th Street to 77th Avenue South centerline; thence South on centerline of 77th Avenue South to South 125th Street centerline; thence west on centerline of South 125th Street to 76th Avenue South centerline; thence south on centerline of 76th Avenue South to Renton Avenue South centerline; thence easterly on centerline of Renton Avenue South to Renton West city limits (as of June 1, 1961); thence southerly along said city limits to the centerline of Hardie Street; thence south along the centerline of said street to South 134th Street centerline; thence westerly on centerline of South 134th Street to 81st Avenue South centerline; thence south on centerline of 81st Avenue South to SW Sunset Boulevard (MLK Junior WY) centerline; thence easterly following said road to Rainier Ave. (PSH-5); thence following Rainier Ave. in a southerly direction to south line of Section 19, T. 23 N., R. 5 E. (S.E. 160th Street); thence east along south line of said Section to the Renton City Limits; thence following the City Limits of Renton in a counter-clockwise direction to the point where it intersects with Maple Valley Highway; thence southeasterly along said highway to the intersection of the

WASHINGTON UTILITIES AND TRANSPORTATION COMMISSION

Continuation Page

east line of the west half of Section 24, T. 23 N., R. 5 E. (172nd Ave. S.E. extended north); thence south along said line extended to the south line of Section 1, T. 22 N., R. 5 E., W.M., (or Southeast 208th Street) thence west along said south line to 148th Ave. S.E.; thence north along 148th Ave S.E to S.E 192nd Street; thence west to 140th Ave. S.E.; north to Petrovitsky Road (S.E. 176th); thence west along Petrovitsky Road to its intersection with Carr Road and 108th Ave. S.E.; thence west along Carr Road to State Hwy 167; thence south along State Hwy 167 to the south line of Section 6, T.22N., R, 5E.; W.M., (or Southeast 208th Street extended); thence following said city limits in a clockwise direction to the northwest corner of said city limits, extended to the west bank of the Duwamish River; thence northerly along the west bank of said River to the north line of the southwest ¼ of Section 25, T. 23 N., R. 4 E. thence east on said northwest line to its intersection with West Valley Rd (State Hwy. 181); thence northerly along West Valley Rd (State Hwy. 181) to the south line of Section 24, T. 23 N., R. 4 E. (South 160th Street extended); thence west on south line of said section to the easterly bank of the Duwamish River; thence northerly along the west bank of said River to the point or intersection with the south line of the northwest (continued) quarter of Section 24, T. 23 N., R. 4 E., W.M.; thence east along the south line of said northwest quarter to the west side of that portion of the city of Renton as annexed by city ordinance No. 1764 lying westerly of the east margin of BNR Company (N.P.RR) main track right of way all being located in the south ½ of the NW ¼ of Section 24, Township 23 North, Range 4 East, thence east from the east side of said portion of City of Renton along the south line of the northwest (continued) quarter of Section 24, T. 23 N., R. 4 E., W.M. to the east side of the Charles Monster Road; thence northerly along the along the easterly side of said road to the Beacon Coal Mine road; thence northerly along the along the easterly side of said road to the South 129th Street extended; thence easterly on South 129th Street to State Highway 900 (Martin Luther King Jr. Way) centerline; thence northwesterly along said boulevard to South 120th Street; thence West along South 120th Street extended to 51st Avenue South; thence North along extension of 51st Avenue South to Empire Way South Centerline; thence northwesterly on intersection of Empire Way South to Ryan Street centerline extended thence West along Ryan Street extension to extension of 33rd Avenue South; thence North along extension of 33rd Avenue South to extension of South Trenton Street; thence West along extension of South Trenton Street to East Marginal Way; thence Northwesterly along East Marginal Way to extension of South Kenyon Street; thence West along extension of South Kenyon Street to extension of 12th Avenue South; thence South along extension of 12th Avenue South to the West bank of Duwamish Waterway thence south along the West bank of the Duwamish Waterway to a point of intersection with Pacific Highway South (International Blvd) .; thence in a southerly direction along Pacific Highway South (International Blvd) to its intersection with S. 128 Street extended; thence west of S. 128 Street extended to its intersection with Military Road also the northeast point city limits of the City of Sea-Tac; thence south along Military Road and said city limits to its intersection with Pacific Highway south (International Blvd); thence southerly along Pacific Highway S. to the intersection of Pacific Highway S. and 160th Street; thence in an easterly and southerly direction along the city limits of the City of Sea-Tac to a point where the City Limit intersects for the second time the W. R/W line of Interstate Hwy #5; thence south on said W. R/W line to S. 176th Street; thence west on S. 176th Street (north side only) to Military Road; thence south on Military Road (west side only) to S. 188th Street; thence west on S. 188th Street (north side only) to PSH-1; thence south on PSH-1 (west side only) to S. 192nd Street; thence west on S. 192nd Street (north side only) to 1st Ave. S.; thence north on 1st Ave. South to a point where it intersects with the northerly city limits of Normandy Park at a point where 1st Ave. S. intersects with S.W. 162th Street; thence in a westerly direction along the north city limit line of Normandy Park to a point where said city limit line intersects with Sylvester Rd.; thence in a northeasterly direction on Sylvester Road serving the southeasterly side thereof to S. W. 160th Street; thence east on S. W. 160th

WM000006

WASHINGTON UTILITIES AND TRANSPORTATION COMMISSION

Continuation Page

and So. 160th Streets serving the south side thereof to Des Moines Way; thence north on Des Moines Way serving the east side thereof to S. 156th Street; thence west on S. 156th and S. W. 156th Street serving the north side thereof to Ambaum Blvd.; thence north on Ambaum Blvd. serving the east side thereof to S. W. 152nd Street; thence west on S.W. 152nd Street to Puget Sound.

EXCEPTION: The following paragraph is excluded from the above SOLID WASTE COLLECTION SERVICE. In that portion of King County described as follows: Commencing at the intersection of Military Road S. and Highway 516 (Kent-Des Moines Road); thence following the city limits of Kent in a clockwise direction easterly, southerly, westerly, and northerly to its intersection with Military Road S. at S. 240th Street; thence north along Military Road S. to its intersection with Highway 516 (Kent-Des Moines Road), the point of beginning.

(PID438) SOLID WASTE COLLECTION SERVICE in that portion of King County described as follows: Starting at the intersection of the Everett-Bothell County Highway and the Snohomish-King County line; thence east on Snohomish-King County line to its intersection with east line of T. 26 N., R. 7 E.; thence south on said line to its intersection with the south line of T. 25N., R. 7 E.; thence west on said line to the east line of T. 25N., R. 6 E.; thence north on said line to the S.E. corner of the N.E. ¼ of the N.E. ¼ of Section 36, T. 25 N., R. 6 E.; thence west on a line projected from said corner to the east shore of Lake Sammamish, thence following said Lake shore generally in northwesterly and southerly (counter-clockwise) direction to the point where the southeastern city limits of Redmond intersect the western shore of Lake Sammamish; thence following the city limits of Redmond as of January 3, 1978, in a clockwise direction to the point where the Sammamish River (waterway) intersects with the north city limits of Redmond; thence following the east bank of said river in a generally northerly direction to its intersection with N.E. 145th Street extended (at this point a short section of PSH-2 is one and the same as N.E. 145th Street); thence west on N.E. 145th Street extended (no service to be rendered on either side of N.E. 145th Street) to its intersection with 104th Avenue N.E.; thence northerly on 104th N.E. (rendering service on both sides of 104th Avenue N.E.) to its intersection with 105th Ave. NE; thence northerly to the north line of the south west quarter of Section 8, T26N, R5E; thence west along said north line to the west line of said section; thence south along the west line of said section to the south city limits of Bothell; thence following the city limits of Bothell, clockwise, to its intersection with the Everett-Bothell County Highway; thence north to place of beginning.

(PID439) REFUSE COLLECTION SERVICE, not requiring the use of a dump truck, in that portion of King County described as follows: Starting at the northeast corner of T26N, R8E; thence south along the east line of R8E to the south line of T22 N; thence west along said south line to the west line of R. 8 E.; thence north along said west line to the southeast corner of Section 12 T22N, R7E.; thence west along the south line of said section extended to the northeast corner of Section 19, T22N, R7.E; thence south along the east line of said section to its intersection with the Green River; thence westerly along the banks of said river to the northeast City limits of Auburn within Section 8, T21N, R5E; thence south along the west line of said Section 8 extended to the southeast corner of Section 31, T21N, R5E, also the south boundary of King County; thence west along the south line of said section 31 to its intersection with A Street SE; thence north along said street to its intersection with West Main Street; thence west along said street to West Valley Highway; thence north along West Valley Highway to South 277th Street; thence east along said street extended to 116th Ave. SE; thence north along 116th Ave. SE. to SE. 258th Street extended; thence east on said street extended to 117th PL SE extended; thence north along 117th PL. SE. extended to SE 256th Street SE; thence west along said street to 116th Ave. SE; thence north along said street to SE

WASHINGTON UTILITIES AND TRANSPORTATION COMMISSION

Continuation Page

208th Street. SE; thence east along said street to the point of its intersection with 172nd Ave. SE extended; thence north along said Avenue to Renton Maple Valley Road; thence westerly along said road to its intersection with the City limits of Renton as of September 1, 1959; thence south along said City limits to the north line of Section 20, T23N, R5E, also city limits of Renton as of February 28, 1961; thence in a clockwise direction along said city limits to the south line of Section 20, T23N, R5E; thence west along said south line to its intersection with State Highway 167; thence north along said State Highway to SW Sunset Boulevard; thence west along said boulevard to 81st (Oakdale) Ave. SW; thence north to the City limits of Renton as of August 4, 1931; thence in a counter-clockwise direction along said City limits of Renton to Renton Avenue South; thence westerly along Renton Avenue S. to 76th Ave. South; thence north to S. 125th Street extended; thence east on S. 125th Street extended to 77th Ave. S. extended thence north along 77th Ave. S. to S. 120th Street; thence west on said street to 76th Ave. South; thence north along said Avenue to S. 116th Street; thence west along S. 116th Street to its intersection with the City limits of Seattle; thence in a clockwise direction along said city limits to its intersection with the west shoreline of Lake Washington; thence in a counter-clockwise direction along the shoreline of Lake Washington to the point where it intersects with the northwest city limits of Renton; thence east and southerly along the city limits of Renton (M.V.G. No.220, 7-7-64) to a line common to T23N, and T24N. R5E; thence easterly along said line to Renton Road (Renton-Issaquah Road); thence north along said road to the north line of Section 29, T24N, R6E; thence east along said section line extended to NW Gilman Boulevard; thence easterly along NW Gilman Boulevard to 1st Ave. NW; thence north along said avenue to E. Lake Sammamish PKWY; thence northerly along said PKWY to the point where it intersects with the north line of SW ¼ of Section 16, T24N, R6E; thence west to the shoreline of Lake Sammamish; thence in a clockwise direction along the shoreline of Lake Sammamish to the point where it intersects with NW 4th Street extended; thence east along said street to the east line of Section 36, T25N, R6E; thence south along said east line to the northwest corner of Section 6 T24N, R7E; thence east along the north line of said section extended to the southwest corner of Section 31, T25N, R8E; thence north along the west line of said section 31 extended to the northwest corner of Section 6, T26N, R8E also the King and Snohomish County line; thence east along said county line to the northeast corner of T26N, R8E, the point of beginning.

(PID440) ALSO in that portion of King county described as follows: Starting at the point where East Marginal Way S. intersects with the south line of Section 28 T24N, R4E; thence southerly along East Marginal Way S. to S. Trenton Street extended, also the city limits of Tukwila; thence east and south along the city limits of Tukwila to the point where it intersects with S. Ryan Street extended; thence east on said street to Empire Way S (State Highway 900); thence southerly along said highway to South 129th Street; thence westerly along said street to the east side city limits of Tukwila; thence southerly along said city limits to the point where it connects with Beacon-Coal Mine Road; thence southerly along the east side of said road to Charles Monster Road; thence continuing southerly along Charles Monster Road projected to the south line of the northwest quarter of Section 24, T23N, R4E, W.M.; thence southerly along the easterly bank of Duwamish River to the south line of Section 24, T23N, R4E. (South 160th Street extended); thence east on south line of said section to West Valley Highway (State Highway 181); thence south along said highway to the north line of the southwest ¼ of Section 25, T23N, R4E; thence west on said north line to the west bank of the Duwamish River; thence southerly along said River to South 180th Street (SW 43rd Street); thence east along said street to the east side of current city limits of Tukwila; thence in a clockwise direction along said city limits to the point where it intersects with the Pacific Highway South (International Blvd.); thence northerly along said Highway to the point where it intersects with the Duwamish Waterway; thence northerly along the west bank of the Duwamish

WASHINGTON UTILITIES AND TRANSPORTATION COMMISSION

Continuation Page

Waterway to the point where it intersects with 12th Avenue S. extended; thence north on extended 12th Avenue S. to the south line of Section 29 T24N, R4E; thence east along said section line extended to its intersection with East Marginal S., the place of beginning.

(PID441) ALSO in that portion of King County described as follows: Starting at the point where SE. 208th Street intersects with 116th Ave. SE.; thence south along 116th Ave. SE to its intersection with SE. 228th PL also the city limits of the City of Kent as of January 1, 1987; thence westerly, southerly and northerly (clockwise direction) to its intersection with SE. 208th Street; thence east along said street to the point where it intersects with 116th Ave. SE., the point of beginning.

(PID442) ALSO in that portion of King County described as follows: Starting at the point where 116th Street SE. intersect with SE. 240th Street, also the city limits of the City of Kent as of January 1, 1987; thence south along 116th Street SE. to its intersection with the city limits of the City of Kent as of January 1, 1987; thence westerly, southerly, northerly and easterly (clockwise) direction to its intersection with 116th Street SE, the point of beginning.

(PID443) REFUSE COLLECTION SERVICE, not requiring the use of a dump truck, (local cartage) in Vashon and Maury Islands.

(PID451) SOLID WASTE COLLECTION SERVICE consisting of reclaimed lumber, brick and other cast off materials, from premises where construction or repair job are being or have been conducted, or where structures are being razed in the following: Maury, Mercer, and Vashon Islands; and in that portion of King county described as follows: Starting at the northwest corner of T26N, R8E; thence east along the north line of said T26N, also the King and Snohomish County Line to its intersection with King and Chelan County line; thence south along said county line to its intersection with King and Kittitas County Line; thence southwesterly along the King and Kittitas County line to the south line of Section 33, T23N, R11E; thence west to the west line of the East 1/2 of Section 33, T23N, R11E; thence north along said west line to the north line of said Section 33, thence east on said north line to the southeast corner of Section 28, T23N, R11E; thence north along the east line of said section to the north east corner of said section; thence west along the north line of said section to the northwest corner of Section 30, T23N, R11E; thence south along the west line of said section extended to the southwest corner of the NW 1/4 of Section 19, T22N, R11E; thence west along the south line of said NW 1/4 to the southeast corner of the NE1/4 of said Section 19; thence north along the east line of said section extended to the northwest corner of Section 8, T22N, R11E; thence east along the north line of said section to its intersection with King County line; thence southerly and westerly along said county line to its intersection with the west line of T19N, R8E; thence north along said west line extended to the southeast corner of Section 13, T22N, R7E; thence west along the south line of said section to the northeast corner of Section 19, T22N, R7E; thence south along the east line of said section to its intersection with the Green River banks; thence westerly along the Green River banks to the northeast City limits of Auburn within Section 8, T21N, R5E; thence south along the west line of said Section 8, extended to the boundary line of King County; thence west along said boundary line to its intersection with the southwest corner of Section 31, T21N, R5E; thence north along the west line of said section to its intersection with Main Street West; thence west along said street to the intersection with West Valley Hwy N. ; thence South along said highway to South Peasley Canyon Road; thence west along said road to its intersection with the centerline of Section 14, T21N, R4E; thence north along said centerline of said section extended to the north line of Section 11, T21N, R4E; thence west along the north line of said section extended to the city limits of Federal Way; thence

WASHINGTON UTILITIES AND TRANSPORTATION COMMISSION

Continuation Page

north in a counter-clockwise direction along said city limits to its intersection with South 282nd Street projected east; thence west along said street to 12th Avenue South projected north; thence south along 12th Avenue South to its intersection with South 288th Street projected; thence west along said street to 8th Avenue South projected; thence south along said 8th Avenue to South 292nd Street projected; thence west along said 292nd Street to 1st Avenue South; thence north on 1st Avenue South extended to the shoreline of Puget Sound; thence northerly along said shoreline to S.W. 152nd Street extended; thence east along said street to Ambaum Blvd. S.W. ; thence south along Ambaum Blvd. to S. 156th Street; thence east along said street to Des Moines Way; thence south along the Des Moines Way to S. 160th Street; thence west on said street to Sylvester Road S.W.; thence south along Sylvester Road to the city limits of Normandy Park ; thence east in a clockwise direction along the city limits of Normandy Park to its intersection with S. 192nd Street; thence east along S. 192nd Street to Pacific Highway S. also the International Boulevard; thence north on said boulevard to S. 188th Street; thence east along S. 188th Street to Military Road; thence from Military to the point where it intersects with the city limits of Tukwila; thence northerly along the city limits of Tukwila to the point where it intersects with S. 128th Street; thence east along said street to Pacific Highway South (International Blvd.); thence north along said highway to the banks of Duwamish Waterway; thence northerly along the banks of said waterway to 12th Avenue South extended; thence north along said 12th Ave.; to S. Kenyon Street extended; thence east on extended S. Kenyon Street to East Marginal Way; thence south along East Marginal Way to its intersection with the extension of South Trenton Street; thence east on said street to the extension of 33rd Avenue South; thence south along said avenue to the extension of Ryan Street; thence east on Ryan street to Empire Way South; thence south on Empire Way South to the extension of 51st Avenue South; thence south on said avenue to South 120th Street; thence east on said street to SW Sunset Boulevard (MLK Junior WY); thence south along said boulevard to its intersection with S. 129th Street; thence west on South 129th Street to the city limits of Tukwila; thence southerly along said city limits to the point where it intersects with Beacon-Coal Mine Road; thence southerly along said road to Charles Monster Road; thence south along Charles Monster Road to the point where it intersects with the south line of the Northwest quarter of Section 24, T23N, R4E; thence west along that portion of city limits as annexed by City of Renton, city ordinance No. 1764 to the banks of the Duwamish River; thence southerly along the banks of said river to the point where it intersects with the south line of Section 24, T23N, R4E; thence east to the State HWY 181; thence south along said highway to the north line of the Southwest ¼ of Section 25, T23N, R4E; thence west on the north line of said Section to the west bank of the Duwamish River; thence southerly along the banks of said river to S. 180th Street; thence east along said street to the city limits of Kent as of January 1, 1987; thence southerly in a counter-clockwise direction along the city limits of Kent to the north line of Section 7, T22N, R5E; thence west along the north line of said section extended to the southeast corner of the west half of Section 1, T.22N, 5E; thence north along the east line of the west half of said section to the Maple Valley Highway; thence northwesterly along the Maple Valley Highway to the city limits of Renton; thence south in a clockwise direction along said city limits to the southeast corner of Section 20, T23N, R5E. (S.E. 160th Street); thence east along the south line of said section to the State Highway 167 (Rainier Ave.); thence north along said highway to its intersection with Southwest Sunset Boulevard; thence westerly along said boulevard to 81st Avenue South; thence north to 134th Street; thence east on 134th Street to Hardie Street; thence north to the city limits of Renton (as of June 1, 1961); thence north along said city limits to Renton Avenue South; thence northwesterly along Renton Avenue South to 76th Avenue South; thence north on 76th Ave. S. to S. 125th Street; thence east to 77th Ave. S.; thence north along 77th Ave. S. to S. 120th Street; thence west on said street to 76th Ave. S.; thence north on said street to 116th Street S.; thence west on said street to its intersection with the south City limits of Seattle; thence north in a counter-clockwise direction along

WASHINGTON UTILITIES AND TRANSPORTATION COMMISSION

Continuation Page

the city limits of Seattle to its intersection with Lake Washington; thence in a counter-clockwise direction along the shoreline of Lake Washington to the northwest city limit of Renton; thence southeasterly along the City limits of Renton to the point where the city limits of Renton intersects with the south line of Section 33, T24N, R5E; thence east along the south line of said section extended to its intersection with Renton Road (Renton Road-Issaquah Road) also Highway 900; thence north along said Road to its intersection with Interstate 90(Sunset Hwy); thence northwesterly along said Interstate to the shoreline of Lake Washington; thence northerly in a counter-clockwise direction along the shoreline of Lake Washington to its intersection with 145th Street; thence west along said street to its intersection with 5th Ave. N.E.; thence north along on 5th Ave. N.E. to N.E. 175th Street; thence east on said street to 8th Ave. N.E. thence north on said street extended to N.E. 201st Street extended; thence east on said street to 11th Ave. N.E. extended; thence north to the King-Snohomish Boundary (N.E. 205th Street); thence east along said boundary to the north east corner of Section 1, T26N, R4E; thence south along the east line of said section to NE 199th Street; thence east on said street to its intersection with 90th Ave NE; thence north on 90th Ave. NE to its intersection with NE 200th Street; thence west on NE 200th Street to its intersection 88th Ave. NE; thence north on 88th Ave. NE to its intersection with NE 202nd Street; thence east on NE 202nd Street to its intersection with 90th Ave. NE; thence north on 90th Ave. NE to its intersection with NE 205th Street (also the King-Snohomish County line); thence east on said county line to State Highway 527 (Everett-Bothell County Highway); thence southerly in a counter-clockwise direction said highway to its intersection with the city limits of Bothell as of January 3, 1978; thence following the city limits of Bothell in a counter-clockwise direction to the southwest corner of Section 17, T26N, R5E; thence north along the west line of said section to the north line of the southwest quarter of Section 8, T26N, R5E; thence east along the north line of said section to 102nd Ave. NE; thence south along 102nd Ave. NE to its intersection with 105th Ave. NE; thence south along 105th Ave. NE to its intersection with 104th Ave. NE; thence south to NE 145th Street; thence east on said street to its intersection with the east bank of Sammamish River(waterway); thence south along said River to its intersection with the city limits of Redmond; thence in a counter-clockwise direction along the city limits of Redmond as of January 3, 1978 to its intersection with the west shoreline of Lake Sammamish; thence northerly and southerly in a clockwise direction along the shore line of Lake Sammamish to the point where the east shoreline of Lake Sammamish intersects with the south line of NE ¼ of NW ¼ of Section 32, T25N, R6E; thence east along said south line extended to the east line of Section 36, T25N, R6E; thence south to the southwest corner of Section 31, T25N, R7E; thence east on along the south line of said section extended to the southeast corner of T25N, R7E; thence north along the east line of said township to the Snohomish-King County line; thence east along said county line to its intersection with King-Chelan County line the place of beginning.

EXCEPTION: THE FOLLOWING PARAGRAPH IS EXCLUDED FROM THE ABOVE GARBAGE AND REFUSE COLLECTION SERVICE.

Starting at the intersection of NE Bothell Way. and 84th Ave. NE; then east on NE Bothell Wy. to its intersection with 91st Ave. NE; then north on 91st Ave. NE to its intersection with NE 172nd Street; then east on NE 172nd Street to its intersection with 92nd Ave. NE; then north on 92nd Ave. NE to its intersection with NE 173rd Street; then east on NE 173rd Street to its intersection with 95th Ave. NE; then north on 95th Ave NE to 173rd Pl. NE; then west on 173rd Pl. NE to its intersection with 93rd Pl. NE; then north on 93rd Pl. NE to its intersection with NE 175th Street; then west on NE 175th Street to its intersection with 93rd Ave. NE; then north on 93rd Ave. NE to its intersection with NE 176th Street; then east on NE 176th Street to its intersection with 95th Ave. NE; then north on 95th Ave. NE to its

WASHINGTON UTILITIES AND TRANSPORTATION COMMISSION

Continuation Page

intersection with NE 178th Street; then west on NE. 178th Street to its intersection with 88th Ave. NE; then north on 88th Ave. NE to its intersection with NE 180th Street; then west on NE 180th Street to its intersection with 84th Ave. NE (also the west range line of T26N, R5E); then south on 84th Ave. NE to its intersection with NE Bothell Wy., the point of beginning.

(PID452) REFUSE COLLECTION SERVICE, not requiring the use of a dump truck,(local cartage) in that portion of King County described as follows: Beginning at the intersection of King-Snohomish County line and 15th Ave. NE; thence south along 15th Ave. NE to its intersection with NE 175th Street; thence west along NE 175th Street to 8th Ave. N.E.; thence north along said Avenue extended to E. 201st Street; thence east on E. 201st Street extended to the West side of 11th Ave. N.E. extended; thence north on the west side of 11th Ave. N.E. extended to King-Snohomish County line; thence east on the said County line to 15th Ave. N.E. the point of beginning.

(PID453) ALSO: Beginning at the intersection of NE Bothell Wy. and 91st Ave. NE; thence north on 91st Ave. to its intersection with 172nd Street; then east on NE 172nd Street to its intersection with 92nd Ave. NE; then north on 92nd Ave. NE to its intersection with NE 173rd Street; then east on NE 173rd Street to its intersection with 95th Ave. NE; then north on 95th Ave NE to NE 175th Street; thence west on NE 175th Street to its intersection with 93rd Pl. NE (also city limits of Bothell); then north on 93rd Pl. NE to its intersection with NE 176th Street; thence east on NE 176th Street to its intersection with 95th Ave. NE; thence north on 95th Ave. NE to its intersection with NE 178th Street; then west on NE. 178th Street to its intersection with 88th Ave. NE; then north on 88th Ave. NE to its intersection with the city limits of Bothell (also Dawson Street extended); thence in a counter-clockwise direction along the city limits of Bothell to its intersection with NE 190th Ave.; thence east on NE 190th Ave. to 92nd Ave. NE; thence north along said avenue to NE 192nd PL; thence west on NE 192nd PL.; to 88th Ave. NE; thence north on 88th Ave. N.E. to its intersection with the city limits of Bothell; thence east on said city limits to 92nd Ave. NE extended; thence north on 92nd Ave. NE extended to NE 200th Street extended; thence east on said extended street to NE Bothell Wy.; thence in a clock wise direction along the NE Bothell Wy. to its intersection with 91st Ave, NE, the point of beginning.

(PID454) ALSO: In that portion of King County described as follows: Starting at the southwest corner of Section 8, T26N, R5E; thence east on the south line of said section to 1044th Ave. NE; thence north along 104th Ave. NE to its intersection with 105th Ave. NE; thence northerly along 105th Ave. NE to the north line of south west quarter of Section 8, T26N, R5E; thence west along said north line to the west line of Section 8, T26N, R5E; thence south along said west line to the south west corner of said section the point of beginning

(PID456) SOLID WASTE COLLECTION SERVICE in that portion of Snohomish County described as follows: Commencing at a point where a north-south line tangent to the west shoreline of Ballinger Lake intersects with the Snohomish-King County line; thence north on said line to its intersection with (Bradley Road) 236th Street S.W. extended; thence west on (Bradley Road) 236th Street S.W. to 76th Ave. W.; thence north on 76th Ave. W. (but not including structures thereon), to U. S. Highway 99; thence north on U. S. Highway 99 (but not including structures thereon) to 200 Street S. W.; thence north on the east side of U.S. Highway 99 to a point 100 feet north of 148 Street S.W.; thence west on this line to Puget Sound; Following Puget Sound northerly to the point where the north city limits of Mukilteo meets Possession Sound; thence easterly and southerly following Mukilteo City limits as of July 1, 1961, to the south boundary of Section 3, T. 28 N., R. 4 E. W. M.; thence east to 40 Ave. W. extended; thence south to

WASHINGTON UTILITIES AND TRANSPORTATION COMMISSION

Continuation Page

boundary of Paine Field; following the north boundary of Paine Field to the east boundary of Paine Field; thence south to a point 100 feet north of 90 Street S. W.; thence east on this line to 12 Ave. W. extended (west boundary of Section 13, T. 28 N., R. 4 E.); thence south on 12 Ave. W. extended to 100 Street S. W.; thence east on 100 Street S. W. (both sides) to Holly Drive; thence south on 9 Ave. W. (but not including 9 Ave. W.) to intersection of U.S. Highway 99 and Broadway Cutoff; thence east on Broadway Cutoff to 8 Ave. W. (north-south line bisecting the western ½ of Section 24, T. 28 N., R. 4 E.); thence south on said line to Stockshow Road (112 Street S. W.); thence east on the south side of Stockshow Road to Pacific Northwest Traction right-of-way; thence north on the east side of the right-of-way to Broadway Cutoff; thence north on the Broadway Cutoff and Broadway to the south Everett City limits (as of July 1, 1961); thence following the east and north city limits of Everett (as of July 1, 1961) to Puget Sound; thence northerly along Puget Sound to the point where it intersects with the Snohomish-Island County line; thence northerly along said county line to the shoreline of Skagit Bay; thence north along said shoreline to the Snohomish-Skagit County line; thence east along said county line to the east line boundary of Snohomish County; thence south along the east boundary of Snohomish County to the King-Snohomish County line; thence west on said county line to the point of beginning.

(PID457) GARBAGE COLLECTION SERVICE on Camano Island, Island County.

(PID458) REFUSE COLLECTION SERVICE, not requiring the use of a dump truck, (local cartage) in that portion of Snohomish County described as follows: Starting at the northeast corner of Section 28, T28N, R8E; thence west along the north line of said section extended to a point 500 feet west of the N. E. corner of Sec. 25, T28 N., R. 6 E.; thence south to the south line of said section; thence west to the N. W. corner of Sec. 35, T. 28 N., R. 6 E.; thence south on the west line of said section extended to 164 Street; thence east to Highway 202; thence southwesterly along said highway to the Snohomish River, thence southeasterly along said river and the Snoqualmie River extended to the point 100 feet north of 228 Street; thence east to the east line of Section 28, T27N., R8E; thence north along said west line extended to the northeast corner of Section 28, T28N, R8E, the point of beginning.

(PID459) REFUSE COLLECTION SERVICE, not requiring the use of a dump truck, (local cartage) in that portion of Snohomish County described as follows: Commencing at a point where a north-south line tangent to the west shoreline of Ballinger Lake intersects with the Snohomish-King County line; thence north on said line to its intersection with (Bradley Road) 236th Street S.W. extended; thence west on (Bradley Road) 236th Street S.W. to 76th Ave. W.; thence north on 76th Ave. W. (but not including structures thereon), to U. S. Highway 99; thence north on U. S. Highway 99 (but not including structures thereon) to 200 Street S. W.; thence north on the east side of U.S. Highway 99 to a point 100 feet north of 148 Street S.W.; thence west on this line to Puget Sound; thence southerly along the shoreline of Puget Sound to the Snohomish-King County line; thence east along said county line to the point of beginning.

(PID460) REFUSE COLLECTION SERVICE, not requiring the use of a dump truck, (local cartage) in that portion of Snohomish County described as follows: Starting at the point where the north city limits of Mukilteo meets Possession Sound; thence easterly and southerly following Mukilteo City limits as of July 1, 1961, to the south boundary of Section 3, T. 28 N., R. 4 E. W. M.; thence east to 40 Ave. W. extended; thence south to boundary of Paine Field; following the north boundary of Paine Field to the east boundary of Paine Field; thence south to a point 100 feet north of 90 Street S. W.; thence east on this line to 12 Ave. W. extended (west boundary of Section 13, T. 28 N., R. 4 E.); thence south on 12 Ave. W. extended to 100 Street S. W.; thence east on 100 Street S. W. (both sides) to Holly Drive; thence south on

WASHINGTON UTILITIES AND TRANSPORTATION COMMISSION

Continuation Page

9 Ave. W. (but not including 9 Ave. W.) to intersection of U.S. Highway 99 and Broadway Cutoff; thence east on Broadway Cutoff to 8 Ave. W. (north-south line bisecting the western ½ of Section 24, T. 28 N., R. 4 E.); thence south on said line to Stockshow Road (112 Street S. W.); thence east on the south side of Stockshow Road to Pacific Northwest Traction right-of-way; thence north on the east side of the right-of-way to Broadway Cutoff; thence north on the Broadway Cutoff and Broadway to the south Everett City limits (as of July 1, 1961); thence following the east and north city limits of Everett (as of July 1, 1961) to Puget Sound; thence south along the shoreline of Puget Sound to the point of beginning.

(PID461) ALSO, in the Jetty Island and (PID462) ALSO, in Hat Island (Gedney Island)

(PID463) SOLID WASTE COLLECTION SERVICE consisting of reclaimed lumber, brick and other cast off materials, where construction or repair jobs are being or have been conducted, or where structures are being razed from premises in that portion of Snohomish County described as follows: Starting at the northeast corner of Section 25, T28 N, R8 E; thence west on the north line of said section extended to a point 500 feet west of the N. E. corner of Sec. 25, T28 N., R. 6 E.; thence south to the south line of said section; thence west to the N. W. corner of Sec. 35, T. 28 N., R. 6 E.; thence south on the west line of said section extended to 164 Street; thence east to Highway 202; thence southwesterly along said highway to the Snohomish River, thence southeasterly along said river and the Snoqualmie River extended to the point 100 feet north of 228 Street, thence east to the west line of T27N., R9E; thence north along said west line extended to the northeast corner of Section 25, T28N, R8E, the point of beginning.

(PID464) ALSO: In that portion of Snohomish County described as follows: Commencing at a point where a north-south line tangent to the west shoreline of Ballinger Lake intersects with the Snohomish-King County line; thence north on said line to its intersection with (Bradley Road) 236th Street S.W. extended; thence west on (Bradley Road) 236th Street S.W. to 76th Ave. W.; thence north on 76th Ave. W. to U. S. Highway 99; thence north on U. S. Highway 99 to 200 Street S. W.; thence north on the east side of U.S. Highway 99 to a point 100 feet north of 148 Street S.W.; thence west on this line to Puget Sound; thence southerly along the shoreline of Puget Sound to its intersection with the Snohomish-King County line; thence east along said county line to the point of beginning.

(PID465) ALSO: In those Islands adjacent to the shores within Snohomish County and in that portion of Snohomish County described as follows: Starting at the point where the north city limits of Mukilteo meets Possession Sound; thence easterly and southerly following Mukilteo City limits as of July 1, 1961, to the south boundary of Section 3, T. 28 N., R. 4 E. W. M.; thence east to 40 Ave. W. extended; thence south to the boundary of Paine Field; thence following the north boundary of Paine Field to the east boundary of Paine Field; thence south to a point 100 feet north of 90 Street S. W.; thence east on this line to 12 Ave. W. extended (west boundary of Section 13, T. 28 N., R. 4 E.); thence south on 12 Ave. W. extended to 100 Street S. W.; thence east on 100 Street S. W. (both sides) to Holly Drive; thence south on 9 Ave. W. (but not including 9 Ave. W.) to intersection of U.S. Highway 99 and Broadway Cutoff; thence east on Broadway Cutoff to 8 Ave. W. (north-south line bisecting the western ½ of Section 24, T. 28 N., R. 4 E.); thence south on said line to Stockshow Road (112 Street S. W.); thence east on the south side of Stockshow Road to Pacific Northwest Traction right-of-way; thence north on the east side of the right-of-way to Broadway Cutoff; thence north on the Broadway Cutoff and Broadway to the south Everett City limits (as of July 1, 1961); thence following the east and north city limits of Everett (as of July 1, 1961) to Puget Sound; thence south along the shoreline of Puget Sound to the point of beginning.

WASHINGTON UTILITIES AND TRANSPORTATION COMMISSION

Continuation Page

(PID466) REFUSE COLLECTION SERVICE, not requiring the use of a dump truck, (local cartage) in that portion of Whidbey Island, in Island County described as follows: Starting at the northwest corner of Section 19, T. 30 N., R. 2 E.; thence east along north line of said Section 19 extended to the shoreline of Holmes Harbor; thence southerly and northerly along said shoreline to the north line of Section 23, T30N, R2E; thence east to the eastern shoreline of Whidbey Island; thence southerly, westerly and northerly along the southern shoreline of said island to its intersection with the east line of R1E; thence north on said east line to the shoreline of said island thence northerly along the shoreline to its intersection with the west line of Section 19, T30N, R2E; thence north on said west line to the northwest corner of Section 19, T30N, R2E, the point of beginning.

(PID467) REFUSE COLLECTION SERVICE, not requiring the use of a dump truck, (local cartage) on Bainbridge Island, and in those portion of Kitsap County described as follows:

(PID468) In the City of Bremerton, (PID469) In the City of Paulsbo, and (PID470) on Blake Island.

(PID471) SOLID WASTE COLLECTION SERVICE, consisting of reclaimed lumber, brick and other cast off materials, from premises on Bainbridge Island where construction or repair jobs are being or have been conducted, or where structures are being razed.

(PID472) ALSO, in the City of Bremerton, (PID473) ALSO in Paulsbo, and (PID474) ALSO on Blake Island.

(PID475) REFUSE COLLECTION SERVICE, not requiring the use of a dump truck, (local cartage) in that portion of Mason County described as follows: Beginning at the northeast corner of Section 4, T23N, R1W; thence south along the east line of said section also the Mason-Kitsap County line to the south line of T22N, R1W; thence west along said south line to the southwest corner of Section 31, T22N, R1W; thence north on the west line of T22N, R1W to the southeast corner of Section 36, T23N, R2W; thence west on the south line of said corner extended to the southwest corner of Section 34, T23N, R2W; thence north along the west line of said section extended to the Mason-Kitsap County line; thence east along said county line to the point of beginning.

(PID476) SOLID WASTE COLLECTION SERVICE In all Skagit County (Excluding: Service in the Cities of Mount Vernon, Burlington, Sedro Woolley and Anacortes is limited to "drop-off box" service only; excluding Guemes and Sinclair Island; and excluding the Town of Concrete, Skagit County, Washington, using as a boundary the corporate limits as of March 15, 1965).

(PID477) REFUSE COLLECTION SERVICE, not requiring the use of a dump truck, (local cartage) in that portion of Pierce County described as follows: Beginning at the point where the southwest corner of Section 32, T21N, R4E meets the Pierce-King County line; thence east and southerly along the Pierce-King County line to its intersection with the south line of Section 36, T20N, R6E; thence west on the south line of said section to the west line R6E; thence south along said line to the southeast corner of Section 12, T19N, R5E; thence west along south line of said Section 12 extended to the west line of R3E; thence north along said line to the north line of T19N; thence west along said line to the west line of R2E; thence north along said line to the southeast corner of Section 13, T20N, R1E; thence west along the south line of said Section 13 extended to the west line of R1E; thence north along said line to the south line of T21N; thence west along said line to the southwest corner of Section 34, T21N, R1W; thence

WASHINGTON UTILITIES AND TRANSPORTATION COMMISSION

Continuation Page

north along the west line of said Section 34 extended to the north line of T21N; thence west on said north line to the Pierce-Mason County line; thence north along on said county line to the point where it intersects with the northwest corner of Section 15, T22N, R1W and Pierce-Kitsap County line; thence east along on said county line to Pierce-King County line; thence south and easterly along said county line to its intersection with the south line of Section 14, T21N, R3E; thence west on south line of said section to the northwest corner of Section 23, T21N, R3E; thence south on the west line of said section extended to the south line of NW ¼ of Section 26, T21N, R3E; thence east on said south line to the south east corner of SW ¼ of NW ¼ of said section; thence south along the east line of NW ¼ of SW ¼ of said section to the southeast corner of NW ¼ of SW ¼ thence east on the south line of said NW ¼ extended to the west line of E ½ of SE ¼; thence north on the west line of said E ½ to Pierce-King County line; thence southeasterly along said county line to the southwest corner of Section 32, T21N, R4E, the point of beginning

(PID478) SOLID WASTE COLLECTION SERVICE, consisting of reclaimed lumber, brick and other cast off materials, from premises in Pierce County where construction or repair jobs are being or have been conducted, or where structures are being razed.

THE FOLLOWING AUTHORITY WAS OBTAINED BY TRANSFER OF CERTIFICATE NO. G-135 FROM RICHARD D. HARRIS.

(PID324) SOLID WASTE COLLECTION SERVICE in the Town of Concrete, Skagit County, Washington, using as a boundary the corporate limits as of March 15, 1965.

THE FOLLOWING AUTHORITY WAS OBTAINED BY TRANSFER OF CERTIFICATE NO. G-91 FROM STANWOOD CAMANO DISPOSAL, INC.

(PID457) GARBAGE COLLECTION SERVICE on Camano Island, Island County;

(PID334) SOLID WASTE COLLECTION SERVICE on Guemes Island in Skagit County.

THE FOLLOWING AUTHORITY WAS TRANSFERRED TO G-41; CERTIFICATE G-237 NO LONGER AUTHORIZES ANY SOLID WASTE COLLECTION SERVICE IN THAT PORTION OF KING COUNTY DESCRIBED AS FOLLOWS:

(PID372) Starting at the intersection of East Lake Sammamish Parkway and NW Gilman Blvd.; then northwest along NW Gilman Blvd. to its intersection with NW Mall Street, extended (also the south line of Sec. 21, T24N, R6E); then west along NW Mall Street., extended, to its intersection with 17th Ave. NW (also Renton-Issaquah Rd.); then north along 17th Ave. NW to its intersection with I-90; then west along I-90 to the intersection of 188th Ave. SE, extended; then north along 188th Ave. SE extended to the shoreline of Lake Sammamish; then east along the shoreline of Lake Sammamish to its intersection with the north boundary of Lake Sammamish State Park; then east along the north boundary of Lake Sammamish State Park to its intersection with East Lake Sammamish Parkway; then southerly along the East Lake Sammamish Parkway to its intersection with NW Gilman Blvd., the point of beginning.

THE FOLLOWING AUTHORITY HAS BEEN REVISED TO REFLECT A PORTION TRANSFER TO G-14 AND TO DELETE DUPLICATION IN THE REMAINING AUTHORITY.

WASHINGTON UTILITIES AND TRANSPORTATION COMMISSION

Continuation Page

(PID325) SOLID WASTE COLLECTION SERVICE in that portion of Whatcom County described as follows: Starting at the northwest corner of Section 4, T40N, R10EWM; thence south on the west line of said section to the northeast corner of Section 20, T39N, R10EWM; thence west on the north line of said section to the northwest corner of Section 22, T39N, R9EWM; thence south on the west line of said section to the northeast corner of Section 33, T39N, R9EWM; thence west on the north line of said section to the northwest corner of Section 36, T39N, R8EWM; thence south on the west line of said section to the southwest corner of Section 36, T37N, R8EWM (also the Whatcom-Skagit County line); thence east along the south township line of T37N (also the Whatcom-Skagit County line) to its intersection with the Whatcom-Okanogan County line (near the south line of Section 33, T37N, R17EWM); thence northerly along said county line to its intersection with the north line of Section 10 T40N, R16EWM); thence west along said township line to the northwest corner of Section 4, T40N, R10EWM, the point of beginning.

THE FOLLOWING AUTHORITY HAS BEEN REVISED TO REMOVE DUPLICATION RESULTING FROM THE TRANSFER OF AUTHORITY FROM G-38 BREM-AIR DISPOSAL, INC.

(PID376) SOLID WASTE COLLECTION SERVICE in Kitsap County EXCLUDING the following areas: Blake Island; the City of Bainbridge Island as of February 1, 2002; and the City of Poulsbo as of September 12, 1961; EXCLUDING: The City of Bremerton as the point of origin and destination for the same shipment using as a boundary the corporate limits as of September 6, 1960.

(PID429) SOLID WASTE COLLECTION SERVICE in that portion of Benton County described as follows: Beginning at the southeast corner of Section 9, T8N, R26E; thence west along the south line of said Section 9 projected to the southwest corner of Section 7, T8N, R24E; thence north along the west line of said Section 7 and the Yakima-Benton County line to the northwest corner of Section 6, T9N, R24E; thence east along the north line of said Section 6 extended to the northeast corner of Section 1, T9N, R25E; thence south along the east line of said Section 1 extended to the southeast corner of Section 24, T9N, R25E; thence east along the south line of said Section 24 projected to the northeast corner of Section 28, T9N, R26E; thence south along the east line of said Section 28 extended to the southeast corner of Section 9, T8N, R26E, the place of beginning.

(PID428) SOLID WASTE COLLECTION SERVICE in that portion of Benton County described as follows: Starting at the point where the west line of Section 2, T5N, R28E intersects with the north bank of the Columbia River (Wallula Lake); thence north on the west line of said section projected to the northwest corner of Section 26, T6N, R28E; thence west on the north line of said section projected to the southwest corner of Section 24, T6N, R27E; thence north on the west line of said section projected to the southeast corner of Section 26, T7N, R27E; thence west on the south line of said section projected to the southwest corner of Section 29, T7N, R27E; thence north on the west line of said section projected to the southern boundary of the US Department of Energy Hanford Site (within Section 8, T10N, R27E); thence west along the southern boundary of the Hanford Site boundary to its intersection with the east line of Section 23, T11N, R24E, thence south along the east line of said section to its southeast corner; thence west along the south line of said section extended to the southwest corner of Section 19, T11N, R24E; thence north along the west line of said section (also the Benton-Yakima County Line) to its intersection with the northwest corner of Section 18, T13N, R24E; thence east along the north line of said section extended to its intersection with the Hanford Site boundary (also the east line of Section 17, T13N,

WASHINGTON UTILITIES AND TRANSPORTATION COMMISSION

Continuation Page

R24E); thence north along said boundary to its intersection with the centerline of the Columbia River (also the Benton-Grant County Line); thence easterly and southerly along said centerline to its intersection with the Hanford Site boundary (in Section 23, T12N, R28E); thence west along said boundary to its intersection with the westerly shoreline of the Columbia River (also in Section 23, T12N, R28E); thence southerly, easterly, and westerly along the shoreline of the Columbia River to the west line of Section 2, T5N, R28E, the point of beginning.

(PID420) SOLID WASTE COLLECTION SERVICE In that portion of Chelan County described as follows: Beginning at the intersection of the centerline of the Columbia River (The Chelan-Douglas County line) and the south line of Section 21, T21N, R22E; thence west on the south line of said section extended to the point where it intersects with the Chelan-Kittitas County Line; (south line of Section 22, T21N, R19E); thence following said county line in northwesterly direction to its intersection with the west line of Section 18, T22N, R17E; thence north on the west line of said section extended to the north line of Section 6, T25N, R17E; thence west on the north line of said section extended to the southwest corner of Section 31, T26N, R15E; thence north on the west line of said section (including service along State Highway 2 to its intersection with the King-Chelan County Line) to the northwest corner of Section 6, T26N, R15E; thence east on the north line of said section extended to the southwest corner of Section 31, T27N, R16E; thence north on the west line of said section extended to its intersection with the northwest corner of Section 6, T27N, R16E; thence east on the north line of said section extended to the northeast corner of Section 1, T27N, R18E; thence south on the east line of said section extended to the southeast corner of Section 36, T26N, R18E; thence east on the south line of said section extended to the southwest corner of Section 36, T26N, R19E; thence north on the west line of said section extended to the northwest corner of Section 13, T26N, R19E; thence east on the north line of said section extended to its intersection with the Chelan-Douglas County Line (also the centerline of the Columbia River); thence south along the centerline of the Columbia River to its intersection with the south line of Section 21, T21N, R22E, the point of beginning.

(PID421) SOLID WASTE COLLECTION SERVICE in Douglas County EXCLUDING the following territory: Beginning at the northeast corner of Section 1, T29N, R26E; thence west along the north line of said Section 1 extended to the centerline of the Columbia River (also the Okanogan-Douglas County line); thence southerly, westerly, northerly, then southerly again along the centerline of the Columbia River to its intersection with the south line of Section 13, T28N, R23E; thence east along the south line of said Section 13 extended to the southeast corner of Section 13, T28N, R26E; thence north along the east line of said Section 13 extended to the northeast corner of Section 1, T29N, R26E, the point of beginning.

(PID422) SOLID WASTE COLLECTION SERVICE in those portions of Grant County described as follows: Beginning at the intersection of the centerline of the Columbia River and the north line of Section 6, T19N, R23E extended; thence east along said extended north line to the northeast corner of said Section 6; thence south on the east line of said section to the southeast corner of said section; thence east on the south line of said section extended to the northeast corner of Section 12, T19N, R23E; thence south on the east line of said section extended to the southeast corner of Section 24, T19N, R23E; thence west on the south line of said section extended to the northeast corner of Section 29, T19N, R23E; thence south on the east line of said section extended to the northeast corner of Section 32, T18N, R23E; thence east on the north line of said section extended to the northeast corner of Section 36, T18N, R23E; thence south along the east line of said section extended to the northwest corner of Section 18, T16N, R24E; thence east along the north line of said section extended to the northeast corner of Section 13, T16N,

WASHINGTON UTILITIES AND TRANSPORTATION COMMISSION

Continuation Page

R25E; thence south along the east line of said section extended to the centerline of the Columbia River (also the Grant-Benton County line); thence westerly and northerly along said centerline to its intersection with the north line of Section 6, T19N., R23E extended, the point of beginning. (PID423) Also, Sections 28, 29, 32 and 33, T19N, R24E, and Sections 5 and 6, T18N, R24E. (PID424) Also that portion of Grant County known as Crescent Bar in Sections 19 and 30, T20N, R23E. (PID425) Also, that portion of Grant County within T28N and R30E.

(PID426) SOLID WASTE COLLECTION SERVICE in those portions of Okanogan and Lincoln Counties described as follows: Beginning at the southeast corner of Section 36, T28N, R31E; thence west along the south line of said section to its intersection with the southwest corner of Section 31, T28N, R31E; thence north along the west line of said section extended to its intersection with the centerline of the Columbia River; thence northerly along said centerline to its intersection with the north line of Section 2, T29N, R30E; thence east along the north line of said section extended to the northeast corner of Section 1, T29N, R31E; thence south along the east line of said section extended to the southeast corner of Section 36, T28N, R31E, the point of beginning.

(PID427) SOLID WASTE COLLECTION SERVICE in Kittitas County.

(PID410) SOLID WASTE COLLECTION SERVICE in that portion of Spokane County described as follows: Beginning at the intersection of the centerline of the Spokane River with the Spokane-Stevens County Line (within Section 32, T27N, R42E); thence north along said county line to the north line of Section 5, T28N, R42E; thence east along the north line of said section extended to the city limits of Deer Park (in Section 34, T29N, R42E); thence northerly and easterly in a clockwise direction along said city limits to its intersection with the south line of Section 32, T29N, R43E; thence east along the extended south line of said Section 32 to the southwest corner of Section 34, T29N, R43E; thence north along the west line of said Section 34 to the northwest corner of said Section 34; thence east along said Section 34 to the northeast corner of said Section 34; thence south along the east line of said Section 34 to the southwest corner of Section 35, T29N, R43E; thence east along the south line of said Section 35 extended to the northeast corner of Section 1, T28N, R44E; thence south along the east line of said section extended to the southeast corner of Section 12, T28N, R44E; thence east along the south line of said section extended to the northeast corner of Section 16, T28N, R45E; thence south along the east line of said section to the southeast corner of Section 33, T28N, R45E; thence west along the south line of said section to the southeast corner of Section 31, T28N, R45E; thence south along the east line of said section to the southeast corner of Section 7, T26N, R45E; thence east along the south line of said section extended to the northeast corner of Section 17, T26N, R45E; thence south along the east line of said section to the southeast corner of said section; thence east along the south line of said section extended to the northeast corner of Section 22, T26N, R45E; thence south along the east line of said section to the northwest corner of the southwest quarter of Section 35, T26N, R45E; thence east along the north line of said quarter section to the northeast corner of the southeast quarter of Section 36, T26N, R45E; thence south along the east line of said quarter section extended to the southeast corner of Section 25, T25N, R45E; thence west along the south line of said section extended to the northeast corner of Section 36, T25N, R44E; thence south along the east line of said section to the northwest corner of the southwest quarter of Section 31, T25N, R45E; thence east along the north line of said quarter section extended to the northeast corner of the southeast quarter of Section 31, T25N, R45E; thence south along the east line of said quarter section extended to the southeast corner of Section 7, T24N, R45E; thence west along the south line of said section extended to the southeast corner of Section 11, T24N, R44E; thence north along

WASHINGTON UTILITIES AND TRANSPORTATION COMMISSION

Continuation Page

the east line of said section to the northeast corner of said section; thence west along the north line of said section to the northwest corner of said section; thence south along the west line of said section to the southwest corner of said section; thence west along the south line of said section extended (including service on Dishman-Mica Road to its intersection with Madison Road) to the southwest corner of Section 7, T24N, R44E; thence south on the west line of said section extended to the southeast corner of Section 13, T24N, R43E; thence west along the south line of said section to the southwest corner of said section; thence south along the west line of said section extended to the southeast corner of Section 35, T24N, R43E; thence west on the south line of said section extended to its intersection with the centerline of Highway 195; thence northerly along said centerline of Highway 195 to its intersection with the city limits of Spokane (within Section 8, T24N, R43E); thence westerly and northerly in a clockwise direction along said city limits to its intersection with the centerline of the Spokane River (within Section 10, T25N, R42E); thence northwesterly along said centerline to its intersection with the Spokane-Stevens County Line (within Section 32, T27N, R42E), the point of beginning.

(PID411) SOLID WASTE COLLECTION SERVICE excluding service in containers of twenty (20) cubic yard capacity or over in that portion of Spokane County described as follows: Beginning at the northeast corner of Section 30, T26N, R46E; thence south along the east line of said section (also the Washington-Idaho State line) to the southeast corner of Section 30, T25N, R46E; thence west along the south line of said section to the southwest corner of said section; thence north along the west line of said section to the southeast corner of the northeast quarter of Section 36, T26N, R45E; thence west along the south line of said quarter section extended to the west line of Section 35, T26N, R45E; thence north along the west line of said section to the northwest corner of Section 26, T26N, R45E; thence east along the north line of said section to the northeast corner of Section 30, T26N, R46E, the point of beginning.

(PID412) Also, the north half of Section 31, T25N, R45E.

TO THE EXTENT THAT THE AUTHORITY GRANTED IN THIS ORDER DUPLICATES ANY AUTHORITY PREVIOUSLY GRANTED OR NOW HELD SHALL NOT BE CONSTRUED AS CONFERRING MORE THAN ONE OPERATING RIGHT NOR SHALL ANY DUPLICATING RIGHTS BE AVAILABLE FOR PURPOSES OF TRANSFER.

Note: PID reference numbers are used by the Commission for mapping purposes only.

TG-110023

01-06-11

WM000020

Tariff No. 1

of

Waste Management of Washington, Inc.
(Name of Solid Waste Collection Company)

WM – Healthcare Solutions of Washington
(Registered trade name of Solid Waste Collection Company)
Certificate Number G- 237

**NAMING RATES FOR THE COLLECTION, TRANSPORTATION, AND DISPOSAL OF
SOLID WASTE, AND IF NOTED, RECYCLING AND YARDWASTE
IN THE FOLLOWING DESCRIBED TERRITORY:**

The legal service territory as reflected in G-237

(NOTE: If this tariff applies in only a portion of a company's certificate authority,
a map accurately depicting the area in which the tariff applies must be attached to the tariff)

Name of person issuing tariff: Michael A. Weinstein
Mailing address of issuing agent: 13225 NE 126th Place
City, State/Zip Code: Kirkland, Washington 98034
Telephone number, including area code: (425) 814-7840
FAX number, if any: (425) 814-7866
E-mail address, if any: mweinstein@wm.com

Official UTC requests for information
regarding consumer questions and/or
complaints should be referred to the
following company representative:

Name: Michael Weinstein
Title: Senior Pricing Manager
Phone: (425) 814-7840
E-Mail: mweinstein@wm.com
Fax: (425) 814-7866

Issued by: Michael A. Weinstein, Senior Pricing Manager, Pacific Northwest Market Area

Issue date: March 18, 2011

Effective date: March 21, 2011

(For Official Use Only)

Docket No. TG- _____ Date: _____ By: _____

Tariff No. 1

Original Page No. 3

Company Name/Permit Number: Waste Management of Washington, Inc./G-237

Registered Trade Name: WM – Healthcare Solutions of Washington

Index of Items in This Tariff

- Item 5 – Taxes
 - Item 10 – Application of Rates – General
 - Item 14 – Charges for lost containers
 - Item 15 – Maximum Weights
 - Item 20 – Limitation of Service
 - Item 30 – Rate Schedule (Biomedical Waste except Pathological and Chemotherapy Wastes)
 - Item 60 – Delinquent Fees
 - Item 70 – Special Handling or Packaging Charges
 - Item 80 – On-call or Less than Monthly service
 - Item 90 – Rates for Pathological/Trace Chemotherapy Waste
 - Item 300 – List of Abbreviations and Symbols Used in Tariff
-

Index by topic

| | <u>Item No.</u> |
|--|-----------------|
| Abbreviations used in tariff | 300 |
| Application of Rates - Taxes..... | 5 |
| Application of Rates - General..... | 10 |
| Charges for Lost Containers | 14 |
| Delinquent Fees | 60 |
| Limitations of Service..... | 20 |
| Maximum Weights | 15 |
| On-call or Less than monthly service..... | 80 |
| Special Handling or Packaging Charges..... | 70 |
| Rate Schedule (Biomedical Waste except Pathological and Chemotherapy Wastes) | 30 |
| Rate Schedule for Pathological/Trace Chemotherapy Wastes) | 90 |
| Symbols used in tariff | 300 |

Issued by: Michael A. Weinstein, Senior Pricing Manager, Washington Market Area

Issue date: March 18, 2011

Effective date: March 21, 2011

(For Official Use Only)

Docket No. TG- _____ Date: _____ By: _____

WM000023

Item 5 – Application of Rates – Taxes

In addition to the rates shown in the remainder of the tariff, the following taxes apply:

| Entity imposing tax: | Ordinance number: | Amount of tax: | Application (Commodities and territory) |
|-----------------------|-------------------|----------------|---|
| City of Burien | 368 | 6.38% | Utility Tax on all services within City |
| City of Brier | 363 | 6.38% | Utility Tax on all services within City |
| City of Enumclaw | 1888 | 8.00% | Utility Tax on all services within City |
| City of Edmunds | 3432 | 6.38% | Utility Tax on all services within City |
| City of Gold Bar | 417 | 6.38% | Utility Tax on all services within City |
| City of Lynnwood | 2746 | 6.38% | Utility Tax on all services within City |
| City of Woodinville | 200 | 4.00% | Utility Tax on all services within City |
| Town of La Conner | 712 | 3.00% | Utility Tax on all services within City |
| Town of Hamilton | 246 | 6.38% | Utility Tax on all services within City |
| Swinomish Reservation | 126 | 3.00% | Utility Tax on all services within the reservation |
| City of Sedro-Woolley | 1499-05 | 2.00% | Utility Tax on all services within City |
| City of Poulsbo | 2003-32 | 6.38% | Utility Tax on all services within City |
| City of Spokane | C-34025 | 25.00% | Utility Tax on all services within City |
| City of George | 166 | 4.00% | Utility Tax on all services within City |
| City of Ellensburg | 3609 | 7.60% | Utility Tax on all services within City |
| City of Kittitas | 328 | 6.00% | Business and Occupation Tax on all services within City |
| Benton County | 97-082 | 4.50% | Utility Tax on all services within unincorporated Benton County |

Issued by: Michael A. Weinstein, Senior Pricing Manager, Washington Market Area

Issue date: March 18, 2011

Effective date: March 21, 2011

(For Official Use Only)

Docket No. TG- _____ Date: _____ By: _____

Item 10 – Application of Rates – General

The rates contained in this tariff cover the utilization by a medical waste generator of WM – Healthcare Solutions of Washington’s transportation and medical waste management program.

Unless otherwise specified, the rates include the following:

1. Use of Waste Management’s unique containers or other containers that are within the guidelines (US Dept. of Transportation, State and/or Local Regulations) for Medical Waste (Biohazard Waste) storage and transportation and have been approved prior by Waste Management.
2. Medical waste tracking and documentation
3. Transportation; and
4. Treatment and disposal

Unless otherwise provided herein, rates contained in this tariff apply to the transportation of biohazardous or biomedical waste, as defined in WAC 480-70-041.

Item 14 – Charges for Lost Containers

Customers will be charged for lost containers as follows:

\$2.50 per Bio Box

\$40.00 for each small or large reusable tub

Item 15 – Maximum Weights

The maximum weight allowed per container is:

| <u>Container Size</u> | <u>Maximum Weight</u> |
|------------------------------|------------------------------|
| 23 Gallon Cardboard Box | 35 pounds |
| 30 Gallon Cardboard Box | 50 pounds |
| Small Reusable Tub (31 gal.) | 60 pounds |
| Large Reusable Tub (43 gal.) | 60 pounds |

Issued by: Michael A. Weinstein, Senior Pricing Manager, Washington Market Area

Issue date: March 18, 2011

Effective date: March 21, 2011

(For Official Use Only)

Docket No. TG- _____ Date: _____ By: _____

Item 20 – Limitations of Service

1. WM – Healthcare Solutions of Washington will not knowingly accept shipments including containers which are not properly packaged or identified.

2. WM – Healthcare Solutions of Washington may refuse to accept shipments not immediately available for pickup at designated pickup areas adjacent to a loading dock or otherwise immediately accessible to WM – Healthcare Solutions of Washington vehicles.

3. All manifesting paperwork must be properly completed by the generator, verified, appropriately signed and available at the time of pickup.

4. WM – Healthcare Solutions of Washington may refuse to pick up materials from points where the designated pickup area is obstructed at the time of pickup.

5. Rates include normal wear and tear on reusable containers. Reusable containers provided to the generator for the storage of biomedical waste shall remain the property of WM – Healthcare Solutions of Washington. Charges for replacement of reusable containers lost by the generator are shown in Item 14.

7. WM – Healthcare Solutions of Washington will not knowingly accept containers for shipment unless they have a sealed bag liner.

8. The generator shall not tender and WM – Healthcare Solutions of Washington shall not knowingly accept for transportation any container which:
 - a. is not sealed and properly labeled;
 - b. is punctured or materially damaged;
 - c. is overfilled or overweight;
 - d. contains anything other than biomedical waste; or
 - e. contains radioactive materials as defined by the U.S. Nuclear Regulatory Commission.

In the event WM – Healthcare Solutions of Washington inadvertently accepts a container described in this paragraph 8, Item 70 shall apply.

9. WM – Healthcare Solutions of Washington shall not knowingly accept for transportation any shipment which does not meet packing, labeling and handling requirements imposed or required by law.

Issued by: Michael A. Weinstein, Senior Pricing Manager, Washington Market Area

Issue date: March 18, 2011

Effective date: March 21, 2011

(For Official Use Only)

Docket No. TG- _____ Date: _____ By: _____

Tariff No. 1

Original Page No. 7

Company Name/Permit Number: Waste Management of Washington, Inc./G-237

Registered Trade Name: WM – Healthcare Solutions of Washington

Item 30

Rate Schedule (Biomedical Waste except Pathological and Chemotherapy Wastes) – Price per Gallon

| <u>Gallons</u> | <u>Price per Gallon</u> |
|----------------|-------------------------|
| 50 or less | \$ 1.45 |
| 51-100 | \$ 1.10 |
| 101-200 | \$ 0.80 |
| 201-400 | \$ 0.60 |
| 401-600 | \$ 0.48 |
| 601-800 | \$ 0.36 |
| 801-1,000 | \$ 0.30 |
| 1,001-2,000 | \$ 0.28 |
| 2,001 + | \$ 0.25 |

Note 1: Rates to be charged shall be based upon the total number of gallons per pickup, excluding containers rated under Item 90 which are charged at a flat rate per container. Rates shown above include appropriate/compliant containers as reflected in Item 15 and one approved liner/bag for each container. Rates stated in this Item are in addition to the charges specified in Items 60, 70 and 80.

Note 2: On call service is available with a **\$20.00** setup/delivery fee. (see Item 80)

Note 3: Special Events/Convention Service available with a **\$95.00** setup/delivery fee (see Item 80)

Item 60 – Delinquent Fees

In addition to the rates and charges shown herein, a late charge in the amount of one percent (1%) will be added to any account which remains unpaid at the time of the next regular billing.

Item 70 – Special Handling or Packaging Charges

The following charges will be assessed when the carrier is required to provide special handling or packaging because of the improper packaging of the material shipped by the generator; the shipment of improper waste materials; overweight containers or the generator’s special loading requirements:

Overweight Containers are charged at an additional: **\$12.00** per occurrence per container.

Other improperly packaged containers listed in Item 20 (part 8 letters d and e) are charged **\$50.00** per container plus any other costs incurred to insure unacceptable waste is handled in accordance with all pertinent regulations.

Issued by: Michael A. Weinstein, Senior Pricing Manager, Washington Market Area

Issue date: March 18, 2011

Effective date: March 21, 2011

(For Official Use Only)

Docket No. TG- _____ Date: _____ By: _____

Item 80 – On-call service

An additional fee of **\$20.00** to the rates reflected in Item 30 will be assessed when services are requested on an on-call basis or when the customers’ containers are not accessible at the time of a scheduled pickup. When on-call service is requested, the company will schedule a pickup within a reasonable time after the request for pickup is received from the generator.

Special Event/Convention or One Time Pick Up – Set Up/Delivery Charge- **\$95.00** in addition to the rates reflected in Item 30.

Item 90 – Rates for Pathological/Trace Chemotherapy Waste

1. Pathological and Trace Chemotherapy Waste - **\$20.00** per 23-gallon box

2. Pathological and Trace Chemotherapy Waste - **\$25.00** per 30-gallon box

The rates stated in this Item 90 are flat rates per container include one approved liner/bag and do not vary with the number of containers tendered for pickup. WM – Healthcare Solutions of Washington will require all Pathological Waste and Chemotherapy Waste to be packaged by the generator in small or medium bio boxes provided by WM – Healthcare Solutions of Washington. Charges will also be assessed under Items 60, 70, and 80, when applicable.

For purposes of this Item 90:

“Pathological Waste” means “Pathological waste,” as defined in the definition of “Biomedical waste” found at WAC 480-70-041.

“Chemotherapy Waste” means sharps, syringes, IV tubing/bags/bottles, vials, and other discarded contaminated items generated in the preparation and administration of cytotoxic/antineoplastic drugs. Only empty containers/bags are acceptable with residue not to exceed 3% of total volume.

Issued by: Michael A. Weinstein, Senior Pricing Manager, Washington Market Area

Issue date: March 18, 2011

Effective date: March 21, 2011

(For Official Use Only)

Docket No. TG- _____ Date: _____ By: _____

Tariff No. 1

Original Page No. 9

Company Name/Permit Number: Waste Management of Washington, Inc./G-237

Registered Trade Name: WM – Healthcare Solutions of Washington

Item 300 – List of Abbreviations and Symbols Used in This Tariff

(A) Denotes increases.

(R) Denotes decreases.

(C) Denotes changes in wording, resulting in neither increases or decreases.

(N) Denotes new rates, services, or rules

*** Denotes that material previously shown has been deleted.

Issued by: Michael A. Weinstein, Senior Pricing Manager, Washington Market Area

Issue date: March 18, 2011

Effective date: March 21, 2011

(For Official Use Only)

Docket No. TG- _____

Date: _____

By: _____

WM000029

Exhibit 13

Environmental Health Services Division

401 Fifth Avenue, Suite 1100
Seattle, WA 98104-1818

206-205-4394 Fax 206-296-0189

TTY Relay: 711

www.kingcounty.gov/health



Solid Waste Facility Permit # PR0080378

Effective: January 1, 2012 Expires: December 31, 2012

Permit facility type: Biomedical Waste Treatment Facility

Name of Facility: Waste Management Biomedical Waste Treatment Facility

Facility Location: 149 SW Kenyon Street, Seattle, WA 98108

Mailing address: Waste Management, 8111 1st Ave S., Seattle, WA 98108

Email Address: jdaub@wm.com
Facility Owner: Waste Management

Facility Operator: Waste Management
Jeffery Daub Senior District Manager
Waste Management - Pacific Northwest

Phone: (206) 406-3030 Cellular
(206) 505-9163

SUBJECT TO ALL STATE LAWS, COUNTY BOARD OF HEALTH RULES AND REGULATIONS, AND/OR CITY OR COUNTY ORDINANCES PERTAINING THERETO. THIS PERMIT MAY BE SUSPENDED OR REVOKED UPON VIOLATION BY THE HOLDER OF ANY OF THE TERMS OF THESE REGULATIONS. THIS PERMIT IS NOT TRANSFERABLE AND MUST BE POSTED IN A CONSPICUOUS PLACE. THIS PERMIT IS NOT VALID UNLESS SIGNED BY OPERATOR. NEW OPERATORS MUST APPLY AND PAY FOR A NEW PERMIT BEFORE BEGINNING OPERATION.

This facility shall operate in accordance with the approved plan of operation. Deviations from or changes to the plan must be submitted in writing and approved by Seattle-King County Department of Public Health (SKCDPH) prior to implementation. Further conditions of this permit are contained on the following pages.

SEATTLE-KING COUNTY DEPARTMENT OF PUBLIC HEALTH
David Fleming, MD Director and Health Officer

By: Bill Lasby
Bill Lasby, Supervisor
Solid Waste and Rodent Control Programs

X Jeffery Daub
Operator Signature

Date of issuance: March 13, 2012

WM000701

Section 1. General Permit Conditions

A. The holder of this permit shall comply with King County Board of Health 10.07 for Bio Medical Waste Treatment Facility, WAC 173-350-700, 710 & 715, as well as all applicable local, state and federal regulations. Where any conflicts between any regulations exist, the more stringent shall apply. It is the responsibility of the permittee to remain informed of these regulations.

B. All conditions of this permit shall be binding in order for the permit to remain valid. The permittee shall bear responsibility for the actions and omissions of all facility agents and contractors. This condition shall remain in effect for the life of the facility, including closure activities.

C. The permittee shall allow authorized representatives of the SKCDPH to inspect the facility, equipment and records at any reasonable time, regardless of prior knowledge of the inspection.

D. The permittee shall notify the **SKCDPH Solid Waste office at 206-205-4394** immediately of any spills, releases, contaminations, or threats to human health or the environment, while taking all necessary measures to protect the same.

E. SKCDPH may suspend or revoke this permit if the permittee:

- fails to adhere to the terms of this permit and the plan of operation when approved by SKCDPH,
- fails to meet the compliance schedule
- fails to meet all applicable regulations, or
- fails to provide all information that could be deemed pertinent to the issuance of the permit in an accurate, complete form.

Section 2. Specific Permit Conditions

A. The permittee is authorized to operate a Bio Medical Waste Treatment facility for the collection, treatment, recycling, exchange, storage, consolidation, and/or transfer of Bio Medical Waste as defined in King County Board of Health 10.07.010 (A) except where specifically limited in this permit as later defined.

B. The facility is restricted to accepting cultures and stocks; human blood and blood products, and sharps as defined in King County Board of Health 10.07.010 and as described in Section 1 (a) (b) (c) of the Waste Management Healthcare Solutions Biomedical Waste Operating plan for Waste Management of Washington Seattle Biomedical Treatment Facility (WMHSBWOP) dated **June 2011**. Pathological, chemotherapy and non-hazardous pharmaceuticals wastes may be received at this site only for temporary storage (90 days maximum) in a refrigerated storage trailer until shipped for incineration.

C. Treatment of Biomedical waste: Treatment of those wastes identified in the WMHSBWOP shall be by steam sterilization using the Turbo Machine Company product as upgraded and enlarged by Chemithon Constructors of Seattle, and described in the WMHSBWOP Appendix

G. The autoclave (Steam sterilization) treatment process using the above unit will be operated according to Section 4 or the WMHSBWOP. All audit procedures for critical equipment, and ongoing verification of waste treatment will be completed per the submitted WMHSBWOP, or any health officer approved amendment.

D: The source of the Biomedical Waste will be limited to the generators as listed in the WMHSBWOP. Any changes in the source would have to be approved as an amendment to the permit and an update to the WMHSBWOP.

E. This facility shall provide an internal review annually of The WMHSBWOP, and shall provide two copies to the Health Office for review and approval of any significant change to the plan in terms of waste accepted, treatment method, and disposal of treated waste. The WMHSBWOP shall provide all of the information as specified in King County Board of Health 10.07.060 (A). This plan shall be available onsite for inspection at the request of the health officer.

F. The storage and containment of the biomedical waste shall be in a manner and location which affords protection from animals, rain and wind; does not provide a breeding place of food source for insects or rodents, and is accessible only to personnel authorized in the biomedical waste generator's biomedical wastes management plan.

The storage, containment, and treatment of the biomedical waste shall be per the chart on Page 6 and per the description in Section 3 of the submitted WMHSBWOP or per any written amendment to this plan approved by the health officer. This includes maximum storage time of biomedical waste including time in the transporter and onsite being 15 days for non refrigerated waste and 90 days for refrigerated waste unless approved by the Health officer.

The storage area for the biomedical waste shall be clearly labeled as specified in King County Board of Health 10.07.060(D)(3) and be kept locked and accessible only to authorized personnel at all times King County Board of Health 10.07.060 (D)(2).

G. All biomedical waste transportation vehicles shall be separately permitted by Seattle King County Health Department per King County Board of Health 10.07.030, meet the construction requirements of King County Board of Health 10.07.050 and operate any vehicle per King county Board of Health 10.07.040 and the approved Biomedical Waste Operating Plan.

H. Waste Management shall provide to Seattle King County Health Department an initial listing of the Infection control staff/committee members, phone numbers of responsible individuals and the plant administrator, plant manager, Plan lead, and environmental manager as listed in the WMHSBWOP, Section 6 Supervising and staffing. Additionally, Waste Management shall provide this information annually or more frequently whenever there is a change in the responsible personnel for infection control.

Section 3. Minimum Performance Standards

A. The permittee and all agents or contractors shall:

- (1) Design, construct, operate, and close the facility in a manner that does not pose a threat to human health or the environment;
- (2) Comply with chapter 90.48 RCW, Water Pollution Control and implementing regulations, including chapter 173-200 WAC, Water Quality Standards for Ground Waters of the State of Washington;
- (3) Conform to the approved local comprehensive solid waste management plan prepared in accordance with chapter 70.95 RCW, Solid Waste Management—Reduction and Recycling;
- (4) Not cause any violation of emission standards or ambient air quality standards at the property boundary of the facility and comply with chapter 70.94 RCW, Washington Clean Air Act; and
- (5) Comply with all other applicable local, state and federal laws and regulations.
- (6) Public access is restricted to areas identified in the plan of operation and unauthorized entry is prevented;
- (7) Communication capabilities are provided to summon fire, police, or emergency service personnel;
- (8) The jurisdictional health department and any fire, or emergency the department are notified of any spills or discharges of Biomedical materials to the environment and the steps described in the Section 5 of the WMHSBWOP are followed.

Section 4. Monitoring Requirements

A. Ensure that all routine and annual inspections are completed including:

Inspections and checks performed daily on system equipment to ensure proper operations and detect any conditions requiring unscheduled maintenance or repairs as described in WMHSBWOP Section 3(d) and 4(a) & (c) for autoclave equipment and boiler.

B. Maintain daily operating records of the weights or gallons of each type of biomedical waste received, and processed at this facility. Additionally, maintain all audit records of critical equipment used to process/treat biomedical waste and sharps. Records shall be kept for a minimum of five years and shall be available for inspection at the request of the jurisdictional health department.

C. Prepare and submit a copy of an annual report to the Seattle King County Health by April 1st. The annual report shall detail the facility's activities during the previous calendar year and must include the following information:

- Name and address of the facility;
- Calendar year covered by the report;
- Annual quantity and type of biomedical waste, in pounds or gallons;
- Type of final disposition (e.g., reuse, recycled, treatment, energy recovery, or disposal) by type of biomedical waste;

Section 5. Compliance Schedule

| Due Date | Requirement |
|--------------------------------|--|
| At the next load for transport | Contact Public Health and Ecology 48 hours prior to loading for transport to see the demonstration of the loading process as previously requested. |
| April 1, 2013 | Submit annual report on the facility activities including the quantity and type of biomedical waste autoclaved in pounds or gallons, sharps treated, and biomedical waste sent for incineration. |

Exhibit 14



SOLID WASTE MANAGEMENT
1225 E. MARIETTA
SPOKANE, WASHINGTON 99207-2787
(509) 625-7878

Feb 1, 2012

Jeff Daub
Sr. District Manager
Waste Management Spokane
8111 1st Ave., S.
Seattle, WA 98108

Dear Mr. Daub,

This letter comprises your license to engage in infectious waste collection in the City of Spokane for 2012. Parts of this license include the application form and materials submitted therewith on file with the City Solid Waste Management Department, incorporated herein by reference.

This license creates no property right and is revocable in the event of violation of applicable City ordinances or failure to submit accurate and complete information as required by SMC 10.35 or to update the City Solid Waste Management Department properly in the event of any changes in the information supplied or required to be supplied.

Thank you for your cooperation.

Sincere Regards,

Geoffrey D. Glenn, Disposal Superintendent
Solid Waste Management Department

CC
Steven Holderby
Spokane Regional Health District
1101 West College Avenue
Spokane, WA 99201-2095

WM000037

Exhibit 15

Environmental Health Services Division

401 Fifth Avenue, Suite 1100
Seattle, WA 98104-1818
206-205-4394 Fax 206-296-0189
TTY Relay: 711
www.kingcounty.gov/health



Solid Waste Handling Permit For Vehicles #PR0081085

Effective: July 1, 2012

Expires: June 30, 2013

Permit type: Collection and Transportation Vehicles used to transport biomedical waste over the highways of King County.

Name of Facility: Waste Management Biomedical Transportation Vehicle

Number of Collection and Transportation Vehicles: 1

Location where vehicles are housed: 149 SW Kenyon Street, Seattle, WA 98108

Mailing address: Waste Management
8111-1st Avenue South
Seattle, WA 98108

Facility Owner: Waste Management

Facility Operator: Jeffrey Daub, District Manager

Phone: 206-505-9163
206-406-3030 (cellular)

Email address: jdaub@wm.com

SUBJECT TO ALL STATE LAWS, COUNTY BOARD OF HEALTH RULES AND REGULATIONS, AND/OR CITY OR COUNTY ORDINANCES PERTAINING THERETO. THIS PERMIT MAY BE SUSPENDED OR REVOKED UPON VIOLATION BY THE HOLDER OF ANY OF THE TERMS OF THIS PERMIT OR ANY APPLICABLE LAWS, RULES OR REGULATIONS. THIS PERMIT IS NOT TRANSFERABLE AND MUST BE POSTED IN A CONSPICUOUS PLACE. THIS PERMIT IS NOT VALID UNLESS SIGNED BY OPERATOR. NEW OPERATORS MUST APPLY AND PAY FOR A NEW PERMIT BEFORE BEGINNING OPERATION.

Your vehicle(s) shall operate in accordance with this permit and the permit conditions, and per King County Board of Health Code Chapter 10.07. The permit conditions are elaborated in the attached pages.

SEATTLE-KING COUNTY DEPARTMENT OF PUBLIC HEALTH
David Fleming, MD, Director and Health Officer

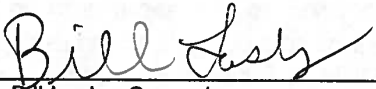
By: 
Bill Lasby, Supervisor
Solid Waste, Rodent and Zoonotics Program

X 
Operator Signature

Date of issuance: August 7, 2012

WM000706

Section 1. General Permit Conditions

- A. The holder of this permit shall comply with King County Board of Health Code (KCBOH) Chapter 10.07 governing biomedical waste collection and transportation vehicles as well as all other applicable local, state and federal regulations. Where any conflicts between any regulations exist, the more stringent shall apply. It is the responsibility of the permittee to remain informed of these regulations.
- B. For the purposes of this permit, "permittee" includes any and all agents and contractors of the permittee. The permittee shall bear responsibility for the actions and omissions of all of permittee's agents and contractors. This condition shall remain in effect for the use of the vehicle (s), including vehicle closure activities.
- C. All conditions of this permit shall be binding upon the permittee, who shall be responsible for all acts and omissions of all contractors and agents of the permittee for the term of this permit.
- D. The permittee shall notify the Seattle King County Department of Public Health (SKCDPH) in writing in advance of any alterations or changes in solid waste handling practices, when these changes are different or absent from the existing permit.
- E. The permittee shall allow the Director of the Seattle-King County Department of Public Health (Director) or the Director's duly authorized inspector, or any duly authorized representative of the Washington State Department of Ecology, to enter any of permittee's buildings, structures, vehicles storage areas, properties or portions thereof at reasonable times whenever it is necessary to make an inspection to enforce or determine compliance with the provisions of this permit, or the provisions of KCBOH Chapter 10.07 or any other applicable rules and regulations, or whenever the Health Officer has reason to believe that a violation of this permit has been or is being committed. This includes access to permittee's records at any reasonable time, regardless of prior knowledge of the inspection.
- F. The permittee shall notify the SKCPH solid waste office at 206-263-9566 immediately of any spills, releases, contaminations, or threats to human health or the environment, and while taking all necessary remedial measures to protect the same. The permittee shall report all instances of non-compliance with this permit or any applicable rules and regulations to SKCDPH in writing within one week of the occurrence.
- G. In accordance with KCBOH Chapter 1.08 and Sections 10.07.020 and 10.07.040, SKCDPH may suspend or revoke this permit for any of the following reasons:

1. The permittee fails to comply with the conditions of this permit, or KCBOH Chapter 10.07;
2. The permittee fails to comply with any notice and order issued pursuant to KCBOH Chapter 1.08 ;
3. The dishonor of any check or draft used by the permit holder to pay any fees required by law or KCBOH Chapter 10.07;
4. The director finds that a violation of KCBOH Chapter 10.07 has created or is creating an unsanitary, dangerous or other condition which, in the judgment of the director, constitutes an immediate and irreparable hazard;
5. The permittee interfering with the Director or his/her authorized representative in the performance of his/her duties; and
6. The discovery by the Director or the Director's authorized representative that a permit was issued in error or on the basis of incorrect information supplied to SKCDPH.

Section 2. Specific Permit Conditions

- A. The permittee is authorized to operate a collection/transportation vehicle(s) (C/T V(s)) for the transport of biomedical waste generated by others over the highways of King County.
- B. The permittee shall transport biomedical waste over public roads only in a leakproof and fully enclosed container or vehicle compartment per KCBOH Section 10.07.040.
 1. The vehicle compartment will be of durable and easily cleanable construction.
- C. Biomedical waste shall not be transported in the same vehicle with other waste or medical specimens unless the biomedical waste is contained in a separate, fully enclosed leakproof container within the vehicle compartment.
- D. Biomedical waste shall be delivered for treatment only to a facility that meets all local, state and federal environmental regulations, as determined by the appropriate local, state, and federal agencies.
- E. The permittee shall retain records of disposal for a period of at least three (3) years, and they shall be available to the Director upon request. All information requested by SKCDPH shall be sent to:

Public Health, Seattle & King County
Environmental Health Services Division
Solid Waste Program
401 Fifth Avenue, Suite 1100
Seattle, WA 98104-1818

- F. Surfaces of biomedical waste collection/transportation vehicles that have contacted spilled or leaked biomedical waste shall be decontaminated as described in KCBOH Chapter 10.07.
- G. Biomedical waste collection and transportation vehicle(s) shall be identified on each side of the vehicle with the name or trademark of the biomedical waste transporter.
- H. Vehicles shall be cleaned frequently to prevent rodent/vector and odor nuisances. In addition, the Director or his designee may require disinfection of any vehicle.
- I. All wastewater from vehicle cleaning shall be disposed of in a sanitary sewer system unless otherwise authorized by the Director.
- J. All operators of a collection/transportation vehicle(s) (C/T V(s)) for the transport of biomedical waste generated by others over the highways of King County shall provide a contingency plan as described in KCBOH Section 10.07.060 (C)(4) and the legal description of the site(s) that the applicant is planning to use to treat biomedical waste.

Section 3. Minimum Performance Standards

A. The permittee shall:

1. Design, construct, and operate the C/T V and the storage location for these vehicles, in a manner that does not pose a threat to human health or the environment;
2. Comply with Chapter 90.48 RCW, Water Pollution Control and implementing regulations, including Chapter 173-200 WAC, Water Quality Standards for Ground Waters of the State of Washington;
3. Conform to the approved local comprehensive solid waste management plan prepared in accordance with chapter 70.95 RCW, Solid Waste Management—Reduction and Recycling;
4. Comply with all other applicable local, state and federal laws and regulations; and
5. Provide communication capabilities to summon fire, police, or emergency service personnel.

B. The permittee shall pay an annual permit fee as a condition of permit issuance as provided for in KCBOH Section 10.07.030.

SKCDPH may establish reasonable fees for permits and permit renewals. A fee schedule has been established by the SKCDPH's Environmental Health Division and approved by the King County Board of Health. The annual permit fee covers the following SKCDPH activities:

1. Permit application review;
 2. Permit drafting/issuance;
 3. Vehicle and facility inspections; and
 4. Responding to complaints.
- C. Pursuant to the current fee schedule, the permittee will be assessed an additional fee for the services listed below. This fee will be based on the time expended by SKCDPH staff billed in accordance with the current fee schedule as provided for in KCBOH Sections 2.14.060 and 2.14.080, as amended.
1. SKCDPH oversight and review required as a result of the Director's determination that the permittee's operation is out of compliance with this permit or applicable regulations;
 2. Amendments to the existing permit; and
 3. Other permit related work beyond those items listed in Section 3.A. above.
- D. Whenever a fee is assessed, SKCDPH will send a billing invoice to the permittee at the most current address on file as provided by the permittee. Within thirty (30) days after receipt of billing, the permittee shall send SKCDPH payment of the assessed amount by check or money order and enclose a copy of the invoice. Payment and a copy of the invoice shall be sent to:

Public Health, Seattle & King County
Environmental Health Services Division
Attention: Solid Waste Program
401 Fifth Avenue, Suite 1100
Seattle, WA 98104-1818

Section 4. Monitoring Requirements

- A. The permittee shall ensure that all routine and annual inspections are completed, including inspections and checks performed daily on vehicles and equipment to ensure proper operations and detection of any conditions requiring regular or unscheduled maintenance or repairs.
- B. Transaction Requirements: Receipts and Recordkeeping.
The permittee shall maintain records as described in described in Section 2.E. above in this permit.

Section 5. Permit Compliance Schedule and Vehicle List

| Due Date | Requirement |
|-----------------|--|
| June 1, 2013 | Submit annual list of vehicles which will be operated by permittee, including the vehicle make, model number, and vehicle license. Submit updates of this list throughout the permit cycle if any new vehicles are added to the fleet, or old vehicles retired, sold, etc. as tabs are NOT transferable. |

2012-2013 Waste Management Biomedical Waste Vehicle List (1 total)

| Vehicle Make | Vehicle Model | License Plate # |
|---------------------|----------------------|------------------------|
| FTL Freightliner | M2 | B52940V |

Exhibit 16



King County

**Wastewater Treatment Division
Industrial Waste Program**

Department of Natural Resources and Parks

130 Nickerson Street, Suite 200

Seattle, WA 98109-1658

206-263-3000 Fax 206-263-3001

TTY Relay: 711

November 1, 2011

**CERTIFIED MAIL
RETURN RECEIPT REQUESTED**

Jeff Daub
Waste Management
8111 First Avenue S.
Seattle, WA 98108

Issuance of Revised Wastewater Discharge Authorization No. 785-03 to Waste Management

Dear Mr. Daub:

The King County Industrial Waste Program has revised your Minor Discharge Authorization to discharge industrial wastewater to the sewer system from the Waste Management operation located at 8101 First Avenue South, Seattle, Washington. The enclosed Discharge Authorization No. 785-03 supersedes and cancels Discharge Authorization No. 785-02, effective November 3, 2011. Chapter 28.84 of the King County Code – Water Pollution Abatement sanctions a fee for each discharge authorization issued by the Department of Natural Resources and Parks. Since this is the second revision of Waste Management's discharge authorization, you will be sent an invoice of \$695 for issuance of a Minor Discharge Authorization in 2011.

The main revision to your discharge authorization is the addition of wastewater from the sterilization of medical wastes collected from local hospitals and wastewater from the washings of the bins holding the bagged medical wastes.

This authorization permits you to discharge limited amounts of industrial wastewater into King County's sewer system in accordance with the effluent limitations and other requirements and conditions set forth in the document and the regulations outlined in King County Code 28.84.060. As long as you maintain good compliance and do not change the nature and volume of your discharge, the formal requirements and fees of a full wastewater permit will not be required.



Creating Resources from Wastewater

WM000045

Jeff Daub
November 1, 2011
Page 2

If you propose to increase the volume of your discharge or change the type or quantities of substances discharged, you must contact the King County Industrial Waste Program at least 60 days before making these changes.

If at any time you have questions about this discharge authorization, or other questions about your wastewater discharge, please call me at 206-263-3017 or email me at lydia.eng@kingcounty.gov. You may also wish to visit our program's Internet pages at: www.kingcounty.gov/industrialwaste.

Thank you for helping support our mission to protect public health and enhance the environment.

Sincerely,



Lydia Eng
Compliance Investigator

Enclosures

cc: Doug Hilderbrand, King County
Julie Howell, Seattle Public Utilities

WM000046



King County

MINOR DISCHARGE AUTHORIZATION

King County Industrial Waste Program
130 Nickerson Street, Suite 200
Seattle, WA 98109-1658

NUMBER 785-03

for

Waste Management - Seattle

Plant Address: 8101 First Avenue S.
Seattle, WA 98108

Mailing Address: 8111 First Avenue S.
Seattle, WA 98108

Phone: 206-406-3030 **Emergency (24-Hour) Phone:** 206-406-3030

Industry Type: Container washing (garbage and recycling totes, bins, compactors and medical waste bins)

SIC Code: 4212 **EPA Id. #:** NA

Sample Site No.: A46051, A46052, and A46053

Discharge To: West Point Treatment Plant

*Note: This authorization is valid only for the specific discharges shown below:

Discharge Process: Wastewater generated from the cleaning and washing of solid waste refuse and recyclables totes, bins, and compactors, and medical waste bins (A46051); external truck washing prior to maintenance or repairs on trucks (A46502); and steam sterilization of international trash from Port of Seattle and steam sterilization of medical wastes from local hospitals (A46503)

Pretreatment Process: Oil/Water/Gravity separation, best management practices

Maximum Volume: Industrial: 5,000 gallons per day (gpd)*

*Total discharge volume from all three sites for any one day shall not exceed 5,000 gpd

Effective Date: March 26, 2008
Revision Date: November 3, 2011
Expiration Date: March 25, 2013

Permission is hereby granted to discharge industrial wastewater from the above-identified facility into the King County sewer system in accordance with the effluent limitations and monitoring requirements set forth in this authorization.

If the industrial user wishes to continue to discharge after the expiration date, an application must be filed for re-issuance of this discharge authorization at least 180 days prior to the expiration date. For information concerning this King County Discharge Authorization please call Industrial Waste Compliance Investigator Lydia Eng at 206-263-3017.

24-HOUR EMERGENCY NOTIFICATION

**West Point Treatment Plant: 206-263-3801
Department of Ecology: 425-649-7000**

SPECIAL CONDITIONS

- A. Waste Management Seattle shall operate and maintain its oil/water/gravity separator in efficient operating condition to maintain consistent compliance with the general discharge limitations contained in this authorization.
- B. Records of oil/water separator cleaning, either by Waste Management Seattle or a commercial cleaner, shall be retained for at least three years.
- C. Waste Management Seattle shall continue to perform best management practices at areas around catch basins to minimize solids and other contaminants from entering the drainage system. Catch basins shall also continue to be maintained on a routine basis.
- D. The use of catch basin plugs and booms surrounding Waste Management Seattle's trucks shall continue to be utilized to contain the wash water whenever the trucks are washed.

GENERAL DISCHARGE LIMITATIONS

Operating Criteria

There shall be no odor of solvent, gasoline, or hydrogen sulfide (rotten egg odor), oil sheen, unusual color, or visible turbidity. The discharge must remain translucent. If any of the discharge limits are exceeded, you must stop discharging and notify the King County Industrial Waste Program at 206-263-3000.

Corrosive Substances

Limits

| | |
|------------------------|----------------|
| Maximum: | pH 12.0 (s.u.) |
| Instantaneous minimum: | pH 5.0 (s.u.) |
| Daily minimum: | pH 5.5 (s.u.) |

The instantaneous minimum pH limit is violated whenever any single grab sample or any instantaneous recording is less than pH 5.0. The daily minimum pH limit is violated whenever any continuous recording of 15 minutes or longer remains below pH 5.5 or when each pH value of four consecutive grab samples collected at 15-minute intervals or longer within a 24-hour period remains below pH 5.5.

Discharges of more than 50 gallons per day of caustic solutions equivalent to more than five percent NaOH by weight or greater than pH 12.0 are prohibited unless authorized by the King County Industrial Waste Program and subject to special conditions to protect worker safety, the collection system, and treatment works.

Fats, Oils, and Grease (FOG)

Discharge of FOG shall not result in significant accumulations that either alone or in combination with other wastes are capable of obstructing flow or interfere with the operation or performance of sewer works or treatment facilities.

Nonpolar FOG (oil and grease from petroleum sources): The three nonpolar fats, oils, and grease (FOG) grab samples shall be of equal volume, collected at least five minutes apart, and analyzed separately. When using EPA approved protocols specified in 40 CFR Part 136, the individual grab samples may be composited (at the laboratory) prior to analysis. The result of the composite sample or the average of the concentrations of the three grab samples may be reported as Total FOG unless the value is 100 mg/L or greater, in which case the concentration of nonpolar FOG must be reported.

Polar FOG (oil and grease from animal and/or vegetable origin): Dischargers of polar FOG shall minimize free floating polar FOG. Dischargers may not add emulsifying agents exclusively for the purpose of emulsifying free floating FOG.

Flammable or Explosive Materials

No person shall discharge any pollutant, as defined in 40 CFR 403.5, that creates a fire or explosion hazard in any sewer or treatment works, including, but not limited to, waste streams with a closed cup flashpoint of less than 140° Fahrenheit or 60° Centigrade using the test methods specified in 40 CFR 261.21.

At no time shall two successive readings on an explosion hazard meter, at the point of discharge into the system (or at any point in the system), be more than five percent nor any single reading be more than 10 percent of the lower explosive limit (LEL) of the meter.

Pollutants subject to this prohibition include, but are not limited to, gasoline, kerosene, naphtha, benzene, toluene, xylene, ethers, alcohols, ketones, aldehydes, peroxides, chlorates, perchlorates, bromates, carbides, hydrides, and sulfides, and any other substances that King County, a fire department, Washington State, or EPA has notified the user are a fire hazard or a hazard to the system.

| Petroleum Compounds | Maximum Concentration ppm (mg/L) |
|----------------------------|---|
| Benzene | 0.07 |
| Ethylbenzene | 1.7 |
| Toluene | 1.4 |
| Total Xylenes | 2.2 |

Heavy Metals/Cyanide

The industrial user shall not discharge wastes, which exceeds the following limitations:

| Heavy Metals & Cyanide | Daily Maximum ppm (mg/L)¹ |
|-----------------------------------|---|
| Arsenic | 4.0 |
| Cadmium | 0.6 |
| Chromium | 5.0 |
| Copper | 8.0 |
| Lead | 4.0 |
| Mercury | 0.2 |
| Nickel | 5.0 |
| Silver | 3.0 |
| Zinc | 10.0 |
| Cyanide | 3.0 |

¹The daily maximum is violated whenever any sample exceeds the limitation.

High Temperature

The industrial user shall not discharge material with a temperature in excess of 65°C (150°F).

Hydrogen Sulfide

Atmospheric hydrogen sulfide: 10.0 ppm
(As measured at a monitoring manhole designated by King County)

Soluble sulfide limits may be established on a case-by-case basis depending upon volume of discharge and conditions in the receiving sewer, including oxygen content and existing sulfide concentrations.

Organic Compounds

No person shall discharge any organic pollutants that result in the presence of toxic gases, vapors, or fumes within a public or private sewer or treatment works in a quantity that may cause worker health and safety problems.

Organic pollutants subject to this restriction include, but are not limited to: Any organic pollutants compound listed in 40 CFR Section 433.11 (e) (total toxic organics (TTO) definition), acetone, 2-butanone (MEK), 4-methyl-2-pentanone (MIBK), and xylenes.

Settleable Solids

Settleable solids concentrations: 7.0 ml/L

GENERAL CONDITIONS

- A. All requirements of King County Code pertaining to the discharge of wastes into the municipal sewer system are hereby made a condition of this discharge authorization.
- B. The industrial discharger shall implement measures to prevent accidental spills or discharges of prohibited substances to the municipal sewer system. Such measures include, but are not limited to, secondary containment of chemicals and wastes, elimination of connections to the municipal sewer system, and spill response equipment.
- C. Any facility changes, which will result in a change in the character or volume of the pollutants discharged to the municipal sewer system, must be reported to your King County Industrial Waste Program representative. Any facility changes that will cause the violation of the effluent limitations specified herein will not be allowed.
- D. In the event the permittee is unable to comply with any of the conditions of this discharge authorization because of breakdown of equipment or facilities, an accident caused by human error, negligence, or any other cause, such as an act of nature the company shall:
 - 1. Take immediate action to stop, contain, and clean up the unauthorized discharges and correct the problem.
 - 2. Immediately notify the King County Industrial Waste Program, 206-263-3000, so steps can be taken to prevent damage to the sewerage system.
 - 3. Submit a written report within 14 days describing the breakdown, the actual quantity and quality of resulting waste discharged, corrective action taken, and the steps taken to prevent recurrence.
- E. Compliance with these requirements does not relieve the permittee from responsibility to maintain continuous compliance with the conditions of this discharge authorization or the resulting liability for failure to comply.
- F. The permittee shall, at all reasonable times, allow authorized representatives of the King County Industrial Waste Program to enter that portion of the premises where an effluent source or disposal system is located or in which any records are required to be kept under the terms and conditions of this discharge authorization.
- G. Nothing in this discharge authorization shall be construed as excusing the permittee from compliance with any applicable federal, state, or local statutes, ordinances, or regulations including discharge into waters of the state. Any such discharge is subject to regulation and enforcement action by the Washington State Department of Ecology.
- H. This discharge authorization does not authorize discharge after its expiration date. If the permittee wishes to continue to discharge after the expiration date, an application must be filed for reissuance of this discharge authorization at least 180 days prior to the expiration date. If the permittee submits its reapplication in the time specified herein, the permittee shall be deemed to have an effective wastewater discharge authorization until the King County Industrial Waste Program issues or denies the new wastewater discharge authorization. If the permittee fails to file its reapplication in the time period specified herein, the permittee will be deemed to be discharging without authorization.

Compliance Investigator: Lydia Eng Date: November 1, 2011
Lydia Eng

Exhibit 17



STATE OF WASHINGTON
DEPARTMENT OF ECOLOGY

Northwest Regional Office • 3190 160th Avenue SE • Bellevue, Washington 98008-5452 • (425) 649-7000

October 11, 2011

Jeff Altman
Waste Management Biomedical Waste Facility
5903 63rd Avenue Ct NW
Gig Harbor, WA 98335

RE: Dangerous Waste Compliance Inspection on September 20, 2011 at Waste Management Biomedical Waste Facility at 149 SW Kenyon Street, Seattle

Dear Mr. Altman:

Ecology's Hazardous Waste and Toxics Reduction Program recently conducted a Dangerous Waste compliance inspection at your facility. The Dangerous Waste Regulations¹ establish a safe and responsible system to manage dangerous waste. I have listed the violations at Waste Management in the enclosed Notice to Comply. You must complete the actions needed to correct these violations and return the enclosed completed **Compliance Certificate** within 30 days of receipt of this letter to the address above.

Failure to comply with these requirements within 90 days could result in an administrative order and a penalty of up to \$10,000 per day for each violation.

If you have any questions or need clarification of the information in this inspection report, please contact me at (425) 649-7090 or daylin.davidson@ecy.wa.gov.

Sincerely,

Daylin Davidson
Hazardous Waste Compliance Inspector
Hazardous Waste and Toxics Reduction Program

DD:SA

By certified mail: 7010 3090 0002 0647 2755

¹ Authority: WAC 173-303 and RCW 70.105.080



WM000133

Washington State Department of Ecology Hazardous Waste and Toxics Reduction Program

| | | |
|-------------------------|---|---------------------------------------|
| RCRA Site ID # None | Facility name Waste Management Biomedical Waste Facility | Inspection date September 20, 2011 |
| Generator status SQG | Facility address 149 SW Kenyon Street, Seattle | Date Report Sent October 11, 2011 |

Notice to Comply

| | |
|--|--|
| Site contact name Jeff Altman | Inspector's Name Daylin Davidson |
| Site phone number (360) 801-5239 | Inspector's Phone Number (425) 649-7090 |
| Site contact e-mail address jaltman2@wm.com | Inspector's e-mail address Daylin.Davidson@ecy.wa.gov |
| Site Website www.wm.com | Back-up Inspector's Name David Keeney & Nannette Brooks |

Notes:

1. A re-inspection can occur at any time to verify the correction of the violations listed below.
2. Ecology may take formal enforcement action even if the violation(s) are corrected.

| WAC 173-303- | Summary of Violations Including Observations | Actions Needed |
|--------------|--|---|
| 070(8)(b)(i) | Waste liquids and sludges have not been designated. WAC 173-303-070(8)(b)(i): Failure to designate waste in order to meet the small quantity generator conditional exemption. | To properly designate all waste streams, you must develop and submit a Sampling Plan and Quality Assurance Project Plan (QAPP) prior to sampling for designation purposes. These two plans are due within 45 days. Completed designation is due within 90 days. Please see the information provided in the Concerns/Suggestions section below. |

Concerns and/or Suggestions

Undesignated Waste Streams

During Ecology's tour of your facility it was noted that the following waste streams have not been properly evaluated for dangerous waste characterization in accordance with the designation procedures set forth at WAC 173-303-070:

- Aqueous effluent generated as a result of condensate formation during operation of the sterilizing steam autoclave
- Sediment build up at the base of the sterilizing steam autoclave trench drain
- Aqueous effluent generated as a result of condensate formation during operation of the portable autoclave
- Rinsate generated during the cleaning of reusable biomedical waste containers
- Sediment build up at the base of the pressure wash pad catch basin
- Wastewater generated during the placement of autoclaved waste into the intermodal trailer
- Sediment build up at the base of the 660 utility vault

Based on the origin of biomedical waste entering this facility, and the lack of on-site screening to ensure no dangerous wastes are present in this biomedical waste stream, sufficient information to properly designate process waste streams resulting from autoclave activities is currently not available. In accordance with WAC 173-30-070(3) and (4), when current evidence is insufficient for determining whether or not a waste

Washington State Department of Ecology Hazardous Waste and Toxics Reduction Program

| | | |
|------------------|--|--------------------|
| RCRA Site ID # | Facility name | Inspection date |
| None | Waste Management Biomedical Waste Facility | September 20, 2011 |
| Generator status | Facility address | Date Report Sent |
| SQG | 149 SW Kenyon Street, Seattle | October 11, 2011 |

designates as dangerous, sampling and laboratory testing is required. As the input stream generating these wastes is considered to be highly variable, the preparation of a Sampling and Quality Assurance Project Plan (SQAP), in accordance with Ecology Publication No. 04-03-030 "Guidelines for Preparing Quality Assurance Project Plans for Environmental Studies", is strongly recommended to ensure the collection of representative samples from the treatment process units. This publication is available online at <http://www.ecy.wa.gov/biblio/0403030.html>. Information presented below may be useful in preparing a SQAP for waste stream designation at your facility.

Constituents of Concern

The list of potential Parameters and Constituents of Concern for a specific waste stream is based on the Dangerous Waste Constituents list (WAC 173-303-9905), as well as the parameters for Identification and Listing of Hazardous Waste under the Resource Conservation and Recovery Act (RCRA) (40 CFR 261). Parameters and Constituents of Concern derived from these regulations can be separated into the following broad categories:

1. Waste Characteristic
 - Ignitability
 - Corrosivity
 - Reactivity (Cyanide/Sulfide)
2. Toxicity Characteristic Leaching Procedure (TCLP)
 - Volatile Organic Compounds (VOCs)
 - Semi-Volatile Organic Compounds (SVOCs)
 - Polychlorinated Biphenyls (PCBs)
 - Chlorinated Herbicides
 - Organochlorine Pesticides
 - RCRA 8 Metals
3. Washington State-Only Criteria
 - Polycyclic Aromatic Hydrocarbons (PAHs)
 - Halogenated Organic Compounds (HOC)
 - Halogenated volatile compounds
 - Haloethers
 - PCBs
 - Chlorinated Herbicides
 - Metals
4. Biological Toxicity
 - Static acute fish toxicity
 - Acute oral rat toxicity

The types of waste processed by Waste Management are not likely to include and PCB, chlorinated herbicide, or organochlorine pesticide constituents. Additionally these constituents are not known or believed likely to form during the treatment process. As such these constituents can be reasonably eliminated from the sampling plan. Additionally, based on process knowledge, these waste streams are not considered likely to display the characteristic of ignitability as described at WAC 173-303-090. As such samples collected need not be evaluated for this parameter.

It is not required that sampling be conducted to analyze for P and U listed pharmaceutical constituents. If these constituents are present in the waste stream it is not possible to determine their origin and therefore it

Washington State Department of Ecology Hazardous Waste and Toxics Reduction Program

| | | |
|-------------------------|---|---------------------------------------|
| RCRA Site ID # None | Facility name Waste Management Biomedical Waste Facility | Inspection date September 20, 2011 |
| Generator status SQG | Facility address 149 SW Kenyon Street, Seattle | Date Report Sent October 11, 2011 |

cannot be determined if they are the sole active ingredient.

Analytical Methods

Based on the information presented above, Ecology proposes, at a minimum, the following parameters and analytic methods for the profiling of currently undesignated aqueous and non-aqueous waste streams at your facility:

• **Aqueous Wastes**

- Corrosivity by EPA Method 9040A
- Reactivity to Cyanide and Sulfide by SW 846-7.3 and 7.4.2
- VOCs by EPA Method 8260B
- SVOCs (including PAHs, nicotine, and lindane) by EPA Method 8270C
- Total Metals (RCRA 8 + Cu, Ni, Zn) by EPA Method 6010B and 7470A
- Static Acute Fish Toxicity by Ecology Method 80-12 Part A

Note: TCLP requirements for testing as put forth in EPA SW-846 are not applicable for the extraction of aqueous liquid wastes as sample preparation would be identical to that for typical aqueous samples and the TCLP leachate. Additionally the constituents of concern derived from the federal toxicity standards (VOCs, SVOCs, and Metals) are the same constituents of concern derived from the Washington State Only criteria. As such analysis for total VOC's, SVOC's including PAHs, and RCRA 8 Metals plus zinc, nickel, and copper can be considered sufficient for designation under both federal and state only criteria.

• **Non-Aqueous Wastes (Vault, Catch Basin and Trench Drain Sediment)**

- Corrosivity by EPA Method 9045
- Reactivity to Cyanide and Sulfide by SW 846-7.3 and 7.4.2
- TCLP VOCs Extraction by EPA Method 1311, analysis by EPA Method 8260B
- TCLP SVOCs (including lindane) Extraction by EPA Method 1311, analysis by EPA Method 8270C
- TCLP Metals (RCRA 8) Extraction by EPA Method 1311, analysis by EPA Method 6010B and 7470A
- VOCs by EPA Method 8260B
- SVOCs (including PAHs, nicotine, and lindane) by EPA Method 8270C
- Total Metals (RCRA 8 + Cu, Ni, Zn) by EPA Method 6010B and 7470A
- Static Acute Fish Toxicity by Ecology Method 80-12 Part A

Sample Collection and Handling

Method specific requirements for the collection and handling of samples are set forth in each of the above referenced analytic procedures. Your SQAP should detail procedures that will be followed for sample collection to ensure these requirements are met. Please refer to the Ecology publication, "Guidelines for Preparing Quality Assurance Project Plans for Environmental Studies" for additional guidance on preparation of a SQAP and sampling procedures.

The purpose of sampling is to provide a true representation of the temporal and spatial variations of the identified waste streams. While the effluent streams generated during each individual autoclave process may potentially be considered homogenous, there is likely a high degree of variability in this waste stream over time due to variance of process inputs. Your SQAP must explain how the proposed sampling frequency addresses the expected temporal variability of parameters of interest in these waste streams.

Washington State Department of Ecology Hazardous Waste and Toxics Reduction Program

| | | |
|-------------------------|---|---------------------------------------|
| RCRA Site ID # None | Facility name Waste Management Biomedical Waste Facility | Inspection date September 20, 2011 |
| Generator status SQG | Facility address 149 SW Kenyon Street, Seattle | Date Report Sent October 11, 2011 |

Compliance Certificate

Instructions:

1. Complete this page **within 90 days of the receipt of the letter.**
Note: You may request an extension before this Compliance Certificate is due. You must make this request in writing and include the reason for the extension and propose a new date of completion.
2. Send this page with any supporting documentation such as photos, copies of manifests/disposal records or receipts, and if applicable, your request for extension, to:

Attn: Daylin Davidson
 Department of Ecology
 3190 160th Ave SE
 Bellevue, WA 98008

| Summary of Hazardous Waste Violation Compliance Action | | | | |
|--|-------|-----------|-----------|-------|
| Check the type of documentation provided | | | | |
| Violation Code | Photo | Paperwork | Statement | Notes |
| 070(8)(b)(i) | | | | |

1. I certify that the violations noted on the Notice to Comply page have been corrected.
2. I personally examined any attached documentation submitted as proof of compliance and I believe the information to be true, accurate, and complete.
3. I am aware:
 - There are significant penalties for submitting false information and/or for non-compliance with regulations.
 - My signature **certifies compliance** with every regulation noted on the Notice to Comply page.
4. I declare under penalty of perjury the foregoing certification is true and correct.

| | |
|----------------|--------------|
| Signature | Printed name |
| Position/title | Date |

Washington State Department of Ecology Hazardous Waste and Toxics Reduction Program

| | | |
|------------------|--|--------------------|
| RCRA Site ID # | Facility name | Inspection date |
| None | Waste Management Biomedical Waste Facility | September 20, 2011 |
| Generator status | Facility address | Date Report Sent |
| SQG | 149 SW Kenyon Street, Seattle | October 11, 2011 |

Inspection Report

Facility Background

Retrofitting of this site began in 2008, but actual operations did not begin until June of this year. This facility has a solid waste facility permit (#PR0080378) from the Seattle-King County Department of Public Health Solid Waste Office to collect, treat, recycle, exchange, store, consolidate, and/or transfer Bio Medical Waste. The permit specifies that "pathological, chemotherapy, and non-hazardous pharmaceuticals wastes may be received at this site only for temporary storage (90 days maximum) in a refrigerated storage trailer until shipped for incineration." Treatment of the biomedical wastes on site is done by steam sterilization (autoclave) process.

Inspection Summary

Daylin Davidson (NWRO), David Keeney (NWRO), Jenny Yoo (NWRO -TR) and Nannette Brooks (SWRO) of Ecology arrived on site at 9 a.m. We met with Yolanda Pon of Seattle King County Department of Public Health, Mike Jeffers of Seattle Public Utilities, and Lydia Eng of King County Industrial Waste. We then met with the facility representatives, Jeff Altman, Regional Environmental Manager, Jeff Daub, District Manager, and Sam and Mitchell Billings, the site operators, for this scheduled visit.

Main Processing Area:

Mr. Altman explained the facility's history and processes. He told us that they currently are running at partial capacity because they only have 20-25 customers so far (a few in Oregon, a few in Idaho, the rest in Washington). They required a contract and a waste acceptance policy (WAP) be in place before accepting waste from customers. They provide special bags to their clients that are heat resistant and do not melt during the autoclave process. (We were able to observe an autoclave process batch that had cooled for about one hour. The photo taken (photo 1) documents that integrity of the bag.) Bagged waste is brought in their trucks back to this facility and the cardboard storage totes are individually bar-coded and weighed on the scale when they are unloaded. A radioactivity meter is located here and any "hot" loads are the responsibility of the generator. The contents of the approved totes are then poured into a larger, wheeled tote that is pushed into the autoclave. Four totes fill the autoclave, which is then run for approximately 28 minutes at 38 psi at 285 degrees F. They currently average six of these batches per week. The steam and water from the autoclave is captured and reused via an air-to-air condenser mounted outside the west wall of the facility. Mr. Altman told us that one batch uses approximately 600 gallons of water, but that about 520 gallons can be reused, so only about 80 gallons of makeup water is needed per batch. We noticed a residue or sediment in the trench under the door of the main autoclave. We also observed liquid dripping from this unit. Mr. Altman further explained that after the autoclave processes is complete and the contents have cooled, the four totes are wheeled over to the compactor where their contents are "pushed" into a 40 foot cargo container mounted on a truck. This is taken to a railcar and is transported by rail to the Columbia Ridge landfill in Oregon.

A mobile autoclave unit is also used in this area to collect international wastes from the airport. Mr. Altman told us that trenches in the floor inside this area capture all liquids from the autoclaves, floor washing, spilled materials, etc and convey them to an underground, three-compartment 660-gallon, oil/water separator vault located outside the north wall of the facility. Per Mr. Altman, this vault primarily serves the purpose of allowing the water to cool before being discharged to the sanitary sewer under a (Minor) Discharge Authorization No. 785-02 from King County Industrial Waste.

Washington State Department of Ecology Hazardous Waste and Toxics Reduction Program

| | | |
|-------------------------|---|---------------------------------------|
| RCRA Site ID # None | Facility name Waste Management Biomedical Waste Facility | Inspection date September 20, 2011 |
| Generator status SQG | Facility address 149 SW Kenyon Street, Seattle | Date Report Sent October 11, 2011 |

When we asked how they ensure that no hazardous wastes are brought to their site mixed in with biomedical waste, Mr. Daub told us that depending on the customer's needs, they conduct audits of their customer's sites to help educate the staff. He indicated that typically "hospitals need more help". He also told us that they do a visual check for disallowed items when they pour the contents of the totes, but admitted that it is impossible to see through the red bags.

We asked about sharps containers and he explained that these are comingled with all the other biomedical wastes at the point of generation. Only one customer segregates the sharps container currently, under a pilot project in which the sharps containers are taken to an out of state destination for recycling.

South Side Wash Rack Area:

Mr. Altman told us that in this area, totes are pressure washed first using a sodium hypochlorite solution and sodium hydroxide solution at a 1:200 dilution, and then rinsed. This water goes to the central drain in this area which has a small sump, which is connected to the vault. Totes are then dried and returned to use. Per Ms. Eng's request, the facility has been doing pH testing of the wash water and found it be around 7.2.

Mr. Altman told us that Bravo Environmental or Emerald Services are contracted to come clean out this small sump and take the contents as a non-hazardous waste. He confirmed that no designation testing had been conducted on the liquids or sediment in the sump. Mr. Altman estimated that approximately 305 gallons of water is discharged to this sump per four hour shift.

North Side Outdoor Area:

Outside the north end of the building we saw the covers for the underground vault. We were told the boiler blow down and condensate also drained to the vault. Mr. Altman said that no water is added to the vault for the purposes of cooling the contents. We asked if the liquids and sediments from this vault had ever been designated and Mr. Altman indicated that they had hired a consultant to conduct testing back in 2008, but that was before the facility began operations (in June this year). He agreed to send us the analysis that he had from 2008.

From this vantage, we observed the air-to-air condenser mounted on the west side of the building. Mr. Daub explained that this unit could re-capture most of the 600 gallons of water needed to run a cycle of the autoclave so only 80-87 gallons of fresh water are used per cycle.



East Side/Front:



The compactor is located here to load the disinfected solid waste into the 40 foot container. We noted that the trench drain under the compactor was only about 4 feet from the storm drain trench surrounding the outside front and south side of the building. No berm or visible slope was present to stop spilled materials from entering the storm trench.



Photo Log



Photographer: Nannette Brooks (SWRO)



Witness: Daylin Davidson



| Area & Description | Photographs |
|---|--|
| <p>#1</p> <p>Main Processing Area</p> <p>Waste in red bags that have been treated inside the autoclave.</p> |  <p>A photograph showing a large, open container lined with a red plastic liner. The container is filled with numerous bright red plastic bags, which are the waste being treated. The date and time stamp in the bottom right corner of the photo reads "09.20.2011 09:07".</p> |
| <p>#2</p> <p>Main Processing Area</p> <p>Liquid observed being released from the open autoclave door to a floor trench</p> |  <p>A photograph showing the interior of an autoclave with its door open. The door is green and is tilted upwards. A liquid is being released from the door into a floor trench. The date and time stamp in the bottom right corner of the photo reads "09.20.2011 09:08".</p> |
| <p>#3</p> <p>Outside Cover Wash Pad (south side of building)</p> <p>Regulated Medical Waste tubs are washed and dried here.</p> |  <p>A photograph showing an outside cover wash pad. A red tub is visible on a green metal frame. The date and time stamp in the bottom right corner of the photo reads "09.20.2011 09:44".</p> |



| Area & Description | Photographs |
|--|---|
| #4 Outside Cover Wash Pad (south side of building) Regulated Medical Waste tub storage. |  A photograph showing several red plastic tubs stacked in a storage area. The tubs are arranged in a row, and some are partially open. The background shows a concrete wall and a doorway. A timestamp in the bottom right corner reads "09.20.2011 08:54". |
| #5 Outside north side of building Access lids to the three-chamber oil water separator (aka "the vault") in the waste water conveyance system. |  A photograph showing three circular access lids on a dark, gravelly ground. The lids are made of metal and are arranged in a row. The background shows a concrete wall and a doorway. A timestamp in the bottom right corner reads "09.20.2011 09:02". |
| #6 Outside north side of building Wall corrosion under a steam outlet pipe. |  A photograph showing a blue corrugated metal wall. The wall appears to be made of steel and shows signs of corrosion, particularly under a steam outlet pipe. The background shows a concrete wall and a doorway. A timestamp in the bottom right corner reads "09.20.2011 09:03". |

| Area & Description | Photographs |
|--|--|
| #7 Outside north side of building Wall corrosion & soil staining under a steam outlet pipe. |  <p>09.20.2011 09:04</p> |
| #8 Outside west side of building Air to Air Condenser unit used to reclaim autoclave wash water. |  <p>09.20.2011 09:05</p> |
| #9 Outside north side of building Wall corrosion under a steam outlet pipe. |  <p>09.20.2011 09:08</p> |

| Area & Description | Photographs |
|--|---|
| <p>#10</p> <p>Outside north side of building</p> <p>We were told this pipe is capped inside the building and is no longer in use.</p> |  <p>A photograph showing the exterior of a building with blue corrugated metal siding. A dark, capped pipe protrudes from the wall. The ground is covered in gravel and some green vegetation. A timestamp in the bottom right corner reads "09.20.2011 09:09".</p> |
| <p>#11</p> <p>Main Processing Area</p> <p>Pictured is the compactor. In the above left corner is a repair to the compactor outer wall.</p> |  <p>An interior photograph of a processing area. The walls are blue. A large piece of machinery, the compactor, is visible. In the upper left corner, there is a repair to the outer wall. A timestamp in the bottom right corner reads "09.20.2011 09:31".</p> |
| <p>#12</p> <p>Main Processing Area</p> <p>Pictured is the compactor. In the above left corner is a repair to the compactor outer wall.</p> |  <p>A photograph showing a different angle of the main processing area. The blue walls and machinery are visible. A repair to the outer wall is seen in the upper left corner. A timestamp in the bottom right corner reads "09.20.2011 09:21".</p> |

| Area & Description | Photographs |
|---|---|
| <p>#13</p> <p>Main Processing Area</p> <p>The trench with a screen covering under the compactor area drains to the vault.</p> |  <p>A photograph showing a trench with a metal screen covering it. The trench is located under a compactor area. The photo is taken from an elevated position looking down into the trench. A timestamp in the bottom right corner reads "09.20.2011 09:24".</p> |
| <p>#14</p> <p>Main Processing Area</p> <p>The steam vent hood above the autoclave.</p> |  <p>A photograph of a large, white, rectangular steam vent hood mounted on a wall. The hood is positioned above an autoclave. The background shows a corrugated metal wall and some industrial equipment. A timestamp in the bottom right corner reads "09.20.2011 09:26".</p> |
| <p>#15</p> <p>Main Processing Area</p> <p>Close up of the trench under the autoclave door.</p> |  <p>A close-up photograph of a trench under an autoclave door. The trench is filled with a dark, viscous liquid. The photo shows the metal structure of the trench and the door. A timestamp in the bottom right corner reads "09.20.2011 09:28".</p> |

| Area & Description | Photographs |
|---|---|
| <p>#16</p> <p>Main Processing Area</p> <p>Close up of the trench under the autoclave door.</p> |  <p>A close-up photograph showing a dark, narrow trench or gap under a large, metallic door. The lighting is dim, highlighting the metallic surfaces and the depth of the trench. A timestamp in the bottom right corner reads "09.20.2011 09:28".</p> |
| <p>#17</p> <p>Outside Covered Wash Pad (south side of building)</p> <p>The covered wash pad area where the Regulated Medical Waste tubs are washed and dried. Note the drain in the center of the cement section – piped to the vault. Trench drains around asphalt section drain to storm.</p> |  <p>A photograph of an outdoor covered wash pad area. The ground is a mix of concrete and asphalt. In the background, there are several red and white tubs, and a white van is parked. The area is enclosed by a metal structure. A timestamp in the bottom right corner reads "09.20.2011 09:51".</p> |
| <p>#18</p> <p>Main Processing Area</p> <p>The unload and scale area. Liquids are reported to be from pre-inspection washing.</p> |  <p>A photograph of an industrial area, likely an unload and scale area. It shows a large, rusted metal structure with various pipes, valves, and a scale mechanism. The ground is concrete. A timestamp in the bottom right corner reads "09.20.2011 09:58".</p> |

| Area & Description | Photographs |
|---|---|
| #19 Main Processing Area |  A photograph showing a large industrial facility. On the left, a large, dark, cylindrical metal tank is visible. In the center, a blue scale is placed on the floor. To the right, there are several cardboard boxes, one of which is labeled 'EP 4'. The floor is concrete and the walls are made of corrugated metal. A timestamp '09.20.2011 09:41' is visible in the bottom right corner of the photo. |
| #20 Main Processing Area Waste transfer area. Waste comes in the cardboard tote where they are weighed on the blue scale. |  A photograph of a cardboard tote sitting on a blue scale. The tote is labeled 'EP CONTAINER'. In the background, there are several yellow tipper devices. The floor is dark and the walls are corrugated metal. A timestamp '09.20.2011 09:42' is visible in the bottom right corner of the photo. |
| #21 Main Processing Area Tote tipper device. Totes are loaded from cardboard totes into yellow tippers for transfer to larger roller totes. |  A photograph of several yellow tipper devices. These are large, funnel-shaped containers used for transferring waste from smaller cardboard totes into larger roller totes. The devices are arranged in a row. A timestamp '09.20.2011 09:42' is visible in the bottom right corner of the photo. |

| Area & Description | Photographs |
|--|---|
| <p>#22</p> <p>Main Processing Area</p> <p>Tote tipper device. Totes are loaded from cardboard totes into yellow tippers for transfer to larger roller totes.</p> |  <p>The photograph shows two yellow, upright, rectangular tote tipper devices. They have a hinged top that is currently open, revealing a flat, yellow tray at the bottom. The devices are situated in an industrial setting, likely a processing area. In the background, a person wearing a white lab coat and a yellow safety vest is partially visible. A timestamp in the bottom right corner of the photo reads '09:20:37 09:42'.</p> |

*Time stamp on all photos is one hour slow.

Exhibit 18

From: [Keeney, David \(ECY\)](#)
To: [Daub, Jeffrey](#)
Subject: RE: Update
Date: Monday, May 14, 2012 11:14:49 AM

Jeff,

Ecology is still working on evaluating the data you provided to determine precisely how it is handled under the dangerous waste regulations. Based on the approval from King County for the discharge, I have no issue with Waste Management resuming biomedical autoclave operations at the Seattle facility. I will be in touch as soon as I can on how this effluent stream fits in with the dangerous waste regulations.

Thanks,

David P. Keeney
Hazardous Waste Compliance Inspector
WA State Department of Ecology, NWRO
Phone (425) 649-7065 Fax (425) 649-7218
dkee461@ecy.wa.gov



To conserve paper please don't print this e-mail unless you really need to.

From: Daub, Jeffrey [mailto:jdaub@wm.com]
Sent: Monday, May 14, 2012 9:02 AM
To: Keeney, David (ECY)
Subject: RE: Update

Dave,

Altman and I spoke to Lydia Eng (King County Waste Water Treatment) on Friday afternoon and because the waste water discharge is in volumes and concentrations that do not pose a health risk, she was fine with the operations.

Jeff Daub

Senior District Manager
Waste Management - Pacific Northwest
Cell (206) 406-3030
jdaub@wm.com

Did you know? Waste Management's renewable energy projects create enough energy to power over 1 million homes. **THINK GREEN® Think Waste Management.**

From: Keeney, David (ECY) [mailto:dkee461@ecy.wa.gov]
Sent: Monday, May 14, 2012 8:55 AM
To: Daub, Jeffrey
Subject: RE: Update

WM000213

Good Morning, Jeff.

I am in the process of working through things. Due to the nature of the situation I have submitted things to several folks at Ecology's headquarters for comment to ensure statewide consistency in dealing with mixed lab data like this. I have conveyed the urgency of the situation to the folks at headquarters and will hopefully hear back from them soon.

Have you gotten a response from King County regarding the discharge permit?

Thanks,

David P. Keeney
Hazardous Waste Compliance Inspector
WA State Department of Ecology, NWRO
Phone (425) 649-7065 Fax (425) 649-7218
dkee461@ecy.wa.gov



To conserve paper please don't print this e-mail unless you really need to.

From: Daub, Jeffrey [mailto:jdaub@wm.com]
Sent: Monday, May 14, 2012 8:44 AM
To: Keeney, David (ECY)
Subject: Update

Dave,

As soon as you have an update, please send me an email.

Thank you,

Jeff Daub
Senior District Manager
Waste Management - Pacific Northwest
Cell (206) 406-3030
jdaub@wm.com

Did you know? Waste Management's renewable energy projects create enough energy to power over 1 million homes. **THINK GREEN® Think Waste Management.**

**Waste Management recycles enough paper every year to save 41 million trees.
Please recycle any printed emails.**

WM000214

Exhibit 19



City of Seattle
Seattle Public Utilities

September 22, 2011

Waste Management – Pacific Northwest
WM - Healthcare Solutions, Inc.
Attn: Jeff Daub
13225 NE 126th Pl
Kirkland, WA 98034-8701

Subject: Environmental Compliance Inspection Results

Dear Mr. Daub:

Thank you for your cooperation during the initial inspection that was conducted at your facility at 149 SW Kenyon St. Inspections of commercial and industrial properties are being conducted as part of the Lower Duwamish Waterway Superfund program in an effort to assist businesses in preventing the discharge of pollutants to the Duwamish waterway via storm drains and combined sewer overflows. SPU is also inspecting businesses to ensure that they are in compliance with the City's Stormwater Code (SMC 22.800 -22.808), which requires all businesses to implement and maintain best management practices to prevent stormwater pollution.

During the inspection, I did not observe any stormwater code violations at your facility. Areas of environmental compliance inspected included industrial waste discharges, stormwater pollutant source control requirements, and general hazardous product storage and disposal practices. Although your operations have a spill plan developed to satisfy SPCC requirements this plan was not readily available at this autoclave facility. It would be best to have a site specific spill response plan for your bio-medical waste and international waste autoclave facility and post it conspicuously for employees to use in an emergency.

SPU appreciates your efforts to prevent pollution discharging to our city waterways. Implementing and maintaining best management practices at your property is the most efficient and cost effective way to prevent pollutants from entering your storm drains, which ultimately discharge into the Duwamish Waterway. An inspector may return to your business in the future to review your pollution prevention practices and relay current and relevant technical information.

More information about the SPU surface water quality program can be found on the SPU web site at [http://www.seattle.gov/util/Services/Drainage & Sewer/index.asp](http://www.seattle.gov/util/Services/Drainage_%20Sewer/index.asp).

If you have any questions or concerns regarding this letter, please contact me at (206) 386-9085 or michael.jeffers@seattle.gov.

Sincerely,

Mike Jeffers
Environmental Compliance Inspector

Ray Hoffman, Director
Seattle Public Utilities
700 5th Avenue, Suite 4900
PO Box 34018
Seattle, WA 98124-4018

Tel (206) 684-5851
Fax (206) 684-4631
TDD (206) 233-7241
ray.hoffman@seattle.gov

<http://www.seattle.gov/util>

An equal employment opportunity, affirmative action employer. Accommodations for people with disabilities provided on request.

WM000695

Exhibit 20_a



City of Seattle – Seattle Public Utilities

Seattle Municipal Tower (SMT)
700 Fifth Avenue, Suite 4900
P.O. Box 34018
Seattle, WA 98124-4018

File Number: 2011-031

Date: December 8, 2011

**SEATTLE PUBLIC UTILITIES
NOTICE OF VIOLATION
AND
ORDER FOR CORRECTIVE ACTION AND PENALTY**

Name: Mr. John Burghese, Site Manager
Waste Management of Washington Inc.

Address: 70 S Alaska St.
Seattle, WA 98134

On November, 17, 2011, Mike Jeffers, SPU Environmental Compliance Inspector, arrived at Waste Management with Ecology Water Quality Inspector Bob Wright. The purpose of the visit was to confirm if stormwater violations were continuing at this site after a previous visit by Ecology showed extensive track out of dirt from this facility entrance/exit. The entrance and exit from this facility is located on S Alaska St and Utah Ave S.

Mr. Wright and Mr. Jeffers both met with Mr. John Burghese, Site Manager Alaska St and Rail Operations Manager. After meeting with Mr. Burghese, it was determined that the facility wheel wash was broken, resulting in the discharge and trackout of turbid water and industrial process water to the public drainage control system. Mr. Wright informed him that this trackout and wastewater discharge were violations of his stormwater permit. Mr. Jeffers informed Mr. Burghese that this discharge from his operations was also a violation of Seattle Stormwater Code and that the discharge must be stopped and the drainage system cleaned to remove contaminants.

Mr. Burghese returned to his office to hire a spill response contractor to clean the catch basins. He had already ordered his rotary brush sweeper to come out and push the track-out material back onto the property and out of the entrance area to augment two manual broom sweepers. He shut down operations to alleviate the overflow from the wheel wash. Wastewater continued to flow off of the property and into the storm drain for some time even though the wheel wash was shut down. Within thirty minutes a contracted vacuor truck arrived and started cleaning the impacted catch basins and drainage lines.

CODE VIOLATION:

- SMC 22.802.020.A Prohibited Discharges
The following common substances are prohibited to enter, either directly or indirectly, a public drainage systems, a private drainage system, or a receiving water within or contiguous to Seattle city limits, including but not limited to when entering via a service drain, overland flow, or as a result of a spill or deliberate dumping: ...
... 11. Dirt,
... 20. Industrial process wastewater,

PENALTY:

Pursuant to SMC 22.808.050, the penalty for this violation has been assessed at \$1000. This penalty is due within 30 days to the address provided on the attached invoice.

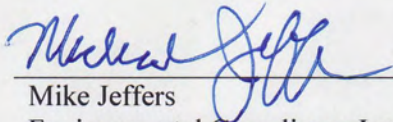

Mike Jeffers
Environmental Compliance Inspector

(206) 386-9085

Phone Number

michael.jeffers@seattle.gov

Email

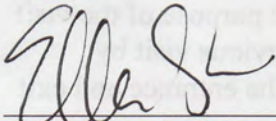

Ellen Stewart, Supervisor

(206) 615-0023

Phone Number

ellen.stewart@seattle.gov

Email

SEE REVERSE SIDE FOR INSTRUCTIONS

NOTICE OF VIOLATION AND ORDER CODE AUTHORITY
Stormwater Code Enforcement - Ch. 22.800-22.808 SMC

- 1) If you have questions or don't understand the violation or what is necessary to correct it, contact Seattle Public Utilities. You may call the Inspector whose name, phone number and email are on this notice.
- 2) The Notice of Violation and Order shall be final and not subject to further appeal unless an aggrieved party requests in writing a review by the Director within **ten (10) days** after service of the Notice of Violation and Order. When the last day of the period so computed is a Saturday, Sunday or federal or City holiday, the period shall run until 5:00 p.m. on the next business day. (SMC 22.808.030.D).

Send request to:

Ellen Stewart
Seattle Public Utilities
700 5th Avenue, Suite 4900
POB 34018
Seattle, WA 98124-4018

- 3) If a responsible party fails to correct a violation or pay a penalty as required by a Notice of Violation, or fails to comply with a Director's order, the Director shall refer the matter to the City Attorney's Office for civil or criminal enforcement action (SMC 22.808.030.E).
- 4) In addition to penalties, these violations and failure to complete the corrective work may result in responsible party liability for City costs of corrective action and abatement, investigation costs, costs to correct the violations or other cost expenses, and loss or damage incurred by the City, plus a surcharge of 15% for administrative costs, as set forth in SMC 22.808.050 -.060 and -.070.

NOTICE OF VIOLATION AND ORDER PENALTY PAYMENT

See attached invoice for payment instructions.



Seattle Public Utilities
 PO Box 34018
 Seattle, WA 98124 - 4018
 (206) 615-1449

INVOICE

Invoice #: W0073396
 Invoice Date: 12/08/2011
 Due Date: 01/07/2012
 Reference #: NOV 2011-031

Customer: SPU002343

AMOUNT DUE: \$ 1,000.00 USD

WASTE MANAGEMENT OF WA INC
 ATTN: JOHN BURGHESE
 7201 W MARGINAL WAY SW
 SEATTLE WA 98106
 United States

Amount Remitted

Make checks payable to the Seattle Public Utilities and return this portion of the invoice with payment to the above address.
 Late payments are subject to an interest penalty of 12% per annum.



Seattle Public Utilities
 PO Box 34018
 Seattle, WA 98124 - 4018
 (206) 615-1449

INVOICE

Invoice #: W0073396
 Invoice Date: 12/08/2011
 Payment Terms: Net 30
 Due Date: 01/07/2012
 Reference #: NOV 2011-031

| Description | Amount |
|-------------|--------|
|-------------|--------|

PENALTY PAYMENT 1,000.00

STORMWATER CODE PENALTY
 PENALTY PAYMENT FOR NOV 2011-031

Subtotal: 1,000.00

| GL Acct. | Dept. | Prod. | Oper Unit | Dist | Amount | Vertex Tax Code |
|----------|-------|-------|-----------|------|--------|-----------------|
| | | | | | | |
| | | | | | | |
| | | | | | | |
| | | | | | | |
| | | | | | | |
| | | | | | | |
| | | | | | | |
| | | | | | | |
| | | | | | | |

Site Approval _____ District Manager Approval _____

AMOUNT DUE: \$ 1,000.00

Exhibit 20_b



Seattle Public Utilities
 PO Box 34018
 Seattle, WA 98124 - 4018
 (206) 615-1449

INVOICE

Invoice #: W0073396
 Invoice Date: 12/08/2011
 Due Date: 01/07/2012
 Reference #: NOV 2011-031

Customer: SPU002343

AMOUNT DUE: \$ 1,000.00 USD

WASTE MANAGEMENT OF WA INC
 ATTN: JOHN BURGHESE
 7201 W MARGINAL WAY SW
 SEATTLE WA 98106
 United States

Amount Remitted

Make checks payable to the Seattle Public Utilities and return this portion of the invoice with payment to the above address.
 Late payments are subject to an interest penalty of 12% per annum.



Seattle Public Utilities
 PO Box 34018
 Seattle, WA 98124 - 4018
 (206) 615-1449

INVOICE

Invoice #: W0073396
 Invoice Date: 12/08/2011
 Payment Terms: Net 30
 Due Date: 01/07/2012
 Reference #: NOV 2011-031

| Description | Amount |
|-------------|--------|
|-------------|--------|

PENALTY PAYMENT 1,000.00

STORMWATER CODE PENALTY
 PENALTY PAYMENT FOR NOV 2011-031

Subtotal: 1,000.00

| GL Acct. | Dept. | Prod. | Oper Unit | Dist | Amount | Vertex Tax Code |
|----------|-------|-------|-----------|------|--------|-----------------|
| | | | | | | |
| | | | | | | |
| | | | | | | |
| | | | | | | |
| | | | | | | |
| | | | | | | |
| | | | | | | |
| | | | | | | |
| | | | | | | |

Site Approval _____ District Manager Approval _____

AMOUNT DUE: \$ 1,000.00

Exhibit 21



STATE OF WASHINGTON
DEPARTMENT OF ECOLOGY

Northwest Regional Office, 3190 - 160th Ave S.E. • Bellevue, Washington 98008-5452 • (425) 649-7000

August 30, 2012

Mr. Matthew Stern
Director of Recycling Operations
Waste Management – Pacific NW
5903 63rd Avenue Ct. NW
Gig Harbor, WA 98335

| | |
|---------------------------------|---|
| Amended Order Docket No. | 9479 |
| Order Docket No. | 9274 |
| Site Location | Waste Management – Glacier 32300 148 th Avenue SE Auburn, WA |

Re: Amended Administrative Order

Dear Mr. Stern:

The Department of Ecology has issued the enclosed amended Administrative Order requiring Waste Management – Glacier to comply with:

- Chapter 90.48 Revised Code of Washington (RCW) – Water Pollution Control.

If you have questions please contact Tracie Walters at 425-649-4484 twal461@ecy.wa.gov.

Sincerely,

Kevin C. Fitzpatrick
Water Quality Section Manager
Department of Ecology
Northwest Regional Office

Enclosure: Amended Administrative Order Docket No. 9479

By certified mail no. 7008 0150 0003 7591 7946



**STATE OF WASHINGTON
DEPARTMENT OF ECOLOGY**

| | | |
|-------------------------------|---|------------------------|
| IN THE MATTER OF AN |) | AMENDED ADMINISTRATIVE |
| ADMENDED ADMINISTRATIVE ORDER |) | ORDER DOCKET NO. 9479 |
| AGAINST |) | |
| Waste Management – Glacier |) | ADMINISTRATIVE ORDER |
| Matthew Stern |) | DOCKET NO. 9274 |

To: Matthew Stern
Director of Recycling Operations
Waste Management – Pacific Northwest
5903 63rd Avenue Ct. NW
Gig Harbor, WA 98335

| | |
|--------------------------|---|
| Amended Order Docket No. | 9479 |
| Order Docket No. | 9274 |
| Site Location | 32300 148 th Avenue SE, Auburn, WA |

The Department of Ecology (Ecology) has issued this amended Administrative Order (Order) Docket No. 9479 to amend Order Docket No. 9274 dated June 20, 2012, issued to Matthew Stern, Waste Management – Pacific Northwest.

This Order describes the corrective actions required at the location known as:

Waste Management – Glacier
32300 148th Avenue SE
Auburn, WA

ADMINISTRATIVE ORDER AMENDMENTS

Actions one and two on page two of the Order No. 9274, dated June 28, 2012, states:

Install structural or treatment Best Management Practices that will minimize the amount of sediment leaving the site on or before July 30, 2012.

Install structural or treatment Best Management Practices that prevents wheel wash water from entering waters of the state on or before July 30, 2012.

Is hereby amended as follows:

By November 1, 2012, implement all corrective actions and associated timelines listed in correspondence dated August 17, 2012, as follows:

| | Action | Work/Activities Needed | Completion Target Date |
|---|---|---|---|
| 1 | Add Wheel Wash System | Spec, Acquire, Site Preparation and Installation | 11/1/2012 |
| 2 | Install Rumble Grating Locations: a. Entry to Outbound Scale b. Exit from Outbound Scale c. Exit to Wheel Wash d. Bypass Lane | Acquire, Surface Preparation and Installation. | 11/1/2012 In conjunction with Wheel Wash |
| 3 | Establish winter-weather traffic route to utilize existing pavement by trailer tipper area and back of building. | Relocate existing wood and residual piles; Install barriers and traffic direction markings. | 10/1/2012 – route clear; Switch over when weather dictates. |
| 4 | Facility Entrance: Enhance sheet flow control to divert rainwater to infiltration area. | Complete installation of drainage ditches on the side of entrance draining back on to site. | 9/15/12 |

No other condition or requirement of Order Docket No. 9274 is hereby affected by this amendment.

ELIGIBILITY FOR PAPERWORK VIOLATION WAIVER AND OPPORTUNITY TO CORRECT

Under RCW 34.05.110, small businesses are eligible for a waiver of a first-time paperwork violation and an opportunity to correct other violations. We have made no determination as to whether you meet the definition of a “small business” under this section. However, we have determined that the requirements of RCW 34.05.110 do not apply to the violation(s) due to a conflict with federal law or program requirements, including federal requirements that are a prescribed condition to the allocation of federal funds to the state.

FAILURE TO COMPLY WITH THIS ORDER

Failure to comply with this Order may result in the issuance of civil penalties or other actions, whether administrative or judicial, to enforce the terms of this Order.

YOUR RIGHT TO APPEAL

You have a right to appeal this Order to the Pollution Control Hearing Board (PCHB) within 30 days of the date of receipt of this Order. The appeal process is governed by Chapter 43.21B RCW and Chapter 371-08 WAC. “Date of receipt” is defined in RCW 43.21B.001(2).

To appeal you must do both of the following within 30 days of the date of receipt of this Order:

- File your appeal and a copy of this Order with the PCHB (see addresses below). Filing means actual receipt by the PCHB during regular business hours.
- Serve a copy of your appeal and this Order on Ecology in paper form – by mail or in person (see addresses below). E-mail is not accepted.

You must also comply with other applicable requirements in Chapter 43.21B RCW and Chapter 371-08 WAC.

Your appeal alone will not stay the effectiveness of this Order. Stay requests must be submitted in accordance with RCW 43.21B.320.

ADDRESS AND LOCATION INFORMATION

| Street Addresses | Mailing Addresses |
|--|---|
| Department of Ecology Attn: Appeals Processing Desk 300 Desmond Drive SE Lacey, WA 98503 | Department of Ecology Attn: Appeals Processing Desk PO Box 47608 Olympia, WA 98504-7608 |
| Pollution Control Hearings Board 1111 Israel Road SW STE 301 Tumwater, WA 98501 | Pollution Control Hearings Board PO Box 40903 Olympia, WA 98504-0903 |

CONTACT INFORMATION

Please direct all questions about this Order to:

Tracie Walters
Department of Ecology
Northwest Regional Office
3190 160th Avenue SE
Bellevue, WA 98008-5452
Phone: 425-649-4484
Email: twal461@ecy.wa.gov

MORE INFORMATION

- Pollution Control Hearings Board Website**
www.eho.wa.gov/Boards_PCHB.aspx
- Chapter 43.21B RCW - Environmental and Land Use Hearings Office – Pollution Control Hearings Board**
<http://apps.leg.wa.gov/RCW/default.aspx?cite=43.21B>
- Chapter 371-08 WAC – Practice and Procedure**
<http://apps.leg.wa.gov/WAC/default.aspx?cite=371-08>
- Chapter 34.05 RCW – Administrative Procedure Act**
<http://apps.leg.wa.gov/RCW/default.aspx?cite=34.05>
- Laws:** www.ecy.wa.gov/laws-rules/ecyrcw.html
- Rules:** www.ecy.wa.gov/laws-rules/ecywac.html

SIGNATURE

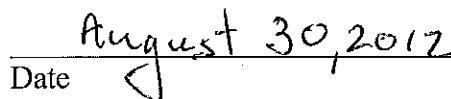

Kevin C. Fitzpatrick
Water Quality Section Manager

August 30, 2012
Date 

- 3) Discharging Pollutants Without a Permit Authorized under RCW 90.48.160, 90.48.180, or 90.48.260 through 90.48.262.
- 4) Violation of the Terms of a Regulatory Order or other provisions of RCW 90.48.
- 5) Agricultural Discharges, RCW 90.48.450. Has consideration been given to the effect of the action on conversion of agricultural to nonagricultural uses? _____. If yes, what attempts have been made to minimize the possibility of such conversion? (Water Quality Program Policy #1-05)
- 6) Other

V. Name of Watercourse Involved:

City of Auburn MS4

VI. Narrative of Incident:

This facility recycles construction waste; however, it is not covered under the Industrial Stormwater General Permit because there are no surface water discharges.

On June 28, 2012, Order No. 9274 was issued to Waste Management (WM) to eliminate the tracking of sediment off-site and to prevent the potential discharge of wheel wash water to the City of Auburn's municipal storm system. WM sent a request to Ecology to amend Order No. 9274 to allow sufficient time to complete their plans to correct the problems.

This amendment of Order # 9274 allows sufficient time to implement the corrective actions listed in correspondence dated August 17, 2012.

VII. Technical Assistance Efforts to Resolve Violation:

VIII. Evidence Obtained:

- Samples, Lab. Report No.
- Pictures
- Video Tape
- Witness Statements
- Documents
- Maps
- Other: _____

ENDORSEMENTS

The following actions are recommended to resolve this matter:

Concur with this amendment to
Order 9274

Greg Stegman *Gregory P. Stegman*
Water Quality Acting Unit Supervisor Date 8-29-2012

Concurrence with recommended action:

Concur on Amendment
to order

Kevin C. Fitzpatrick *Kevin C. Fitzpatrick*
Water Quality Section Manager Date 8-30-2012