

**PART X - NONREGULATED/REGULATED ALLOCATION  
2111 LAND & 2121 BUILDING  
FOR THE STUDY YEAR ENDED DECEMBER 31, 2008**

	<u>DIMENSIONS</u>	<u>TOTAL FOOTAGE</u>	<u>NON-REG FOOTAGE</u>	<u>REGULATED FOOTAGE</u>
<b><u>MANSON CENTRAL OFFICE</u></b>				
Generator	8' x 10'	80.00	4.00	76.00
COE Equipment	13'6" x 14'8"	198.05	9.90	188.14
Building	32' x 28'	697.96	27.92	670.04
				0.00
TOTAL SQUARE FEET		976.00	41.82	934.18
DISTRIBUTION		1.000000	0.042849	0.957151
ALLOCATION ADJ BAL PER BOOKS:				
Land	2210	136,660	5,856	130,804
Building	2210	340,183	14,576	325,607

PAYROLL HOURS -

(1) Executive Distribution	2810	1.000000	0.050000	0.950000
(2) Total Commercial Office Payroll Distr	2810	1.000000	0.030000	0.970000
(3) Total Plant Payroll	2810	1.000000	0.050000	0.950000
(4) Total Company Distribution	2810	1.000000	0.040000	0.960000

	<u>TOTAL</u>	<u>NON-REG</u>	<u>REGULATED</u>
TOTAL ALLOCATED LAND	136,660	5,856	130,804
TOTAL ALLOCATED BUILDING	340,183	14,576	325,607

24

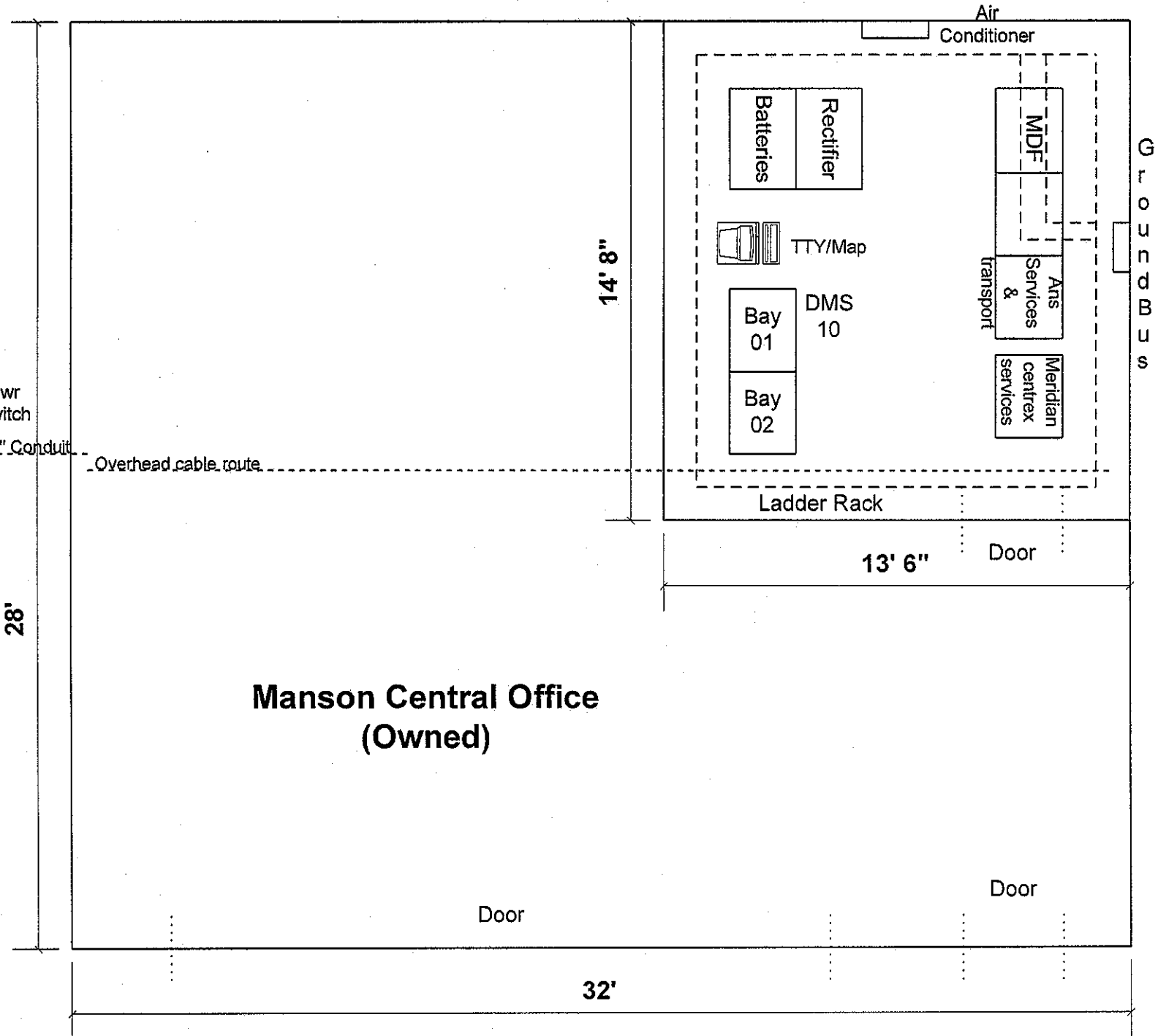
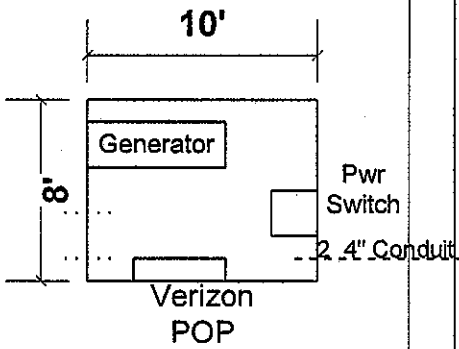

211