

2021 Natural Gas Integrated Resource Plan Appendices

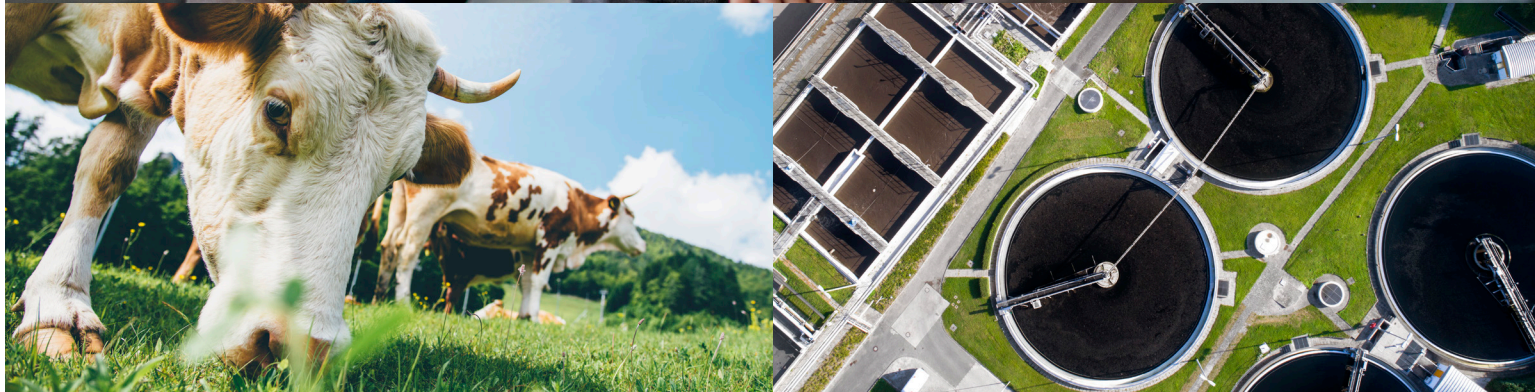

Safe Harbor Statement

This document contains forward-looking statements. Such statements are subject to a variety of risks, uncertainties and other factors, most of which are beyond the Company's control, and many of which could have a significant impact on the Company's operations, results of operations and financial condition, and could cause actual results to differ materially from those anticipated.

For a further discussion of these factors and other important factors, please refer to the Company's reports filed with the Securities and Exchange Commission. The forward-looking statements contained in this document speak only as of the date hereof. The Company undertakes no obligation to update any forward-looking statement or statements to reflect events or circumstances that occur after the date on which such statement is made or to reflect the occurrence of unanticipated events. New risks, uncertainties and other factors emerge from time to time, and it is not possible for management to predict all of such factors, nor can it assess the impact of each such factor on the Company's business or the extent to which any such factor, or combination of factors, may cause actual results to differ materially from those contained in any forward-looking statement.

TABLE OF CONTENTS: APPENDICES

Appendix	0.1	TAC Member List.....	Page 1
	0.2	Comments and Responses to the 2021 IRP.....	2
Appendix	1.1	Avista Corporation 2021 Natural Gas IRP Work Plan	9
	1.2	IRP Guideline Compliance Summaries	12
Appendix	2.1	Economic Outlook and Customer Count Forecast	27
	2.2	Customer Forecasts by Region.....	45
	2.3	Demand Coefficient Calculations	87
	2.4	Heating Degree Day Data.....	91
	2.5	Demand Sensitivities and Demand Scenarios.....	101
	2.6	Demand Forecast Sensitivities and Scenarios Descriptions.....	103
	2.7	Annual Demand, Avg Day & Peak Day Demand (Net of DSM).....	108
	2.8	Demand Before and After DSM.....	112
	2.9	Detailed Demand Data	117
Appendix	3.1	Avista Gas CPA Report Final.....	127
	3.2	Environmental Externalities	131
Appendix	4.1	Current Transportation/Storage Rates and Assumptions	225
Appendix	5.1	Renewable Resource Development and Procurement Tree.....	227
Appendix	6.1	Monthly Price Data by Basin.....	233
	6.2	Weighted Average Cost of Capital	242
	6.3	Supply Side Resource Options	243
	6.4	Avoided Costs Detail	244
Appendix	7.1	High Growth Case	265
	7.2	Peak Day Demand Table	267
Appendix	8.1	Distribution System Modeling.....	275

Appendix	8.2	Distribution within the IRP.....	279
		TAC Meeting #1.....	281
		TAC Meeting #2	379
		TAC Meeting #2.5.....	481
		TAC Meeting #3	527
		TAC Meeting #4	672

APPENDIX 0.1: TAC MEMBER LIST

Organization	Representatives	
Applied Energy Group	Kenneth Walter	
Avista	Terrence Browne Jody Morehouse Amanda Ghering Tom Pardee Ryan Finesilver Michael Brutocao Grant Forsyth Jason Thackston James Gall Jaime Majure Justin Dorr Michael Whitby John Lyons Shawn Bonfield Lisa McGarity Jeff Webb	
Biomethane, LLC	Kathlyn Kinney	
Cascade Natural Gas Company	Ashton Davis Brian Robertson Mark Sellers- Vaughn	
Citizens Utility Board of Oregon	Sudeshna Pal Will Gehrke	
Energy Trust of Oregon	Peter Schaffer Spencer Ted Light Moersfelder	
Fortis	Ken Ross	
Idaho Conservation League	Dainee Gibson- Webb	
Idaho Public Utility Commission	Donn English Kevin Keyt Terri Carlock Mike Louis Joseph Terry Rick Keller	
Intermountain Gas	Raycee Thompson Lori Blattner Dave Swenson	
Northwest Energy Coalition	Amy Wheelless	
Northwest Gas Association	Dan Kirschner	
Northwest Natural Gas	Tammy Linver	

Northwest Power and Conservation Council	Steve Simmons	
Oregon Public Utility Commission	Anna Kim	Kim Herb
Washington State Department of Commerce	Peter Moulton Chuck Murray	Greg Nothstein
Washington State Office of the Attorney General	Shay Bauman Chuck Murray	Corey J Dahl
Washington Utilities and Transportation Commission	Jennifer Snyder Andrew Rector	Deborah Reynolds Steve Johnson

APPENDIX 0.2: COMMENTS AND RESPONSES TO 2021 DRAFT INTEGRATED RESOURCE PLAN

The following table summarizes the significant comments on our DRAFT as submitted by TAC members and Avista's responses. This IRP produced reduced forecasted demand scenarios and no near term resource needs even in our most robust demand scenario. We appreciate the time and effort invested by all our TAC members throughout the IRP process. Many good suggestions have been made and we have incorporated those that enhance the document.

Document Reference	Comment / Question	Avista Response
Chapter 5	For upstream methane emissions, Avista uses a global warming potential (GWP) factor that was calculated based on the International Panel on Climate Change's Assessment Report 5 (IPCC AR5), which Staff prefers over older analyses. Avista uses the upstream methane leakage factor of 0.77 percent for Canadian natural gas, and uses 1.0 percent for the U.S. Rockies natural gas factor. Given that this U.S. Rockies natural gas emissions factor is significantly lower than any of the factors analyzed by the NWPCC in its analysis of upstream natural gas emissions, Staff recommends the Final IRP explain why the factor is appropriate.	Added supplemental language to Chapter 5
Chapter 7	Consider effects of policy trends towards electrification on both the electric and natural gas systems.	Included supplemental language

Chapter 2	Explain the new design day methodology, providing a more detailed narrative.	Updated within Chapter 2
Chapter 2	Further explain why the new design day standard is now the most appropriate one.	Updated within Chapter 2
Chapter 9	Explore the feasibility of using projected future weather conditions in its design day methodology, rather than relying exclusively on historic data.	added to Action Plan
Appendix 7.2	Include details of RNG cost assumptions in the appendices.	Included in Appendix 7.2
Appendix 7.2	Use any up-to-date cost data that is available to model potential RNG resources.	Avista will use the most recent data available where details are verified, reasonable and sufficient enough for cost determination in all resources
Avista 2021 Electric IRP	Avista's Draft 2021 IRP, p11, provides some explanation for factors that could drive future natural gas demand. While Avista does not anticipate any increase in demand from the traditional residential and commercial customer classes, the Company expects growing demand from electric utilities in terms of natural gas back up for solar and wind technologies. CUB is aware that electric utilities serving the Pacific Northwest like, Portland General Electric and PacifiCorp do not have plans to build new gas plants in the long-term. Idaho Power targets for 100% clean energy by 2045. BC Hydro's Clean Power 2040 mandate includes reduction of GHG emissions through clean electricity. CUB would therefore like to see some discussion in the IRP that could substantiate the claim that electric utilities in the Pacific Northwest region are increasingly becoming reliant on gas plants as backups for their renewable generation resources.	Please refer to the Avista 2021 Electric IRP for peaking needs from natural gas plants as summarized in its Preferred Resource Strategy (PRS). The Wood Mackenzie material shown during TAC 2 on August 6, 2020 will provide a high level summary of expected need in the Pacific Northwest, which despite the massive expected buildout of renewable resources, less than half of the natural gas leaves the forecast. On a national level the forecast for the next 20 years remains mostly unchanged in spite of the new electric clean resources. In this case, growing demand does not infer new natural gas plants, just continued demand to meet electric capacity requirements.
Chapter 2, 5 & 7	CUB realizes that Carbon price sensitivities are designed around Oregon and Washington's carbon policy futures as Idaho does not contemplate having a carbon policy in near future. Hence Avista assumes a carbon cost of \$0 for Idaho and other carbon price ranges for Oregon and Washington. CUB suggests that for a long-term planning purpose, Avista should look at a price range for Idaho with a lower limit of \$0 and set a positive dollar amount as upper limit, like it has for Oregon and Washington. CUB would like to cite Idaho Power's 2019 IRP in which the utility considers four carbon cost scenarios, namely,	Chapter 2 contains the sensitivities to a high, expected and low price as compared to the reference case for all jurisdictions. The expected carbon price considers any known policy or direction by state or federal entities that may help indicate a carbon price. In the event there is no policy, like Idaho, formulating a potential price indicator is problematic leading Avista to measure the bounds for risk vs. a specific policy as done through the

		scenarios of high growth and low prices and low growth and high prices. Electric utilities can use shadow pricing or inferred pricing to determine when plants are still cost effective. Natural gas, mostly, uses the single fossil commodity to determine demand. Avista will continue to look for ways to value carbon and include where appropriate.
Chapter 2, 5, 7	Zero Cost – no state or federal tax or fee on carbon emissions),	A low price of carbon of \$0 is assumed for all 3 jurisdictions in the High Growth and Low Prices case to measure no carbon policy.
Chapter 2, 5, 7	Planning Carbon – Based on Wood Mckenzie’s forecasts, starting with \$2/ton in 2028 and goes up to \$22/ton by the end of the planning period,	A Wood Mackenzie carbon assumption was put in place to measure Oregon’s cap and reduce future
Chapter 2, 5, 7	Generational Carbon – Based on EPA’s estimated of social cost of carbon, starting at \$55.73/ton starting in 2020 and increasing to \$101.16/ton by the end of the planning period, and,	This is assumed for WA in the Expected Case
Chapter 2, 5, 7	High Carbon – Based on California Energy Commission’s Integrated Energy Policy Report only for federal programs. Carbon costs under this scenario are assumed to start at \$28.65/ton in 2022 increasing to \$107.87 by the end of the IRP planning horizon. CUB believes using a carbon price range for Idaho will address local, state and federal environment policy related uncertainties for the system as a whole for the planning period.	high carbon costs are included for all jurisdictions to measure the upper limits of carbon prices in the Low Growth and High Prices
Chapter 7	Avista’s Electric IRP includes a natural gas to electricity switching scenario. CUB is wondering why this scenario analysis was not also a part of the natural gas IRP. Recently there have been proposals to phase out gas space and water heating in Washington state. Around forty communities in California have imposed a ban on natural gas heating in new buildings. Avista’s service territory in Southern Oregon is well suited in terms of climate for electrification of heating load. CUB suggests that Avista explore a No Growth scenario for its long-term demand forecast.	A write up is included in Chapter 7. Avista will explore a no growth scenario in the 2023 Avista Natural Gas IRP

Chapter 7	Staff is particularly interested in understanding how different RNG resources were compared for selection in the alternate scenario.	Resources were compared against all resource modeled options which can be viewed in Chapter 7. The options account for all estimated costs to build and maintain the facility and account for the cost of carbon based on the carbon intensity savings by source
Chapter 8	With regard to demand response (Guideline 7), the Company mentions a single project on page 165. Staff would like to see more information about demand response as a demand-side option in the final IRP, both as a system resource and its potential to offset distribution upgrades.	The high pressure projects mentioned on page 165 were identified after comprehensive load study analyses. Each analysis uses 18-24 months of historical customer billing history, so any DSM or energy efficiency measures adopted by customers are reflected in the loads of the analysis. The projects listed reflect current shortfalls on the distribution system. These shortfalls or deficiencies are also too large to be eliminated or even mitigated by DSM or energy efficiency measures. Since most of these projects will be completed over more than one year, Avista will use subsequent load studies to determine if there is a change in the necessity of a project, and then revise or defer accordingly.
Chapter 5	Regarding Environmental Costs (Guideline 8), Staff appreciates the Company's analysis of a portfolio under the Carbon Reduction scenario, and the Company's consideration of creative solutions to compete as a buyer with California's Low Carbon Fuel Standard market. Staff has questions about the assumptions leading to a portfolio of all dairy RNG and will like to see more discussion about how realistic that portfolio is, considering both total accumulation and the timing of additions over 20 years.	Unlike WWTP and landfills, for example, the ability to move livestock and create the product of methane capture seems reasonable. The quantity of these products supply needed is high. The overall potential of this is unknown and so based on the plan to go after the next cheapest resource the product potentials will be better known once carbon pricing, targets and deadlines are clear. This is mostly illustrative in nature and future potential must be estimated by state to have a realistic guideline in place for obtaining these goals.

Chapter 5	In addition to the carbon reduction alternate portfolio, Staff will also consider whether the preferred portfolio and action plan are consistent with Oregon policies. Staff acknowledges that the Company is awaiting additional guidance on how to implement EO 20-04 and understands the Company is prepared to comply by guidance provided, however Staff looks forward to understanding the extent to which the preferred portfolio is consistent with current Oregon policy, including EO 20-04. Further, Staff is preparing to engage with stakeholders on the implementation feasibility and impact of the IRP related activities identified in OPUC EO 20-04 work plan section 1.1. Staff suggests that the company be familiar with this section and be prepared to discuss metrics the Company could provide to track and forecast GHG emissions and strategies to reduce emissions to be compliant with EO 20-04.	The company is engaged in dialogue and meetings surrounding the effort around EO 20-04 and will implement the necessary strategies to reduce emissions.
Chapter 5, 6, 7	With regards to Guideline 10 (Multi-State Utilities), Staff also has questions about how policies across states interact, particularly for RNG. Staff would like to understand the assumptions the Company is using regarding the interaction of RNG policies in Washington and Oregon, and any system-wide strategies being considered.	Resources are solved on a system basis for least cost supply. In the case where Oregon and Washington may both be requiring in state emissions reduction supply sources, Avista modeled these resources directly into the demand zones. This will also help to correctly allocate costs by jurisdiction
Chapter 2, 5, 6, 7	1. Staff made a number of recommendations for potential improvements to the demand forecast. Staff has identified this topic as a key area of focus, particularly in terms of forecasted customer counts and usage per customer. Many of the recommendations relate to improving the modeling of potential carbon policy. For example, although the Company describes on page 11 that “Avista does not anticipate traditional residential and commercial customers will provide increased growth in demand,” even in its low growth scenario, the Company is forecasting	A scenario with reduced demand could be the carbon reduction scenario in the 2021 natural gas IRP. In future IRP's we will consider a declining customer growth scenario. The Low Growth & High Prices scenarios is the best indicator for where Avista currently sees a reduced customer set paired with DSM to offset demand. The Carbon Reduction was included for our Washington service territory with the results and demand loss summarized in Chapter 7. If a similar load loss to electrification were to occur in Oregon, the impact to Avista would strictly be a loss of natural gas demand. The impacts to local electric utilities would need to be quantified by the utilities in each

		of these service areas. The costs to run natural gas service for those remaining customers would be held by fewer and fewer customers meaning their rates would continue to go up.
Chapter 2 – Appendix 2.6	2. Staff also recommended that the Company explore a large-scale supply interruption scenario, and the role of storage in such a situation. This scenario does not appear to be addressed in the draft IRP.	A large scale supply interruption and its impacts to Avista's natural gas system can be seen in Chapter 2. In the cases of a 100% loss of supply or even 50% loss of supply at AECO, JP, SUMAS, or Rockies trading points puts an unserved in the first or second year of planning. Based on these sensitivities it became evident as to the extreme predictions and outcomes of these supply basin outages, so Avista chose not to run a specified scenario.
Chapter 8	Staff is interested in better understanding the lack of anticipated distribution system upgrades. Staff would like to learn more about the certainty of this prediction and what sorts of upgrades the Company is excluding (i.e., is the Company completely foregoing all distribution investments for the next two years, or does the exclusion of distribution projects in the Company's IRP reflect a lack of larger investments?) the Company should include information the Company relied upon to come to this conclusion in its IRP filing.	Please see Chapter 8 Table 8.2. Also, The city gate station projects in Table 8.2 are periodically reevaluated to determine if upgrades need to be accelerated or delayed. Those assigned a TBD year have relatively small capacity constraints, and thus will be monitored. There are no plans to rebuild or upgrade these city gate stations at this time.
Chapter 5, 6, 7	Staff is interested in the interaction between resources, policies, and plans between the Company's Washington and Oregon territories.	Carbon Reduction scenario for specifics on the interaction between policies, resources and plans between our WA and OR territories

APPENDIX 1.1: AVISTA CORPORATION 2021 NATURAL GAS INTEGRATED RESOURCE PLAN WORK PLAN

IRP WORK PLAN REQUIREMENTS

Section 480-90-238 (4), of the natural gas Integrated Resource Plan (“IRP”) rules, specify requirements for the IRP Work Plan:

Not later than twelve months prior to the due date of a plan, the utility must provide a work plan for informal commission review. The work plan must outline the content of the integrated resource plan to be developed by the utility and the method for assessing potential resources.

Additionally, Section 480-90-238 (5) of the WAC states:

The work plan must outline the timing and extent of public participation.

OVERVIEW

This Work Plan outlines the process Avista will follow to complete its 2023 Natural Gas IRP by April 1, 2023. Avista uses a public process to obtain technical expertise and guidance throughout the planning period via Technical Advisory Committee (TAC) meetings. The TAC will be providing input into assumptions, scenarios, and modeling techniques.

PROCESS

The 2021 IRP process will be similar to that used to produce the previously published plan. Avista will use SENDOUT® (a PC based linear programming model widely used to solve natural gas supply and transportation optimization questions) to develop the risk adjusted least-cost resource mix for the 20 year planning period.

This plan will continue to include demand analysis, demand side management and avoided cost determination, existing and potential supply-side resource analysis, resource integration and alternative sensitivities and scenario analysis.

Additionally, Avista intends to incorporate action plan items identified in the 2021 Natural Gas IRP including more detailed demand analysis regarding use per customer, demand side management results and possible price elastic responses to evolving economic conditions, an updated assessment of conservation potential in our service territories, consideration of alternate forecasting methodologies, and the changing landscape of natural gas supply (i.e. shale gas, Canadian exports, and US LNG exports) and its implications to the planning process. Further details about Avista’s process for determining the risk adjusted least-cost resource mix is shown in Exhibit 1.

TIMELINE

The following is Avista's 2021 Natural Gas IRP timeline:

TAC 1: Wednesday, June 17, 2020: TAC meeting expectations, 2020 IRP process and schedule, energy efficiency update, actions from 2018 IRP, and a Winter of 2018-2019 review. Procurement Plan and Resource Optimization benefits. fugitive Emissions, Weather Analysis, Weather Planning Standard

TAC 2 (Dual Meeting with Power side): Thursday, August 6, 2020: Market Analysis, Price Forecasts, Cost Of Carbon, demand forecasts and CPA results from AEG, Environmental Policies

TAC 3: Wednesday, September 30, 2020: Distribution, Avista's current supply-side resources overview, supply side resource options, renewable resources, SENDOUT overview, sensitivities and portfolio selection modeling.

TAC 4: Wednesday, November 18, 2020: Review assumptions and action items, final modeling results, portfolio risk analysis and 2020 Action Plan.

TAC 5: February 2021: TAC final review meeting (if necessary)

Avista's TENTATIVE 2023 Natural Gas IRP timeline:

Major Milestone	Date	Topics
TAC 1	Nov-2022	Use per customer, Policy, 2021 Action Item Review, price elasticity
TAC 2	Mar-2022	Customer Forecast, price forecast
TAC 3	Apr-2022	sensitivities, distribution, model overview
TAC 4	Jun-2022	Renewable Resources, Supply Side Resources, Demand Side Resources (CPA)
TAC 5	Jul-2022	Results / Stochastics, Action Items
Write IRP Draft	Sep-2022	
Draft Feedback Due	Oct-2022	
File	Dec-2022	

EXHIBIT 1: AVISTA'S 2021 NATURAL GAS IRP MODELING PROCESS

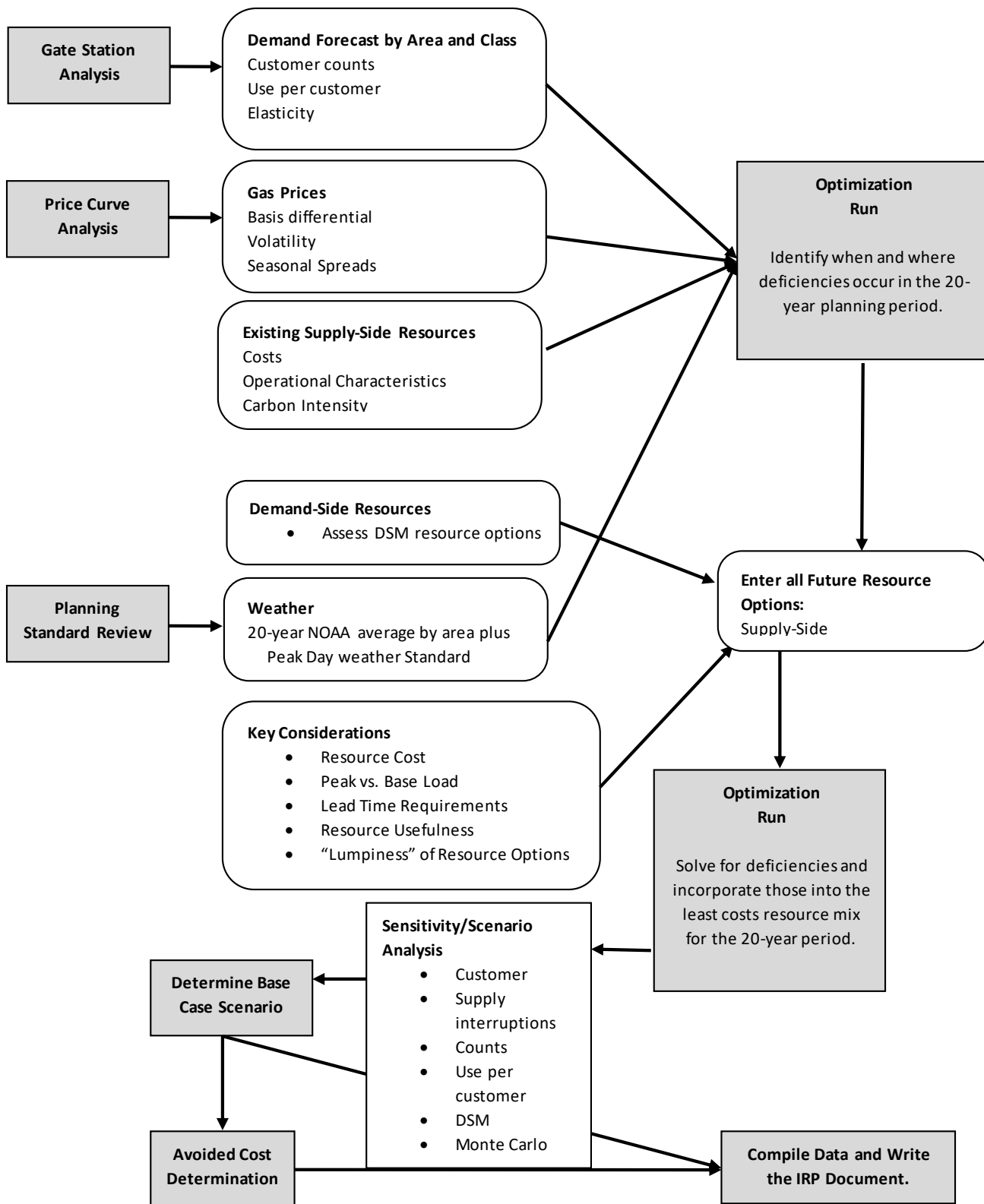

APPENDIX 1.2: WASHINGTON PUBLIC UTILITY COMMISSION IRP POLICIES AND GUIDELINES – WAC 480-90-238

Rule	Requirement	Plan Citation
WAC 480-90-238(4)	Work plan filed no later than 12 months before next IRP due date.	Work plan submitted to the WUTC on August 31, 2019, See attachment to this Appendix 1.1.
WAC 480-90-238(4)	Work plan outlines content of IRP.	See work plan attached to this Appendix 0.1.
WAC 480-90-238(4)	Work plan outlines method for assessing potential resources. (See LRC analysis below)	See Appendix 1.1.
WAC 480-90-238(5)	Work plan outlines timing and extent of public participation.	See Appendix 1.1.
WAC 480-90-238(4)	Integrated resource plan submitted within two years of previous plan.	Last Integrated Resource Plan was submitted on August 31, 2018
WAC 480-90-238(5)	Commission issues notice of public hearing after company files plan for review.	TBD
WAC 480-90-238(5)	Commission holds public hearing.	TBD
WAC 480-90-238(2)(a)	Plan describes mix of natural gas supply resources.	See Chapter 4 on Supply Side Resources
WAC 480-90-238(2)(a)	Plan describes conservation supply.	See Chapter 3 on Demand Side Resources
WAC 480-90-238(2)(a)	Plan addresses supply in terms of current and future needs of utility and ratepayers.	See Chapter 4 on Supply Side Resources and Chapter 6 Integrated Resource Portfolio
WAC 480-90-238(2)(a)&(b)	Plan uses lowest reasonable cost (LRC) analysis to select mix of resources.	See Chapters 3 and 4 for Demand and Supply Side Resources. Chapters 6 and 7 details how Demand and Supply come together to select the least cost/best risk portfolio for ratepayers.
WAC 480-90-238(2)(b)	LRC analysis considers resource costs.	See Chapters 3 and 4 for Demand and Supply Side Resources. Chapters 6 and 7 details how Demand and Supply come together to select the least cost/best risk portfolio for ratepayers.
WAC 480-90-238(2)(b)	LRC analysis considers market-volatility risks.	See Chapter 4 on Supply Side Resources
WAC 480-90-238(2)(b)	LRC analysis considers demand side uncertainties.	See Chapter 2 Demand Forecasting
WAC 480-90-238(2)(b)	LRC analysis considers resource effect on system operation.	See Chapter 4 and Chapter 6
WAC 480-90-238(2)(b)	LRC analysis considers risks imposed on ratepayers.	See Chapter 4 procurement plan section. We seek to minimize but cannot eliminate price risk for our customers.
WAC 480-90-238(2)(b)	LRC analysis considers public policies regarding resource preference	See Chapter 2 demand scenarios

	adopted by Washington state or federal government.	
WAC 480-90-238(2)(b)	LRC analysis considers cost of risks associated with environmental effects including emissions of carbon dioxide.	See Chapters 2 and 6 on demand scenarios and Integrated Resource Portfolio
WAC 480-90-238(2)(b)	LRC analysis considers need for security of supply.	See Chapter 4 on Supply Side Resources
Rule	Requirement	Plan Citation
WAC 480-90-238(2)(c)	Plan defines conservation as any reduction in natural gas consumption that results from increases in the efficiency of energy use or distribution.	See Chapter 3 on Demand Side Resources
WAC 480-90-238(3)(a)	Plan includes a range of forecasts of future demand.	See Chapter 2 on Demand Forecast
WAC 480-90-238(3)(a)	Plan develops forecasts using methods that examine the effect of economic forces on the consumption of natural gas.	See Chapter 2 on Demand Forecast
WAC 480-90-238(3)(a)	Plan develops forecasts using methods that address changes in the number, type and efficiency of natural gas end-uses.	See Chapter 2 on Demand Forecast
WAC 480-90-238(3)(b)	Plan includes an assessment of commercially available conservation, including load management.	See Chapter 3 on Demand Side Management including demand response section.
WAC 480-90-238(3)(b)	Plan includes an assessment of currently employed and new policies and programs needed to obtain the conservation improvements.	See Chapter 3 and Appendix 3.1.
WAC 480-90-238(3)(c)	Plan includes an assessment of conventional and commercially available nonconventional gas supplies.	See Chapter 4 on Supply Side Resources
WAC 480-90-238(3)(d)	Plan includes an assessment of opportunities for using company-owned or contracted storage.	See Chapter 4 on Supply Side Resources
WAC 480-90-238(3)(e)	Plan includes an assessment of pipeline transmission capability and reliability and opportunities for additional pipeline transmission resources.	See Chapter 4 on Supply Side Resources
WAC 480-90-238(3)(f)	Plan includes a comparative evaluation of the cost of natural gas purchasing strategies, storage options, delivery resources, and improvements in conservation using a consistent method to calculate cost-effectiveness.	See Chapter 3 on Demand Side Resources and Chapter 4 on Supply Side Resources
WAC 480-90-238(3)(g)	Plan includes at least a 10 year long-range planning horizon.	Our plan is a comprehensive 20 year plan.
WAC 480-90-238(3)(g)	Demand forecasts and resource evaluations are integrated into the long range plan for resource acquisition.	Chapter 6 Integrated Resource Portfolio details how demand and supply come together to form the least cost/best risk portfolio.
WAC 480-90-238(3)(h)	Plan includes a two-year action plan that implements the long range plan.	See Section 9 Action Plan

WAC 480-90-238(3)(i)	Plan includes a progress report on the implementation of the previously filed plan.	See Section 9 Action Plan
WAC 480-90-238(5)	Plan includes description of consultation with commission staff. (Description not required)	See Section 1 Introduction
WAC 480-90-238(5)	Plan includes description of completion of work plan. (Description not required)	See Appendix 1.1.

APPENDIX 1.2: IDAHO PUBLIC UTILITY COMMISSION IRP POLICIES AND GUIDELINES – ORDER NO. 2534

	DESCRIPTION OF REQUIREMENT	FULLFILLMENT OF REQUIREMENT
1	Purpose and Process. Each gas utility regulated by the Idaho Public Utilities Commission with retail sales of more than 10,000,000,000 cubic feet in a calendar year (except gas utilities doing business in Idaho that are regulated by contract with a regulatory commission of another State) has the responsibility to meet system demand at least cost to the utility and its ratepayers. Therefore, an “integrated resource plan” shall be developed by each gas utility subject to this rule.	Avista prepares a comprehensive 20 year Integrated Resource Plan every two years. Avista will be filing its 2023 IRP on or before April 1, 2023.
2	Definition. Integrated resource planning. “Integrated resource planning” means planning by the use of any standard, regulation, practice, or policy to undertake a systematic comparison between demand-side management measures and the supply of gas by a gas utility to minimize life-cycle costs of adequate and reliable utility services to gas customers. Integrated resource planning shall take into account necessary features for system operation such as diversity, reliability, dispatchability, and other factors of risk and shall treat demand and supply to gas consumers on a consistent and integrated basis.	Avista's IRP brings together dynamic demand forecasts and matches them against demand-side and supply-side resources in order to evaluate the least cost/best risk portfolio for its core customers. While the primary focus has been to ensure customer's needs are met under peak or design weather conditions, this process also evaluates the resource portfolio under normal/average operating conditions. The IRP provides the framework and methodology for evaluating Avista's natural gas demand and resources.
3	Elements of Plan. Each gas utility shall submit to the Commission on a biennial basis an integrated resource plan that shall include:	Filing extension approved for 2021 IRP to be filed on or before April 1, 2021. The last IRP was filed on August 31, 2018.
	A range of forecasts of future gas demand in firm and interruptible markets for each customer class for one, five, and twenty years using methods that examine the effect of economic forces on the consumption of gas and that address changes in the number, type and efficiency of gas end-uses.	See Chapter 2 - Demand Forecasts and Appendix 2 et.al. for a detailed discussion of how demand was forecasted for this IRP.
	An assessment for each customer class of the technically feasible improvements in the efficient use of gas, including load management, as well as the policies and programs needed to obtain the efficiency improvements.	See Chapter 3 - Demand Side Management and DSM Appendices 3 et.al. for detailed information on the DSM potential evaluated and selected for this IRP and the operational implementation process.

	An analysis for each customer class of gas supply options, including: (1) a projection of spot market versus long-term purchases for both firm and interruptible markets; (2) an evaluation of the opportunities for using company-owned or contracted storage or production; (3) an analysis of prospects for company participation in a gas futures market; and (4) an assessment of opportunities for access to multiple pipeline suppliers or direct purchases from producers.	See Chapter 4 - Supply-Side Resources for details about the market, storage, and pipeline transportation as well as other resource options considered in this IRP. See also the procurement plan section in this same chapter for supply procurement strategies.
	A comparative evaluation of gas purchasing options and improvements in the efficient use of gas based on a consistent method for calculating cost-effectiveness.	See Methodology section of Chapter 3 - Demand-Side Resources where we describe our process on how demand-side and supply-side resources are compared on par with each other in the SENDOUT® model. Chapter 3 also includes how results from the IRP are then utilized to create operational business plans. Operational implementation may differ from IRP results due to modeling assumptions.
	The integration of the demand forecast and resource evaluations into a long-range (e.g., twenty-year) integrated resource plan describing the strategies designed to meet current and future needs at the lowest cost to the utility and its ratepayers.	See Chapter 6 - Integrated Resource Portfolio for details on how we model demand and supply coming together to provide the least cost/best risk portfolio of resources.
	A short-term (e.g., two-year) plan outlining the specific actions to be taken by the utility in implementing the integrated resource plan.	See Chapter 9 - Action Plan for actions to be taken in implementing the IRP.
4	Relationship Between Plans. All plans following the initial integrated resource plan shall include a progress report that relates the new plan to the previously filed plan.	Avista strives to meet at least bi-annually with Staff and/or Commissioners to discuss the state of the market, procurement planning practices, and any other issues that may impact resource needs or other analysis within the IRP.
5	Plans to Be Considered in Rate Cases. The integrated resource plan will be considered with other available information to evaluate the performance of the utility in rate proceedings before the Commission.	We prepare and file our plan in part to establish a public record of our plan.
6	Public Participation. In formulating its plan, the gas utility must provide an opportunity for public participation and comment and must provide methods that will be available to the public of validating predicted performance.	Avista held four Technical Advisory Committee meetings beginning in June and ending in November. See Chapter 1 - Introduction for more detail about public participation in the IRP process.

7	<p>Legal Effect of Plan. The plan constitutes the base line against which the utility's performance will ordinarily be measured. The requirement for implementation of a plan does not mean that the plan must be followed without deviation. The requirement of implementation of a plan means that a gas utility, having made an integrated resource plan to provide adequate and reliable service to its gas customers at the lowest system cost, may and should deviate from that plan when presented with responsible, reliable opportunities to further lower its planned system cost not anticipated or identified in existing or earlier plans and not undermining the utility's reliability.</p>	<p>See section titled "Avista's Procurement Plan" in Chapter 4 - Supply-Side Resources. Among other details we discuss plan revisions in response to changing market conditions.</p>
8	<p>In order to encourage prudent planning and prudent deviation from past planning when presented with opportunities for improving upon a plan, a gas utility's plan must be on file with the Commission and available for public inspection. But the filing of a plan does not constitute approval or disapproval of the plan having the force and effect of law, and deviation from the plan would not constitute violation of the Commission's Orders or rules. The prudence of a utility's plan and the utility's prudence in following or not following a plan are matters that may be considered in a general rate proceeding or other proceedings in which those issues have been noticed.</p>	<p>See also section titled "Alternate Supply-Side Scenarios" in Chapter 6 - Integrated Resource Portfolio where we discuss different supply portfolios that are responsive to changing assumptions about resource alternatives.</p>

APPENDIX 1.2: OREGON PUBLIC UTILITY COMMISSION IRP STANDARD AND GUIDELINES – ORDER 07-002

Guideline 1: Substantive Requirements		
1.a.1	All resources must be evaluated on a consistent and comparable basis.	All resource options considered, including demand-side and supply-side are modeled in SENDOUT® utilizing the same common general assumptions, approach and methodology.
1.a.2	All known resources for meeting the utility's load should be considered, including supply-side options which focus on the generation, purchase and transmission of power – or gas purchases, transportation, and storage – and demand-side options which focus on conservation and demand response.	Avista considered a range of resources including demand-side management, distribution system enhancements, capacity release recalls, interstate pipeline transportation, interruptible customer supply, and storage options including liquefied natural gas. Chapter 3 and Appendix 3.1 documents Avista's demand-side management resources considered. Chapter 4 and Appendix 6.3 documents supply-side resources. Chapter 6 and 7 documents how Avista developed and assessed each of these resources.
1.a.3	Utilities should compare different resource fuel types, technologies, lead times, in-service dates, durations and locations in portfolio risk modeling.	Avista considered various combinations of technologies, lead times, in-service dates, durations, and locations. Chapter 6 provides details about the modeling methodology and results. Chapter 4 describes resource attributes and Appendix 6.3 summarizes the resources' lead times, in-service dates and locations.
1.a.4	Consistent assumptions and methods should be used for evaluation of all resources.	Appendix 6.2 documents general assumptions used in Avista's SENDOUT® modeling software. All portfolio resources both demand and supply-side were evaluated within SENDOUT® using the same sets of inputs.
1.a.5	The after-tax marginal weighted-average cost of capital (WACC) should be used to discount all future resource costs.	Avista applied its after-tax WACC of 4.36% to discount all future resource costs. (See general assumptions at Appendix 6.2)
1.b.1	Risk and uncertainty must be considered. Electric utilities only	Not Applicable
1.b.2	Risk and uncertainty must be considered. Natural gas utilities should consider demand (peak, swing and base-load), commodity supply and price, transportation availability and price, and costs to comply with any regulation of greenhouse gas (GHG) emissions.	<p>Risk and uncertainty are key considerations in long term planning. In order to address risk and uncertainties a wide range of sensitivity, scenario and portfolio analysis is completed. A description of risk associated with each scenario is included in Appendix 2.6.</p> <p>Avista performed 33 sensitivities on demand and price. From there five demand scenarios were developed (Table 1.1) for SENDOUT® modeling purposes. Monthly demand coefficients were developed for base, heating demand while peak demand was contemplated through modeling a weather planning standard using 99% probability (see heating degree day data in Appendix 2.4).</p>

		<p>Avista evaluated several price forecasts and performed stochastic simulations to derive a high and a low price based on the Expected price.</p> <p>Avista stochastic modeling techniques for price and weather variables to analyze weather sensitivity and to quantify the risk to customers under varying price environments. While there continues to be some uncertainty around GHG emission, Avista considered GHG emissions regulatory compliance costs in Appendix 3.2. As currently modeled, we include a carbon adder if the commodity is selected in the base</p>
	Utilities should identify in their plans any additional sources of risk and uncertainty.	<p>Avista evaluated additional risks and uncertainties. Risks associated with the planning environment are detailed in Chapter 0 Introduction. Avista also analyzed demand risk which is detailed in Chapter 2. Chapter 3 discusses the uncertainty around how much DSM is achievable. Supply-side resource risks are discussed in Chapter 4. Chapter 6 and 7 discusses the variables modeled for scenario and stochastic risk analysis.</p>
1c	The primary goal must be the selection of a portfolio of resources with the best combination of expected costs and associated risks and uncertainties for the utility and its customers.	<p>Avista evaluated cost/risk tradeoffs for each of the risk analysis portfolios considered. See Chapter 5 and 6 plus supporting information in Appendix 2.6 for Avista's portfolio risk analysis and determination of the preferred portfolio.</p>
	The planning horizon for analyzing resource choices should be at least 20 years and account for end effects. Utilities should consider all costs with a reasonable likelihood of being included in rates over the long term, which extends beyond the planning horizon and the life of the resource.	<p>Avista used a 20-year study period for portfolio modeling. Avista contemplated possible costs beyond the planning period that could affect rates including end effects such as infrastructure decommission costs and concluded there were no significant costs reasonably likely to impact rates under different resource selection scenarios.</p>
	Utilities should use present value of revenue requirement (PVRR) as the key cost metric. The plan should include analysis of current and estimated future costs of all long-lived resources such as power plants, gas storage facilities and pipelines, as well as all short-lived resources such as gas supply and short-term power purchases.	<p>Avista's SENDOUT® modeling software utilizes a PVRR cost metric methodology applied to both long and short-lived resources.</p>
	To address risk, the plan should include at a minimum: 1) Two measures of PVRR risk: one that measures the variability of costs and one that measures the severity of bad outcomes. 2) Discussion of the proposed use and impact on costs and risks of physical and financial hedging.	<p>Avista, through its stochastic analysis, modeled 1,000 scenarios around varying gas price inputs via Monte Carlo iterations developing a distribution of Total 20 year cost estimates utilizing SENDOUT®'s PVRR methodology. Chapter 7 further describes this analysis. The variability of costs is plotted against the Expected Case while the scenarios beyond the 95th percentile capture the severity of outcomes. Chapter 4</p>

		discusses Avista's physical and financial hedging methodology.
	The utility should explain in its plan how its resource choices appropriately balance cost and risk.	Chapter 4, 5, 6, and 7 describe various specific resource considerations and related risks, and describes what criteria we used to determine what resource combinations provide an appropriate balance between cost and risk.
1d	The plan must be consistent with the long-run public interest as expressed in Oregon and federal energy policies.	Avista considered current and expected state and federal energy policies in portfolio modeling. Chapter 6 describes the decision process used to derive portfolios, which includes consideration of state resource policy directions.
Guideline 2: Procedural Requirements		
2a	The public, including other utilities, should be allowed significant involvement in the preparation of the IRP. Involvement includes opportunities to contribute information and ideas, as well as to receive information. Parties must have an opportunity to make relevant inquiries of the utility formulating the plan.	Chapter 1 provides an overview of the public process and documents the details on public meetings held for the 2018 IRP. Avista encourages participation in the development of the plan, as each party brings a unique perspective and the ability to exchange information and ideas makes for a more robust plan.
	While confidential information must be protected, the utility should make public, in its plan, any non-confidential information that is relevant to its resource evaluation and action plan.	The entire IRP, as well as the TAC process, includes all of the non-confidential information the company used for portfolio evaluation and selection. Avista also provided stakeholders with non-confidential information to support public meeting discussions via email. The document and appendices will be available on the company website for viewing.
	The utility must provide a draft IRP for public review and comment prior to filing a final plan with the Commission.	Avista distributed a draft IRP document for external review to all TAC members on January 4, 2021 and requested comments by February 3, 2021
Guideline 3: Plan Filing, Review and Updates		
3a	Utility must file an IRP within two years of its previous IRP acknowledgement order.	Acknowledgement of the 2018 IRP was on March 11, 2020. The 2021 IRP will be filed on April 1, 2021 or within two years of previous acknowledgement order
3b	Utility must present the results of its filed plan to the Commission at a public meeting prior to the deadline for written public comment.	Avista will work with Staff to fulfill this guideline following filing of the IRP.
3c	Commission staff and parties should complete their comments and recommendations within six months of IRP filing	Pending
3d	The Commission will consider comments and recommendations on a utility's plan at a public meeting before issuing an order on acknowledgment. The Commission may provide the utility an opportunity to revise the plan before issuing an acknowledgment order	Pending

3e	The Commission may provide direction to a utility regarding any additional analyses or actions that the utility should undertake in its next IRP.	Pending
3f	Each utility must submit an annual update on its most recently acknowledged plan. The update is due on or before the acknowledgment order anniversary date. Once a utility anticipates a significant deviation from its acknowledged IRP, it must file an update with the Commission, unless the utility is within six months of filing its next IRP. The utility must summarize the update at a Commission public meeting. The utility may request acknowledgment of changes in proposed actions identified in an update	The annual update was submitted on January 26, 2020. The filing was a filing requesting an extension from August 31, 2020 to April 1, 2021. Approval was given through Order 20-071 on March 11, 2020.
3g	Unless the utility requests acknowledgement of changes in proposed actions, the annual update is an informational filing that: <ul style="list-style-type: none"> Describes what actions the utility has taken to implement the plan; Provides an assessment of what has changed since the acknowledgment order that affects the action plan, including changes in such factors as load, expiration of resource contracts, supply-side and demand-side resource acquisitions, resource costs, and transmission availability; and Justifies any deviations from the acknowledged action plan. 	The updates described in 3f above explained changes since acknowledgment of the 2018 IRP and an update of emerging planning issues. The updates did not request acknowledgement of any changes.
Guideline 4: Plan Components		
	At a minimum, the plan must include the following elements:	
4a	An explanation of how the utility met each of the substantive and procedural requirements.	This table summarizes guideline compliance by providing an overview of how Avista met each of the substantive and procedural requirements for a natural gas IRP.
4b	Analysis of high and low load growth scenarios in addition to stochastic load risk analysis with an explanation of major assumptions.	Avista developed six demand growth forecasts for scenario analysis. Stochastic variability of demand was also captured in the risk analysis. Chapter 2 describes the demand forecast data and Chapter 7 provides the scenario and risk analysis results. Appendix 5 details major assumptions.
4c	For electric utilities only	Not Applicable

4d	A determination of the peaking, swing and base-load gas supply and associated transportation and storage expected for each year of the plan, given existing resources; and identification of gas supplies (peak, swing and base-load), transportation and storage needed to bridge the gap between expected loads and resources.	Figures 6.10 – 6.17 summarize graphically projected annual peak day demand and the existing and selected resources by year to meet demand for the expected case. Appendix 6.1 and 6.2 summarizes the peak day demand for the other demand scenarios.
4e	Identification and estimated costs of all supply-side and demand-side resource options, taking into account anticipated advances in technology	Chapter 3 and Appendix 3.1 identify the demand-side potential included in this IRP. Chapter 4, 5 & 6 and Appendix 6.3 identify the supply-side resources.
4f	Analysis of measures the utility intends to take to provide reliable service, including cost-risk tradeoffs.	Chapter 6 and 7 discuss the modeling tools, customer growth forecasting and cost-risk considerations used to maintain and plan a reliable gas delivery system. These Chapters also capture a summary of the reliability analysis process demonstrated in the four TAC meetings. Chapter 4 discusses the diversified infrastructure and multiple supply basin approach that acts to mitigate certain reliability risks. Appendix 2.6 highlights key risks associated with each portfolio.
4g	Identification of key assumptions about the future (e.g. fuel prices and environmental compliance costs) and alternative scenarios considered.	Appendix 7 and Chapter 7 describe the key assumptions and alternative scenarios used in this IRP.
4h	Construction of a representative set of resource portfolios to test various operating characteristics, resource types, fuels and sources, technologies, lead times, in-service dates, durations and general locations - system-wide or delivered to a specific portion of the system.	This Plan documents the development and results for portfolios evaluated in this IRP (see Table 7.1 for scenarios considered).
4i	Evaluation of the performance of the candidate portfolios over the range of identified risks and uncertainties.	We evaluated our candidate portfolio by performing stochastic analysis using SENDOUT® varying price under 1,000 different scenarios. Additionally, we test the portfolio of options with the use of SENDOUT® under deterministic scenarios where demand and price vary. For resources selected, we assess other risk factors such as varying lead times required and potential for cost overruns outside of the amounts included in the modeling assumptions.
4j	Results of testing and rank ordering of the portfolios by cost and risk metric, and interpretation of those results.	Avista's four distinct geographic Oregon service territories limit many resource option synergies which inherently reduces available portfolio options. Feasibility uncertainty, lead time variability and uncertain cost escalation around certain resource options also reduce reasonably viable options. Chapter 4 describes resource options reviewed including discussion on uncertainties in lead times and costs as well as viability and resource availability (e.g.

		LNG). Appendix 6.3 summarizes the potential resource options identifying investment and variable costs, asset availability and lead time requirements while results of resources selected are identified in Table 6.5 as well as graphically presented in Figure 6.18 and 6.19 for the Expected Case and Appendix 7.1 for the High Growth case.
4k	Analysis of the uncertainties associated with each portfolio evaluated	See the responses to 1.b above.
4l	Selection of a portfolio that represents the best combination of cost and risk for the utility and its customers	Avista evaluated cost/risk tradeoffs for each of the risk analysis portfolios considered. Chapter 6 and Appendix 2.6 show the company's portfolio risk analysis, as well as the process and determination of the preferred portfolio.
4m	Identification and explanation of any inconsistencies of the selected portfolio with any state and federal energy policies that may affect a utility's plan and any barriers to implementation	This IRP is presumed to have no inconsistencies.
4n	An action plan with resource activities the utility intends to undertake over the next two to four years to acquire the identified resources, regardless of whether the activity was acknowledged in a previous IRP, with the key attributes of each resource specified as in portfolio testing.	Chapter 9 presents the IRP Action Plan with focus on the following areas: <ul style="list-style-type: none"> Modeling Policy Supply/capacity/distribution Forecasting Regulatory communication DSM
Guideline 5: Transmission		
5	Portfolio analysis should include costs to the utility for the fuel transportation and electric transmission required for each resource being considered. In addition, utilities should consider fuel transportation and electric transmission facilities as resource options, taking into account their value for making additional purchases and sales, accessing less costly resources in remote locations, acquiring alternative fuel supplies, and improving reliability.	Not applicable to Avista's gas utility operations.
Guideline 6: Conservation		
6a	Each utility should ensure that a conservation potential study is conducted periodically for its entire service territory.	AEG performed a conservation potential assessment study for our 2021 IRP. A discussion of the study is included in Chapter 3. The full study document is in Appendix 3.1. Avista incorporates a comprehensive assessment of the potential for utility acquisition of energy-efficiency resources into the regularly-scheduled Integrated Resource Planning process.

6b	To the extent that a utility controls the level of funding for conservation programs in its service territory, the utility should include in its action plan all best cost/risk portfolio conservation resources for meeting projected resource needs, specifying annual savings targets.	A discussion on the treatment of conservation programs is included in Chapter 3 while selection methodology is documented in Chapter 6. The action plan details conservation targets, if any, as developed through the operational business planning process. These targets are updated annually, with the most current avoided costs. Given the challenge of the low cost environment, current operational planning and program evaluation is still underway and targets for Oregon have not yet been set.
6c	To the extent that an outside party administers conservation programs in a utility's service territory at a level of funding that is beyond the utility's control, the utility should: 1) determine the amount of conservation resources in the best cost/ risk portfolio without regard to any limits on funding of conservation programs; and 2) identify the preferred portfolio and action plan consistent with the outside party's projection of conservation acquisition.	Not applicable. See the response for 6.b above.
Guideline 7: Demand Response		
7	Plans should evaluate demand response resources, including voluntary rate programs, on par with other options for meeting energy, capacity, and transmission needs (for electric utilities) or gas supply and transportation needs (for natural gas utilities).	Avista has periodically evaluated conceptual approaches to meeting capacity constraints using demand-response and similar voluntary programs. Technology, customer characteristics and cost issues are hurdles for developing effective programs.
Guideline 8: Environmental Costs		
8	Utilities should include, in their base-case analyses, the regulatory compliance costs they expect for CO ₂ , NO _x , SO ₂ , and Hg emissions. Utilities should analyze the range of potential CO ₂ regulatory costs in Order No. 93-695, from \$0 - \$40 (1990\$). In addition, utilities should perform sensitivity analysis on a range of reasonably possible cost adders for NO _x , SO ₂ , and Hg, if applicable.	As discussed in Chapter 5, all upstream emissions from the point of use are included in this IRP. The Environmental Externalities discussion in Appendix 3.2 describes our analysis performed. See also the guidelines addendum reflecting revised guidance for environmental costs per Order 08-339.
Guideline 9: Direct Access Loads		
9	An electric utility's load-resource balance should exclude customer loads that are effectively committed to service by an alternative electricity supplier.	Not applicable to Avista's gas utility operations.
Guideline 10: Multi-state utilities		
10	Multi-state utilities should plan their generation and transmission systems, or gas supply and delivery, on an	The 2021 IRP conforms to the multi-state planning approach.

	integrated-system basis that achieves a best cost/risk portfolio for all their retail customers.	
Guideline 11: Reliability		
11	Electric utilities should analyze reliability within the risk modeling of the actual portfolios being considered. Loss of load probability, expected planning reserve margin, and expected and worst-case unserved energy should be determined by year for top-performing portfolios. Natural gas utilities should analyze, on an integrated basis, gas supply, transportation, and storage, along with demand-side resources, to reliably meet peak, swing, and base-load system requirements. Electric and natural gas utility plans should demonstrate that the utility's chosen portfolio achieves its stated reliability, cost and risk objectives.	Avista's storage and transport resources while planned around meeting a peak day planning standard, also provides opportunities to capture off season pricing while providing system flexibility to meet swing and base-load requirements. Diversity in our transport options enables at least dual fuel source options in event of a transport disruption. For areas with only one fuel source option the cost of duplicative infrastructure is not feasible relative to the risk of generally high reliability infrastructure.
Guideline 12: Distributed Generation		
12	Electric utilities should evaluate distributed generation technologies on par with other supply-side resources and should consider, and quantify where possible, the additional benefits of distributed generation.	Not applicable to Avista's gas utility operations.
Guideline 13: Resource Acquisition		
13a	An electric utility should: identify its proposed acquisition strategy for each resource in its action plan; Assess the advantages and disadvantages of owning a resource instead of purchasing power from another party; identify any Benchmark Resources it plans to consider in competitive bidding.	Not applicable to Avista's gas utility operations.
13b	Natural gas utilities should either describe in the IRP their bidding practices for gas supply and transportation, or provide a description of those practices following IRP acknowledgment.	A discussion of Avista's procurement practices is detailed in Chapter 4.
Guideline 8: Environmental Costs		
a.	BASE CASE AND OTHER COMPLIANCE SCENARIOS: The utility should construct a base-case scenario to reflect what it considers to be the most likely regulatory compliance future for carbon dioxide (CO ₂), nitrogen oxides, sulfur oxides, and mercury emissions. The utility also should develop several compliance scenarios ranging from the present CO ₂ regulatory level to the upper reaches of credible proposals by governing entities. Each compliance scenario should include a time profile of CO ₂ compliance requirements. The utility should identify whether the basis of those requirements, or "costs", would be CO ₂ taxes, a ban on certain types of resources, or CO ₂ caps (with or without flexibility	Upstream gas system infrastructure (pipelines, storage facilities, and gathering systems) do produce CO ₂ emissions via compressors used to pressurize and move gas throughout the system. The Environmental Externalities discussion in Appendix 3.2 describes our process for addressing these costs.

	mechanisms such as allowance or credit trading or a safety valve). The analysis should recognize significant and important upstream emissions that would likely have a significant impact on its resource decisions. Each compliance scenario should maintain logical consistency, to the extent practicable, between the CO ₂ regulatory requirements and other key inputs.	
b.	TESTING ALTERNATIVE PORTFOLIOS AGAINST THE COMPLIANCE SCENARIOS: The utility should estimate, under each of the compliance scenarios, the present value of revenue requirement (PVRR) costs and risk measures, over at least 20 years, for a set of reasonable alternative portfolios from which the preferred portfolio is selected. The utility should incorporate end-effect considerations in the analyses to allow for comparisons of portfolios containing resources with economic or physical lives that extend beyond the planning period. The utility should also modify projected lifetimes as necessary to be consistent with the compliance scenario under analysis. In addition, the utility should include, if material, sensitivity analyses on a range of reasonably possible regulatory futures for nitrogen oxides, sulfur oxides, and mercury to further inform the preferred portfolio selection.	The Environmental Externalities discussion in Appendix 3.2 describes our process for addressing these costs.

APPENDIX 2.1: ECONOMIC OUTLOOK AND CUSTOMER COUNT FORECAST

I. Service Area Economic Performance and Outlook

Avista's core service area for natural gas includes Eastern Washington, Northern Idaho, and Southwest Oregon. Smaller service islands are also located in rural South-Central Washington and Northeast Oregon. Our service area is dominated by four metropolitan statistical areas (MSAs): the Spokane-Spokane Valley, WA MSA (Spokane-Stevens counties); the Coeur d'Alene, ID MSA (Kootenai County); the Lewiston-Clarkson, ID-WA MSA (Nez Perce-Asotin counties); the Medford, OR MSA (Jackson County); and Grants Pass, OR MSA (Josephine County). These five MSAs represent the primary demand for Avista's natural gas and account for 75% of both customers (i.e., meters) and load. The remaining 25% of customers and load are spread over low density rural areas in all three states.

Figure 1: Employment and Population Recovery, December 2007- December 2020

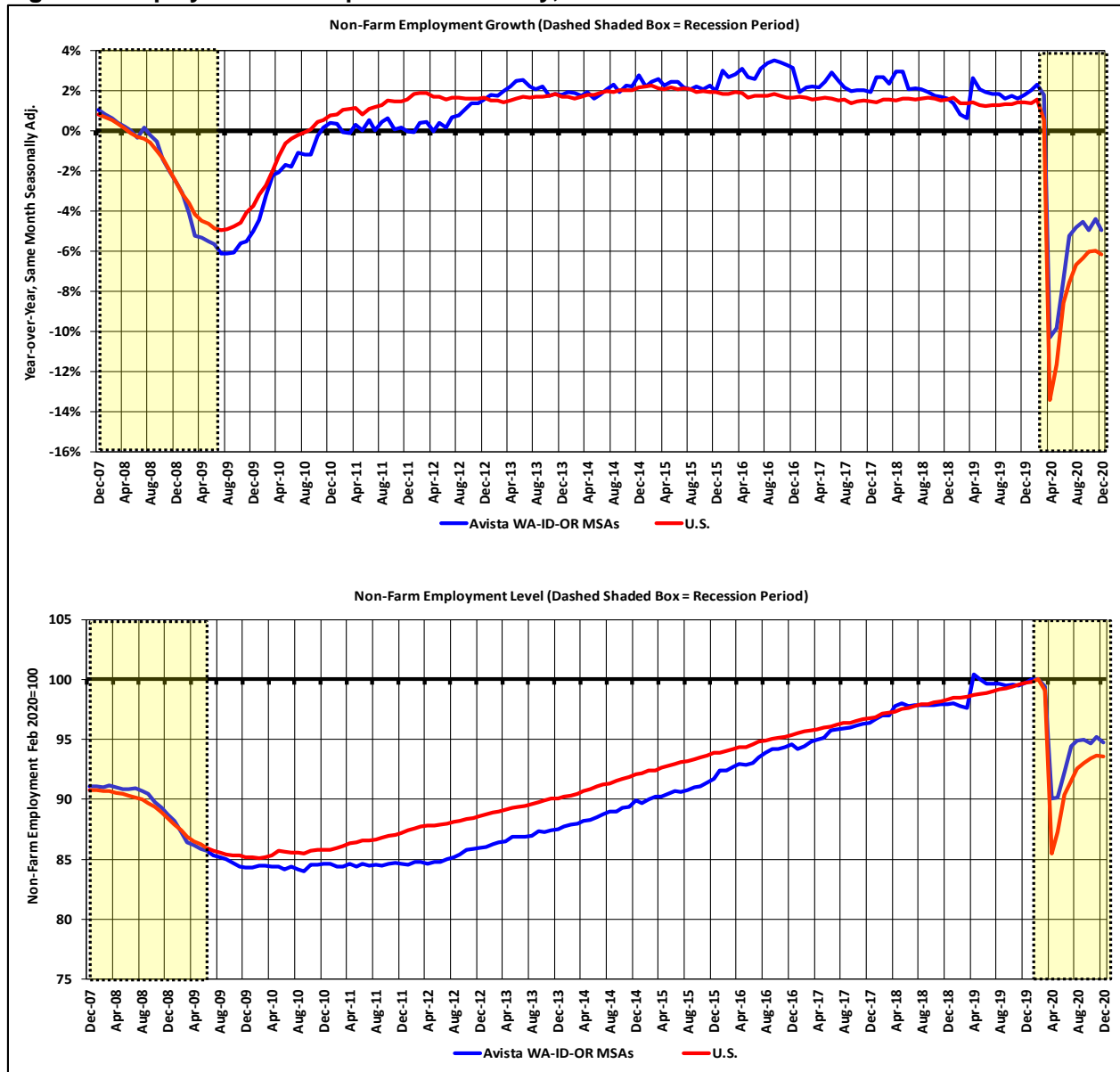

Data source: Employment from the BLS; population from the U.S. Census.

In the wake of the Great Recession, our service area recovered more slowly than the U.S. Although the U.S. recession officially ended in June 2009 (dated by the National Bureau of Economic Research), our service area did not start a significant employment recovery until the second half of 2012 (Figure 1, top and bottom graph). However, by the end of 2015, year-over-year employment growth exceeded U.S. growth and employment levels returned to pre-recession levels. Due to strong employment growth in the 2016-2019 period, the total percentage gain in employment was roughly the same as the U.S. by the middle of 2018. As a result, service area population growth, which is significantly influenced by immigration through employment opportunities, continued to improve after 2014 (Figure 2). This is important because population growth is the largest contributor to overall customer growth.

However, as Figure 1 shows Avista's service areas did not escape the employment impacts of COVID-19 induced recession at the start of 2020. The expectation in IRP customer forecast is that COVID-19 recession will slow population growth in 2021, with a return to pre-pandemic growth starting in 2022. Historically, service area population growth has slowed in one or more years following an employment shock.

Figure 2: Avista MSA Annual Population Growth, 2005-2019

Figure 3 shows that compared to the 2018 IRP, actual average customer growth in WA-ID over the 2018-2018 period is considerably higher than forecasted. This reflects (1) stronger than expected population growth, especially in ID, and (2) Avista's LEAP gas conversion program in WA (which expired in February 2019). In contrast, OR's actual growth rate is equal to forecast over the same period. Figure 4 shows since the 2018 IRP, customer growth has significantly exceeded population growth, which reflects customer growth from existing homes converting to gas in addition to new construction installing gas.

Compared to the 2018 IRP, this IRP shows a system-wide downward revision of approximately 1,400 customers by 2040. This reflects the net impact of a 1,400-customer increase in WA-ID and 2,800 decrease in OR. The OR change reflects lower forecasted population growth in the Roseburg and Klamath service regions. Figure 5 and Table 1 show the change in the customer forecast by for the system and by class between the 2016 and 2018 IRPs.

Figure 3: Comparison of 2018-IRP Customer Growth Forecasts to Actuals, 2018-2020

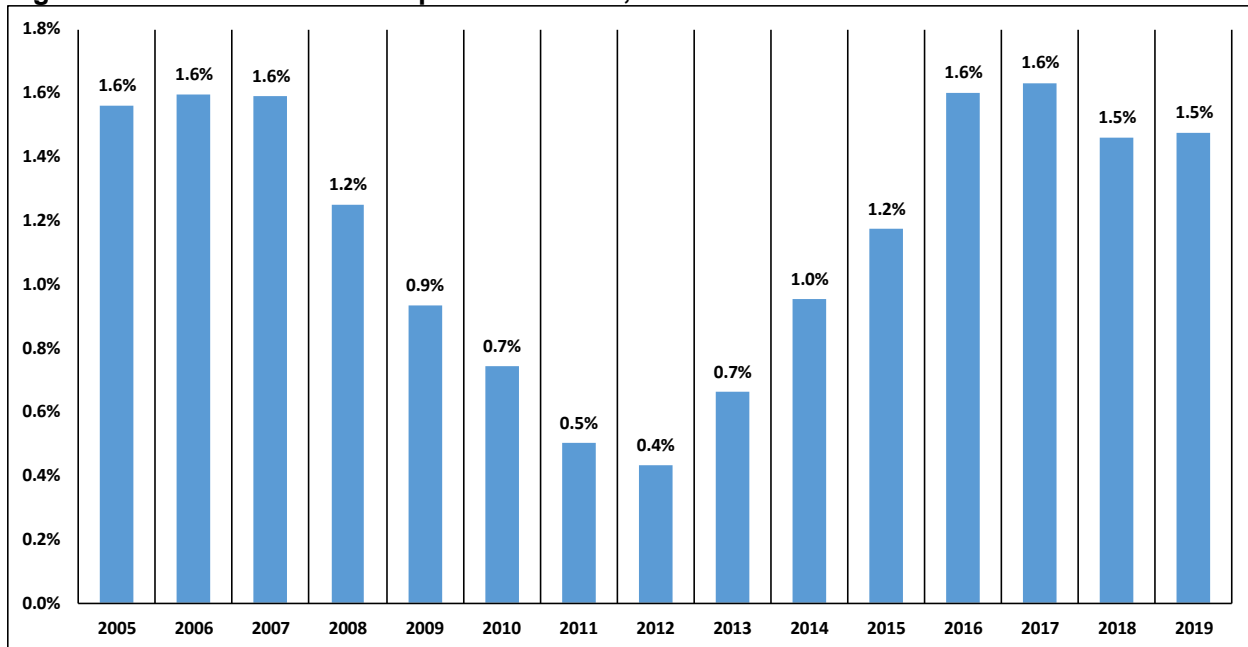
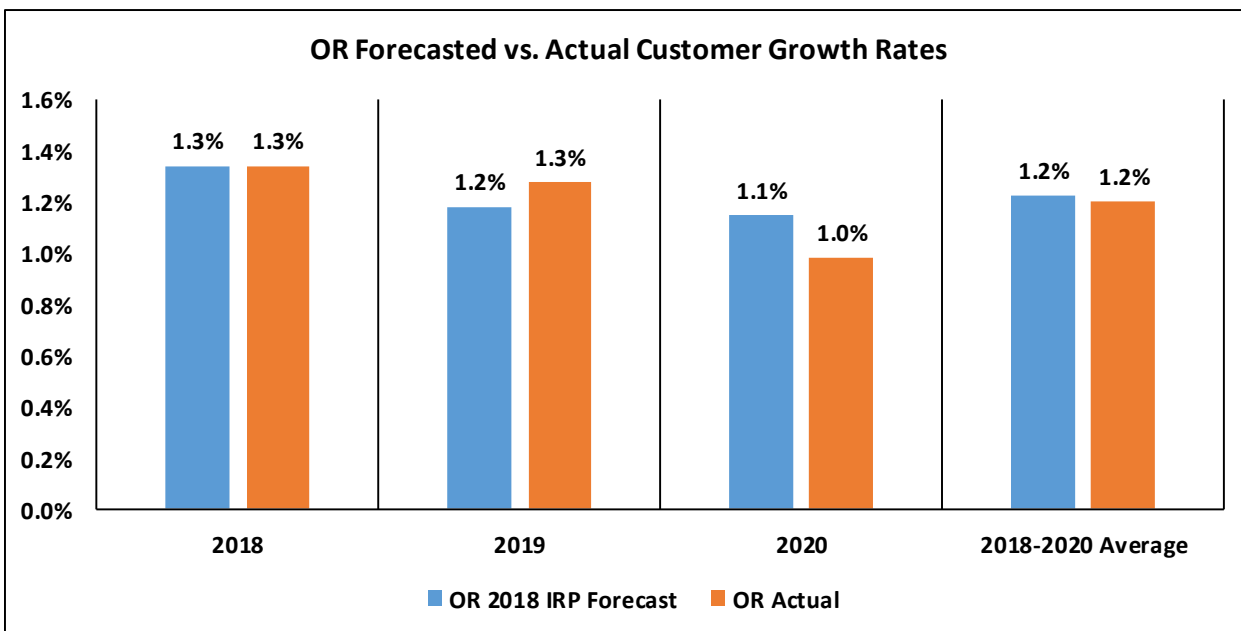
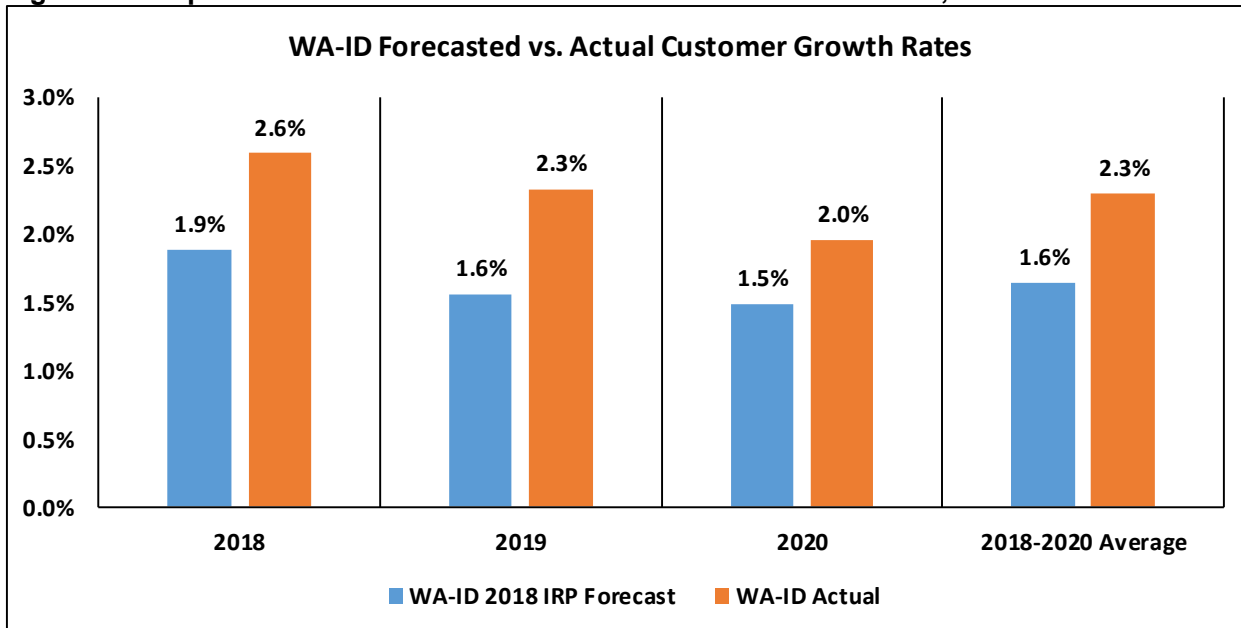

Data source: Company data.

Figure 4: Customer and Population Growth, 2005-2019

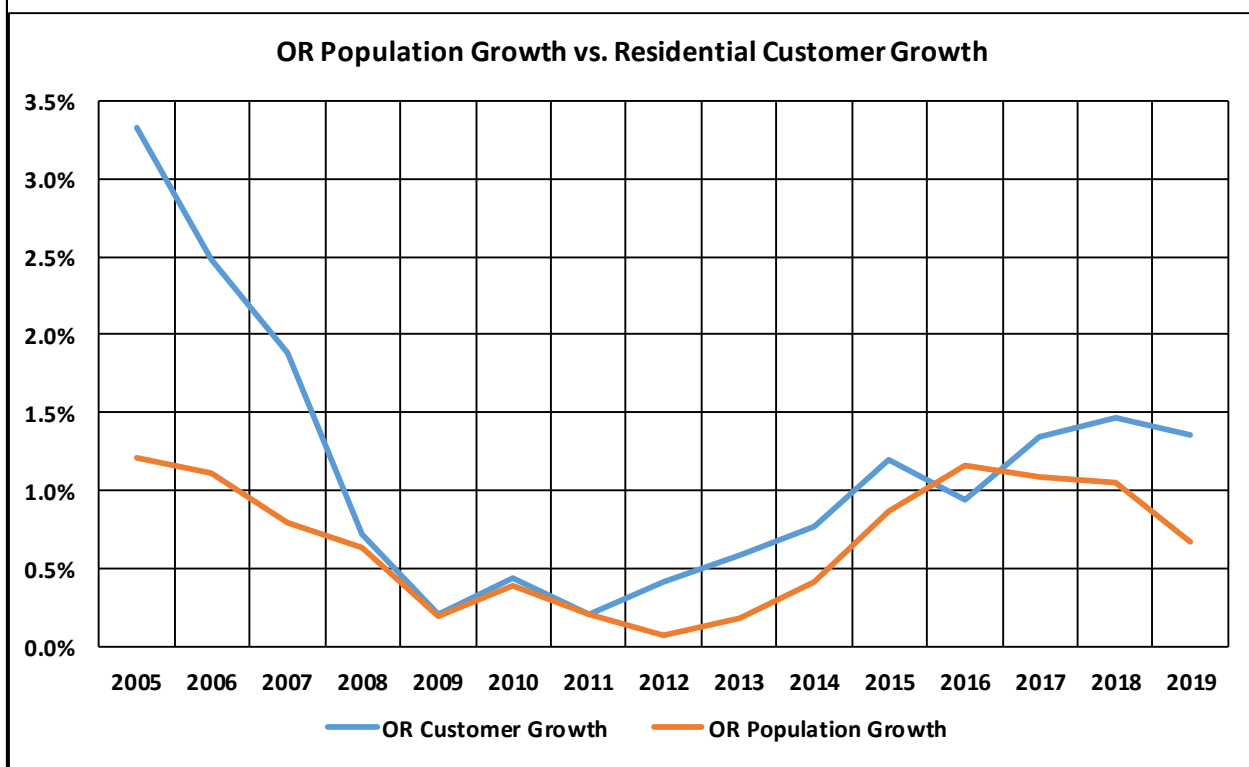
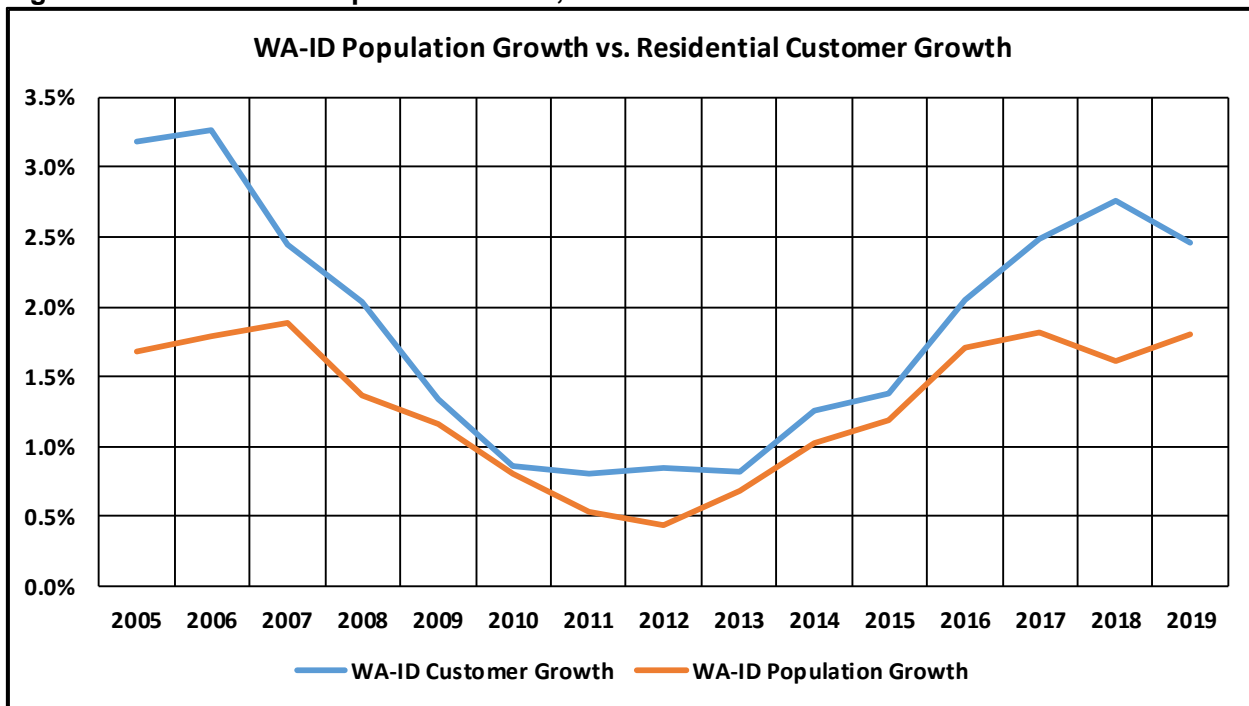

Data source: Company data.

Table 1: Change in Forecast between the 2018 IRP and 2021 IRP in 2040

Area	Residential	Commercial	Industrial	Total Change
WA-ID	+2,493	- 1,077	-22	+1,394
OR	-2,440	-351	-2	-2,793
System	53	-1,428	-24	-1,400

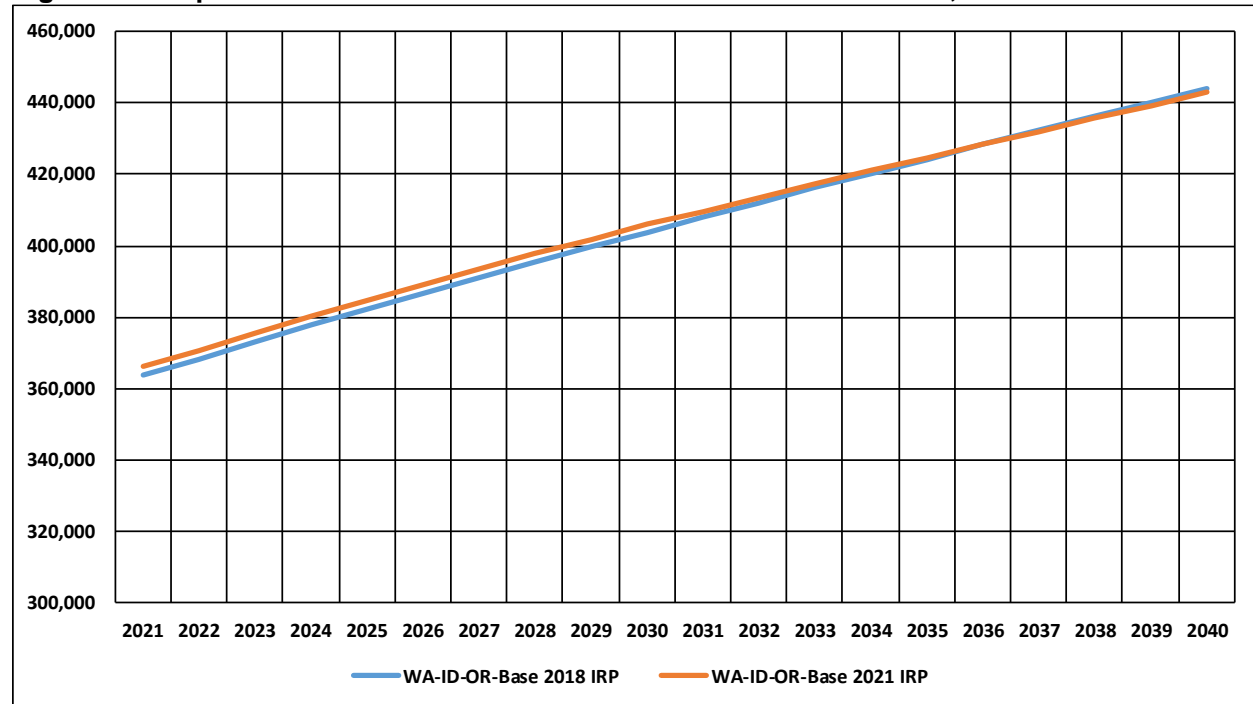
Figure 5: Comparison IRP Forecasted Customer Growth in WA-ID and OR, 2021-2040

Data source: Company data.

In past IRPs, the modeling approach for the majority of commercial customers *assumed* that residential customer growth (WA-ID schedule 101 and OR schedule 410 in Medford and Klamath Falls regions) is a driver of commercial customer growth (WA-ID schedule 101 and OR schedule 420 in Medford and Klamath Falls). The use of residential customers as a forecast driver for commercial customers reflects the historically high correlation between residential and commercial customer growth rates. However, because of the LEAP program, schedule 101 residential customers are no longer the primary driver in the commercial forecast in WA. The LEAP program altered the historical relationship between residential and commercial customers because the program was not offered to commercial customers. As a result, population has replaced residential customers as the primary driver of commercial customer forecast. This is also the case for ID, but for different reasons. In ID, the relationship between residential and commercial customers is changing such that using population directly produces better model diagnostics.

The forecast for system-wide industrial customers is lower compared to the 2018 IRP. Approximately 90% of industrial customers are in WA-ID. Figure 6 (top graph) shows total system-wide firm industrial customers since 2004. Following a sharp drop over the 2004-2006 period, firm industrial customers started to decline starting in 2016. It should be noted that some of the decline between 2019 and 2020 reflects a reclassification of some WA-ID customers to firm commercial schedules. This reclassification reflects customers that were incorrectly placed in firm industrial schedules in years past. Separating out WA-ID and OR (middle graph), the number of firm customers in WA-ID continuously fell over the 2004-2011 period; stabilized over the 2012-15; and then started to decline again. In contrast, OR customers increased over the 2004-2011 period (bottom graph). However, after a period of stability during the 2011-2014 period, customers declined modestly. Therefore, like the 2018 IRP, the current IRP forecast shows a declining base.

Figure 7: Industrial Customer Count, 2004-2020

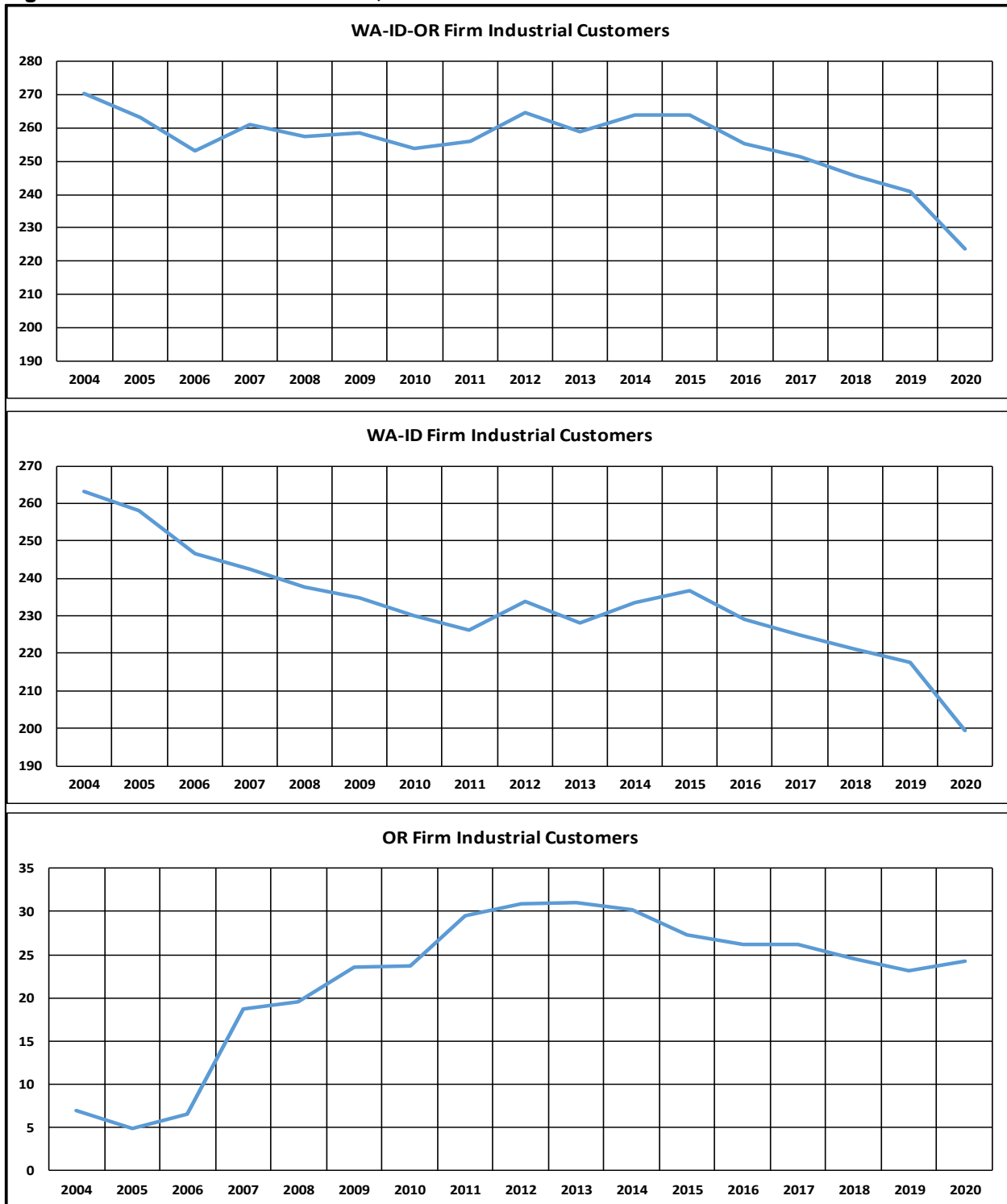

Data source: Company data.

II. IRP Forecast Process and Methodology

The customer forecasts are generated from forecasting models that are either regression models with ARIMA error corrections or simple smoothing models. The ARIMA error correction models are estimated

using SAS/ETS software. The customer forecasts are used as input into Sendout® to generate the IRP load forecasts.

Population growth is the key driver for the residential and commercial customer forecasts. Other variables include (1) seasonal dummy variables and (2) outlier dummy variables that control for extreme customer counts associated with double billing, software conversions, and customer movements from one billing schedule to another.

As noted above, the population growth forecast is the key driver behind the customer forecast for WA-ID residential schedules 101 and OR residential schedule 410. These two schedules represent the majority of customers and, therefore, drive overall residential customer growth. Because of their size and growth potential, a multi-step forecasting process has been developed for the Spokane-Spokane Valley, Coeur d'Alene, and Medford+Grants Pass MSAs. The process for forecasting population growth starts with a medium-term forecast horizon (2021-2025). This medium-term forecast is typically used for the annual financial forecast. However, during IRP years, this medium-term forecast is augmented with third party forecasts that cover the next twenty years. Starting with Figure 8, the five-year population forecast is a multi-step process that begins with a GDP forecast that drives the regional employment forecast, which in turn, drives a five-year population forecast.

Figure 8: Forecasting Population Growth, 2020-2025

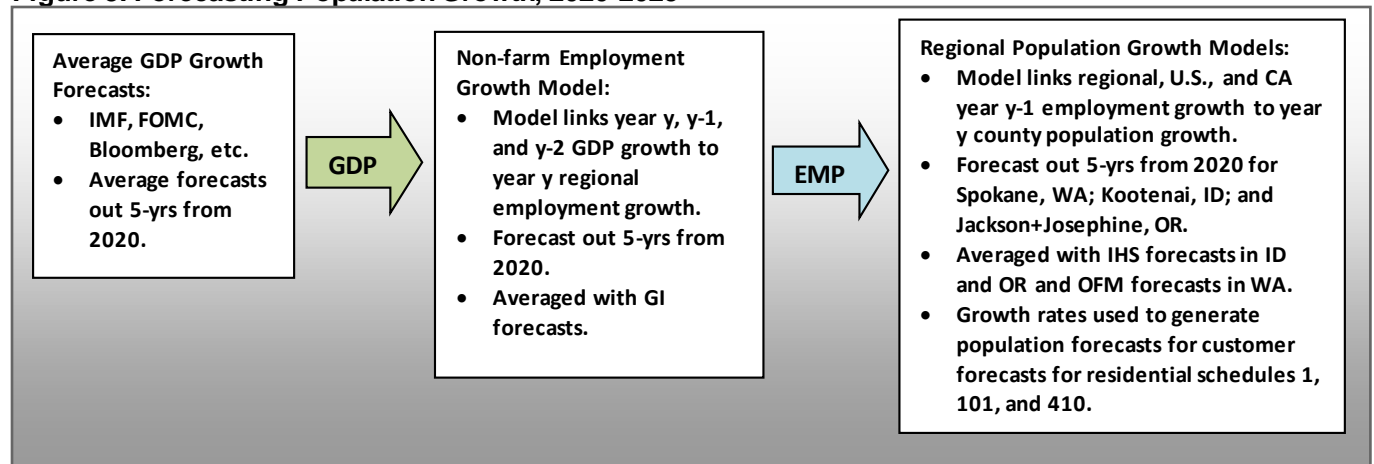

The forecasting models for regional employment growth are:

$$[1] GEMP_{y,SPK} = \vartheta_0 + \vartheta_1 GGDP_{y,US} + \vartheta_2 GGDP_{y-1,US} + \vartheta_3 GGDP_{y-2,US} + \omega_{SC} D_{KC,1998-2000=1} + \omega_{SC} D_{HB,2005-2007=1} + \epsilon_{t,y}$$

$$[2] GEMP_{y,KOOT} = \delta_0 + \delta_1 GGDP_{y,US} + \delta_2 GGDP_{y-1,US} + \delta_3 GGDP_{y-2,US} + \omega_{OL} D_{1994=1} + \omega_{OL} D_{2009=1} + \omega_{SC} D_{HB,2005-2007=1} + \epsilon_{t,y}$$

$$[3] GEMP_{y,JACK+JOS} = \phi_0 + \phi_1 GGDP_{y,US} + \phi_2 GGDP_{y-1,US} + \phi_3 GGDP_{y-2,US} + \omega_{SC} D_{HB,2004-2005=1} + ARIMA \epsilon_{t,y} (1,0,0)(0,0,0)_{12}$$

SPK is Spokane, WA (Spokane MSA), KOOT is Kootenai, ID (Coeur d'Alene MSA), and JACK+JOS is for the combination of Jackson County, OR (Medford MSA) and Josephine County, OR (Grants Pass MSA). $GEMP_y$ is employment growth in year y, $GGDP_{y,US}$ is U.S. real GDP growth in year y. D_{KC} is a dummy variable for the collapse of Kaiser Aluminum in Spokane, and D_{HB} , is a dummy for the housing bubble, specific to each region. The average GDP forecasts are used in the estimated model to generate five-year employment growth forecasts. The employment forecasts are then averaged with IHS's forecasts for the same counties so that:

$$[4] F_{Avg}(GEMP_{y,SPK}) = \frac{F(GEMP_{y,SPK}) + F(GIHSEMP_{y,SPK})}{2}$$

$$[5] F_{Avg}(GEMP_{y,KOOT}) = \frac{F(GEMP_{y,KOOT}) + F(GIHSEMP_{y,KOOT})}{2}$$

$$[6] F_{Avg}(GEMP_{y,JACK+JOS}) = \frac{F(GEMP_{y,JACK+JOS}) + F(GIHSEMP_{y,JACK+JOS})}{2}$$

Averaging reduces the systematic errors of a single-source forecast. The averages [8.4] through [8.6] are used to generate the population growth forecasts, which are described next.

The forecasting models for regional population growth are:

$$[7] GPOP_{y,SPK} = \kappa_0 + \kappa_1 GEMP_{y-1,SPK} + \kappa_2 GEMP_{y-2,US} + \omega_{OL} D_{2001=1} + \epsilon_{t,y}$$

$$[8] GPOP_{y,KOOT} = \alpha_0 + \alpha_1 GEMP_{y-1,KOOT} + \alpha_2 GEMP_{y-2,US} + \omega_{OL} D_{1994=1} + \omega_{OL} D_{2002=1} + \omega_{SC} D_{HB,2007=1} + \epsilon_{t,y}$$

$$[9] GPOP_{y,JACK+JOS} = \psi_0 + \psi_1 GEMP_{y-1,JACK+JOS} + \psi_2 GEMP_{y-2,CA} + \omega_{OL} D_{1991=1} + \omega_{SC} D_{HB,2004-2006=1} + \epsilon_{t,y}$$

$D_{2001=1}$ and $D_{1991=1}$ are a dummy variables for recession impacts. $GEMP_{y-1,US}$ is U.S. employment growth in year $y-1$ and $GEMP_{y-2}$, and CA is California Employment growth in year $y-1$. Because of its close proximity to CA, CA employment growth is better predictor of Jackson, OR employment growth than U.S. growth. The averages [8.4] through [8.6] are used in [7] through [9] to generate population growth forecasts. These forecasts are combined with IHS's forecasts for Kootenai, ID; Jackson, OR; Josephine, OR, and the Office for Financial Management (OFM) for Spokane, WA in the form of a simple average:

$$[10] F_{Avg}(GPOP_{y,SPK}) = \frac{F(GPOP_{y,SPK}) + F(GOFMPOP_{y,SPK})}{2}$$

$$[11] F_{Avg}(GPOP_{y,KOOT}) = \frac{F(GPOP_{y,KOOT}) + F(GIHSPOP_{y,KOOT})}{2}$$

$$[12] F_{Avg}(GPOP_{y,JACK+JOS}) = \frac{F(GPOP_{y,JACK+JOS}) + F(GIHSPOP_{y,JACK+JOS})}{2}$$

Here, $F_{Avg}(GPOP_y)$ is used to forecast population to forecast residential customers in WA-ID 101 and OR 410 schedules for the Spokane, Kootenai, and Jackson+Josephine areas. In the case of Spokane, OFM forecasts are used because the IHS's forecasts exhibit a level and time-path that is inconsistent with recent population behavior. The population growth forecasts for the Douglas (Roseburg), Klamath (Klamath Falls); and Union (La Grande) counties come directly from IHS. Since all forecasted growth rates are annualized, they are converted to monthly rates. By way of example, the following is regression model for residential 101 customers for the Spokane region:

$$C_{t,y,WA101r} = \alpha_0 + \tau POP_{t,y,SPK} + \omega_{SD} D_{t,y} + \omega_{OL} D_{Oct\ 2015=1} + \omega_{OL} D_{Feb\ 2016=1} + \omega_{OL} D_{Mar\ 2018=1} + \omega_{OL} D_{Nov\ 2018=1} + ARIMA\epsilon_{t,y}(12,1,0)(0,0,0)_{12}$$

Where:

$\tau POP_{t,y,SPK}$ = τ is the coefficient to be estimated and $POP_{t,y,SPK}$ is the interpolated population level in month t , in year y , for Spokane. The monthly interpolation of historical data assumes that between years, population accumulates following the standard population growth model: $POP_{y,SPK} = POP_{y-1,SPK} e^r$.

$\omega_{SD} D_{t,y}$ = ω_{SD} is a vector of seasonal dummy (SD) coefficients to be estimated and $D_{t,y}$ is a vector monthly seasonal dummies to account of customer seasonality. $D_{t,y} = 1$ for the relevant month.

$\omega_{OL} D_{Oct\ 2015=1}$ = ω_{OL} outlier (OL) coefficient to be estimated and D is a dummy that equals 1 for October 2015. There are three additional outlier dummies that follow August 2010. In some cases, the dummy variable may be a structural change (SC) dummy that takes the form, for example, $\omega_{SC} D_{Oct\ 2015=1}$; in this case, the dummy takes the value of 1 for October 2015 forward.

$ARIMA_{t,y}(12,1,0)(0,0,0)_{12}$ = is the error correction applied to the model's initial error structure. This term follows the following from $ARIMA_{t,y}(p,d,q)(p_k,d_k,q_k)_k$. The term p is the autoregressive (AR) order, d is the differencing order, and q is the moving average (MA) order. The term p_k is the order of seasonal AR terms, d_k is the order of seasonal differencing, and q_k is the seasonal order of MA terms. The seasonal values are related to "k," which is the frequency of the data. With the current data set, $k = 12$.

The customer forecast is generated by inputting forecasted values of $POP_{t,y,SPK}$ into the model estimated with historical data. All customer forecast equations are shown in the last section of this appendix.

The above describes the medium-term population forecast to 2025. For IRPs, the medium-term customer forecasts must be extended an additional 15+ years. This is done using the IHS population forecast for Kootenai, Jackson+Josephine, Douglas, Klamath, and Union counties. That is, IHS is the sole source for forecasted population growth beyond the medium-term forecast horizon by [10] through [12]. In the case of Spokane County, the forecast from Washington's Office of Financial Management (OFM) is instead of IHS's. The choice to use OFM's forecasts reflects the unusually sharp changes that have occurred in the IHS forecasts for the Spokane MSA over a short period of time. Figure 9 shows how much these forecasts have changed in level and shape since June 2012. From the October 2015 to March 2018 forecasts, there were significant changes for the 2015-2025 period. There is no clear rationale for why IHS's forecasts changed so significantly between 2012 and 2018. For firm schedules without explicit regression drivers like population, the forecast model run to cover the entire forecast period of the IRP.

Figure 9: Spokane MSA Forecast Comparison

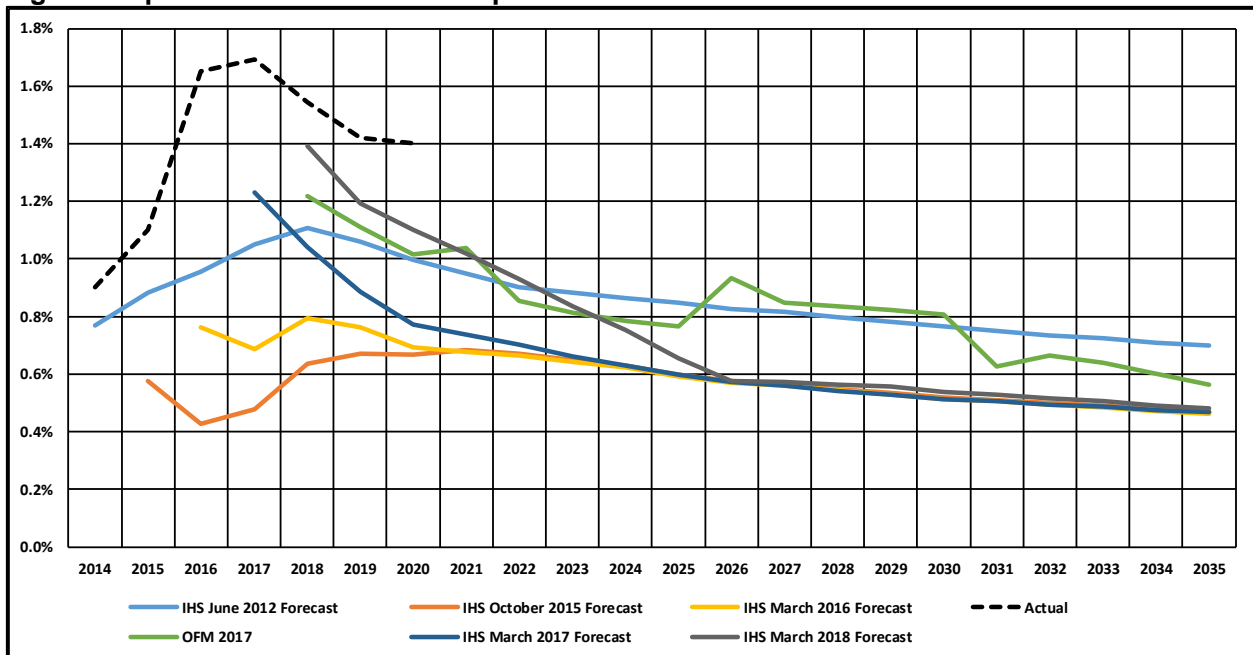

Data source: IHS, Washington State of Office of Financial Management, and U.S. Census.

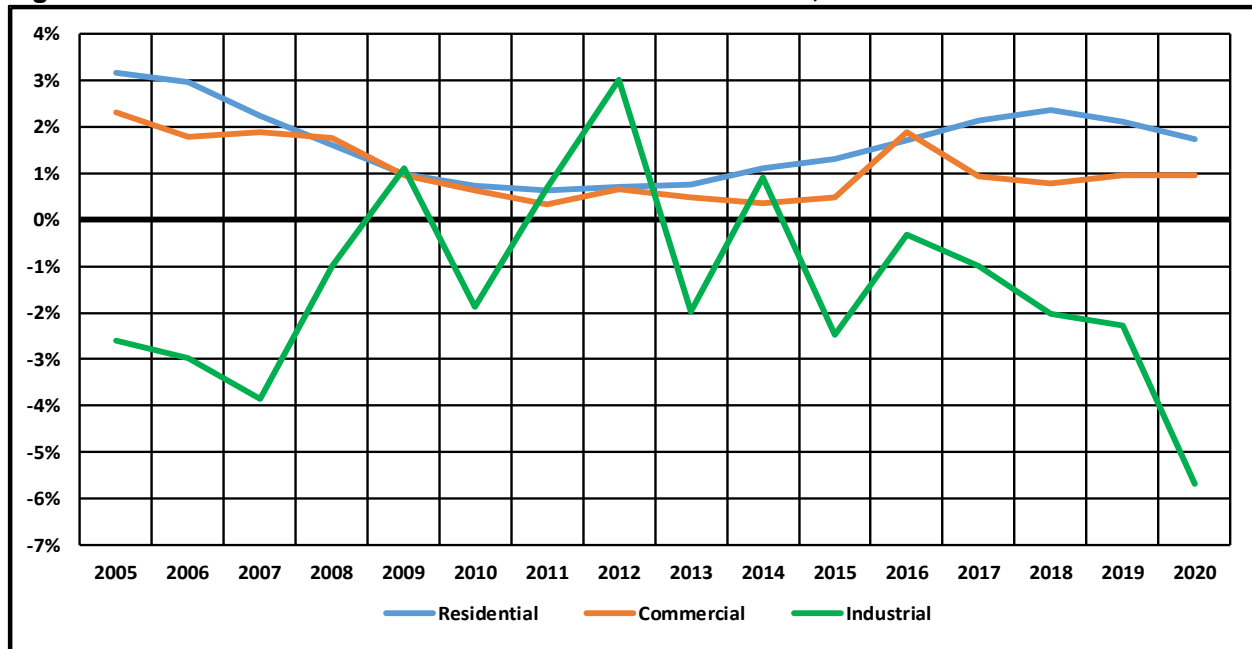
Figure 10: Annual Customer Growth for the Three Rate Classes, 2005-2020

Data source: Company data.

Figure 10 demonstrates that residential and commercial growth rates are highly correlated over the long-run. Over the period shown, residential and commercial averaged about 1.6% and 1.1%, respectively. Residential growth is, on average, higher than population growth because of existing households converting to natural gas at the same time new construction is installing gas. However, by 2009, with the Great Recession and increased natural gas saturation, the different between customer growth and population growth almost disappears. As the economy improved in the 2015-2019 period, residential and commercial growth accelerated due to an improved economy and gas conversion incentives in Washington in the 2016-2019 period.

In contrast, the behavior of Industrial customer growth looks quite different. Customer growth is both lower and more volatile. The average growth rate since 2005 is -1.4%, reflecting a trend of nearly flat or slowly declining customers, depending on the jurisdiction. In addition, the standard deviation of year-over-year growth is 2% compared to 0.8% for residential and 0.6% for commercial growth. The current IRP forecast reflects this historical trend of weak growth.

Establishing High-Low Cases for IRP Customer Forecast

The customer forecasts for this IRP include high and low cases that set the expected bounds around the base-case. Table 2 shows the base, low, and high customer forecasts along with the underlying population growth assumption. The underlying population forecast is the primary driver for each of the three cases.

Table 2: Alternative Growth Cases, 2021-2045

Area	Low Growth	Base Growth	High Growth
WA-ID:			
WA-ID Customers	0.7%	1.1%	1.5%
WA Population	0.4%	0.7%	1.0%
ID Population	0.8%	1.4%	2.0%
OR:			
OR Customers	0.5%	0.7%	0.9%
OR Population	0.3%	0.5%	0.7%
System:			
System Customers	0.6%	1.0%	1.3%
System Population	0.4%	0.8%	1.1%

III. IRP Customer Forecast Equations

1. WA residential customer forecast models:

$$[1] C_{t,y,WA101r} = \alpha_0 + \tau POP_{t,y,SPK} + \omega_{SD} D_{t,y} + \omega_{OL} D_{Oct\ 2015=1} + \omega_{OL} D_{Feb\ 2016=1} + \omega_{OL} D_{Mar\ 2018=1} + \omega_{OL} D_{Nov\ 2018=1} + ARIMA\epsilon_{t,y}(12,1,0)(0,0,0)_{12}$$

[1] Model notes:

1. WA schedule 2 customers are schedule 1 customers that have been moved to a new low-income schedule. The schedule started in October 2015, so there is insufficient data for a more complicated model. In the first years of the program, the number of customers in this schedule started slowly declining under the original cap of 300 customers. However, this schedule has had its cap removed and the number of customers has started to increase. In the spring 2020 forecast the average $\Delta = 6.6$.

$$[2] C_{t,y,WA102r} = C_{t-1} + \Delta, \text{ where } \Delta = \frac{\sum(C_{t,y} - C_{t-1,y})}{N} \text{ for } N \text{ months between October 2015 – May 2020}$$

[2] Model notes:

1. WA schedule 102 customers are schedule 101 customers that have been moved to a new low-income schedule. The schedule started in October 2015, so there is insufficient data for a more complicated model. In the first years of the program, the number of customers in this schedule started slowly declining under the original cap of 300 customers. However, this schedule has had its cap removed and the number of customers has started to increase. In the spring 2020 forecast the average $\Delta = 3.4$.

$$[3] C_{t,y,WA111r} = \alpha_0 + \omega_{SC} D_{Oct\ 2011=1} + \omega_{SC} D_{Oct\ 2013=1} + ARIMA\epsilon_{t,y}(8,1,0)(0,0,0)_{12}$$

[3] Model notes:

1. Error structure white noise, but not quite normally distributed.
2. SC dummies control for a step-up in customers starting in October 2011 and October 2013.

2. ID residential customer forecast models:

$$[4] C_{t,y,ID101r} = \beta_0 + \tau POP_{t,y,KOOT} + \omega_{SD} D_{t,y} + \omega_{SC} D_{Jan\ 2007=1} + Y_{RAMP} T_{Jan\ 2007} + \omega_{OL} D_{May\ 2005=1} + \omega_{OL} D_{Jul\ 2005=1} + \omega_{OL} D_{Oct\ 2005=1} + \omega_{OL} D_{Dec\ 2005=1} + \omega_{OL} D_{Jun\ 2006=1} + \omega_{OL} D_{Jan\ 2006=1} + \omega_{OL} D_{Jun\ 2007=1} + \omega_{OL} D_{Nov\ 2007=1} + \omega_{OL} D_{Aug\ 2011=1} + \omega_{OL} D_{Sept\ 2011=1} + \omega_{OL} D_{Oct\ 2018=1} + ARIMA\epsilon_{t,y}(9,1,0)(0,0,0)_{12}$$

[4] Model notes:

1. SC dummy and ramping time trend control for a change in the time-path of customer growth starting in January 2007.
2. The large number of OL dummies controls for a range of factors including changes in billing cycles, billing errors, and software changes.

$$[5] C_{t,y,ID111.r} = \frac{1}{12} \sum_{j=1}^{12} C_{t-j}$$

[5] Model notes:

1. Model changed to a 12-month moving average in fall 2020. There has been no customer growth since 2012.

3. WA commercial customer forecast models:

$$[6] C_{t,y,WA101.c} = \alpha_0 + \alpha_1 POP_{t,y,SPK} + \omega_{SD} D_{t,y} + \gamma_{RAMP} T_{Jan\ 2010} + \omega_{OL} D_{Nov\ 2005=1} + \omega_{OL} D_{Feb\ 2007=1} + \omega_{OL} D_{Sep\ 2013=1} + \omega_{OL} D_{Oct\ 2013=1} + \omega_{OL} D_{Dec\ 2015=1} + \omega_{OL} D_{Feb\ 2016=1} + \omega_{OL} D_{Jun\ 2017=1} + \omega_{OL} D_{Oct\ 2019=1} + \psi COVIDD_{Apr-Jul\ 2020=1} + ARIMA\epsilon_{t,y}(2,1,0)(0,0,0)_{12}$$

[6] Model notes:

1. In the June 2017 forecast, $C_{t,y,WA101.r}$ (residential customers from residential schedule 101) was replaced with POP for Spokane. This was done to account for a new hookup tariff for residential gas customers in WA's LEAP program. This tariff is more generous than the previous long-standing tariff. In addition, any savings in the hookup process could be passed on to the customer for equipment purchases or replacement. Since this tariff change excluded commercial and industrial customers, this significantly accelerated residential hookups but not commercial hookups. As a result, this historical relationship between residential and commercial customer growth has been altered. See also Tables 5.1 and 5.2.
2. RAMP variable was added in June 2019 because of increasing evidence that the sensitivity of commercial customer growth to population growth fell after 2009.
3. COVIDD dummy controls for the impact of the shut-down shock.

$$[7] C_{t,y,WA111.c} = \alpha_0 + \omega_{SD} D_{t,y} + \gamma_{RAMP} T_{Apr\ 2016} + \gamma_{RAMP} T_{Mar\ 2018} + \omega_{SC} D_{Nov\ 2011=1} + \omega_{SC} D_{Apr\ 2016=1} + \omega_{OL} D_{Jan\ 2007=1} + \omega_{OL} D_{Oct\ 2013=1} + \omega_{OL} D_{Nov\ 2013=1} + \omega_{OL} D_{Jun\ 2017=1} + \omega_{OL} D_{Mar\ 2018=1} + \omega_{OL} D_{Sep\ 2018=1} + \omega_{OL} D_{Oct\ 2018=1} + \omega_{OL} D_{Sep\ 2019=1} + \omega_{OL} D_{Oct\ 2019=1} + ARIMA\epsilon_{t,y}(1,1,0)(0,0,0)_{12}$$

[7] Model notes:

1. SC dummies and RAMP variables control for a complex set of steps and slope changes in the customer count.

4. ID commercial customer forecast models:

$$[8] C_{t,y,ID101.c} = \beta_0 + \beta_1 POP_{t,y,Koot} + \omega_{SC} D_{Nov\ 2005=1} + \omega_{SC} D_{Sep\ 2006=1} + \omega_{SC} D_{Nov\ 2007=1} + \omega_{OL} D_{Mar\ 2005=1} + \omega_{OL} D_{Jun\ 2005=1} + \omega_{OL} D_{Oct\ 2005=1} + \omega_{OL} D_{Dec\ 2005=1} + \omega_{OL} D_{Mar\ 2007=1} + \omega_{OL} D_{Dec\ 2015=1} + \omega_{OL} D_{Sep\ 2018=1} + \omega_{OL} D_{Oct\ 2018=1} + ARIMA\epsilon_{t,y}(9,1,0)(3,1,0)_{12}$$

[8] Model notes:

1. In the spring 2020 forecast, $C_{t,y,ID101.r}$ (residential customers from residential schedule 101) was replaced with POP for Kootenai. This was done because POP produced a model with improved diagnostic tests. Previously, $C_{t,y,ID101.r}$ was being used as a forecast driver because of the historical positive correlation between residential and commercial customer growth. See Tables 5.1 and 5.2.
2. SC dummies control for a step-up in customers in November 2005, September 2006, and November 2007.

$$[9] C_{t,y,ID111.c} = \beta_0 + \gamma_{RAMP} T_{Jan\ 2012} + \omega_{SC} D_{Nov\ 2008=1} + \omega_{SC} D_{Nov\ 2011=1} + \omega_{SC} D_{Jan\ 2012=1} + \omega_{OL} D_{Sep\ 2009=1} + \omega_{OL} D_{Feb\ 2011=1} + \omega_{OL} D_{Feb\ 2015=1} + \omega_{OL} D_{Dec\ 2015=1} + ARIMA\epsilon_{t,y}(1,1,0)(0,0,0)_{12}$$

[9] Model notes:

1. SC dummies control for a large step-up in customers starting in November 2008 and November 2011.
2. Ramping time trend and SC dummy starting in Jan 2012 control for a slowdown in customer growth.

5. WA industrial customer forecasts models:

$$[10] C_{t,y,WA101.i} = \alpha_0 + \omega_{SC} D_{Apr\ 2008=1} + \omega_{SC} D_{Oct\ 2013=1} + \omega_{OL} D_{Oct\ 2006=1} + \omega_{OL} D_{Jan\ 2007=1} + \omega_{OL} D_{Feb\ 2007=1} + \omega_{OL} D_{Dec\ 2013=1} + \omega_{OL} D_{Jan\ 2015=1} + \omega_{OL} D_{Mar\ 2017=1} + ARIMA\epsilon_{t,y}(7,1,0)(0,0,0)_{12}$$

[10] Model notes:

1. SC dummies control for a step-down in customers starting in April 2008 and October 2013.

$$[11] C_{t,y,WA111.i} = ARIMA(2,1,0)(0,0,0)_{12}$$

[11] Model notes:

1. Error structure is white noise, but not quite normally distributed.
2. In January 2019, all three customers in schedule 121 industrial were moved to schedule 111, in addition to Boise Cascade A rden, WA (under the company name Columbia Cedar) from schedule 25. This change of four customers falls within the normal variation of customers in schedule 111; therefore, no explicit adjustment is made to the model [7.40] to account for this shift.

6. ID industrial customer forecast models:

$$[12] C_{t,y,ID101.i} = \beta_0 + \omega_{SC} D_{Dec\ 2010\uparrow=1} + \omega_{SC} D_{Nov\ 2011\uparrow=1} + \omega_{SC} D_{Dec\ 2011\uparrow=1} + \omega_{SC} D_{Jun\ 2014\uparrow=1} + \omega_{SC} D_{Jan\ 2018\uparrow=1} + \omega_{OL} D_{Dec\ 2008=1} + \omega_{OL} D_{Jul\ 2014=1} + \omega_{OL} D_{Jan\ 2015=1} + \omega_{OL} D_{Jan\ 2016=1} + \omega_{OL} D_{Feb\ 2017=1} + ARIMA\epsilon_{t,y}(13,1,0)(0,0,0)_{12}$$

[12] Model notes:

1. SC dummies control for step-downs in customers starting in December 2010, November 2011, December 2011, and January 2018; June 2014 controls for a step-up in customers.
2. The large number of OL dummies controls for a range of factors including changes in billing cycles, billing errors, and software changes.

$$[13] C_{t,y,ID111.i} = \frac{1}{12} \sum_{j=1}^{12} C_{t-j}$$

[13] Model notes:

1. Period of restriction reflects the restriction on the UPC model for this schedule.
2. Customer count stabilized in 2012; customer count fluctuates between 31 and 34 without any clear trend or seasonality.

$$[14] C_{t,y,ID112.i} = \frac{1}{12} \sum_{j=1}^{12} C_{t-j}$$

[14] Model notes:

1. Customer count tends to increase in steps following prolonged periods of stability. No clear seasonality present.

7. Medford, OR forecasting models:

The forecasting models for the Medford region (Jackson County) are given below for the residential, commercial, and industrial sectors:

Residential Sector, Customers:

$$[15] C_{t,y,MED410.r} = \alpha_0 + \alpha_1 POP_{t,y,JACK+JOS} + \omega_{SD} D_{t,y} + \gamma_{RAMP} T_{Jan\ 2008} + \omega_{SC} D_{Jan\ 2008\uparrow=1} + \omega_{SC} D_{Nov\ 2004\uparrow=1} + \omega_{OL} D_{Dec\ 2005=1} + ARIMA\epsilon_{t,y}(7,1,0)(0,0,0)_{12}$$

[15] Model notes:

1. SC dummy and ramping time trend control for a change in the time-path of customer growth starting in January 2008.
2. POP is Jackson plus Josephine counties.

Commercial Sector, Customers:

$$[16] C_{t,y,MED420.c} = \alpha_0 + \alpha_1 C_{t,y,MED410.r} + \omega_{SD} D_{t,y} + \omega_{OL} D_{Nov\ 2009=1} + \omega_{OL} D_{Jan\ 2016=1} + \psi_{COVIDD} D_{Apr-Jul\ 2020=1} + ARIMA\epsilon_{t,y}(7,1,0)(0,0,0)_{12}$$

[16] Model notes:

1. $C_{t,y,MED410.r}$ are residential customers from residential schedule 410. They are being used as a forecast driver because of the historical positive correlation between residential and commercial customer growth. See Tables 5.1 and 5.2. However, in the future, POP may become a better driver. Model results with POP are fairly close to model shown above.
2. COVIDD dummy controls for the impact of the shut-down shock.

$$[17] C_{y,MED424.c} = C_{y-1} + (\hat{\alpha}_0 + \hat{\alpha}_1 \Delta EMP_{y-1,4County})$$

[17] Model notes:

1. This model reflects a recommendation by Oregon staff in the 2016 rate case to include employment as an economic driver for schedule 424 commercial customers. The estimated equation in parenthesis reflects the regression estimated of $\Delta C_{y,MED424.c} = \alpha_0 + \alpha_1 \Delta EMP_{y-1,4County} + \varepsilon_t$ using annual customer data since 2004. Annual data is used to smooth over the sometimes volatile changes in the monthly customer number. In addition, customer increases and decreases around the long-run trend tend to occur in steps. The combination of steps and month-to-month volatility creates significant economic problems when trying to model around the monthly data. For example, even with intervention variables, tests for error normality always indicated non-normal error terms with the use of monthly data.
2. $\Delta C_{y,MED424.c}$ is the change in customers in year y (customer change between year y and y-1) and $\Delta EMP_{y-1,4County}$ is the change in total non-farm employment in Jackson, Josephine, Klamath, and Douglas counties in year y-1 (employment change between year y-1 and y-2). Staff originally suggested lagged total employment for Oregon, but the correlation between schedule 424 customers and employment for the three-county area is higher. The forecasted employment values for Jackson+Josephine County are derived from the employment growth forecasts used in the Jackson+Josephine County population forecast. The forecasts for Douglas and Klamath counties come from IHS. In IRP years, IHS forecasts all counties will be used for the out years.
3. The annual forecast value for each year, $F(\cdot)$, is assumed to hold for each month of that year. That is: $F(C_{y,MED424.c}) = F(C_{t,y,MED424.c})$. Given the step-like behavior of the monthly series, this is a reasonable assumption.
4. The forecast and regressions for this schedule can be found in the Excel file folder "OR 4County Sch 424c Cus."

$$[18] C_{t,y,MED444.c} = 1 \text{ if } (THM/C_{t,y})_{MED,444.c} > 0$$

[19] Model notes:

1. There is typically only one customer served by this schedule. Therefore, the customer forecast is automatically set to on whenever the load forecast is greater than zero. In IRP years, the forecast is repeated out monthly until December 2045.

Industrial Sector, Customers:

$$[19] C_{t,y,MED420.i} = \frac{1}{12} \sum_{j=1}^{12} C_{t-j}$$

[19] Model notes:

1. Data starts November 2006. Excluding outliers in November 2006, November 2009, and February 2011, the customer count fluctuates between 9 and 16 without any clear trend or seasonality. Changes in the customer count occur in steps between prolonged periods of stability.

$$[20] C_{t,y,MED424.i} = \frac{1}{12} \sum_{j=1}^{12} C_{t-j}$$

[20] Model notes:

1. Data starts January 2009. Excluding a January 2009 outlier, the customer count fluctuates between 1 and 3 without any clear trend or seasonality. Customer count is most frequently reported as 2; however, starting in March 2018, the customer count fell to one.

8. Roseburg, OR forecasting models:

The forecasting models for the Roseburg region (Douglas County) are given below for the residential, commercial, and industrial sectors:

Residential Sector, Customers:

$$[21] C_{t,y,ROS410.r} = \varphi_0 + \varphi_1 POP_{t,y,DOUGLAS} + \omega_{SD} D_{t,y} + \omega_{SC} D_{Jan\ 2005 \uparrow = 1} + \omega_{SC} D_{Dec\ 2005 \uparrow = 1} + \omega_{SC} D_{Nov\ 2006 \uparrow = 1} + \omega_{OL} D_{Oct\ 2004 = 1} + \omega_{OL} D_{Nov\ 2004 = 1} + \omega_{OL} D_{Dec\ 2007 = 1} + \omega_{OL} D_{Feb\ 2008 = 1} + \omega_{OL} D_{Nov\ 2009 = 1} + \omega_{OL} D_{Oct\ 2018 = 1} + \omega_{OL} D_{Mar\ 2019 = 1} + ARIMA_{\epsilon_{t,y}}(12,1,0)(0,0,0)_{12}$$

[21] Model notes:

1. POP is population for Douglas County, OR.
2. SC dummies control for large step-ups in customers in 2005 and 2006.

Commercial Sector, Customers:

$$[22] C_{t,y,ROS420.c} = \varphi_0 + \varphi_1 POP_{t,y,DOUGLAS} + \omega_{SD} D_{t,y} + \omega_{SC} D_{Dec\ 2004=1} + \omega_{OL} D_{Nov\ 2004=1} + \omega_{OL} D_{Jan\ 2005=1} + \omega_{OL} D_{Jan\ 2008=1} + \omega_{OL} D_{May\ 2016=1} + \omega_{OL} D_{Mar\ 2019=1} + \omega_{OL} D_{Sept\ 2019=1} + \omega_{OL} D_{Oct\ 2019=1} + \psi COVIDD_{Apr-Jul\ 2020=1} + ARIMA\epsilon_{t,y}(9,1,0)(0,0,0)_{12}$$

[22] Model notes:

1. Model does not use schedule 410 customers as driver. This reflects the lack of correlation between residential 410 and commercial 420 customer growth. However, POP was added for the 2018 gas IRP and it is significant at the 10% level
2. The lack of correlation noted in Point 1 could reflect Roseburg's position between larger cities that offer a range of commercial activities. Competition from these cities may be inhibiting commercial growth in Roseburg.
3. SC dummy controls for a significant step-up in customers starting in December 2004.
4. COVIDD dummy controls for the impact of the shut-down shock.

$$[23] C_{t,y,ROS424.c} = C_{y-1} + (\widehat{\varphi}_0 + \widehat{\varphi}_1 \Delta EMP_{y-1,4County})$$

[23] Model notes:

1. This model reflects a recommendation by Oregon staff in the 2016 rate case to include employment as an economic driver for schedule 424 commercial customers. The estimated equation in parenthesis reflects the regression estimated of $\Delta C_{y,ROS424.c} = \alpha_0 + \alpha_1 \Delta EMP_{y-1,4County} + \varepsilon_t$ using annual customer data since 2004. Annual data is used to smooth over the sometimes volatile changes in the monthly customer number. In addition, customer increases and decreases around the long-run trend tend to occur in steps. The combination of steps and month-to-month volatility creates significant economic problems when trying to model around the monthly data. For example, even with intervention variables, tests for error normality always indicated non-normal error terms with the use of monthly data.
2. $\Delta C_{y,ROS424.c}$ is the change in customers in year y (customer change between year y and y-1) and $\Delta EMP_{y-1,4County}$ is the change in total non-farm employment in Jackson, Josephine, Klamath, and Douglas counties in year y-1 (employment change between year y-1 and y-2). Staff originally suggested lagged total employment for Oregon, but the correlation between schedule 424 customers and employment for the three-county area is higher. The forecasted employment values for Jackson+Josephine County are derived from the employment growth forecasts used in the Jackson+Josephine County population forecast. The forecasts for Douglas and Klamath counties come from IHS. In IRP years, IHS forecasts for all counties will be used for the out years.
3. The annual forecast value for each year, $F(\cdot)$, is assumed to hold for each month of that year. That is: $F(C_{y,ROS424.c}) = F(C_{t,y,ROS424.c})$. Given the step-like behavior of the monthly series, this is a reasonable assumption.
4. The forecast and regressions for this schedule can be found in the Excel file folder "OR 4County Sch 424c Cus."

Industrial Sector, Customers:

$$[24] C_{t,y,ROS420.i} = \frac{1}{12} \sum_{j=1}^{12} C_{t-j}$$

[24] Model notes:

1. Data starts September 2009. Excluding a February 2015 outlier, the customer count fluctuates between 1 and 2 without any clear trend or seasonality.
2. Due to the Compass software conversion, February 2015 is excluded from the historical data. The conversion resulted in a double counting of customers in February 2015. Therefore, including this month leads to a significant over-forecast of customers.

9. Klamath Falls, OR forecasting models:

The forecasting models for the Klamath Falls region (Klamath County) are given below for the residential, commercial, and industrial sectors:

Residential Sector, Customers:

$$[25] C_{t,y,KLM410.r} = \beta_0 + \beta_1 POP_{t,y,KLAMATH} + \omega_{SD} D_{t,y} + \omega_{OL} D_{Apr\ 2015=1} + ARIMA\epsilon_{t,y}(7,1,0)(0,0,0)_{12}$$

[25] Model notes:

1. POP is for Klamath County, OR.

Commercial Sector, Customers:

$$[26] C_{t,y,KLM420.c} = \beta_0 + \beta_1 C_{t,y,KLM410.r} + \omega_{SD} D_{t,y} + \omega_{OL} D_{Oct\ 2006=1} + ARIMA \epsilon_{t,y} (11,1,0)(1,0,0)_{12}$$

[26] Model notes:

1. $C_{t,y,KLM410.r}$ are residential customers from residential schedule 410. They are being used as a forecast driver because of the historical positive correlation between residential and commercial customer growth. See Tables 5.1 and 5.2. However, in as of the June 2019 forecast, the coefficient on $C_{t,y,KLM410.r}$ is positive but no longer statistically significant.

$$[27] C_{t,y,KLM424.c} = C_{y-1} + (\beta_0 + \beta_1 \Delta EMP_{y-1,4County})$$

[27] Model notes:

1. This model reflects a recommendation by Oregon staff in the 2016 rate case to include employment as an economic driver for schedule 424 commercial customers. The estimated equation in parenthesis reflects the regression estimated of $\Delta C_{y,KLM424.c} = \alpha_0 + \alpha_1 \Delta EMP_{y-1,4County} + \epsilon_t$ using annual customer data since 2004. Annual data is used to smooth over the sometimes volatile changes in the monthly customer number. In addition, customer increases and decreases around the long-run trend tend to occur in steps. The combination of steps and month-to-month volatility creates significant economic problems when trying to model around the monthly data. For example, even with intervention variables, tests for error normality always indicated non-normal error terms with the use of monthly data.
2. $\Delta C_{y,KLM424.c}$ is the change in customers in year y (customer change between year y and y-1) and $\Delta EMP_{y-1,4County}$ is the change in total non-farm employment in Jackson, Josephine, Klamath, and Douglas counties in year y-1 (employment change between year y-1 and y-2). Staff originally suggested lagged total employment for Oregon, but the correlation between schedule 424 customers and employment for the three-county area is higher. The forecasted employment values for Jackson+Josephine County are derived from the employment growth forecasts used in the Jackson+Josephine County population forecast. The forecasts for Douglas and Klamath counties come from IHS. In IRP years, IHS forecasts for all counties will be used for the out years.
3. The annual forecast value for each year, $F(\cdot)$, is assumed to hold for each month of that year. That is: $F(C_{y,KLM424.c}) = F(C_{t,y,KLM424.c})$. Given the step-like behavior of the monthly series, this is a reasonable assumption.
4. The forecast and regressions for this schedule can be found in the Excel file folder "OR 4County Sch 424c Cus."

Industrial Sector, Customers:

Industrial Sector, Customers:

$$[28] C_{t,y,KLM420.i} = \frac{1}{12} \sum_{j=1}^{12} C_{t-j}$$

[28] Model notes:

1. Data starts December 2006. The customer count fluctuates between 4 and 9 without any clear trend or seasonality.

$$[29] C_{t,y,KLM424.i} = \frac{1}{12} \sum_{j=1}^{12} C_{t-j}$$

[29] Model notes:

1. Data starts April 2009. The customer count fluctuates between 1 and 4 without any clear trend or seasonality.

10. La Grande, OR forecasting models:

The forecasting models for the La Grande region (Union County) are given below for the residential, commercial, and industrial sectors:

Residential Sector, Customers:

$$[30] C_{t,y,LaG410.r} = \theta_0 + \theta_1 POP_{t,y,UNION} + \omega_{SD} D_{t,y} + \omega_{OL} D_{Oct\ 2004=1} + \omega_{OL} D_{Jul\ 2006=1} + \omega_{OL} D_{Dec\ 2009=1} + ARIMA \epsilon_{t,y} (9,1,0)(1,0,0)_{12}$$

[30] Model notes:

1. POP is population for Union County, OR.

Commercial Sector, Customers:

$$[31] C_{t,y,LaG424.c} = \frac{1}{12} \sum_{j=1}^{12} C_{t-j}$$

[31] Model notes:

1. Data starts January 2007. The customer count fluctuates between 2 and 4 without any clear trend or seasonality. Changes in the customer count appear as steps after prolonged periods of stability.

Industrial Sector, Customers:

$$[7.32] C_{t,y,LaG440.i} = \frac{1}{N} \sum_{j=1}^N C_{t,y-j} \text{ for } y-j = 2012 \uparrow \text{ up to the end of the nearest calendar year.}$$

[7.32] Model notes:

1. Even in the presence of some seasonality, customer count can be highly erratic. Regression models produced poor diagnostics. As a result, a historical monthly average is used as the forecast.
2. Restricted to 2012 \uparrow because of a significant change in behavior starting in 2012.

$$[7.31] C_{t,y,LaG444.i} = \theta_0 + \omega_{SD} D_{t,y} + \omega_{OL} D_{Aug\ 2007=1} + \omega_{OL} D_{Nov\ 2009=1} + \omega_{OL} D_{Nov\ 2010=1} \\ + \omega_{OL} D_{Aug\ 2012=1} + \omega_{OL} D_{Nov\ 2012=1} + \omega_{OL} D_{Dec\ 2012=1} + \omega_{OL} D_{Jan\ 2013=1} + \omega_{OL} D_{Feb\ 2013=1} + \omega_{OL} D_{Jan\ 2014=1} + \\ \omega_{OL} D_{Oct\ 2015=1} + ARIMA\epsilon_{t,y}(10,0,0)(2,0,0)_{12}$$

APPENDIX 2.2: CUSTOMER FORECASTS BY REGION WASHINGTON

	Washington - Expected Growth			Washington - High Growth			Washington - Low Growth		
	Residential Customers	Commercial Customers	Industrial Customers	Residential Customers	Commercial Customers	Industrial Customers	Residential Customers	Commercial Customers	Industrial Customers
Nov-19	154,755	14,895	127	154,755	14,895	127	154,755	14,895	127
Dec-19	155,069	14,979	130	155,069	14,979	130	155,069	14,979	130
Jan-20	155,673	15,064	128	155,673	15,064	128	155,673	15,064	128
Feb-20	155,515	14,935	127	155,515	14,935	127	155,515	14,935	127
Mar-20	155,696	15,017	128	155,696	15,017	128	155,696	15,017	128
Apr-20	155,821	15,032	129	155,821	15,032	129	155,821	15,032	129
May-20	155,314	14,858	126	155,314	14,858	126	155,314	14,858	126
Jun-20	155,434	14,877	127	156,228	14,953	126	154,678	14,805	126
Jul-20	155,600	14,854	127	156,416	14,932	127	154,825	14,780	126
Aug-20	155,568	14,959	126	156,404	15,039	127	154,774	14,883	125
Sep-20	155,782	14,958	126	156,639	15,040	127	154,967	14,880	125
Oct-20	156,075	14,955	127	156,954	15,039	127	155,240	14,875	125
Nov-20	156,556	14,974	127	157,458	15,060	128	155,698	14,892	125
Dec-20	156,921	15,048	126	157,846	15,137	128	156,043	14,964	124
Jan-21	157,115	15,059	127	158,061	15,150	128	156,216	14,973	124
Feb-21	157,078	15,071	126	158,045	15,164	128	156,160	14,983	124
Mar-21	157,076	15,073	126	158,063	15,168	129	156,138	14,983	124
Apr-21	156,831	15,043	126	157,837	15,140	129	155,876	14,951	123
May-21	156,731	15,023	126	157,757	15,121	129	155,757	14,930	123
Jun-21	156,566	15,023	126	157,612	15,123	129	155,574	14,928	123
Jul-21	156,686	15,004	126	157,782	15,109	130	155,645	14,904	123
Aug-21	156,845	15,007	126	157,993	15,117	130	155,756	14,903	122
Sep-21	157,068	15,008	126	158,268	15,123	130	155,930	14,899	122
Oct-21	157,472	15,006	126	158,726	15,125	130	156,283	14,893	122
Nov-21	158,031	15,027	126	159,341	15,152	131	156,790	14,909	122
Dec-21	158,443	15,103	126	159,807	15,233	131	157,151	14,980	121
Jan-22	158,743	15,116	126	160,160	15,251	131	157,400	14,988	121
Feb-22	158,743	15,129	126	160,211	15,269	131	157,352	14,996	121
Mar-22	158,741	15,132	125	160,261	15,277	132	157,302	14,995	121
Apr-22	158,689	15,104	125	160,260	15,253	132	157,202	14,963	120
May-22	158,658	15,087	125	160,280	15,241	132	157,124	14,941	120
Jun-22	158,497	15,089	125	160,168	15,248	132	156,917	14,939	120
Jul-22	158,668	15,070	125	160,397	15,234	133	157,034	14,915	120
Aug-22	158,824	15,074	125	160,610	15,244	133	157,136	14,914	119
Sep-22	159,064	15,074	125	160,908	15,249	133	157,321	14,909	119
Oct-22	159,486	15,073	125	161,392	15,253	133	157,686	14,903	119
Nov-22	160,056	15,093	125	162,025	15,279	134	158,197	14,918	119
Dec-22	160,496	15,170	125	162,527	15,362	134	158,580	14,989	118
Jan-23	160,788	15,183	125	162,879	15,380	134	158,815	14,997	118
Feb-23	160,780	15,197	125	162,927	15,400	134	158,754	15,006	118

	Washington - Expected Growth			Washington - High Growth			Washington - Low Growth		
	Residential Customers	Commercial Customers	Industrial Customers	Residential Customers	Commercial Customers	Industrial Customers	Residential Customers	Commercial Customers	Industrial Customers
Mar-23	160,822	15,200	124	163,027	15,408	135	158,743	15,004	118
Apr-23	160,793	15,172	124	163,054	15,385	135	158,662	14,971	117
May-23	160,753	15,155	124	163,071	15,373	135	158,570	14,949	117
Jun-23	160,611	15,159	124	162,983	15,383	135	158,377	14,948	117
Jul-23	160,800	15,139	124	163,238	15,369	136	158,504	14,923	117
Aug-23	160,969	15,144	124	163,474	15,380	136	158,612	14,922	116
Sep-23	161,228	15,144	124	163,800	15,386	136	158,808	14,917	116
Oct-23	161,669	15,143	124	164,313	15,391	136	159,183	14,910	116
Nov-23	162,263	15,165	124	164,980	15,419	137	159,708	14,926	116
Dec-23	162,713	15,241	124	165,502	15,502	137	160,091	14,995	115
Jan-24	163,012	15,255	124	165,871	15,523	137	160,326	15,004	115
Feb-24	163,031	15,269	124	165,955	15,543	137	160,285	15,012	115
Mar-24	163,096	15,273	124	166,086	15,553	138	160,290	15,010	115
Apr-24	163,078	15,245	123	166,132	15,531	138	160,212	14,977	114
May-24	163,057	15,229	123	166,175	15,520	138	160,131	14,956	114
Jun-24	162,932	15,232	123	166,113	15,529	138	159,950	14,953	114
Jul-24	163,104	15,212	123	166,345	15,514	139	160,065	14,929	114
Aug-24	163,258	15,217	123	166,560	15,525	139	160,164	14,929	113
Sep-24	163,504	15,217	123	166,868	15,530	139	160,353	14,924	113
Oct-24	163,935	15,216	123	167,365	15,534	139	160,722	14,918	113
Nov-24	164,510	15,237	123	168,011	15,561	140	161,233	14,933	113
Dec-24	164,941	15,313	123	168,509	15,644	140	161,602	15,003	112
Jan-25	165,228	15,327	123	168,861	15,664	140	161,830	15,012	112
Feb-25	165,234	15,341	123	168,925	15,684	140	161,783	15,021	112
Mar-25	165,284	15,344	123	169,033	15,692	141	161,778	15,019	112
Apr-25	165,251	15,315	122	169,059	15,668	141	161,693	14,985	111
May-25	165,215	15,299	122	169,080	15,657	141	161,604	14,965	111
Jun-25	165,074	15,302	122	168,994	15,665	141	161,414	14,963	111
Jul-25	165,248	15,282	122	169,231	15,650	142	161,530	14,938	111
Aug-25	165,406	15,286	122	169,451	15,660	142	161,630	14,937	110
Sep-25	165,656	15,287	122	169,767	15,666	142	161,821	14,933	110
Oct-25	166,088	15,286	122	170,268	15,671	142	162,189	14,927	110
Nov-25	166,665	15,307	122	170,920	15,698	143	162,699	14,943	110
Dec-25	167,099	15,383	122	171,424	15,781	143	163,068	15,012	109
Jan-26	167,390	15,396	122	171,783	15,800	143	163,298	15,020	109
Feb-26	167,398	15,410	122	171,851	15,820	143	163,251	15,028	109
Mar-26	167,450	15,414	122	171,964	15,830	144	163,247	15,027	109
Apr-26	167,420	15,385	122	171,993	15,805	144	163,164	14,994	108
May-26	167,386	15,369	121	172,018	15,794	144	163,076	14,973	108
Jun-26	167,247	15,372	121	171,935	15,803	144	162,887	14,971	108

	Washington - Expected Growth			Washington - High Growth			Washington - Low Growth		
	Residential Customers	Commercial Customers	Industrial Customers	Residential Customers	Commercial Customers	Industrial Customers	Residential Customers	Commercial Customers	Industrial Customers
Jul-26	167,411	15,352	121	172,158	15,787	145	162,997	14,947	108
Aug-26	167,560	15,355	121	172,365	15,795	145	163,093	14,946	107
Sep-26	167,799	15,356	121	172,666	15,801	145	163,277	14,942	107
Oct-26	168,220	15,355	121	173,154	15,805	145	163,636	14,937	107
Nov-26	168,786	15,375	121	173,792	15,831	146	164,138	14,952	107
Dec-26	169,210	15,451	121	174,283	15,914	146	164,500	15,021	106
Jan-27	169,491	15,464	121	174,628	15,933	146	164,723	15,029	106
Feb-27	169,487	15,478	121	174,679	15,952	146	164,670	15,038	106
Mar-27	169,529	15,482	121	174,778	15,961	147	164,661	15,037	106
Apr-27	169,488	15,453	121	174,791	15,936	147	164,572	15,005	105
May-27	169,443	15,436	121	174,800	15,924	147	164,478	14,984	105
Jun-27	169,295	15,438	120	174,702	15,931	147	164,284	14,981	105
Jul-27	169,457	15,419	120	174,924	15,916	148	164,393	14,958	105
Aug-27	169,605	15,422	120	175,131	15,925	148	164,487	14,957	104
Sep-27	169,843	15,423	120	175,432	15,931	148	164,669	14,953	104
Oct-27	170,264	15,422	120	175,922	15,934	148	165,028	14,948	104
Nov-27	170,830	15,442	120	176,561	15,960	149	165,527	14,963	104
Dec-27	171,253	15,518	120	177,054	16,044	149	165,888	15,032	103
Jan-28	171,533	15,531	120	177,398	16,062	149	166,109	15,040	103
Feb-28	171,529	15,545	120	177,450	16,082	149	166,056	15,049	103
Mar-28	171,570	15,548	120	177,548	16,090	150	166,046	15,047	103
Apr-28	171,529	15,520	120	177,560	16,066	150	165,957	15,016	102
May-28	171,483	15,503	120	177,569	16,053	150	165,863	14,995	102
Jun-28	171,334	15,505	119	177,469	16,060	150	165,669	14,992	102
Jul-28	171,495	15,485	119	177,691	16,044	151	165,777	14,969	102
Aug-28	171,642	15,489	119	177,898	16,054	151	165,870	14,968	101
Sep-28	171,880	15,490	119	178,198	16,059	151	166,051	14,965	101
Oct-28	172,299	15,488	119	178,688	16,062	151	166,408	14,958	101
Nov-28	172,864	15,508	119	179,329	16,088	152	166,904	14,973	101
Dec-28	173,286	15,585	119	179,822	16,173	152	167,263	15,043	100
Jan-29	173,565	15,597	119	180,167	16,190	152	167,483	15,050	100
Feb-29	173,561	15,611	119	180,217	16,210	152	167,429	15,060	100
Mar-29	173,600	15,614	119	180,314	16,218	153	167,419	15,058	100
Apr-29	173,558	15,586	119	180,325	16,194	153	167,329	15,027	99
May-29	173,511	15,569	119	180,332	16,181	153	167,235	15,006	99
Jun-29	173,361	15,572	119	180,231	16,189	153	167,041	15,004	99
Jul-29	173,522	15,551	118	180,452	16,172	154	167,148	14,980	99
Aug-29	173,667	15,555	118	180,658	16,181	154	167,240	14,979	98
Sep-29	173,904	15,556	118	180,959	16,187	154	167,419	14,976	98
Oct-29	174,321	15,554	118	181,448	16,190	154	167,773	14,970	98

	Washington - Expected Growth			Washington - High Growth			Washington - Low Growth		
	Residential Customers	Commercial Customers	Industrial Customers	Residential Customers	Commercial Customers	Industrial Customers	Residential Customers	Commercial Customers	Industrial Customers
Nov-29	174,885	15,575	118	182,089	16,217	155	168,267	14,986	98
Dec-29	175,306	15,651	118	182,582	16,301	155	168,624	15,054	97
Jan-30	175,583	15,664	118	182,926	16,319	155	168,842	15,063	97
Feb-30	175,578	15,677	118	182,976	16,338	155	168,788	15,071	97
Mar-30	175,616	15,680	118	183,071	16,346	156	168,777	15,069	97
Apr-30	175,572	15,652	118	183,080	16,321	156	168,686	15,038	96
May-30	175,524	15,635	118	183,085	16,308	156	168,592	15,017	96
Jun-30	175,372	15,637	118	182,981	16,315	156	168,397	15,015	96
Jul-30	175,509	15,616	118	183,167	16,297	157	168,490	14,992	96
Aug-30	175,629	15,620	117	183,335	16,305	157	168,569	14,992	95
Sep-30	175,841	15,619	117	183,599	16,308	157	168,734	14,988	95
Oct-30	176,233	15,617	117	184,052	16,310	157	169,073	14,982	95
Nov-30	176,772	15,637	117	184,658	16,335	158	169,552	14,998	95
Dec-30	177,169	15,712	117	185,115	16,417	158	169,894	15,067	94
Jan-31	177,420	15,725	117	185,421	16,434	158	170,097	15,076	94
Feb-31	177,390	15,738	117	185,433	16,452	158	170,030	15,085	94
Mar-31	177,403	15,741	117	185,491	16,459	159	170,005	15,085	94
Apr-31	177,335	15,711	117	185,462	16,431	159	169,902	15,052	93
May-31	177,262	15,694	117	185,429	16,417	159	169,794	15,033	93
Jun-31	177,085	15,695	117	185,288	16,422	159	169,587	15,030	93
Jul-31	177,227	15,674	117	185,482	16,404	160	169,682	15,007	93
Aug-31	177,353	15,678	116	185,660	16,412	160	169,763	15,007	92
Sep-31	177,571	15,678	116	185,934	16,416	160	169,931	15,003	92
Oct-31	177,970	15,676	116	186,398	16,418	160	170,272	14,998	92
Nov-31	178,515	15,696	116	187,016	16,443	161	170,754	15,014	92
Dec-31	178,917	15,771	116	187,483	16,526	161	171,097	15,082	91
Jan-32	179,175	15,784	116	187,800	16,544	161	171,304	15,091	91
Feb-32	179,151	15,797	116	187,821	16,562	161	171,240	15,099	91
Mar-32	179,171	15,800	116	187,889	16,569	162	171,218	15,099	91
Apr-32	179,108	15,770	116	187,870	16,541	162	171,118	15,066	90
May-32	179,041	15,754	116	187,846	16,529	162	171,013	15,048	90
Jun-32	178,870	15,755	116	187,713	16,534	162	170,810	15,045	90
Jul-32	179,009	15,735	116	187,904	16,517	163	170,903	15,023	90
Aug-32	179,133	15,738	116	188,078	16,524	163	170,982	15,022	89
Sep-32	179,348	15,737	115	188,350	16,527	163	171,149	15,018	89
Oct-32	179,744	15,736	115	188,810	16,530	163	171,487	15,013	89
Nov-32	180,286	15,755	115	189,425	16,554	164	171,966	15,028	89
Dec-32	180,685	15,830	115	189,890	16,636	164	172,307	15,096	88
Jan-33	180,941	15,843	115	190,204	16,654	164	172,511	15,105	88
Feb-33	180,913	15,856	115	190,220	16,672	164	172,445	15,114	88

	Washington - Expected Growth			Washington - High Growth			Washington - Low Growth		
	Residential Customers	Commercial Customers	Industrial Customers	Residential Customers	Commercial Customers	Industrial Customers	Residential Customers	Commercial Customers	Industrial Customers
Mar-33	180,930	15,859	115	190,283	16,679	165	172,422	15,113	88
Apr-33	180,864	15,830	115	190,260	16,652	165	172,320	15,082	87
May-33	180,795	15,812	115	190,232	16,637	165	172,215	15,062	87
Jun-33	180,622	15,814	115	190,095	16,643	165	172,010	15,060	87
Jul-33	180,755	15,794	115	190,279	16,626	166	172,101	15,038	87
Aug-33	180,874	15,797	115	190,446	16,633	166	172,177	15,037	86
Sep-33	181,083	15,797	115	190,710	16,637	166	172,339	15,034	86
Oct-33	181,475	15,794	114	191,165	16,637	166	172,675	15,028	86
Nov-33	182,012	15,814	114	191,773	16,662	167	173,148	15,044	86
Dec-33	182,405	15,889	114	192,231	16,745	167	173,485	15,112	85
Jan-34	182,656	15,901	114	192,538	16,761	167	173,687	15,120	85
Feb-34	182,623	15,914	114	192,548	16,779	167	173,618	15,129	85
Mar-34	182,635	15,917	114	192,603	16,786	168	173,592	15,129	85
Apr-34	182,565	15,888	114	192,572	16,759	168	173,488	15,098	84
May-34	182,489	15,870	114	192,536	16,744	168	173,379	15,078	84
Jun-34	182,311	15,871	114	192,391	16,749	168	173,173	15,075	84
Jul-34	182,440	15,851	114	192,568	16,731	169	173,261	15,053	84
Aug-34	182,554	15,854	114	192,729	16,738	169	173,334	15,053	83
Sep-34	182,758	15,853	114	192,985	16,740	169	173,493	15,049	83
Oct-34	183,145	15,851	113	193,434	16,742	169	173,825	15,044	83
Nov-34	183,678	15,870	113	194,038	16,765	170	174,295	15,059	83
Dec-34	184,067	15,946	113	194,491	16,849	170	174,630	15,128	82
Jan-35	184,313	15,958	113	194,791	16,865	170	174,827	15,137	82
Feb-35	184,275	15,970	113	194,793	16,881	170	174,756	15,145	82
Mar-35	184,282	15,973	113	194,841	16,888	171	174,727	15,145	82
Apr-35	184,207	15,944	113	194,802	16,861	171	174,621	15,114	81
May-35	184,127	15,926	113	194,760	16,846	171	174,510	15,094	81
Jun-35	183,944	15,928	113	194,607	16,851	171	174,301	15,093	81
Jul-35	184,075	15,907	113	194,788	16,833	172	174,390	15,070	81
Aug-35	184,191	15,910	113	194,952	16,840	172	174,464	15,070	80
Sep-35	184,398	15,909	113	195,213	16,842	172	174,624	15,066	80
Oct-35	184,786	15,907	113	195,666	16,844	172	174,956	15,061	80
Nov-35	185,321	15,927	112	196,274	16,868	173	175,426	15,077	80
Dec-35	185,711	16,002	112	196,730	16,951	173	175,759	15,144	79
Jan-36	185,960	16,015	112	197,036	16,969	173	175,959	15,154	79
Feb-36	185,925	16,027	112	197,041	16,985	173	175,889	15,162	79
Mar-36	185,933	16,029	112	197,092	16,991	174	175,861	15,161	79
Apr-36	185,860	16,000	112	197,057	16,964	174	175,755	15,130	78
May-36	185,782	15,983	112	197,017	16,950	174	175,646	15,111	78
Jun-36	185,601	15,984	112	196,867	16,954	174	175,439	15,109	78
Jul-36	185,728	15,963	112	197,042	16,935	175	175,524	15,086	78

	Washington - Expected Growth			Washington - High Growth			Washington - Low Growth		
	Residential Customers	Commercial Customers	Industrial Customers	Residential Customers	Commercial Customers	Industrial Customers	Residential Customers	Commercial Customers	Industrial Customers
Aug-36	185,840	15,966	112	197,201	16,942	175	175,596	15,086	77
Sep-36	186,044	15,965	112	197,458	16,944	175	175,754	15,082	77
Oct-36	186,428	15,963	112	197,907	16,946	175	176,083	15,077	77
Nov-36	186,959	15,983	111	198,510	16,971	176	176,549	15,093	77
Dec-36	187,347	16,058	111	198,963	17,054	176	176,881	15,161	76
Jan-37	187,591	16,070	111	199,263	17,070	176	177,077	15,169	76
Feb-37	187,552	16,083	111	199,262	17,087	176	177,005	15,179	76
Mar-37	187,557	16,086	111	199,309	17,094	177	176,976	15,178	76
Apr-37	187,480	16,056	111	199,267	17,065	177	176,868	15,147	75
May-37	187,399	16,038	111	199,222	17,050	177	176,757	15,127	75
Jun-37	187,213	16,039	111	199,065	17,054	177	176,548	15,125	75
Jul-37	187,338	16,018	111	199,237	17,035	178	176,632	15,103	75
Aug-37	187,446	16,021	111	199,391	17,042	178	176,702	15,103	74
Sep-37	187,647	16,020	111	199,643	17,044	178	176,858	15,099	74
Oct-37	188,028	16,019	111	200,087	17,046	178	177,184	15,095	74
Nov-37	188,555	16,038	111	200,688	17,070	179	177,648	15,110	74
Dec-37	188,939	16,113	110	201,135	17,153	179	177,976	15,178	73
Jan-38	189,180	16,125	110	201,432	17,169	179	178,170	15,187	73
Feb-38	189,138	16,138	110	201,426	17,186	179	178,097	15,196	73
Mar-38	189,140	16,140	110	201,467	17,192	180	178,066	15,195	73
Apr-38	189,059	16,110	110	201,420	17,163	180	177,957	15,164	72
May-38	188,974	16,093	110	201,369	17,149	180	177,843	15,145	72
Jun-38	188,785	16,094	110	201,207	17,153	180	177,633	15,143	72
Jul-38	188,907	16,073	110	201,374	17,134	181	177,715	15,121	72
Aug-38	189,014	16,075	110	201,526	17,139	181	177,784	15,120	71
Sep-38	189,210	16,075	110	201,773	17,142	181	177,937	15,117	71
Oct-38	189,589	16,073	110	202,215	17,143	181	178,261	15,113	71
Nov-38	190,113	16,092	110	202,813	17,167	182	178,722	15,128	71
Dec-38	190,495	16,166	110	203,258	17,249	182	179,049	15,195	70
Jan-39	190,733	16,179	109	203,550	17,266	182	179,241	15,204	70
Feb-39	190,689	16,191	109	203,541	17,282	182	179,167	15,213	70
Mar-39	190,688	16,194	109	203,578	17,289	183	179,134	15,213	70
Apr-39	190,604	16,164	109	203,527	17,260	183	179,023	15,182	69
May-39	190,517	16,146	109	203,472	17,244	183	178,909	15,162	69
Jun-39	190,325	16,147	109	203,306	17,248	183	178,697	15,160	69
Jul-39	190,446	16,127	109	203,472	17,230	184	178,779	15,139	69
Aug-39	190,551	16,129	109	203,621	17,235	184	178,846	15,138	68
Sep-39	190,746	16,129	109	203,867	17,238	184	178,999	15,136	68
Oct-39	191,124	16,126	109	204,308	17,238	184	179,322	15,130	68
Nov-39	191,646	16,145	109	204,904	17,262	185	179,780	15,145	68
Dec-39	192,027	16,220	109	205,348	17,345	185	180,106	15,213	67

	Washington - Expected Growth			Washington - High Growth			Washington - Low Growth		
	Residential Customers	Commercial Customers	Industrial Customers	Residential Customers	Commercial Customers	Industrial Customers	Residential Customers	Commercial Customers	Industrial Customers
Jan-40	192,264	16,232	108	205,639	17,361	185	180,296	15,222	67
Feb-40	192,217	16,244	108	205,627	17,377	185	180,221	15,230	67
Mar-40	192,215	16,247	108	205,662	17,384	186	180,188	15,230	67
Apr-40	192,130	16,217	108	205,609	17,355	186	180,077	15,200	66
May-40	192,041	16,199	108	205,551	17,339	186	179,962	15,180	66
Jun-40	191,849	16,200	108	205,383	17,343	186	179,750	15,178	66
Jul-40	191,981	16,180	108	205,569	17,325	187	179,838	15,157	66
Aug-40	192,099	16,183	108	205,738	17,332	187	179,911	15,156	65
Sep-40	192,307	16,182	108	206,006	17,335	187	180,070	15,152	65
Oct-40	192,698	16,180	108	206,468	17,336	187	180,399	15,147	65

APPENDIX 2.2: CUSTOMER FORECASTS BY REGION IDAHO

	Idaho - Expected Growth			Idaho - High Growth			Idaho - Low Growth		
	Residential Customers	Commercial Customers	Industrial Customers	Residential Customers	Commercial Customers	Industrial Customers	Residential Customers	Commercial Customers	Industrial Customers
Nov-19	77,428	9,129	87	77,428	9,129	87	77,428	9,129	87
Dec-19	77,804	9,164	89	77,804	9,164	89	77,804	9,164	89
Jan-20	78,014	9,229	89	78,014	9,229	89	78,014	9,229	89
Feb-20	78,071	9,153	89	78,071	9,153	89	78,071	9,153	89
Mar-20	78,174	9,211	89	78,174	9,211	89	78,174	9,211	89
Apr-20	78,258	9,199	89	78,258	9,199	89	78,258	9,199	89
May-20	78,205	9,063	87	78,205	9,063	87	78,205	9,063	87
Jun-20	78,176	9,078	89	78,887	9,160	87	77,472	8,996	87
Jul-20	78,330	9,074	89	79,071	9,160	87	77,597	8,989	87
Aug-20	78,346	9,192	89	79,116	9,282	88	77,584	9,103	87
Sep-20	78,485	9,174	89	79,285	9,268	88	77,693	9,081	86
Oct-20	78,647	9,200	89	79,477	9,297	88	77,824	9,104	86
Nov-20	78,845	9,184	88	79,707	9,284	88	77,992	9,085	86
Dec-20	79,147	9,215	89	80,041	9,319	88	78,262	9,112	86
Jan-21	79,275	9,233	88	80,200	9,341	88	78,360	9,126	86
Feb-21	79,226	9,203	88	80,180	9,314	89	78,283	9,093	86
Mar-21	79,185	9,189	88	80,168	9,303	89	78,214	9,076	85
Apr-21	79,153	9,201	88	80,165	9,319	89	78,154	9,085	85
May-21	79,088	9,192	88	80,128	9,313	89	78,061	9,073	85
Jun-21	79,035	9,196	88	80,104	9,320	89	77,980	9,073	85
Jul-21	79,155	9,191	88	80,271	9,321	89	78,053	9,063	85
Aug-21	79,243	9,190	88	80,407	9,325	90	78,095	9,057	84
Sep-21	79,426	9,170	88	80,639	9,310	90	78,230	9,032	84
Oct-21	79,622	9,198	88	80,885	9,344	90	78,378	9,054	84
Nov-21	79,864	9,201	87	81,177	9,352	90	78,571	9,052	84
Dec-21	80,172	9,212	88	81,537	9,369	90	78,829	9,058	84
Jan-22	80,330	9,254	87	81,745	9,417	90	78,939	9,094	84
Feb-22	80,331	9,216	88	81,793	9,384	91	78,894	9,051	83
Mar-22	80,340	9,207	87	81,849	9,380	91	78,858	9,037	83
Apr-22	80,325	9,244	87	81,881	9,423	91	78,798	9,068	83
May-22	80,302	9,239	87	81,905	9,423	91	78,730	9,058	83
Jun-22	80,294	9,226	87	81,944	9,416	91	78,677	9,040	83
Jul-22	80,429	9,239	87	82,137	9,435	91	78,756	9,047	83
Aug-22	80,543	9,226	87	82,309	9,428	92	78,815	9,028	82
Sep-22	80,733	9,202	87	82,558	9,410	92	78,947	8,999	82
Oct-22	80,947	9,265	87	82,833	9,481	92	79,103	9,054	82
Nov-22	81,213	9,245	87	83,161	9,467	92	79,310	9,028	82
Dec-22	81,542	9,269	87	83,554	9,498	92	79,578	9,046	82
Jan-23	81,715	9,325	86	83,788	9,562	92	79,693	9,094	82
Feb-23	81,733	9,271	87	83,863	9,513	93	79,657	9,036	81

	Idaho - Expected Growth			Idaho - High Growth			Idaho - Low Growth		
	Residential Customers	Commercial Customers	Industrial Customers	Residential Customers	Commercial Customers	Industrial Customers	Residential Customers	Commercial Customers	Industrial Customers
Mar-23	81,765	9,278	86	83,952	9,526	93	79,634	9,036	81
Apr-23	81,768	9,316	86	84,012	9,572	93	79,584	9,067	81
May-23	81,767	9,317	86	84,067	9,579	93	79,529	9,062	81
Jun-23	81,774	9,295	86	84,131	9,563	93	79,482	9,035	81
Jul-23	81,908	9,318	86	84,324	9,593	93	79,560	9,051	81
Aug-23	82,024	9,310	86	84,499	9,591	94	79,621	9,037	80
Sep-23	82,213	9,289	86	84,750	9,576	94	79,752	9,011	80
Oct-23	82,426	9,355	86	85,025	9,650	94	79,906	9,069	80
Nov-23	82,690	9,332	86	85,353	9,633	94	80,109	9,041	80
Dec-23	83,020	9,362	86	85,750	9,670	94	80,376	9,064	80
Jan-24	83,192	9,403	86	85,984	9,719	94	80,489	9,098	80
Feb-24	83,210	9,359	86	86,060	9,680	95	80,454	9,049	79
Mar-24	83,241	9,369	86	86,148	9,696	95	80,431	9,053	79
Apr-24	83,242	9,387	86	86,206	9,721	95	80,379	9,064	79
May-24	83,242	9,384	85	86,263	9,725	95	80,326	9,055	79
Jun-24	83,248	9,385	85	86,326	9,732	95	80,279	9,050	79
Jul-24	83,378	9,390	85	86,514	9,743	95	80,355	9,050	79
Aug-24	83,490	9,388	85	86,685	9,747	96	80,412	9,042	78
Sep-24	83,676	9,370	85	86,932	9,735	96	80,541	9,019	78
Oct-24	83,885	9,411	85	87,203	9,783	96	80,692	9,053	78
Nov-24	84,145	9,402	85	87,528	9,780	96	80,892	9,039	78
Dec-24	84,470	9,427	85	87,921	9,812	96	81,154	9,057	78
Jan-25	84,638	9,464	85	88,151	9,857	96	81,264	9,087	78
Feb-25	84,653	9,427	85	88,222	9,824	97	81,228	9,046	77
Mar-25	84,680	9,425	85	88,305	9,828	97	81,203	9,038	77
Apr-25	84,677	9,452	85	88,357	9,863	97	81,150	9,058	77
May-25	84,673	9,449	85	88,408	9,866	97	81,095	9,050	77
Jun-25	84,675	9,445	85	88,465	9,868	97	81,047	9,040	77
Jul-25	84,782	9,449	85	88,620	9,877	97	81,109	9,040	77
Aug-25	84,871	9,439	84	88,756	9,871	98	81,155	9,026	76
Sep-25	85,034	9,416	84	88,970	9,852	98	81,271	8,999	76
Oct-25	85,219	9,461	84	89,207	9,904	98	81,408	9,038	76
Nov-25	85,456	9,448	84	89,499	9,895	98	81,595	9,021	76
Dec-25	85,758	9,466	84	89,859	9,919	98	81,843	9,034	76
Jan-26	85,903	9,510	84	90,055	9,970	98	81,942	9,072	76
Feb-26	85,894	9,463	84	90,089	9,925	99	81,893	9,022	75
Mar-26	85,897	9,459	84	90,136	9,926	99	81,856	9,014	75
Apr-26	85,871	9,490	84	90,153	9,963	99	81,792	9,039	75
May-26	85,843	9,485	84	90,168	9,963	99	81,725	9,030	75
Jun-26	85,822	9,470	84	90,189	9,952	99	81,665	9,011	75

	Idaho - Expected Growth			Idaho - High Growth			Idaho - Low Growth		
	Residential Customers	Commercial Customers	Industrial Customers	Residential Customers	Commercial Customers	Industrial Customers	Residential Customers	Commercial Customers	Industrial Customers
Jul-26	85,927	9,481	84	90,343	9,968	99	81,726	9,018	75
Aug-26	86,014	9,469	84	90,477	9,960	100	81,770	9,002	74
Sep-26	86,176	9,444	84	90,690	9,939	100	81,886	8,974	74
Oct-26	86,360	9,499	84	90,927	10,001	100	82,022	9,022	74
Nov-26	86,595	9,478	83	91,217	9,984	100	82,206	8,998	74
Dec-26	86,896	9,500	83	91,578	10,012	100	82,453	9,014	74
Jan-27	87,039	9,543	83	91,772	10,062	100	82,549	9,051	74
Feb-27	87,029	9,493	83	91,805	10,014	101	82,501	8,999	73
Mar-27	87,031	9,495	83	91,851	10,021	101	82,464	8,997	73
Apr-27	87,003	9,520	83	91,865	10,052	101	82,398	9,016	73
May-27	86,974	9,515	83	91,877	10,051	101	82,332	9,007	73
Jun-27	86,951	9,502	83	91,897	10,043	101	82,271	8,991	73
Jul-27	87,057	9,512	83	92,052	10,058	101	82,332	8,996	73
Aug-27	87,144	9,503	83	92,187	10,053	102	82,376	8,983	72
Sep-27	87,306	9,480	83	92,402	10,033	102	82,491	8,957	72
Oct-27	87,490	9,530	83	92,640	10,091	102	82,626	9,000	72
Nov-27	87,726	9,510	83	92,933	10,075	102	82,810	8,977	72
Dec-27	88,028	9,534	83	93,297	10,105	102	83,056	8,996	72
Jan-28	88,171	9,572	83	93,492	10,150	102	83,152	9,027	72
Feb-28	88,161	9,526	82	93,525	10,106	103	83,103	8,980	71
Mar-28	88,163	9,527	82	93,571	10,111	103	83,066	8,976	71
Apr-28	88,136	9,549	82	93,587	10,140	103	83,002	8,993	71
May-28	88,106	9,543	82	93,599	10,138	103	82,935	8,983	71
Jun-28	88,084	9,534	82	93,619	10,133	103	82,875	8,970	71
Jul-28	88,190	9,539	82	93,775	10,143	103	82,936	8,971	71
Aug-28	88,279	9,531	82	93,914	10,139	104	82,982	8,959	70
Sep-28	88,441	9,508	82	94,130	10,120	104	83,095	8,933	70
Oct-28	88,626	9,553	82	94,371	10,172	104	83,230	8,971	70
Nov-28	88,862	9,538	82	94,666	10,161	104	83,413	8,953	70
Dec-28	89,164	9,559	82	95,032	10,188	104	83,658	8,969	70
Jan-29	89,308	9,597	82	95,230	10,233	104	83,754	9,000	70
Feb-29	89,298	9,552	82	95,263	10,190	105	83,706	8,954	69
Mar-29	89,301	9,550	82	95,311	10,193	105	83,669	8,948	69
Apr-29	89,274	9,576	82	95,326	10,225	105	83,605	8,968	69
May-29	89,245	9,570	81	95,340	10,224	105	83,539	8,958	69
Jun-29	89,223	9,559	81	95,360	10,217	105	83,480	8,944	69
Jul-29	89,329	9,566	81	95,517	10,229	105	83,541	8,946	69
Aug-29	89,417	9,555	81	95,655	10,222	106	83,585	8,932	68
Sep-29	89,579	9,531	81	95,872	10,201	106	83,698	8,905	68
Oct-29	89,763	9,580	81	96,113	10,258	106	83,832	8,947	68

	Idaho - Expected Growth			Idaho - High Growth			Idaho - Low Growth		
	Residential Customers	Commercial Customers	Industrial Customers	Residential Customers	Commercial Customers	Industrial Customers	Residential Customers	Commercial Customers	Industrial Customers
Nov-29	89,999	9,562	81	96,410	10,243	106	84,014	8,926	68
Dec-29	90,301	9,583	81	96,778	10,270	106	84,257	8,942	68
Jan-30	90,444	9,624	81	96,975	10,319	106	84,352	8,976	68
Feb-30	90,434	9,576	81	97,009	10,272	107	84,304	8,927	67
Mar-30	90,437	9,575	81	97,056	10,276	107	84,268	8,922	67
Apr-30	90,409	9,601	81	97,071	10,308	107	84,204	8,942	67
May-30	90,380	9,596	81	97,084	10,308	107	84,138	8,933	67
Jun-30	90,358	9,583	81	97,105	10,299	107	84,079	8,917	67
Jul-30	90,466	9,592	81	97,266	10,313	107	84,141	8,921	67
Aug-30	90,557	9,582	80	97,409	10,307	108	84,186	8,908	66
Sep-30	90,721	9,557	80	97,631	10,285	108	84,300	8,881	66
Oct-30	90,908	9,608	80	97,877	10,345	108	84,434	8,924	66
Nov-30	91,147	9,589	80	98,180	10,329	108	84,617	8,902	66
Dec-30	91,451	9,611	80	98,553	10,357	108	84,860	8,918	66
Jan-31	91,597	9,651	80	98,757	10,405	108	84,956	8,951	66
Feb-31	91,590	9,604	80	98,795	10,360	109	84,910	8,904	65
Mar-31	91,594	9,604	80	98,845	10,364	109	84,874	8,899	65
Apr-31	91,570	9,628	80	98,865	10,395	109	84,812	8,918	65
May-31	91,543	9,623	80	98,882	10,395	109	84,748	8,909	65
Jun-31	91,524	9,612	80	98,907	10,387	109	84,691	8,894	65
Jul-31	91,634	9,619	80	99,072	10,400	109	84,753	8,897	65
Aug-31	91,726	9,610	80	99,218	10,395	110	84,799	8,884	64
Sep-31	91,892	9,587	80	99,444	10,375	110	84,913	8,859	64
Oct-31	92,081	9,636	80	99,695	10,433	110	85,048	8,900	64
Nov-31	92,321	9,617	79	100,002	10,417	110	85,230	8,878	64
Dec-31	92,627	9,639	79	100,380	10,446	110	85,472	8,894	64
Jan-32	92,775	9,678	79	100,587	10,493	110	85,569	8,926	64
Feb-32	92,769	9,633	79	100,628	10,449	111	85,523	8,881	63
Mar-32	92,776	9,632	79	100,682	10,453	111	85,490	8,876	63
Apr-32	92,753	9,657	79	100,704	10,485	111	85,429	8,894	63
May-32	92,728	9,650	79	100,724	10,482	111	85,366	8,884	63
Jun-32	92,710	9,640	79	100,752	10,476	111	85,309	8,871	63
Jul-32	92,822	9,647	79	100,920	10,489	111	85,373	8,873	63
Aug-32	92,915	9,638	79	101,069	10,484	112	85,418	8,860	62
Sep-32	93,083	9,614	79	101,299	10,463	112	85,533	8,834	62
Oct-32	93,273	9,662	79	101,553	10,520	112	85,667	8,874	62
Nov-32	93,515	9,645	79	101,864	10,506	112	85,849	8,854	62
Dec-32	93,822	9,666	79	102,246	10,534	112	86,091	8,870	62
Jan-33	93,971	9,706	79	102,457	10,583	112	86,187	8,902	62
Feb-33	93,967	9,660	79	102,500	10,537	113	86,143	8,856	61

	Idaho - Expected Growth			Idaho - High Growth			Idaho - Low Growth		
	Residential Customers	Commercial Customers	Industrial Customers	Residential Customers	Commercial Customers	Industrial Customers	Residential Customers	Commercial Customers	Industrial Customers
Mar-33	93,975	9,659	78	102,557	10,541	113	86,111	8,851	61
Apr-33	93,954	9,685	78	102,582	10,574	113	86,051	8,870	61
May-33	93,930	9,679	78	102,604	10,573	113	85,989	8,861	61
Jun-33	93,914	9,668	78	102,634	10,566	113	85,934	8,847	61
Jul-33	94,027	9,675	78	102,806	10,578	113	85,997	8,849	61
Aug-33	94,122	9,665	78	102,958	10,572	114	86,043	8,835	60
Sep-33	94,292	9,642	78	103,193	10,552	114	86,158	8,810	60
Oct-33	94,483	9,691	78	103,450	10,611	114	86,292	8,851	60
Nov-33	94,727	9,673	78	103,766	10,596	114	86,475	8,830	60
Dec-33	95,036	9,695	78	104,154	10,625	114	86,716	8,846	60
Jan-34	95,187	9,736	78	104,368	10,675	114	86,813	8,880	60
Feb-34	95,185	9,688	78	104,415	10,627	115	86,770	8,832	59
Mar-34	95,194	9,688	78	104,474	10,632	115	86,738	8,827	59
Apr-34	95,175	9,713	78	104,502	10,665	115	86,680	8,846	59
May-34	95,153	9,708	78	104,527	10,664	115	86,619	8,837	59
Jun-34	95,139	9,697	77	104,561	10,657	115	86,565	8,823	59
Jul-34	95,253	9,705	77	104,735	10,671	115	86,628	8,826	59
Aug-34	95,350	9,695	77	104,891	10,665	116	86,676	8,813	58
Sep-34	95,520	9,671	77	105,128	10,644	116	86,790	8,787	58
Oct-34	95,713	9,721	77	105,390	10,704	116	86,924	8,828	58
Nov-34	95,958	9,703	77	105,709	10,689	116	87,106	8,808	58
Dec-34	96,268	9,725	77	106,100	10,718	116	87,346	8,824	58
Jan-35	96,421	9,765	77	106,319	10,767	116	87,444	8,856	58
Feb-35	96,420	9,719	77	106,368	10,722	117	87,402	8,810	57
Mar-35	96,431	9,718	77	106,430	10,726	117	87,371	8,805	57
Apr-35	96,412	9,743	77	106,459	10,758	117	87,313	8,823	57
May-35	96,392	9,737	77	106,487	10,757	117	87,253	8,814	57
Jun-35	96,379	9,727	77	106,522	10,751	117	87,201	8,801	57
Jul-35	96,495	9,734	77	106,701	10,764	117	87,265	8,803	57
Aug-35	96,593	9,725	77	106,860	10,759	118	87,312	8,791	56
Sep-35	96,765	9,702	76	107,100	10,738	118	87,426	8,766	56
Oct-35	96,960	9,750	76	107,367	10,797	118	87,561	8,805	56
Nov-35	97,207	9,733	76	107,691	10,783	118	87,743	8,785	56
Dec-35	97,519	9,755	76	108,088	10,812	118	87,983	8,801	56
Jan-36	97,673	9,795	76	108,309	10,862	118	88,080	8,833	56
Feb-36	97,673	9,749	76	108,361	10,816	119	88,039	8,787	55
Mar-36	97,686	9,748	76	108,426	10,820	119	88,009	8,782	55
Apr-36	97,670	9,773	76	108,459	10,853	119	87,953	8,801	55
May-36	97,651	9,767	76	108,490	10,851	119	87,895	8,791	55
Jun-36	97,639	9,756	76	108,527	10,844	119	87,842	8,777	55
Jul-36	97,756	9,764	76	108,709	10,858	119	87,906	8,780	55

	Idaho - Expected Growth			Idaho - High Growth			Idaho - Low Growth		
	Residential Customers	Commercial Customers	Industrial Customers	Residential Customers	Commercial Customers	Industrial Customers	Residential Customers	Commercial Customers	Industrial Customers
Aug-36	97,856	9,755	76	108,871	10,853	120	87,955	8,768	54
Sep-36	98,029	9,732	76	109,115	10,833	120	88,069	8,743	54
Oct-36	98,225	9,781	76	109,384	10,892	120	88,203	8,783	54
Nov-36	98,473	9,762	76	109,712	10,876	120	88,384	8,762	54
Dec-36	98,786	9,784	75	110,113	10,906	120	88,624	8,778	54
Jan-37	98,941	9,824	75	110,337	10,956	120	88,721	8,809	54
Feb-37	98,943	9,778	75	110,392	10,909	121	88,681	8,764	53
Mar-37	98,957	9,778	75	110,459	10,915	121	88,652	8,760	53
Apr-37	98,942	9,803	75	110,495	10,948	121	88,597	8,778	53
May-37	98,924	9,798	75	110,526	10,947	121	88,539	8,769	53
Jun-37	98,914	9,786	75	110,567	10,939	121	88,488	8,755	53
Jul-37	99,032	9,794	75	110,751	10,953	121	88,552	8,758	53
Aug-37	99,132	9,785	75	110,915	10,948	122	88,600	8,745	52
Sep-37	99,306	9,761	75	111,161	10,926	122	88,714	8,720	52
Oct-37	99,503	9,811	75	111,434	10,987	122	88,849	8,761	52
Nov-37	99,751	9,793	75	111,764	10,972	122	89,029	8,740	52
Dec-37	100,065	9,815	75	112,168	11,002	122	89,267	8,756	52
Jan-38	100,221	9,854	75	112,395	11,051	122	89,365	8,787	52
Feb-38	100,223	9,808	75	112,450	11,005	123	89,325	8,741	51
Mar-38	100,238	9,807	74	112,520	11,009	123	89,296	8,737	51
Apr-38	100,223	9,833	74	112,555	11,043	123	89,241	8,756	51
May-38	100,206	9,828	74	112,589	11,043	123	89,184	8,747	51
Jun-38	100,197	9,817	74	112,632	11,035	123	89,135	8,733	51
Jul-38	100,316	9,825	74	112,818	11,049	123	89,199	8,736	51
Aug-38	100,417	9,814	74	112,984	11,042	124	89,247	8,722	50
Sep-38	100,593	9,791	74	113,235	11,022	124	89,361	8,698	50
Oct-38	100,791	9,840	74	113,511	11,082	124	89,495	8,737	50
Nov-38	101,041	9,823	74	113,846	11,068	124	89,675	8,718	50
Dec-38	101,356	9,845	74	114,254	11,098	124	89,913	8,734	50
Jan-39	101,513	9,885	74	114,485	11,148	124	90,010	8,765	50
Feb-39	101,517	9,838	74	114,543	11,100	125	89,972	8,719	49
Mar-39	101,533	9,837	74	114,615	11,104	125	89,944	8,714	49
Apr-39	101,519	9,862	74	114,652	11,138	125	89,889	8,732	49
May-39	101,504	9,857	74	114,689	11,137	125	89,834	8,724	49
Jun-39	101,496	9,846	73	114,734	11,130	125	89,785	8,710	49
Jul-39	101,614	9,854	73	114,920	11,144	125	89,848	8,713	49
Aug-39	101,716	9,845	73	115,088	11,139	126	89,897	8,701	48
Sep-39	101,891	9,820	73	115,339	11,116	126	90,010	8,675	48
Oct-39	102,088	9,869	73	115,615	11,177	126	90,143	8,714	48
Nov-39	102,338	9,851	73	115,952	11,161	126	90,322	8,694	48
Dec-39	102,652	9,873	73	116,361	11,192	126	90,558	8,710	48

	Idaho - Expected Growth			Idaho - High Growth			Idaho - Low Growth		
	Residential Customers	Commercial Customers	Industrial Customers	Residential Customers	Commercial Customers	Industrial Customers	Residential Customers	Commercial Customers	Industrial Customers
Jan-40	102,809	9,913	73	116,592	11,242	126	90,654	8,741	48
Feb-40	102,813	9,867	73	116,650	11,195	127	90,616	8,697	47
Mar-40	102,828	9,866	73	116,721	11,199	127	90,588	8,692	47
Apr-40	102,814	9,890	73	116,759	11,231	127	90,534	8,709	47
May-40	102,798	9,885	73	116,794	11,231	127	90,478	8,700	47
Jun-40	102,790	9,874	73	116,839	11,224	127	90,430	8,687	47
Jul-40	102,910	9,882	73	117,029	11,238	127	90,494	8,690	47
Aug-40	103,012	9,872	73	117,199	11,232	128	90,542	8,677	46
Sep-40	103,188	9,849	72	117,453	11,211	128	90,655	8,653	46
Oct-40	103,387	9,898	72	117,733	11,272	128	90,788	8,692	46

APPENDIX 2.2: CUSTOMER FORECASTS BY REGION MEDFORD

	Medford - Expected Growth			Medford - High Growth			Medford - Low Growth		
	Residential Customers	Commercial Customers	Industrial Customers	Residential Customers	Commercial Customers	Industrial Customers	Residential Customers	Commercial Customers	Industrial Customers
Nov-19	56,068	6,975	14	56,068	6,975	14	56,068	6,975	14
Dec-19	56,354	7,038	14	56,354	7,038	14	56,354	7,038	14
Jan-20	56,493	7,088	14	56,493	7,088	14	56,493	7,088	14
Feb-20	56,432	7,074	14	56,432	7,074	14	56,432	7,074	14
Mar-20	56,507	7,073	14	56,507	7,073	14	56,507	7,073	14
Apr-20	56,516	7,053	14	56,516	7,053	14	56,516	7,053	14
May-20	56,377	6,941	14	56,377	6,941	14	56,377	6,941	14
Jun-20	56,298	6,909	14	56,396	6,921	14	56,188	6,895	14
Jul-20	56,152	6,896	14	56,259	6,909	14	56,032	6,881	14
Aug-20	56,070	7,012	14	56,186	7,026	14	55,940	6,995	14
Sep-20	56,037	6,994	14	56,162	7,009	14	55,897	6,976	14
Oct-20	56,266	7,007	14	56,401	7,023	14	56,115	6,988	14
Nov-20	56,600	7,042	14	56,745	7,060	14	56,438	7,021	14
Dec-20	56,918	7,090	14	57,073	7,109	14	56,744	7,068	14
Jan-21	57,105	7,107	14	57,270	7,128	14	56,920	7,084	14
Feb-21	57,090	7,120	14	57,264	7,142	14	56,895	7,096	14
Mar-21	57,106	7,122	14	57,290	7,145	14	56,900	7,097	14
Apr-21	57,063	7,103	14	57,256	7,127	14	56,847	7,076	14
May-21	56,973	7,095	14	57,175	7,121	15	56,747	7,067	14
Jun-21	56,842	7,082	14	57,053	7,109	15	56,606	7,053	13
Jul-21	56,718	7,062	14	56,941	7,090	15	56,468	7,031	13
Aug-21	56,661	7,055	14	56,897	7,085	15	56,396	7,022	13
Sep-21	56,654	7,046	14	56,903	7,077	15	56,375	7,012	13
Oct-21	56,928	7,063	14	57,191	7,096	15	56,633	7,027	13
Nov-21	57,289	7,100	14	57,567	7,135	15	56,978	7,062	13
Dec-21	57,631	7,145	14	57,924	7,182	15	57,303	7,105	13
Jan-22	57,847	7,185	14	58,155	7,223	15	57,503	7,142	13
Feb-22	57,847	7,194	14	58,168	7,234	15	57,488	7,149	13
Mar-22	57,880	7,196	14	58,214	7,238	15	57,506	7,150	13
Apr-22	57,854	7,181	14	58,202	7,224	15	57,465	7,133	13
May-22	57,780	7,174	14	58,140	7,219	15	57,377	7,124	13
Jun-22	57,671	7,163	14	58,044	7,209	15	57,254	7,111	13
Jul-22	57,527	7,140	14	57,909	7,187	15	57,101	7,087	13
Aug-22	57,452	7,134	14	57,843	7,183	15	57,015	7,080	13
Sep-22	57,429	7,122	14	57,829	7,172	15	56,982	7,067	13
Oct-22	57,685	7,138	14	58,097	7,189	15	57,225	7,081	13
Nov-22	58,029	7,174	14	58,453	7,226	15	57,556	7,115	13
Dec-22	58,351	7,218	14	58,787	7,272	15	57,864	7,158	13
Jan-23	58,547	7,256	14	58,995	7,312	15	58,047	7,194	13
Feb-23	58,527	7,264	14	58,984	7,321	15	58,017	7,201	13

	Medford - Expected Growth			Medford - High Growth			Medford - Low Growth		
	Residential	Commercial	Industrial	Residential	Commercial	Industrial	Residential	Commercial	Industrial
	Customers	Customers	Customers	Customers	Customers	Customers	Customers	Customers	Customers
Mar-23	58,540	7,265	14	59,007	7,323	15	58,019	7,201	13
Apr-23	58,493	7,247	14	58,970	7,306	15	57,961	7,181	13
May-23	58,400	7,239	14	58,886	7,300	16	57,858	7,172	13
Jun-23	58,270	7,227	14	58,765	7,289	16	57,719	7,159	12
Jul-23	58,132	7,204	14	58,636	7,267	16	57,570	7,135	12
Aug-23	58,061	7,198	14	58,575	7,262	16	57,488	7,127	12
Sep-23	58,043	7,187	14	58,567	7,252	16	57,459	7,115	12
Oct-23	58,304	7,203	14	58,841	7,270	16	57,706	7,129	12
Nov-23	58,651	7,239	14	59,202	7,307	16	58,038	7,164	12
Dec-23	58,978	7,283	14	59,542	7,353	16	58,349	7,206	12
Jan-24	59,178	7,321	14	59,755	7,393	16	58,536	7,242	12
Feb-24	59,162	7,329	14	59,749	7,402	16	58,508	7,248	12
Mar-24	59,179	7,331	14	59,777	7,406	16	58,513	7,249	12
Apr-24	59,137	7,313	14	59,746	7,389	16	58,460	7,230	12
May-24	59,047	7,306	14	59,665	7,383	16	58,359	7,221	12
Jun-24	58,922	7,293	14	59,550	7,371	16	58,224	7,207	12
Jul-24	58,791	7,271	14	59,429	7,350	16	58,081	7,184	12
Aug-24	58,729	7,266	14	59,378	7,347	16	58,007	7,177	12
Sep-24	58,718	7,255	14	59,379	7,337	16	57,983	7,165	12
Oct-24	58,987	7,272	14	59,663	7,356	16	58,235	7,180	12
Nov-24	59,342	7,309	14	60,034	7,395	16	58,573	7,215	12
Dec-24	59,677	7,353	14	60,385	7,441	16	58,890	7,256	12
Jan-25	59,885	7,391	14	60,608	7,480	16	59,082	7,292	12
Feb-25	59,877	7,400	14	60,612	7,491	16	59,061	7,299	12
Mar-25	59,902	7,402	14	60,649	7,494	16	59,072	7,299	12
Apr-25	59,867	7,385	14	60,626	7,479	16	59,024	7,281	12
May-25	59,786	7,378	14	60,556	7,473	17	58,931	7,272	12
Jun-25	59,669	7,366	14	60,450	7,462	17	58,803	7,259	11
Jul-25	59,531	7,344	14	60,321	7,441	17	58,655	7,236	11
Aug-25	59,462	7,338	14	60,262	7,437	17	58,575	7,229	11
Sep-25	59,444	7,327	14	60,254	7,427	17	58,546	7,216	11
Oct-25	59,706	7,343	14	60,531	7,444	17	58,792	7,231	11
Nov-25	60,055	7,380	14	60,895	7,483	17	59,124	7,266	11
Dec-25	60,383	7,424	14	61,239	7,529	17	59,435	7,307	11
Jan-26	60,584	7,460	14	61,454	7,567	17	59,620	7,341	11
Feb-26	60,569	7,468	14	61,449	7,576	17	59,594	7,348	11
Mar-26	60,587	7,470	14	61,479	7,580	17	59,599	7,348	11
Apr-26	60,546	7,453	14	61,448	7,564	17	59,547	7,330	11
May-26	60,458	7,445	14	61,370	7,557	17	59,449	7,321	11
Jun-26	60,334	7,433	14	61,255	7,546	17	59,315	7,307	11

	Medford - Expected Growth			Medford - High Growth			Medford - Low Growth		
	Residential Customers	Commercial Customers	Industrial Customers	Residential Customers	Commercial Customers	Industrial Customers	Residential Customers	Commercial Customers	Industrial Customers
Jul-26	60,195	7,410	14	61,124	7,524	17	59,167	7,283	11
Aug-26	60,125	7,404	14	61,064	7,519	17	59,086	7,276	11
Sep-26	60,106	7,393	14	61,055	7,510	17	59,056	7,264	11
Oct-26	60,368	7,409	14	61,332	7,527	17	59,302	7,278	11
Nov-26	60,715	7,446	14	61,695	7,566	17	59,631	7,313	11
Dec-26	61,042	7,490	14	62,038	7,612	17	59,940	7,355	11
Jan-27	61,242	7,525	14	62,252	7,649	17	60,125	7,388	11
Feb-27	61,226	7,533	14	62,247	7,659	17	60,098	7,394	11
Mar-27	61,243	7,535	14	62,275	7,662	17	60,102	7,395	11
Apr-27	61,201	7,518	14	62,243	7,646	17	60,050	7,377	11
May-27	61,112	7,510	14	62,163	7,639	18	59,950	7,367	11
Jun-27	60,987	7,498	14	62,047	7,629	18	59,816	7,354	10
Jul-27	60,847	7,475	14	61,915	7,606	18	59,668	7,330	10
Aug-27	60,775	7,469	14	61,852	7,602	18	59,586	7,323	10
Sep-27	60,755	7,458	14	61,842	7,592	18	59,555	7,311	10
Oct-27	61,014	7,474	14	62,116	7,609	18	59,797	7,325	10
Nov-27	61,360	7,510	14	62,479	7,647	18	60,125	7,359	10
Dec-27	61,686	7,554	14	62,821	7,693	18	60,433	7,401	10
Jan-28	61,884	7,589	14	63,034	7,730	18	60,616	7,434	10
Feb-28	61,866	7,597	14	63,026	7,740	18	60,587	7,440	10
Mar-28	61,882	7,599	14	63,053	7,743	18	60,591	7,441	10
Apr-28	61,838	7,581	14	63,018	7,726	18	60,536	7,422	10
May-28	61,747	7,573	14	62,936	7,719	18	60,436	7,413	10
Jun-28	61,620	7,561	14	62,817	7,708	18	60,300	7,399	10
Jul-28	61,478	7,538	14	62,683	7,686	18	60,150	7,376	10
Aug-28	61,404	7,532	14	62,617	7,681	18	60,067	7,368	10
Sep-28	61,382	7,520	14	62,605	7,670	18	60,035	7,355	10
Oct-28	61,639	7,536	14	62,877	7,688	18	60,275	7,370	10
Nov-28	61,983	7,572	14	63,238	7,726	18	60,601	7,403	10
Dec-28	62,306	7,616	14	63,578	7,772	18	60,906	7,445	10
Jan-29	62,503	7,651	14	63,789	7,809	18	61,087	7,478	10
Feb-29	62,483	7,659	14	63,779	7,818	18	61,057	7,484	10
Mar-29	62,496	7,661	14	63,802	7,821	18	61,058	7,485	10
Apr-29	62,450	7,643	14	63,766	7,804	18	61,002	7,466	10
May-29	62,357	7,635	14	63,681	7,797	19	60,901	7,457	10
Jun-29	62,228	7,622	14	63,559	7,785	19	60,764	7,443	9
Jul-29	62,084	7,599	14	63,422	7,763	19	60,613	7,419	9
Aug-29	62,009	7,593	14	63,355	7,758	19	60,529	7,412	9
Sep-29	61,985	7,582	14	63,340	7,748	19	60,495	7,400	9
Oct-29	62,241	7,597	14	63,612	7,765	19	60,734	7,413	9

	Medford - Expected Growth			Medford - High Growth			Medford - Low Growth		
	Residential Customers	Commercial Customers	Industrial Customers	Residential Customers	Commercial Customers	Industrial Customers	Residential Customers	Commercial Customers	Industrial Customers
Nov-29	62,583	7,633	14	63,971	7,803	19	61,057	7,447	9
Dec-29	62,904	7,677	14	64,309	7,849	19	61,360	7,489	9
Jan-30	63,099	7,712	14	64,518	7,886	19	61,539	7,522	9
Feb-30	63,078	7,720	14	64,507	7,895	19	61,508	7,528	9
Mar-30	63,089	7,721	14	64,528	7,897	19	61,508	7,528	9
Apr-30	63,041	7,703	14	64,489	7,880	19	61,451	7,509	9
May-30	62,947	7,695	14	64,403	7,873	19	61,349	7,500	9
Jun-30	62,816	7,682	14	64,279	7,861	19	61,210	7,486	9
Jul-30	62,670	7,659	14	64,139	7,839	19	61,058	7,462	9
Aug-30	62,592	7,653	14	64,068	7,834	19	60,972	7,455	9
Sep-30	62,565	7,641	14	64,050	7,822	19	60,936	7,442	9
Oct-30	62,818	7,656	14	64,318	7,839	19	61,172	7,456	9
Nov-30	63,158	7,692	14	64,676	7,877	19	61,493	7,489	9
Dec-30	63,477	7,736	14	65,012	7,923	19	61,794	7,531	9
Jan-31	63,669	7,771	14	65,218	7,960	19	61,970	7,564	9
Feb-31	63,645	7,778	14	65,203	7,968	19	61,937	7,569	9
Mar-31	63,654	7,779	14	65,222	7,971	19	61,935	7,569	9
Apr-31	63,604	7,761	14	65,180	7,953	19	61,877	7,550	9
May-31	63,507	7,753	14	65,090	7,946	20	61,772	7,541	9
Jun-31	63,374	7,740	14	64,963	7,934	20	61,633	7,527	8
Jul-31	63,225	7,717	14	64,819	7,912	20	61,478	7,504	8
Aug-31	63,145	7,710	14	64,746	7,906	20	61,391	7,496	8
Sep-31	63,116	7,698	14	64,725	7,894	20	61,353	7,483	8
Oct-31	63,367	7,713	14	64,992	7,911	20	61,588	7,497	8
Nov-31	63,704	7,749	14	65,347	7,949	20	61,905	7,530	8
Dec-31	64,021	7,793	14	65,681	7,995	20	62,204	7,572	8
Jan-32	64,211	7,827	14	65,885	8,031	20	62,379	7,604	8
Feb-32	64,185	7,835	14	65,867	8,041	20	62,344	7,611	8
Mar-32	64,191	7,835	14	65,883	8,042	20	62,340	7,609	8
Apr-32	64,139	7,817	14	65,838	8,024	20	62,280	7,591	8
May-32	64,040	7,809	14	65,746	8,017	20	62,174	7,582	8
Jun-32	63,904	7,796	14	65,615	8,005	20	62,032	7,568	8
Jul-32	63,753	7,772	14	65,469	7,982	20	61,876	7,544	8
Aug-32	63,671	7,766	14	65,393	7,976	20	61,788	7,537	8
Sep-32	63,641	7,754	14	65,371	7,965	20	61,749	7,524	8
Oct-32	63,890	7,769	14	65,636	7,982	20	61,982	7,537	8
Nov-32	64,225	7,804	14	65,988	8,019	20	62,297	7,570	8
Dec-32	64,540	7,848	14	66,321	8,065	20	62,594	7,612	8
Jan-33	64,728	7,883	14	66,523	8,101	20	62,767	7,644	8
Feb-33	64,700	7,890	14	66,503	8,110	20	62,730	7,650	8

	Medford - Expected Growth			Medford - High Growth			Medford - Low Growth		
	Residential Customers	Commercial Customers	Industrial Customers	Residential Customers	Commercial Customers	Industrial Customers	Residential Customers	Commercial Customers	Industrial Customers
Mar-33	64,705	7,891	14	66,517	8,112	20	62,726	7,649	8
Apr-33	64,650	7,873	14	66,469	8,094	20	62,663	7,631	8
May-33	64,549	7,864	14	66,374	8,086	21	62,556	7,621	8
Jun-33	64,412	7,851	14	66,242	8,074	21	62,414	7,607	7
Jul-33	64,260	7,827	14	66,094	8,050	21	62,258	7,583	7
Aug-33	64,176	7,821	14	66,016	8,045	21	62,168	7,576	7
Sep-33	64,143	7,809	14	65,990	8,034	21	62,127	7,563	7
Oct-33	64,391	7,824	14	66,254	8,050	21	62,358	7,577	7
Nov-33	64,724	7,859	14	66,605	8,087	21	62,672	7,610	7
Dec-33	65,038	7,902	14	66,936	8,132	21	62,967	7,650	7
Jan-34	65,224	7,936	14	67,136	8,169	21	63,138	7,682	7
Feb-34	65,194	7,944	14	67,114	8,178	21	63,100	7,689	7
Mar-34	65,197	7,944	14	67,125	8,179	21	63,094	7,688	7
Apr-34	65,141	7,926	14	67,076	8,161	21	63,031	7,669	7
May-34	65,038	7,917	14	66,979	8,153	21	62,922	7,659	7
Jun-34	64,899	7,904	14	66,844	8,141	21	62,779	7,646	7
Jul-34	64,744	7,880	14	66,692	8,117	21	62,620	7,622	7
Aug-34	64,659	7,873	14	66,613	8,111	21	62,529	7,614	7
Sep-34	64,625	7,861	14	66,586	8,100	21	62,488	7,601	7
Oct-34	64,870	7,876	14	66,846	8,116	21	62,717	7,615	7
Nov-34	65,202	7,911	14	67,196	8,153	21	63,029	7,647	7
Dec-34	65,514	7,954	14	67,526	8,198	21	63,322	7,688	7
Jan-35	65,698	7,988	14	67,724	8,235	21	63,491	7,720	7
Feb-35	65,667	7,995	14	67,700	8,243	21	63,453	7,726	7
Mar-35	65,668	7,996	14	67,709	8,245	21	63,445	7,726	7
Apr-35	65,610	7,977	14	67,658	8,226	21	63,380	7,706	7
May-35	65,505	7,969	14	67,558	8,219	22	63,270	7,697	7
Jun-35	65,364	7,955	14	67,420	8,206	22	63,126	7,683	6
Jul-35	65,209	7,931	14	67,268	8,182	22	62,968	7,659	6
Aug-35	65,123	7,924	14	67,188	8,176	22	62,876	7,651	6
Sep-35	65,088	7,912	14	67,159	8,164	22	62,834	7,638	6
Oct-35	65,333	7,927	14	67,420	8,181	22	63,062	7,652	6
Nov-35	65,664	7,962	14	67,770	8,218	22	63,373	7,685	6
Dec-35	65,974	8,005	14	68,098	8,263	22	63,664	7,725	6
Jan-36	66,158	8,040	14	68,296	8,299	22	63,833	7,757	6
Feb-36	66,126	8,047	14	68,271	8,308	22	63,794	7,763	6
Mar-36	66,126	8,048	14	68,279	8,310	22	63,785	7,763	6
Apr-36	66,067	8,029	14	68,226	8,291	22	63,720	7,743	6
May-36	65,962	8,020	14	68,125	8,283	22	63,610	7,734	6
Jun-36	65,820	8,006	14	67,987	8,269	22	63,465	7,719	6
Jul-36	65,664	7,983	14	67,833	8,246	22	63,306	7,696	6

	Medford - Expected Growth			Medford - High Growth			Medford - Low Growth		
	Residential Customers	Commercial Customers	Industrial Customers	Residential Customers	Commercial Customers	Industrial Customers	Residential Customers	Commercial Customers	Industrial Customers
Aug-36	65,577	7,976	14	67,751	8,240	22	63,214	7,688	6
Sep-36	65,542	7,963	14	67,723	8,228	22	63,172	7,675	6
Oct-36	65,785	7,978	14	67,982	8,244	22	63,398	7,688	6
Nov-36	66,116	8,013	14	68,332	8,281	22	63,709	7,721	6
Dec-36	66,425	8,056	14	68,659	8,327	22	63,999	7,761	6
Jan-37	66,608	8,090	14	68,856	8,363	22	64,167	7,793	6
Feb-37	66,575	8,097	14	68,830	8,371	22	64,127	7,799	6
Mar-37	66,575	8,098	14	68,837	8,373	22	64,118	7,799	6
Apr-37	66,515	8,079	14	68,783	8,354	22	64,052	7,780	6
May-37	66,408	8,070	14	68,681	8,346	23	63,941	7,770	6
Jun-37	66,266	8,056	14	68,542	8,333	23	63,796	7,756	5
Jul-37	66,109	8,032	14	68,387	8,309	23	63,637	7,732	5
Aug-37	66,020	8,025	14	68,302	8,302	23	63,544	7,724	5
Sep-37	65,983	8,013	14	68,271	8,291	23	63,500	7,711	5
Oct-37	66,226	8,027	14	68,530	8,306	23	63,726	7,724	5
Nov-37	66,555	8,063	14	68,878	8,344	23	64,035	7,758	5
Dec-37	66,863	8,105	14	69,205	8,389	23	64,323	7,797	5
Jan-38	67,044	8,139	14	69,400	8,425	23	64,489	7,829	5
Feb-38	67,010	8,146	14	69,372	8,433	23	64,448	7,835	5
Mar-38	67,008	8,146	14	69,378	8,434	23	64,438	7,834	5
Apr-38	66,947	8,128	14	69,322	8,417	23	64,372	7,816	5
May-38	66,839	8,119	14	69,218	8,408	23	64,260	7,806	5
Jun-38	66,695	8,105	14	69,077	8,395	23	64,114	7,792	5
Jul-38	66,537	8,081	14	68,920	8,371	23	63,954	7,768	5
Aug-38	66,447	8,074	14	68,834	8,364	23	63,860	7,760	5
Sep-38	66,409	8,061	14	68,802	8,352	23	63,816	7,747	5
Oct-38	66,650	8,076	14	69,059	8,368	23	64,040	7,760	5
Nov-38	66,978	8,111	14	69,407	8,405	23	64,347	7,793	5
Dec-38	67,285	8,153	14	69,732	8,450	23	64,634	7,832	5
Jan-39	67,465	8,188	14	69,926	8,486	23	64,800	7,864	5
Feb-39	67,429	8,195	14	69,896	8,495	23	64,757	7,870	5
Mar-39	67,426	8,195	14	69,901	8,495	23	64,747	7,869	5
Apr-39	67,364	8,176	14	69,844	8,477	23	64,679	7,850	5
May-39	67,255	8,167	14	69,738	8,468	24	64,567	7,840	5
Jun-39	67,110	8,153	14	69,595	8,455	24	64,420	7,826	4
Jul-39	66,950	8,129	14	69,437	8,431	24	64,259	7,802	4
Aug-39	66,860	8,122	14	69,350	8,424	24	64,165	7,794	4
Sep-39	66,820	8,109	14	69,316	8,412	24	64,119	7,781	4
Oct-39	67,060	8,124	14	69,572	8,428	24	64,342	7,794	4
Nov-39	67,387	8,159	14	69,919	8,465	24	64,648	7,827	4
Dec-39	67,693	8,201	14	70,243	8,510	24	64,934	7,867	4

	Medford - Expected Growth			Medford - High Growth			Medford - Low Growth		
	Residential Customers	Commercial Customers	Industrial Customers	Residential Customers	Commercial Customers	Industrial Customers	Residential Customers	Commercial Customers	Industrial Customers
Jan-40	67,872	8,235	14	70,436	8,546	24	65,099	7,899	4
Feb-40	67,835	8,242	14	70,405	8,554	24	65,056	7,904	4
Mar-40	67,831	8,242	14	70,408	8,555	24	65,044	7,903	4
Apr-40	67,768	8,223	14	70,350	8,536	24	64,976	7,884	4
May-40	67,658	8,214	14	70,243	8,528	24	64,863	7,875	4
Jun-40	67,512	8,200	14	70,099	8,514	24	64,716	7,860	4
Jul-40	67,351	8,176	14	69,939	8,490	24	64,554	7,837	4
Aug-40	67,259	8,168	14	69,850	8,483	24	64,459	7,828	4
Sep-40	67,219	8,156	14	69,815	8,471	24	64,413	7,816	4
Oct-40	67,458	8,170	14	70,071	8,486	24	64,635	7,828	4

APPENDIX 2.2: CUSTOMER FORECASTS BY REGION ROSEBURG

	Roseburg - Expected Growth			Roseburg - High Growth			Roseburg - Low Growth		
	Residential Customers	Commercial Customers	Industrial Customers	Residential Customers	Commercial Customers	Industrial Customers	Residential Customers	Commercial Customers	Industrial Customers
Nov-19	13,797	2,165	2	13,797	2,165	2	13,797	2,165	2
Dec-19	13,889	2,189	2	13,889	2,189	2	13,889	2,189	2
Jan-20	13,970	2,191	2	13,970	2,191	2	13,970	2,191	2
Feb-20	13,876	2,184	2	13,876	2,184	2	13,876	2,184	2
Mar-20	13,983	2,193	2	13,983	2,193	2	13,983	2,193	2
Apr-20	13,952	2,193	2	13,952	2,193	2	13,952	2,193	2
May-20	13,902	2,169	2	13,902	2,169	2	13,902	2,169	2
Jun-20	13,879	2,169	2	14,010	2,189	2	13,797	2,156	2
Jul-20	13,813	2,157	2	13,953	2,178	2	13,726	2,143	2
Aug-20	13,746	2,164	2	13,894	2,187	2	13,653	2,149	2
Sep-20	13,761	2,162	2	13,919	2,186	2	13,663	2,146	2
Oct-20	13,841	2,163	2	14,009	2,189	2	13,736	2,146	2
Nov-20	13,902	2,176	2	14,080	2,203	2	13,791	2,158	2
Dec-20	14,022	2,191	2	14,211	2,220	2	13,904	2,172	2
Jan-21	14,044	2,190	2	14,243	2,221	2	13,920	2,171	2
Feb-21	14,038	2,196	2	14,246	2,229	2	13,909	2,176	2
Mar-21	14,078	2,194	2	14,296	2,228	2	13,942	2,173	2
Apr-21	14,022	2,189	2	14,249	2,225	2	13,881	2,167	2
May-21	14,002	2,186	2	14,238	2,223	3	13,856	2,163	2
Jun-21	13,946	2,183	2	14,190	2,221	3	13,794	2,160	1
Jul-21	13,880	2,174	2	14,132	2,214	3	13,724	2,150	1
Aug-21	13,833	2,166	2	14,092	2,207	3	13,672	2,141	1
Sep-21	13,824	2,165	2	14,091	2,207	3	13,658	2,139	1
Oct-21	13,900	2,166	2	14,177	2,209	3	13,728	2,139	1
Nov-21	13,993	2,176	2	14,281	2,221	3	13,815	2,149	1
Dec-21	14,096	2,195	2	14,395	2,242	3	13,911	2,166	1
Jan-22	14,130	2,198	2	14,438	2,246	3	13,940	2,169	1
Feb-22	14,134	2,202	2	14,451	2,252	3	13,938	2,172	1
Mar-22	14,142	2,201	2	14,468	2,252	3	13,941	2,170	1
Apr-22	14,107	2,195	2	14,441	2,247	3	13,901	2,163	1
May-22	14,083	2,193	2	14,425	2,247	3	13,872	2,161	1
Jun-22	14,011	2,189	2	14,359	2,244	3	13,796	2,156	1
Jul-22	13,959	2,180	2	14,313	2,236	3	13,741	2,146	1
Aug-22	13,901	2,173	2	14,261	2,230	3	13,679	2,139	1
Sep-22	13,888	2,171	2	14,255	2,229	3	13,662	2,136	1
Oct-22	13,977	2,173	2	14,353	2,232	3	13,745	2,137	1
Nov-22	14,065	2,183	2	14,451	2,243	3	13,828	2,147	1
Dec-22	14,168	2,201	2	14,564	2,263	3	13,925	2,164	1
Jan-23	14,209	2,205	2	14,613	2,267	3	13,961	2,166	1
Feb-23	14,205	2,209	2	14,616	2,273	3	13,952	2,170	1

	Roseburg - Expected Growth			Roseburg - High Growth			Roseburg - Low Growth		
	Residential Customers	Commercial Customers	Industrial Customers	Residential Customers	Commercial Customers	Industrial Customers	Residential Customers	Commercial Customers	Industrial Customers
Mar-23	14,214	2,209	2	14,633	2,274	3	13,957	2,169	1
Apr-23	14,184	2,202	2	14,609	2,268	3	13,923	2,161	1
May-23	14,150	2,200	2	14,581	2,267	3	13,885	2,159	0
Jun-23	14,081	2,197	2	14,517	2,265	4	13,813	2,155	0
Jul-23	14,030	2,187	2	14,471	2,256	4	13,759	2,145	0
Aug-23	13,966	2,180	2	14,412	2,249	4	13,692	2,137	0
Sep-23	13,959	2,178	2	14,412	2,248	4	13,681	2,135	0
Oct-23	14,047	2,180	2	14,509	2,252	4	13,764	2,136	0
Nov-23	14,133	2,190	2	14,605	2,263	4	13,844	2,145	0
Dec-23	14,240	2,208	2	14,722	2,283	4	13,945	2,162	0
Jan-24	14,279	2,211	2	14,770	2,287	4	13,979	2,164	0
Feb-24	14,274	2,215	2	14,771	2,292	4	13,970	2,168	0
Mar-24	14,286	2,214	2	14,791	2,292	4	13,977	2,166	0
Apr-24	14,253	2,208	2	14,763	2,287	4	13,941	2,159	0
May-24	14,219	2,206	2	14,735	2,286	4	13,904	2,157	0
Jun-24	14,152	2,202	2	14,673	2,283	4	13,834	2,152	0
Jul-24	14,098	2,193	2	14,623	2,274	4	13,777	2,143	0
Aug-24	14,035	2,186	2	14,564	2,268	4	13,712	2,135	0
Sep-24	14,029	2,184	2	14,565	2,267	4	13,702	2,133	0
Oct-24	14,115	2,186	2	14,660	2,270	4	13,782	2,134	0
Nov-24	14,202	2,196	2	14,757	2,282	4	13,863	2,143	0
Dec-24	14,310	2,214	2	14,876	2,301	4	13,965	2,160	0
Jan-25	14,348	2,217	2	14,923	2,305	4	13,998	2,162	0
Feb-25	14,344	2,221	2	14,925	2,310	4	13,990	2,166	0
Mar-25	14,356	2,220	2	14,944	2,310	4	13,998	2,164	0
Apr-25	14,321	2,213	2	14,915	2,304	4	13,960	2,157	0
May-25	14,288	2,211	2	14,887	2,303	5	13,924	2,154	0
Jun-25	14,220	2,208	2	14,823	2,301	5	13,853	2,151	0
Jul-25	14,166	2,199	2	14,773	2,293	5	13,797	2,141	0
Aug-25	14,103	2,191	2	14,713	2,285	5	13,732	2,133	0
Sep-25	14,097	2,190	2	14,713	2,285	5	13,722	2,131	0
Oct-25	14,183	2,191	2	14,809	2,287	5	13,802	2,132	0
Nov-25	14,270	2,201	2	14,907	2,299	5	13,883	2,141	0
Dec-25	14,378	2,220	2	15,026	2,320	5	13,985	2,159	0
Jan-26	14,416	2,222	2	15,072	2,323	5	14,018	2,161	0
Feb-26	14,412	2,225	2	15,074	2,327	5	14,010	2,163	0
Mar-26	14,423	2,225	2	15,092	2,328	5	14,017	2,162	0
Apr-26	14,389	2,218	2	15,063	2,322	5	13,980	2,155	0
May-26	14,356	2,216	2	15,035	2,321	5	13,945	2,153	0
Jun-26	14,287	2,213	2	14,969	2,319	5	13,874	2,149	0

	Roseburg - Expected Growth			Roseburg - High Growth			Roseburg - Low Growth		
	Residential Customers	Commercial Customers	Industrial Customers	Residential Customers	Commercial Customers	Industrial Customers	Residential Customers	Commercial Customers	Industrial Customers
Jul-26	14,233	2,203	2	14,919	2,309	5	13,818	2,139	0
Aug-26	14,171	2,196	2	14,860	2,303	5	13,754	2,131	0
Sep-26	14,164	2,194	2	14,859	2,302	5	13,744	2,129	0
Oct-26	14,250	2,196	2	14,955	2,305	5	13,823	2,130	0
Nov-26	14,338	2,206	2	15,053	2,316	5	13,905	2,139	0
Dec-26	14,445	2,224	2	15,172	2,336	5	14,005	2,156	0
Jan-27	14,483	2,226	2	15,218	2,339	5	14,039	2,158	0
Feb-27	14,479	2,230	2	15,220	2,344	5	14,031	2,161	0
Mar-27	14,490	2,229	2	15,238	2,344	5	14,038	2,160	0
Apr-27	14,456	2,223	2	15,209	2,339	5	14,001	2,153	0
May-27	14,423	2,221	2	15,180	2,338	6	13,966	2,151	0
Jun-27	14,354	2,217	2	15,114	2,335	6	13,895	2,146	0
Jul-27	14,300	2,208	2	15,063	2,326	6	13,840	2,137	0
Aug-27	14,237	2,200	2	15,003	2,319	6	13,775	2,129	0
Sep-27	14,230	2,199	2	15,001	2,319	6	13,765	2,127	0
Oct-27	14,317	2,200	2	15,099	2,321	6	13,846	2,128	0
Nov-27	14,404	2,210	2	15,197	2,332	6	13,926	2,137	0
Dec-27	14,512	2,229	2	15,317	2,353	6	14,027	2,155	0
Jan-28	14,550	2,231	2	15,363	2,356	6	14,060	2,156	0
Feb-28	14,546	2,234	2	15,365	2,360	6	14,053	2,159	0
Mar-28	14,557	2,234	2	15,383	2,361	6	14,060	2,158	0
Apr-28	14,523	2,227	2	15,353	2,355	6	14,024	2,151	0
May-28	14,489	2,225	2	15,324	2,354	6	13,987	2,148	0
Jun-28	14,421	2,222	2	15,258	2,351	6	13,918	2,145	0
Jul-28	14,367	2,212	2	15,206	2,342	6	13,863	2,135	0
Aug-28	14,304	2,205	2	15,145	2,335	6	13,799	2,128	0
Sep-28	14,297	2,203	2	15,144	2,334	6	13,789	2,125	0
Oct-28	14,383	2,205	2	15,240	2,337	6	13,868	2,127	0
Nov-28	14,470	2,215	2	15,338	2,348	6	13,949	2,136	0
Dec-28	14,577	2,233	2	15,458	2,368	6	14,049	2,153	0
Jan-29	14,615	2,236	2	15,504	2,372	6	14,082	2,154	0
Feb-29	14,611	2,239	2	15,505	2,376	6	14,075	2,156	0
Mar-29	14,623	2,239	2	15,524	2,377	6	14,083	2,156	0
Apr-29	14,588	2,232	2	15,493	2,370	6	14,046	2,149	0
May-29	14,555	2,230	2	15,463	2,369	7	14,011	2,146	0
Jun-29	14,486	2,227	2	15,396	2,366	7	13,941	2,143	0
Jul-29	14,432	2,217	2	15,343	2,357	7	13,886	2,133	0
Aug-29	14,369	2,210	2	15,282	2,350	7	13,823	2,126	0
Sep-29	14,361	2,208	2	15,278	2,349	7	13,812	2,123	0
Oct-29	14,448	2,210	2	15,376	2,352	7	13,893	2,125	0

	Roseburg - Expected Growth			Roseburg - High Growth			Roseburg - Low Growth		
	Residential Customers	Commercial Customers	Industrial Customers	Residential Customers	Commercial Customers	Industrial Customers	Residential Customers	Commercial Customers	Industrial Customers
Nov-29	14,535	2,220	2	15,473	2,363	7	13,974	2,134	0
Dec-29	14,642	2,238	2	15,592	2,383	7	14,074	2,151	0
Jan-30	14,680	2,240	2	15,638	2,386	7	14,107	2,152	0
Feb-30	14,675	2,243	2	15,638	2,390	7	14,100	2,155	0
Mar-30	14,686	2,243	2	15,655	2,391	7	14,107	2,154	0
Apr-30	14,652	2,236	2	15,624	2,384	7	14,072	2,147	0
May-30	14,618	2,234	2	15,593	2,383	7	14,036	2,145	0
Jun-30	14,549	2,231	2	15,524	2,380	7	13,967	2,141	0
Jul-30	14,494	2,221	2	15,469	2,370	7	13,912	2,132	0
Aug-30	14,431	2,214	2	15,405	2,363	7	13,850	2,125	0
Sep-30	14,423	2,212	2	15,399	2,361	7	13,840	2,122	0
Oct-30	14,509	2,213	2	15,494	2,363	7	13,921	2,123	0
Nov-30	14,596	2,223	2	15,591	2,374	7	14,003	2,132	0
Dec-30	14,702	2,241	2	15,707	2,394	7	14,103	2,149	0
Jan-31	14,739	2,243	2	15,750	2,397	7	14,136	2,151	0
Feb-31	14,735	2,247	2	15,749	2,402	7	14,131	2,155	0
Mar-31	14,745	2,246	2	15,763	2,401	7	14,138	2,153	0
Apr-31	14,710	2,239	2	15,729	2,394	7	14,103	2,146	0
May-31	14,676	2,237	2	15,696	2,392	8	14,068	2,144	0
Jun-31	14,607	2,234	2	15,625	2,390	8	14,000	2,141	0
Jul-31	14,552	2,224	2	15,569	2,379	8	13,946	2,131	0
Aug-31	14,488	2,217	2	15,503	2,372	8	13,883	2,124	0
Sep-31	14,480	2,215	2	15,497	2,370	8	13,874	2,122	0
Oct-31	14,566	2,216	2	15,592	2,372	8	13,955	2,123	0
Nov-31	14,652	2,226	2	15,687	2,383	8	14,036	2,132	0
Dec-31	14,759	2,244	2	15,804	2,403	8	14,137	2,149	0
Jan-32	14,796	2,246	2	15,846	2,405	8	14,171	2,151	0
Feb-32	14,791	2,250	2	15,843	2,410	8	14,165	2,155	0
Mar-32	14,801	2,249	2	15,857	2,410	8	14,173	2,154	0
Apr-32	14,766	2,242	2	15,822	2,402	8	14,138	2,147	0
May-32	14,732	2,240	2	15,788	2,401	8	14,104	2,145	0
Jun-32	14,662	2,236	2	15,716	2,397	8	14,035	2,141	0
Jul-32	14,607	2,227	2	15,659	2,387	8	13,982	2,132	0
Aug-32	14,543	2,219	2	15,592	2,379	8	13,919	2,124	0
Sep-32	14,535	2,218	2	15,586	2,378	8	13,910	2,123	0
Oct-32	14,621	2,219	2	15,680	2,380	8	13,991	2,124	0
Nov-32	14,707	2,229	2	15,775	2,391	8	14,072	2,133	0
Dec-32	14,813	2,247	2	15,891	2,411	8	14,173	2,150	0
Jan-33	14,851	2,249	2	15,934	2,413	8	14,208	2,152	0
Feb-33	14,846	2,252	2	15,930	2,417	8	14,202	2,155	0

	Roseburg - Expected Growth			Roseburg - High Growth			Roseburg - Low Growth		
	Residential Customers	Commercial Customers	Industrial Customers	Residential Customers	Commercial Customers	Industrial Customers	Residential Customers	Commercial Customers	Industrial Customers
Mar-33	14,856	2,251	2	15,943	2,416	8	14,210	2,154	0
Apr-33	14,821	2,245	2	15,908	2,410	8	14,175	2,148	0
May-33	14,786	2,242	2	15,873	2,407	9	14,141	2,145	0
Jun-33	14,716	2,239	2	15,800	2,404	9	14,072	2,141	0
Jul-33	14,661	2,229	2	15,742	2,394	9	14,019	2,132	0
Aug-33	14,597	2,222	2	15,675	2,387	9	13,957	2,125	0
Sep-33	14,589	2,220	2	15,669	2,385	9	13,948	2,123	0
Oct-33	14,675	2,221	2	15,763	2,386	9	14,029	2,124	0
Nov-33	14,761	2,231	2	15,857	2,397	9	14,110	2,133	0
Dec-33	14,867	2,249	2	15,972	2,417	9	14,211	2,150	0
Jan-34	14,904	2,252	2	16,014	2,419	9	14,245	2,152	0
Feb-34	14,899	2,255	2	16,010	2,423	9	14,239	2,155	0
Mar-34	14,909	2,255	2	16,023	2,423	9	14,248	2,155	0
Apr-34	14,874	2,248	2	15,987	2,416	9	14,214	2,148	0
May-34	14,839	2,246	2	15,951	2,414	9	14,179	2,146	0
Jun-34	14,769	2,242	2	15,878	2,410	9	14,111	2,142	0
Jul-34	14,714	2,233	2	15,820	2,401	9	14,058	2,133	0
Aug-34	14,650	2,225	2	15,753	2,392	9	13,996	2,125	0
Sep-34	14,642	2,223	2	15,746	2,390	9	13,987	2,123	0
Oct-34	14,727	2,225	2	15,838	2,393	9	14,068	2,125	0
Nov-34	14,813	2,234	2	15,932	2,402	9	14,149	2,134	0
Dec-34	14,919	2,252	2	16,048	2,422	9	14,250	2,151	0
Jan-35	14,956	2,254	2	16,089	2,425	9	14,284	2,153	0
Feb-35	14,951	2,258	2	16,085	2,429	9	14,279	2,156	0
Mar-35	14,961	2,257	2	16,097	2,428	9	14,287	2,155	0
Apr-35	14,926	2,250	2	16,061	2,421	9	14,253	2,149	0
May-35	14,891	2,248	2	16,025	2,419	10	14,219	2,146	0
Jun-35	14,821	2,244	2	15,951	2,415	10	14,151	2,143	0
Jul-35	14,766	2,235	2	15,893	2,406	10	14,098	2,134	0
Aug-35	14,702	2,227	2	15,826	2,397	10	14,036	2,126	0
Sep-35	14,694	2,225	2	15,818	2,395	10	14,028	2,124	0
Oct-35	14,779	2,227	2	15,911	2,398	10	14,108	2,126	0
Nov-35	14,865	2,236	2	16,005	2,407	10	14,189	2,134	0
Dec-35	14,971	2,254	2	16,121	2,427	10	14,290	2,151	0
Jan-36	15,008	2,256	2	16,162	2,430	10	14,324	2,153	0
Feb-36	15,003	2,260	2	16,158	2,434	10	14,319	2,157	0
Mar-36	15,013	2,259	2	16,170	2,433	10	14,328	2,156	0
Apr-36	14,978	2,252	2	16,134	2,426	10	14,293	2,149	0
May-36	14,943	2,250	2	16,097	2,424	10	14,259	2,147	0
Jun-36	14,873	2,246	2	16,023	2,420	10	14,192	2,143	0
Jul-36	14,818	2,237	2	15,965	2,410	10	14,138	2,135	0

	Roseburg - Expected Growth			Roseburg - High Growth			Roseburg - Low Growth		
	Residential Customers	Commercial Customers	Industrial Customers	Residential Customers	Commercial Customers	Industrial Customers	Residential Customers	Commercial Customers	Industrial Customers
Aug-36	14,754	2,229	2	15,898	2,402	10	14,077	2,127	0
Sep-36	14,745	2,227	2	15,889	2,400	10	14,067	2,125	0
Oct-36	14,831	2,229	2	15,983	2,402	10	14,149	2,127	0
Nov-36	14,917	2,238	2	16,078	2,412	10	14,230	2,135	0
Dec-36	15,023	2,257	2	16,193	2,433	10	14,330	2,153	0
Jan-37	15,060	2,259	2	16,234	2,435	10	14,365	2,154	0
Feb-37	15,055	2,263	2	16,230	2,439	10	14,359	2,158	0
Mar-37	15,065	2,262	2	16,242	2,438	10	14,368	2,157	0
Apr-37	15,029	2,255	2	16,205	2,431	10	14,333	2,150	0
May-37	14,994	2,253	2	16,169	2,429	11	14,299	2,148	0
Jun-37	14,924	2,249	2	16,094	2,425	11	14,231	2,144	0
Jul-37	14,869	2,240	2	16,037	2,415	11	14,178	2,135	0
Aug-37	14,806	2,232	2	15,971	2,407	11	14,117	2,128	0
Sep-37	14,797	2,230	2	15,963	2,405	11	14,107	2,126	0
Oct-37	14,883	2,232	2	16,058	2,408	11	14,188	2,127	0
Nov-37	14,969	2,242	2	16,153	2,419	11	14,269	2,137	0
Dec-37	15,075	2,260	2	16,269	2,438	11	14,369	2,154	0
Jan-38	15,112	2,262	2	16,311	2,441	11	14,403	2,156	0
Feb-38	15,107	2,265	2	16,307	2,445	11	14,397	2,158	0
Mar-38	15,117	2,264	2	16,320	2,444	11	14,406	2,157	0
Apr-38	15,082	2,257	2	16,284	2,437	11	14,371	2,150	0
May-38	15,048	2,255	2	16,250	2,435	11	14,338	2,148	0
Jun-38	14,978	2,252	2	16,176	2,432	11	14,270	2,145	0
Jul-38	14,923	2,242	2	16,119	2,421	11	14,216	2,136	0
Aug-38	14,859	2,235	2	16,052	2,414	11	14,154	2,129	0
Sep-38	14,851	2,233	2	16,045	2,412	11	14,145	2,127	0
Oct-38	14,937	2,234	2	16,141	2,414	11	14,226	2,127	0
Nov-38	15,023	2,244	2	16,236	2,425	11	14,307	2,137	0
Dec-38	15,129	2,262	2	16,353	2,445	11	14,406	2,154	0
Jan-39	15,166	2,264	2	16,395	2,448	11	14,440	2,156	0
Feb-39	15,161	2,267	2	16,392	2,451	11	14,434	2,158	0
Mar-39	15,171	2,267	2	16,405	2,451	11	14,442	2,158	0
Apr-39	15,136	2,260	2	16,369	2,444	11	14,408	2,151	0
May-39	15,102	2,258	2	16,335	2,442	12	14,374	2,149	0
Jun-39	15,032	2,254	2	16,261	2,438	12	14,306	2,145	0
Jul-39	14,977	2,245	2	16,204	2,429	12	14,253	2,137	0
Aug-39	14,913	2,237	2	16,136	2,421	12	14,191	2,129	0
Sep-39	14,905	2,235	2	16,130	2,419	12	14,182	2,127	0
Oct-39	14,991	2,237	2	16,225	2,421	12	14,263	2,128	0
Nov-39	15,077	2,246	2	16,320	2,431	12	14,344	2,137	0
Dec-39	15,183	2,265	2	16,436	2,452	12	14,444	2,155	0

	Roseburg - Expected Growth			Roseburg - High Growth			Roseburg - Low Growth		
	Residential Customers	Commercial Customers	Industrial Customers	Residential Customers	Commercial Customers	Industrial Customers	Residential Customers	Commercial Customers	Industrial Customers
Jan-40	15,220	2,266	2	16,478	2,454	12	14,478	2,156	0
Feb-40	15,215	2,270	2	16,475	2,458	12	14,472	2,160	0
Mar-40	15,225	2,269	2	16,488	2,458	12	14,480	2,158	0
Apr-40	15,190	2,262	2	16,452	2,450	12	14,446	2,152	0
May-40	15,155	2,260	2	16,416	2,448	12	14,412	2,150	0
Jun-40	15,085	2,256	2	16,342	2,444	12	14,344	2,146	0
Jul-40	15,030	2,247	2	16,284	2,435	12	14,291	2,137	0
Aug-40	14,966	2,239	2	16,216	2,426	12	14,229	2,129	0
Sep-40	14,958	2,238	2	16,209	2,426	12	14,221	2,128	0
Oct-40	15,043	2,239	2	16,302	2,427	12	14,301	2,129	0

APPENDIX 2.2: CUSTOMER FORECASTS BY REGION KLAMATH FALLS

	Klamath Falls - Expected Growth			Klamath Falls - High Growth			Klamath Falls - Low Growth		
	Residential Customers	Commercial Customers	Industrial Customers	Residential Customers	Commercial Customers	Industrial Customers	Residential Customers	Commercial Customers	Industrial Customers
Nov-19	15,093	1,780	6	15,093	1,780	6	15,093	1,780	6
Dec-19	15,192	1,787	6	15,192	1,787	6	15,192	1,787	6
Jan-20	15,173	1,783	6	15,173	1,783	6	15,173	1,783	6
Feb-20	15,203	1,793	6	15,203	1,793	6	15,203	1,793	6
Mar-20	15,200	1,795	6	15,200	1,795	6	15,200	1,795	6
Apr-20	15,199	1,791	6	15,199	1,791	6	15,199	1,791	6
May-20	15,227	1,787	6	15,227	1,787	6	15,227	1,787	6
Jun-20	15,157	1,780	6	15,383	1,807	6	14,880	1,748	6
Jul-20	15,093	1,778	6	15,333	1,807	6	14,799	1,744	6
Aug-20	15,024	1,774	6	15,277	1,804	6	14,713	1,738	6
Sep-20	15,012	1,769	6	15,280	1,801	6	14,684	1,731	6
Oct-20	15,143	1,775	6	15,428	1,809	6	14,794	1,735	6
Nov-20	15,262	1,785	6	15,564	1,821	6	14,892	1,742	6
Dec-20	15,368	1,793	6	15,688	1,831	6	14,978	1,748	6
Jan-21	15,429	1,806	6	15,765	1,845	6	15,019	1,758	6
Feb-21	15,444	1,809	6	15,796	1,850	6	15,015	1,758	6
Mar-21	15,449	1,805	6	15,816	1,847	6	15,002	1,752	6
Apr-21	15,430	1,800	6	15,812	1,844	6	14,965	1,745	6
May-21	15,402	1,796	6	15,799	1,842	7	14,920	1,739	6
Jun-21	15,323	1,793	6	15,733	1,840	7	14,826	1,734	5
Jul-21	15,237	1,786	6	15,657	1,835	7	14,728	1,726	5
Aug-21	15,167	1,780	6	15,598	1,830	7	14,645	1,718	5
Sep-21	15,161	1,777	6	15,604	1,828	7	14,625	1,714	5
Oct-21	15,305	1,784	6	15,765	1,837	7	14,749	1,719	5
Nov-21	15,441	1,794	6	15,917	1,849	7	14,865	1,727	5
Dec-21	15,552	1,806	6	16,045	1,863	7	14,957	1,736	5
Jan-22	15,617	1,818	6	16,125	1,877	7	15,005	1,747	5
Feb-22	15,628	1,821	6	16,149	1,882	7	15,001	1,748	5
Mar-22	15,625	1,819	6	16,159	1,881	7	14,983	1,744	5
Apr-22	15,597	1,814	6	16,142	1,878	7	14,941	1,738	5
May-22	15,561	1,810	6	16,118	1,875	7	14,892	1,732	5
Jun-22	15,478	1,805	6	16,045	1,871	7	14,798	1,726	5
Jul-22	15,390	1,797	6	15,963	1,864	7	14,703	1,717	5
Aug-22	15,321	1,792	6	15,900	1,860	7	14,627	1,711	5
Sep-22	15,318	1,790	6	15,906	1,859	7	14,613	1,708	5
Oct-22	15,463	1,797	6	16,066	1,867	7	14,741	1,713	5
Nov-22	15,600	1,808	6	16,218	1,880	7	14,861	1,723	5
Dec-22	15,710	1,819	6	16,341	1,892	7	14,955	1,732	5
Jan-23	15,772	1,832	6	16,415	1,907	7	15,003	1,743	5
Feb-23	15,780	1,835	6	16,433	1,911	7	15,000	1,745	5

	Klamath Falls - Expected Growth			Klamath Falls - High Growth			Klamath Falls - Low Growth		
	Residential Customers	Commercial Customers	Industrial Customers	Residential Customers	Commercial Customers	Industrial Customers	Residential Customers	Commercial Customers	Industrial Customers
Mar-23	15,773	1,833	6	16,435	1,910	7	14,983	1,741	5
Apr-23	15,742	1,828	6	16,412	1,906	7	14,943	1,735	5
May-23	15,703	1,823	6	16,381	1,902	8	14,895	1,729	4
Jun-23	15,619	1,818	6	16,302	1,898	8	14,805	1,724	4
Jul-23	15,531	1,811	6	16,218	1,891	8	14,713	1,716	4
Aug-23	15,462	1,806	6	16,153	1,887	8	14,639	1,710	4
Sep-23	15,459	1,803	6	16,158	1,885	8	14,628	1,706	4
Oct-23	15,604	1,811	6	16,317	1,894	8	14,757	1,713	4
Nov-23	15,740	1,821	6	16,467	1,905	8	14,877	1,721	4
Dec-23	15,849	1,832	6	16,588	1,918	8	14,971	1,731	4
Jan-24	15,910	1,846	6	16,660	1,933	8	15,020	1,742	4
Feb-24	15,917	1,849	6	16,675	1,937	8	15,018	1,744	4
Mar-24	15,908	1,846	6	16,673	1,935	8	15,001	1,740	4
Apr-24	15,876	1,841	6	16,647	1,930	8	14,962	1,735	4
May-24	15,837	1,837	6	16,614	1,927	8	14,916	1,730	4
Jun-24	15,752	1,831	6	16,533	1,922	8	14,828	1,723	4
Jul-24	15,664	1,824	6	16,446	1,915	8	14,738	1,716	4
Aug-24	15,594	1,819	6	16,379	1,910	8	14,665	1,710	4
Sep-24	15,590	1,817	6	16,381	1,909	8	14,655	1,708	4
Oct-24	15,734	1,824	6	16,538	1,917	8	14,783	1,714	4
Nov-24	15,870	1,834	6	16,688	1,928	8	14,904	1,722	4
Dec-24	15,978	1,846	6	16,807	1,942	8	14,999	1,733	4
Jan-25	16,038	1,858	6	16,877	1,955	8	15,048	1,743	4
Feb-25	16,044	1,861	6	16,889	1,959	8	15,047	1,745	4
Mar-25	16,035	1,858	6	16,886	1,957	8	15,031	1,742	4
Apr-25	16,002	1,853	6	16,858	1,952	8	14,993	1,736	4
May-25	15,962	1,849	6	16,822	1,949	9	14,949	1,732	3
Jun-25	15,877	1,843	6	16,738	1,943	9	14,862	1,725	3
Jul-25	15,788	1,836	6	16,649	1,936	9	14,774	1,718	3
Aug-25	15,717	1,831	6	16,579	1,931	9	14,702	1,713	3
Sep-25	15,713	1,829	6	16,580	1,930	9	14,693	1,710	3
Oct-25	15,857	1,836	6	16,736	1,938	9	14,823	1,716	3
Nov-25	15,992	1,847	6	16,884	1,950	9	14,943	1,726	3
Dec-25	16,099	1,858	6	17,001	1,962	9	15,038	1,736	3
Jan-26	16,158	1,870	6	17,069	1,975	9	15,088	1,746	3
Feb-26	16,164	1,873	6	17,080	1,979	9	15,088	1,748	3
Mar-26	16,154	1,870	6	17,074	1,976	9	15,073	1,745	3
Apr-26	16,120	1,865	6	17,043	1,972	9	15,036	1,740	3
May-26	16,080	1,861	6	17,005	1,968	9	14,994	1,735	3
Jun-26	15,993	1,855	6	16,918	1,962	9	14,907	1,729	3

	Klamath Falls - Expected Growth			Klamath Falls - High Growth			Klamath Falls - Low Growth		
	Residential Customers	Commercial Customers	Industrial Customers	Residential Customers	Commercial Customers	Industrial Customers	Residential Customers	Commercial Customers	Industrial Customers
Jul-26	15,904	1,848	6	16,828	1,955	9	14,820	1,722	3
Aug-26	15,833	1,843	6	16,756	1,950	9	14,750	1,717	3
Sep-26	15,828	1,841	6	16,754	1,949	9	14,742	1,715	3
Oct-26	15,971	1,848	6	16,909	1,956	9	14,871	1,721	3
Nov-26	16,106	1,858	6	17,056	1,967	9	14,993	1,730	3
Dec-26	16,213	1,870	6	17,173	1,981	9	15,089	1,740	3
Jan-27	16,271	1,882	6	17,238	1,993	9	15,139	1,751	3
Feb-27	16,276	1,885	6	17,247	1,997	9	15,139	1,753	3
Mar-27	16,265	1,882	6	17,239	1,994	9	15,125	1,750	3
Apr-27	16,232	1,877	6	17,207	1,989	9	15,090	1,745	3
May-27	16,190	1,873	6	17,166	1,985	9	15,047	1,740	2
Jun-27	16,104	1,867	6	17,079	1,980	10	14,963	1,734	2
Jul-27	16,014	1,860	6	16,986	1,972	10	14,877	1,728	2
Aug-27	15,942	1,855	6	16,912	1,967	10	14,807	1,723	2
Sep-27	15,937	1,852	6	16,909	1,964	10	14,800	1,719	2
Oct-27	16,079	1,860	6	17,062	1,973	10	14,929	1,727	2
Nov-27	16,213	1,870	6	17,207	1,984	10	15,051	1,736	2
Dec-27	16,320	1,881	6	17,323	1,996	10	15,147	1,745	2
Jan-28	16,378	1,893	6	17,387	2,010	10	15,198	1,757	2
Feb-28	16,382	1,896	6	17,394	2,013	10	15,199	1,759	2
Mar-28	16,371	1,893	6	17,385	2,010	10	15,186	1,756	2
Apr-28	16,337	1,888	6	17,351	2,005	10	15,152	1,751	2
May-28	16,295	1,884	6	17,309	2,001	10	15,110	1,747	2
Jun-28	16,208	1,878	6	17,219	1,995	10	15,027	1,741	2
Jul-28	16,118	1,871	6	17,125	1,988	10	14,942	1,735	2
Aug-28	16,045	1,866	6	17,049	1,983	10	14,872	1,730	2
Sep-28	16,040	1,863	6	17,046	1,980	10	14,866	1,727	2
Oct-28	16,182	1,870	6	17,198	1,987	10	14,996	1,733	2
Nov-28	16,315	1,881	6	17,341	1,999	10	15,117	1,743	2
Dec-28	16,421	1,892	6	17,455	2,011	10	15,214	1,753	2
Jan-29	16,479	1,904	6	17,519	2,024	10	15,266	1,763	2
Feb-29	16,483	1,907	6	17,525	2,027	10	15,268	1,766	2
Mar-29	16,472	1,905	6	17,515	2,025	10	15,256	1,764	2
Apr-29	16,437	1,900	6	17,479	2,020	10	15,221	1,759	2
May-29	16,395	1,895	6	17,436	2,015	11	15,181	1,754	1
Jun-29	16,307	1,889	6	17,344	2,009	11	15,098	1,748	1
Jul-29	16,216	1,882	6	17,247	2,001	11	15,013	1,742	1
Aug-29	16,143	1,877	6	17,170	1,996	11	14,945	1,737	1
Sep-29	16,137	1,875	6	17,163	1,994	11	14,940	1,735	1
Oct-29	16,279	1,882	6	17,315	2,001	11	15,071	1,742	1

	Klamath Falls - Expected Growth			Klamath Falls - High Growth			Klamath Falls - Low Growth		
	Residential Customers	Commercial Customers	Industrial Customers	Residential Customers	Commercial Customers	Industrial Customers	Residential Customers	Commercial Customers	Industrial Customers
Nov-29	16,411	1,892	6	17,455	2,012	11	15,193	1,751	1
Dec-29	16,517	1,904	6	17,568	2,025	11	15,291	1,762	1
Jan-30	16,574	1,915	6	17,629	2,037	11	15,344	1,773	1
Feb-30	16,577	1,918	6	17,632	2,040	11	15,347	1,776	1
Mar-30	16,565	1,915	6	17,619	2,037	11	15,335	1,773	1
Apr-30	16,529	1,910	6	17,581	2,031	11	15,302	1,768	1
May-30	16,486	1,905	6	17,536	2,026	11	15,262	1,763	1
Jun-30	16,398	1,900	6	17,442	2,021	11	15,180	1,759	1
Jul-30	16,307	1,893	6	17,347	2,014	11	15,096	1,752	1
Aug-30	16,234	1,888	6	17,271	2,008	11	15,028	1,748	1
Sep-30	16,227	1,885	6	17,265	2,005	11	15,021	1,745	1
Oct-30	16,369	1,892	6	17,418	2,013	11	15,152	1,751	1
Nov-30	16,501	1,903	6	17,560	2,025	11	15,274	1,761	1
Dec-30	16,606	1,914	6	17,673	2,037	11	15,371	1,772	1
Jan-31	16,663	1,925	6	17,735	2,049	11	15,424	1,782	1
Feb-31	16,666	1,928	6	17,740	2,053	11	15,426	1,785	1
Mar-31	16,654	1,925	6	17,729	2,050	11	15,415	1,782	1
Apr-31	16,618	1,920	6	17,692	2,045	11	15,381	1,777	1
May-31	16,575	1,916	6	17,648	2,040	12	15,341	1,774	0
Jun-31	16,486	1,910	6	17,555	2,034	12	15,258	1,768	0
Jul-31	16,395	1,903	6	17,459	2,027	12	15,174	1,762	0
Aug-31	16,322	1,898	6	17,382	2,022	12	15,106	1,757	0
Sep-31	16,316	1,895	6	17,377	2,019	12	15,100	1,754	0
Oct-31	16,457	1,902	6	17,528	2,026	12	15,231	1,761	0
Nov-31	16,590	1,913	6	17,671	2,038	12	15,354	1,771	0
Dec-31	16,695	1,924	6	17,783	2,050	12	15,451	1,781	0
Jan-32	16,752	1,936	6	17,845	2,062	12	15,503	1,792	0
Feb-32	16,755	1,940	6	17,849	2,067	12	15,506	1,795	0
Mar-32	16,742	1,937	6	17,836	2,064	12	15,494	1,792	0
Apr-32	16,707	1,932	6	17,800	2,058	12	15,461	1,788	0
May-32	16,664	1,927	6	17,755	2,053	12	15,421	1,783	0
Jun-32	16,575	1,921	6	17,661	2,047	12	15,338	1,778	0
Jul-32	16,484	1,914	6	17,566	2,040	12	15,254	1,771	0
Aug-32	16,411	1,909	6	17,489	2,034	12	15,186	1,766	0
Sep-32	16,405	1,907	6	17,484	2,032	12	15,180	1,765	0
Oct-32	16,546	1,914	6	17,636	2,040	12	15,311	1,771	0
Nov-32	16,679	1,924	6	17,779	2,051	12	15,433	1,780	0
Dec-32	16,784	1,936	6	17,892	2,064	12	15,530	1,791	0
Jan-33	16,840	1,948	6	17,954	2,076	12	15,582	1,802	0
Feb-33	16,843	1,951	6	17,958	2,080	12	15,584	1,805	0

	Klamath Falls - Expected Growth			Klamath Falls - High Growth			Klamath Falls - Low Growth		
	Residential Customers	Commercial Customers	Industrial Customers	Residential Customers	Commercial Customers	Industrial Customers	Residential Customers	Commercial Customers	Industrial Customers
Mar-33	16,831	1,948	6	17,947	2,077	12	15,573	1,802	0
Apr-33	16,796	1,943	6	17,911	2,072	12	15,540	1,797	0
May-33	16,752	1,938	6	17,865	2,066	13	15,499	1,793	0
Jun-33	16,664	1,933	6	17,773	2,061	13	15,418	1,788	0
Jul-33	16,573	1,926	6	17,678	2,054	13	15,333	1,782	0
Aug-33	16,500	1,921	6	17,602	2,049	13	15,265	1,777	0
Sep-33	16,493	1,918	6	17,596	2,046	13	15,258	1,774	0
Oct-33	16,634	1,925	6	17,748	2,054	13	15,389	1,780	0
Nov-33	16,767	1,936	6	17,892	2,065	13	15,511	1,791	0
Dec-33	16,872	1,947	6	18,006	2,077	13	15,608	1,801	0
Jan-34	16,928	1,958	6	18,067	2,090	13	15,660	1,811	0
Feb-34	16,931	1,961	6	18,073	2,093	13	15,662	1,814	0
Mar-34	16,919	1,958	6	18,062	2,090	13	15,651	1,811	0
Apr-34	16,883	1,953	6	18,025	2,085	13	15,617	1,807	0
May-34	16,840	1,949	6	17,981	2,081	13	15,577	1,803	0
Jun-34	16,752	1,943	6	17,889	2,075	13	15,495	1,797	0
Jul-34	16,660	1,936	6	17,794	2,068	13	15,409	1,791	0
Aug-34	16,587	1,931	6	17,720	2,063	13	15,341	1,786	0
Sep-34	16,580	1,928	6	17,716	2,060	13	15,334	1,783	0
Oct-34	16,721	1,935	6	17,870	2,068	13	15,464	1,790	0
Nov-34	16,853	1,946	6	18,015	2,080	13	15,585	1,800	0
Dec-34	16,958	1,957	6	18,131	2,093	13	15,681	1,810	0
Jan-35	17,015	1,969	6	18,196	2,105	13	15,733	1,821	0
Feb-35	17,017	1,972	6	18,202	2,109	13	15,735	1,823	0
Mar-35	17,005	1,970	6	18,192	2,107	13	15,723	1,821	0
Apr-35	16,969	1,964	6	18,158	2,101	13	15,689	1,816	0
May-35	16,926	1,960	6	18,115	2,098	13	15,648	1,812	0
Jun-35	16,837	1,954	6	18,024	2,092	14	15,565	1,806	0
Jul-35	16,745	1,947	6	17,929	2,084	14	15,480	1,800	0
Aug-35	16,672	1,942	6	17,854	2,079	14	15,412	1,795	0
Sep-35	16,665	1,939	6	17,849	2,077	14	15,405	1,792	0
Oct-35	16,807	1,947	6	18,005	2,086	14	15,535	1,800	0
Nov-35	16,939	1,957	6	18,150	2,097	14	15,657	1,809	0
Dec-35	17,044	1,968	6	18,265	2,109	14	15,753	1,819	0
Jan-36	17,100	1,979	6	18,329	2,122	14	15,804	1,829	0
Feb-36	17,103	1,983	6	18,335	2,126	14	15,806	1,833	0
Mar-36	17,090	1,980	6	18,325	2,124	14	15,794	1,830	0
Apr-36	17,055	1,975	6	18,291	2,119	14	15,761	1,826	0
May-36	17,011	1,970	6	18,247	2,114	14	15,719	1,821	0
Jun-36	16,923	1,965	6	18,156	2,109	14	15,638	1,816	0
Jul-36	16,831	1,958	6	18,060	2,101	14	15,552	1,810	0

	Klamath Falls - Expected Growth			Klamath Falls - High Growth			Klamath Falls - Low Growth		
	Residential Customers	Commercial Customers	Industrial Customers	Residential Customers	Commercial Customers	Industrial Customers	Residential Customers	Commercial Customers	Industrial Customers
Aug-36	16,758	1,952	6	17,984	2,095	14	15,484	1,804	0
Sep-36	16,751	1,950	6	17,980	2,093	14	15,477	1,802	0
Oct-36	16,892	1,957	6	18,134	2,101	14	15,607	1,809	0
Nov-36	17,025	1,967	6	18,279	2,112	14	15,729	1,818	0
Dec-36	17,130	1,979	6	18,395	2,126	14	15,826	1,829	0
Jan-37	17,186	1,991	6	18,458	2,138	14	15,877	1,839	0
Feb-37	17,189	1,994	6	18,464	2,142	14	15,879	1,842	0
Mar-37	17,177	1,991	6	18,454	2,139	14	15,868	1,839	0
Apr-37	17,141	1,986	6	18,418	2,134	14	15,834	1,835	0
May-37	17,098	1,982	6	18,375	2,130	14	15,793	1,831	0
Jun-37	17,009	1,976	6	18,282	2,124	15	15,711	1,825	0
Jul-37	16,918	1,969	6	18,185	2,117	15	15,627	1,819	0
Aug-37	16,845	1,964	6	18,107	2,111	15	15,559	1,814	0
Sep-37	16,838	1,961	6	18,101	2,108	15	15,552	1,811	0
Oct-37	16,980	1,968	6	18,254	2,116	15	15,683	1,818	0
Nov-37	17,112	1,979	6	18,397	2,128	15	15,805	1,828	0
Dec-37	17,218	1,990	6	18,512	2,140	15	15,903	1,838	0
Jan-38	17,274	2,002	6	18,573	2,152	15	15,954	1,849	0
Feb-38	17,278	2,005	6	18,578	2,156	15	15,958	1,852	0
Mar-38	17,265	2,002	6	18,565	2,152	15	15,946	1,849	0
Apr-38	17,230	1,997	6	18,528	2,147	15	15,913	1,844	0
May-38	17,187	1,993	6	18,483	2,143	15	15,873	1,840	0
Jun-38	17,098	1,987	6	18,388	2,137	15	15,791	1,835	0
Jul-38	17,008	1,980	6	18,288	2,129	15	15,709	1,828	0
Aug-38	16,935	1,975	6	18,207	2,123	15	15,642	1,824	0
Sep-38	16,929	1,972	6	18,198	2,119	15	15,637	1,821	0
Oct-38	17,071	1,980	6	18,347	2,128	15	15,768	1,829	0
Nov-38	17,204	1,990	6	18,487	2,138	15	15,892	1,838	0
Dec-38	17,310	2,001	6	18,598	2,150	15	15,990	1,848	0
Jan-39	17,367	2,012	6	18,657	2,162	15	16,043	1,859	0
Feb-39	17,370	2,016	6	18,657	2,166	15	16,047	1,863	0
Mar-39	17,359	2,013	6	18,642	2,162	15	16,037	1,860	0
Apr-39	17,324	2,008	6	18,602	2,157	15	16,005	1,855	0
May-39	17,281	2,003	6	18,553	2,151	15	15,966	1,851	0
Jun-39	17,193	1,998	6	18,456	2,145	16	15,885	1,846	0
Jul-39	17,102	1,991	6	18,357	2,138	16	15,801	1,840	0
Aug-39	17,029	1,986	6	18,278	2,132	16	15,734	1,835	0
Sep-39	17,023	1,983	6	18,271	2,129	16	15,729	1,833	0
Oct-39	17,165	1,990	6	18,422	2,136	16	15,860	1,839	0
Nov-39	17,298	2,001	6	18,564	2,148	16	15,983	1,849	0
Dec-39	17,403	2,012	6	18,676	2,160	16	16,080	1,859	0

	Klamath Falls - Expected Growth			Klamath Falls - High Growth			Klamath Falls - Low Growth		
	Residential Customers	Commercial Customers	Industrial Customers	Residential Customers	Commercial Customers	Industrial Customers	Residential Customers	Commercial Customers	Industrial Customers
Jan-40	17,460	2,024	6	18,736	2,172	16	16,133	1,870	0
Feb-40	17,463	2,027	6	18,738	2,175	16	16,136	1,873	0
Mar-40	17,451	2,024	6	18,725	2,172	16	16,125	1,870	0
Apr-40	17,416	2,019	6	18,686	2,166	16	16,093	1,866	0
May-40	17,373	2,015	6	18,639	2,162	16	16,053	1,862	0
Jun-40	17,285	2,009	6	18,544	2,155	16	15,972	1,856	0
Jul-40	17,194	2,002	6	18,447	2,148	16	15,888	1,850	0
Aug-40	17,121	1,997	6	18,370	2,143	16	15,820	1,845	0
Sep-40	17,114	1,994	6	18,363	2,140	16	15,814	1,842	0
Oct-40	17,256	2,001	6	18,517	2,147	16	15,945	1,849	0

APPENDIX 2.2: CUSTOMER FORECASTS BY REGION LA GRANDE

	La Grande - Expected Growth			La Grande - High Growth			La Grande - Low Growth		
	Residential Customers	Commercial Customers	Industrial Customers	Residential Customers	Commercial Customers	Industrial Customers	Residential Customers	Commercial Customers	Industrial Customers
Nov-19	6,772	937	2	6,772	937	2	6,772	937	2
Dec-19	6,794	943	2	6,794	943	2	6,794	943	2
Jan-20	6,801	933	1	6,801	933	1	6,801	933	1
Feb-20	6,795	934	1	6,795	934	1	6,795	934	1
Mar-20	6,801	933	1	6,801	933	1	6,801	933	1
Apr-20	6,781	937	1	6,781	937	1	6,781	937	1
May-20	6,773	936	2	6,773	936	2	6,773	936	2
Jun-20	6,761	931	2	6,821	939	3	6,681	920	2
Jul-20	6,722	926	2	6,786	935	3	6,637	914	2
Aug-20	6,718	930	3	6,786	939	5	6,627	917	4
Sep-20	6,707	929	6	6,780	939	6	6,611	915	5
Oct-20	6,751	928	4	6,829	939	3	6,648	914	2
Nov-20	6,810	928	3	6,893	939	3	6,701	913	2
Dec-20	6,837	935	2	6,925	947	3	6,721	919	2
Jan-21	6,854	943	1	6,946	956	2	6,732	926	1
Feb-21	6,847	941	1	6,944	955	2	6,719	924	1
Mar-21	6,839	941	1	6,940	955	2	6,706	922	1
Apr-21	6,823	939	1	6,929	954	2	6,684	920	1
May-21	6,814	940	1	6,924	955	3	6,669	920	2
Jun-21	6,792	938	2	6,906	953	3	6,642	917	1
Jul-21	6,752	933	2	6,870	949	3	6,598	911	1
Aug-21	6,742	932	3	6,864	948	5	6,582	910	3
Sep-21	6,734	931	6	6,860	948	6	6,569	908	4
Oct-21	6,781	934	5	6,912	952	3	6,610	911	1
Nov-21	6,847	934	3	6,983	953	3	6,669	910	1
Dec-21	6,882	940	2	7,023	960	3	6,697	915	1
Jan-22	6,902	942	1	7,048	962	2	6,711	916	0
Feb-22	6,897	948	1	7,047	968	2	6,701	921	0
Mar-22	6,886	946	1	7,040	967	2	6,685	919	0
Apr-22	6,869	945	1	7,027	966	2	6,663	916	0
May-22	6,857	942	2	7,019	965	3	6,646	913	1
Jun-22	6,830	941	2	6,996	964	4	6,614	911	1
Jul-22	6,787	938	2	6,955	961	4	6,568	908	1
Aug-22	6,773	937	3	6,945	961	6	6,550	907	3
Sep-22	6,765	934	6	6,940	959	7	6,537	903	4
Oct-22	6,815	937	5	6,995	962	4	6,581	905	1
Nov-22	6,884	939	3	7,070	964	4	6,643	906	1
Dec-22	6,923	946	2	7,114	972	4	6,676	912	1
Jan-23	6,947	947	1	7,142	974	3	6,694	913	0
Feb-23	6,943	950	1	7,142	977	3	6,685	914	0

	La Grande - Expected Growth			La Grande - High Growth			La Grande - Low Growth		
	Residential Customers	Commercial Customers	Industrial Customers	Residential Customers	Commercial Customers	Industrial Customers	Residential Customers	Commercial Customers	Industrial Customers
Mar-23	6,932	951	1	7,134	979	3	6,670	915	0
Apr-23	6,914	949	1	7,119	978	3	6,648	913	0
May-23	6,899	948	1	7,108	976	4	6,629	910	1
Jun-23	6,869	945	2	7,081	974	4	6,595	907	0
Jul-23	6,824	942	2	7,038	971	4	6,547	904	0
Aug-23	6,807	942	3	7,024	972	6	6,527	903	2
Sep-23	6,800	940	6	7,020	970	7	6,515	900	3
Oct-23	6,851	942	5	7,077	973	4	6,560	902	0
Nov-23	6,921	943	3	7,153	974	4	6,622	902	0
Dec-23	6,963	950	2	7,200	983	4	6,658	909	0
Jan-24	6,988	952	1	7,229	985	3	6,677	910	0
Feb-24	6,986	955	1	7,231	988	3	6,671	912	0
Mar-24	6,974	954	1	7,222	988	3	6,655	911	0
Apr-24	6,956	954	1	7,207	988	3	6,633	910	0
May-24	6,940	952	1	7,194	987	4	6,613	907	0
Jun-24	6,908	950	2	7,165	985	5	6,578	904	0
Jul-24	6,862	946	2	7,121	981	5	6,530	900	0
Aug-24	6,844	946	3	7,106	982	7	6,508	900	2
Sep-24	6,837	944	6	7,102	981	8	6,497	897	3
Oct-24	6,888	946	5	7,158	984	5	6,541	899	0
Nov-24	6,959	947	3	7,236	985	5	6,605	899	0
Dec-24	7,002	954	2	7,284	993	5	6,641	905	0
Jan-25	7,028	957	1	7,315	996	4	6,661	907	0
Feb-25	7,026	959	1	7,316	999	4	6,655	909	0
Mar-25	7,015	959	1	7,309	999	4	6,640	908	0
Apr-25	6,996	958	1	7,292	998	4	6,617	906	0
May-25	6,980	956	1	7,279	998	5	6,598	904	0
Jun-25	6,947	954	2	7,249	995	5	6,562	901	0
Jul-25	6,900	950	2	7,203	992	5	6,514	897	0
Aug-25	6,882	950	3	7,188	993	7	6,493	897	1
Sep-25	6,874	948	6	7,183	991	8	6,481	894	2
Oct-25	6,926	951	5	7,241	994	5	6,526	896	0
Nov-25	6,997	952	3	7,318	995	5	6,588	896	0
Dec-25	7,041	959	2	7,368	1,003	5	6,625	902	0
Jan-26	7,067	961	1	7,399	1,006	4	6,646	903	0
Feb-26	7,066	963	1	7,401	1,009	4	6,640	905	0
Mar-26	7,055	964	1	7,393	1,010	4	6,626	905	0
Apr-26	7,036	962	1	7,377	1,009	4	6,604	903	0
May-26	7,020	961	1	7,364	1,008	5	6,584	901	0
Jun-26	6,987	958	2	7,333	1,006	6	6,549	898	0

	La Grande - Expected Growth			La Grande - High Growth			La Grande - Low Growth		
	Residential Customers	Commercial Customers	Industrial Customers	Residential Customers	Commercial Customers	Industrial Customers	Residential Customers	Commercial Customers	Industrial Customers
Jul-26	6,939	955	2	7,286	1,003	6	6,500	894	0
Aug-26	6,921	955	3	7,270	1,003	8	6,479	894	1
Sep-26	6,913	953	6	7,265	1,001	9	6,467	891	2
Oct-26	6,964	955	5	7,322	1,004	6	6,511	893	0
Nov-26	7,036	956	3	7,402	1,006	6	6,574	893	0
Dec-26	7,079	963	2	7,450	1,014	6	6,610	899	0
Jan-27	7,106	965	1	7,482	1,016	5	6,631	901	0
Feb-27	7,105	968	1	7,485	1,020	5	6,626	903	0
Mar-27	7,094	968	1	7,477	1,020	5	6,612	902	0
Apr-27	7,075	967	1	7,460	1,019	5	6,590	900	0
May-27	7,059	965	1	7,447	1,018	6	6,571	898	0
Jun-27	7,025	963	2	7,414	1,016	6	6,535	895	0
Jul-27	6,978	959	2	7,368	1,013	6	6,487	892	0
Aug-27	6,959	959	3	7,352	1,013	8	6,466	891	0
Sep-27	6,951	957	6	7,347	1,011	9	6,454	889	1
Oct-27	7,002	959	5	7,404	1,014	6	6,497	890	0
Nov-27	7,074	960	3	7,483	1,016	6	6,560	891	0
Dec-27	7,118	967	2	7,533	1,024	6	6,597	897	0
Jan-28	7,144	970	1	7,565	1,027	5	6,617	898	0
Feb-28	7,144	972	1	7,568	1,030	5	6,613	900	0
Mar-28	7,132	972	1	7,559	1,030	5	6,598	899	0
Apr-28	7,114	971	1	7,543	1,030	5	6,577	898	0
May-28	7,097	969	1	7,529	1,028	6	6,557	896	0
Jun-28	7,064	967	2	7,497	1,026	7	6,523	893	0
Jul-28	7,016	963	2	7,450	1,023	7	6,474	889	0
Aug-28	6,998	964	3	7,434	1,024	9	6,454	889	0
Sep-28	6,989	961	6	7,428	1,022	10	6,441	886	1
Oct-28	7,041	964	5	7,486	1,025	7	6,485	888	0
Nov-28	7,112	965	3	7,565	1,026	7	6,547	888	0
Dec-28	7,156	972	2	7,616	1,034	7	6,583	894	0
Jan-29	7,183	974	1	7,648	1,037	6	6,604	895	0
Feb-29	7,182	977	1	7,650	1,040	6	6,599	897	0
Mar-29	7,171	977	1	7,642	1,041	6	6,585	897	0
Apr-29	7,153	975	1	7,626	1,040	6	6,565	895	0
May-29	7,136	974	1	7,612	1,039	7	6,545	893	0
Jun-29	7,103	971	2	7,580	1,037	7	6,511	890	0
Jul-29	7,055	968	2	7,532	1,033	7	6,463	887	0
Aug-29	7,036	968	3	7,515	1,034	9	6,441	886	0
Sep-29	7,028	966	6	7,511	1,032	10	6,430	883	0
Oct-29	7,079	968	6	7,569	1,035	7	6,472	885	0

	La Grande - Expected Growth			La Grande - High Growth			La Grande - Low Growth		
	Residential Customers	Commercial Customers	Industrial Customers	Residential Customers	Commercial Customers	Industrial Customers	Residential Customers	Commercial Customers	Industrial Customers
Nov-29	7,151	969	3	7,649	1,037	7	6,534	885	0
Dec-29	7,195	976	2	7,700	1,045	7	6,570	891	0
Jan-30	7,222	978	1	7,733	1,047	6	6,590	893	0
Feb-30	7,221	981	1	7,735	1,051	6	6,585	895	0
Mar-30	7,210	981	1	7,727	1,051	6	6,571	894	0
Apr-30	7,191	980	1	7,710	1,051	6	6,549	892	0
May-30	7,175	978	1	7,697	1,049	7	6,531	890	0
Jun-30	7,142	976	2	7,665	1,047	8	6,496	887	0
Jul-30	7,094	972	2	7,617	1,044	8	6,449	884	0
Aug-30	7,075	972	3	7,600	1,045	10	6,427	883	0
Sep-30	7,067	970	6	7,595	1,043	11	6,416	881	0
Oct-30	7,118	972	6	7,654	1,046	8	6,459	882	0
Nov-30	7,190	973	3	7,734	1,047	8	6,520	883	0
Dec-30	7,233	980	2	7,784	1,055	8	6,555	889	0
Jan-31	7,260	983	1	7,817	1,058	7	6,575	890	0
Feb-31	7,260	985	1	7,821	1,061	7	6,571	892	0
Mar-31	7,249	985	1	7,812	1,062	7	6,557	891	0
Apr-31	7,230	984	1	7,795	1,061	7	6,536	890	0
May-31	7,214	983	1	7,782	1,060	8	6,518	888	0
Jun-31	7,180	980	2	7,749	1,058	8	6,483	885	0
Jul-31	7,132	977	2	7,700	1,054	8	6,436	881	0
Aug-31	7,113	977	3	7,683	1,055	10	6,415	881	0
Sep-31	7,105	974	6	7,677	1,053	11	6,404	878	0
Oct-31	7,156	977	6	7,736	1,056	8	6,447	880	0
Nov-31	7,228	978	3	7,817	1,057	8	6,508	880	0
Dec-31	7,272	985	2	7,868	1,065	8	6,544	886	0
Jan-32	7,299	987	1	7,900	1,068	7	6,565	888	0
Feb-32	7,298	990	1	7,902	1,072	7	6,560	890	0
Mar-32	7,287	990	1	7,894	1,072	7	6,546	889	0
Apr-32	7,268	989	1	7,876	1,071	7	6,526	888	0
May-32	7,252	987	1	7,862	1,070	8	6,508	886	0
Jun-32	7,218	984	2	7,829	1,068	9	6,474	883	0
Jul-32	7,170	981	2	7,780	1,064	9	6,427	879	0
Aug-32	7,151	981	3	7,762	1,065	11	6,407	879	0
Sep-32	7,143	979	6	7,756	1,063	12	6,396	876	0
Oct-32	7,194	981	6	7,815	1,066	9	6,439	878	0
Nov-32	7,266	982	3	7,896	1,067	9	6,500	879	0
Dec-32	7,309	989	2	7,946	1,075	9	6,535	884	0
Jan-33	7,336	991	1	7,978	1,078	8	6,556	886	0
Feb-33	7,335	994	1	7,980	1,081	8	6,551	888	0

	La Grande - Expected Growth			La Grande - High Growth			La Grande - Low Growth		
	Residential Customers	Commercial Customers	Industrial Customers	Residential Customers	Commercial Customers	Industrial Customers	Residential Customers	Commercial Customers	Industrial Customers
Mar-33	7,324	994	1	7,971	1,082	8	6,538	887	0
Apr-33	7,306	993	1	7,955	1,081	8	6,519	886	0
May-33	7,289	991	1	7,939	1,080	9	6,500	884	0
Jun-33	7,255	989	2	7,905	1,077	9	6,466	881	0
Jul-33	7,207	985	2	7,856	1,074	9	6,421	878	0
Aug-33	7,188	985	3	7,838	1,075	11	6,401	878	0
Sep-33	7,180	983	6	7,831	1,072	12	6,391	875	0
Oct-33	7,231	986	6	7,890	1,075	9	6,434	877	0
Nov-33	7,303	986	3	7,971	1,077	9	6,495	877	0
Dec-33	7,346	994	2	8,020	1,085	9	6,530	883	0
Jan-34	7,373	996	1	8,052	1,087	8	6,551	885	0
Feb-34	7,372	998	1	8,054	1,091	8	6,548	887	0
Mar-34	7,361	998	1	8,045	1,091	8	6,535	886	0
Apr-34	7,342	997	1	8,026	1,090	8	6,515	885	0
May-34	7,325	996	1	8,011	1,089	9	6,497	883	0
Jun-34	7,292	993	2	7,977	1,086	10	6,465	880	0
Jul-34	7,243	990	2	7,926	1,083	10	6,419	877	0
Aug-34	7,224	990	3	7,908	1,083	12	6,400	877	0
Sep-34	7,216	987	6	7,901	1,081	13	6,390	874	0
Oct-34	7,267	990	6	7,960	1,084	10	6,432	876	0
Nov-34	7,339	991	3	8,041	1,086	10	6,493	877	0
Dec-34	7,382	998	2	8,091	1,094	10	6,528	883	0
Jan-35	7,409	1,000	1	8,123	1,096	9	6,550	884	0
Feb-35	7,408	1,003	1	8,124	1,100	9	6,546	886	0
Mar-35	7,397	1,003	1	8,115	1,100	9	6,533	886	0
Apr-35	7,378	1,002	1	8,097	1,099	9	6,514	884	0
May-35	7,361	1,000	1	8,080	1,098	10	6,496	883	0
Jun-35	7,327	997	2	8,046	1,095	10	6,463	880	0
Jul-35	7,279	994	2	7,995	1,092	10	6,419	877	0
Aug-35	7,260	994	3	7,976	1,092	12	6,400	876	0
Sep-35	7,251	992	6	7,968	1,090	13	6,390	874	0
Oct-35	7,302	994	6	8,026	1,093	10	6,433	876	0
Nov-35	7,374	995	3	8,107	1,094	10	6,494	876	0
Dec-35	7,417	1,002	2	8,157	1,102	10	6,530	882	0
Jan-36	7,444	1,004	1	8,188	1,104	9	6,551	884	0
Feb-36	7,443	1,007	1	8,189	1,108	9	6,548	886	0
Mar-36	7,431	1,007	1	8,178	1,108	9	6,536	886	0
Apr-36	7,413	1,006	1	8,160	1,107	9	6,518	884	0
May-36	7,396	1,004	1	8,144	1,106	10	6,500	882	0
Jun-36	7,362	1,002	2	8,108	1,103	11	6,468	880	0
Jul-36	7,314	998	2	8,057	1,100	11	6,425	877	0

	La Grande - Expected Growth			La Grande - High Growth			La Grande - Low Growth		
	Residential Customers	Commercial Customers	Industrial Customers	Residential Customers	Commercial Customers	Industrial Customers	Residential Customers	Commercial Customers	Industrial Customers
Aug-36	7,294	999	3	8,036	1,100	13	6,405	877	0
Sep-36	7,286	996	6	8,029	1,098	14	6,397	875	0
Oct-36	7,336	999	6	8,086	1,101	11	6,439	876	0
Nov-36	7,408	1,000	3	8,167	1,102	11	6,501	877	0
Dec-36	7,451	1,007	2	8,216	1,110	11	6,537	883	0
Jan-37	7,478	1,009	1	8,247	1,113	10	6,559	885	0
Feb-37	7,477	1,011	1	8,247	1,115	10	6,556	886	0
Mar-37	7,465	1,011	1	8,236	1,115	10	6,544	886	0
Apr-37	7,446	1,010	1	8,216	1,114	10	6,526	885	0
May-37	7,429	1,009	1	8,199	1,114	11	6,509	884	0
Jun-37	7,395	1,006	2	8,163	1,110	11	6,478	881	0
Jul-37	7,347	1,003	2	8,111	1,107	11	6,434	878	0
Aug-37	7,328	1,003	3	8,092	1,108	13	6,416	878	0
Sep-37	7,319	1,001	6	8,083	1,105	14	6,407	876	0
Oct-37	7,370	1,003	6	8,141	1,108	11	6,450	878	0
Nov-37	7,441	1,004	3	8,221	1,109	11	6,511	878	0
Dec-37	7,484	1,011	2	8,270	1,117	11	6,547	884	0
Jan-38	7,511	1,013	1	8,301	1,120	10	6,569	886	0
Feb-38	7,510	1,016	1	8,301	1,123	10	6,567	888	0
Mar-38	7,498	1,016	1	8,289	1,123	10	6,555	888	0
Apr-38	7,479	1,015	1	8,270	1,122	10	6,536	887	0
May-38	7,462	1,013	1	8,252	1,120	11	6,520	885	0
Jun-38	7,428	1,011	2	8,216	1,118	12	6,489	883	0
Jul-38	7,380	1,007	2	8,164	1,114	12	6,446	880	0
Aug-38	7,361	1,007	3	8,144	1,114	14	6,428	879	0
Sep-38	7,352	1,005	6	8,135	1,112	15	6,419	877	0
Oct-38	7,402	1,007	6	8,192	1,114	12	6,461	879	0
Nov-38	7,474	1,008	3	8,273	1,116	12	6,523	880	0
Dec-38	7,517	1,015	2	8,321	1,124	12	6,559	886	0
Jan-39	7,543	1,017	1	8,351	1,126	11	6,581	887	0
Feb-39	7,542	1,020	1	8,351	1,129	11	6,579	890	0
Mar-39	7,531	1,020	1	8,340	1,130	11	6,568	890	0
Apr-39	7,512	1,019	1	8,320	1,129	11	6,550	889	0
May-39	7,495	1,017	1	8,303	1,127	12	6,534	887	0
Jun-39	7,461	1,015	2	8,266	1,125	12	6,504	885	0
Jul-39	7,412	1,011	2	8,213	1,120	12	6,460	881	0
Aug-39	7,393	1,012	3	8,193	1,121	14	6,442	882	0
Sep-39	7,384	1,009	6	8,184	1,118	15	6,433	879	0
Oct-39	7,435	1,012	6	8,241	1,122	12	6,477	882	0
Nov-39	7,506	1,013	3	8,321	1,123	12	6,537	882	0
Dec-39	7,549	1,020	2	8,370	1,131	12	6,574	888	0

	La Grande - Expected Growth			La Grande - High Growth			La Grande - Low Growth		
	Residential Customers	Commercial Customers	Industrial Customers	Residential Customers	Commercial Customers	Industrial Customers	Residential Customers	Commercial Customers	Industrial Customers
Jan-40	7,575	1,022	1	8,400	1,133	11	6,595	890	0
Feb-40	7,574	1,024	1	8,400	1,136	11	6,593	891	0
Mar-40	7,563	1,024	1	8,388	1,136	11	6,583	891	0
Apr-40	7,544	1,023	1	8,368	1,135	11	6,565	890	0
May-40	7,527	1,022	1	8,350	1,134	12	6,549	889	0
Jun-40	7,493	1,019	2	8,314	1,131	13	6,519	886	0
Jul-40	7,444	1,016	2	8,260	1,127	13	6,475	884	0
Aug-40	7,425	1,016	3	8,240	1,128	15	6,458	884	0
Sep-40	7,416	1,014	6	8,231	1,125	16	6,449	882	0
Oct-40	7,467	1,016	6	8,288	1,128	13	6,492	883	0

APPENDIX 2.3: DEMAND COEFFICIENTS

	January	February	March	April	May	June	July	August	September	October	November	December
HEAT COEFFICIENTS												
WA Residential	0.010019	0.009649	0.008975	0.007554	0.004732	0.002420	0.001202	0.000985	0.003780	0.007364	0.009143	0.009637
WA Commercial	0.054204	0.055659	0.048708	0.039937	0.022778	0.016037	0.008276	0.010106	0.029505	0.038390	0.050902	0.053432
WA Industrial	0.134000	0.170731	0.134465	0.107716	0.078664	0.135746	0.099441	0.090432	0.416632	0.183366	0.183506	0.130699
ID Residential	0.009982	0.009734	0.009393	0.008056	0.005415	0.002854	0.001831	0.000407	0.003866	0.007696	0.009350	0.009867
ID Commercial	0.041681	0.040871	0.037664	0.028885	0.016144	0.014984	0.007763	0.012945	0.021341	0.027719	0.035806	0.039590
ID Industrial	0.134941	0.222589	0.109472	0.087363	0.062252	0.129064	0.098101	0.118899	0.366413	0.245318	0.246271	0.162023
Roseburg Residential	0.011149	0.012593	0.009735	0.009125	0.004685	0.003684	0.002130	0.007033	0.004377	0.008847	0.010957	0.011989
Roseburg Commercial	0.047161	0.055445	0.042659	0.040917	0.020398	0.021348	0.014584	0.057240	0.025390	0.033820	0.042781	0.049083
Roseburg Industrial	0.053693	0.057258	0.030779	0.111947	0.168205	0.287326	0.235004	0.387348	0.178307	0.143281	0.110984	0.073515
Medford Residential	0.010917	0.010712	0.009939	0.008005	0.005892	0.003467	0.000000	0.000000	0.003414	0.007311	0.009582	0.010439
Medford Commercial	0.041922	0.042473	0.036943	0.029781	0.020873	0.016028	0.000000	0.000000	0.025067	0.033347	0.039269	0.041024
Medford Industrial	0.021203	0.050709	0.031701	0.039025	0.038903	0.065874	0.000000	0.000000	0.261701	0.171043	0.102115	0.045663
La Grande Residential	0.009192	0.008803	0.007669	0.006581	0.005085	0.001944	0.000105	0.004633	0.000405	0.004864	0.007728	0.008849
La Grande Commercial	0.042772	0.041172	0.035023	0.027635	0.007455	0.003707	0.000243	0.028535	0.004161	0.019996	0.030626	0.038067
La Grande Industrial	0.000000	0.000000	0.000000	0.000000	1.623316	1.716208	7.876864	1.227047	2.524977	1.812518	0.100882	0.000000
Klamath Falls Residential	0.008363	0.008150	0.007709	0.006461	0.004610	0.002944	0.001342	0.000180	0.002579	0.005540	0.007408	0.008571
Klamath Falls Commercial	0.031363	0.031426	0.028144	0.022725	0.013172	0.009605	0.004353	0.003762	0.018697	0.021748	0.027153	0.031994
Klamath Falls Industrial	0.076215	0.109912	0.068231	0.083678	0.034930	0.060598	0.030497	0.151866	0.354761	0.223751	0.249885	0.149191
BASE COEFFICIENTS												
WA Residential	0.046575	0.046575	0.046575	0.046575	0.046575	0.046575	0.046575	0.046575	0.046575	0.046575	0.046575	0.046575
WA Commercial	0.381192	0.381192	0.381192	0.381192	0.381192	0.381192	0.381192	0.381192	0.381192	0.381192	0.381192	0.381192
WA Industrial	3.230733	3.230733	3.230733	3.230733	3.230733	3.230733	3.230733	3.230733	3.230733	3.230733	3.230733	3.230733
ID Residential	0.046699	0.046699	0.046699	0.046699	0.046699	0.046699	0.046699	0.046699	0.046699	0.046699	0.046699	0.046699
ID Commercial	0.378458	0.378458	0.378458	0.378458	0.378458	0.378458	0.378458	0.378458	0.378458	0.378458	0.378458	0.378458
ID Industrial	5.618589	5.618589	5.618589	5.618589	5.618589	5.618589	5.618589	5.618589	5.618589	5.618589	5.618589	5.618589
Roseburg Residential	0.040149	0.040149	0.040149	0.040149	0.040149	0.040149	0.040149	0.040149	0.040149	0.040149	0.040149	0.040149
Roseburg Commercial	0.317350	0.317350	0.317350	0.317350	0.317350	0.317350	0.317350	0.317350	0.317350	0.317350	0.317350	0.317350
Roseburg Industrial	2.811309	2.811309	2.811309	2.811309	2.811309	2.811309	2.811309	2.811309	2.811309	2.811309	2.811309	2.811309
Medford Residential	0.047701	0.047701	0.047701	0.047701	0.047701	0.047701	0.047701	0.047701	0.047701	0.047701	0.047701	0.047701
Medford Commercial	0.366506	0.366506	0.366506	0.366506	0.366506	0.366506	0.366506	0.366506	0.366506	0.366506	0.366506	0.366506
Medford Industrial	4.048021	4.048021	4.048021	4.048021	4.048021	4.048021	4.048021	4.048021	4.048021	4.048021	4.048021	4.048021
La Grande Residential	0.068987	0.068987	0.068987	0.068987	0.068987	0.068987	0.068987	0.068987	0.068987	0.068987	0.068987	0.068987
La Grande Commercial	0.386380	0.386380	0.386380	0.386380	0.386380	0.386380	0.386380	0.386380	0.386380	0.386380	0.386380	0.386380
La Grande Industrial	52.512335	52.512335	52.512335	52.512335	52.512335	52.512335	52.512335	52.512335	52.512335	52.512335	52.512335	52.512335
Klamath Falls Residential	0.034536	0.034536	0.034536	0.034536	0.034536	0.034536	0.034536	0.034536	0.034536	0.034536	0.034536	0.034536
Klamath Falls Commercial	0.229013	0.229013	0.229013	0.229013	0.229013	0.229013	0.229013	0.229013	0.229013	0.229013	0.229013	0.229013
Klamath Falls Industrial	4.059241	4.059241	4.059241	4.059241	4.059241	4.059241	4.059241	4.059241	4.059241	4.059241	4.059241	4.059241

APPENDIX 2.3: WA BASE COEFFICIENT CALCULATION

WA Average Actual Demand by Class (July & August)

Year	2015	2016	2017	2018	2019	Total Average
Average of Res Demand	6,625	7,149	6,574	7,128	7,213	6,938
Average of Com Demand	5,244	5,908	5,380	5,546	5,897	5,595
Average of Ind Demand	394	410	427	425	412	413

WA Average Customers by Class (July & August)

Year	2015	2016	2017	2018	2019	Total Average
Average of Res Demand	139,093	141,755	145,535	149,924	153,598	145,981
Average of Com Demand	14,173	14,456	14,551	14,721	14,863	14,553
Average of Ind Demand	135	130	133	130	129	131

Base Coefficients

(Actual Average Demand/Customer Count)

Res Base Usage	0.04752577
Com Base Usage	0.38447113
Ind Base Usage	3.15590337

APPENDIX 2.3: ID BASE COEFFICIENT CALCULATION

ID Average Actual Demand by Class (July & August)

Year	2015	2016	2017	2018	2019	Total Average
Average of Res Demand	2,979	3,361	3,140	3,583	3,739	3,361
Average of Com Demand	3,511	3,322	3,464	3,246	3,482	3,405
Average of Ind Demand	436	509	495	524	529	499

ID Average Customers by Class (July & August)

Year	2015	2016	2017	2018	2019	Total Average
Average of Res Demand	69,436	71,062	72,686	74,722	76,651	72,911
Average of Com Demand	8,613	8,751	8,881	8,958	9,092	8,859
Average of Ind Demand	100	97	93	92	91	94

Base Coefficients

(Actual Average Demand/Customer Count)

Res Base Usage	0.04609207
Com Base Usage	0.38436467
Ind Base Usage	5.28295751

APPENDIX 2.3: MEDFORD BASE COEFFICIENT CALCULATION

Medford Average Actual Demand by Class (July & August)

Year	2015	2016	2017	2018	2019	Total Average
Average of Res Demand	2,316	2,582	2,596	2,603	2,647	2,549
Average of Com Demand	2,303	2,487	2,487	2,481	2,633	2,478
Average of Ind Demand	60	60	68	49	58	59

Medford Average Customers by Class (July & August)

Year	2015	2016	2017	2018	2019	Total Average
Average of Res Demand	52,605	53,084	53,920	54,837	55,737	54,036
Average of Com Demand	6,596	6,796	6,850	6,906	6,987	6,827
Average of Ind Demand	15	15	15	14	14	15

Base Coefficients

(Actual Average Demand/Customer Count)

Res Base Usage	0.04716918
Com Base Usage	0.36305328
Ind Base Usage	4.03557818

APPENDIX 2.3: ROSEBURG BASE COEFFICIENT CALCULATION

Roseburg Average Actual Demand by Class (July & August)

Year	2015	2016	2017	2018	2019	Total Average
Average of Res Demand	430	466	486	474	667	505
Average of Com Demand	557	557	628	597	817	631
Average of Ind Demand	4	4	5	3	5	4

Roseburg Average Customers by Class (July & August)

Year	2015	2016	2017	2018	2019	Total Average
Average of Res Demand	13,227	13,242	13,337	13,518	13,685	13,402
Average of Com Demand	2,130	2,156	2,141	2,146	2,150	2,144
Average of Ind Demand	2	2	2	1	2	2

Base Coefficients

(Actual Average Demand/Customer Count)

Res Base Usage	0.03765259
Com Base Usage	0.29442810
Ind Base Usage	2.45310434

APPENDIX 2.3: KLAMATH FALLS BASE COEFFICIENT CALCULATION

Klamath Falls Average Actual Demand by Class (July & August)

Year	2015	2016	2017	2018	2019	Total Average
Average of Res Demand	531	397	458	495	562	488
Average of Com Demand	484	308	361	401	448	400
Average of Ind Demand	30	19	26	28	27	26

Klamath Falls Average Customers by Class (July & August)

Year	2015	2016	2017	2018	2019	Total Average
Average of Res Demand	14,106	14,206	14,397	14,619	14,823	14,430
Average of Com Demand	1,667	1,722	1,762	1,753	1,770	1,734
Average of Ind Demand	7	7	7	7	6	7

Base Coefficients

(Actual Average Demand/Customer Count)

Res Base Usage	0.03384355
Com Base Usage	0.23084798
Ind Base Usage	3.84363453

APPENDIX 2.3: LA GRANDE BASE COEFFICIENT CALCULATION

La Grande Average Actual Demand by Class (July & August)

Year	2015	2016	2017	2018	2019	Total Average
Average of Res Demand	554	497	439	478	457	485
Average of Com Demand	441	377	338	367	359	376
Average of Ind Demand	122	192	202	86	159	152

La Grande Average Customers by Class (July & August)

Year	2015	2016	2017	2018	2019	Total Average
Average of Res Demand	6,547	6,529	6,565	6,660	6,695	6,599
Average of Com Demand	897	919	914	916	923	914
Average of Ind Demand	4	3	3	3	4	3

Base Coefficients

(Actual Average Demand/Customer Count)

Res Base Usage	0.07350633
Com Base Usage	0.41177227
Ind Base Usage	50.71916892

APPENDIX 2.4: HEATING DEGREE DAY DATA MONTHLY TABLES

Temperature Pattern WA/ID													Annual Total
Gas Year	Nov	Dec	Jan	Feb	Mar	Apr	May	Jun	Jul	Aug	Sep	Oct	
2020-2021	887	1,152	1,107	946	791	561	297	139	20	24	182	550	6,656
2021-2022	892	1,149	1,115	943	793	559	306	140	22	24	178	547	6,667
2022-2023	887	1,140	1,110	947	789	561	298	140	21	23	179	545	6,640
2023-2024	879	1,141	1,119	945	791	556	306	140	21	24	184	544	6,651
2024-2025	886	1,148	1,115	944	792	560	304	137	21	24	180	548	6,658
2025-2026	884	1,145	1,118	945	791	555	299	141	21	24	181	544	6,649
2026-2027	891	1,141	1,114	942	793	550	301	139	21	23	181	549	6,645
2027-2028	881	1,141	1,113	947	795	558	301	140	21	24	181	550	6,652
2028-2029	889	1,147	1,112	948	789	555	301	141	21	24	180	549	6,656
2029-2030	893	1,148	1,112	944	797	555	299	140	22	24	181	548	6,664
2030-2031	887	1,151	1,119	948	794	557	301	138	21	24	178	547	6,662
2031-2032	883	1,143	1,108	945	794	558	299	141	21	24	178	546	6,640
2032-2033	890	1,147	1,110	951	793	560	302	143	22	24	182	550	6,674
2033-2034	891	1,139	1,111	945	794	553	305	140	21	24	181	549	6,654
2034-2035	894	1,146	1,111	947	791	558	298	140	20	24	178	547	6,653
2035-2036	885	1,141	1,110	940	790	556	300	141	20	24	180	546	6,632
2036-2037	884	1,147	1,117	948	795	563	300	142	21	24	177	548	6,665
2037-2038	887	1,141	1,111	945	794	559	300	141	20	24	177	549	6,648
2038-2039	883	1,146	1,112	949	791	554	306	140	22	24	180	544	6,650
2039-2040	889	1,146	1,110	944	793	559	299	141	22	23	180	547	6,654

Temperature Pattern Klamath Falls													Annual
Gas Year	Nov	Dec	Jan	Feb	Mar	Apr	May	Jun	Jul	Aug	Sep	Oct	Total
2020-2021	875	1,084	1,053	870	809	660	431	204	43	58	236	567	6,889
2021-2022	868	1,081	1,047	867	817	656	430	210	42	59	240	565	6,882
2022-2023	872	1,079	1,055	875	811	658	431	206	42	57	237	564	6,887
2023-2024	872	1,078	1,050	870	813	653	431	209	42	57	237	564	6,877
2024-2025	871	1,082	1,055	869	815	661	428	205	43	58	234	563	6,883
2025-2026	872	1,075	1,044	865	814	658	430	207	41	58	235	568	6,868
2026-2027	871	1,080	1,057	868	815	656	426	206	41	58	233	570	6,882
2027-2028	871	1,081	1,050	871	813	653	429	207	44	58	232	567	6,876
2028-2029	874	1,077	1,062	869	813	650	425	209	42	57	234	569	6,881
2029-2030	871	1,080	1,052	868	814	659	425	206	44	58	234	571	6,882
2030-2031	868	1,084	1,051	864	818	654	427	205	43	58	235	564	6,872
2031-2032	869	1,081	1,054	869	812	653	424	203	42	57	236	565	6,867
2032-2033	875	1,082	1,053	868	811	656	433	205	43	57	235	569	6,886
2033-2034	871	1,082	1,055	867	812	657	428	205	43	57	233	568	6,879
2034-2035	878	1,081	1,053	867	818	654	428	205	43	56	235	567	6,886
2035-2036	870	1,080	1,050	870	814	655	428	209	42	58	233	569	6,877
2036-2037	869	1,078	1,056	869	813	656	427	203	43	58	237	566	6,876
2037-2038	874	1,077	1,059	874	814	655	427	207	40	58	235	567	6,887
2038-2039	867	1,082	1,053	870	815	654	429	208	42	56	234	568	6,879
2039-2040	871	1,082	1,052	867	814	654	435	209	42	57	238	566	6,886

Temperature Pattern Medford													Annual
Gas Year	Nov	Dec	Jan	Feb	Mar	Apr	May	Jun	Jul	Aug	Sep	Oct	Total
2020-2021	605	805	775	604	526	379	177	51	2	3	55	291	4,273
2021-2022	608	808	776	604	533	378	179	53	2	3	54	294	4,294
2022-2023	613	803	776	605	530	372	178	52	2	3	55	290	4,280
2023-2024	602	805	771	607	530	378	180	52	2	3	55	291	4,275
2024-2025	608	804	778	607	523	376	186	54	2	3	54	291	4,287
2025-2026	611	802	776	606	528	377	181	52	2	3	58	293	4,288
2026-2027	607	802	778	609	530	374	179	53	2	3	56	293	4,286
2027-2028	603	799	774	603	529	376	183	52	2	3	56	293	4,272
2028-2029	607	806	776	608	523	375	181	53	2	3	55	295	4,284
2029-2030	609	804	777	606	524	374	182	52	2	3	55	293	4,281
2030-2031	610	799	774	606	533	375	181	52	2	3	58	294	4,287
2031-2032	605	806	775	605	529	373	182	53	2	3	55	295	4,282
2032-2033	605	804	776	607	529	378	182	53	2	3	56	293	4,285
2033-2034	604	803	773	608	525	374	182	54	2	3	55	294	4,277
2034-2035	610	801	776	606	532	374	183	51	2	3	57	291	4,286
2035-2036	609	804	773	604	527	375	180	52	2	3	56	292	4,277
2036-2037	605	800	777	604	530	373	180	51	2	3	56	290	4,271
2037-2038	603	804	776	602	528	370	181	53	2	3	57	293	4,272
2038-2039	605	810	776	601	527	374	179	52	2	3	57	295	4,280
2039-2040	606	807	776	603	532	375	180	52	2	3	56	288	4,281

Temperature Pattern Roseburg													Annual
Gas Year	Nov	Dec	Jan	Feb	Mar	Apr	May	Jun	Jul	Aug	Sep	Oct	Total
2020-2021	539	702	684	559	499	376	204	77	4	5	61	285	3,994
2021-2022	540	706	685	562	506	377	200	79	4	4	62	283	4,009
2022-2023	545	700	686	560	503	379	200	77	4	5	61	281	4,000
2023-2024	537	701	678	564	502	376	204	78	4	5	62	284	3,996
2024-2025	542	703	684	562	496	375	201	78	4	5	62	289	4,001
2025-2026	542	700	685	561	500	377	203	77	4	5	62	284	4,001
2026-2027	540	700	685	564	504	375	203	79	5	5	61	280	3,999
2027-2028	536	698	682	558	502	375	201	76	4	4	63	280	3,979
2028-2029	540	702	684	564	496	374	203	78	4	5	63	285	3,997
2029-2030	542	702	686	561	498	377	205	76	4	5	61	283	4,000
2030-2031	543	700	684	562	505	379	204	78	4	5	61	284	4,010
2031-2032	540	704	682	560	501	379	204	78	4	4	62	286	4,004
2032-2033	541	702	685	562	501	374	200	75	4	5	62	285	3,996
2033-2034	537	701	681	563	497	376	200	77	4	5	63	282	3,986
2034-2035	542	699	682	561	506	380	199	79	5	5	63	284	4,003
2035-2036	543	703	682	559	499	372	204	78	4	5	60	287	3,996
2036-2037	537	699	687	560	504	379	199	77	5	5	61	286	3,998
2037-2038	538	702	683	558	500	376	204	77	4	5	61	285	3,992
2038-2039	537	708	685	556	499	374	201	78	4	5	62	282	3,990
2039-2040	539	706	685	559	505	376	206	78	4	5	62	282	4,007

Temperature Pattern La Grande													Annual
Gas Year	Nov	Dec	Jan	Feb	Mar	Apr	May	Jun	Jul	Aug	Sep	Oct	Total
2020-2021	793	1,041	1,029	829	724	556	336	150	23	37	198	524	6,240
2021-2022	791	1,038	1,027	828	727	554	335	150	23	36	198	523	6,229
2022-2023	794	1,041	1,015	825	727	551	338	149	22	37	199	523	6,221
2023-2024	791	1,038	1,025	828	726	552	337	151	23	38	199	528	6,235
2024-2025	797	1,040	1,022	829	728	553	336	149	23	37	201	521	6,236
2025-2026	791	1,045	1,016	829	727	552	336	147	23	38	199	522	6,224
2026-2027	795	1,041	1,020	827	726	559	337	150	23	37	200	519	6,235
2027-2028	790	1,045	1,025	826	728	553	337	151	23	37	197	525	6,237
2028-2029	795	1,038	1,025	825	728	556	334	148	22	36	199	518	6,227
2029-2030	798	1,040	1,026	830	730	553	334	151	23	37	198	530	6,250
2030-2031	793	1,046	1,020	827	729	553	332	152	22	37	199	521	6,231
2031-2032	790	1,038	1,029	827	724	551	341	150	24	36	201	516	6,228
2032-2033	799	1,039	1,017	826	723	555	338	149	24	38	199	526	6,235
2033-2034	790	1,044	1,018	826	723	554	337	148	24	37	197	527	6,223
2034-2035	794	1,040	1,028	828	724	555	334	150	23	36	198	521	6,231
2035-2036	793	1,042	1,031	827	725	554	334	150	24	37	199	524	6,239
2036-2037	789	1,043	1,018	831	724	553	338	149	23	37	198	524	6,226
2037-2038	797	1,040	1,024	829	723	557	335	149	22	36	200	521	6,233
2038-2039	797	1,041	1,025	827	729	555	339	152	24	37	195	523	6,244
2039-2040	790	1,042	1,025	830	720	554	336	151	25	37	200	521	6,232

APPENDIX 2.4: AVERAGE HEATING DEGREE DAILY MONTH BY AREA

Temperature Pattern		WA/ID										
Day	Jan	Feb	Mar	Apr	May	Jun	Jul	Aug	Sep	Oct	Nov	Dec
1	39	35	31	22	15	2	0	0	0	10	25	35
2	39	34	31	23	13	5	0	0	0	12	24	34
3	39	34	30	22	13	4	0	0	1	14	25	35
4	36	33	29	22	12	4	0	0	1	14	25	35
5	37	33	27	22	13	4	0	0	2	14	26	36
6	36	33	27	20	14	5	0	0	3	13	26	37
7	35	34	27	19	12	4	0	0	2	13	26	38
8	34	34	28	19	11	6	0	0	3	15	26	38
9	33	34	28	20	12	7	0	0	4	16	27	38
10	35	34	27	19	12	7	0	0	3	17	28	36
11	37	34	25	19	9	7	0	0	2	18	29	36
12	36	31	24	18	9	5	0	0	1	18	28	35
13	36	32	24	19	10	4	0	0	2	16	28	35
14	36	33	24	21	7	6	0	0	2	15	29	36
15	39	32	24	22	7	5	0	0	2	17	28	37
16	38	31	24	19	6	4	0	0	5	15	27	37
17	36	32	26	19	8	4	0	0	6	15	28	37
18	34	33	25	18	8	4	0	0	6	16	29	36
19	35	33	25	17	7	4	0	0	7	16	29	37
20	35	33	24	15	10	3	0	0	9	16	30	36
21	35	32	24	14	8	1	0	0	10	18	31	35
22	35	32	24	16	8	0	0	0	8	17	32	37
23	34	34	24	17	7	1	0	0	7	20	32	37
24	34	35	24	16	7	1	0	0	6	20	33	36
25	33	35	24	16	7	0	0	0	5	21	33	37
26	34	35	24	15	7	0	0	0	6	22	32	37
27	35	32	23	14	6	0	0	0	6	23	34	37
28	35	32	23	16	6	0	0	0	7	23	35	36
29	34	28	22	17	6	0	0	0	8	24	36	38
30	34		20	15	5	0	0	0	9	25	35	39
31	34		22		4		0	0		24		40
Total	1,102	957	784	551	279	97	0	0	133	537	876	1,133

Temperature Pattern		Medford										
Day	Jan	Feb	Mar	Apr	May	Jun	Jul	Aug	Sep	Oct	Nov	Dec
1	27	24	20	15	8	0	0	0	0	4	15	25
2	26	22	20	14	6	0	0	0	0	6	16	24
3	28	21	20	15	6	0	0	0	0	6	16	25
4	26	22	19	13	6	0	0	0	0	6	17	25
5	25	22	19	14	8	0	0	0	0	7	17	26
6	26	22	19	12	7	0	0	0	0	5	16	25
7	24	21	19	13	6	0	0	0	0	5	17	27
8	23	22	19	13	6	1	0	0	0	6	18	25
9	24	21	18	13	7	1	0	0	0	8	20	24
10	25	22	17	12	6	2	0	0	0	9	18	26
11	24	21	16	12	6	1	0	0	0	10	19	27
12	24	21	16	13	5	0	0	0	0	10	18	26
13	26	21	16	14	3	0	0	0	0	7	18	24
14	27	21	17	16	2	0	0	0	0	7	18	25
15	26	20	16	17	3	0	0	0	0	8	19	27
16	26	20	17	14	4	0	0	0	0	7	20	27
17	26	19	17	13	4	0	0	0	0	8	21	27
18	25	21	16	13	4	0	0	0	0	8	22	26
19	24	22	15	12	4	0	0	0	0	8	20	24
20	26	21	15	11	5	0	0	0	0	10	21	24
21	25	20	15	11	5	0	0	0	0	11	22	24
22	24	22	16	9	4	0	0	0	1	10	22	25
23	24	23	17	10	3	0	0	0	1	11	23	25
24	23	20	15	10	2	0	0	0	0	12	23	26
25	23	21	18	9	3	0	0	0	0	13	22	26
26	23	22	17	8	2	0	0	0	0	13	23	27
27	25	21	16	9	3	0	0	0	0	14	24	26
28	24	21	15	10	2	0	0	0	0	13	23	26
29	23	21	14	10	1	0	0	0	1	14	25	26
30	24		14	9	0	0	0	0	2	13	25	26
31	25		14		0		0	0		14		27
Total	771	617	522	364	131	5	0	0	5	283	598	793

Temperature Pattern		La Grande										
Day	Jan	Feb	Mar	Apr	May	Jun	Jul	Aug	Sep	Oct	Nov	Dec
1	38	32	28	21	16	4	0	0	1	11	24	30
2	36	31	26	22	14	5	0	0	2	13	22	32
3	36	30	28	21	14	5	0	0	2	13	23	32
4	34	28	27	20	13	4	0	0	2	15	22	33
5	35	29	24	21	13	5	0	0	2	16	23	34
6	34	29	25	18	15	6	0	0	3	14	22	33
7	31	30	25	18	13	5	0	0	3	12	23	35
8	29	29	26	18	12	6	0	0	4	14	22	34
9	29	30	24	19	14	7	0	0	5	15	24	34
10	32	30	24	18	14	9	0	0	4	17	24	31
11	32	29	24	18	11	8	0	0	5	18	26	32
12	33	28	22	18	11	6	0	0	3	18	25	32
13	32	29	21	18	10	5	0	0	3	15	26	30
14	33	28	22	21	8	6	0	0	4	15	26	32
15	36	28	22	21	8	4	0	0	3	15	26	32
16	34	28	22	20	9	5	0	0	6	14	26	35
17	33	28	24	18	9	4	0	0	6	14	26	36
18	32	29	23	19	8	6	0	0	7	15	27	35
19	30	30	23	17	9	5	0	0	7	14	25	33
20	31	29	22	15	11	3	0	0	9	15	26	32
21	32	29	23	16	11	3	0	0	10	18	28	31
22	33	28	22	16	10	2	0	0	10	17	28	32
23	32	30	23	16	9	2	0	0	9	18	29	34
24	31	30	22	18	8	2	0	1	8	20	30	34
25	30	30	22	16	9	1	0	0	9	19	30	35
26	32	30	24	16	8	0	0	0	8	21	29	35
27	33	29	23	14	7	0	0	0	7	21	30	34
28	33	28	21	17	8	0	0	0	8	20	32	32
29	32	26	20	18	7	0	0	0	8	22	32	33
30	30		20	17	6	0	0	0	9	22	32	37
31	31		20		6		0	1		22		38
Total	1,009	844	722	545	321	118	0	2	167	513	788	1,032

Temperature Pattern		Klamath Falls										
Day	Jan	Feb	Mar	Apr	May	Jun	Jul	Aug	Sep	Oct	Nov	Dec
1	37	32	30	24	18	7	0	0	3	14	25	32
2	36	31	30	25	16	8	0	0	3	15	26	33
3	36	29	30	24	15	7	0	0	3	16	26	34
4	36	31	29	23	15	7	0	0	4	17	26	34
5	36	31	28	24	16	8	0	0	6	16	26	34
6	35	30	27	22	17	8	0	0	5	14	25	33
7	32	30	28	22	15	9	0	0	5	14	26	36
8	31	31	27	22	15	9	1	0	5	15	27	34
9	33	30	27	23	17	10	0	0	6	17	29	33
10	33	31	27	22	16	11	0	0	6	18	28	34
11	34	30	25	22	15	10	0	0	4	20	28	35
12	34	29	25	22	14	8	0	0	3	19	26	34
13	35	28	25	23	13	8	0	0	5	16	27	33
14	35	29	25	26	11	7	0	0	6	15	26	35
15	35	29	24	26	11	6	0	0	8	16	27	37
16	34	30	25	24	13	7	0	0	11	16	27	36
17	34	30	26	22	13	7	0	0	10	17	28	38
18	33	32	25	23	13	7	0	0	9	17	28	35
19	33	33	24	21	13	6	0	0	10	18	27	33
20	33	31	24	20	14	6	0	0	10	19	27	32
21	34	30	23	20	13	4	0	0	10	20	29	33
22	34	31	25	19	13	4	0	1	11	18	30	35
23	33	32	26	19	12	3	0	2	11	20	31	34
24	33	30	25	19	11	4	0	1	9	20	33	35
25	32	30	26	19	12	3	0	1	10	21	32	35
26	32	32	26	19	11	2	0	2	9	21	33	37
27	33	31	25	18	11	0	0	1	8	23	34	35
28	33	31	24	20	12	0	0	1	8	22	35	34
29	32	33	24	20	10	0	0	0	10	23	35	35
30	32		23	19	9	0	0	3	12	23	34	37
31	34		23		7		0	4		24		38
Total	1,047	887	801	652	411	176	1	16	220	564	861	1,073

Temperature Pattern		Roseburg										
Day	Jan	Feb	Mar	Apr	May	Jun	Jul	Aug	Sep	Oct	Nov	Dec
1	24	20	19	15	8	2	0	0	0	5	14	21
2	24	19	18	15	7	1	0	0	0	7	13	21
3	24	20	19	15	8	1	0	0	0	7	14	21
4	23	19	18	13	7	1	0	0	0	7	15	22
5	22	19	18	14	9	2	0	0	0	6	14	22
6	22	19	18	12	8	1	0	0	0	5	14	23
7	20	20	18	12	7	1	0	0	0	5	17	25
8	20	20	17	13	7	2	0	0	0	6	17	23
9	21	20	15	13	8	3	0	0	0	8	17	22
10	21	20	16	13	7	5	0	0	0	9	17	23
11	22	19	15	12	7	2	0	0	0	10	17	22
12	22	19	15	13	6	1	0	0	0	10	15	21
13	23	20	15	13	5	1	0	0	0	7	15	22
14	24	20	15	16	4	2	0	0	0	7	16	24
15	24	18	15	16	5	1	0	0	0	8	16	24
16	22	20	16	14	5	1	0	0	0	7	17	23
17	22	18	17	12	4	0	0	0	1	8	17	24
18	21	20	15	11	5	1	0	0	1	8	19	24
19	21	21	15	11	5	0	0	0	1	7	16	22
20	22	21	15	11	6	0	0	0	1	9	20	20
21	21	19	16	11	6	0	0	0	2	9	20	21
22	22	20	16	10	5	0	0	0	2	8	20	22
23	20	21	16	11	4	0	0	0	2	11	21	20
24	21	20	15	10	4	0	0	0	0	12	20	22
25	21	20	16	9	5	0	0	0	1	12	21	23
26	22	21	16	10	3	0	0	0	0	12	21	24
27	22	20	15	10	4	0	0	0	0	14	22	22
28	21	20	15	10	5	0	0	0	1	12	22	22
29	20	20	14	11	3	0	0	0	3	13	22	23
30	20		14	10	2	0	0	0	3	13	22	24
31	21		14		1		0	0		13		24
Total	675	573	496	366	170	28	0	0	18	275	531	696

APPENDIX 2.5: DEMAND SENSITIVITIES SUMMARY OF ASSUMPTIONS – DEMAND SCENARIOS

Influence Type	Sensitivity	Customer Growth Rate	Use per Customer	Weather	Demand Side Management	Prices	Elasticity	First Year System Unserved	Location Unserved						
DEMAND INFLUENCING - DIRECT	Reference	Reference	3 Year Historical	20 Year Average	None	Expected	None	-							
	Reference Plus Peak	Reference		Planning Standard				2035	Washington						
	Low Cust	Low Growth							-						
	High Cust	High Growth							2029	Washington					
	Alternate Weather Standard							Coldest in 20yrs	2035	Washington					
	DSM							20 Year Average	-						
	Peak plus DSM								2036	Washington					
	80% below 1990 emissions								2035	Washington					
	2 Year use per customer Alternate			2 Year Historical					2035	Washington					
	5 Year use per customer Alternate			5 Year Historical					2035	Washington					
	JP Outage Only (0% capacity)	Reference	3 Year Historical	Planning Standard	None	Expected	None	2021	Washington						
	AECO Outage Only (0% capacity)							2020	WA, ID						
	Sumas Outage Only (0% capacity)							2020	Medford						
	Rockies Outage Only (0% capacity)							2020	La Grande						
	JP Outage Only (50% capacity)							2021	Washington						
	AECO Outage Only (50% capacity)							2026	Washington						
	Sumas Outage Only (50% capacity)							2025	Washington						
	Rockies Outage Only (50% capacity)							2025	La Grande						
	NWP Outage (0% capacity)							2020	WA, ID, La Grande						
	GTN Outage (0% capacity)							2020	WA, ID, Klamath Falls						
	NWP Outage (50% capacity)							2020	WA, La Grande						
	GTN Outage (50% capacity)							2026	Washington						
	PRICE INFLUENCING - INDIRECT							Expected Prices		3 Year Historical				Expected	-
Low Prices												Low	-		
High Prices												High	-		
Carbon Cost - High (SCC 95% at 3%)													-		
Carbon Cost - Expected (SCC 2.5% (WA) & Cap&Red (OR))													-		
Carbon Cost - Low \$0												-			
EMISSIONS INFLUENCING	High Upstream Emissions 2.47% leakage (EDF study)											Expected	Expected	-	
	Expected Upstream Emissions (0.79% leakage)											-			
	No Upstream Emissions											-			
	Expected Global Warming Potential (20 Years)											-			
												-			
						-									

APPENDIX 2.5: DEMAND SCENARIOS PROPOSED SCENARIOS

Proposed Scenarios INPUT ASSUMPTIONS	Expected Case	Average Case	Low Growth & High Prices	Electrification - Carbon Reduction	High Growth & Low Prices
Customer Growth Rate	Reference Case Cust Growth Rates		Low Growth Rate	Reference Case Cust Growth Rates	High Growth Rate
Use per Customer	3 yr + Price Elasticity				
Demand Side Management	Expected Case CPA		High Prices DSM	Low Prices DSM	
Weather Planning Standard	99% probability of coldest in 30 years	20 year average	99% probability of coldest in 30 years		
GWP	100-Year GWP				
Prices	Expected		High	Low	
Price curve					
Carbon Legislation (\$/Metric Ton)	SCC @ 2.5% WA; Cap and Trade forecast - OR; NO Carbon adder in ID		Carbon Cost - High (SCC 95% at 3%)	SCC @ 2.5% WA; Cap and Trade forecast - OR; NO Carbon adder in ID	\$0
RESULTS					
First Gas Year Unserved					
Washington	N/A	N/A	N/A	N/A	2036
Idaho	N/A	N/A	N/A	N/A	2036
Medford	N/A	N/A	N/A	N/A	N/A
Roseburg	N/A	N/A	N/A	N/A	N/A
Klamath	N/A	N/A	N/A	N/A	N/A
La Grande	N/A	N/A	N/A	N/A	2040
Scenario Summary					
	Most aggressive peak planning case utilizing Average Case assumptions as a starting point and layering in peak day 99% probability. The likelihood of occurrence is low.	Case most representative of our average (budget, PGA, rate case) planning criteria.	Stagnant growth assumptions in order to evaluate if a shortage does occur. Not likely to occur.	Reduction of the use of natural gas to 80% below 1990 targets in OR and WA by 2050. The case assumes the overall reduction is an average goal before applying figures like elasticity and DSM.	Aggressive growth assumptions in order to evaluate when our earliest resource shortage could occur. Not likely to occur.
Risk Assessment					
Higher or lower customer growth rates, which are heavily based on economic recovery. Higher or lower growth rates will lead to accelerated or delayed unserved demand. Looking at various growth assumptions off the Expected Case allows us to capture the risk in terms of the change in demand linked to customer growth.					
Higher or lower use per customer will also lead to accelerated or delayed unserved demand. Use per customer can differ in many ways. Direct use per customer influencers, such as demand side management, NGV/CNG usage, and derivation of the use per customer starting point (i.e. one year, three year, etc.). Again, varying these assumptions under our forecasting methodology allows us to quantify the change each assumption has to our forecast.					
Weather volatility and predictability are a key risk. As the most correlated direct demand influencer, varying weather assumptions is key to understanding the weather related risks.					
Indirect influencers including elasticity and price are also important assumptions. The two go hand in hand, as price changes it will influence how much customers consume. If forecasted prices remain relatively stable over the planning horizon, our current elasticity assumption will not provide much decreased usage. However, price adders or an overall steepening of the price curve will trigger a greater decline in usage due to the price elastic response. The magnitude of the elasticity adjustment is also important. We are using a long run elasticity factor as calculated by the AGA. We continue to evaluate this assumption and are looking to update the study as part of our Action Plan.					

APPENDIX 2.6: DEMAND FORECAST SENSITIVITIES AND SCENARIOS DESCRIPTIONS

DEFINITIONS

DYNAMIC DEMAND METHODOLOGY – Avista’s demand forecasting approach wherein we 1) identify key demand drivers behind natural gas consumption, 2) perform sensitivity analysis on each demand driver, and 3) combine demand drivers under various scenarios to develop alternative potential outcomes for forecasted demand.

DEMAND INFLUENCING FACTORS – Factors that directly influence the volume of natural gas consumed by our core customers.

PRICE INFLUENCING FACTORS – Factors that, through price elasticity response, indirectly influence the volume of natural gas consumed by our core customers.

REFERENCE CASE – A baseline point of reference that captures the basic inputs for determining a demand forecast in SENDOUT® which includes number of customers, use per customer, average daily weather temperatures and expected natural gas prices.

SENSITIVITIES – Focused analysis of a specific natural gas demand driver and its impact on forecasted demand relative to the Reference Case when underlying input assumptions are modified.

SCENARIOS – Combination of natural gas demand drivers that make up a demand forecast.

Avista evaluates each sensitivities impact.

SENSITIVITIES

The following Sensitivities were performed on identified demand drivers against the reference case for consideration in Scenario development. Note that Sensitivity assumptions reflect incremental adjustments we estimate are not captured in the underlying reference case forecast.

Following are the Demand Influencing (Direct) Sensitivities we evaluated:

REFERENCE CASE – This benchmark case uses expected customer growth rates, the most recent three years of actual use per customer per heating degree day data, average daily temperature (HDDs) in the most recent 20 years in each region, no DSM, expected prices, and no elasticity of demand.

REFERENCE CASE PLUS PEAK – Same assumptions as in the Reference Case with an adjustment made to normal weather to incorporate peak weather conditions. The peak weather data being the coldest day on record for each weather area.

LOW & HIGH CUSTOMER GROWTH – Same assumptions as in Reference Case Plus Peak with an adjustment made to customer growth rates as discussed in detail in Appendix 2.1: Economic Outlook and Customer Count Forecast.

ALTERNATE WEATHER STANDARD (COLDEST DAY 20 YRS) – Same assumptions as in the Reference Case with an adjustment made to normal weather to incorporate peak day weather conditions. The peak day weather data reflecting the coldest average daily temperature (HDDs) experienced in the most recent 20 years in each region.

DSM – Same assumptions as in Reference Case with the inclusion of Washington and Idaho DSM potential identified by the Conservation Potential Assessment provided by Applied Energy Group and Oregon DSM potential provided by Energy Trust of Oregon. See Appendix 3.1 for full assessment reports.

PEAK PLUS DSM – Same assumptions as in Reference Case Plus Peak with the inclusion of Washington and Idaho DSM potential identified by the Conservation Potential Assessment provided by Applied Energy Group and Oregon DSM potential provided by Energy Trust of Oregon. See Appendix 3.1 for full assessment reports.

80% BELOW 1990 EMISSIONS REFERENCE CASE – Reference Case Plus Peak assumptions including reduction in Oregon and Washington consumption to 80% below 1990 emission levels by 2050. The case shows the overall risk of a scenario with the overall goal of reducing natural gas emissions but does not consider what methods will be used to get to these levels or their costs.

ALTERNATE HISTORICAL 2-YEAR USE PER CUSTOMER – Reference Case Plus Peak use per customer was based upon three years of actual use per customer per heating degree day data. Same assumptions as in Reference Case Plus Peak with an adjustment made to use two years of historical use per customer per heating degree day data.

ALTERNATE HISTORICAL 5-YEAR USE PER CUSTOMER – Reference Case Plus Peak use per customer was based upon three years of actual use per customer per heating degree day data. Same assumptions as in Reference Case Plus Peak with an adjustment made to use five years of historical use per customer per heating degree day data.

JP OUTAGE AT 50% CAPACITY – Same assumptions as in Reference Case Plus Peak with available transportation from Jackson Prairie storage field reduced to 50% of expected capacity.

AECO OUTAGE AT 50% CAPACITY – Same assumptions as in Reference Case Plus Peak with available transportation from AECO reduced to 50% of expected capacity.

SUMAS OUTAGE AT 50% CAPACITY – Same assumptions as in Reference Case Plus Peak with available transportation from Sumas reduced to 50% of expected capacity.

ROCKIES OUTAGE AT 50% CAPACITY – Same assumptions as in Reference Case Plus Peak with available transportation from Rockies reduced to 50% of expected capacity.

GTN OUTAGE AT 50% CAPACITY – Same assumptions as in Reference Case Plus Peak with available transportation on GTN reduced to 50% of expected capacity.

NWP OUTAGE AT 50% CAPACITY – Same assumptions as in Reference Case Plus Peak with available transportation on NWP reduced to 50% of expected capacity.

JP OUTAGE AT 0% CAPACITY – Same assumptions as in Reference Case Plus Peak with available transportation from Jackson Prairie storage field reduced to 0% of expected capacity.

AECO OUTAGE AT 0% CAPACITY – Same assumptions as in Reference Case Plus Peak with available transportation from AECO reduced to 0% of expected capacity.

SUMAS OUTAGE AT 0% CAPACITY – Same assumptions as in Reference Case Plus Peak with available transportation from Sumas reduced to 0% of expected capacity.

ROCKIES OUTAGE AT 0% CAPACITY – Same assumptions as in Reference Case Plus Peak with available transportation from Rockies reduced to 0% of expected capacity.

GTN OUTAGE AT 0% CAPACITY – Same assumptions as in Reference Case Plus Peak with available transportation on GTN reduced to 0% of expected capacity.

NWP OUTAGE AT 0% CAPACITY – Same assumptions as in Reference Case Plus Peak with available transportation on NWP reduced to 0% of expected capacity.

Following are the Price Influencing (Indirect) Sensitivities we evaluated:

EXPECTED ELASTICITY – For our Expected Elasticity Sensitivity, we incorporate reduced consumption in response to higher natural gas prices by applying a price elasticity to demand. See Price Elasticity in Chapter 2: Demand Forecasts for further detail.

LOW & HIGH PRICES – To capture a wide range of alternative price forecasts, we performed a stochastic analysis based on the probability distribution of the expected price to develop 1,000 unique price forecasts around the expected price. Our high and low price forecasts represent the 95th and 25th highest percentile in each month of the 1,000 resultant price forecasts, respectively.

CARBON COST LOW CASE – Same assumptions as in Reference Case Plus Peak with consideration for price elasticity including the cost of carbon. The price of carbon in Idaho, Oregon, and Washington is set to \$0 in all years.

CARBON COST EXPECTED CASE – The price of carbon in Oregon was based on a Wood Mackenzie study for Cap and Trade. It begins with a 2021 price of \$15.83/MTCO_{2e} and rising to \$142.59 by 2045. The assumption is the cap and trade price will be similar to a cap and reduce price. Rules for EO 20-04 are still being developed and will be included in the 2023 IRP. Washington State was modeled using the required SCC @ 2.5%. This price begins at \$79.86 and increases yearly with a 2045 price of \$185.75 (2019\$). These values were provided by the WUTC Staff and are per their assumptions on inflation.

CARBON COST HIGH CASE – Assumes the EPA estimates on the social cost of carbon. Specifically, the high case includes 95% of results at a 3% discount rate average. These costs begin at \$112.20 in 2017 and increase to \$174 by 2037 for a metric ton of CO₂. This will measure the risk of carbon pricing in all three jurisdictions.

Following are the Emissions Influencing Sensitivities we evaluated:

HIGH UPSTREAM EMISSIONS – Same assumptions as in Carbon Cost Expected Case with an adjustment to upstream emissions. Expected upstream emissions are based on 0.79% methane leakage. Per a study performed by the Environmental Defense Fund, high upstream emissions are based on 2.47% methane leakage. Higher upstream emissions increase the associated cost of carbon per dekatherm.

EXPECTED UPSTREAM EMISSIONS – Same assumption as in Carbon Cost Expected Case.

NO UPSTREAM EMISSIONS – Same assumptions as in Carbon Cost Expected Case with an adjustment to upstream emissions. Expected upstream emissions are based on 0.79% methane leakage. No upstream emissions are based on 0% methane leakage. Lower upstream emissions decrease the associated cost of carbon per dekatherm.

20-YEAR GWP – Same assumptions as in Carbon Cost Expected Case with an adjustment to the time period over which the energy absorbed by a gas is measured relative to CO₂ and converted into its Global Warming Potential. The time period of 100 years used for the expected GWP is reduced to 20 years. The shorter lifetime of methane relative to CO₂ results in a more significant GWP when the measurement's time period is reduced.

100-YEAR GWP – Same assumptions as in Carbon Cost Expected Case.

SCENARIOS

After identifying the above demand drivers and analyzing the various Sensitivities, we have developed the following demand forecast Scenarios:

AVERAGE CASE – This Scenario we believe represents the most likely average demand forecast modeled. We assume service territory customer growth rates consistent with the reference case, rolling 20 year normal weather in each service territory, our expected natural gas price forecast (blend of two consultants and the U.S. Energy Information Administration's Annual Energy Outlook, along with the NYMEX forward strip), expected price elasticity, the CO₂ cost adders from our Carbon Cost Expected Case Sensitivity, 100 year GWP, and DSM. The Scenario does not include incremental cost adders for declining Canadian imports or drilling restrictions beyond what is incorporated in the selected price forecast.

EXPECTED CASE – This Scenario represents the peak demand forecast. We assume service territory customer growth rates consistent with the reference case, a weather standard of coldest day on record in each service territory, our expected natural gas price forecast (blend of two consultants and the U.S. Energy Information Administration's Annual Energy Outlook, along with the NYMEX forward strip), expected price elasticity, 100 year GWP, DSM, and the CO₂ cost adders from our Carbon Cost Expected Case Sensitivity.

HIGH GROWTH, LOW PRICE – This Scenario models a rapid return to robust growth in part spurred on by low energy prices. We assume higher customer growth rates than the reference case, coldest day on record weather standard, our low natural gas price forecast, expected price elasticity, 100 year GWP, DSM, and no CO₂ adders.

LOW GROWTH, HIGH PRICE – This Scenario models an extended period of slow economic growth in part resulting from high energy prices. We assume lower customer growth rates than the reference case, coldest day on record weather standard, our high natural gas price forecast, expected price elasticity, 100 year GWP, DSM, and CO2 adders from our Carbon Cost High Case Sensitivity.

80% BELOW 1990 EMISSIONS – This Scenario models the impact of potential consumption curtailment due to carbon legislation coupled with low energy prices. We assume a straight line reduction in Washington and Oregon consumption from reference case growth in order to meet 80% below 1990 emission levels by 2050, along with our low natural gas price forecast rather than our expected natural gas price forecast. All other assumptions remain the same as our Expected Case Scenario.

APPENDIX 2.7: ANNUAL DEMAND, AVERAGE DAY DEMAND AND PEAK DAY DEMAND (NET OF DSM) – CASE LOW GROWTH

Scenario	Gas Year	Annual Demand	Daily Demand	Peak Day	Annual Demand	Daily Demand	Peak Day	Annual Demand	Daily Demand	Peak Day	Annual Demand	Daily Demand	Peak Day
		Klamath Falls (MDth)	Klamath Falls (MDth/day)	Klamath Falls (MDth/day)	La Grande (MDth)	La Grande (MDth/day)	La Grande (MDth/day)	Medford/Roseburg (MDth)	Medford/Roseburg (MDth/day)	Medford/Roseburg (MDth/day)			
Low Growth & High Prices	2019-2020	1,426.57	3.90	14.74	853.39	2.33	8.27	6,855.58	18.73	67.27			
Low Growth & High Prices	2020-2021	1,392.75	3.82	14.49	821.59	2.25	8.13	6,817.71	18.68	67.54			
Low Growth & High Prices	2021-2022	759.51	2.08	6.37	510.49	1.40	3.75	4,197.95	11.50	31.28			
Low Growth & High Prices	2022-2023	752.97	2.06	6.28	499.18	1.37	3.70	4,202.93	11.51	31.14			
Low Growth & High Prices	2023-2024	756.45	2.07	6.29	496.96	1.36	3.69	4,250.88	11.61	31.37			
Low Growth & High Prices	2024-2025	752.93	2.06	6.29	490.31	1.34	3.68	4,257.22	11.66	31.56			
Low Growth & High Prices	2025-2026	753.43	2.06	6.30	487.01	1.33	3.66	4,281.51	11.73	31.79			
Low Growth & High Prices	2026-2027	753.42	2.06	6.31	483.21	1.32	3.65	4,299.56	11.78	31.96			
Low Growth & High Prices	2027-2028	757.53	2.07	6.32	483.70	1.32	3.64	4,338.30	11.85	32.09			
Low Growth & High Prices	2028-2029	754.90	2.07	6.33	477.47	1.31	3.63	4,333.70	11.87	32.22			
Low Growth & High Prices	2029-2030	756.55	2.07	6.36	475.46	1.30	3.61	4,350.20	11.92	32.38			
Low Growth & High Prices	2030-2031	758.66	2.08	6.38	473.71	1.30	3.60	4,367.91	11.97	32.51			
Low Growth & High Prices	2031-2032	764.89	2.09	6.40	475.76	1.30	3.59	4,408.45	12.04	32.66			
Low Growth & High Prices	2032-2033	763.88	2.09	6.43	471.01	1.29	3.59	4,401.85	12.06	32.79			
Low Growth & High Prices	2033-2034	766.99	2.10	6.46	470.19	1.29	3.58	4,418.42	12.11	32.94			
Low Growth & High Prices	2034-2035	770.02	2.11	6.49	469.62	1.29	3.58	4,434.79	12.15	33.06			
Low Growth & High Prices	2035-2036	777.58	2.12	6.51	473.17	1.29	3.58	4,477.21	12.23	33.19			
Low Growth & High Prices	2036-2037	777.37	2.13	6.54	470.25	1.29	3.58	4,472.54	12.25	33.33			
Low Growth & High Prices	2037-2038	781.38	2.14	6.58	471.01	1.29	3.59	4,490.79	12.30	33.48			
Low Growth & High Prices	2038-2039	785.69	2.15	6.61	471.79	1.29	3.59	4,507.25	12.35	33.61			
Low Growth & High Prices	2039-2040	795.14	2.17	6.65	476.95	1.30	3.61	4,553.17	12.44	33.73			

Scenario	Gas Year	Annual Demand	Daily Demand	Peak Day	Annual Demand	Daily Demand	Peak Day	Annual Demand	Daily Demand	Peak Day	Annual Demand	Daily Demand	Peak Day
		Oregon (MDth)	Oregon (MDth/day)	Oregon (MDth/day)	Washington (MDth)	Washington (MDth/day)	Washington (MDth/day)	Idaho (MDth)	Idaho (MDth/day)	Idaho (MDth/day)	Total System (MDth)	Total System (MDth/day)	Total System (MDth/day)
Low Growth & High Prices	2019-2020	9,135.54	24.96	88.64	18,081.89	49.40	178.46	9,706.05	26.52	95.47	36,923.49	100.88	346.27
Low Growth & High Prices	2020-2021	9,032.06	24.75	88.54	17,804.05	48.78	177.97	9,540.59	26.14	94.85	36,376.70	99.66	344.94
Low Growth & High Prices	2021-2022	5,467.95	14.98	40.75	9,952.51	27.27	79.56	5,412.27	14.83	42.55	20,832.74	57.08	156.34
Low Growth & High Prices	2022-2023	5,455.08	14.95	40.46	9,886.58	27.09	78.90	5,360.76	14.69	42.11	20,702.42	56.72	155.06
Low Growth & High Prices	2023-2024	5,504.30	15.04	40.67	10,007.73	27.34	79.53	5,430.01	14.84	42.52	20,942.04	57.22	156.22
Low Growth & High Prices	2024-2025	5,500.46	15.07	40.85	9,964.46	27.30	79.79	5,400.42	14.80	42.60	20,865.34	57.17	156.74
Low Growth & High Prices	2025-2026	5,521.94	15.13	41.08	9,985.35	27.36	80.15	5,396.73	14.79	42.70	20,904.02	57.27	157.32
Low Growth & High Prices	2026-2027	5,536.20	15.17	41.25	10,016.59	27.44	80.54	5,396.31	14.78	42.79	20,949.10	57.39	157.91
Low Growth & High Prices	2027-2028	5,579.53	15.24	41.38	10,123.31	27.66	80.99	5,438.12	14.86	42.93	21,140.95	57.76	158.61
Low Growth & High Prices	2028-2029	5,566.06	15.25	41.50	10,085.56	27.63	81.32	5,403.28	14.80	43.01	21,054.90	57.68	159.15
Low Growth & High Prices	2029-2030	5,582.20	15.29	41.68	10,123.96	27.74	81.74	5,406.05	14.81	43.09	21,112.21	57.84	159.75
Low Growth & High Prices	2030-2031	5,600.28	15.34	41.81	10,168.48	27.86	82.16	5,415.13	14.84	43.23	21,183.89	58.04	160.45
Low Growth & High Prices	2031-2032	5,649.10	15.43	41.98	10,294.69	28.13	82.67	5,466.47	14.94	43.41	21,410.26	58.50	161.26
Low Growth & High Prices	2032-2033	5,636.75	15.44	42.13	10,278.86	28.16	83.08	5,440.74	14.91	43.52	21,356.34	58.51	161.91
Low Growth & High Prices	2033-2034	5,655.60	15.49	42.30	10,343.82	28.34	83.56	5,462.39	14.97	43.70	21,461.82	58.80	162.68
Low Growth & High Prices	2034-2035	5,674.43	15.55	42.45	10,407.67	28.51	84.02	5,488.90	15.04	43.91	21,571.00	59.10	163.48
Low Growth & High Prices	2035-2036	5,727.97	15.65	42.60	10,549.24	28.82	84.55	5,556.26	15.18	44.15	21,833.47	59.65	164.40
Low Growth & High Prices	2036-2037	5,720.16	15.67	42.78	10,543.59	28.89	85.00	5,542.57	15.19	44.32	21,806.32	59.74	165.15
Low Growth & High Prices	2037-2038	5,743.18	15.73	42.97	10,604.05	29.05	85.43	5,564.75	15.25	44.50	21,911.99	60.03	165.90
Low Growth & High Prices	2038-2039	5,764.73	15.79	43.13	10,660.78	29.21	85.85	5,586.95	15.31	44.68	22,012.46	60.31	166.64
Low Growth & High Prices	2039-2040	5,825.26	15.92	43.30	10,791.38	29.48	86.29	5,647.85	15.43	44.88	22,264.50	60.83	167.48

APPENDIX 2.7: ANNUAL DEMAND, AVERAGE DAY DEMAND AND

Scenario	Gas Year	Annual Demand	Daily Demand	Peak Day	Annual Demand	Daily Demand	Peak Day	Annual Demand	Daily Demand	Peak Day
		Klamath Falls (MDth)	Klamath Falls (MDth/day)	Klamath Falls (MDth/day)	La Grande (MDth)	La Grande (MDth/day)	La Grande (MDth/day)	Medford/Roseburg (MDth)	Medford/Roseburg (MDth/day)	Medford/Roseburg (MDth/day)
Electrification & Carbon Reduction	2019-2020	1,431.68	3.91	14.74	866.76	2.37	8.27	6,861.29	18.75	67.27
Electrification & Carbon Reduction	2020-2021	1,434.26	3.93	14.87	859.81	2.36	8.31	6,864.75	18.81	67.94
Electrification & Carbon Reduction	2021-2022	1,391.90	3.81	14.28	839.39	2.30	8.01	6,711.03	18.39	65.38
Electrification & Carbon Reduction	2022-2023	1,405.20	3.85	14.42	844.46	2.31	8.05	6,789.13	18.60	66.12
Electrification & Carbon Reduction	2023-2024	1,424.78	3.89	14.54	857.10	2.34	8.10	6,903.05	18.86	66.82
Electrification & Carbon Reduction	2024-2025	1,426.81	3.91	14.65	853.42	2.34	8.15	6,932.56	18.99	67.52
Electrification & Carbon Reduction	2025-2026	1,436.98	3.94	14.76	857.74	2.35	8.19	7,005.50	19.19	68.25
Electrification & Carbon Reduction	2026-2027	1,433.78	3.93	14.71	855.97	2.35	8.15	7,021.55	19.24	68.25
Electrification & Carbon Reduction	2027-2028	1,450.21	3.96	14.79	867.45	2.37	8.19	7,129.94	19.48	68.87
Electrification & Carbon Reduction	2028-2029	1,440.23	3.95	14.76	858.76	2.35	8.16	7,106.20	19.47	68.94
Electrification & Carbon Reduction	2029-2030	1,437.77	3.94	14.72	857.77	2.35	8.14	7,123.63	19.52	69.00
Electrification & Carbon Reduction	2030-2031	1,444.61	3.96	14.79	861.27	2.36	8.18	7,179.02	19.67	69.53
Electrification & Carbon Reduction	2031-2032	1,460.77	3.99	14.86	873.14	2.39	8.22	7,282.30	19.90	70.07
Electrification & Carbon Reduction	2032-2033	1,459.29	4.00	14.95	868.64	2.38	8.25	7,286.90	19.96	70.61
Electrification & Carbon Reduction	2033-2034	1,456.43	3.99	14.89	867.56	2.38	8.22	7,294.77	19.99	70.52
Electrification & Carbon Reduction	2034-2035	1,463.39	4.01	14.97	871.06	2.39	8.26	7,342.80	20.12	71.00
Electrification & Carbon Reduction	2035-2036	1,479.49	4.04	15.04	882.76	2.41	8.30	7,440.12	20.33	71.46
Electrification & Carbon Reduction	2036-2037	1,478.51	4.05	15.12	878.43	2.41	8.34	7,441.58	20.39	71.93
Electrification & Carbon Reduction	2037-2038	1,486.30	4.07	15.20	882.12	2.42	8.37	7,490.04	20.52	72.40
Electrification & Carbon Reduction	2038-2039	1,494.24	4.09	15.28	885.57	2.43	8.41	7,536.29	20.65	72.85
Electrification & Carbon Reduction	2039-2040	1,511.59	4.13	15.36	897.67	2.45	8.44	7,633.16	20.86	73.29

Scenario	Gas Year	Annual Demand	Daily Demand	Peak Day	Annual Demand	Daily Demand	Peak Day	Annual Demand	Daily Demand	Peak Day	Annual Demand	Daily Demand	Peak Day
		Oregon (MDth)	Oregon (MDth/day)	Oregon (MDth/day)	Washington (MDth)	Washington (MDth/day)	Washington (MDth/day)	Idaho (MDth)	Idaho (MDth/day)	Idaho (MDth/day)	Total System (MDth)	Total System (MDth/day)	Total System (MDth/day)
Electrification & Carbon Reduction	2019-2020	9,159.72	25.03	88.64	18,098.76	49.45	178.46	9,725.02	26.57	95.47	36,983.49	101.05	346.27
Electrification & Carbon Reduction	2020-2021	9,158.82	25.09	89.44	18,062.12	49.49	180.05	9,725.34	26.64	96.44	36,946.27	101.22	349.46
Electrification & Carbon Reduction	2021-2022	8,942.33	24.50	86.02	15,016.07	41.14	141.26	9,806.47	26.87	97.31	33,764.87	92.51	309.10
Electrification & Carbon Reduction	2022-2023	9,038.78	24.76	86.92	15,065.78	41.28	141.49	9,929.11	27.20	98.56	34,033.67	93.24	311.30
Electrification & Carbon Reduction	2023-2024	9,184.93	25.10	87.80	15,354.91	41.95	143.09	10,161.96	27.76	100.06	34,701.80	94.81	315.03
Electrification & Carbon Reduction	2024-2025	9,212.79	25.24	88.63	15,383.96	42.15	144.58	10,204.57	27.96	101.41	34,801.32	95.35	318.56
Electrification & Carbon Reduction	2025-2026	9,300.22	25.48	89.50	15,531.68	42.55	146.05	10,237.36	28.05	101.59	35,069.26	96.08	320.87
Electrification & Carbon Reduction	2026-2027	9,311.30	25.51	89.42	15,676.32	42.95	147.47	10,200.85	27.95	100.90	35,188.47	96.41	321.49
Electrification & Carbon Reduction	2027-2028	9,447.59	25.81	90.16	15,950.91	43.58	148.88	10,381.86	28.37	101.86	35,780.37	97.76	324.45
Electrification & Carbon Reduction	2028-2029	9,405.20	25.77	90.17	15,960.18	43.73	150.26	10,380.87	28.44	102.79	35,746.24	97.93	326.77
Electrification & Carbon Reduction	2029-2030	9,419.18	25.81	90.17	16,101.50	44.11	151.65	10,471.06	28.69	103.73	35,991.74	98.61	329.05
Electrification & Carbon Reduction	2030-2031	9,484.90	25.99	90.80	16,230.47	44.47	152.90	10,564.90	28.94	104.69	36,280.27	99.40	331.80
Electrification & Carbon Reduction	2031-2032	9,616.22	26.27	91.45	16,492.34	45.06	154.12	10,753.95	29.38	105.69	36,862.51	100.72	334.55
Electrification & Carbon Reduction	2032-2033	9,614.83	26.34	92.09	16,478.59	45.15	155.32	10,756.09	29.47	106.67	36,849.51	100.96	337.20
Electrification & Carbon Reduction	2033-2034	9,618.76	26.35	91.94	16,600.50	45.48	156.51	10,788.76	29.56	106.84	37,008.02	101.39	338.43
Electrification & Carbon Reduction	2034-2035	9,677.25	26.51	92.52	16,719.56	45.81	157.65	10,889.73	29.83	107.87	37,286.54	102.15	341.07
Electrification & Carbon Reduction	2035-2036	9,802.37	26.78	93.08	16,982.35	46.40	158.82	11,090.44	30.30	108.93	37,875.16	103.48	343.76
Electrification & Carbon Reduction	2036-2037	9,798.52	26.85	93.66	16,960.20	46.47	159.94	11,097.59	30.40	109.97	37,856.31	103.72	346.38
Electrification & Carbon Reduction	2037-2038	9,858.45	27.01	94.24	17,075.82	46.78	161.04	11,202.89	30.69	111.04	38,137.16	104.49	349.00
Electrification & Carbon Reduction	2038-2039	9,916.10	27.17	94.79	17,190.01	47.10	162.13	11,309.35	30.98	112.11	38,415.46	105.25	351.60
Electrification & Carbon Reduction	2039-2040	10,042.43	27.44	95.34	17,447.22	47.67	163.20	11,514.51	31.46	113.19	39,004.15	106.57	354.22

APPENDIX 2.8: PEAK DAY DEMAND BEFORE AND AFTER DSM WASHINGTON

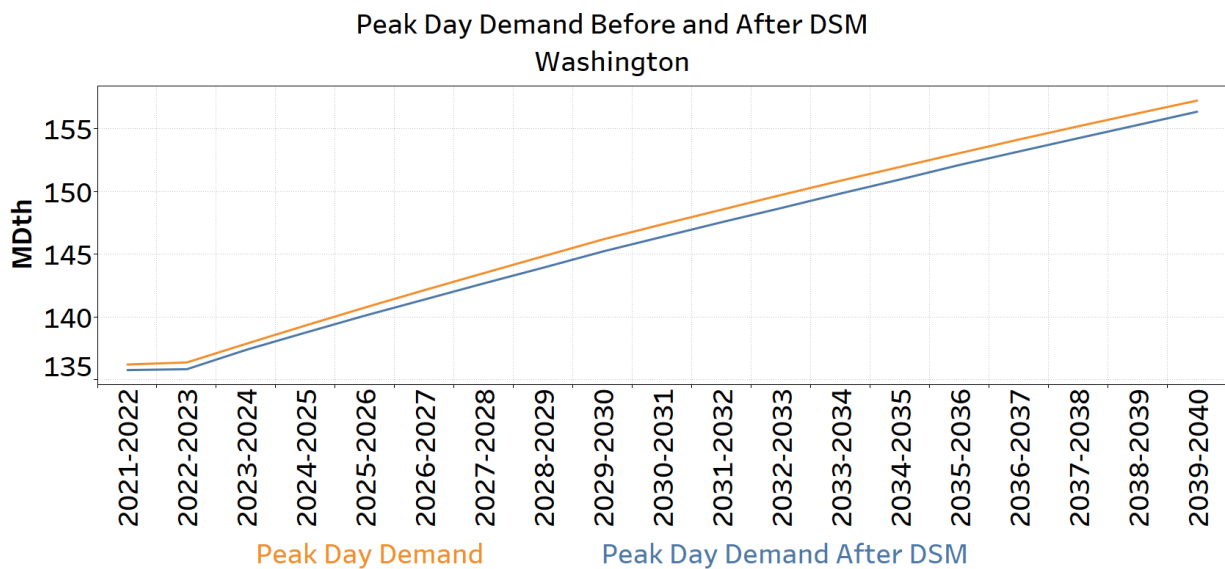
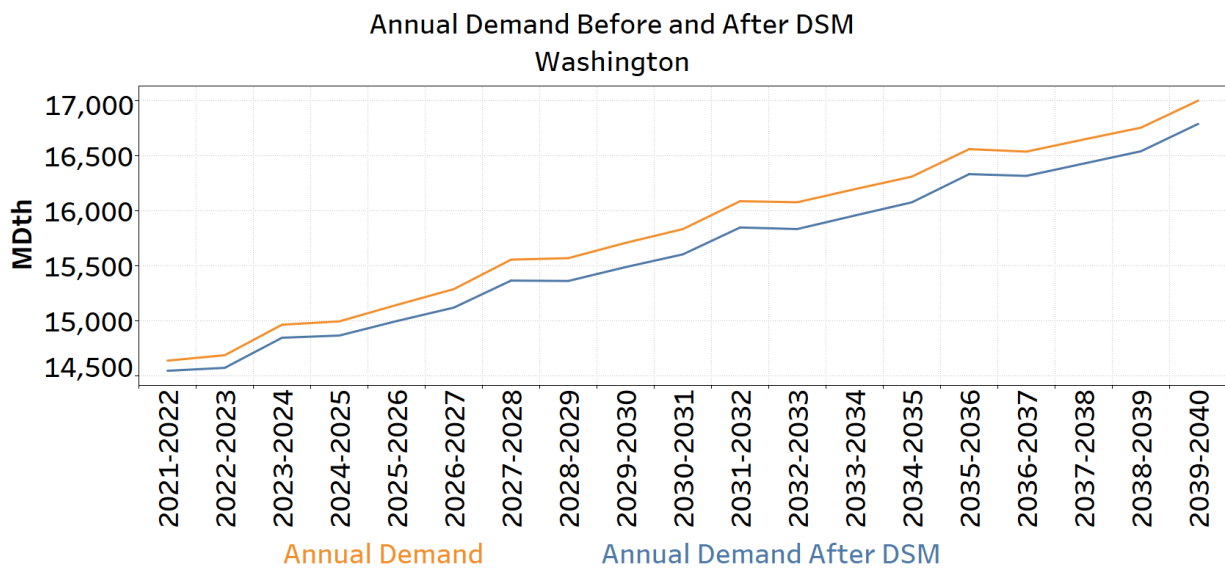

APPENDIX 2.8: PEAK DAY DEMAND BEFORE AND AFTER DSM IDAHO

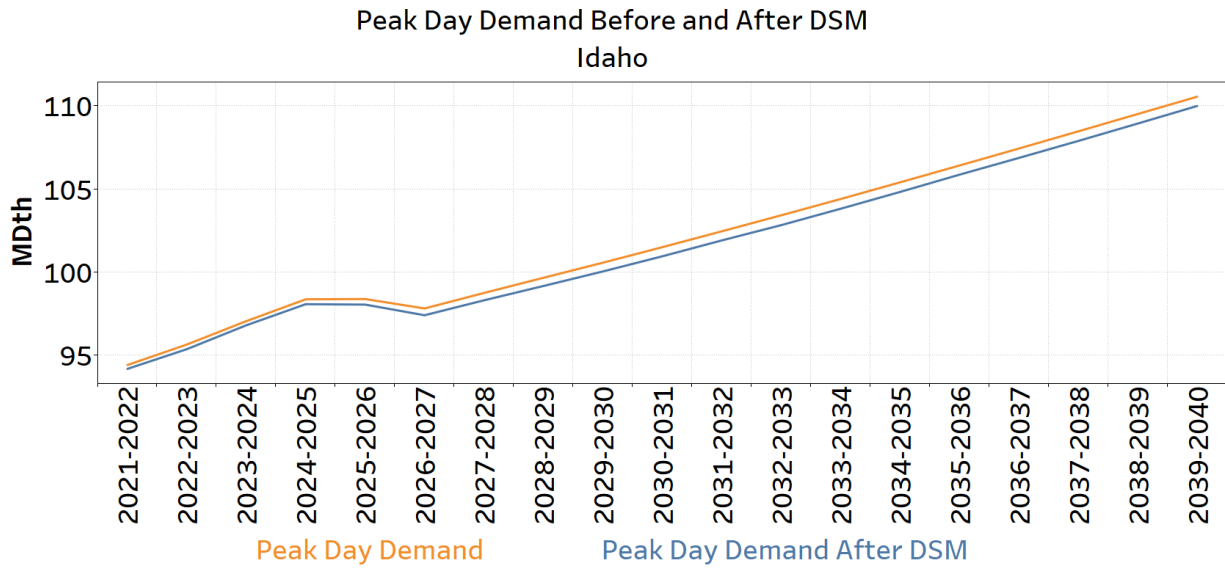
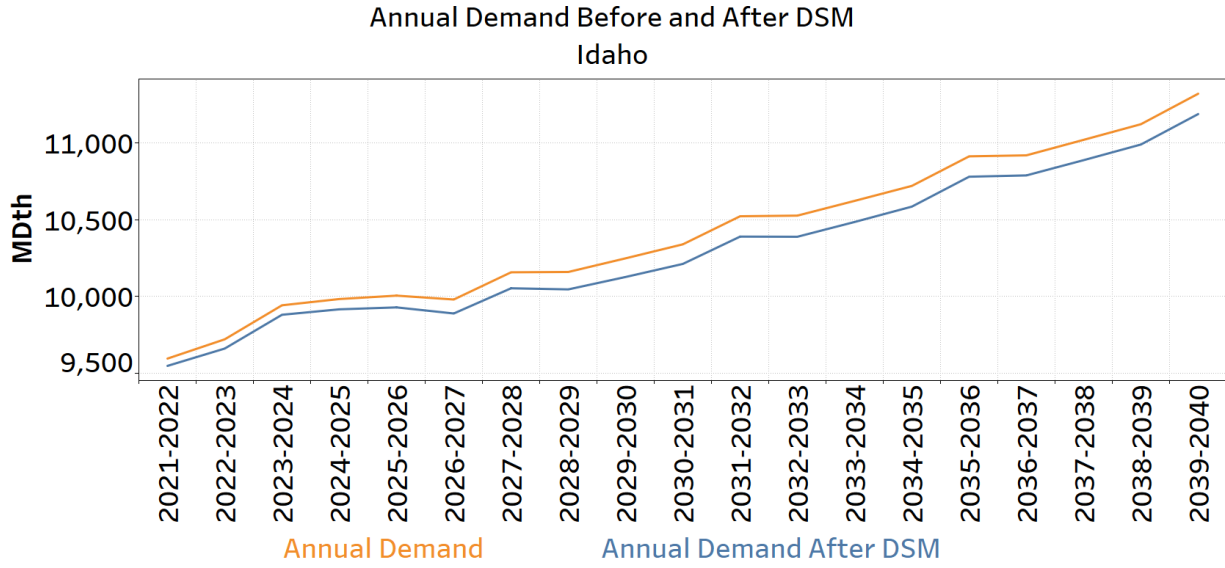

APPENDIX 2.8: PEAK DAY DEMAND BEFORE AND AFTER DSM MEDFORD/ROSEBURG

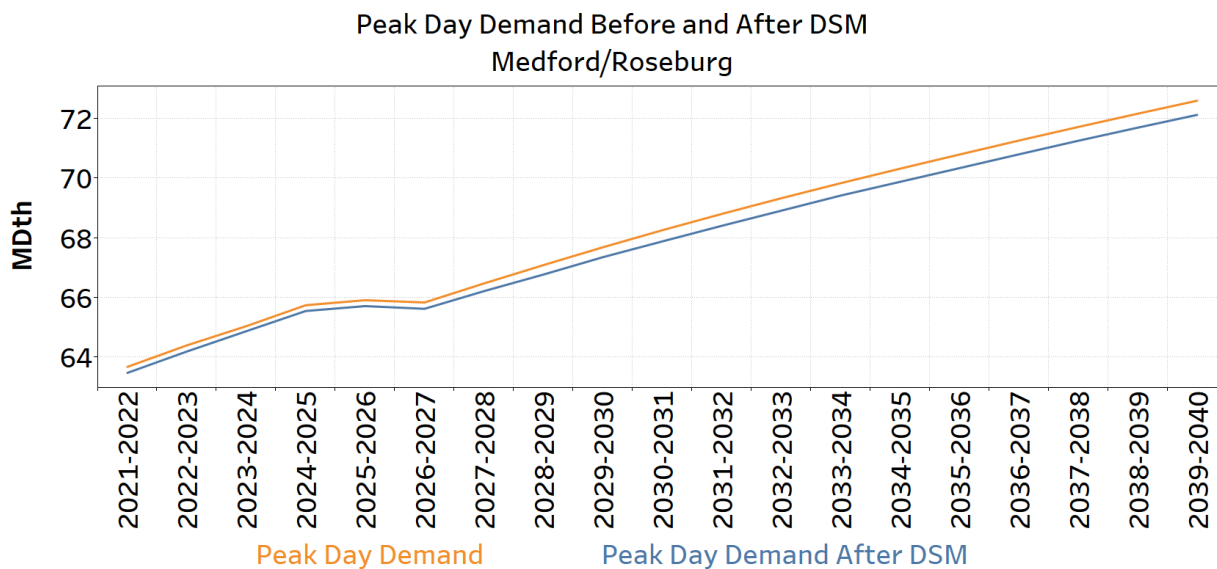
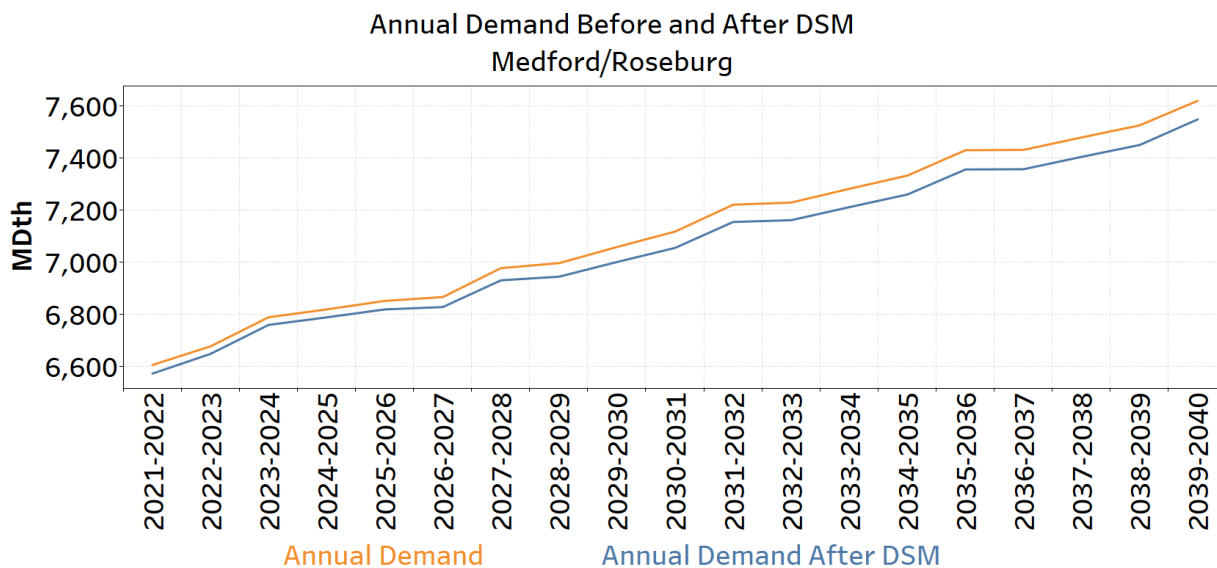

APPENDIX 2.8: PEAK DAY DEMAND BEFORE AND AFTER DSM KLAMATH FALLS

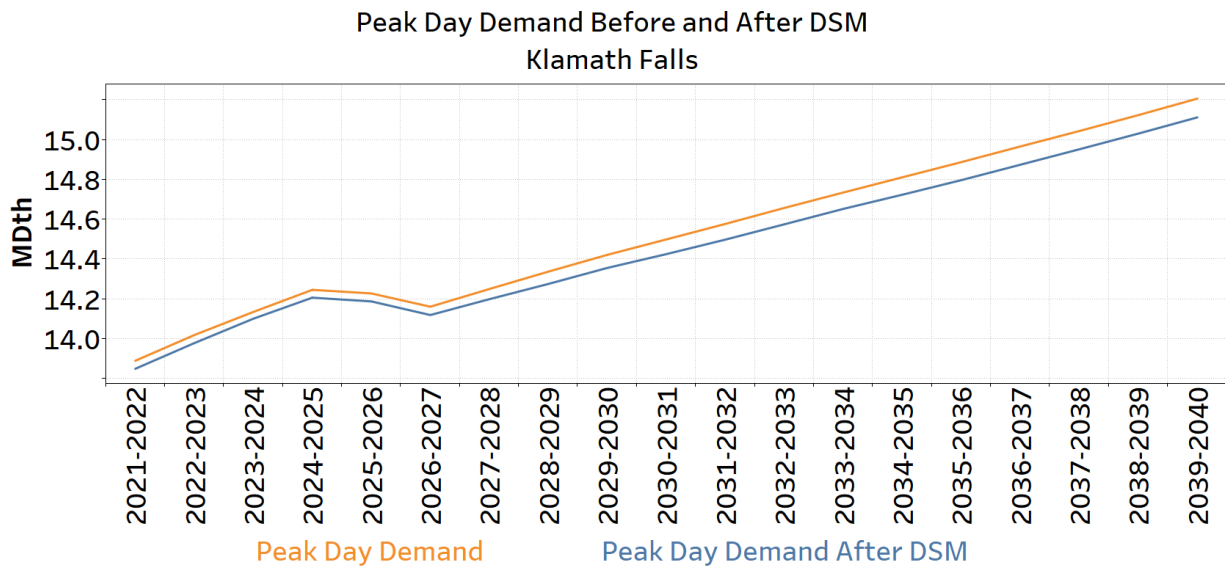
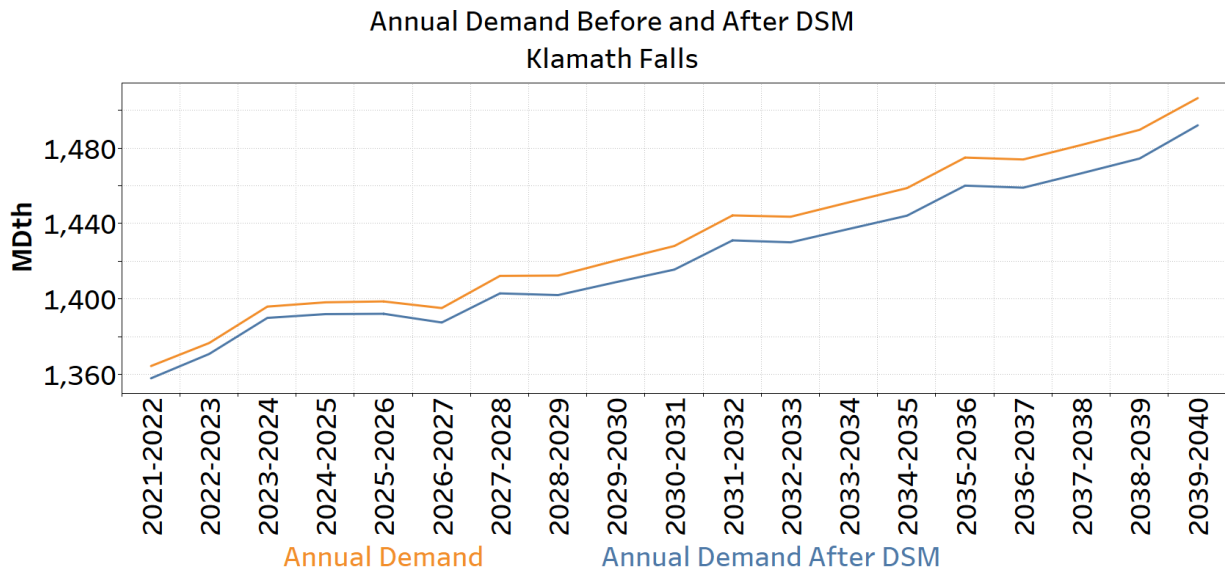

APPENDIX 2.8: PEAK DAY DEMAND BEFORE AND AFTER DSM LA GRANDE

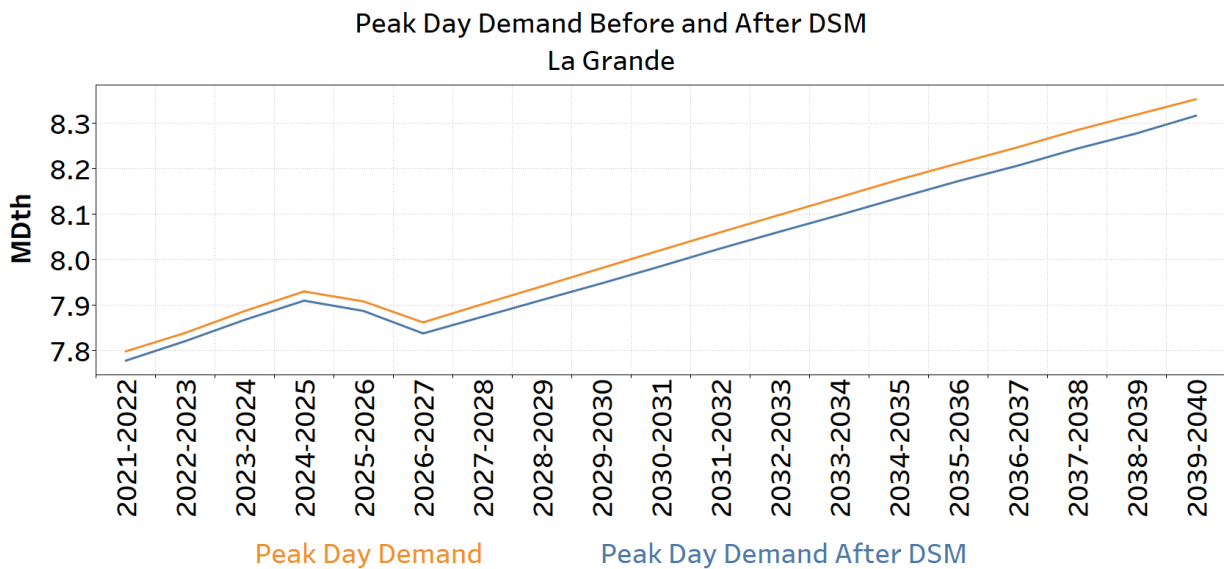
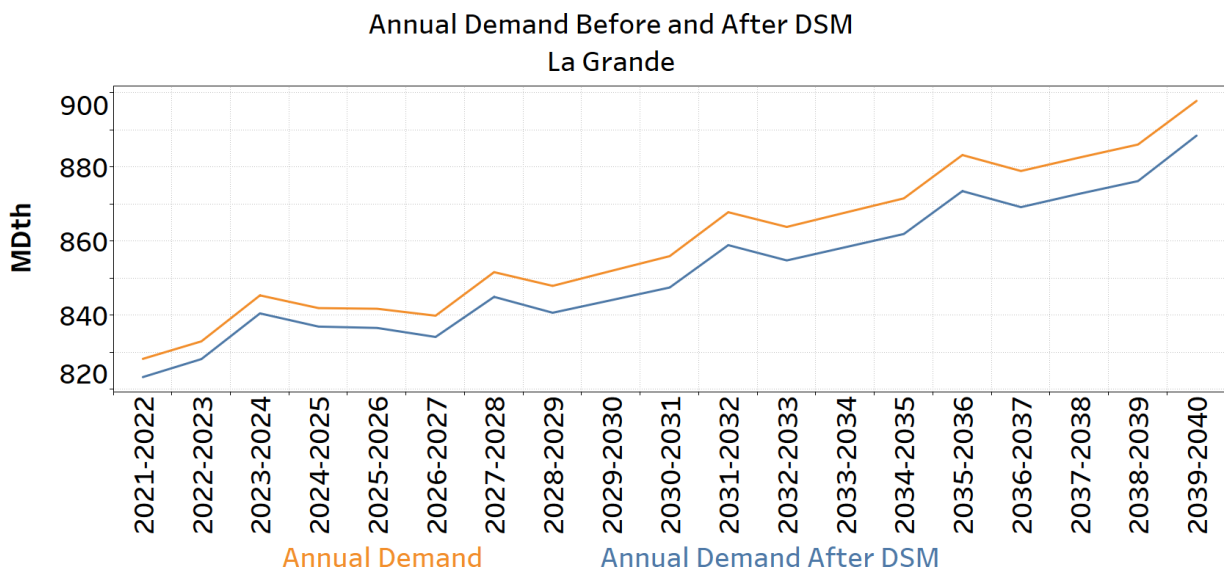

Area	2037-2038:			2037-2038:	2038-2039:			2038-2039:	2039-2040:			2039-2040:
	Residential	Commercial	Industrial	Total	Residential	Commercial	Industrial	Total	Residential	Commercial	Industrial	Total
Klamath Falls	938.22	477.54	13.18	1,428.94	943.16	480.21	13.18	1,436.55	953.45	485.63	13.23	1,452.31
La Grande	483.66	314.30	54.11	852.07	485.69	315.58	54.12	855.40	490.06	318.63	54.23	862.93
Medford GTN	2,496.59	1,564.21	26.05	4,086.85	2,515.17	1,575.56	26.64	4,117.36	2,546.76	1,594.86	27.32	4,168.94
Medford NWP	1,083.29	678.69	7.11	1,769.08	1,089.93	682.72	7.11	1,779.76	1,102.23	690.22	7.14	1,799.60
Roseburg	751.30	594.29	2.53	1,348.12	753.87	594.97	2.53	1,351.37	760.93	599.13	2.54	1,362.60
Oregon Subtotal	5,753.05	3,629.03	102.98	9,485.05	5,787.82	3,649.05	103.59	9,540.45	5,853.43	3,688.47	104.46	9,646.36
Washington Both	6,267.55	2,888.69	122.84	9,279.07	6,319.68	2,901.01	121.79	9,342.47	6,397.81	2,924.17	121.22	9,443.20
Washington GTN	850.16	459.93	16.47	1,326.56	857.23	461.83	16.33	1,335.39	867.87	465.61	16.25	1,349.73
Washington NWP	3,674.08	1,693.37	72.01	5,439.46	3,704.64	1,700.59	71.39	5,476.62	3,750.44	1,714.17	71.06	5,535.67
Washington Subtotal	10,791.79	5,041.99	211.31	16,045.09	10,881.55	5,063.43	209.51	16,154.49	11,016.11	5,103.95	208.53	16,328.60
Idaho Both	4,043.82	1,982.21	132.44	6,158.47	4,095.17	1,989.96	131.03	6,216.16	4,164.61	2,005.37	130.11	6,300.09
Idaho GTN	557.77	273.41	18.27	849.44	564.85	274.48	18.07	857.40	574.43	276.60	17.95	868.98
Idaho NWP	2,370.51	1,161.98	77.64	3,610.13	2,400.62	1,166.53	76.81	3,643.96	2,441.33	1,175.56	76.27	3,693.16
Idaho Subtotal	6,972.10	3,417.60	228.35	10,618.04	7,060.64	3,430.97	225.92	10,717.52	7,180.37	3,457.54	224.32	10,862.23
Case Total	23,516.93	12,088.61	542.64	36,148.19	23,730.00	12,143.44	539.02	36,412.46	24,049.91	12,249.96	537.31	36,837.19



2020 AVISTA UTILITIES NATURAL GAS CONSERVATION POTENTIAL ASSESSMENT

Volume 1, Final Report

December 1, 2020

Report prepared for:
AVISTA UTILITIES

Energy Solutions. Delivered.

This work was performed by:

Applied Energy Group, Inc.
500 Ygnacio Valley Road, Suite 250
Walnut Creek, CA 94596

Project Director: I. Rohmund

Project Manager: K. Walter

AEG would also like to acknowledge the valuable contributions of

Avista Utilities
1411 E Mission MSC-15
Spokane, WA 99220

Project Team: Ryan Finesilver
James Gall
Leona Haley
Tom Pardee

EXECUTIVE SUMMARY

Early in 2020, Avista Utilities (Avista) contracted with Applied Energy Group (AEG) to conduct this Conservation Potential Assessment (CPA) in support of their conservation and resource planning activities. This report documents this effort and provides estimates of the potential reductions in annual energy usage for natural gas customers in Avista's Washington and Idaho service territories from energy conservation efforts in the time period of 2021 to 2040. To produce a reliable and transparent estimate of energy efficiency (EE) resource potential, the AEG team performed the following tasks to meet Avista's key objectives:

- Used information and data from Avista, as well as secondary data sources, to describe how customers currently use gas by sector, segment, end use and technology.
- Developed a baseline projection of how customers are likely to use gas in absence of future EE programs. This defines the metric against which future program savings are measured. This projection used up-to-date technology data, modeling assumptions, and energy baselines that reflect both current and anticipated federal, state, and local energy efficiency legislation that will impact energy EE potential.
- Estimated the technical, achievable technical, and achievable economic potential at the measure level for energy efficiency within Avista's service territory over the 2021 to 2040 planning horizon.
- Delivered a fully configured end-use conservation planning model, LoadMAP, for Avista to use in future potential and resource planning initiatives

In summary, the potential study provided a solid foundation for the development of Avista's energy savings targets.

Table ES-1 summarizes the results for Avista's Washington territory at a high level. AEG analyzed potential for the residential, commercial, and industrial market sectors. First-year utility cost test (UCT) achievable economic potential in Washington is 75,820 dekatherms. This increases to a cumulative total of 173,838 dekatherms in the second year and 1,386,479 dekatherms by the tenth year (2030).

Table ES-1 Washington Conservation Potential by Case, Selected Years (dekatherms)

Scenario	2021	2022	2023	2030	2040
Baseline Forecast (Dth)	19,118,293	19,289,575	19,805,020	20,612,516	21,619,876
Cumulative Savings (Dth)					
UCT Achievable Economic	75,820	173,838	457,423	1,386,479	3,560,512
Achievable Technical	41,871	416,584	1,221,810	3,183,398	6,309,826
Technical	187,983	897,098	2,314,334	5,084,999	8,908,493
Energy Savings (% of Baseline)					
UCT Achievable Economic Potential	0.4%	0.9%	2.3%	6.7%	16.5%
Achievable Technical Potential	0.2%	2.2%	6.2%	15.4%	29.2%
Technical Potential	1.0%	4.7%	11.7%	24.7%	41.2%

Table ES-2 summarizes the results for Avista's Idaho territory at a high level. First-year utility cost test (UCT) achievable economic potential in Idaho is 35,816 dekatherms. This increases to a cumulative total of 87,995 dekatherms in the second year and 737,710 dekatherms by the tenth year (2030).

Table ES-2 Idaho Conservation Potential by Case, Selected Years (dekatherms)

Scenario	2021	2022	2023	2030	2040
Baseline Forecast (Dth)	10,019,377	10,144,894	10,520,169	11,004,568	12,006,819
Cumulative Savings (Dth)					
UCT Achievable Economic	35,816	87,995	229,283	737,710	2,025,410
Achievable Technical	26,220	226,613	657,997	1,722,830	3,544,048
Technical	102,031	490,826	1,273,202	2,777,509	5,013,697
Energy Savings (% of Baseline)					
UCT Achievable Economic Potential	0.4%	0.9%	2.2%	6.7%	16.9%
Achievable Technical Potential	0.3%	2.2%	6.3%	15.7%	29.5%
Technical Potential	1.0%	4.8%	12.1%	25.2%	41.8%

As part of this study, we also estimated total resource cost (TRC) potential, with the focus of fully balancing non-energy impacts. This includes the use of full measure costs as well as quantified and monetizable non-energy impacts and non-gas fuel impacts (e.g. electric cooling or wood secondary heating) consistent with methodology within the 2021 Northwest Conservation and Electric Power Plan (2021 Plan). We explore this potential in more detail throughout the report.

CONTENTS

	Executive Summary	i
1	INTRODUCTION	1
	Goals of the Conservation Potential Assessment.....	1
	Summary of Report Contents	2
	Abbreviations and Acronyms.....	4
2	ANALYSIS APPROACH AND DATA DEVELOPMENT	5
	Overview of Analysis Approach.....	5
	Comparison with Northwest Power & Conservation Council Methodology	5
	LoadMAP Model.....	6
	Definitions of Potential.....	7
	Market Characterization.....	9
	Baseline Projection.....	10
	Energy Efficiency Measure Development.....	11
	Calculation of Energy Conservation Potential.....	14
	Data Development	16
	Data Sources.....	16
	Application of Data to the Analysis	19
3	MARKET CHARACTERIZATION AND MARKET PROFILES	25
	Overall Energy Use Summary.....	25
	Residential Sector	27
	Washington Characterization	27
	Idaho Characterization	29
	Commercial Sector	32
	Washington Characterization	32
	Idaho Characterization	35
	Industrial Sector	38
	Washington Characterization	38
	Idaho Characterization	39
4	BASELINE PROJECTION	41
	Overall Baseline Projection	42
	Washington Projection	42
	Idaho Projection	43
	Residential Sector	44
	Washington Projection	44
	Idaho Projection	45
	Commercial Sector	46
	Washington Projection	46
	Idaho Projection	47
	Industrial Sector	48
	Washington Projection	48
	Idaho Projection	49
5	OVERALL ENERGY EFFICIENCY POTENTIAL	50

Overall Energy Efficiency Potential	50
Washington Potential	50
Idaho Potential.....	54
6 SECTOR-LEVEL ENERGY EFFICIENCY POTENTIAL	57
Residential Sector	57
Washington Potential.....	57
Idaho Potential.....	61
Commercial Sector	64
Washington Potential.....	64
Idaho Potential.....	67
Industrial Sector	70
Washington Potential.....	70
Idaho Potential.....	73
Incorporating the Total Resource Cost Test	76
7 COMPARISON WITH CURRENT PROGRAMS	77
Washington Comparison with 2019 Programs	77
Residential Sector	77
Commercial and Industrial Sectors.....	78
Idaho Comparison with 2019 Programs	79
Residential Sector	79
Commercial and Industrial Sectors.....	80
8 COMPARISON WITH PREVIOUS STUDY	81
Residential Comparison with 2018 CPA	81
Nonresidential Comparison with 2018 CPA	81

LIST OF FIGURES

Figure 1-1	Avista's Service Territory (courtesy Avista)	2
Figure 2-1	LoadMAP Analysis Framework.....	7
Figure 2-2	Approach for ECM Assessment	12
Figure 3-1	Sector-Level Natural Gas Use in Base Year 2015, Washington (annual therms, percent)	25
Figure 3-2	Sector-Level Natural Gas Use in Base Year 2015, Idaho (annual therms, percent)	26
Figure 3-3	Residential Natural Gas Use by Segment, Washington, 2015	27
Figure 3-4	Residential Natural Gas Use by End Use, Washington, 2015	28
Figure 3-5	Residential Energy Intensity by End Use and Segment, Washington, 2015 (Annual Therms/HH).....	28
Figure 3-6	Residential Natural Gas Use by Segment, Idaho, 2015	30
Figure 3-7	Residential Natural Gas Use by End Use, Idaho, 2015.....	30
Figure 3-8	Residential Energy Intensity by End Use and Segment, Idaho, 2015 (Annual Therms/HH).....	31
Figure 3-9	Commercial Natural Gas Use by Segment, Washington, 2015	33
Figure 3-10	Commercial Sector Natural Gas Use by End Use, Washington, 2015.....	33
Figure 3-11	Commercial Energy Usage Intensity by End Use and Segment, Washington, 2015 (Annual Therms/Sq. Ft)	34
Figure 3-12	Commercial Natural Gas Use by Segment, Idaho, 2015.....	36
Figure 3-13	Commercial Sector Natural Gas Use by End Use, Idaho, 2015	36
Figure 3-14	Commercial Energy Usage Intensity by End Use and Segment, Idaho, 2015 (Annual Therms/Sq. Ft).....	37
Figure 3-15	Industrial Natural Gas Use by End Use, Washington, 2015.....	38
Figure 3-16	Industrial Natural Gas Use by End Use, Idaho, 2015.....	40
Figure 4-1	Baseline Projection Summary by Sector, Washington (dekatherms)	42
Figure 4-2	Baseline Projection Summary by Sector, Idaho (dekatherms)	43
Figure 4-3	Residential Baseline Projection by End Use, Washington (dekatherms).....	44
Figure 4-4	Residential Baseline Projection by End Use, Idaho (dekatherms)	45
Figure 4-5	Commercial Baseline Projection by End Use, Washington (dekatherms).....	46
Figure 4-6	Commercial Baseline Projection by End Use, Idaho (dekatherms)	47
Figure 4-7	Industrial Baseline Projection by End Use, Washington (dekatherms).....	48
Figure 4-8	Industrial Baseline Projection by End Use, Idaho (dekatherms)	49
Figure 5-1	Summary of Energy Efficiency Potential as % of Baseline Projection, Washington (dekatherms).....	52
Figure 5-2	Baseline Projection and Energy Efficiency Forecasts, Washington (dekatherms) .	52
Figure 5-3	Cumulative UCT Achievable Economic Potential by Sector, Washington (% of Total)	53
Figure 5-4	Summary of Energy Efficiency Potential as % of Baseline Projection, Idaho (dekatherms).....	55
Figure 5-5	Summary of Energy Efficiency Potential as % of Baseline Projection, Idaho (dekatherms).....	55

Figure 5-6	Cumulative UCT Achievable Economic Potential by Sector, Idaho (% of Total) ..	56
Figure 6-1	Residential Energy Conservation by Case, Washington (dekatherms)	57
Figure 6-2	Residential UCT Achievable Economic Potential – Cumulative Savings by End Use, Washington (dekatherms, % of total).....	58
Figure 6-3	Residential Energy Conservation by Case, Idaho (dekatherms).....	61
Figure 6-4	Residential UCT Achievable Economic Potential – Cumulative Savings by End Use, Idaho (dekatherms, % of total)	62
Figure 6-5	Commercial Energy Conservation by Case, Washington (dekatherms).....	64
Figure 6-6	Commercial UCT Achievable Economic Potential – Cumulative Savings by End Use, Washington (dekatherms, % of total).....	65
Figure 6-7	Commercial Energy Conservation by Case, Idaho (dekatherms)	67
Figure 6-8	Commercial UCT Achievable Economic Potential – Cumulative Savings by End Use, Idaho (dekatherms, % of total)	68
Figure 6-9	Industrial Energy Conservation Potential, Washington (dekatherms).....	70
Figure 6-10	Industrial UCT Achievable Economic Potential – Cumulative Savings by End Use, Washington (dekatherms, % of total).....	71
Figure 6-11	Industrial Energy Conservation Potential, Idaho (dekatherms).....	73
Figure 6-12	Industrial UCT Achievable Economic Potential – Cumulative Savings by End Use, Idaho (dekatherms, % of total)	74

LIST OF TABLES

Table ES-1	Washington Conservation Potential by Case, Selected Years (dekatherms)	i
Table ES-2	Idaho Conservation Potential by Case, Selected Years (dekatherms)	ii
Table 1-1	Explanation of Abbreviations and Acronyms	4
Table 2-1	Overview of Avista Analysis Segmentation Scheme	9
Table 2-2	Example Equipment Measures for Direct Fuel Furnace – Single-Family Home, Washington	13
Table 2-3	Example Non-Equipment Measures – Existing Single Family Home, Washington ...	14
Table 2-4	Number of Measures Evaluated	14
Table 2-5	Data Applied for the Market Profiles	20
Table 2-6	Data Applied for the Baseline Projection in LoadMAP	21
Table 2-7	Residential Natural Gas Equipment Federal Standards	22
Table 2-8	Commercial and Industrial Natural Gas Equipment Standards	22
Table 2-9	Data Inputs for the Measure Characteristics in LoadMAP	23
Table 3-1	Avista Sector Control Totals, Washington, 2019	25
Table 3-2	Avista Sector Control Totals, Idaho, 2019	26
Table 3-3	Residential Sector Control Totals, Washington, 2019	27
Table 3-4	Average Market Profile for the Residential Sector, Washington, 2019	29
Table 3-5	Residential Sector Control Totals, Idaho, 2019	29
Table 3-6	Average Market Profile for the Residential Sector, 2019	31
Table 3-7	Commercial Sector Control Totals, Washington, 2019	32
Table 3-8	Average Market Profile for the Commercial Sector, Washington, 2019	34
Table 3-9	Commercial Sector Control Totals, Idaho, 2019	35
Table 3-10	Average Market Profile for the Commercial Sector, Idaho, 2019	37
Table 3-11	Industrial Sector Control Totals, Washington, 2019	38
Table 3-12	Average Natural Gas Market Profile for the Industrial Sector, Washington, 2019 .	39
Table 3-13	Industrial Sector Control Totals, Idaho, 2019	39
Table 3-14	Average Natural Gas Market Profile for the Industrial Sector, Idaho, 2019	40
Table 4-1	Baseline Projection Summary by Sector, Washington, Selected Years (dekatherms)	42
Table 4-2	Baseline Projection Summary by Sector, Idaho, Selected Years (dekatherms)	43
Table 4-3	Residential Baseline Projection by End Use, Washington (dekatherms)	44
Table 4-4	Residential Baseline Projection by End Use, Idaho (dekatherms)	45
Table 4-5	Commercial Baseline Projection by End Use, Washington (dekatherms)	46
Table 4-6	Commercial Baseline Projection by End Use, Idaho (dekatherms)	47
Table 4-7	Industrial Baseline Projection by End Use, Washington (dekatherms)	48
Table 4-8	Industrial Baseline Projection by End Use, Idaho (dekatherms)	49
Table 5-1	Summary of Energy Efficiency Potential, Washington (dekatherms)	51
Table 5-2	Cumulative UCT Achievable Economic Potential by Sector, Washington, Selected Years (dekatherms)	53
Table 5-3	Summary of Energy Efficiency Potential, Idaho (dekatherms)	54

Table 5-4	Cumulative UCT Achievable Economic Potential by Sector, Idaho, Selected Years (dekatherms).....	56
Table 6-1	Residential Energy Conservation Potential Summary, Washington (dekatherms) .	57
Table 6-2	Residential Top Measures in 2021 and 2022, UCT Achievable Economic Potential, Washington (dekatherms)	60
Table 6-3	Residential Energy Conservation Potential Summary, Idaho (dekatherms)	61
Table 6-4	Residential Top Measures in 2021 and 2022, UCT Achievable Economic Potential, Idaho (dekatherms)	63
Table 6-5	Commercial Energy Conservation Potential Summary, Washington	64
Table 6-6	Commercial Top Measures in 2021 and 2022, UCT Achievable Economic Potential, Washington (dekatherms)	66
Table 6-7	Commercial Energy Conservation Potential Summary, Idaho.....	67
Table 6-8	Commercial Top Measures in 2021 and 2022, UCT Achievable Economic Potential, Idaho (dekatherms)	69
Table 6-9	Industrial Energy Conservation Potential Summary, Washington (dekatherms) ...	70
Table 6-10	Industrial Top Measures in 2021 and 2022, UCT Achievable Economic Potential, Washington (dekatherms)	72
Table 6-11	Industrial Energy Conservation Potential Summary, Idaho (dekatherms)	73
Table 6-12	Industrial Top Measures in 2018 and 2019, UCT Achievable Economic Potential, Idaho (dekatherms).....	75
Table 7-1	Comparison of Avista's Washington Residential Programs with 2018 UCT Achievable Economic Potential (dekatherms).....	77
Table 7-2	Comparison of Avista's Washington Nonresidential Accomplishments with 2021 UCT Achievable Economic Potential (dekatherms)	78
Table 7-3	Comparison of Avista's Idaho Residential Programs with 2021 UCT Achievable Economic Potential (dekatherms).....	79
Table 7-4	Comparison of Avista's Idaho Nonresidential Accomplishments with 2021 UCT Achievable Economic Potential (dekatherms)	80
Table 8-1	Comparison of Avista's Residential UCT Achievable Economic Potential between the 2016 and 2018 CPAs (dekatherms).....	81
Table 8-2	Comparison of Avista's Nonresidential UCT Achievable Economic Potential between the 2016 and 2018 CPAs (dekatherms)	82

1

INTRODUCTION

This report documents the results of the Avista Utilities 2021-2040 Conservation Potential Assessment (CPA) as well as the steps followed in its completion. Throughout this study, AEG worked with Avista to understand the baseline characteristics of their service territory, including a detailed understanding of energy consumption in the territory, the assumptions and methodologies used in Avista's official load forecast, and recent programmatic accomplishments. Adapting methodologies consistent with the Northwest Power and Conservation Council's (Council's) 2021 Power Plan¹ for natural gas studies, AEG then developed an independent estimate of achievable, cost-effective EE potential within Avista's service territory between 2021 and 2040.

Goals of the Conservation Potential Assessment

The first primary objective of this study was to develop independent and credible estimates of EE potential achievable within Avista's service territory using accepted regional inputs and methodologies. This included estimating technical, *achievable* technical, then achievable *economic* potential, using the Council's ramp rates as the starting point for all achievability assumptions, leveraging Northwest Energy Efficiency Alliance's (NEEA's) market research initiatives, and utilizing assumptions consistent with 2021 Power Plan supply curves and RTF measure workbooks when appropriate for use in natural gas planning studies.

Additionally, the CPA is intended to support the design of programs to be implemented by Avista during the upcoming years. One output of the LoadMAP model is a comprehensive summary of measures. This summary documents input assumptions and sources on a per-unit value, program applicability and achievability (ramp rates), and potential results (units, incremental potential, and cumulative potential) as well as cost-effectiveness at the UCT and TRC levels. This summary was developed in collaboration with Avista and refined throughout the project.

Finally, this study was developed to provide EE inputs into Avista's Integrated Resource Planning (IRP) process. To this end, AEG developed detailed achievable economic EE inputs by measure for input into Avista's SENDOUT planning model under the utility cost test (UCT). These inputs are highly customizable and provide potential estimates at the state level by measure and end use. We present a map of Avista's service territory in Figure 1-1.

¹ "2021 Power Plan. Northwest Power & Conservation Council, 2020. <https://www.nwcouncil.org/2021-northwest-power-plan>

Figure 1-1 Avista's Service Territory (courtesy Avista)



Summary of Report Contents

The document is divided into seven additional chapters, summarizing the approach, assumptions, and results of the EE potential analysis. We describe each section below:

Volume 1, Final Report:

- **Analysis Approach and Data Development.** Detailed description of AEG's approach to conducting Avista's 2021-2040 Natural Gas CPA and documentation of primary and secondary sources used.
- **Market Characterization and Market Profiles.** Characterization of Avista's service territory in the base year of the study, 2019, including total consumption, number of customers and market units, and energy intensity. This also includes a breakdown of the energy consumption for residential, commercial, and eligible industrial customers by end use and technology.
- **Baseline Projection.** Projection of baseline energy consumption under a naturally occurring efficiency case, described at the end-use level. The LoadMAP models were first aligned with actual sales and Avista's official, weather-normalized econometric forecast and then varied to include the impacts of future federal standards, ongoing impacts of energy codes, such as the 2015 Washington State Energy Code on new construction, and future technology purchasing decisions.
- **Overall Energy Efficiency Potential.** Summary of EE potential for Avista's Washington and Idaho service territories for selected years between 2021 and 2040.
- **Sector-Level Energy Efficiency Potential.** Summary of EE potential for each market sector within Avista's service territory, including residential, commercial, and eligible industrial customers for both

Washington and Idaho. This section includes a more detailed breakdown of potential by measure type, vintage, market segment, end use, and state.

- Comparison with Current Programs Detailed comparison of potential with current Avista programs, including new opportunities for potential.
- Comparison with 2018 CPA Detailed comparison of potential with Avista's 2018 CPA, conducted by AEG.

Volume 2, Appendices:

The appendices for this report are provided in separate spreadsheets accompanying delivery of this report and consist of the following:

- Market Profiles. Detailed market profiles for each market segment. Includes equipment saturation, unit energy consumption or energy usage index, energy intensity, and total consumption.
- Customer Adoption Factors. Documentation of the ramp rates used in this analysis. These were adapted from the 2021 Power Plan electrical power conservation supply curve workbooks for use in the estimation of achievable natural gas potential.
- Measure List. List of measures, along with example baseline definitions and efficiency options by market sector analyzed.
- Detailed Measure Assumptions. This dataset provides input assumptions, measure characteristics, cost-effectiveness results, and potential estimates for each measure permutation analyzed within the study.

Abbreviations and Acronyms

Throughout the report we use several abbreviations and acronyms. Table 1-1 shows the abbreviation or acronym, along with an explanation.

Table 1-1 *Explanation of Abbreviations and Acronyms*

Acronym	Explanation
AEO	Annual Energy Outlook forecast developed by EIA
B/C Ratio	Benefit to Cost Ratio
BEST	AEG's Building Energy Simulation Tool
BPA	Bonneville Power Administration
C&I	Commercial and Industrial
CBSA	NEEA's 2019 Commercial Building Stock Assessment
Council	Northwest Power and Conservation Council (NWPPCC)
DHW	Domestic Hot Water
DSM	Demand Side Management
EE	Energy Efficiency
EIA	Energy Information Administration
EUL	Estimated Useful Life
EUI	Energy Usage Intensity
HVAC	Heating Ventilation and Air Conditioning
IFSA	NEEA's 2014 Industrial Facilities Site Assessment
IRP	Integrated Resource Plan
LoadMAP	AEG's Load Management Analysis and Planning™ tool
NEEA	Northwest Energy Efficiency Alliance
O&M	Operations and Maintenance
RBSA	NEEA's 2016 Residential Building Stock Assessment
RTF	Regional Technical Forum
RVT	Resource Value Test
TRC	Total Resource Cost test
UCT	Utility Cost Test
UEC	Unit Energy Consumption
UES	Unit Energy Savings
WSEC	2015 Washington State Energy Code

2

ANALYSIS APPROACH AND DATA DEVELOPMENT

This section describes the analysis approach taken for the study and the data sources used to develop the potential estimates.

Overview of Analysis Approach

To perform the potential analysis, AEG used a bottom-up approach following the major steps listed below. We describe these analysis steps in more detail throughout the remainder of this chapter.

1. Performed a market characterization to describe sector-level natural gas use for the residential, commercial, and industrial sectors for the base year, 2019. This included extensive use of Avista data and other secondary data sources from NEEA and the Energy Information Administration (EIA).
2. Developed a baseline projection of energy consumption by sector, segment, end use, and technology for 2021 through 2040.
3. Defined and characterized several hundred EE measures to be applied to all sectors, segments, and end uses.
4. Estimated technical, achievable technical, and achievable economic energy savings at the measure level for 2021-2040. Achievable economic potential was assessed using both the UCT and TRC screens.

Comparison with Northwest Power & Conservation Council Methodology

It is important to note the Council's methodology was developed for, and used, in electric CPAs. Natural gas impacts are typically assessed when they overlap with electricity measures (e.g. gas water heating impacts in an electrically heated "Built Green Washington" home). The Council's ramp rates were also developed with electric utility DSM programs in mind. Electricity is the primary focus of the regionwide potential assessed in the Council's Plans. Although Avista is a dual-fuel utility, this study focuses on natural gas measures and programs, which exhibit noticeable differences from electric programs, notably regarding avoided costs. To account for this, AEG adapted Council methodologies in some cases, rather than using them directly from the source. This is especially relevant in the development of ramp rates when achievability was determined to not be applicable to a specific natural gas measure or program. We discuss this in Section 7 of this report.

A primary objective of the study was to estimate natural gas potential consistent with the Northwest Power & Conservation Council's (NWPCC) analytical methodologies and procedures for electric utilities. While developing Avista's 2021-2040 CPA, the AEG team relied on an approach vetted and adapted through the successful completion of CPAs under the Council's Fifth, Sixth, Seventh, and now 2021 Power Plans. Among other aspects, this approach involves using consistent:

- Data sources: Avista surveys, regional surveys, market research, and assumptions
- Measures and assumptions: Avista TRM, Seventh Plan supply curves and RTF work products
- Potential factors: 2021 Power Plan ramp rates
- Levels of potential: technical, achievable technical, and achievable economic

- Cost-effectiveness approaches: assessed potential under the UCT as well as Council's TRC method, including non-energy impacts (and non-gas energy impacts) which may be quantified and monetized as well as O&M impacts within the TRC
- Conservation credits: applied a 10% conservation credit to avoided energy costs for energy benefits was applied to the TRC calculation

LoadMAP Model

For this analysis, AEG used its Load Management Analysis and Planning tool (LoadMAP™) version 5.0 to develop both the baseline projection and the estimates of potential. AEG developed LoadMAP in 2007 and has enhanced it over time, using it for the EPRI National Potential Study and numerous utility-specific forecasting and potential studies since. Built in Excel, the LoadMAP framework (see Figure 2-1) is both accessible and transparent and has the following key features.

- Embodies the basic principles of rigorous end-use models (such as EPRI's Residential End-Use Energy Planning System (REEPS) and Commercial End-Use Planning System (COMMEND)) but in a more simplified, accessible form.
- Includes stock-accounting algorithms that treat older, less efficient appliance/equipment stock separately from newer, more efficient equipment. Equipment is replaced according to the measure life and appliance vintage distributions defined by the user.
- Balances the competing needs of simplicity and robustness by incorporating important modeling details related to equipment saturations, efficiencies, vintage, and the like, where market data are available, and treats end uses separately to account for varying importance and availability of data resources.
- Isolates new construction from existing equipment and buildings and treats purchase decisions for new construction and existing buildings separately. This is especially relevant in the state of Washington where the 2015 WSEC substantially enhances the efficiency of the new construction market.
- Uses a simple logic for appliance and equipment decisions. Other models available for this purpose embody complex customer choice algorithms or diffusion assumptions, and the model parameters tend to be difficult to estimate or observe and sometimes produce anomalous results that require calibration or even overriding. The LoadMAP approach allows the user to drive the appliance and equipment choices year by year directly in the model. This flexible approach allows users to import the results from diffusion models or to input individual assumptions. The framework also facilitates sensitivity analysis.
- Includes appliance and equipment models customized by end use. For example, the logic for water heating is distinct from furnaces and fireplaces.
- Can accommodate various levels of segmentation. Analysis can be performed at the sector level (e.g., total residential) or for customized segments within sectors (e.g., housing type, state, or income level).
- Natively outputs model results in a detailed line-by-line summary file, allowing for review of input assumptions, cost-effectiveness results, and potential estimates at a granular level. Also allows for the development of IRP supply curves, both at the achievable technical and achievable economic potential levels.

- Consistent with the segmentation scheme and the market profiles we describe below, the LoadMAP model provides projections of baseline energy use by sector, segment, end use, and technology for existing and new buildings. It also provides forecasts of total energy use and energy-efficiency savings associated with the various types of potential.²

Figure 2-1 LoadMAP Analysis Framework

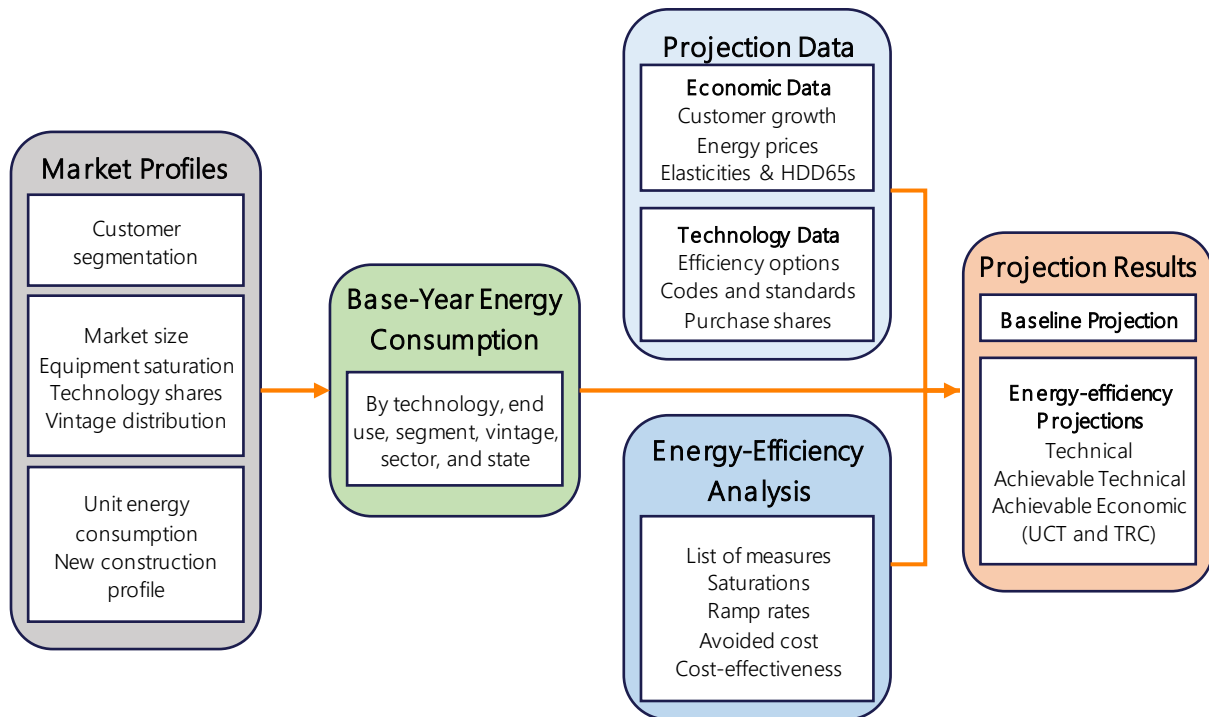

Definitions of Potential

Before we delve into the details of the analysis approach, it is important to define what we mean when discussing energy efficiency (EE) potential. In this study, the savings estimates are developed for three types of potential: technical potential, economic potential, and achievable potential. These are developed at the measure level, and results are provided as savings impacts over the 20-year forecasting horizon. The various levels are described below.

- Technical Potential is defined as the *theoretical* upper limit of EE potential. It assumes customers adopt all feasible measures regardless of their cost. At the time of existing equipment failure, customers replace their equipment with the most efficient option available. In new construction, customers and developers also choose the most efficient equipment option.
 - Technical potential also assumes the adoption of every other available measure, where technically feasible. For example, it includes installation of high-efficiency windows in all new construction opportunities and furnace maintenance in all existing buildings with installed furnaces. These retrofit measures are phased in over a number of years to align with the stock turnover of related equipment units, rather than modeled as immediately available all at once.

² The model computes energy forecasts for each type of potential for each end use as an intermediate calculation. Annual-energy savings are calculated as the difference between the value in the baseline projection and the value in the potential forecast (e.g., the technical potential forecast).

- Achievable Technical Potential refines technical potential by applying customer participation rates that account for market barriers, customer awareness and attitudes, program maturity, and other factors that affect market penetration of conservation measures. The customer adoption rates used in this study were the ramp rates developed for the Northwest Power & Conservation Council's Seventh Plan based on the electric-utility model, tailored for use in natural gas EE programs.
- UCT Achievable Economic Potential further refines achievable technical potential by applying an economic cost-effectiveness screen. In this analysis, primary cost-effectiveness is measured by the utility cost test (UCT), which assesses cost-effectiveness from the utility's perspective. This test compares lifetime energy benefits to the costs of delivering the measure through a utility program, excluding monetized non-energy impacts. These costs are the incentive, as a percent of incremental cost of the given efficiency measure, relative to the relevant baseline course of action (e.g. federal standard for lost opportunity and no action for retrofits), plus any administrative costs that are incurred by the program to deliver and implement the measure. If the benefits outweigh the costs (that is, if the UCT ratio is greater than 1.0), a given measure is included in the economic potential.
- TRC Achievable Economic Potential is similar to UCT achievable economic potential in that it refines achievable technical potential through cost-effectiveness analysis. The total resource cost (TRC) test assesses cost-effectiveness from a combined utility and participant perspective. As such, this test includes full measure costs but also includes non-energy impacts realized by the customer if quantifiable and monetized. In addition to non-energy impacts, we assessed the impacts of non-gas savings following Council methodology. This includes a calibration credit for space heating equipment consumption to account for secondary heating equipment present in an average home as well as other electric end-use impacts such as cooling and interior lighting as applicable on a measure-by-measure basis. As a secondary screen, we include TRC results for comparative purposes.

Market Characterization

Now that we have described the modeling tool and provided the definitions of the potential cases, the first step in the actual analysis approach is market characterization. To estimate the savings potential from energy-efficient measures, it is necessary to understand how much energy is used today and what equipment is currently in service. This characterization begins with a segmentation of Avista's natural gas footprint to quantify energy use by sector, segment, end-use application, and the current set of technologies in use. For this we rely primarily on information from Avista, augmenting with secondary sources as necessary.

Segmentation for Modeling Purposes

This assessment first defined the market segments (states, building types, end uses, and other dimensions) that are relevant in Avista's service territory. The segmentation scheme for this project is presented in Table 2-1.

Table 2-1 Overview of Avista Analysis Segmentation Scheme

Dimension	Segmentation Variable	Description
0	State	Washington and Idaho
1	Sector	Residential, Commercial, Industrial
2	Segment	Residential: Single Family, Multifamily, Mobile Home, Low Income Commercial: Office, Restaurant, Retail, Grocery, School, College, Health, Lodging, Warehouse, Miscellaneous Industrial
3	Vintage	Existing and new construction
4	End uses	Heating, secondary heating, water heating, food preparation, process, and miscellaneous (as appropriate by sector)
5	Appliances/end uses and technologies	Technologies such as furnaces, water heaters, and process heating by application, etc.
6	Equipment efficiency levels for new purchases	Baseline and higher-efficiency options as appropriate for each technology

With the segmentation scheme defined, we then performed a high-level market characterization of natural gas sales in the base year, 2019. This information provided control totals at a sector level for calibrating the LoadMAP model to known data for the base-year.

Market Profiles

The next step was to develop market profiles for each sector, customer segment, end use, and technology. A market profile includes the following elements:

- Market size is a representation of the number of customers in the segment. For the residential sector, the unit we use is number of households. In the commercial sector, it is floor space measured in square feet. For the industrial sector, it is number of employees.
- Saturations indicate the share of the market that is served by a particular end-use technology. Three types of saturation definitions are commonly used:

- The conditioned space approach accounts for the fraction of each building that is conditioned by the end use. This applies to cooling and heating end uses.
- The whole-building approach measures shares of space in a building with an end use regardless of the portion of each building that is served by the end use. Examples are commercial refrigeration and food service, and domestic water heating and appliances.
- The 100% saturation approach applies to end uses that are generally present in every building or home and are simply set to 100% in the base year.
- UEC (Unit Energy Consumption) or EUI (Energy Usage Index) define consumption for a given technology. UEC represents the amount of energy a given piece of equipment is expected to use in one year. EUI is a UEC indexed to a non-building market unit, such as per square foot or per employee)
- These are indices that refer to a measure of average annual energy use per market unit (home, floor space, or employee in the residential, commercial, and industrial sector, respectively) that are served by an end-use technology. UECs and EUIs embody an average level of service and average equipment efficiency for the market segment.
- Annual energy intensity for the residential sector represents the average energy use for the technology across all homes in 2015. It is computed as the product of the saturation and the UEC and is defined as therms/household for natural gas. For the commercial and industrial sectors, intensity, computed as the product of the saturation and the EUI, represents the average use for the technology across all floor space or all employees in the base year.
- Annual usage is the annual energy used by each end-use technology in the segment. It is the product of the market size and intensity and is quantified in therms or dekatherms.

The market characterization results and the market profiles are presented in Section 3 and Appendix A.

Baseline Projection

The next step was to develop the baseline projection of annual natural gas use for 2021 through 2040 by customer segment and end use in the absence of new utility energy efficiency programs.

We first aligned with Avista's official forecast. AEG incorporated assumptions and data utilized in the official utility forecast. Avista's heating degree days (base 65°F) were incorporated into the LoadMAP model to align the baseline projection with the official utility forecast. We calibrated to actual sales when available.

The end-use projection includes impacts of future federal standards that were effective as of December 2017, which drive energy consumption down through the study period.

Naturally occurring energy conservation, that is, energy conservation that is realized within the service area independent of utility-sponsored programs, is incorporated into the baseline projection consistent with the US Energy Information Administration's Annual Energy Outlook for the Pacific region. Results of the primary market research were used to calibrate these assumptions to ensure the secondary sources were relevant to Avista customers. For example, some customers will purchase and install energy conservation measures that are available in the market without a utility incentive.

As such, the baseline projection is the foundation for the analysis of savings in future conservation cases and scenarios as well as the metric against which potential savings are measured.

Inputs to the baseline projection include:

- Current economic growth forecasts (i.e., customer growth, changes in weather (Heating Degree Day, base-65°F (HDD65) normalization))
- Trends in fuel shares and equipment saturations
- Existing and approved changes to building codes and equipment standards

We present the baseline projection results for the system as a whole, and for each sector in Section 4.

Energy Efficiency Measure Development

This section describes the framework used to assess the savings, costs, and other attributes of energy efficiency measures. These characteristics form the basis for measure-level cost-effectiveness analyses as well as for determining measure-level savings. For all measures, AEG assembled information to reflect equipment performance, incremental costs, and equipment lifetimes. This information combined with Avista's avoided cost data informs the economic screens that determine economically feasible measures. In this section, AEG would like to acknowledge the work of the Avista team in detailed measure assumptions specific to the territory and region within the Avista TRM, which was provided at the outset of this study.

Figure 2-2 outlines the framework for measure characterization analysis. First, the list of measures is identified; each measure is then assigned an applicability for each market sector and segment and characterized with appropriate savings, costs and other attributes; then the cost-effectiveness screening is performed. Avista provided feedback during each step of the process to ensure measure assumptions and results lined up with programmatic experience.

We compiled a robust list of conservation measures for each customer sector, drawing upon Avista's TRM and program experience, AEG's own measure databases and building simulation models, and secondary sources, primarily the Regional Technical Forum's (RTF) UES measure workbooks and the Seventh Plan's electric power conservation supply curves. This universal list of measures covers all major types of end-use equipment, as well as devices and actions to reduce energy consumption.

Figure 2-2 Approach for ECM Assessment

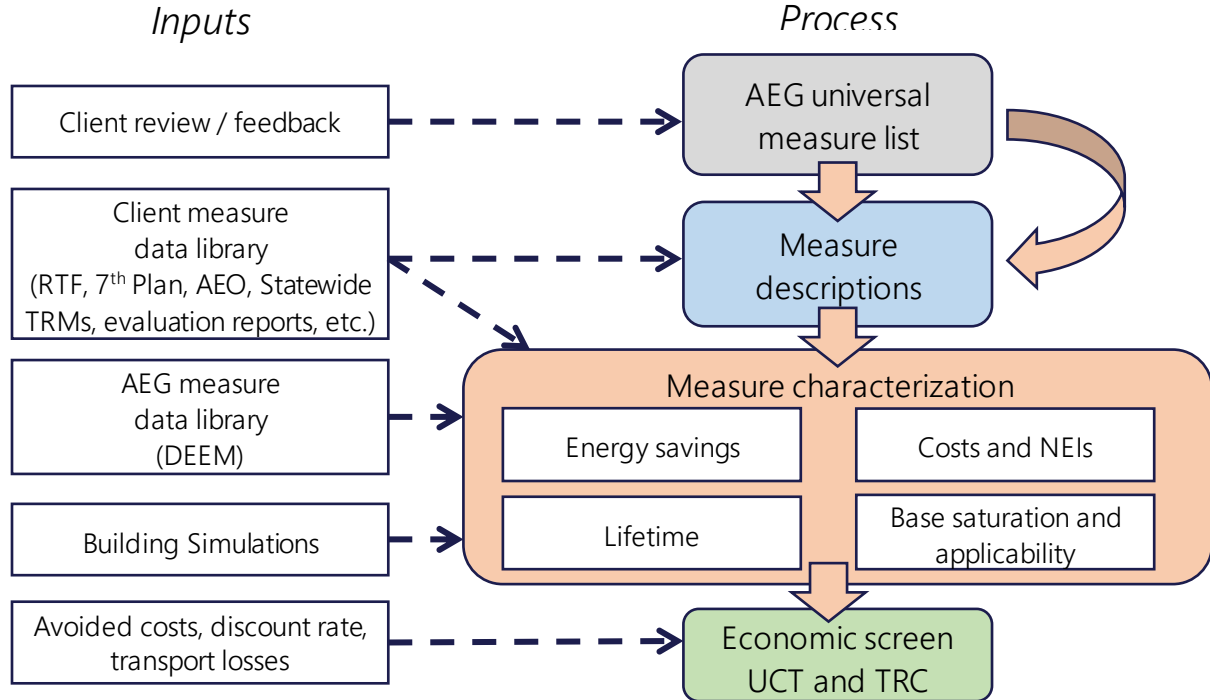

The selected measures are categorized into two types according to the LoadMAP modeling taxonomy: equipment measures and non-equipment measures.

- Equipment measures are efficient energy-consuming pieces of equipment that save energy by providing the same service with a lower energy requirement than a standard unit. An example is an ENERGY STAR® residential water heater (UEF 0.64) that replaces a standard efficiency water heater (UEF 0.58). For equipment measures, many efficiency levels may be available for a given technology, ranging from the baseline unit (often determined by a code or standard) up to the most efficient product commercially available. These measures are applied on a stock-turnover basis, and in general, are referred to as lost opportunity (LO) measures by the Council because once a purchase decision is made, there will not be another opportunity to improve the efficiency of that equipment item until its effective useful life (EUL) is reached once again.
- Non-equipment measures save energy by reducing the need for delivered energy, but do not necessarily involve replacement or purchase of major end-use equipment (such as a furnace or water heater). Measure installation is not tied to a piece of equipment reaching end of useful life, so these are generally categorized as “retrofit” measures. An example would be low-flow showerheads that modify a household’s hot water consumption. The existing showerheads can be achievable replaced without waiting for the existing showerhead to malfunction, and saves energy used by the water heating equipment. Non-equipment measures typically fall into one of the following categories:
 - Building shell (windows, insulation, roofing material)
 - Equipment controls (smart thermostats, water heater setback)
 - Whole-building design (ENERGY STAR homes)

- o Retrocommissioning and strategic energy management

We developed a preliminary list of efficient measures, which was distributed to Avista’s project team for review. Once we assembled the list of measures, the AEG team assessed their energy-saving characteristics. For each measure, we also characterized incremental cost, service life, non-energy impacts, and other performance factors. Following the measure characterization, we performed an economic screening of each measure, which serves as the basis for developing the economic and achievable potential scenarios.

Representative Measure Data Inputs

To provide an example of measure data, Table 2-2 and Table 2-3 present examples of the detailed data inputs behind both equipment and non-equipment measures, respectively, for the case of residential direct-fuel furnaces in single-family homes in Washington. Table 2-2 displays the various efficiency levels available as equipment measures, as well as the corresponding effective useful life, energy usage, and cost estimates. The columns labeled “On Market” and “Off Market” reflect equipment availability due to codes and standards or the entry of new products to the market.

Table 2-2 Example Equipment Measures for Direct Fuel Furnace – Single-Family Home, Washington

Efficiency Level	Useful Life (years)	Equipment Cost	Energy Usage (therms/yr)	On Market	Off Market
AFUE 80%	20	\$1,955	517	2019	2023
AFUE 90%	20	\$2,058	465	2019	2023
AFUE 92%	20	\$2,099	453	2019	n/a
AFUE 95%	20	\$2,778	438	2019	n/a
AFUE 98%	20	\$3,035	423	2019	n/a
Convert to NG Heat Pump	20	\$6,739	345	2019	n/a

Table 2-3 lists some of the non-equipment measures applicable to a direct-fuel furnace in an existing single-family home. All measures are evaluated for cost effectiveness based on the lifetime benefits relative to the cost of the measure. The total savings, costs, and monetized non-energy impacts are calculated for each year of the study and depend on the base year saturation of the measure, the applicability of the measure, and the savings as a percentage of the relevant energy end uses. We model two flavors of most shell insulations measures. The first is the installation of insulation where there is none (or very little). This applies to a small subset of the population (roughly 7% of the population is eligible for this measure per RBSA 2016) but has large savings impacts. This percentage is low due to the impacts of current Avista programs, strict Washington building codes, and naturally occurring efficiency. The second is an insulation upgrade measure where homes with existing insulation below the threshold but not classified as no insulation, may be upgraded to higher R-values. This applies to a much larger percentage of the market.

Table 2-3 Example Non-Equipment Measures – Existing Single Family Home, Washington³

End Use	Measure	Saturation in 2019 ⁴	Applicability	Lifetime (yrs)	Measure Installed Cost	Energy Savings (%)
Heating	Insulation - Ceiling Installation	0%	7%	45	\$1,280	31.3%
Heating	Insulation – Ceiling Upgrade	78%	87%	45	\$1,739	1.2%
Heating	Ducting Repair and Sealing	20%	50%	20	\$794	6.0%
Heating	Windows - High Efficiency ⁵	0%	25%	45	\$5,337	25.5%

Table 2-4 summarizes the number of measures evaluated for each segment within each sector.

Table 2-4 Number of Measures Evaluated

Sector	Total Measures	Measure Permutations w/ 2 Vintages	Measure Permutations w/ All Segments & States
Residential	46	92	736
Commercial	51	102	2,040
Industrial	30	60	120
Total Measures Evaluated	127	254	2,896

Calculation of Energy Conservation Potential

The approach we used for this study to calculate the energy conservation potential adheres to the approaches and conventions outlined in the National Action Plan for Energy-Efficiency (NAPEE) Guide for Conducting Potential Studies.⁶ This document represents credible and comprehensive industry best practices for specifying energy conservation potential. Three types of potential were developed as part of this effort: technical potential, achievable technical potential, and achievable economic potential (using UCT and TRC). The calculation of technical potential is a straightforward algorithm which, as described above, assumes that customers adopt all feasible measures regardless of their cost.

Stacking of Measures and Interactive Effects

An important factor when estimating potential is to consider interactions between measures when they are applied within the same space. This is important to avoid double counting and could feasibly result in savings at greater than 100% of equipment consumption if not properly accounted for.

This occurs at the population or system level, where multiple DSM actions must be stacked or layered on top of each other in succession, rather than simply summed arithmetically. These interactions are automatically handled within the LoadMAP models where measure impacts are stacked on top of each

³ The applicability factors consider whether the measure is applicable to a particular building type and whether it is feasible to install the measure. For instance, duct repair and sealing is not applicable to homes with zonal heating systems since there is no ductwork present to repair.

⁴ Note that saturation levels reflected increase from their base year saturation as more measures are adopted.

⁵ The RTF has increased the efficiency requirements for what is considered a "high efficiency" window for the purpose of future programs. As a result, no respondents to the 2016 RBSA have windows that already meet this threshold. However, the qualified savings in the RTF workbook require a certain level of *inefficiency* in the pre-existing window to be eligible. The 25% applicability reflects the population that is eligible to participate.

⁶ National Action Plan for Energy Efficiency (2007). *National Action Plan for Energy Efficiency Vision for 2025: Developing a Framework for Change*. www.epa.gov/eeactionplan.

other, modifying the baseline for each subsequent measure. We first compute the total savings of each measure on a standalone basis, then also assign a stacking priority, based on levelized cost, to the measures such that “integrated” or “stacked” savings will be calculated as a percent reduction to the running total of baseline energy remaining in each end use after the previous measures have been applied. This ensures that the available pie of baseline energy shrinks in proportion to the number of DSM measures applied, as it would in reality. The loading order is based on the levelized cost of conserved energy, such that the more economical measures that are more likely to be selected from a resource planning perspective will be the first to be applied to the modeled population.

We also account for exclusivity of certain measure options when defining measure assumptions. For instance, if an AFUE 95% furnace is installed in a single-family home, the model will not allow that same home to install an AFUE 98% furnace, or any other furnace, until the newly installed AFUE 95% option has reached its end of useful life. For non-equipment measures, which do not have a native applicability limit, we define base saturations and applicabilities such that measures do not overlap. For example, we model two flavors of ceiling insulation. The first assumes the installation of insulation where there previously was none. The second upgrades pre-existing insulation if it falls under a certain threshold. We used regional market research data to ensure exclusivity of these two options. NEEA's 2014 RBSA contains information on average R-values of insulation installed. The AEG team used this data to define the percent of homes that could install one measure, but not the other.

Estimating Customer Adoption

Once the technical potential is established, estimates for the market adoption rates for each measure are applied that specify the percentage of customers that will select the highest-efficiency economic option. This phases potential in over a more realistic time frame that considers barriers such as imperfect information, supplier constraints, technology availability, and individual customer preferences. The intent of market adoption rates is to establish a path to full market maturity for each measure or technology group and ensure resource planning does not overstep acquisition capabilities. We adapted the Northwest Power and Conservation Council's 2021 Plan ramp rates to develop these achievability factors for each measure. Applying these ramp rates as factors leads directly to the achievable technical potential.

Screening Measures for Cost-Effectiveness

With achievable technical potential established, the final step is to apply an economic screen and arrive at the subset of measures that are cost-effective and ultimately included in achievable economic potential.

LoadMAP performs an economic screen for each individual measure in each year of the planning horizon. This study uses the UCT test as the primary cost-effectiveness metric, which compares the lifetime hourly energy benefits of each applicable measure with the incentive and administrative costs incurred by the utility. The lifetime benefits are calculated by multiplying the annual energy savings for each measure by Avista's avoided costs and discounting the dollar savings to the present value equivalent. Lifetime costs represent incremental measure cost. The analysis uses each measure's values for savings, costs, and lifetimes that were developed as part of the measure characterization process described above.

The LoadMAP model performs this screening dynamically, considering changing savings and cost data over time. Thus, some measures pass the economic screen for some, but not all, of the years in the forecast.

It is important to note the following about the economic screen:

- The economic evaluation of every measure in the screen is conducted relative to a baseline condition. For instance, in order to determine the therm savings potential of a measure, consumption with the measure applied must be compared to the consumption of a baseline condition.
- The economic screening was conducted only for measures that are applicable to each building type and vintage; thus, if a measure is deemed to be irrelevant to a building type and vintage, it is excluded from the respective economic screen.

This constitutes the achievable economic potential and includes every program-ready opportunity for conservation savings. Potential results are presented in Sections 4 and 5. Measure-level detail is available as a separate appendix to this report.

Data Development

This section details the data sources used in this study, followed by a discussion of how these sources were applied. In general, data were adapted to local conditions, for example, by using local sources for measure data and local weather for building simulations.

Data Sources

The data sources are organized into the following categories:

- Avista-provided data
- AEG's databases and analysis tools
- Other secondary data and reports

Avista Data

Our highest priority data sources for this study were those that were specific to Avista, including the primary market research conducted specifically for this study. This data is specific to Avista's service territory and is an important consideration when customizing the model for Avista's market. This is best practice when developing CPA baselines when the data is available.

- Avista customer account database. Avista provided billing data for development of customer counts and energy use for each sector. This included a very detailed database of customer building classifications which was instrumental in the development of segmentation.
- Avista's 2013 GenPOP Residential Survey. In 2013, Avista hired The Cadmus Group to conduct a residential saturation survey, which included results from 1,051 customers. The results of this survey helped segment the residential sector and establish fuel and technology shares for the base year. This data was very useful in developing a detailed estimate of energy consumption within Avista's service territory.
- Load forecasts. Avista provided forecasts, by sector and state, of energy consumption, customer counts, weather actuals for 2015 and 2017, as well as weather-normal HDD65s.
- Economic information. Avista provided a discount rate as well as avoided cost forecasts consistent with those utilized in the IRP.
- Avista program data. Avista provided information about past and current programs, including program descriptions, goals, and measure achievements to date.

- Avista TRM. Avista provided a documented list of energy conservation measures and assumptions considered within current programs. We utilized this as a primary source of measure information, supplemented by Northwest data, AEG data, and secondary data as described below.

Northwest Regional Data

The study utilized a variety of local data and research, including research performed by the Northwest Energy Efficiency Alliance (NEEA) and analyses conducted by the Council. Most important among these are:

- Northwest Power and Conservation Council, 2021 Power Plan and Regional Technical Forum workbooks. To develop its Power Plan, the Council maintains workbooks with detailed information about measures. This was used as a primary data source when Avista-specific program data was not available, and the data was determined to be applicable to natural gas conservation measures. The most recent data and workbooks available were used at the time of this study.
 - <https://www.nwcouncil.org/2021-northwest-power-plan>
 - <https://rtf.nwcouncil.org/measures>
- Northwest Energy Efficiency Alliance, 2011 Residential Building Stock Assessment Single-Family, Market Research Report, <http://neea.org/docs/reports/residential-building-stock-assessment-single-family-characteristics-and-energy-use.pdf?sfvrsn=8>
- Northwest Energy Efficiency Alliance, 2014 Commercial Building Stock Assessment, December 16, 2014, http://neea.org/docs/default-source/reports/2014-cbsa-final-report_05-dec-2014.pdf?sfvrsn=12.
- Northwest Energy Efficiency Alliance, 2014 Industrial Facilities Site Assessment, December 29, 2014, <http://neea.org/resource-center/regional-data-resources/industrial-facilities-site-assessment>

Since Avista's GenPOP survey contained detailed appliance saturations, the RBSA was used more for benchmarking and comparative purposes, rather than as a primary source of data. The NEEA surveys were used extensively to develop base saturation and applicability assumptions for many of the non-equipment measures within the study.

AEG Data

AEG maintains several databases and modeling tools that we use for forecasting and potential studies. Relevant data from these tools has been incorporated into the analysis and deliverables for this study.

- AEG Energy Market Profiles. For more than 10 years, AEG staff has maintained profiles of end-use consumption for the residential, commercial, and industrial sectors. These profiles include market size, fuel shares, unit consumption estimates, and annual energy use by fuel (natural gas and electricity), customer segment and end use for 10 regions in the U.S. The Energy Information Administration surveys (RECS, CBECS and MECS) as well as state-level statistics and local customer research provide the foundation for these regional profiles.
- Building Energy Simulation Tool (BEST). AEG's BEST is a derivative of the DOE 2.2 building simulation model, used to estimate base-year UECs and EUIs, as well as measure savings for the HVAC-related measures.

- AEG's Database of Energy Conservation Measures (DEEM). AEG maintains an extensive database of measure data for our studies. Our database draws upon reliable sources including the California Database for Energy Efficient Resources (DEER), the EIA Technology Forecast Updates – Residential and Commercial Building Technologies – Reference Case, RS Means cost data, and Grainger Catalog Cost data.
- Recent studies. AEG has conducted more than 60 studies of EE potential in the last five years. We checked our input assumptions and analysis results against the results from these other studies, both within the region and across the country.

Other Secondary Data and Reports

Finally, a variety of secondary data sources and reports were used for this study. The main sources are identified below.

- Annual Energy Outlook. The Annual Energy Outlook (AEO), conducted each year by the U.S. Energy Information Administration (EIA), presents yearly projections and analysis of energy topics. For this study, we used data from the 2015 and 2017 AEO.
- American Community Survey. The US Census American Community Survey is an ongoing survey that provides data every year on household characteristics. <http://www.census.gov/acs/www/>
- Local Weather Data. Weather from NOAA's National Climatic Data Center for Spokane in Washington and Coure d'Alene in Idaho were used where applicable.
- EPRI End-Use Models (REEPS and COMMEND). These models provide the energy-use elasticities we apply to prices, household income, home size, heating, and cooling.
- Database for Energy Efficient Resources (DEER). The California Energy Commission and California Public Utilities Commission (CPUC) sponsor this database, which is designed to provide well-documented estimates of energy and peak demand savings values, measure costs, and effective useful life (EUL) for the state of California. We used the DEER database to cross check the measure savings we developed using BEST and DEEM.
- Other relevant resources: These include reports from the Consortium for Energy Efficiency, the EPA, and the American Council for an Energy-Efficient Economy. This also includes technical reference manuals (TRMs) from other states. When using data from outside the region, especially weather-sensitive data, AEG adapted assumptions for use within Avista's territory.

Application of Data to the Analysis

We now discuss how the data sources described above were used for each step of the study.

Data Application for Market Characterization

To construct the high-level market characterization of natural gas consumption and market size units (households for residential, floor space for commercial, and employees for industrial), we primarily used Avista's billing data as well as secondary data from AEG's Energy Market Profiles database.

Data Application for Market Profiles

The specific data elements for the market profiles, together with the key data sources, are shown in Table 2-5. To develop the market profiles for each segment, we used the following approach:

1. Develop control totals for each segment. These include market size, segment-level annual natural gas use, and annual intensity. Control totals were based on Avista's actual sales and customer-level information found in Avista's customer billing database. We used the market profiles from the 2016 CPA as a starting point.
2. Develop existing appliance saturations and the energy characteristics of appliances, equipment, and buildings using equipment flags within Avista's billing data, NEEA's 2016 RBSA, 2019 CBSA, and 2014 IFSA, DOE's 2015 RECS, the 2019 edition of the Annual Energy Outlook, AEG's Energy Market Profile (EMP) for the Pacific region, and the American Community Survey.
3. Ensure calibration to Avista control totals for annual natural gas sales in each sector and segment.
4. Compare and cross-check with other recent AEG studies.
5. Work with Avista staff to verify the data aligns with their knowledge and experience.

Table 2-5 Data Applied for the Market Profiles

Model Inputs	Description	Key Sources
Market size	Base-year residential dwellings, commercial floor space, and industrial employment	Avista 2019 actual sales Avista customer account database
Annual intensity	Residential: Annual use per household Commercial: Annual use per square foot Industrial: Annual use per employee	Avista customer account database AEG's Energy Market Profiles AEO 2019 – Pacific Region Other recent studies
Appliance/equipment saturations	Fraction of dwellings with an appliance/technology Percentage of C&I floor space/employment with equipment/technology	Avista 2013 GenPOP Survey 2016 RBSA, 2019 CBSA and IFSA 2018 American Community Survey AEG's Energy Market Profiles
UEC/EUI for each end-use technology	UEC: Annual natural gas use in homes and buildings that have the technology EUI: Annual natural gas use per square foot/employee for a technology in floor space that has the technology	HVAC uses: BEST simulations using prototypes developed for Avista Engineering analysis AEG DEEM AEO 2019 – Pacific Region Recent AEG studies
Appliance/equipment age distribution	Age distribution for each technology	2016 RBSA, 2019 CBSA, and recent AEG studies
Efficiency options for each technology	List of available efficiency options and annual energy use for each technology	Avista current program offerings AEG DEEM AEO 2019 CA DEER Recent AEG studies

Data Application for Baseline Projection

Table 2-6 summarizes the LoadMAP model inputs required for the baseline projection. These inputs are required for each segment within each sector, as well as for new construction and existing dwellings/buildings.

Table 2-6 Data Applied for the Baseline Projection in LoadMAP

Model Inputs	Description	Key Sources
Customer growth forecasts	Forecasts of new construction in residential and C&I sectors	Avista load forecast
Equipment purchase shares for baseline projection	For each equipment/technology, purchase shares for each efficiency level; specified separately for existing equipment replacement and new construction	Shipment data from AEO and ENERGY STAR AEO 2019 regional forecast assumptions ⁷ Appliance/efficiency standards analysis
Utilization model parameters	Price elasticities, elasticities for other variables (income, weather)	EPRI's REEPS and COMMEND models

In addition, assumptions were incorporated for known future equipment standards as of June 2020, as shown in Table 2-7 and Table 2-8. The assumptions tables here extend through 2025, after which all standards are assumed to hold steady.

⁷ We developed baseline purchase decisions using the Energy Information Agency's *Annual Energy Outlook* report (2017), which utilizes the National Energy Modeling System (NEMS) to produce a self-consistent supply and demand economic model. We calibrated equipment purchase options to match distributions/allocations of efficiency levels to manufacturer shipment data for recent years.

Table 2-7 Residential Natural Gas Equipment Federal Standards⁸

End Use	Technology	2019	2020	2021	2022	2023	2024	2025	
Space Heating	Furnace – Direct Fuel	AFUE 80%					AFUE 92%*		
	Boiler – Direct Fuel	AFUE 82%		AFUE 84%					
Secondary Heating	Fireplace	N/A							
Water Heating	Water Heater <= 55 gal.	UEF 0.58							
	Water Heater > 55 gal.	UEF 0.76							
Appliances	Clothes Dryer	CEF 3.30							
	Stove/Oven	N/A							
Miscellaneous	Pool Heater	TE 0.82							
	Miscellaneous	N/A							

* This code was originally set to take effect in 2021 but exempts smaller systems. The comment period was also extended into 2017 and the standard will not take effect until at least 5 years after that has concluded. As a result, we modeled this standard coming online officially in 2024.

Table 2-8 Commercial and Industrial Natural Gas Equipment Standards

End Use	Technology	2019	2020	2021	2022	2023	2024	2025
Cooling	Furnace	AFUE 80% / TE 0.80						
	Boiler	Average around AFUE 80% / TE 0.80 (varies by size)						
	Unit Heater	Standard (intermittent ignition and power venting or automatic flue damper)						
Water Heater	Water Heating	TE 0.80						

⁸ The assumptions tables here extend through 2025, after which all standards are assumed to hold steady.

Energy Conservation Measure Data Application

Table 2-9 details the energy-efficiency data inputs to the LoadMAP model. It describes each input and identifies the key sources used in the Avista analysis.

Table 2-9 Data Inputs for the Measure Characteristics in LoadMAP

Model Inputs	Description	Key Sources
Energy Impacts	The annual reduction in consumption attributable to each specific measure. Savings were developed as a percentage of the energy end use that the measure affects.	Avista TRM NWPC workbooks, RTF AEG BEST AEG DEEM AEO 2019 CA DEER Other secondary sources
Costs	Equipment Measures: Includes the full cost of purchasing and installing the equipment on a per-household, per-square-foot, or per employee basis for the residential, commercial, and industrial sectors, respectively. Non-Equipment Measures: Existing buildings – full installed cost. New Construction - the costs may be either the full cost of the measure, or as appropriate, it may be the incremental cost of upgrading from a standard level to a higher efficiency level.	Avista TRM NWPC workbooks, RTF AEG DEEM AEO 2019 CA DEER RS Means Other secondary sources
Measure Lifetimes	Estimates derived from the technical data and secondary data sources that support the measure demand and energy savings analysis.	Avista TRM NWPC workbooks, RTF AEG DEEM AEO 2019 CA DEER Other secondary sources
Applicability	Estimate of the percentage of dwellings in the residential sector, square feet in the commercial sector, or employees in the industrial sector where the measure is applicable and where it is technically feasible to implement.	2016 RBSA, 2019 CBSA 2015 WSEC for limitations on new construction AEG DEEM CA DEER Other secondary sources
On Market and Off Market Availability	Expressed as years for equipment measures to reflect when the equipment technology is available or no longer available in the market.	AEG appliance standards and building codes analysis

Data Application for Cost-effectiveness Screening

To perform the cost-effectiveness screening, a number of economic assumptions were needed. All cost and benefit values were analyzed as real dollars, converted from nominal provided by Avista. We applied Avista's long-term discount rate of 4.34% excluding inflation. LoadMAP is configured to vary this by market sector (e.g. residential and commercial) if Avista develops alternative values in the future.

Estimates of Customer Adoption

To estimate the timing and rate of customer adoption in the potential forecasts, two sets of parameters are needed:

- Technical diffusion curves for non-equipment measures. Equipment measures are installed when existing units fail. Non-equipment measures do not have this natural periodicity, so rather than installing all available non-equipment measures in the first year of the projection (instantaneous potential), they are phased in according to adoption schedules that generally align with the diffusion of similar equipment measures. For this analysis, we used the Council's retrofit ramp rates, labeled "Retro".
- Customer adoption rates, also referred to as take rates or ramp rates, are applied to measures on a year by year basis. These rates represent customer adoption of measures when delivered through a best-practice portfolio of well-operated efficiency programs under a reasonable policy or regulatory framework. Information channels are assumed to be established and efficient for marketing, educating consumers, and coordinating with trade allies and delivery partners. The primary barrier to adoption reflected in this case is customer preferences. Again, these are based on the ramp rates from the Northwest Power and Conservation Council's 2021 Plan.

The ramp rates referenced above were adapted for use for assessing natural gas measure potential. We describe this process in Section 7. The customer adoption rates used in this study are available in Appendix B.

3

MARKET CHARACTERIZATION AND MARKET PROFILES

In this section, we describe how customers in the Avista service territory use natural gas in the base year of the study, 2019. It begins with a high-level summary of energy use across all sectors and then delves into each sector in more detail.

Overall Energy Use Summary

Total natural gas consumption for all sectors for Avista's Washington territory in 2019 was 19,411,285 dekatherms. As shown in Figure 3-1 and Table 3-1, the residential sector accounts for the largest share of annual energy use at 64%, followed by the commercial sector at 35%. The industrial sector accounts for 2% of usage.

Figure 3-1 Sector-Level Natural Gas Use in Base Year 2019, Washington (annual therms, percent)

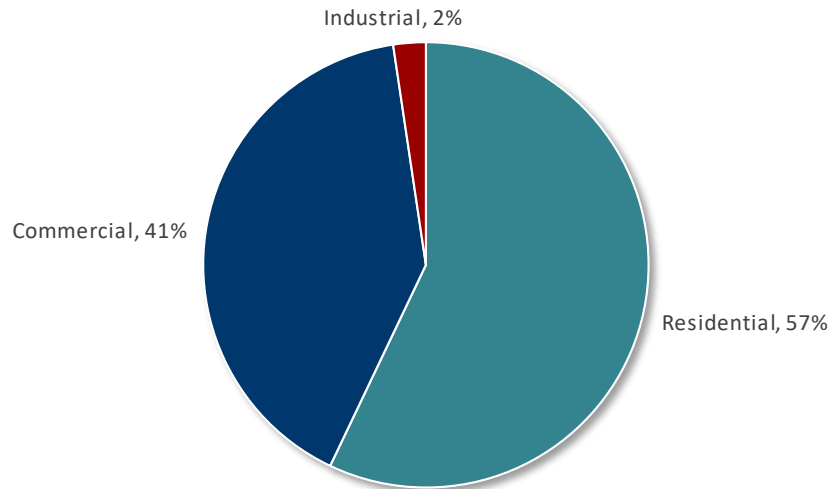

Table 3-1 Avista Sector Control Totals, Washington, 2019

Sector	Natural Gas Use (dekatherms)	% of Use
Residential	12,344,250	64%
Commercial	6,718,365	35%
Industrial	348,670	2%
Total	19,411,285	100%

Total natural gas consumption for all sectors for Avista's Idaho territory in 2019 was 10,131,866 dekatherms. As shown in Figure 3-2 and Table 3-2, the residential sector accounts for the largest share of annual energy use at 57%, followed by the commercial sector at 41%. The industrial sector accounts for 2% of usage.

Figure 3-2 Sector-Level Natural Gas Use in Base Year 2019, Idaho (annual therms, percent)

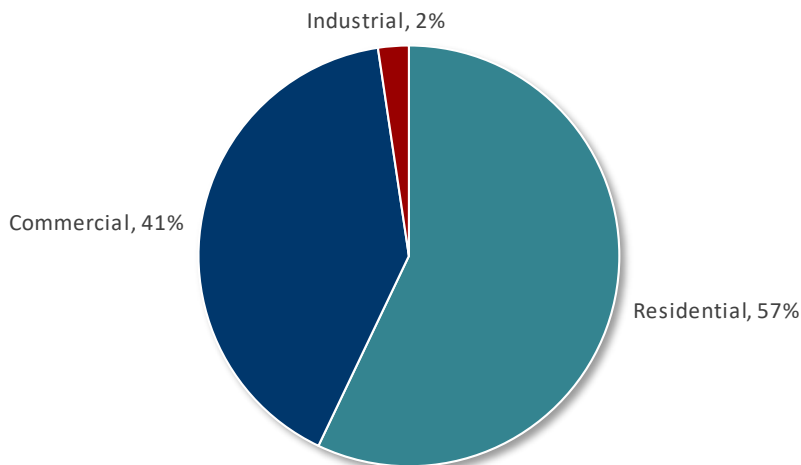

Table 3-2 Avista Sector Control Totals, Idaho, 2019

Sector	Natural Gas Use (dekatherms)	% of Use
Residential	5,782,934	57%
Commercial	4,110,228	41%
Industrial	238,705	2%
Total	10,131,866	100%

Residential Sector

Washington Characterization

The total number of households and gas sales for the service territory were obtained from Avista's actual sales for 2019. Details, including number of households and 2019 natural gas consumption for the residential sector in Washington can be found in Table 3-3 below. In 2019, there were nearly 156,000 households in Avista's Washington territory that used a total of 12,344,250 dekatherms, resulting in an average use per household of 796 therms per year. This is an important number for the calibration process.

These values represent weather actuals for 2019 and were adjusted within LoadMAP to normal weather using heating degree day, base 65°F, using data provided by Avista.

Table 3-3 Residential Sector Control Totals, Washington, 2019

Segment	Households	Natural Gas Use (dekatherms)	Annual Use/Customer (therms/HH)
Single Family	94,282	8,083,082	857
Multi-Family	8,684	469,031	540
Mobile Home	5,582	402,027	720
Low Income	46,521	3,390,109	729
Total	155,069	12,344,250	796

Figure 3-3 Residential Natural Gas Use by Segment, Washington, 2019

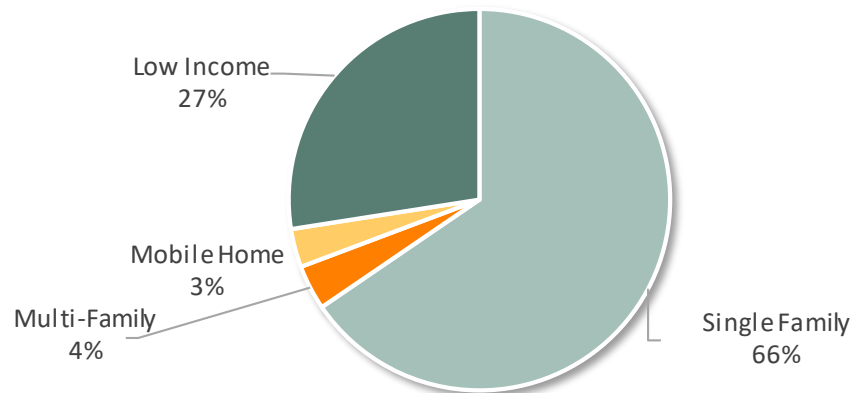
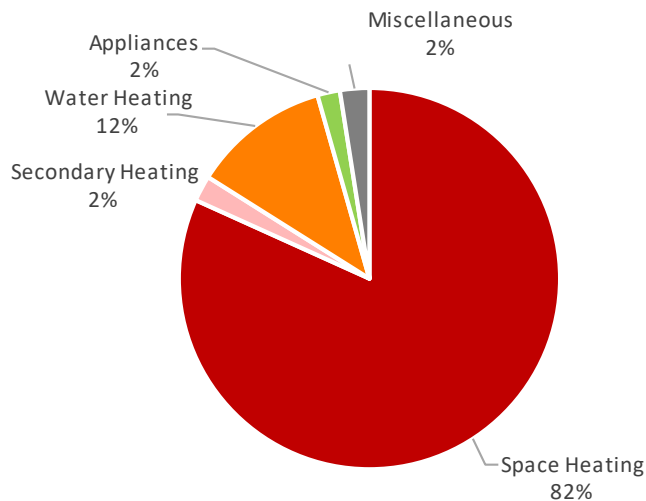

Figure 3-4 shows the distribution of annual natural gas consumption by end use for an average residential household. Space heating comprises most of the load at 82% followed by water heating at 12%. Appliances, Secondary Heating, and Miscellaneous loads make up the remaining portion (6%) of the total load. This is expected for a natural gas profile as there are very few miscellaneous technologies. One example is natural gas barbecues.

Figure 3-4 Residential Natural Gas Use by End Use, Washington, 2019



Avista’s GenPOP survey informed estimates of the saturation of key equipment types, which were used to distribute usage at the technology and end use level. However, because the vintage of the GenPOP survey is 2013, trends from more recent surveys were applied where appropriate, while still maintaining the more unique characteristics of Avista’s market.

Figure 3-4 presents average natural gas intensities by end use and housing type. Single family homes consume substantially more energy in space heating. This is due to two factors. The first is that single family homes are larger. The second is that more walls are exposed to the outside environment, compared to multifamily dwellings with many shared walls. This increases heat transfer, resulting in greater heating loads. Water heating consumption is higher in single family homes as well. This is due to a greater number of occupants, which increases the demand for hot water.

Figure 3-5 Residential Energy Intensity by End Use and Segment, Washington, 2019 (Annual Therms/HH)

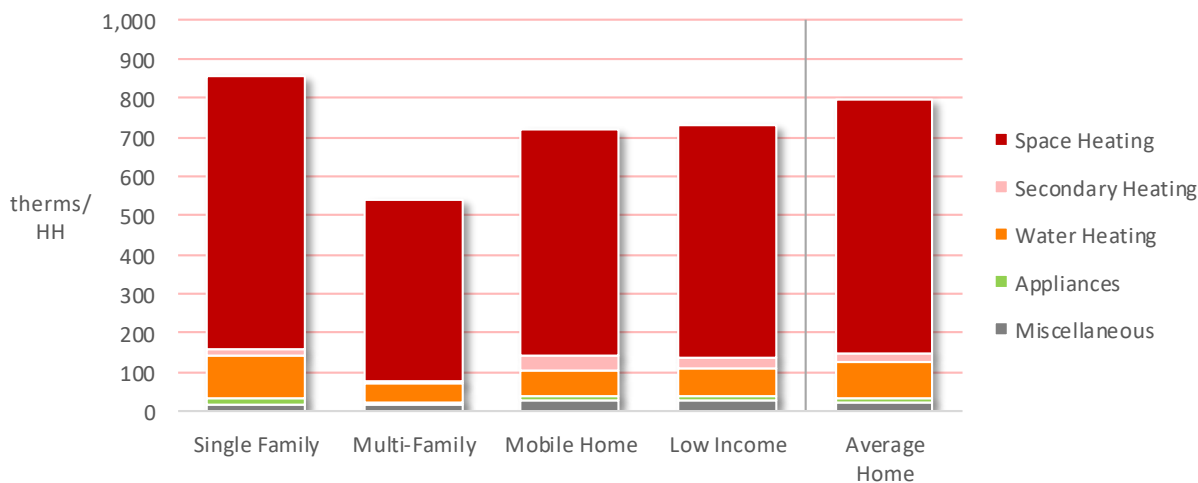

The market profile for an average home in the residential sector is presented in Table 3-4 below. An important step in the profile development process is model calibration. All consumption within an average home must sum up to the intensity extracted from billing data. This is necessary so estimates of consumption for a piece of equipment do not exceed the actual usage in a home.

Table 3-4 Average Market Profile for the Residential Sector, Washington, 2019

End Use	Technology	Saturation	UEC (therms)	Intensity (therms/HH)	Usage (dekatherms)
Space Heating	Furnace - Direct Fuel	84.9%	747.2	634.6	9,840,233
	Boiler - Direct Fuel	2.4%	674.2	16.2	251,417
Secondary Heating	Fireplace	12.7%	137.3	17.4	269,840
Water Heating	Water Heater <= 55 gal.	52.2%	177.8	92.9	1,440,263
Appliances	Clothes Dryer	27.3%	18.0	4.9	76,440
	Stove/Oven	58.9%	17.4	10.3	159,040
Miscellaneous	Pool Heater	0.8%	80.1	0.6	9,491
	Miscellaneous	100.0%	19.2	19.2	297,525
Total				796.0	12,344,250

Idaho Characterization

Details for the residential sector in Idaho can be found in Table 3-5 below. In 2019, there were 77,804 households in Avista's Washington territory that used a total of 5,782,934 dekatherms, resulting in an average use per household of 743 therms per year.

Table 3-5 Residential Sector Control Totals, Idaho, 2019

Segment	Households	Natural Gas Use (dekatherms)	Annual Use/Customer (therms/HH)
Single Family	47,305	3,780,793	799
Multi-Family	3,812	191,962	504
Mobile Home	3,501	235,056	671
Low Income	23,186	1,575,123	679
Total	77,804	5,782,934	743

Figure 3-6 Residential Natural Gas Use by Segment, Idaho, 2019

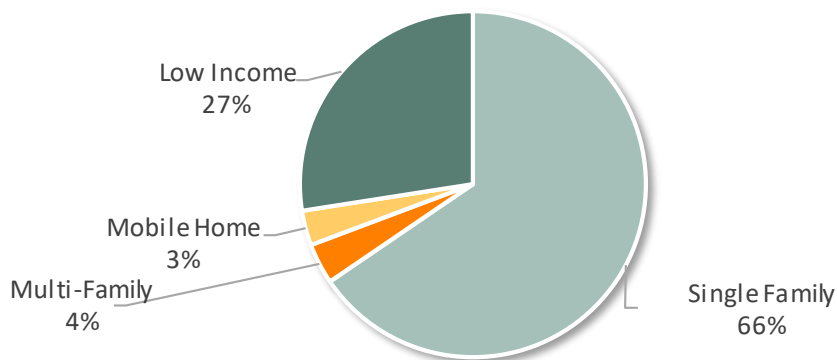
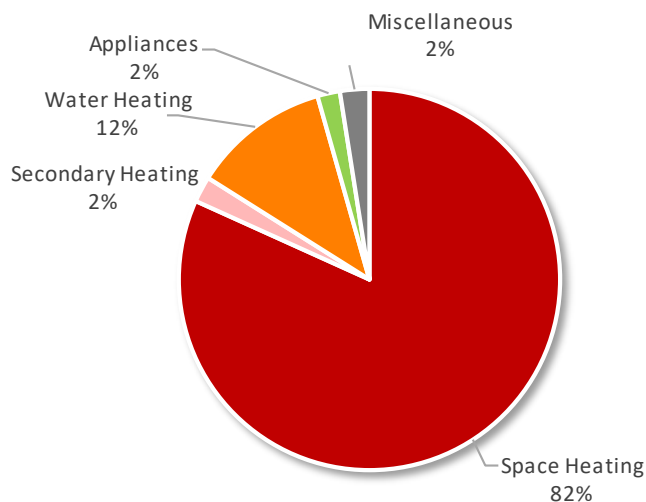

Figure 3-7 shows the distribution of annual natural gas consumption by end use for an average residential household. Space heating comprises a majority of the load at 82% followed by water heating at 12%. Miscellaneous loads make up a very small portion of the total load, as expected.

Figure 3-7 Residential Natural Gas Use by End Use, Idaho, 2019



Avista’s 2013 GenPOP survey informed estimates of the saturation of key equipment types, which were used to distribute usage at the technology and end use level.

Figure 3-8 presents average natural gas intensities by end use and housing type. Single family homes consume substantially more energy in space heating. Water heating consumption is higher in single family homes as well, due to a greater number of occupants, which increases the demand for hot water.

Figure 3-8 Residential Energy Intensity by End Use and Segment, Idaho, 2019 (Annual Therms/HH)

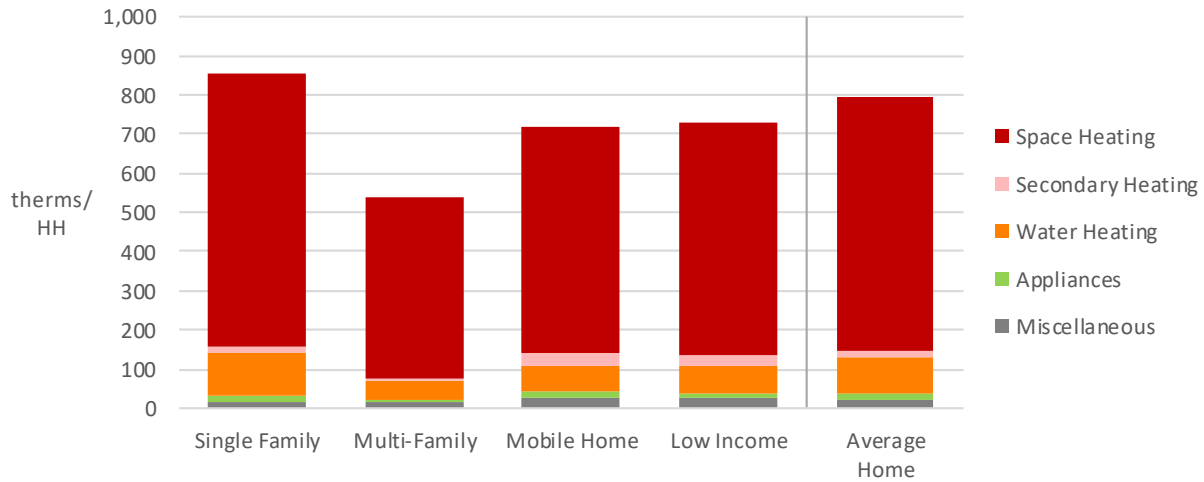

The market profile for an average home in the residential sector is presented in Table 3-6 below. An important step in the profile development process is model calibration. All consumption within an average home must sum up to the intensity extracted from billing data. This is necessary so estimates of consumption for a piece of equipment do not exceed the actual usage in a home.

Table 3-6 Average Market Profile for the Residential Sector, 2019

End Use	Technology	Saturation	UEC (therms)	Intensity (therms/HH)	Usage (dekatherms)
Space Heating	Furnace - Direct Fuel	81.0%	712.8	577.0	4,489,534
	Boiler - Direct Fuel	2.2%	643.6	14.0	108,672
Secondary Heating	Fireplace	16.9%	131.4	22.2	172,526
Water Heating	Water Heater <= 55 gal.	54.6%	177.5	96.9	753,951
Appliances	Clothes Dryer	14.7%	21.6	3.2	24,700
	Stove/Oven	31.7%	20.8	6.6	51,415
Miscellaneous	Pool Heater	0.3%	105.0	0.3	2,345
	Miscellaneous	100.0%	23.1	23.1	179,792
Total				743.3	5,782,934

Commercial Sector

Washington Characterization

The total number of nonresidential accounts and natural gas sales for the Washington service territory were obtained from Avista's customer account database.

AEG first separated the Commercial accounts from Industrial by analyzing the SIC codes and rate codes assigned in the company's billing system. Prior to using the data, AEG inspected individual accounts to confirm proper assignment. This was done on the top accounts within each segment, but also via spot checks when reviewing the database. Energy use from accounts where the customer type could not be identified were distributed proportionally to all C&I segments.

Once the billing data was analyzed, the final segment control totals were derived by distributing the total 2019 nonresidential load to the sectors and segments according to the proportions in the billing data.

Table 3-7 below shows the final allocation of energy to each segment in the commercial sector, as well as the energy intensity on a square-foot basis. Intensities for each segment were derived from a combination of the 2019 CBSA and equipment saturations extracted from Avista's database. The CBSA intensities corresponded to spaces with lower natural gas saturations than Avista's database, so AEG increased intensities proportionally based on the additional presence of natural gas-consuming equipment.

Table 3-7 Commercial Sector Control Totals, Washington, 2019

Segment	Description	Intensity (therms/Sq Ft)	2019 Natural Gas Use (dekatherms)
Office	Traditional office-based businesses including finance, insurance, law, government buildings, etc.	0.60	481,953
Restaurant	Sit-down, fast food, coffee shop, food service, etc.	2.68	65,351
Retail	Department stores, services, boutiques, strip malls etc.	0.83	837,065
Grocery	Supermarkets, convenience stores, market, etc.	0.95	154,034
School	Day care, pre-school, elementary, secondary schools	0.29	269,873
College	College, university, trade schools, etc.	0.62	272,030
Health	Health practitioner office, hospital, urgent care centers, etc.	1.04	315,668
Lodging	Hotel, motel, bed and breakfast, etc.	0.68	172,829
Warehouse	Large storage facility, refrigerated/unrefrigerated warehouse	0.68	358,315
Miscellaneous	Catchall for buildings not included in other segments, includes churches, recreational facilities, public assembly, correctional facilities, etc.	1.16	1,183,111
Total		0.75	4,110,228

Figure 3-9 shows each segments' natural gas consumption as a percentage of the entire commercial sector energy consumption. The three segments with the highest natural gas usage in 2019 are miscellaneous, retail, and office, in descending order. As expected, the highest intensity segment is restaurant. This is based on the high presence of food preparation equipment.

Figure 3-9 Commercial Natural Gas Use by Segment, Washington, 2019

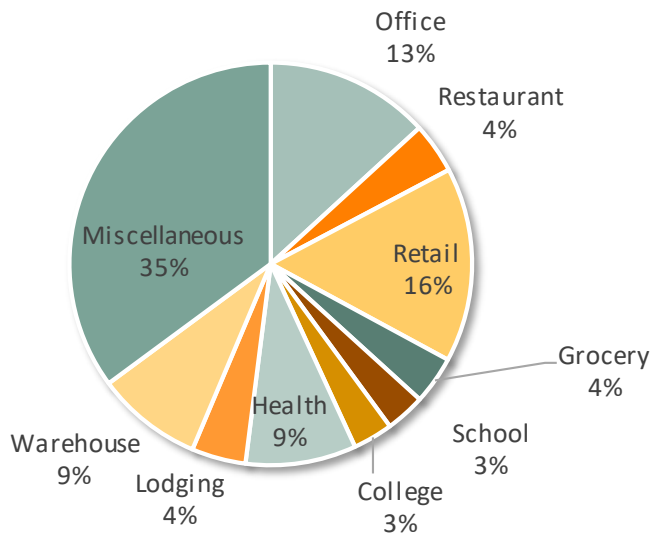

Figure 3-10 shows the distribution of natural gas consumption by end use for the entire commercial sector. Space heating is the largest end use, followed closely by water heating. The miscellaneous end use is quite small, as expected.

Figure 3-10 Commercial Sector Natural Gas Use by End Use, Washington, 2019

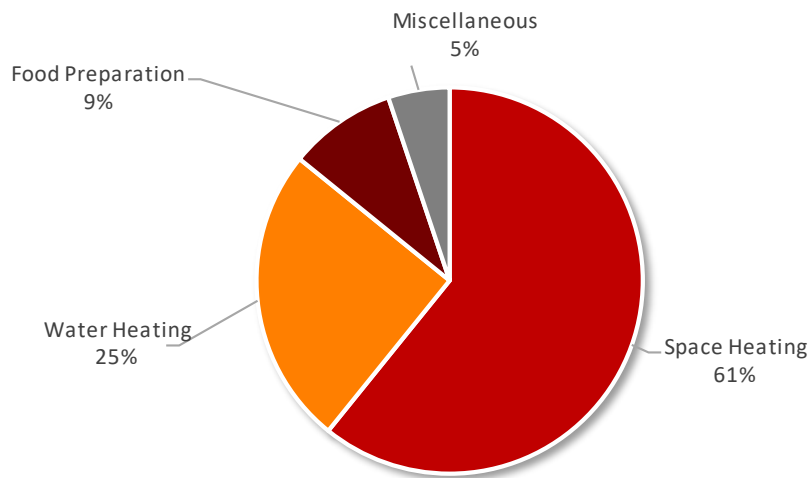
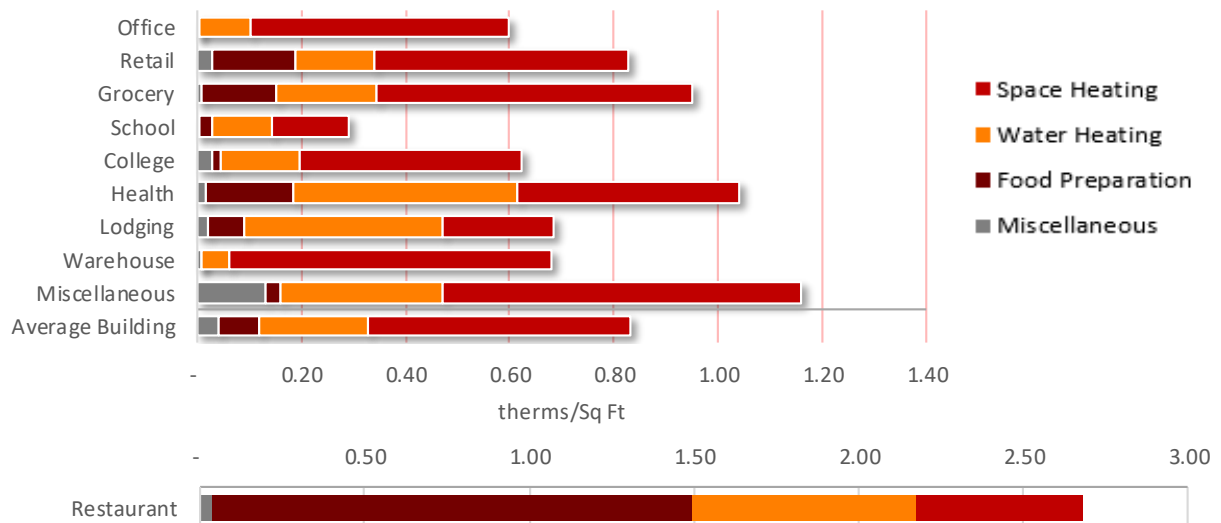

Figure 3-11 presents average natural gas intensities by end use and segment.

Figure 3-11 Commercial Energy Usage Intensity by End Use and Segment, Washington, 2019 (Annual Therms/Sq. Ft)



The total market profile for an average building in the commercial sector is presented in Table 3-8 below. Avista customer account data informed the market profile by providing information on saturation of key equipment types. Secondary data was used to develop estimates of energy intensity and square footage and to fill in saturations for any equipment types not included in the database.

Table 3-8 Average Market Profile for the Commercial Sector, Washington, 2019

End Use	Technology	Saturation	EUI (therms/Sq Ft)	Intensity (therms/Sq Ft)	Usage (dekatherms)
Space Heating	Furnace	53.6%	0.44	0.23	1,898,166
	Boiler	32.6%	0.79	0.26	2,086,967
	Unit Heater	4.7%	0.27	0.01	100,644
Water Heating	Water Heater	69.7%	0.30	0.21	1,681,122
Food Preparation	Oven	11.3%	0.06	0.01	53,746
	Conveyor Oven	5.6%	0.10	0.01	45,982
	Double Rack Oven	5.6%	0.15	0.01	69,855
	Fryer	7.3%	0.34	0.03	202,977
	Broiler	12.2%	0.07	0.01	70,869
	Griddle	16.4%	0.05	0.01	70,017
	Range	17.9%	0.06	0.01	82,852
	Steamer	2.1%	0.06	0.00	9,251
	Commercial Food Prep Other	0.2%	0.01	0.00	149
Miscellaneous	Pool Heater	0.9%	0.01	0.00	1,034
	Miscellaneous	100.0%	0.04	0.04	344,734
Total				0.83	6,718,365

Idaho Characterization

The total number of nonresidential accounts and natural gas sales for the Idaho service territory were obtained from Avista's customer account database.

Table 3-9 below shows the final allocation of energy to each segment in the commercial sector, as well as the energy intensity on a square-foot basis. Intensities for each segment were derived from a combination of the 2019 CBSA and equipment saturations extracted from Avista's database. The CBSA intensities corresponded to spaces with lower natural gas saturations than Avista's database, so AEG increased intensities proportionally based on the additional presence of natural gas-consuming equipment.

Table 3-9 Commercial Sector Control Totals, Idaho, 2019

Segment	Description	Intensity (therms/Sq Ft)	2019 Natural Gas Use (dekatherms)
Office	Traditional office-based businesses including finance, insurance, law, government buildings, etc.	0.60	481,953
Restaurant	Sit-down, fast food, coffee shop, food service, etc.	2.68	65,351
Retail	Department stores, services, boutiques, strip malls etc.	0.83	837,065
Grocery	Supermarkets, convenience stores, market, etc.	0.95	154,034
School	Day care, pre-school, elementary, secondary schools	0.29	269,873
College	College, university, trade schools, etc.	0.62	272,030
Health	Health practitioner office, hospital, urgent care centers, etc.	1.04	315,668
Lodging	Hotel, motel, bed and breakfast, etc.	0.68	172,829
Warehouse	Large storage facility, refrigerated/unrefrigerated warehouse	0.68	358,315
Miscellaneous	Catchall for buildings not included in other segments, includes churches, recreational facilities, public assembly, correctional facilities, etc.	1.16	1,183,111
Total		0.75	4,110,228

Figure 3-12 shows each segments' natural gas consumption as a percentage of the entire commercial sector energy consumption. The four segments with the highest natural gas usage in 2019 are miscellaneous, retail, office, and warehouse, in descending order. As expected, the highest intensity segment is restaurant. This is based on the high presence of food preparation equipment.

Figure 3-12 Commercial Natural Gas Use by Segment, Idaho, 2019

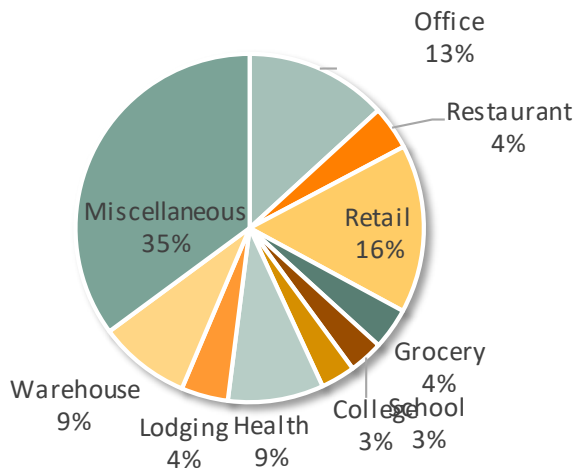

Figure 3-13 shows the distribution of natural gas consumption by end use for the entire commercial sector. Space heating is the largest end use, followed closely by water heating and food preparation. The miscellaneous end use is quite small, as expected.

Figure 3-13 Commercial Sector Natural Gas Use by End Use, Idaho, 2019

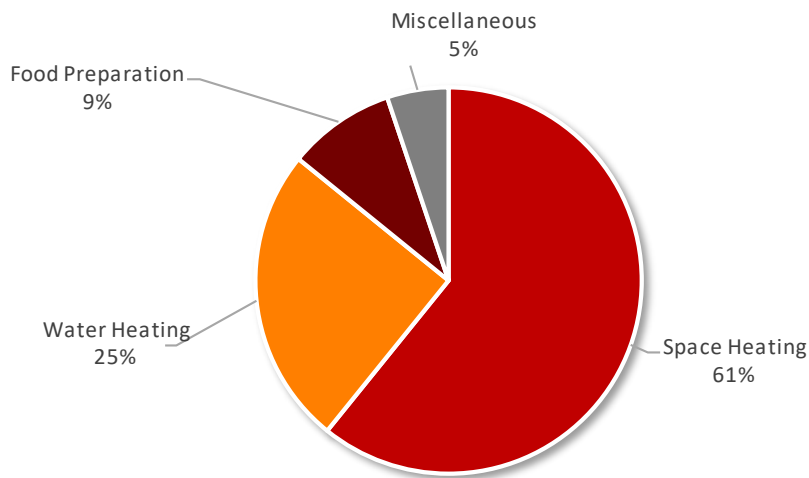
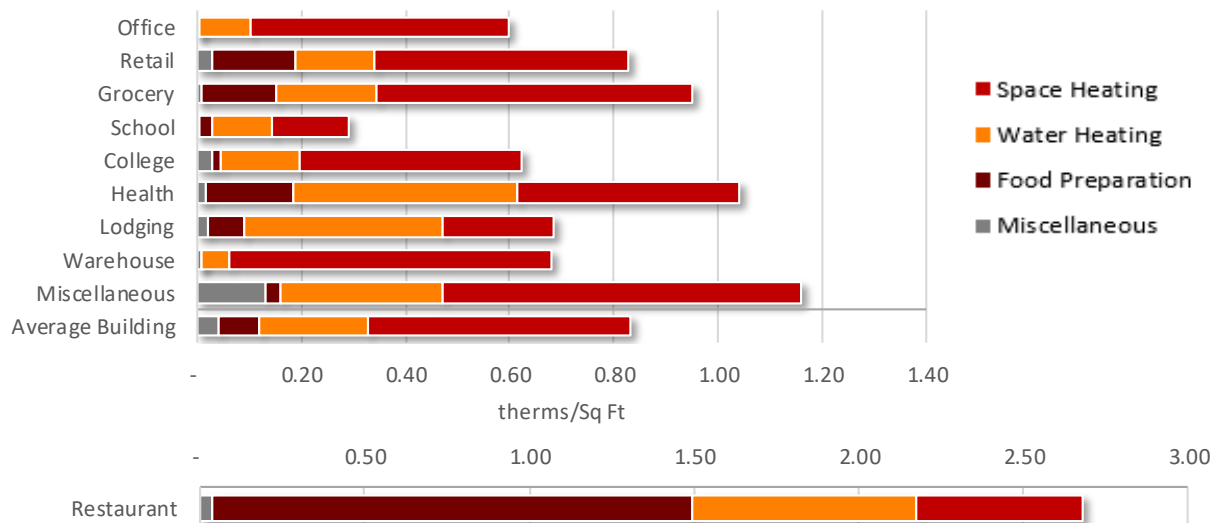

Figure 3-14 presents average natural gas intensities by end use and segment.

Figure 3-14 Commercial Energy Usage Intensity by End Use and Segment, Idaho, 2019 (Annual Therms/Sq. Ft)



The total market profile for an average building in the commercial sector is presented in Table 3-10 below. Avista customer account data informed the market profile by providing information on saturation of key equipment types. Secondary data was used to develop estimates of energy intensity and square footage and to fill in saturations for any equipment types not included in the database.

Table 3-10 Average Market Profile for the Commercial Sector, Idaho, 2019

End Use	Technology	Saturation	EUI (therms/ Sq Ft)	Intensity (therms/ Sq Ft)	Usage (dekatherms)
Space Heating	Furnace	50.7%	0.43	0.22	1,183,907
	Boiler	35.7%	0.66	0.24	1,286,757
	Unit Heater	4.9%	0.25	0.01	67,294
Water Heating	Water Heater	69.3%	0.27	0.19	1,025,922
Food Preparation	Oven	9.9%	0.07	0.01	37,863
	Conveyor Oven	4.9%	0.12	0.01	32,393
	Double Rack Oven	4.9%	0.18	0.01	49,212
	Fryer	7.2%	0.32	0.02	125,738
	Broiler	11.3%	0.05	0.01	29,409
	Griddle	15.7%	0.04	0.01	32,103
	Range	17.5%	0.04	0.01	39,839
	Steamer	3.1%	0.04	0.00	5,935
	Commercial Food Prep Other	0.3%	0.01	0.00	141
Miscellaneous	Pool Heater	0.8%	0.01	0.00	563
	Miscellaneous	100.0%	0.04	0.04	193,152
Total				0.75	4,110,228

Industrial Sector

Washington Characterization

The total sum of natural gas used in 2019 by Avista's Washington industrial customers was 348,670 dekatherms. Like in the commercial sector, customer account data was used to allocate usage among segments. Energy intensity was derived from AEG's Energy Market Profiles database. Most industrial measures are installed through custom programs, where the unit of measure is not as necessary to estimate potential.

Table 3-11 Industrial Sector Control Totals, Washington, 2019

Segment	Intensity (therms/employee)	Natural Gas Usage (dekatherms)
Washington Industrial	1,716	348,670

Figure 3-15 shows the distribution of annual natural gas consumption by end use for all industrial customers. Two major sources were used to develop this consumption profile. The first was AEG's analysis of warehouse usage as part of the commercial sector. We begin with this prototype as a starting point to represent non-process loads. We then added in process loads using our Energy Market Profiles database, which summarizes usage by end use and process type. Accordingly, process is the largest overall end use for the industrial sector, accounting for 87% of energy use. Heating is the second largest end use, and miscellaneous, non-process industrial uses round out consumption.

Figure 3-15 Industrial Natural Gas Use by End Use, Washington, 2019

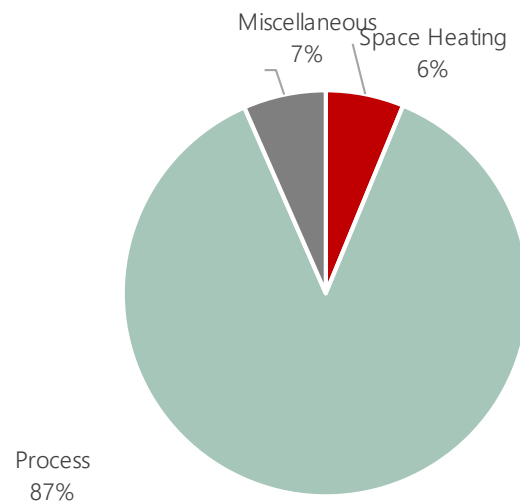

Table 3-12 shows the composite market profile for the industrial sector. Process cooling is very small and represents niche technologies such as gas-driven absorption chillers.

Table 3-12 Average Natural Gas Market Profile for the Industrial Sector, Washington, 2019

End Use	Technology	Saturation	EUI (therms/ sq ft)	Intensity (therms/ Sq ft)	Usage (dekatherms)
Space Heating	Furnace	27.5%	107.88	29.64	6,024
	Boiler	58.8%	107.88	63.42	12,890
	Unit Heater	13.7%	107.88	14.82	3,012
Process	Process Boiler	100.0%	758.47	758.47	154,154
	Process Heating	100.0%	675.00	675.00	137,190
	Process Cooling	100.0%	7.83	7.83	1,592
	Other Process	100.0%	50.93	50.93	10,350
Miscellaneous	Miscellaneous	100.0%	115.41	115.41	23,457
Total				1,715.53	348,670

Idaho Characterization

The total sum of natural gas used in 2019 by Avista's Idaho industrial customers was 238,705 dekatherms. Energy use intensity is slightly higher than Washington at 2,008 therms/sq ft.

Table 3-13 Industrial Sector Control Totals, Idaho, 2019

Segment	Intensity (therms/employee)	Natural Gas Usage (dekatherms)
Idaho Industrial	2,008	238,705

Figure 3-16 shows the distribution of annual natural gas consumption by end use for all industrial customers. Two major sources were used to develop this consumption profile. The first was AEG's analysis of warehouse usage as part of the commercial sector. We begin with this prototype as a starting point to represent non-process loads. We then added in process loads using our Energy Market Profiles database, which summarizes usage by end use and process type. Accordingly, process is the largest overall end use for the industrial sector, accounting for 87% of energy use. Heating is the second largest end use, and miscellaneous, non-process industrial uses round out consumption.

Figure 3-16 Industrial Natural Gas Use by End Use, Idaho, 2019

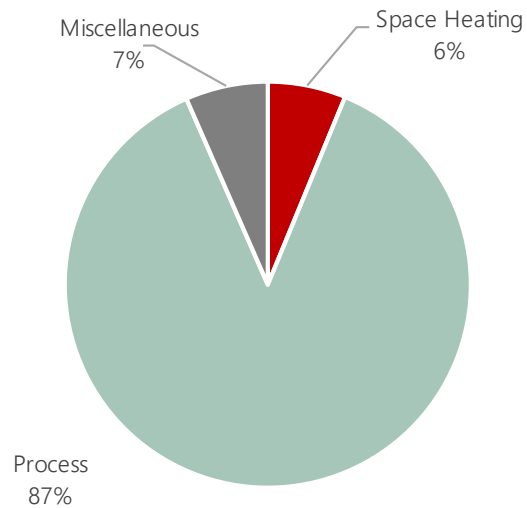

Table 3-14 shows the composite market profile for the industrial sector. Process cooling is very small and represents technologies such as gas-driven absorption chillers.

Table 3-14 Average Natural Gas Market Profile for the Industrial Sector, Idaho, 2019

End Use	Technology	Saturation	EUI (therms/ sq ft)	Intensity (therms/ Sq ft)	Usage (dekatherms)
Space Heating	Furnace	27.5%	126.29	34.70	4,124
	Boiler	58.8%	126.29	74.24	8,824
	Unit Heater	13.7%	126.29	17.35	2,062
Process	Process Boiler	100.0%	887.92	887.92	105,537
	Process Heating	100.0%	790.21	790.21	93,922
	Process Cooling	100.0%	9.17	9.17	1,090
	Other Process	100.0%	59.62	59.62	7,086
Miscellaneous	Miscellaneous	100.0%	135.11	135.11	16,059
Total				2,008.33	238,705

4

BASELINE PROJECTION

Prior to developing estimates of energy conservation potential, we developed a baseline end-use projection to quantify what the consumption is likely to be in the future in absence of any energy conservation programs. The savings from past programs are embedded in the forecast, but the baseline projection assumes that those past programs cease to exist in the future. Thus, the potential analysis captures all possible savings from future programs.

The baseline projection incorporates assumptions about:

- 2019 energy consumption based on the market profiles
- Customer population growth
- Appliance/equipment standards and building codes already mandated
- Appliance/equipment purchase decisions
- Avista's customer forecast

Trends in fuel shares and appliance saturations and assumptions about miscellaneous natural gas growth

Although it aligns closely, the baseline projection is not Avista's official load forecast. Rather it was developed as an integral component of our modeling construct to serve as the metric against which energy conservation potentials are measured. This chapter presents the baseline projections we developed for this study. Below, we present the baseline projections for each sector, which include projections of annual use in dekatherms. We also present a summary across all sectors.

Overall Baseline Projection

Washington Projection

Table 4-1 and Figure 4-1 provide a summary of the baseline projection for annual use by sector for the Avista’s Washington service territory. Overall, the forecast shows modest growth in natural gas consumption, driven by the residential and commercial sectors

Table 4-1 Baseline Projection Summary by Sector, Washington, Selected Years (dekatherms)

Sector	2019	2021	2023	2030	2040	% Change ('19-'40)	Avg. Growth
Residential	12,344,250	12,180,267	12,523,563	13,568,829	14,418,227	16.8%	0.7%
Commercial	6,718,365	6,596,157	6,622,904	6,725,824	6,909,984	2.9%	0.1%
Industrial	348,670	341,870	336,318	317,863	291,665	-16.3%	-0.9%
Total	19,411,285	19,118,293	19,482,785	20,612,516	21,619,876	11.4%	0.5%

Figure 4-1 Baseline Projection Summary by Sector, Washington (dekatherms)

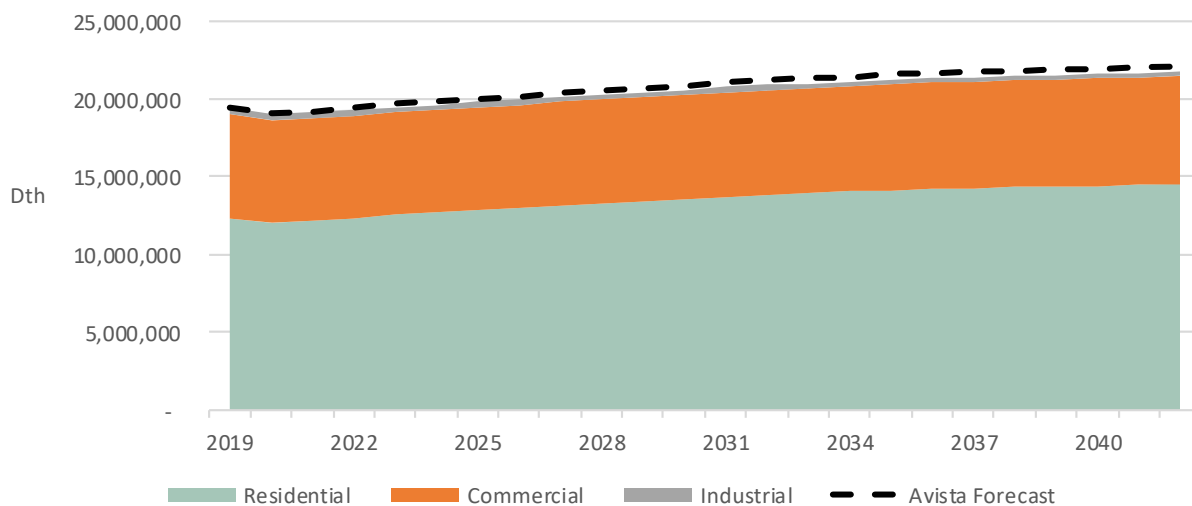

Idaho Projection

Table 4-2 and Figure 4-2 provide a summary of the baseline projection for annual use by sector for Avista’s Idaho service territory. Overall, the forecast shows modest growth in natural gas consumption, driven roughly equally by the residential sector.

Table 4-2 Baseline Projection Summary by Sector, Idaho, Selected Years (dekatherms)

Sector	2019	2021	2023	2030	2040	% Change ('19-'40)	Avg. Growth
Residential	5,782,934	5,757,753	5,989,779	6,677,657	7,614,162	31.7%	1.3%
Commercial	4,110,228	4,027,575	4,071,925	4,112,209	4,199,550	2.2%	0.1%
Industrial	238,705	234,049	229,897	214,701	193,107	-19.1%	-1.0%
Total	10,131,866	10,019,377	10,291,600	11,004,568	12,006,819	18.5%	0.8%

Figure 4-2 Baseline Projection Summary by Sector, Idaho (dekatherms)

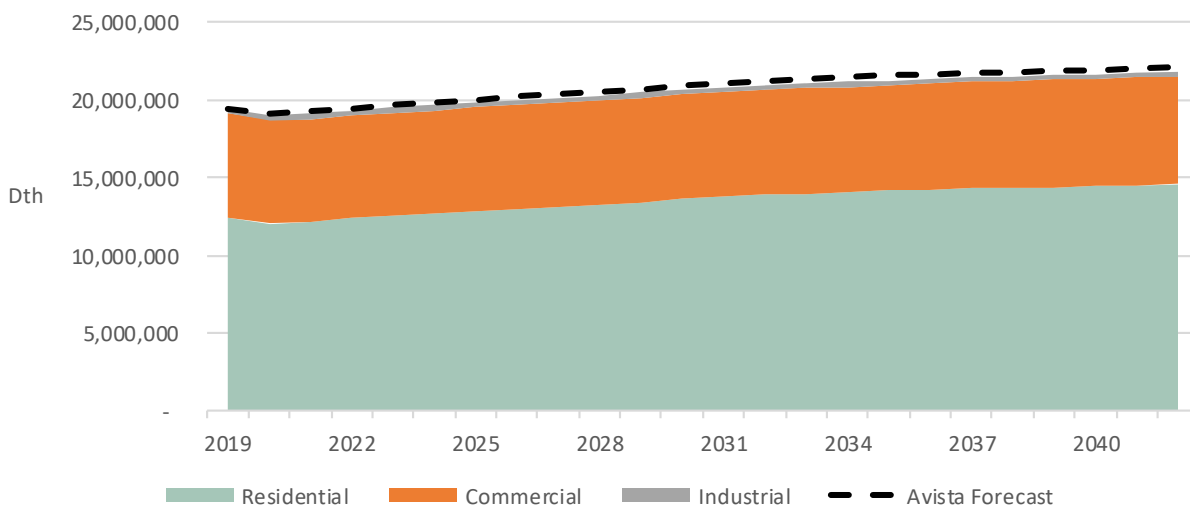

Residential Sector

Washington Projection

Table 4-3 and

Figure 4-3 present the baseline projection for natural gas at the end-use level for the residential sector, as a whole. Overall, residential use increases from 12,344,250 dekatherms in 2019 to 14,418,227 dekatherms in 2040, an increase of 16.8%. Factors affecting growth include a moderate increase in number of households and customers, and a decrease in equipment consumption due to future standards and naturally occurring efficiency improvements (notably the AFUE upcoming 92% furnace standard).

We model gas-fired fireplaces as secondary heating. These consume energy and may heat a space but are rarely relied on to be a primary heating technology. As such, they are estimated to be more aesthetic and less weather-dependent. This end use grows faster than others since new homes are more likely to install a unit, increasing fireplace stock. Miscellaneous is a very small end use including technologies with low penetration, such as gas barbeques.

Table 4-3 Residential Baseline Projection by End Use, Washington (dekatherms)

End Use	2019	2021	2023	2030	2040	% Change ('19-'40)	Avg. Growth
Space Heating	10,091,649	9,884,547	10,148,613	10,898,317	11,377,205	12.7%	0.6%
Secondary Heating	269,840	268,460	275,328	300,411	328,634	21.8%	0.9%
Water Heating	1,440,263	1,475,763	1,532,049	1,743,214	2,015,278	39.9%	1.6%
Appliances	235,480	240,292	248,325	278,255	315,399	33.9%	1.4%
Miscellaneous	307,017	311,205	319,248	348,632	381,710	24.3%	1.0%
Total	12,344,250	12,180,267	12,523,563	13,568,829	14,418,227	16.8%	0.7%

Figure 4-3 Residential Baseline Projection by End Use, Washington (dekatherms)

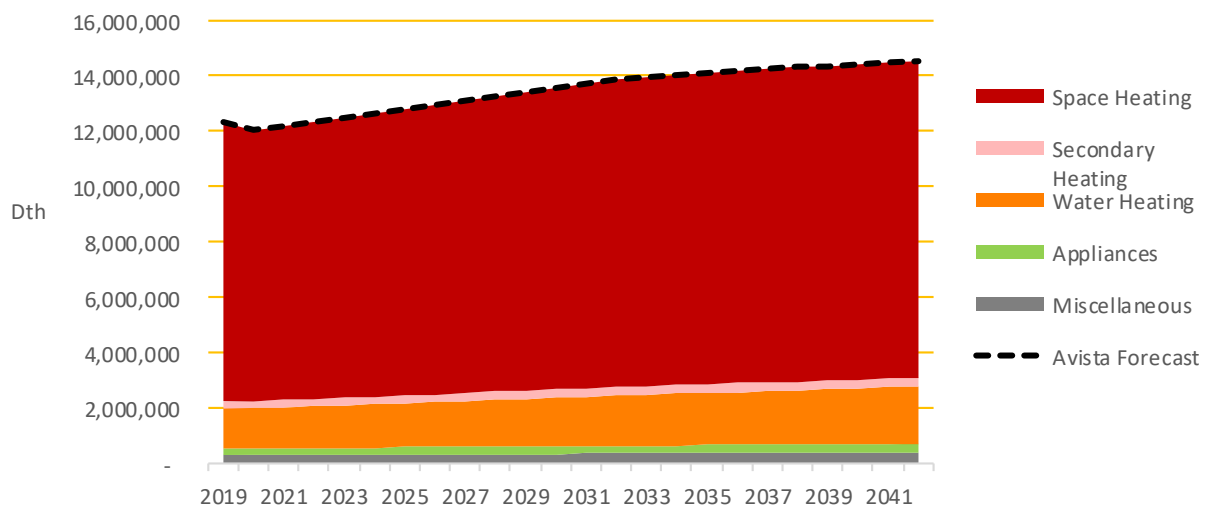

Idaho Projection

Table 4-4 and Figure 4-4 present the baseline projection for natural gas at the end-use level for the residential sector, as a whole. Overall, residential use increases from 5,782,934 dekatherms in 2019 to 7,614,162 dekatherms in 2040, an increase of 31.7%.

Table 4-4 Residential Baseline Projection by End Use, Idaho (dekatherms)

End Use	2019	2021	2023	2030	2040	% Change ('19-'40)	Avg. Growth
Space Heating	4,598,206	4,543,217	4,723,227	5,238,352	5,912,290	28.6%	1.2%
Secondary Heating	172,526	172,767	178,636	197,303	224,372	30.1%	1.3%
Water Heating	753,951	777,712	814,170	936,965	1,126,311	49.4%	1.9%
Appliances	76,115	78,239	81,587	92,714	109,623	44.0%	1.7%
Miscellaneous	182,137	185,819	192,158	212,322	241,565	32.6%	1.3%
Total	5,782,934	5,757,753	5,989,779	6,677,657	7,614,162	31.7%	1.3%

Figure 4-4 Residential Baseline Projection by End Use, Idaho (dekatherms)

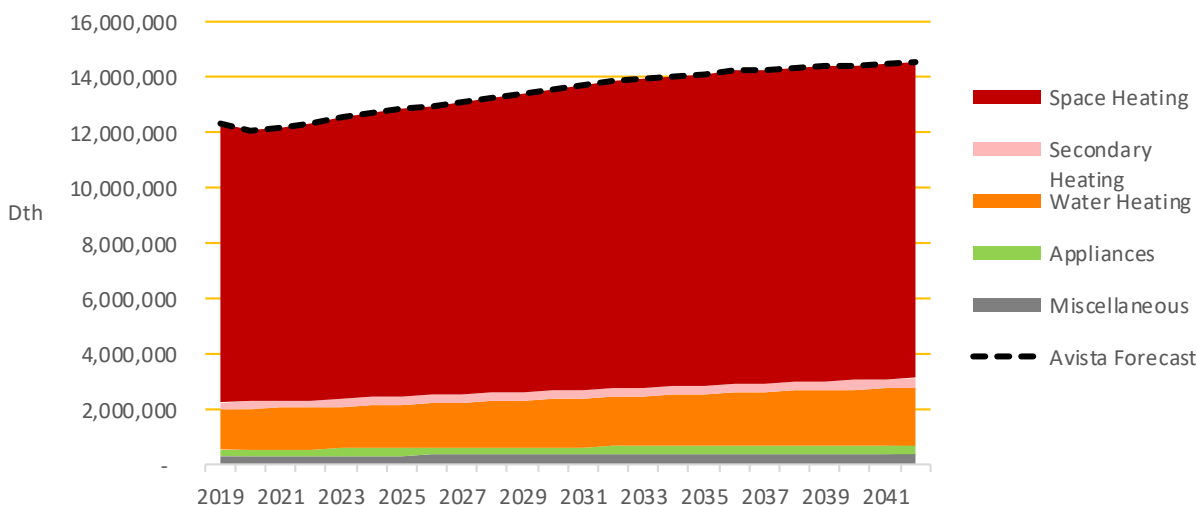

Commercial Sector

Washington Projection

Annual natural gas use in the commercial sector grows 24.7% during the overall forecast horizon, starting at 6,197,173 dekatherms in 2019, and increasing to 6,909,984 dekatherms in 2040. Table 4-5 and Figure 4-5 present the baseline projection at the end-use level for the commercial sector, as a whole. Similar to the residential sector, market size is increasing and usage per square foot is decreasing slightly.

Table 4-5 Commercial Baseline Projection by End Use, Washington (dekatherms)

End Use	2019	2021	2023	2030	2040	% Change ('19-'40)	Avg. Growth
Space Heating	4,085,777	3,956,080	3,975,113	4,039,997	4,138,972	1.3%	0.1%
Water Heating	1,681,122	1,679,620	1,678,355	1,686,750	1,736,171	3.3%	0.2%
Food Preparation	605,698	611,422	617,138	636,007	658,775	8.8%	0.4%
Miscellaneous	345,768	349,035	352,298	363,069	376,067	8.8%	0.4%
Total	6,718,365	6,596,157	6,622,904	6,725,824	6,909,984	2.9%	0.1%

Figure 4-5 Commercial Baseline Projection by End Use, Washington (dekatherms)

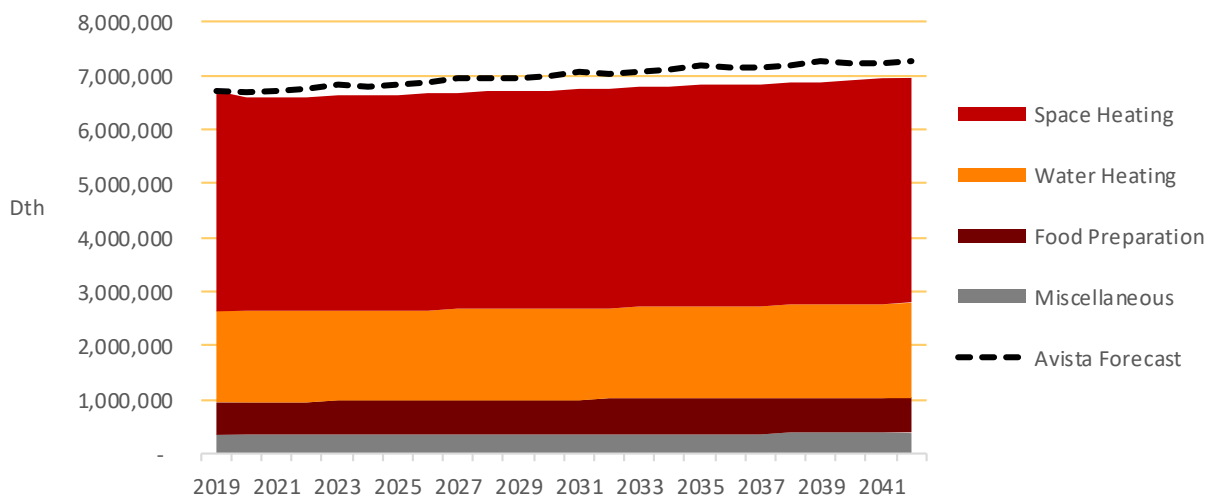

Idaho Projection

Annual natural gas use in the Idaho commercial sector grows 2.2% during the overall forecast horizon, starting at 4,110,228 dekatherms in 2019, and increasing to 4,199,550 dekatherms in 2040. Table 4-6 and Figure 4-6 present the baseline projection at the end-use level for the commercial sector, as a whole. Similar to the residential sector, market size is increasing and usage per square foot is decreasing slightly.

Table 4-6 Commercial Baseline Projection by End Use, Idaho (dekatherms)

End Use	2019	2021	2023	2030	2040	% Change ('19-'40)	Avg. Growth
Space Heating	2,537,957	2,453,619	2,482,525	2,509,340	2,555,560	0.7%	0.0%
Water Heating	1,025,922	1,023,306	1,029,755	1,029,131	1,052,936	2.6%	0.1%
Food Preparation	352,633	355,410	361,216	370,312	381,488	8.2%	0.4%
Miscellaneous	193,715	195,240	198,430	203,426	209,566	8.2%	0.4%
Total	4,110,228	4,027,575	4,071,925	4,112,209	4,199,550	2.2%	0.1%

Figure 4-6 Commercial Baseline Projection by End Use, Idaho (dekatherms)

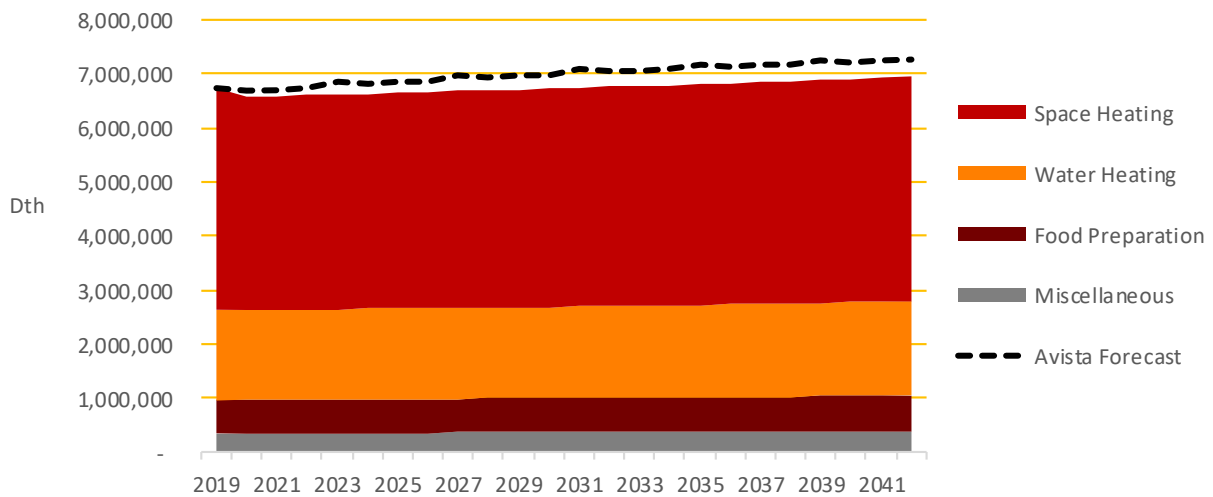

Industrial Sector

Washington Projection

Industrial sector usage increases throughout the planning horizon. Table 4-7 and Figure 4-7 present the projection at the end-use level. Overall, industrial annual natural gas use decreases from 348,670 dekatherms in 2019 to 291,665 dekatherms in 2040. Growth is consistently around -0.9% per year.

Table 4-7 Industrial Baseline Projection by End Use, Washington (dekatherms)

End Use	2019	2021	2023	2030	2040	% Change ('19-'40)	Avg. Growth
Space Heating	21,926	20,665	20,227	18,789	16,903	-22.9%	-1.2%
Process	303,287	298,146	293,399	277,603	255,037	-15.9%	-0.8%
Miscellaneous	23,457	23,059	22,692	21,470	19,725	-15.9%	-0.8%
Total	348,670	341,870	336,318	317,863	291,665	-16.3%	-0.9%

Figure 4-7 Industrial Baseline Projection by End Use, Washington (dekatherms)

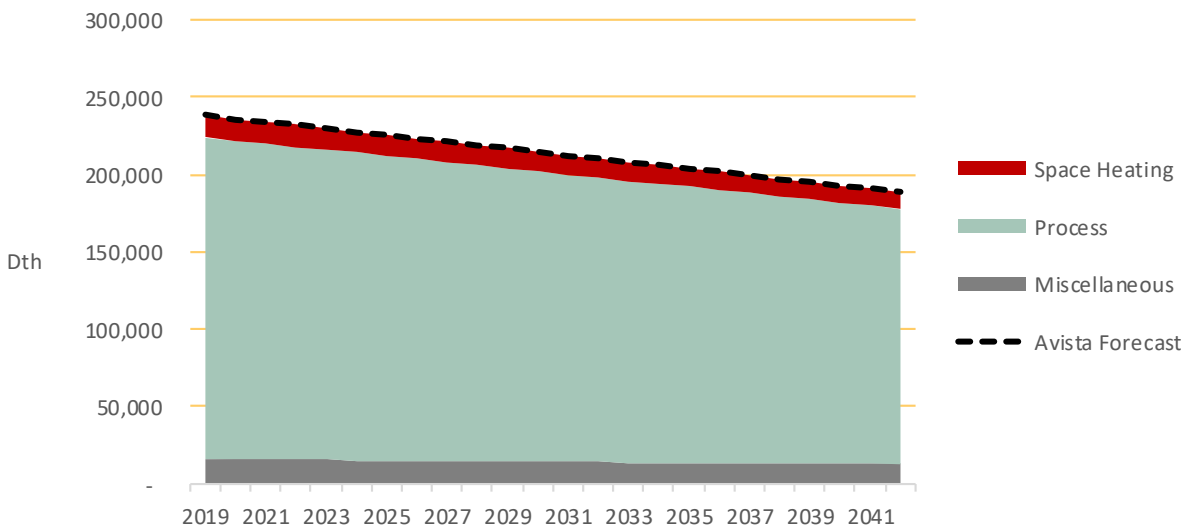

Idaho Projection

Industrial sector usage increases throughout the planning horizon. Table 4-8 and Figure 4-8 present the projection at the end-use level. Overall, industrial annual natural gas use decreases from 238,705 dekatherms in 2019 to 193,107 dekatherms in 2040.

Table 4-8 Industrial Baseline Projection by End Use, Idaho (dekatherms)

End Use	2019	2021	2023	2030	2040	% Change ('19-'40)	Avg. Growth
Heating	15,011	14,147	13,829	12,713	11,232	-25.2%	-1.4%
Process	207,635	204,115	200,556	187,488	168,818	-18.7%	-1.0%
Miscellaneous	16,059	15,787	15,511	14,501	13,057	-18.7%	-1.0%
Total	238,705	234,049	229,897	214,701	193,107	-19.1%	-1.0%

Figure 4-8 Industrial Baseline Projection by End Use, Idaho (dekatherms)

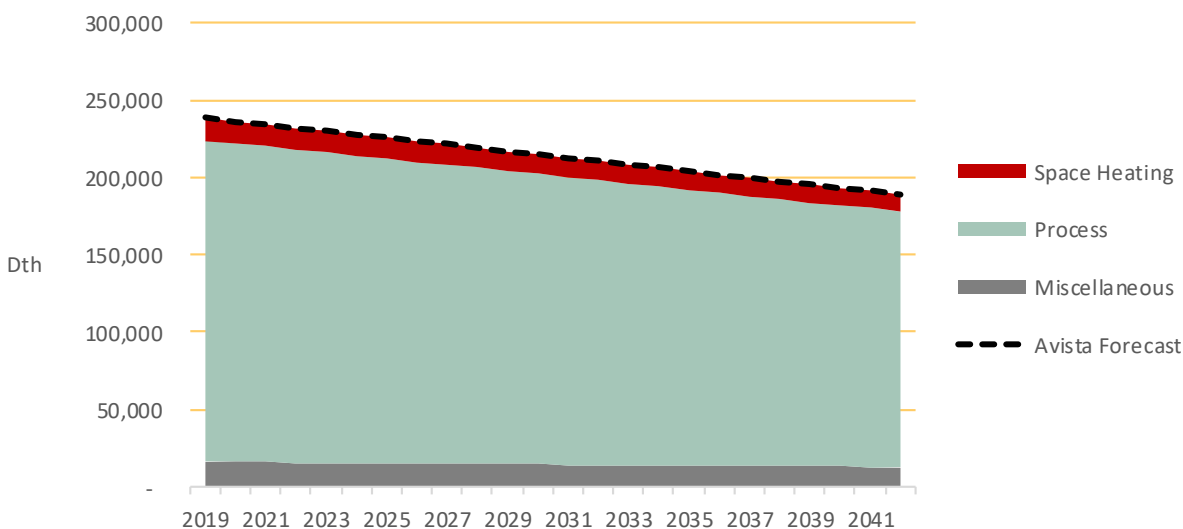

5

OVERALL ENERGY EFFICIENCY POTENTIAL

This chapter presents the measure-level energy conservation potential across all sectors for Avista's Washington and Idaho territories. This includes every possible measure that is considered in the measure list, regardless of program implementation concerns. Year-by-year savings for annual energy usage are available in the LoadMAP model and measure assumption summary, which were provided to Avista at the conclusion of the study. Please note that all savings are provided at the customer site. This section includes potential from the residential, commercial, and industrial analyses.

Overall Energy Efficiency Potential

Washington Potential

Table 5-1 and Figure 5-1 summarize the energy conservation savings in terms of annual energy use for all measures for four levels of potential relative to the baseline projection. Figure 5-2 displays the energy conservation forecasts. Savings are represented in cumulative terms, which reflect the effects of persistent savings in prior years in addition to new savings. This allows for the reporting of annual savings impacts as they actually impact each year of the forecast.

- Technical Potential reflects the adoption of all conservation measures regardless of cost-effectiveness. In this potential case, efficient equipment makes up all lost opportunity installations and all retrofit measures are installed, regardless of achievability. 2021 first-year savings are 421,965 dekatherms, or 2.2% of the baseline projection. Cumulative savings in 2030 are 5,084,999 dekatherms, or 24.7% of the baseline. By 2040, cumulative savings reach 8,908,493 dekatherms, or 41.2% of the baseline. Technical potential is useful as a theoretical construct, applying an upper bound to the potential that may be realized in any one year. Other levels of potential are based off this level which makes it an important component in the estimation of potential.
- Achievable Technical Potential refines technical potential by applying customer participation rates that account for market barriers, customer awareness and attitudes, program maturity, and other factors that affect market penetration of conservation measures. For Avista's gas CPA, ramp rates from the 2021 Power Plan were customized for use in natural gas programs and applied. Since the 2021 Plan does not assign ramp rates for the majority of natural gas measures, we assigned these based on similar electric technologies present in the Plan as a starting point. These ramp rates may be found in Appendix B. 2021 first-year net savings are 187,983 dekatherms, or 1.0% of the baseline projection. Cumulative net savings in 2030 are 3,183,398 dekatherms, or 15.4% of the baseline. By 2040 cumulative savings reach 6,309,826 dekatherms, or 29.2% of the baseline.
- UCT Achievable Economic Potential further refines achievable technical potential by applying an economic cost-effectiveness screen. In this analysis, the cost-effectiveness is measured by the utility cost test (UCT), which compares lifetime energy benefits to the total utility costs of delivering the measure through a utility program, excluding monetized non-energy impacts. Avoided costs of energy were provided by Avista. 2021 first-year savings are 75,820 dekatherms, or 0.4% of the baseline projection. Cumulative savings in 2030 are 1,386,479 dekatherms, or 6.7% of the baseline. By 2040 cumulative savings reach 3,560,512 dekatherms, or 16.5% of the baseline.

- TRC Achievable Economic Potential further refines achievable technical potential by applying an economic cost-effectiveness screen. In this analysis, the cost-effectiveness is measured by the total resource cost (TRC) test, which compares lifetime energy benefits to the total customer and utility costs of delivering the measure through a utility program, including monetized non-energy impacts. AEG also applied benefits for non-gas energy savings, such as electric HVAC savings for weatherization and lighting savings for retrocommissioning. We also applied the Council's calibration credit to space heating savings to reflect the fact that additional fuels may be used as a supplemental heat source within an average home and may be accounted for within the TRC. Avoided costs of energy were provided by Avista. A 10% conservation credit was applied to these costs per the Council methodologies. 2021 first-year savings are 41,871 dekatherms, or 0.2% of the baseline projection. Cumulative net savings in 2030 are 708,778 dekatherms, or 3.4% of the baseline. By 2040 cumulative savings reach 2,319,723 dekatherms, or 10.7% of the baseline. Potential under the TRC test is lower than UCT due to the inclusion of full measure costs rather than the utility portion. For most measures, these far outweigh the quantified and monetized non-energy impacts included in the TRC.

Table 5-1 Summary of Energy Efficiency Potential, Washington (dekatherms)

Scenario	2021	2022	2025	2030	2040
Baseline Projection (Dth)	19,118,293	19,289,575	19,805,020	20,612,516	21,619,876
Cumulative Savings (Dth)					
UCT Achievable Economic Potential	75,820	173,838	457,423	1,386,479	3,560,512
TRC Achievable Economic Potential	41,871	100,872	227,922	708,778	2,319,723
Achievable Technical Potential	187,983	416,584	1,221,810	3,183,398	6,309,826
Technical Potential	429,965	897,098	2,314,334	5,084,999	8,908,493
Cumulative Savings (% of Baseline)					
UCT Achievable Economic Potential	0.4%	0.9%	2.3%	6.7%	16.5%
TRC Achievable Economic Potential	0.2%	0.5%	1.2%	3.4%	10.7%
Achievable Technical Potential	1.0%	2.2%	6.2%	15.4%	29.2%
Technical Potential	2.2%	4.7%	11.7%	24.7%	41.2%

Figure 5-1 Summary of Energy Efficiency Potential as % of Baseline Projection, Washington (dekatherms)

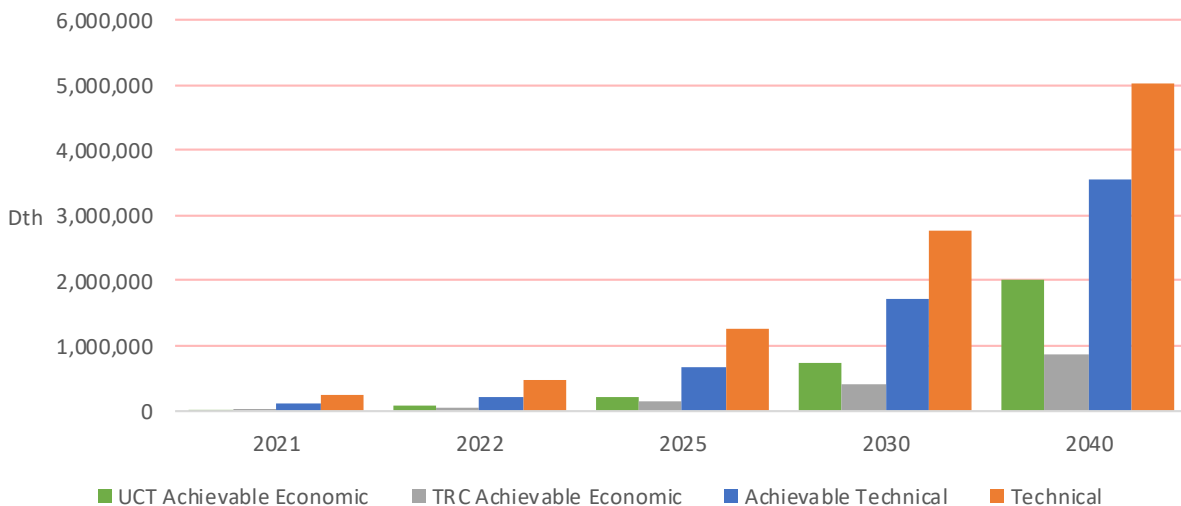

Figure 5-2 Baseline Projection and Energy Efficiency Forecasts, Washington (dekatherms)

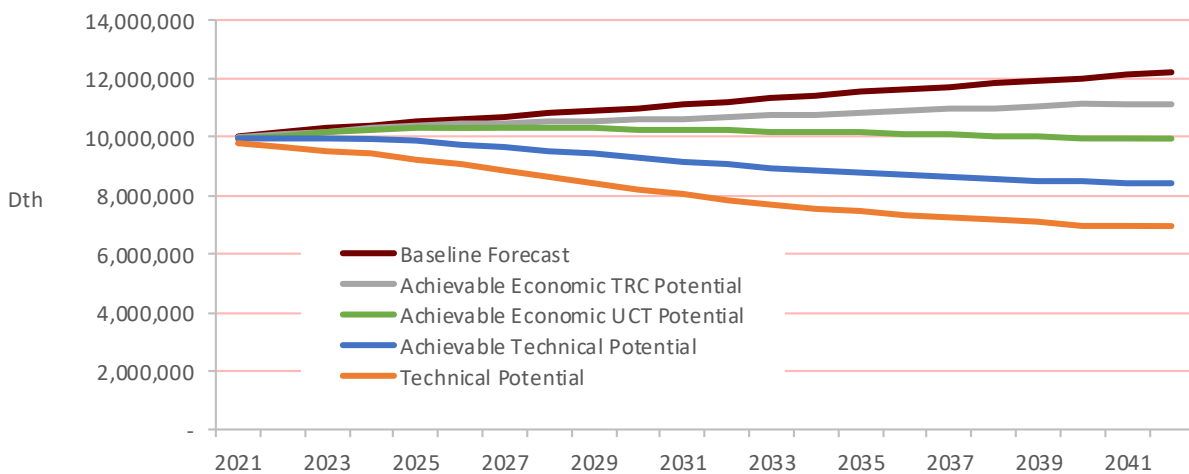

Figure 5-3 shows the cumulative UCT achievable potential by sector for the full timeframe of the analysis as percent of total. Table 5-2 summarizes UCT achievable potential by market sector for selected years.

While the residential and commercial sectors represent the lion’s share of the overall potential in the early years, by the late-2020s, the residential sector share grows to a significant majority of savings potential. Since industrial consumption is such a low percentage of the baseline once ineligible customers have been excluded, potential for this sector makes up a lower percentage of the total. While residential and commercial potential ramps up, industrial potential is mainly retrofit in nature, and is much flatter. This is because process equipment is highly custom and most potential comes from controls modifications or process adjustments rather than high-efficiency equipment upgrades. Additionally, we model retrocommissioning to phase in evenly over the next twenty years. This measure has a maintenance

component, and not all existing facilities may be old enough to require the tune-up immediately but will be eligible at some point over the course of the study.

There is a notable downturn in residential savings around 2024. This is due to the impacts of the residential forced-air furnace standard, which raises the baseline from AFUE 80% to AFUE 92%, which is a substantial increase when the efficient option is an AFUE 95% unit.

Figure 5-3 Cumulative UCT Achievable Economic Potential by Sector, Washington (% of Total)

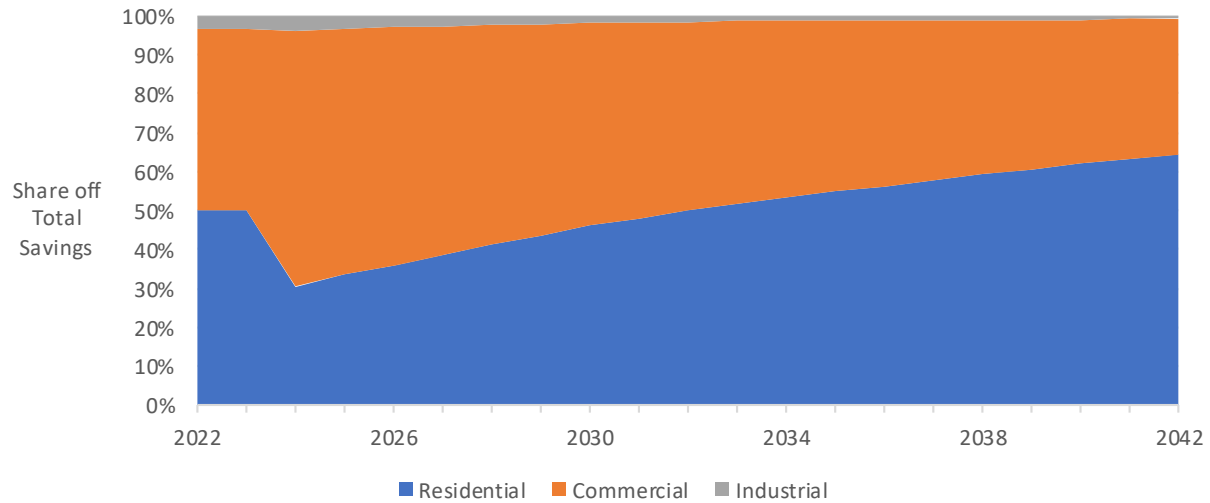

Table 5-2 Cumulative UCT Achievable Economic Potential by Sector, Washington, Selected Years (dekatherms)

Sector	2021	2022	2025	2030	2040
Residential	45,545	102,725	208,449	725,000	2,294,322
Commercial	28,070	66,690	237,773	642,051	1,241,314
Industrial	2,206	4,424	11,200	19,428	24,876
Total	75,820	173,838	457,423	1,386,479	3,560,512

Idaho Potential

Table 5-3 and Figure 5-4 summarize the energy conservation savings in terms of annual energy use for all measures for four levels of potential relative to the baseline projection. Figure 5-5 displays the energy conservation forecasts. Savings are represented in cumulative terms, which reflect the effects of persistent savings in prior years in addition to new savings. This allows for the reporting of annual savings impacts as they actually impact each year of the forecast.

- Technical Potential first-year savings in 2021 are 232,772 dekatherms, or 2.3% of the baseline projection. Cumulative savings in 2030 are 2,777,509 dekatherms, or 25.2% of the baseline. By 2040, cumulative savings reach 5,013,697 dekatherms, or 41.8% of the baseline.
- Achievable Technical Potential first-year net savings are 102,031 dekatherms, or 1.0% of the baseline projection. Cumulative net savings in 2030 are 1,722,830 dekatherms, or 15.7% of the baseline. By 2040 cumulative savings reach 3,544,048 dekatherms, or 29.5% of the baseline.
- UCT Achievable Economic Potential first-year savings are 35,816 dekatherms, or 0.4% of the baseline projection. Cumulative savings in 2030 are 737,710 dekatherms, or 6.7% of the baseline. By 2040 cumulative savings reach 2,025,410 dekatherms, or 16.9% of the baseline.
- TRC Achievable Economic Potential first-year savings are 26,220 dekatherms, or 0.3% of the baseline projection. Cumulative net savings in 2030 are 417,020 dekatherms, or 3.8% of the baseline. By 2040 cumulative savings reach 868,456 dekatherms, or 7.2% of the baseline. Potential under the TRC test is lower than UCT due to the inclusion of full measure costs rather than the utility portion. For most measures, these far outweigh the quantified and monetized non-energy impacts included in the TRC.

Table 5-3 Summary of Energy Efficiency Potential, Idaho (dekatherms)

Scenario	2021	2022	2025	2030	2040
Baseline Projection (Dth)	10,019,377	10,144,894	10,520,169	11,004,568	12,006,819
Cumulative Savings (Dth)					
UCT Achievable Economic Potential	35,816	87,995	229,283	737,710	2,025,410
TRC Achievable Economic Potential	26,220	62,285	136,883	417,028	868,456
Achievable Technical Potential	102,031	226,613	657,997	1,722,830	3,544,048
Technical Potential	232,772	490,826	1,273,202	2,777,509	5,013,697
Cumulative Savings (% of Baseline)					
UCT Achievable Economic Potential	0.4%	0.9%	2.2%	6.7%	16.9%
TRC Achievable Economic Potential	0.3%	0.6%	1.3%	3.8%	7.2%
Achievable Technical Potential	1.0%	2.2%	6.3%	15.7%	29.5%
Technical Potential	2.3%	4.8%	12.1%	25.2%	41.8%

Figure 5-4 Summary of Energy Efficiency Potential as % of Baseline Projection, Idaho (dekatherms)

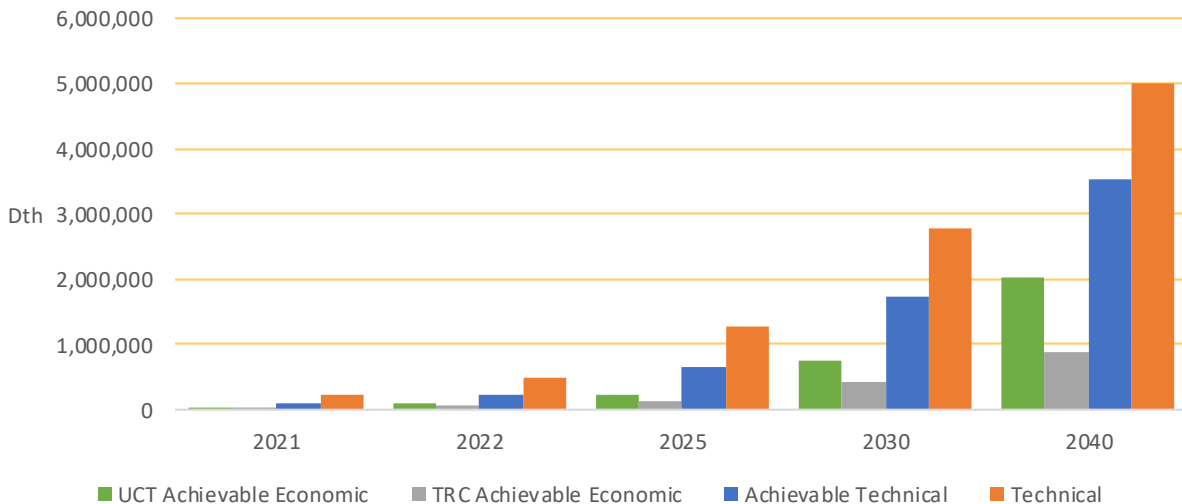

Figure 5-5 Summary of Energy Efficiency Potential as % of Baseline Projection, Idaho (dekatherms)

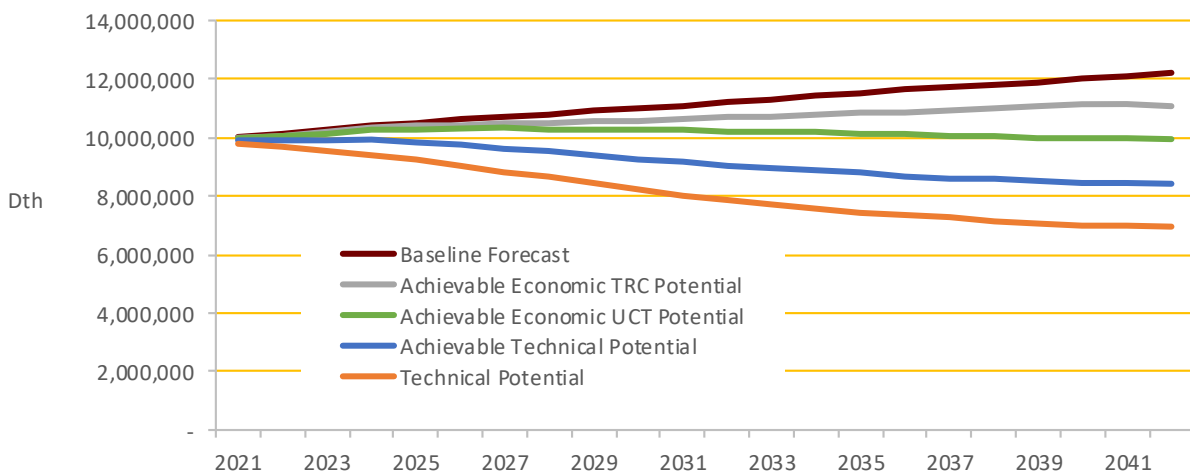

Figure 5-6 shows the cumulative UCT achievable potential by sector for the full timeframe of the analysis as percent of total. Table 5-4 summarizes UCT achievable potential by market sector for selected years.

Figure 5-6 Cumulative UCT Achievable Economic Potential by Sector, Idaho (% of Total)

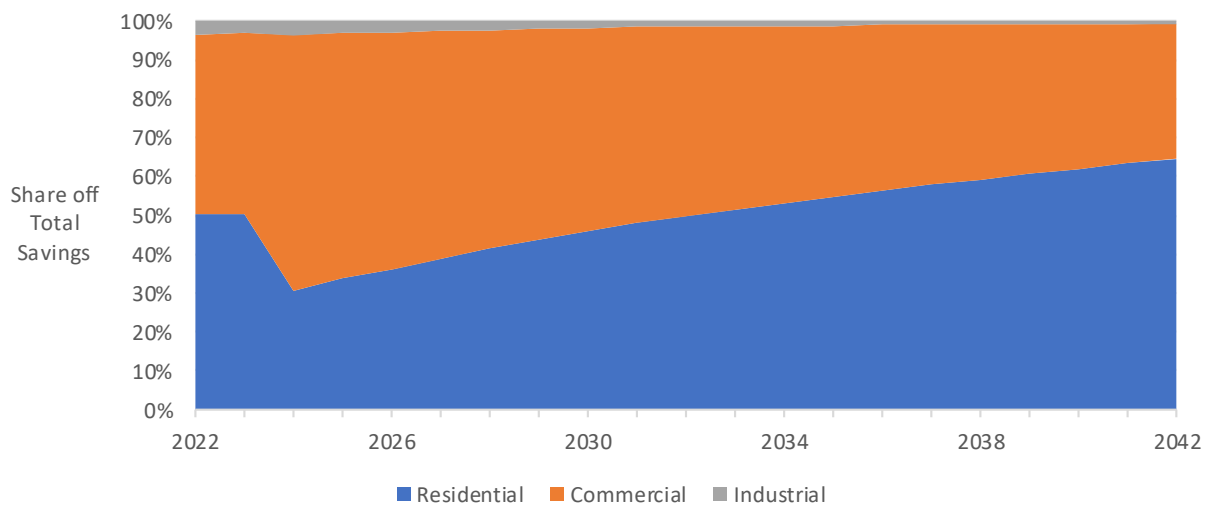

Table 5-4 Cumulative UCT Achievable Economic Potential by Sector, Idaho, Selected Years (dekatherms)

Sector	2021	2022	2025	2030	2040
Residential	17,529	44,289	77,379	339,502	1,256,282
Commercial	16,775	40,676	144,201	384,730	751,926
Industrial	1,512	3,030	7,703	13,477	17,202
Total	35,816	87,995	229,283	737,710	2,025,410

6

SECTOR-LEVEL ENERGY EFFICIENCY POTENTIAL

The previous section provided a summary of potential for the Avista territory at the state level. In this section, we provide details for each sector.

Residential Sector

Washington Potential

Table 6-1 and Figure 6-1 summarize the energy efficiency potential for the residential sector. In 2021, UCT achievable economic potential is 45,545 dekatherms, or 0.4% of the baseline projection. By 2040, cumulative savings are 2,294,322 dekatherms, or 15.9% of the baseline.

Table 6-1 Residential Energy Conservation Potential Summary, Washington (dekatherms)

Scenario	2021	2022	2025	2030	2040
Baseline Forecast (Dth)	12,180,267	12,342,203	12,822,709	13,568,829	14,418,227
Cumulative Savings (Dth)					
UCT Achievable Economic Potential	45,545	102,725	208,449	725,000	2,294,322
TRC Achievable Economic Potential	22,729	53,315	48,069	211,706	1,312,883
Achievable Technical Potential	137,500	304,182	858,976	2,272,407	4,576,510
Technical Potential	292,972	616,103	1,560,420	3,510,309	6,413,126
Energy Savings (% of Baseline)					
UCT Achievable Economic Potential	0.4%	0.8%	1.6%	5.3%	15.9%
TRC Achievable Economic Potential	0.2%	0.4%	0.4%	1.6%	9.1%
Achievable Technical Potential	1.1%	2.5%	6.7%	16.7%	31.7%
Technical Potential	2.4%	5.0%	12.2%	25.9%	44.5%

Figure 6-1 Residential Energy Conservation by Case, Washington (dekatherms)

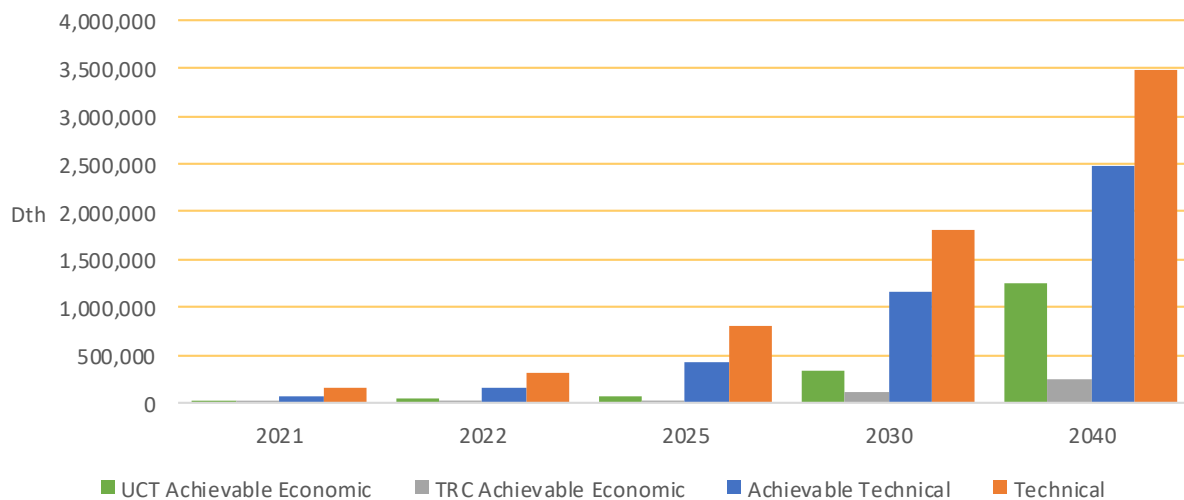

Figure 6-2 presents forecasts of energy savings by end use as a percent of total annual savings and cumulative savings. Space heating makes up a majority of potential but declines slightly in the early to mid-2020s due to the future furnace standard.

Figure 6-2 Residential UCT Achievable Economic Potential – Cumulative Savings by End Use, Washington (dekatherms, % of total)

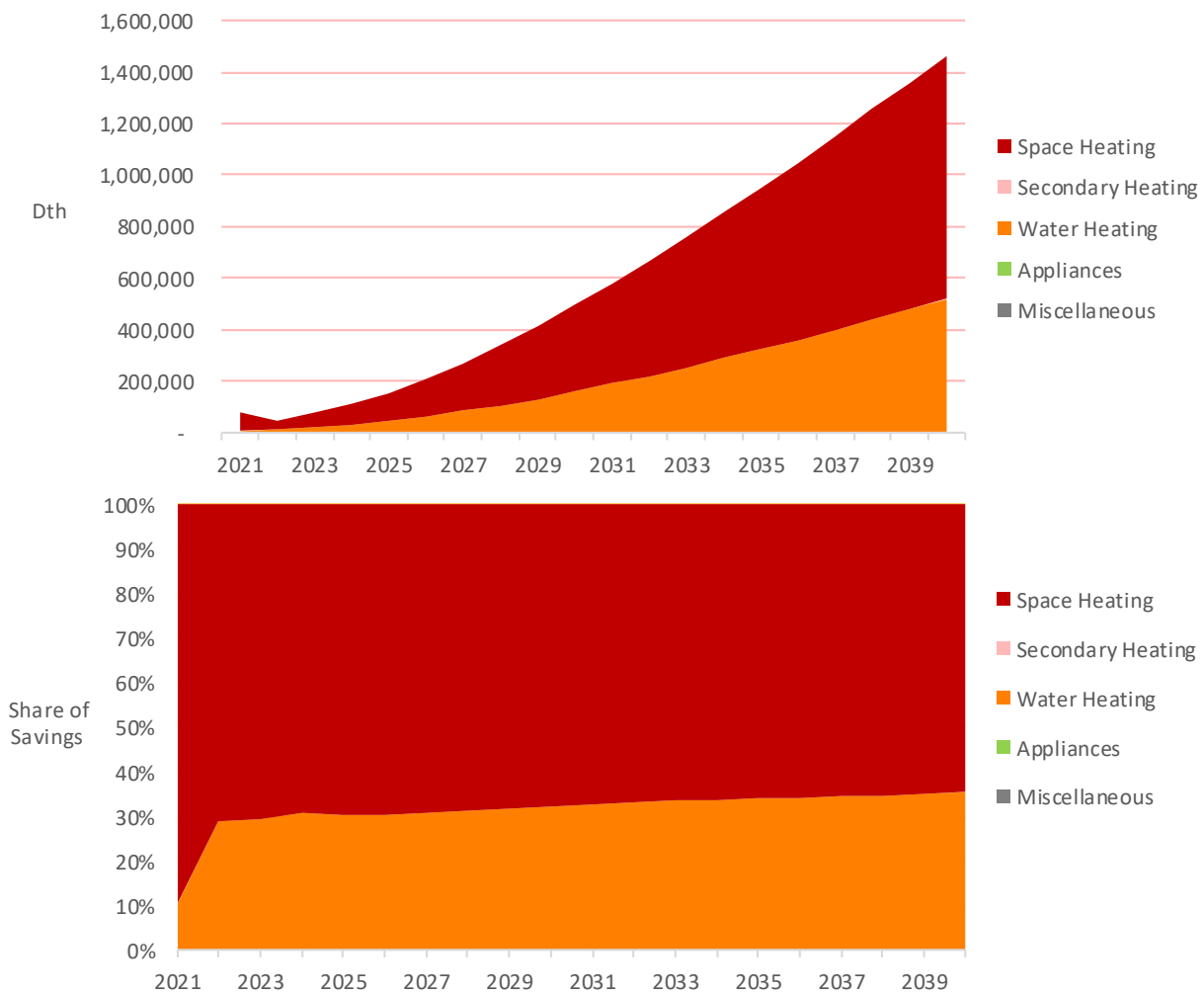

Table 6-2 identifies the top 20 residential measures by cumulative 2021 and 2022 savings. Furnaces, learning thermostats, insulation and water heating are the top measures.

Table 6-2 Residential Top Measures in 2021 and 2022, UCT Achievable Economic Potential, Washington (dekatherms)

Rank	Measure / Technology	2021 Cumulative Potential Savings (dekatherms)	% of Total	2022 Cumulative Potential Savings (dekatherms)	% of Total
1	Furnace - AFUE 92%	21,548	47%	50,231	49%
2	Gas Furnace - Maintenance - Restored to nameplate 80% AFUE	13,118	29%	26,107	25%
3	ENERGY STAR Connected Thermostat - Interactive/learning thermostat (ie, NEST)	4,435	10%	9,925	10%
4	Insulation - Ceiling, Installation - R-38 (Retro only)	3,611	8%	8,000	8%
5	Water Heater - Instantaneous - ENERGY STAR (UEF 0.87)	1,901	4%	5,973	6%
6	Insulation - Wall Cavity, Installation - R-11	333	1%	741	1%
7	Gas Boiler - Steam Trap Maintenance - Cleaned and restored	202	0%	399	0%
8	Building Shell - Whole-Home Aerosol Sealing - 20% reduction in ACH50	163	0%	492	0%
9	Water Heater - Low Flow Showerhead (1.5 GPM) - 1.5 GPM showerhead	75	0%	194	0%
10	Boiler - AFUE 85%	51	0%	130	0%
11	Water Heater - Faucet Aerators - 1.5 GPM faucet	51	0%	131	0%
12	ENERGY STAR Homes - Built Green spec (NC Only)	47	0%	265	0%
13	Water Heater - Pipe Insulation - Insulated 5' of pipe between unit and conditioned space	10	0%	25	0%
14	Insulation - Slab Foundation - R-11 (NC Only)	0	0%	23	0%
15	Building Shell - Liquid-Applied Weather-Resistive Barrier - Spray-on weather barrier applied	0	0%	0	0%
16	Clothes Dryer - NEEA/ENERGY STAR (CE >60%)	0	0%	0	0%
17	Combined Boiler + DHW System (Storage Tank) - Combined tankless boiler unit for space and DHW	0	0%	0	0%
18	Combined Boiler + DHW System (Tankless) - Combined tankless boiler unit for space and DHW	0	0%	0	0%
19	Doors - Storm and Thermal - R-5 door	0	0%	0	0%
20	Ducting - Repair and Sealing - 50% reduction in duct leakage	0	0%	0	0%
Subtotal		45,545	100%	102,636	100%
Total Savings in Year		45,545	100%	102,725	100%

Idaho Potential

Table 6-3 and Figure 6-3 summarize the energy efficiency potential for the residential sector. In 2021, UCT achievable economic potential is 17,529 dekatherms, or 0.3% of the baseline projection. By 2040, cumulative savings are 1,256,282 dekatherms, or 16.5% of the baseline.

Table 6-3 Residential Energy Conservation Potential Summary, Idaho (dekatherms)

Scenario	2021	2022	2025	2030	2040
Baseline Forecast (Dth)	5,757,753	5,864,931	6,201,524	6,677,657	7,614,162
Cumulative Savings (Dth)					
UCT Achievable Economic Potential	17,529	44,289	77,379	339,502	1,256,282
TRC Achievable Economic Potential	14,700	32,896	26,285	117,618	255,801
Achievable Technical Potential	70,759	156,239	432,644	1,167,372	2,486,556
Technical Potential	148,844	313,749	798,652	1,806,313	3,485,609
Energy Savings (% of Baseline)					
UCT Achievable Economic Potential	0.3%	0.8%	1.2%	5.1%	16.5%
TRC Achievable Economic Potential	0.3%	0.6%	0.4%	1.8%	3.4%
Achievable Technical Potential	1.2%	2.7%	7.0%	17.5%	32.7%
Technical Potential	2.6%	5.3%	12.9%	27.1%	45.8%

Figure 6-3 Residential Energy Conservation by Case, Idaho (dekatherms)

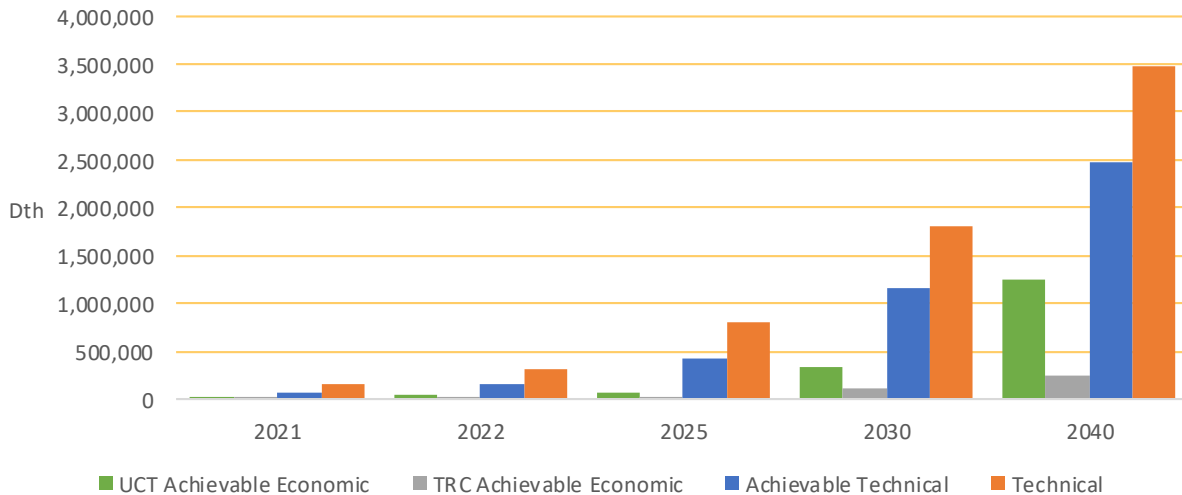

Figure 6-4 presents forecasts of energy savings by end use as a percent of total annual savings and cumulative savings. Space heating makes up a majority of potential but declines slightly in the early to mid-2020s due to the future furnace standard.

Figure 6-4 Residential UCT Achievable Economic Potential – Cumulative Savings by End Use, Idaho (dekatherms, % of total)

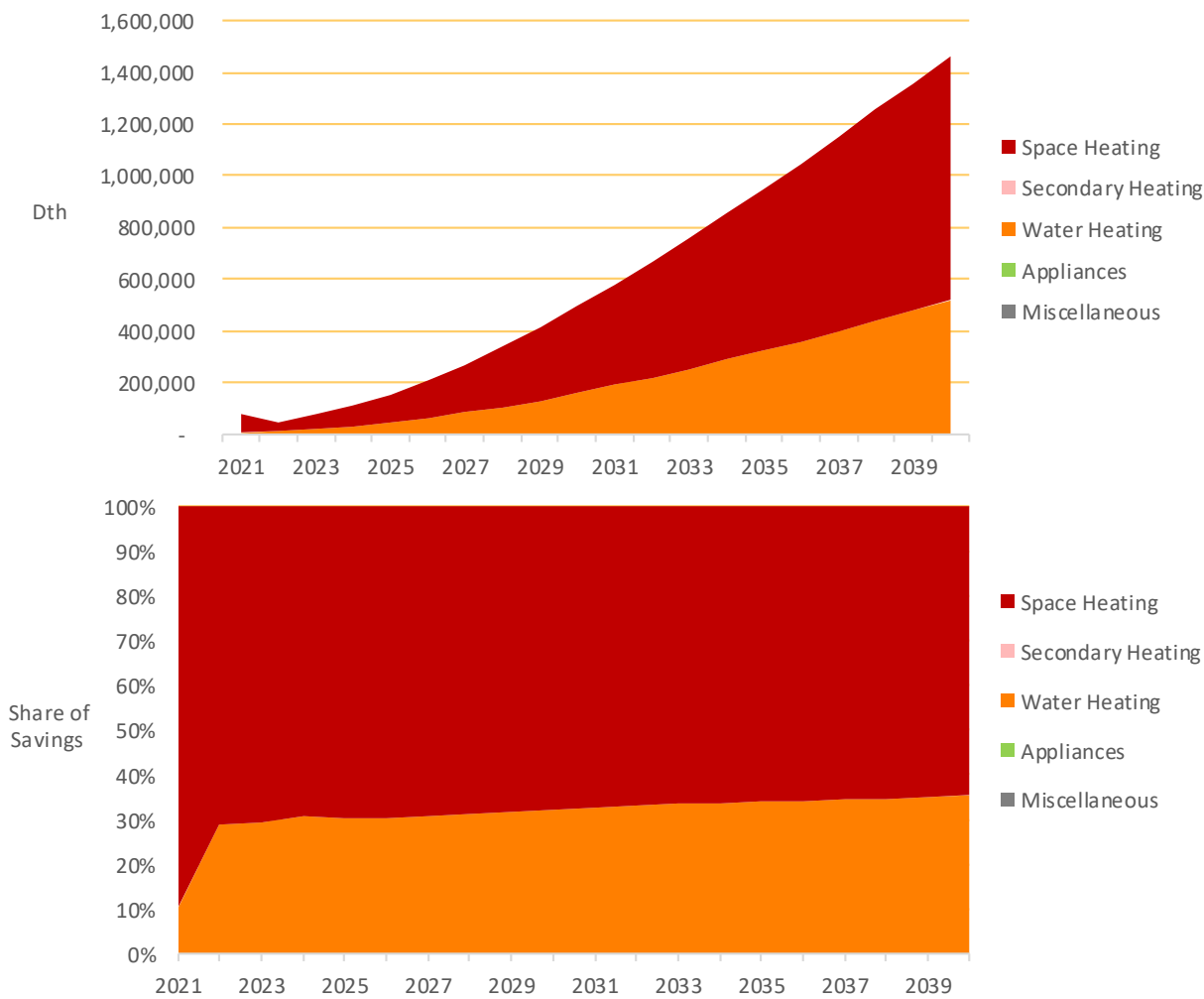

Table 6-4 identifies the top 20 residential measures by cumulative 2018 and 2019 savings. Furnaces, tankless water heaters, windows, and insulation are the top measures.

Table 6-4 Residential Top Measures in 2021 and 2022, UCT Achievable Economic Potential, Idaho (dekatherms)

Rank	Measure / Technology	2021 Cumulative Potential Savings (dekatherms)	% of Total	2022 Cumulative Potential Savings (dekatherms)	% of Total
1	Furnace - AFUE 92%	14,054	80%	31,241	71%
2	Insulation - Ceiling, Installation - R-38 (Retro only)	1,643	9%	3,640	8%
3	Water Heater - Instantaneous - ENERGY STAR (UEF 0.87)	1,053	6%	3,293	7%
4	Gas Furnace - Maintenance - Restored to nameplate 80% AFUE	284	2%	4,805	11%
5	Insulation - Wall Cavity, Installation - R-11	142	1%	316	1%
6	Water Heater - Low Flow Showerhead (1.5 GPM) - 1.5 GPM showerhead	93	1%	243	1%
7	Gas Boiler - Steam Trap Maintenance - Cleaned and restored	91	1%	180	0%
8	Building Shell - Whole-Home Aerosol Sealing - 20% reduction in ACH50	79	0%	237	1%
9	ENERGY STAR Homes - Built Green spec (NC Only)	32	0%	176	0%
10	Water Heater - Faucet Aerators - 1.5 GPM faucet	32	0%	87	0%
11	Water Heater - Low Flow Showerhead (2.0 GPM) - 2.0 GPM showerhead	21	0%	56	0%
12	Water Heater - Pipe Insulation - Insulated 5' of pipe between unit and conditioned space	5	0%	14	0%
Subtotal		17,529	100%	44,289	100%
Total Savings in Year		17,529	100%	44,289	100%

Commercial Sector

Washington Potential

Table 6-5 and Figure 6-5 summarize the energy conservation potential for the commercial sector. In 2021, UCT achievable economic potential is 28,070 dekatherms, or 0.4% of the baseline projection. By 2040, cumulative savings are 1,241,314 dekatherms, or 18.0% of the baseline.

Table 6-5 Commercial Energy Conservation Potential Summary, Washington

Scenario	2021	2022	2025	2030	2040
Baseline Forecast (dekatherms)	6,596,157	6,608,411	6,651,275	6,725,824	6,909,984
Cumulative Savings (dekatherms)					
UCT Achievable Economic Potential	28,070	66,690	237,773	642,051	1,241,314
TRC Achievable Economic Potential	18,820	46,887	177,954	492,563	999,201
Achievable Technical Potential	47,867	107,183	349,669	887,910	1,704,037
Technical Potential	133,767	274,570	737,799	1,546,608	2,459,821
Energy Savings (% of Baseline)					
UCT Achievable Economic Potential	0.4%	1.0%	3.6%	9.5%	18.0%
TRC Achievable Economic Potential	0.3%	0.7%	2.7%	7.3%	14.5%
Achievable Technical Potential	0.7%	1.6%	5.3%	13.2%	24.7%
Technical Potential	2.0%	4.2%	11.1%	23.0%	35.6%

Figure 6-5 Commercial Energy Conservation by Case, Washington (dekatherms)

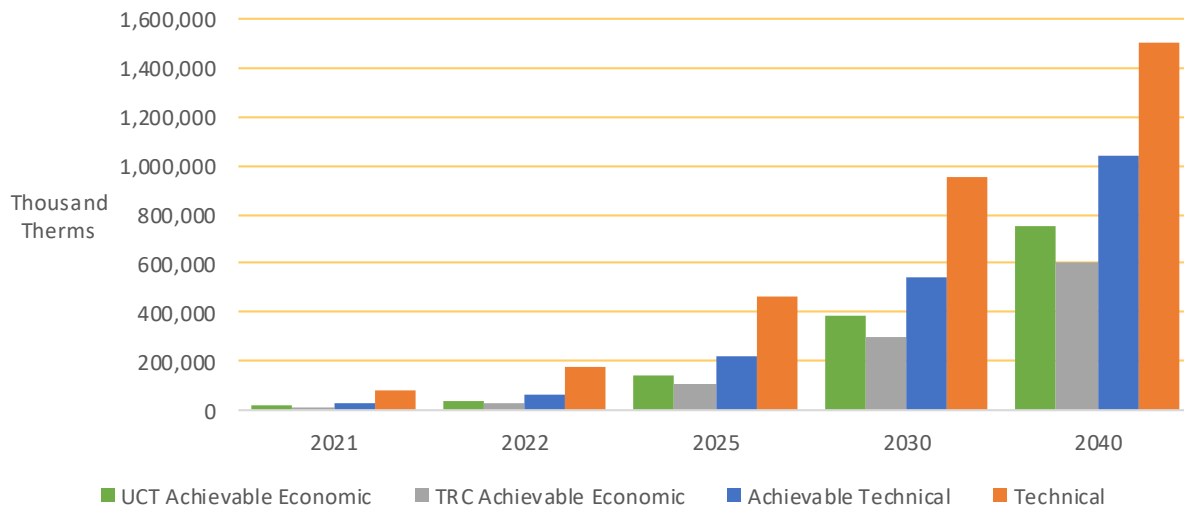

Figure 6-6 presents forecasts of energy savings by end use as a percent of total annual savings and cumulative savings. Space heating makes up a majority of the potential early, but food preparation equipment upgrades provide substantial savings opportunities in the later years.

Figure 6-6 Commercial UCT Achievable Economic Potential – Cumulative Savings by End Use, Washington (dekatherms, % of total)

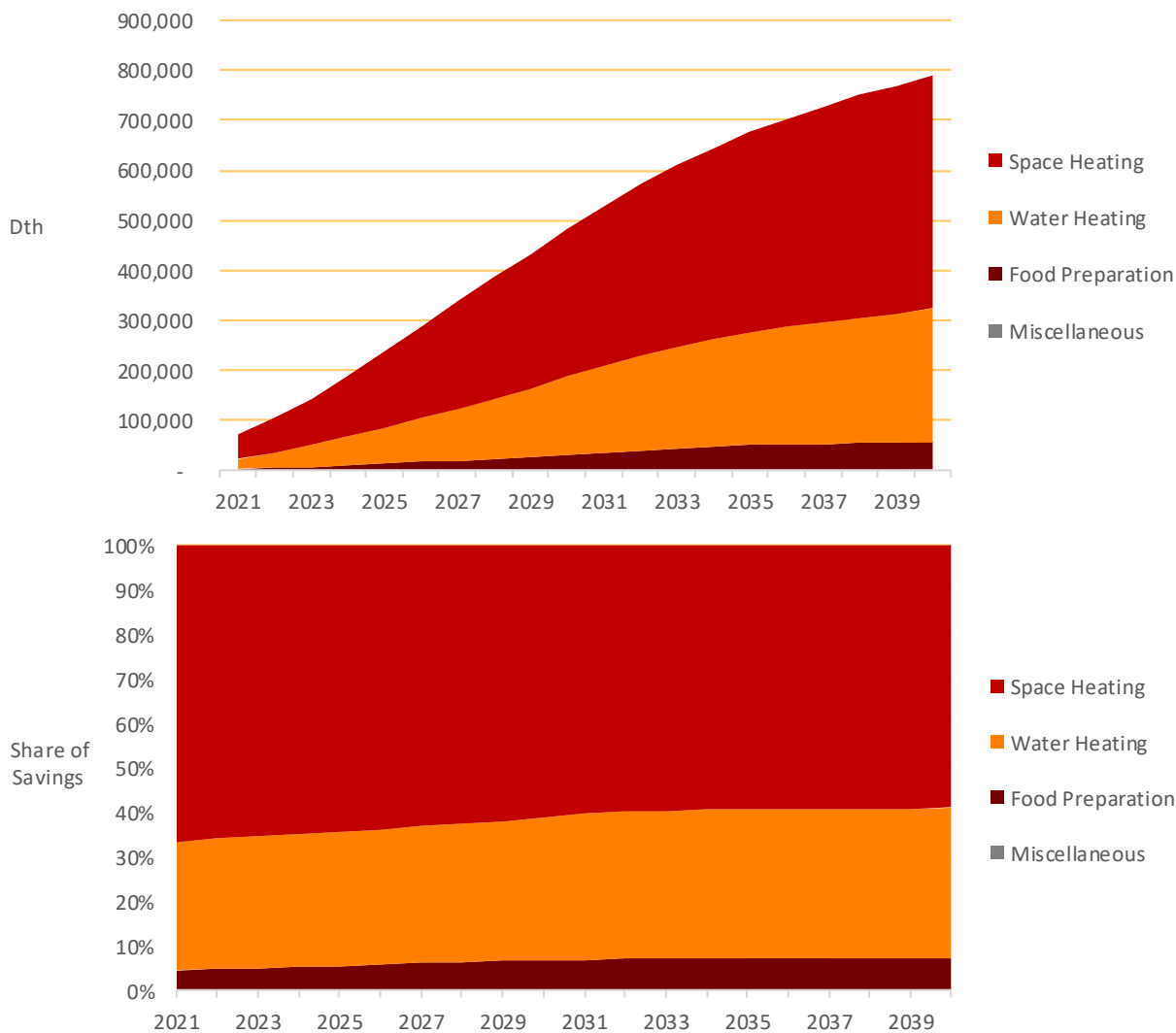

Table 6-6 identifies the top 20 commercial measures by cumulative savings in 2021 and 2022. Heat Pump Water Heaters are the top measure, followed by several HVAC and space heating measures, along with insulation.

Table 6-6 Commercial Top Measures in 2021 and 2022, UCT Achievable Economic Potential, Washington (dekatherms)

Rank	Measure / Technology	2018 Cumulative Potential Savings (dekatherms)	% of Total	2019 Cumulative Potential Savings (dekatherms)	% of Total
1	Water Heater - Gas-Fired Absorption HPWH	5,714	20%	15,883	24%
2	Space Heating - Heat Recovery Ventilator - HRV installed	4,763	17%	9,542	14%
3	Boiler - AFUE 97%	4,136	15%	10,378	16%
4	HVAC - Duct Repair and Sealing - 30% reduced duct leaking	2,323	8%	4,589	7%
5	Insulation - Wall Cavity - R-21	2,059	7%	5,578	8%
6	Insulation - Roof/Ceiling - R-38	1,584	6%	4,318	6%
7	Gas Boiler - Insulate Steam Lines/Condensate Tank - Lines and condensate tank insulated	1,456	5%	2,871	4%
8	Water Heater - Central Controls - Central water boiler controls installed	1,267	5%	2,508	4%
9	Gas Boiler - Hot Water Reset - Reset control installed	1,127	4%	2,476	4%
10	Gas Boiler - High Turndown - Turndown control installed	766	3%	1,509	2%
11	Fryer - ENERGY STAR	751	3%	1,800	3%
12	Water Heater - Faucet Aerator - 1.5 GPM faucet	362	1%	791	1%
13	Building Automation System - Automation system installed and programmed	360	1%	1,059	2%
14	Kitchen Hood - DCV/MUA - DCV/HUA vent hood	316	1%	629	1%
15	HVAC - Demand Controlled Ventilation - DCV enabled	227	1%	539	1%
16	Furnace - AFUE 96%	129	0%	426	1%
17	Gas Furnace - Maintenance - General cleaning and maintenance	125	0%	211	0%
18	Double Rack Oven - FTSC Qualified (>50% Cooking Efficiency)	96	0%	257	0%
19	Steam Trap Maintenance - Cleaning and maintenance	78	0%	153	0%
20	Oven - ENERGY STAR (>42% Baking Efficiency)	74	0%	196	0%
Subtotal		27,713	99%	65,714	99%
Total Savings in Year		28,070	100%	66,690	100%

Idaho Potential

Table 6-7 and Figure 6-7 summarize the energy conservation potential for the commercial sector. In 2021, UCT achievable economic potential is 16,775 dekatherms, or 0.4% of the baseline projection. By 2040, cumulative savings are 751,926 dekatherms, or 17.9% of the baseline.

Table 6-7 Commercial Energy Conservation Potential Summary, Idaho

Scenario	2021	2022	2025	2030	2040
Baseline Forecast (dekatherms)	4,027,575	4,047,905	4,093,096	4,112,209	4,199,550
Cumulative Savings (dekatherms)					
UCT Achievable Economic Potential	16,775	40,676	144,201	384,730	751,926
TRC Achievable Economic Potential	11,301	28,926	109,041	295,643	606,619
Achievable Technical Potential	29,482	66,801	216,357	539,726	1,037,584
Technical Potential	81,719	172,678	463,550	952,082	1,503,965
Energy Savings (% of Baseline)					
UCT Achievable Economic Potential	0.4%	1.0%	3.5%	9.4%	17.9%
TRC Achievable Economic Potential	0.3%	0.7%	2.7%	7.2%	14.4%
Achievable Technical Potential	0.7%	1.7%	5.3%	13.1%	24.7%
Technical Potential	2.0%	4.3%	11.3%	23.2%	35.8%

Figure 6-7 Commercial Energy Conservation by Case, Idaho (dekatherms)

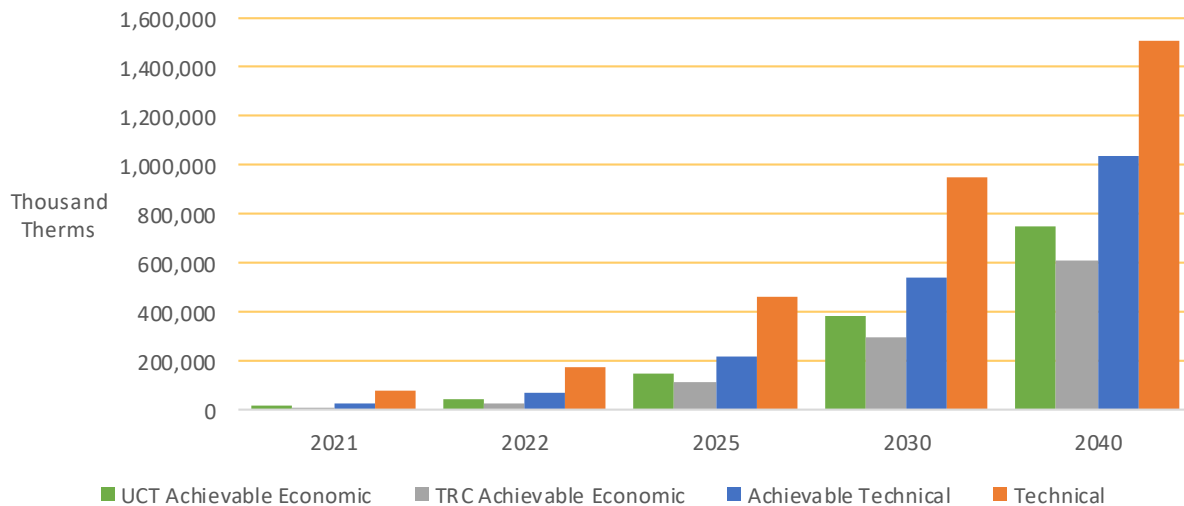

Figure 6-8 presents forecasts of energy savings by end use as a percent of total annual savings and cumulative savings. Space heating makes up a majority of the potential early, but food preparation equipment upgrades provide substantial savings opportunities in the later years.

Figure 6-8 Commercial UCT Achievable Economic Potential – Cumulative Savings by End Use, Idaho (dekatherms, % of total)

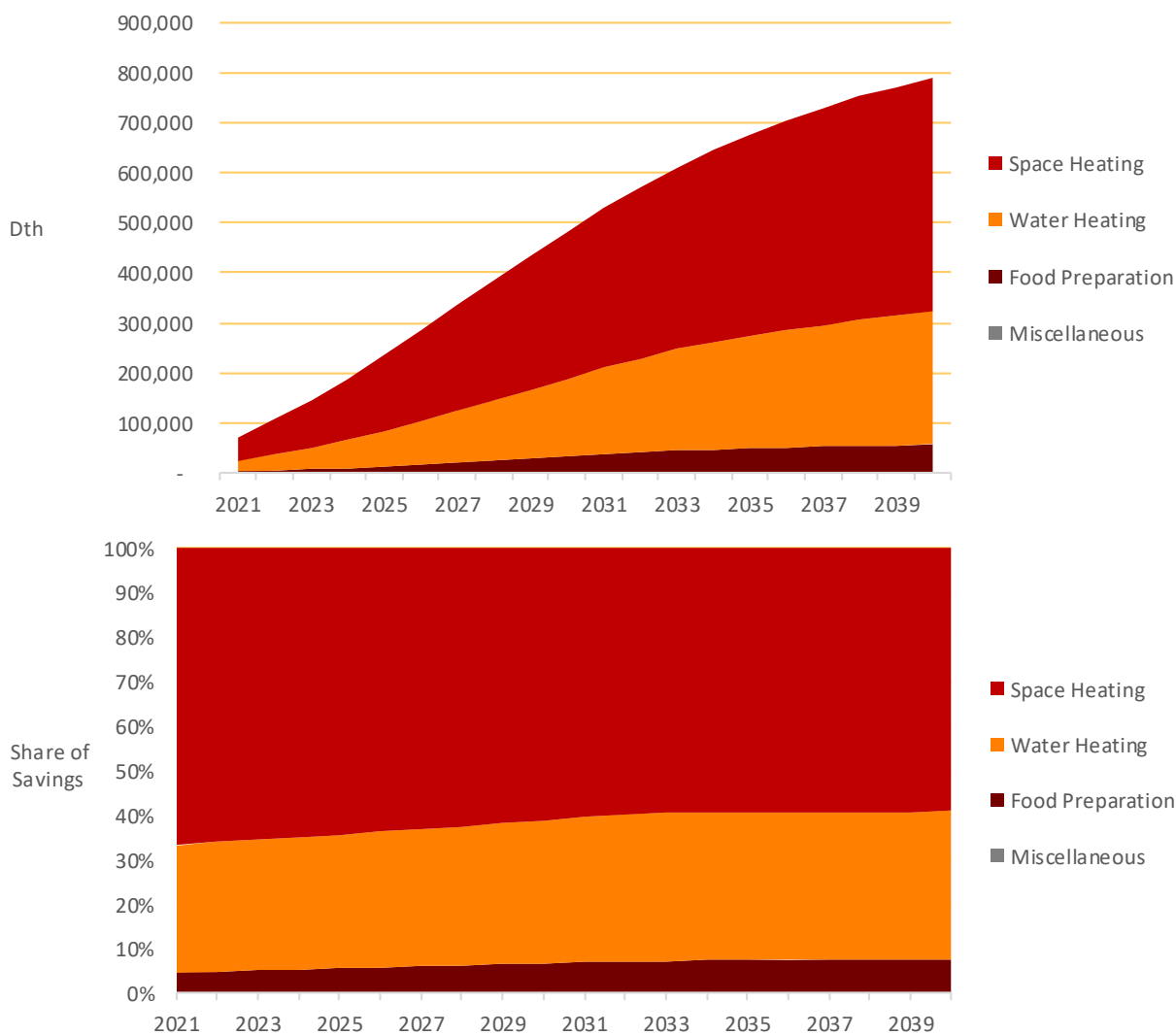

Table 6-8 identifies the top 20 commercial measures by cumulative savings in 2021 and 2022. Water Heaters are the top measure, followed by custom HVAC measures and insulation.

Table 6-8 Commercial Top Measures in 2021 and 2022, UCT Achievable Economic Potential, Idaho (dekatherms)

Rank	Measure / Technology	2021 Cumulative Potential Savings (dekatherms)	% of Total	2022 Cumulative Potential Savings (dekatherms)	% of Total
1	Water Heater - Gas-Fired Absorption HPWH	3,140	19%	9,188	23%
2	Space Heating - Heat Recovery Ventilator - HRV installed	2,806	17%	5,620	14%
3	Boiler - AFUE 97%	2,507	15%	6,733	17%
4	HVAC - Duct Repair and Sealing - 30% reduced duct leaking	1,454	9%	2,872	7%
5	Insulation - Wall Cavity - R-21	1,279	8%	3,464	9%
6	Gas Boiler - Insulate Steam Lines/Condensate Tank - Lines and condensate tank insulated	1,062	6%	2,094	5%
7	Insulation - Roof/Ceiling - R-38	924	6%	2,506	6%
8	Gas Boiler - Hot Water Reset - Reset control installed	695	4%	1,526	4%
9	Water Heater - Central Controls - Central water boiler controls installed	634	4%	1,258	3%
10	Gas Boiler - High Turndown - Turndown control installed	465	3%	915	2%
11	Fryer - ENERGY STAR	458	3%	1,145	3%
12	Building Automation System - Automation system installed and programmed	230	1%	676	2%
13	Water Heater - Faucet Aerator - 1.5 GPM faucet	218	1%	477	1%
14	Kitchen Hood - DCV/MUA - DCV/HUA vent hood	214	1%	426	1%
15	HVAC - Demand Controlled Ventilation - DCV enabled	142	1%	334	1%
16	Furnace - AFUE 96%	89	1%	304	1%
17	Gas Furnace - Maintenance - General cleaning and maintenance	78	0%	132	0%
18	Double Rack Oven - FTSC Qualified (>50% Cooking Efficiency)	67	0%	186	0%
19	Steam Trap Maintenance - Cleaning and maintenance	55	0%	109	0%
20	Oven - ENERGY STAR (>42% Baking Efficiency)	52	0%	141	0%
Subtotal		16,567	99%	40,107	99%
Total Savings in Year		16,775	100%	40,676	100%

Industrial Sector

Washington Potential

Table 6-9 and Figure 6-9 summarize the energy conservation potential for the core industrial sector. In 2021, UCT achievable economic potential is 2,206 dekatherms, or 0.6% of the baseline projection. By 2040, cumulative savings reach 24,876 dekatherms, or 8.5% of the baseline. Industrial potential is a lower percentage of overall baseline compared to the residential and commercial sectors. While large, custom process optimization and controls measures are present in potential, these are not applicable to all processes which limits potential at the technical level. Additionally, since the largest customers were excluded from this analysis due to their status as transport-only customers making them ineligible to participate in energy efficiency programs for the utility, the remaining customers are smaller and tend to have lower process end-use shares, further lowering industrial potential. As seen in the figure below, industrial potential is substantially lower due to the smaller sector size and process uses.

Table 6-9 Industrial Energy Conservation Potential Summary, Washington (dekatherms)

Scenario	2021	2022	2025	2030	2040
Baseline Forecast (dekatherms)	341,870	338,961	331,037	317,863	291,665
Cumulative Savings (dekatherms)					
UCT Achievable Economic Potential	2,206	4,424	11,200	19,428	24,876
TRC Achievable Economic Potential	321	669	1,899	4,508	7,639
Achievable Technical Potential	2,616	5,219	13,165	23,081	29,280
Technical Potential	3,226	6,425	16,116	28,082	35,546
Energy Savings (% of Baseline)					
UCT Achievable Economic Potential	0.6%	1.3%	3.4%	6.1%	8.5%
TRC Achievable Economic Potential	0.1%	0.2%	0.6%	1.4%	2.6%
Achievable Technical Potential	0.8%	1.5%	4.0%	7.3%	10.0%
Technical Potential	0.9%	1.9%	4.9%	8.8%	12.2%

Figure 6-9 Industrial Energy Conservation Potential, Washington (dekatherms)

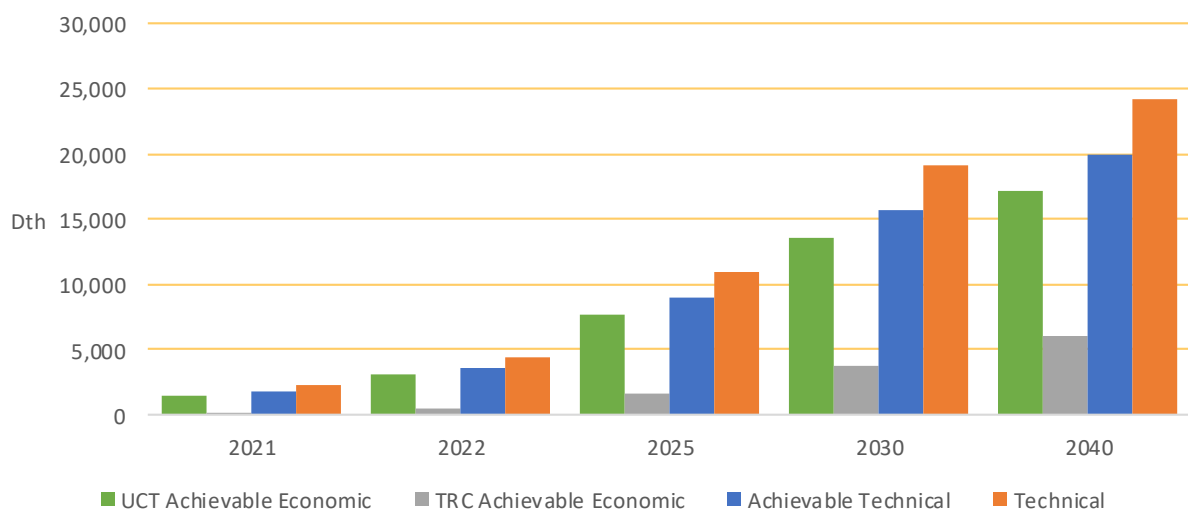

Figure 6-10 presents forecasts of energy savings by end use as a percent of total annual savings and cumulative savings.

Figure 6-10 Industrial UCT Achievable Economic Potential – Cumulative Savings by End Use, Washington (dekatherms, % of total)

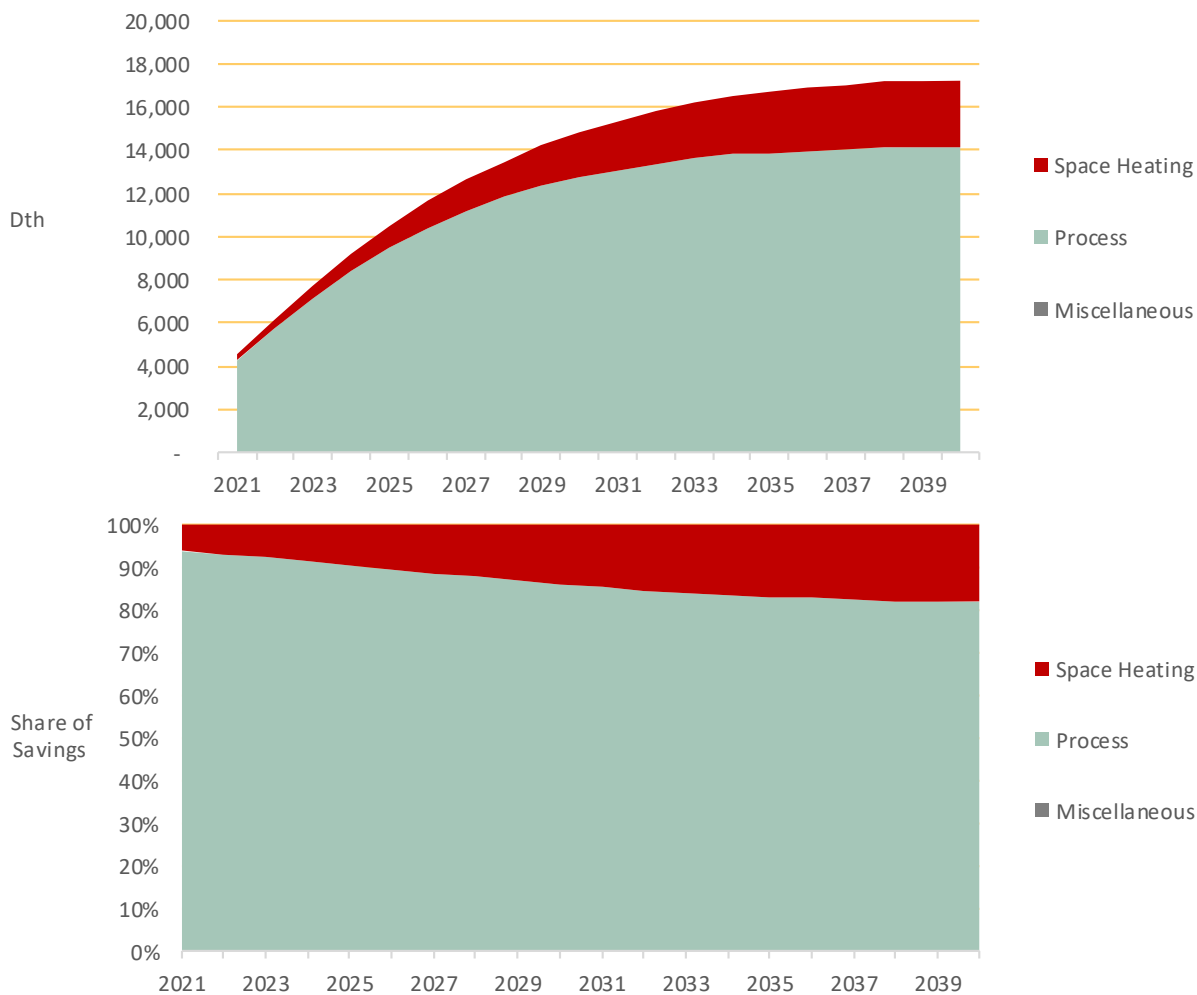

Table 6-10 identifies the top 20 industrial measures by cumulative 2021 and 2022 savings. Process Heat Recovery and Retrocommissioning optimization measures have the largest potential savings. Process Heat Recovery alone accounts for more than 70% of 2021-2022 industrial potential in Washington.

Table 6-10 Industrial Top Measures in 2021 and 2022, UCT Achievable Economic Potential, Washington (dekatherms)

Rank	Measure / Technology	2021 Cumulative Potential Savings (dekatherms)	% of Total	2022 Cumulative Potential Savings (dekatherms)	% of Total
1	Process Heat Recovery - HR system installed	1,691	72%	3,366	71%
2	Retrocommissioning - Optimized HVAC flow and controls	156	7%	306	6%
3	Retrocommissioning - Optimized process design and controls	156	7%	306	6%
4	Gas Boiler - High Turndown - Turndown control installed	112	5%	222	5%
5	Gas Boiler - Hot Water Reset - Reset control installed	111	5%	244	5%
6	Destratification Fans (HVLS) - Fans installed	40	2%	79	2%
7	Gas Boiler - Insulate Steam Lines/Condensate Tank - Lines and condensate tank insulated	28	1%	55	1%
8	Gas Boiler - Insulate Hot Water Lines - Insulated water lines	19	1%	37	1%
9	ENERGY STAR Connected Thermostat - Wi-Fi/interactive thermostat installed	17	1%	34	1%
10	Space Heating - Heat Recovery Ventilator - HRV installed	15	1%	30	1%
11	Boiler - AFUE 97%	5	0%	14	0%
12	Insulation - Wall Cavity - R-21	4	0%	10	0%
13	Furnace - AFUE 96%	3	0%	10	0%
14	Gas Furnace - Maintenance - General cleaning and maintenance	2	0%	4	0%
15	Thermostat - Programmable - Programmable thermostat installed	2	0%	4	0%
16	Steam Trap Maintenance - Cleaning and maintenance	1	0%	1	0%
17	Unit Heater - Infrared Radiant	0	0%	1	0%
18	Insulation - Roof/Ceiling - R-38	0	0%	0	0%
Subtotal		2,362	100%	4,725	100%
Total Savings in Year		2,362	100%	4,730	100%

Idaho Potential

Table 6-11 and Figure 6-11 summarize the energy conservation potential for the core industrial sector. In 2021, UCT achievable economic potential is 1,512 dekatherms, or 0.6% of the baseline projection. By 2040, cumulative savings reach 19,908 dekatherms, or 10.3% of the baseline. Industrial potential is a lower percentage of overall baseline compared to the residential and commercial sectors. While large, custom process optimization and controls measures are present in potential, these are not applicable to all processes which limits potential at the technical level. Additionally, since the largest customers were excluded from this analysis due to their status as transport-only customers making them ineligible to participate in energy efficiency programs for the utility, the remaining customers are smaller and tend to have lower process end-use shares, further lowering industrial potential. As seen in the figure below, industrial potential is substantially lower due to the smaller sector size and process uses.

Table 6-11 Industrial Energy Conservation Potential Summary, Idaho (dekatherms)

Scenario	2021	2022	2025	2030	2040
Baseline Forecast (dekatherms)	234,049	232,058	225,549	214,701	193,107
Cumulative Savings (dekatherms)					
UCT Achievable Economic Potential	1,512	3,030	7,703	13,477	17,202
TRC Achievable Economic Potential	220	463	1,557	3,767	6,036
Achievable Technical Potential	1,791	3,573	8,996	15,731	19,908
Technical Potential	2,209	4,398	11,000	19,113	24,123
Energy Savings (% of Baseline)					
UCT Achievable Economic Potential	0.6%	1.3%	3.4%	6.3%	8.9%
TRC Achievable Economic Potential	0.1%	0.2%	0.7%	1.8%	3.1%
Achievable Technical Potential	0.8%	1.5%	4.0%	7.3%	10.3%
Technical Potential	0.9%	1.9%	4.9%	8.9%	12.5%

Figure 6-11 Industrial Energy Conservation Potential, Idaho (dekatherms)

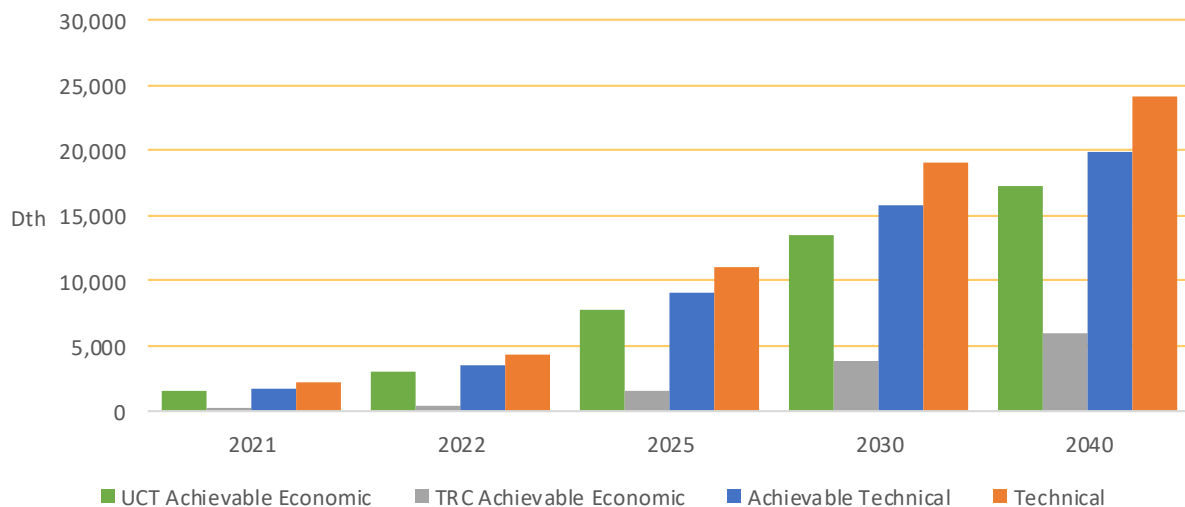

Figure 6-12 presents forecasts of energy savings by end use as a percent of total annual savings and cumulative savings.

Figure 6-12 Industrial UCT Achievable Economic Potential – Cumulative Savings by End Use, Idaho (dekatherms, % of total)

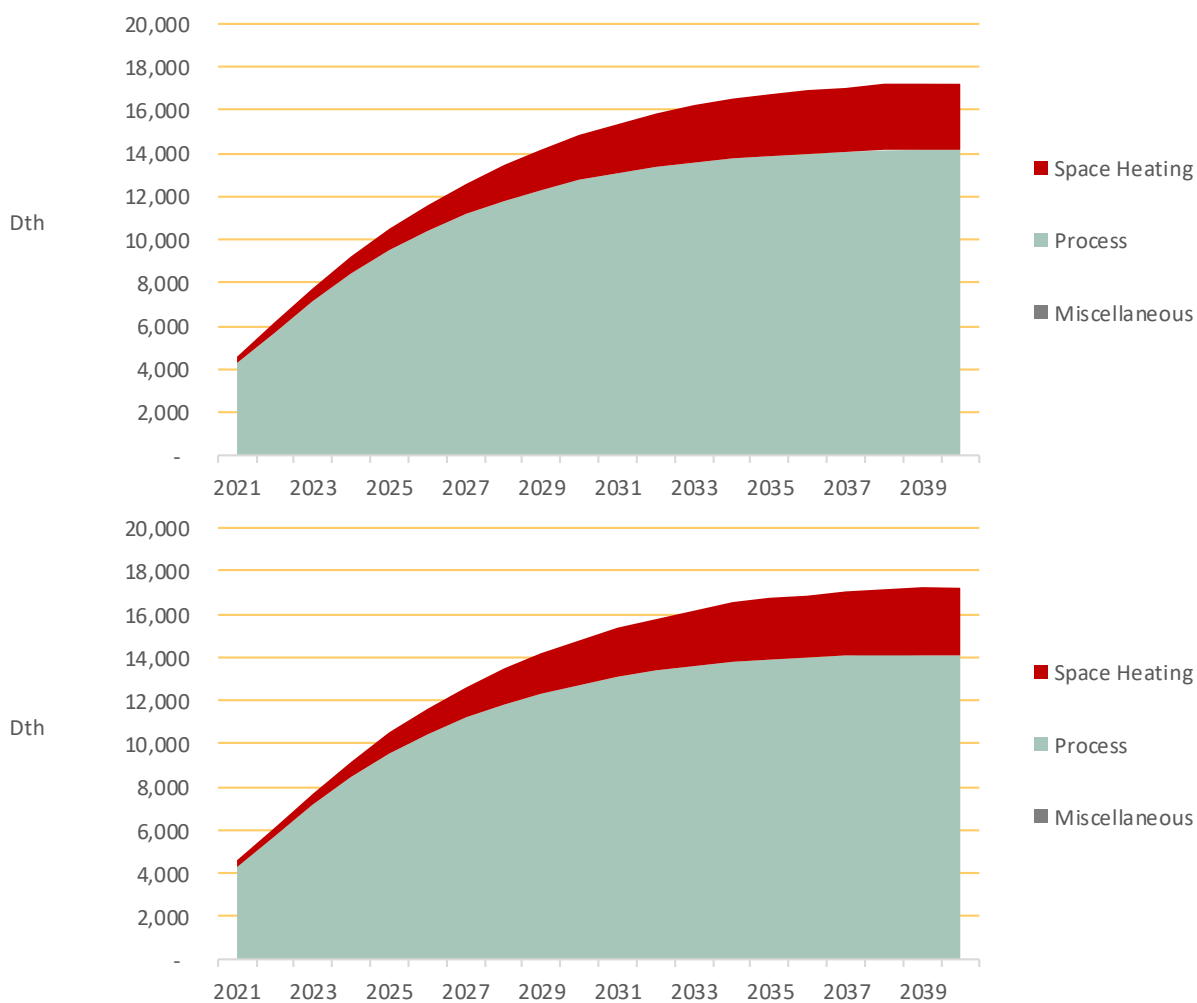

Table 6-12 identifies the top 20 industrial measures by cumulative 2021 and 2022 savings. Much like Washington, Process Heat Recovery is the largest measure by far, accounting for more than 70% of total industrial potential in Idaho.

Table 6-12 Industrial Top Measures in 2018 and 2019, UCT Achievable Economic Potential, Idaho (dekatherms)

Rank	Measure / Technology	2021 Cumulative Potential Savings (dekatherms)	% of Total	2022 Cumulative Potential Savings (dekatherms)	% of Total
1	Process Heat Recovery - HR system installed	1,158	72%	2,304	71%
2	Retrocommissioning - Optimized HVAC flow and controls	107	7%	210	6%
3	Retrocommissioning - Optimized process design and controls	107	7%	210	6%
4	Gas Boiler - High Turndown - Turndown control installed	77	5%	152	5%
5	Gas Boiler - Hot Water Reset - Reset control installed	76	5%	167	5%
6	Destratification Fans (HVLS) - Fans installed	27	2%	54	2%
7	Gas Boiler - Insulate Steam Lines/Condensate Tank - Lines and condensate tank insulated	19	1%	38	1%
8	Gas Boiler - Insulate Hot Water Lines - Insulated water lines	13	1%	25	1%
9	ENERGY STAR Connected Thermostat - Wi-Fi/interactive thermostat installed	12	1%	23	1%
10	Space Heating - Heat Recovery Ventilator - HRV installed	10	1%	21	1%
11	Boiler - AFUE 97%	3	0%	10	0%
12	Insulation - Wall Cavity - R-21	3	0%	7	0%
13	Furnace - AFUE 96%	2	0%	7	0%
14	Building Automation System - Automation system installed and programmed	2	0%	5	0%
15	Gas Furnace - Maintenance - General cleaning and maintenance	2	0%	3	0%
16	Thermostat - Programmable - Programmable thermostat installed	1	0%	3	0%
17	Steam Trap Maintenance - Cleaning and maintenance	1	0%	1	0%
18	Unit Heater - Infrared Radiant	0	0%	1	0%
Subtotal		1,619	100%	3,240	100%
Total Savings in Year		1,619	100%	3,240	100%

Incorporating the Total Resource Cost Test

In addition to the UCT, LoadMAP has been configured to evaluate potential using the TRC. This test focuses on impacts for both the utility and customer, which is an alternative frame of reference from the UCT. The TRC includes the full measure cost (incremental for lost opportunities, full cost for retrofits), which is generally substantially higher than the incentive cost included within the UCT. The TRC does include one additional value stream that the UCT does not, non-energy impacts. This test is fully incorporated into LoadMAP and prepared for Avista to use in the event the Company feels a “fully balanced” TRC is identified.

In accordance with Council methodology, these impacts must be quantified and monetized, meaning impacts such as personal comfort, which are difficult to assign a value to, are not included. What this does include are additional savings including water reductions due to low-flow measures or reduced detergent requirements to wash clothes in a high-efficiency clothes washer. AEG has incorporated these impacts as they are available in source documentation, such as RTF UES workbooks.

Some impacts are already included within Avista’s avoided costs. These include the 10% conservation credit applied by the Council for infrastructure benefits of efficiency. The future prices of carbon are also included. Per TRC methodology, as these impacts are already captured within the avoided costs provided to AEG, we did not incorporate them a second time outside the costs.

Another set of impacts captured within Council methodology include the Simplified Energy Enthalpy Model (SEEM) “calibration credits”. The Council calibrates this energy model using metered end-use energy consumption to reflect actual conditions. While these are technically energy impacts, they are not captured as a benefit to a natural-gas utility as they are instead an impact on the customer. The Council then assumes the difference between the uncalibrated and calibrated models represents the impacts of secondary heating by different fuels present in the home. In the Council’s case, these could be small gas heaters or wood stoves present alongside an electric forced-air furnace. For Avista, AEG followed a similar methodology, but instead applied the calibration percent impact to estimated gas-heating savings rather than electric. To monetize these impacts, we incorporated the latest Mid C energy prices, including carbon impacts, from the RTF’s website, adjusted for differences in efficiency between electric and natural gas heating equipment (e.g. converted therm savings from an AFUE 80% baseline to kWh savings from an EF 0.97 resistance heater baseline). We applied these impacts to many non-equipment measures with space heating impacts in all sectors as well as to residential space heating equipment, which was the primary use for the Council.

Finally, AEG identified additional non-gas end uses which may be impacted by gas efficiency measures. These include impacts from other end uses, such as cooling savings due to efficient shell measures or lighting savings due to a comprehensive retrocommissioning or strategic energy management program. Like the calibration credit above, these do not have a benefit to a natural-gas utility but do to the customer. It is worth a note of caution when incorporating these impacts. Certain comprehensive building measures, such as retrocommissioning and strategic energy management have very large electric impacts that may be greater than the original estimated gas impacts. LED lighting is a very popular technology within electric utility-programs and can have massive impacts. Commercial HVAC retrocommissioning (RCx) includes both cooling and ventilation electric impacts, which could outweigh the gas space heating impacts. To realize these cost-effective savings, Avista would need to offer a comprehensive RCx program affecting both electric and natural gas end uses.

7

COMPARISON WITH CURRENT PROGRAMS

One of the goals of this study is to inform targets for future programs. As such, AEG conducted an in-depth comparison of the CPA's 2021 UCT Achievable Economic Potential with Avista's 2019 accomplishments at the sector-level. This involved assigning each measure within the CPA to an existing Avista program.

Washington Comparison with 2019 Programs

Residential Sector

Table 7-1 summarizes Avista's 2019 residential accomplishments and the 2021 UCT Achievable Economic potential estimates from LoadMAP. The LoadMAP estimate of 32,164 dekatherms is lower than Avista's 2019 accomplishments at 49,161 dekatherms.

Table 7-1 Comparison of Avista's Washington Residential Programs with 2018 UCT Achievable Economic Potential (dekatherms)

Program Group	2019 Accomplishments (dekatherms)	LoadMAP 2021 UCT (dekatherms)
Furnace	31,172	21,548
Boiler	433	51
Water Heater	3,303	1,901
ENERGY STAR Homes	67	47
Smart Thermostat	3,822	4,435
Ceiling Insulation	3,762	3,611
Wall Insulation	447	333
Floor Insulation	342	0
Doors	93	0
Windows	5,556	0
Air Sealing	134	163
Duct Insulation	10	0
Duct Sealing	21	0
Showerheads	0	75
Miscellaneous	1	0
Program Total	49,161	32,164

The main reason that potential is lower is that the baseline assumed for forced-air furnaces is adjusted in the following ways.

- The 2015 Washington State Energy Code (WSEC) prescribes very efficient building shell requirements, which substantially reduces the consumption of a new home. Since every new home requires a lost opportunity purchasing decision when constructed, they make up a large portion of the potential. The lower unit energy savings in new homes due to lower heating requirements reduces the unit energy savings (UES) from this measure.
- Another reason is the incorporation of a market baseline, which assumes not everyone purchases the minimum federal standard in the absence of efficiency programs. This results in approximately 20% of customers purchasing an AFUE 90% and 5% purchasing an AFUE 92% in the baseline, which reduces the average unit energy consumption upon which savings for an AFUE 95% are based,

Additional descriptions for other measure differences are provided below:

- Potential for ENERGY STAR Homes has been reduced due to WSEC 2015. The efficient shell requirements lower space heating savings from the prior estimate, which was made before this code went into effect.
- The most recently updated savings and cost characterizations for water heater and windows are reducing their cost effectiveness in some or all segments.

Commercial and Industrial Sectors

Table 7-2 summarizes Avista's 2019 commercial and industrial accomplishments and the 2021 UCT Achievable Economic potential estimates from LoadMAP. The LoadMAP estimate of 22,537 dekatherms is much higher than Avista's 2019 accomplishments at 7,902 dekatherms.

Table 7-2 Comparison of Avista's Washington Nonresidential Accomplishments with 2021 UCT Achievable Economic Potential (dekatherms)

Program Group	2019 Accomplishments (dekatherms)	LoadMAP 2021 UCT (dekatherms)
HVAC	1,786	11,683
Weatherization	0	3,711
Food Preparation	3,547	1,044
Custom	2,569	6,099
Program Total	7,902	22,537

The following are key drivers in commercial potential:

- The HVAC category includes both efficient equipment (e.g. boilers) as well as custom HVAC measures.
- Fryer and convection oven potential is substantial due to the high gas consumption of restaurants and Avista's current success with this program. This measure was heavily accelerated in LoadMAP.

Idaho Comparison with 2019 Programs

Residential Sector

Table 7-3 summarizes Avista's 2019 residential accomplishments and the 2021 UCT Achievable Economic potential estimates from LoadMAP. The LoadMAP estimate of 17,117 dekatherms is lower than Avista's 2019 accomplishments at 23,667 dekatherms.

Table 7-3 Comparison of Avista's Idaho Residential Programs with 2021 UCT Achievable Economic Potential (dekatherms)

Program Group	2019 Accomplishments (dekatherms)	LoadMAP 2021 UCT (dekatherms)
Furnace	17,308	14,054
Boiler	247	0
Water Heater	1,735	1,053
ENERGY STAR Homes	40	32
Smart Thermostat	1,931	0
Ceiling Insulation	722	1,643
Wall Insulation	55	142
Floor Insulation	21	0
Doors	4	0
Windows	1,579	0
Air Sealing	21	79
Duct Insulation	1	0
Duct Sealing	2	0
Showerheads	-	114
Miscellaneous	-	0
Program Total	23,667	17,117

Cost effective measures in LoadMAP show similar potential to Avista's programs, however some measures, such as Smart Thermostats and HE Windows, are not showing as cost effective in 2021 forward in LoadMAP. This is offset somewhat by the fact that, in contrast to Washington, Idaho's energy code does not cannibalize a large portion of the HVAC-related savings, resulting in a much steadier range of potential.

Commercial and Industrial Sectors

Table 7-4 summarizes Avista's 2019 commercial and industrial accomplishments and the 2021 UCT Achievable Economic potential estimates from LoadMAP. The LoadMAP estimate of 14,023 dekatherms is substantially higher than Avista's 2017 accomplishments at 3,024 dekatherms.

Table 7-4 Comparison of Avista's Idaho Nonresidential Accomplishments with 2021 UCT Achievable Economic Potential (dekatherms)

Program Group	2019 Accomplishments (dekatherms)	LoadMAP 2021 UCT (dekatherms)
HVAC	1,337	7,068
Weatherization	0	2,241
Food Preparation	1,273	638
Custom	414	4,075
Program Total	3,024	14,023

Similar to Washington, many custom HVAC measures were included within the HVAC category to reflect actual accomplishments.

8

COMPARISON WITH PREVIOUS STUDY

Residential Comparison with 2018 CPA

Table 8-1 compares first-year residential potential between Avista's 2018 and 2020 Natural Gas CPAs conducted by AEG. For both states, first year savings are marginally lower (for program categories).

Table 8-1 Comparison of Avista's Residential UCT Achievable Economic Potential between the 2016 and 2018 CPAs (dekatherms)

Program Group	Washington		Idaho	
	2018	2020	2018	2020
Furnace	19,091	21,548	11,816	14,054
Boiler	619	51	307	0
Water Heater	4,257	1,901	2,014	1,053
ENERGY STAR Homes	294	47	146	32
Smart Thermostat	1,344	4,435	664	0
Ceiling Insulation	1,072	3,611	534	1,643
Wall Insulation	904	333	452	142
Floor Insulation	1,135	0	774	0
Doors	0	0	0	0
Windows	9,426	0	820	0
Air Sealing	0	163	0	79
Duct Insulation	367	0	181	0
Duct Sealing	0	0	0	0
Showerheads	575	75	286	114
Miscellaneous	893	0	362	0
CPA Total	39,979	32,164	18,354	17,117

The slight decrease in potential is due to a few factors:

- Baseline efficiency has been improving
- Some measures are no longer cost effective as a result of updates to characterization of costs and savings

Nonresidential Comparison with 2018 CPA

Table 8-2 compares first-year nonresidential potential between Avista's 2018 and 2020 Natural Gas CPAs conducted by AEG. In Washington, the potential is similar, while it is higher in Idaho.

Table 8-2 Comparison of Avista's Nonresidential UCT Achievable Economic Potential between the 2016 and 2018 CPAs (dekatherms)

Program Group	Washington		Idaho	
	2018	2018	2017	2018
HVAC	11,925	11,683	3,769	7,068
Weatherization	1,694	3,711	941	2,241
Food Preparation	2,761	1,044	1,045	638
Custom	4,082	6,099	2,033	4,075
CPA Total	21,300	22,537	7,986	14,023

|

|

APPENDIX 3.2: ENVIRONMENTAL EXTERNALITIES OVERVIEW (OREGON JURISDICTION ONLY)

The methodology for determining avoided costs from reduced incremental natural gas usage considers commodity and variable transportation costs only. These avoided cost streams do not include environmental externality costs related to the gathering, transmission, distribution or end-use of natural gas.

Per traditional economic theory and industry practice, an environmental externality factor is typically added to the avoided cost when there is an opportunity to displace traditional supply-side resources with an alternative resource with no adverse environmental impact.

REGULATORY GUIDANCE

The Oregon Public Utility Commission (OPUC) issued Order 93-965 (UM-424) to address how utilities should consider the impact of environmental externalities in planning for future energy resources. The Order required analysis on the potential natural gas cost impacts from emitting carbon dioxide (CO₂) and nitric-oxide (NO_x).

The OPUC's Order No. 07-002 in Docket UM 1056 (Investigation Into Integrated Resource Planning) established the following guideline for the treatment of environmental costs used by energy utilities that evaluate demand-side and supply-side energy choices:

UM 1056, Guideline 8 - Environmental Costs

“Utilities should include, in their base-case analyses, the regulatory compliance costs they expect for carbon dioxide (CO₂), nitrogen oxides (NO_x), sulfur oxides (SO₂), and mercury (Hg) emissions. Utilities should analyze the range of potential CO₂ regulatory costs in Order No. 93-695, from \$0 - \$40 (1990\$). In addition, utilities should perform sensitivity analysis on a range of reasonably possible cost adders for nitrogen oxides (NO_x), sulfur dioxide (SO₂), and mercury (Hg), if applicable.

In June 2008, the OPUC issued Order 08-338 (UM1302) which revised UM1056, Guideline 8. The revised guideline requires the utility should construct a base case portfolio to reflect what it considers to be the most likely regulatory compliance future for the various emissions. Additionally the guideline requires the utility to develop several compliance scenarios ranging from the present CO₂ regulatory level to the upper reaches of credible proposals and each scenario should include a time profile of CO₂ costs. The utility is also required to include a “trigger point” analysis in which the utility must determine at what level of carbon costs its selection of portfolio resources would be significantly different.

ANALYSIS

Unlike electric utilities, environmental cost issues rarely impact a natural gas utility's supply-side resource options. This is because the only supply-side energy resource is natural gas. The utility cannot choose between say "dirty" coal-fired generation and "clean" wind energy sources. The supply-side implication of environmental externalities generally relates to combustion of fuel to move or compress natural gas. Avista's direct gas distribution system infrastructure relies solely on the upstream line pressure of the interstate pipeline transportation network to distribute natural gas to its customers and thus does not directly combust fuels that result in any CO₂, NO_x, SO₂, or Hg emissions.

Upstream gas system infrastructure (pipelines, storage facilities, and gathering systems), however, do produce CO₂ emissions via compressors used to pressurize and move natural gas. Accessing CO₂ emissions data on these upstream activities to perform detailed meaningful analysis is challenging. In the 2009 Natural Gas IRP there was significant momentum regarding GHG legislation and the movement towards the creation of carbon cap and trade markets or tax structure. Additionally, the pricing level of the framework has been greatly reduced. Whichever structure ultimately gets implemented, Avista believes the cost pass through mechanisms for upstream gas system infrastructure will not make a difference in supply-side resource selection although the amount of cost pass through could differ widely.

Table 3.2.1 summarizes a range of environmental cost adders we believe capture several compliance futures including our expected scenario. The CO₂ cost adders reflect outlooks we obtained from one of our consultants, and following discussion and feedback from the TAC, have been incorporated into our Expected Case, Average Case, Low Growth & High Prices, Electrification - Carbon Reduction, and High Growth & Low Prices portfolios.

The guidelines also call for a trigger point analysis that reflects a “turning point” at which an alternate resource portfolio would be selected at different carbon cost adders levels. Because natural gas is the only supply resource applicable to LDC’s any alternate resource portfolio selection would be a result of delivery methods of natural gas to customers. Conceptually, there could be differing levels of cost adders applicable to pipeline transported supply versus in service territory LNG storage gas. From a practical standpoint however, the differences in these relative cost adders would be very minor and would not change supply-side resource selection regardless of various carbon cost adder levels. We do acknowledge there is influence to the avoided costs which would impact the cost effectiveness of demand-side measures in the DSM business planning process.

CONSERVATION COST ADVANTAGE

For this IRP, we also incorporated a 10 percent environmental externality factor into our assessment of the cost-effectiveness of existing demand-side management programs. Our assessment of prospective demand-side management opportunities is based on an avoided cost stream that includes this 10 percent factor.

Environmental externalities were evaluated in the IRP by adding the cost per therm equivalent of the externality cost values to supply-side resources as described in OPUC Order No. 93-965. Avista found that the environmental cost adders had no impact on the company’s supply-side choices, although they did impact the level of demand-side measures that could be cost-effective to acquire.

REGULATORY FILING

Avista will file revised cost-effectiveness limits (CELs) based upon the updated avoided costs available from this IRP process within the prescribed regulatory timetable.

TABLE 3.2.1: ENVIRONMENTAL EXTERNALITIES COST ADDER ANALYSIS (2020\$)

		2025	2030	2035	2040	
Expected Carbon Case	NOx – Annual	\$/short ton	\$ 2.00	\$ 2.00	\$ 2.00	\$ 2.00
		\$/lb	\$ 0.001	\$ 0.001	\$ 0.001	\$ 0.001
		lbs/therm	0.066	0.066	0.066	0.066
		NOx Adder \$/therm	\$ 0.00	\$ 0.00	\$ 0.00	\$ 0.00
	NOx – Seasonal	\$/short ton	\$ 290	\$ 290	\$ 290	\$ 290
		\$/lb	\$ 0.145	\$ 0.145	\$ 0.145	\$ 0.145
		lbs/therm	0.066	0.066	0.066	0.066
		NOx Adder \$/therm	\$ 0.01	\$ 0.01	\$ 0.01	\$ 0.01
	CO2	\$/Metric Ton	\$ 20.91	\$ 36.86	\$ 63.37	\$ 97.90
		\$/lb	\$ 0.009	\$ 0.017	\$ 0.029	\$ 0.044
		lbs/therm	12.827	12.827	12.827	12.827
		CO2 Adder \$/therm	\$ 0.12	\$ 0.21	\$ 0.37	\$ 0.57

		2025	2030	2035	2040	
High Carbon Case	NOx – Annual	\$/short ton	\$ 2.00	\$ 2.00	\$ 2.00	\$ 2.00
		\$/lb	\$ 0.001	\$ 0.001	\$ 0.001	\$ 0.001
		lbs/therm	0.066	0.066	0.066	0.066
		NOx Adder \$/therm	\$ 0.00	\$ 0.00	\$ 0.00	\$ 0.00
	NOx – Seasonal	\$/short ton	\$ 290	\$ 290	\$ 290	\$ 290
		\$/lb	\$ 0.145	\$ 0.145	\$ 0.145	\$ 0.145
		lbs/therm	0.066	0.066	0.066	0.066
		NOx Adder \$/therm	\$ 0.01	\$ 0.01	\$ 0.01	\$ 0.01
	CO2	\$/Metric Ton	\$ 187.44	\$ 229.15	\$ 281.11	\$ 339.87
		\$/lb	\$ 0.085	\$ 0.104	\$ 0.128	\$ 0.154
		lbs/therm	12.827	12.827	12.827	12.827
		CO2 Adder \$/therm	\$ 1.09	\$ 1.33	\$ 1.64	\$ 1.98

		2025	2030	2035	2040	
Low Carbon Low NOx	NOx – Annual	\$/short ton	\$ 2.00	\$ 2.00	\$ 2.00	\$ 2.00
		\$/lb	\$ 0.001	\$ 0.001	\$ 0.001	\$ 0.001
		lbs/therm	0.066	0.066	0.066	0.066
		NOx Adder \$/therm	\$ 0.00	\$ 0.00	\$ 0.00	\$ 0.00
	NOx – Seasonal	\$/short ton	\$ 290	\$ 290	\$ 290	\$ 290
		\$/lb	\$ 0.145	\$ 0.145	\$ 0.145	\$ 0.145
		lbs/therm	0.066	0.066	0.066	0.066
		NOx Adder \$/therm	\$ 0.01	\$ 0.01	\$ 0.01	\$ 0.01
	CO2	\$/Metric Ton	\$ -	\$ -	\$ -	\$ -
		\$/lb	\$ -	\$ -	\$ -	\$ -
		lbs/therm	12.827	12.827	12.827	12.827
		CO2 Adder \$/therm	\$ -	\$ -	\$ -	\$ -

APPENDIX 4.1: CURRENT TRANSPORTATION/STORAGE RATES AND ASSUMPTIONS

Current Tariff Rates (1)			
	Reservation	Commodity	Fuel Rate
TransCanada NGTL System Firm Rates (2)			
FT-D Demand Rate Alberta-B.C. Border	\$4.79CAD/GJ/month	N/A	N/A
TransCanada Foothills BC System Firm Rates (3)			
FT A/BC to Kingsgate	\$1.777CAD/GJ/month	N/A	2.10%
GTN FTS-1 Rates			
Mileage Based - Representative Example			
Kingsgate to Spokane	\$0.067812/Dth/day	\$0.001733/Dth/day	0.0046% per Dth/mile
Kingsgate to Malin	\$0.250322/Dth/day	\$0.009799/Dth/day	0.0046% per Dth/mile
Medford Lateral	\$0.222544/Dth/day	\$0.002291/Dth/day	N/A
Spectra Energy/Westcoast System Firm Rates (4)			
Postage Stamp Rates			
Station 2 to Huntingdon/Sumas	\$613.3CAD/103/m3/month	N/A	N/A
Williams NWP			
Postage Stamp Rates			
TF-1	\$0.39033/Dth/day	\$0.00832/Dth/day	0.88%
TF-2	\$0.39033/Dth/day	\$0.00832/Dth/day	0.88%
SGS-2F	\$0.01562/Dth/day	\$0.00057/Dth/day	0.88%
(1) Rates and Fuel reported are from current tariffed rates in the established currency and energy units of each pipeline			
(2) Rate does not reflect current term-differentiation or Abandonment Surcharge			
(3) Rate does not include Abandonment Surcharge			
(4) Rate changes annually			

APPENDIX 5: AVISTA RENEWABLE RESOURCE DEVELOPMENT AND PROCUREMENT DECISION TREE

APPENDIX 5.1: AVISTA RENEWABLE RESOURCE LEAST COST/LEAST RISK EVALUATION CRITERIA AND CALCULATIONS

Annual all-in cost of RNG (R) =
 Cost of methane (M) + Emissions compliance costs (E) – Avoided infrastructure costs (I)

$$\text{Or: } R_T = M_T + E_T - I_T$$

Where:

$$M_T = X_T + \sum_{t=1}^{365} [P_{T,t} + Y_{T,t}^{RNG}] Q_{T,t}$$

$$E_T = \sum_{t=1}^{365} N^{RNG} G_T Q_{T,t}$$

$$I_T = S_T A_T + D H_T$$

Substituting leaves the annual all-in cost of RNG as:

$$R_T = X_T - S_T A_T - D H_T + \sum_{t=1}^{365} [P_{T,t} + Y_{T,t}^{RNG} + N^{RNG} G_T] Q_{T,t}$$

Where the annual all-in cost of the conventional natural gas alternative (C) is:

$$C_T = \sum_{t=1}^{365} [V_{T,t} + Y_{T,t}^{CONV} + N^{CONV} G_T] Q_{T,t}$$

The present value of revenue requirement of all relevant years is used for evaluation where:

$$PVRR(R) = \sum_{T=k}^{T=k+z} \frac{R_T}{[1+d]^T}$$

$$PVRR(C) = \sum_{T=k}^{T=k+z} \frac{C_T}{[1+d]^T}$$

This is risk-adjusted to account for uncertainty in long-term forecasting where:

$$rPVRR(R) = 0.75 * \text{deterministic } PVRR(R) + 0.25 * 95\text{th Percentile Stochastic } PVRR(R)$$

$$rPVRR(C) = 0.75 * \text{deterministic } PVRR(C) + 0.25 * 95\text{th Percental Stochastic } PVRR(C)$$

The RNG project is a least cost/least risk resource to acquire if:

$$rPVRR(R) \leq rPVRR(C)$$

Term	Units	Description	Source	Project Specific?	Input or Output of Optimization?	Treated as Uncertain?
R	\$/Year	Annual all-in cost of prospective renewable resource project	Output of renewable resource evaluation process	Yes	Output	Yes
C	\$/Year	Annual all-in cost of conventional natural gas alternative	Output of renewable resource evaluation process	Yes	Output	Yes
M	\$/Year	Annual costs of natural gas and the associated facilities and operations to access it	Output of renewable resource evaluation process	Yes	Output	Yes
E	\$/Year	Annual greenhouse gas emissions compliance costs	Output of renewable resource evaluation process	Yes	Output	Yes
I	\$/Year	Annual infrastructure costs avoided with on-system supply	Output of renewable resource evaluation process	Yes	Output	Yes
Q	Dth	Expected or contracted daily quantity of renewable resource supplied by project	Project evaluation or renewable resource supplier counterparty	Yes	Input	If no contractual obligation
P	\$/Dth	Contracted or expected volumetric price of renewable resource	Project evaluation or renewable resource counterparty; Max cost-effective price determined by methodology if Avista initiating negotiations	Yes	Input if responding to offer; Output if Avista making offer	If no contractual obligation
T	Year	Year relative to current year, where the current year T = 0, next year T = 1, etc.	Project evaluation or renewable resource supplier counterparty	Yes	Input if responding to offer; Output if Avista making offer	If no contractual obligation
k	Year	When the RNG purchase starts in # of years in the future; k = renewable resource start year - current year	Project evaluation or renewable resource supplier counterparty	Yes	Input if responding to offer; Output if Avista making offer	If no contractual obligation
z	Years	Duration of renewable resource purchase or development in years	Project evaluation or renewable resource supplier counterparty	Yes	Input if responding to offer; Output if Avista making offer	If no contractual obligation
t	Days	Day number in year T from 1 to 365	N/A	No	Input	No
V	\$/Dth	Price of conventional gas that would be displaced by renewable resource project	Average price of last Q quantity of conventional gas dispatched without renewable resource project	Yes	Output	Yes
Y	\$/Dth	Variable transport costs to deliver gas to Avista's system	For off-system renewable resource - based upon geographic location of project; For conventional gas - determined from the marginal unit of gas dispatched to meet demand	Yes	Output	No
X	\$/Year	Annual revenue requirement of capital costs to access resource	Engineering project evaluation or renewable resource supplier counterparty	Yes	Input	If no contractual obligation
N	TonsCO ₂ e/Dth	Greenhouse gas intensity of natural gas being considered	Based on expected policy treatment of carbon intensity for reported emissions from renewable resource	Yes	Input	No
G	\$/TonCO ₂ e	Volumetric Greenhouse gas emissions compliance costs/price	Expected greenhouse gas compliance costs from the most recent update	No	Input	Yes
S	\$/Dth	System gas supply capacity cost to serve one dekatherm of peak day load	Based upon marginal supply capacity resource that is being deferred using Base Case resource availability from the most recent update	No	Output	Yes
A	Dth	Minimum natural gas injected on to Avista's system during a peak day by project	Project evaluation or contractual obligation from renewable resource supplier counterparty	Yes	Input	If no contractual obligation
D	\$/Dth	Distribution system capacity cost to serve one dekatherm of peak hour load	Distribution system cost to serve peak hour load from avoided costs in most recent update	No	Input	No
H	Dth	Minimum natural gas injected on to Avista's system during a peak hour by project	Project evaluation or contractual obligation from renewable resource supplier counterparty	Yes	Input	If no contractual obligation
d	% rate	Discount rate	Discount rate from most recent update	No	Input	No

APPENDIX 5.2: AVISTA RENEWABLE RESOURCE PROJECT REVENUE REQUIREMENT MODEL

Term	Line Item	Calculation					
		1	2	3	4	5	...
T	Project Year						
A	Tax Basis of Project Investment	$TCapEx_T$					
B	Book Basis of Project Investment	$BCapEx_T$					
C	Book Depreciation on Tax Basis	$TDr_T * \sum B_{T=1 \text{ to current } T}$					
D	Book Depreciation on Book Basis	$BDr_T * \sum B_{T=1 \text{ to current } T}$					
E	Accumulated Book Depreciation	$\sum D_{T=1 \text{ to current } T}$					
F	Beginning Net Book Value	$F_{T-1} + B_T - D_{T-1}$					
G	Property Tax Expense	$F_T * PTR$					
H	Tax Depreciation	$TDr_T * \sum A_{T=1 \text{ to current } T}$					
I	Deferred Taxes	$(H_T - C_T) * FITr$					
J	Beginning Rate Base	$B_T + K_{T-1}$					
K	Ending Rate Base	$J_T - I_T - D_T$					
L	Average Rate Base	$(J_T + K_T)/2$					
M	Interest Expense	$DF * DFr * L_T$					
N	Shareholders' Equity Return	$EF * EFr * L_T$					
O	Feedstock, O&M, and A&G Expense	$RRF_T + O\&M_T + A\&G_T$					
R	Duplicate Revenue Requirement	$[D_T + M_T + N_T + O_T + G_T - (SITr + (1 - SITr) * FITr) * (C_T + M_T + O_T + G_T)] / CF$					
S	Miscellaneous Revenue Items	$R_T * MR$					
U	State Income Tax Expense	$(R_T - C_T - M_T - O_T - G_T - S_T) * SITr$					
V	Federal Income Tax Expense	$(R_T - C_T - M_T - O_T - G_T - S_T - U_T) * FITr$					
W	Revenue Requirement	$D_T + M_T + N_T + O_T + G_T + S_T + U_T + V_T$					
Q	Renewable Resource Quantity	Q_T					
P	Price of Renewable Resource	W_T / Q_T					

Term	Units	Description	Project Specific?	Input or Output	Treated as Uncertain?
A	\$	Taxable basis of capital investment(s) in project asset(s) up to and including current project year	Yes	Input	Yes
B	\$	Book basis of capital investment(s) in project asset(s) up to and including current project year	Yes	Input	Yes
C	\$	Book depreciation of project assets on tax basis in project year	Yes	Output	Yes
D	\$	Book depreciation of project assets on book basis in project year	Yes	Output	Yes
E	\$	Accumulated book depreciation of project assets up to and including current project year	Yes	Output	Yes
F	\$	Net book value of project assets at beginning of project year	Yes	Output	Yes
G	\$	Property taxes paid in year of project	Yes	Output	Yes
H	\$	Tax depreciation in year of project	Yes	Output	Yes
I	\$	Deferred taxes in year of project	Yes	Output	Yes
J	\$	Rate base at beginning of project year	Yes	Output	Yes
K	\$	Rate base at end of project year	Yes	Output	Yes
L	\$	Average rate base in year of project	Yes	Output	Yes
M	\$	Interest paid in project year on project investment(s) financed with debt	Yes	Output	Yes
N	\$	Shareholder return on equity in year of project	Yes	Output	Yes
O	\$	Renewable resource feedstock, operating & maintenance, and administrative & general expenses in year of project	Yes	Output	Yes
P	\$	Average revenue requirement per unit of renewable resource developed in year of project	Yes	Output	Yes
Q	\$	Units of renewable resource created in year of project	Yes	Input	If no contractual obligation
R	\$	Revenue Requirement in year of project; duplicated for purpose of calculating miscellaneous revenues and state and federal income tax expenses	Yes	Output	Yes
S	\$	Miscellaneous revenues for items such as uncollectables, commission fees, excise taxes, and franchise fees	Yes	Output	Yes
T	\$	Year of project, where first year T = 1, next year T = 2, etc.	Yes	Input	If no contractual obligation
U	\$	State income taxes paid in year of project	Yes	Output	Yes
V	\$	Federal income taxes paid in year of project	Yes	Output	Yes
W	\$	Revenue requirement in year of project	Yes	Output	Yes
A&G	\$	Administrative and general expense in year of project	Yes	Input	Yes
BCapEx	\$	Book basis of project asset(s) in year of investment	Yes	Input	Yes
BDr	%	Project asset book depreciation rate in year relative to capital investment	No	Input	No
CF	%	Revenue conversion factor after accounting for miscellaneous revenue items and state and federal income taxes	No	Input	No
DF	%	Percentage of capital investment(s) in project asset(s) financed with debt	Yes	Input	No
Dfr	%	Rate of return on debt financing	No	Input	No
EF	%	Percentage of capital investment(s) in project asset(s) financed with equity	Yes	Input	No
Efr	%	Shareholder rate of return on equity	No	Input	No
FITr	%	Federal income tax rate	No	Input	No
MR	%	Percentage of revenues allocated to items such as uncollectables, commission fees, excise taxes, and franchise fees.	No	Input	No
O&M	\$	Operating and maintenance expense in year of project	Yes	Input	Yes
PTr	%	Property tax rate	Yes	Input	No
RRF	\$	Feedstock expense of renewable resource in year of project	Yes	Input	If no contractual obligation
SITr	%	State income tax rate	No	Input	No
TCapEx	\$	Tax basis of project asset(s) in year of investment	Yes	Input	Yes
TDr	%	Project asset tax depreciation rate in year relative to year of capital investment	No	Input	No

APPENDIX 5.3: AVISTA RENEWABLE RESOURCE PROJECT RATE IMPACT ANALYSIS

Avista will analyze all RNG-related investment costs and determine the appropriate rate recovery mechanism, which may include an impact on base rates, purchase gas adjustments or other cost recovery tariffs. This analysis considers, but is not limited to, factors such as the jurisdictions involved, expenditure types, cost recovery mechanisms, the spread of the investment to Avista's customer base and other potential impacts to ensure the appropriate treatment of the investment.

APPENDIX 5.4: AVISTA RENEWABLE RESOURCE PROJECT CARBON REDUCTION CALCULATION

$$G_T^{CONV} = Q_T * N^{CONV}$$

$$G_T^{RNG} = Q_T * N^{RNG}$$

Total annual greenhouse gas emissions without renewable resource:

$$E_T^{CONV} = A_T * N^{CONV}$$

Total annual greenhouse gas emissions with renewable resource:

$$E_T^{CONV, RNG} = E_T^{CONV} - (G_T^{CONV} - G_T^{RNG})$$

Term	Units	Description	Project Specific?	Input or Output	Treated as Uncertain?
N	TonsCO ₂ e/Dth	Greenhouse gas intensity of resource being considered	Yes	Input	No
G	TonsCO ₂ e	Greenhouse gas emissions of resource being considered	Yes	Output	Yes
Q	Dth	Expected or contracted quantity of renewable resource	Yes	Input	If no contractual obligation
E	TonsCO ₂ e	Avista greenhouse gas emissions	No	Output	No
A	Dth	Dekatherms delivered to Avista customers	No	Input	No
T	Year	Year relative to current year, where the current year T = 1, next year T =2, etc.	Yes	Input if responding to offer, Output if Avista making offer	If no contractual obligation

APPENDIX 6.1: MONTHLY PRICE DATA BY BASIN

EXPECTED PRICE

Scenario	Index	Gas Year	Nominal \$											
			Nov	Dec	Jan	Feb	Mar	Apr	May	Jun	Jul	Aug	Sep	Oct
Expected Prices	AECO	2019-2020	\$2.13	\$1.84	\$1.77	\$1.41	\$1.23	\$1.01	\$1.12	\$0.88	\$0.85	\$1.08	\$0.97	\$1.00
Expected Prices	AECO	2020-2021	\$1.77	\$2.32	\$2.40	\$2.29	\$1.98	\$1.47	\$1.37	\$1.42	\$1.55	\$1.54	\$1.39	\$1.42
Expected Prices	AECO	2021-2022	\$1.76	\$2.04	\$2.15	\$2.01	\$1.70	\$1.08	\$1.06	\$1.16	\$1.31	\$1.26	\$1.08	\$1.08
Expected Prices	AECO	2022-2023	\$1.35	\$1.85	\$1.96	\$1.76	\$1.50	\$1.04	\$1.01	\$1.18	\$1.23	\$1.24	\$0.97	\$1.05
Expected Prices	AECO	2023-2024	\$1.56	\$1.81	\$2.02	\$1.72	\$1.65	\$1.35	\$1.34	\$1.35	\$1.33	\$1.33	\$1.41	\$1.42
Expected Prices	AECO	2024-2025	\$1.56	\$1.80	\$2.07	\$1.95	\$1.83	\$1.65	\$1.73	\$1.66	\$1.66	\$1.66	\$1.75	\$1.75
Expected Prices	AECO	2025-2026	\$1.97	\$2.13	\$2.45	\$2.39	\$2.25	\$2.06	\$2.08	\$2.06	\$2.05	\$2.06	\$2.10	\$2.16
Expected Prices	AECO	2026-2027	\$2.39	\$2.51	\$2.64	\$2.53	\$2.39	\$2.20	\$2.26	\$2.21	\$2.20	\$2.22	\$2.27	\$2.26
Expected Prices	AECO	2027-2028	\$2.57	\$2.73	\$2.79	\$2.69	\$2.57	\$2.28	\$2.38	\$2.36	\$2.36	\$2.38	\$2.43	\$2.52
Expected Prices	AECO	2028-2029	\$2.79	\$2.84	\$2.96	\$2.82	\$2.67	\$2.47	\$2.53	\$2.52	\$2.50	\$2.51	\$2.56	\$2.60
Expected Prices	AECO	2029-2030	\$2.90	\$3.03	\$3.06	\$2.94	\$2.81	\$2.58	\$2.61	\$2.58	\$2.53	\$2.56	\$2.62	\$2.75
Expected Prices	AECO	2030-2031	\$3.04	\$3.18	\$3.19	\$3.09	\$2.93	\$2.72	\$2.74	\$2.71	\$2.67	\$2.67	\$2.77	\$2.82
Expected Prices	AECO	2031-2032	\$3.17	\$3.27	\$3.28	\$3.16	\$3.00	\$2.83	\$2.82	\$2.77	\$2.60	\$2.62	\$2.81	\$2.93
Expected Prices	AECO	2032-2033	\$3.32	\$3.42	\$3.50	\$3.44	\$3.29	\$3.10	\$3.08	\$3.08	\$2.96	\$2.98	\$3.11	\$3.19
Expected Prices	AECO	2033-2034	\$3.60	\$3.66	\$3.71	\$3.59	\$3.45	\$3.25	\$3.25	\$3.22	\$3.16	\$3.18	\$3.28	\$3.39
Expected Prices	AECO	2034-2035	\$3.74	\$3.85	\$3.86	\$3.72	\$3.52	\$3.37	\$3.37	\$3.32	\$3.18	\$3.23	\$3.36	\$3.44
Expected Prices	AECO	2035-2036	\$3.84	\$4.01	\$4.04	\$3.97	\$3.78	\$3.55	\$3.55	\$3.53	\$3.32	\$3.35	\$3.50	\$3.65
Expected Prices	AECO	2036-2037	\$4.06	\$4.19	\$4.24	\$4.02	\$3.86	\$3.59	\$3.72	\$3.70	\$3.57	\$3.67	\$3.76	\$3.90
Expected Prices	AECO	2037-2038	\$4.35	\$4.51	\$4.54	\$4.26	\$4.00	\$3.79	\$3.83	\$3.83	\$3.67	\$3.70	\$3.80	\$3.92
Expected Prices	AECO	2038-2039	\$4.37	\$4.57	\$4.64	\$4.42	\$4.28	\$4.04	\$4.08	\$3.99	\$3.86	\$3.86	\$4.04	\$4.15
Expected Prices	AECO	2039-2040	\$4.64	\$4.80	\$4.82	\$4.59	\$4.42	\$4.20	\$4.23	\$4.20	\$4.09	\$4.13	\$4.26	\$4.37

Scenario	Index	Gas Year	Nominal \$											
			Nov	Dec	Jan	Feb	Mar	Apr	May	Jun	Jul	Aug	Sep	Oct
Expected Prices	Malin	2019-2020	\$2.85	\$2.95	\$2.20	\$1.80	\$1.43	\$1.24	\$1.14	\$0.95	\$0.95	\$1.31	\$1.28	\$1.38
Expected Prices	Malin	2020-2021	\$1.86	\$2.58	\$2.69	\$2.62	\$2.35	\$1.92	\$1.88	\$1.87	\$2.04	\$2.08	\$2.15	\$2.16
Expected Prices	Malin	2021-2022	\$2.39	\$2.55	\$2.62	\$2.56	\$2.38	\$1.78	\$1.73	\$1.75	\$1.83	\$1.85	\$1.85	\$1.86
Expected Prices	Malin	2022-2023	\$2.16	\$2.37	\$2.50	\$2.44	\$2.30	\$1.77	\$1.64	\$1.67	\$1.72	\$1.75	\$1.84	\$1.85
Expected Prices	Malin	2023-2024	\$2.01	\$2.21	\$2.36	\$2.21	\$2.08	\$1.74	\$1.71	\$1.73	\$1.78	\$1.82	\$2.09	\$2.14
Expected Prices	Malin	2024-2025	\$2.23	\$2.37	\$2.57	\$2.52	\$2.41	\$2.24	\$2.22	\$2.17	\$2.20	\$2.25	\$2.45	\$2.46
Expected Prices	Malin	2025-2026	\$2.63	\$2.76	\$3.06	\$2.98	\$2.84	\$2.61	\$2.53	\$2.49	\$2.55	\$2.66	\$2.88	\$2.89
Expected Prices	Malin	2026-2027	\$3.06	\$3.18	\$3.23	\$3.13	\$2.98	\$2.86	\$2.79	\$2.72	\$2.79	\$2.92	\$3.11	\$3.11
Expected Prices	Malin	2027-2028	\$3.35	\$3.50	\$3.53	\$3.29	\$3.20	\$2.93	\$2.90	\$2.93	\$2.98	\$3.14	\$3.32	\$3.36
Expected Prices	Malin	2028-2029	\$3.58	\$3.74	\$3.76	\$3.49	\$3.33	\$3.13	\$3.08	\$3.06	\$3.15	\$3.29	\$3.47	\$3.48
Expected Prices	Malin	2029-2030	\$3.73	\$4.00	\$3.99	\$3.73	\$3.51	\$3.28	\$3.21	\$3.26	\$3.25	\$3.46	\$3.58	\$3.65
Expected Prices	Malin	2030-2031	\$3.92	\$4.15	\$4.12	\$3.88	\$3.66	\$3.48	\$3.34	\$3.34	\$3.44	\$3.62	\$3.82	\$3.84
Expected Prices	Malin	2031-2032	\$4.14	\$4.35	\$4.33	\$3.99	\$3.81	\$3.61	\$3.49	\$3.55	\$3.44	\$3.64	\$3.95	\$4.01
Expected Prices	Malin	2032-2033	\$4.34	\$4.52	\$4.56	\$4.29	\$4.02	\$3.93	\$3.68	\$3.67	\$3.71	\$3.97	\$4.28	\$4.31
Expected Prices	Malin	2033-2034	\$4.65	\$4.79	\$4.80	\$4.50	\$4.20	\$4.09	\$3.91	\$3.98	\$3.96	\$4.19	\$4.47	\$4.52
Expected Prices	Malin	2034-2035	\$4.83	\$5.00	\$4.96	\$4.66	\$4.34	\$4.17	\$4.03	\$4.10	\$4.02	\$4.29	\$4.56	\$4.65
Expected Prices	Malin	2035-2036	\$4.99	\$5.20	\$5.15	\$4.82	\$4.56	\$4.35	\$4.15	\$4.23	\$4.06	\$4.44	\$4.74	\$4.81
Expected Prices	Malin	2036-2037	\$5.17	\$5.42	\$5.44	\$5.15	\$4.80	\$4.52	\$4.36	\$4.40	\$4.24	\$4.65	\$4.91	\$5.01
Expected Prices	Malin	2037-2038	\$5.40	\$5.63	\$5.60	\$5.28	\$4.98	\$4.62	\$4.52	\$4.59	\$4.43	\$4.85	\$5.13	\$5.19
Expected Prices	Malin	2038-2039	\$5.53	\$5.73	\$5.76	\$5.44	\$5.26	\$4.85	\$4.75	\$4.79	\$4.64	\$5.05	\$5.28	\$5.40
Expected Prices	Malin	2039-2040	\$5.79	\$6.04	\$5.95	\$5.57	\$5.30	\$5.02	\$4.93	\$4.85	\$4.90	\$5.21	\$5.49	\$5.59

Nominal \$														
Scenario	Index	Gas Year	Nov	Dec	Jan	Feb	Mar	Apr	May	Jun	Jul	Aug	Sep	Oct
Expected Prices	Rockies	2019-2020	\$2.81	\$2.93	\$2.18	\$1.76	\$1.36	\$1.12	\$1.02	\$0.87	\$0.86	\$1.22	\$1.19	\$1.29
Expected Prices	Rockies	2020-2021	\$1.79	\$2.44	\$2.58	\$2.50	\$2.28	\$1.84	\$1.80	\$1.79	\$1.96	\$2.01	\$2.08	\$2.08
Expected Prices	Rockies	2021-2022	\$2.31	\$2.48	\$2.55	\$2.49	\$2.30	\$1.70	\$1.65	\$1.67	\$1.75	\$1.78	\$1.78	\$1.79
Expected Prices	Rockies	2022-2023	\$2.08	\$2.31	\$2.38	\$2.28	\$2.05	\$1.64	\$1.60	\$1.63	\$1.68	\$1.70	\$1.79	\$1.81
Expected Prices	Rockies	2023-2024	\$2.01	\$2.24	\$2.43	\$2.29	\$2.12	\$1.69	\$1.67	\$1.69	\$1.74	\$1.78	\$2.04	\$2.10
Expected Prices	Rockies	2024-2025	\$2.29	\$2.47	\$2.73	\$2.65	\$2.47	\$2.19	\$2.20	\$2.20	\$2.28	\$2.29	\$2.41	\$2.41
Expected Prices	Rockies	2025-2026	\$2.66	\$2.81	\$3.15	\$3.11	\$2.91	\$2.57	\$2.53	\$2.53	\$2.69	\$2.71	\$2.83	\$2.85
Expected Prices	Rockies	2026-2027	\$3.09	\$3.24	\$3.33	\$3.26	\$3.05	\$2.86	\$2.87	\$2.87	\$2.96	\$2.99	\$3.06	\$3.07
Expected Prices	Rockies	2027-2028	\$3.35	\$3.56	\$3.63	\$3.44	\$3.32	\$2.97	\$2.97	\$2.95	\$3.17	\$3.18	\$3.27	\$3.32
Expected Prices	Rockies	2028-2029	\$3.55	\$3.80	\$3.86	\$3.62	\$3.45	\$3.14	\$3.13	\$3.15	\$3.34	\$3.34	\$3.42	\$3.43
Expected Prices	Rockies	2029-2030	\$3.70	\$4.01	\$4.02	\$3.82	\$3.60	\$3.26	\$3.25	\$3.26	\$3.42	\$3.47	\$3.53	\$3.60
Expected Prices	Rockies	2030-2031	\$3.87	\$4.13	\$4.13	\$3.98	\$3.77	\$3.45	\$3.42	\$3.44	\$3.63	\$3.64	\$3.78	\$3.80
Expected Prices	Rockies	2031-2032	\$4.10	\$4.30	\$4.34	\$4.14	\$3.94	\$3.61	\$3.56	\$3.58	\$3.62	\$3.68	\$3.91	\$3.97
Expected Prices	Rockies	2032-2033	\$4.32	\$4.48	\$4.56	\$4.42	\$4.18	\$3.89	\$3.81	\$3.85	\$3.94	\$4.01	\$4.23	\$4.26
Expected Prices	Rockies	2033-2034	\$4.63	\$4.76	\$4.83	\$4.66	\$4.39	\$4.07	\$4.02	\$4.03	\$4.14	\$4.23	\$4.43	\$4.48
Expected Prices	Rockies	2034-2035	\$4.83	\$4.98	\$5.00	\$4.84	\$4.55	\$4.20	\$4.17	\$4.19	\$4.23	\$4.37	\$4.51	\$4.60
Expected Prices	Rockies	2035-2036	\$4.99	\$5.16	\$5.18	\$5.01	\$4.75	\$4.41	\$4.34	\$4.38	\$4.44	\$4.53	\$4.70	\$4.77
Expected Prices	Rockies	2036-2037	\$5.18	\$5.43	\$5.48	\$5.32	\$5.00	\$4.59	\$4.58	\$4.57	\$4.68	\$4.75	\$4.86	\$4.96
Expected Prices	Rockies	2037-2038	\$5.42	\$5.67	\$5.70	\$5.46	\$5.12	\$4.75	\$4.75	\$4.77	\$4.91	\$4.97	\$5.11	\$5.17
Expected Prices	Rockies	2038-2039	\$5.55	\$5.81	\$5.88	\$5.63	\$5.39	\$4.99	\$4.97	\$4.98	\$5.16	\$5.20	\$5.29	\$5.39
Expected Prices	Rockies	2039-2040	\$5.80	\$6.11	\$6.08	\$5.76	\$5.53	\$5.20	\$5.18	\$5.20	\$5.33	\$5.39	\$5.50	\$5.59
Nominal \$														
Scenario	Index	Gas Year	Nov	Dec	Jan	Feb	Mar	Apr	May	Jun	Jul	Aug	Sep	Oct
Expected Prices	Stanfield	2019-2020	\$2.85	\$2.93	\$2.19	\$1.74	\$1.32	\$1.13	\$1.05	\$0.85	\$0.79	\$1.14	\$1.14	\$1.23
Expected Prices	Stanfield	2020-2021	\$1.71	\$2.36	\$2.51	\$2.44	\$2.24	\$1.83	\$1.77	\$1.74	\$1.87	\$1.94	\$2.03	\$2.05
Expected Prices	Stanfield	2021-2022	\$2.20	\$2.37	\$2.46	\$2.40	\$2.20	\$1.66	\$1.59	\$1.59	\$1.67	\$1.70	\$1.71	\$1.72
Expected Prices	Stanfield	2022-2023	\$1.93	\$2.16	\$2.24	\$2.15	\$1.97	\$1.56	\$1.50	\$1.52	\$1.56	\$1.61	\$1.69	\$1.70
Expected Prices	Stanfield	2023-2024	\$1.88	\$2.10	\$2.27	\$2.11	\$1.99	\$1.63	\$1.59	\$1.60	\$1.66	\$1.70	\$1.93	\$1.99
Expected Prices	Stanfield	2024-2025	\$2.11	\$2.25	\$2.47	\$2.41	\$2.28	\$2.09	\$2.06	\$2.01	\$2.04	\$2.10	\$2.30	\$2.30
Expected Prices	Stanfield	2025-2026	\$2.49	\$2.64	\$2.94	\$2.88	\$2.72	\$2.46	\$2.36	\$2.34	\$2.39	\$2.50	\$2.72	\$2.74
Expected Prices	Stanfield	2026-2027	\$2.92	\$3.05	\$3.11	\$3.02	\$2.85	\$2.69	\$2.62	\$2.55	\$2.63	\$2.76	\$2.95	\$2.95
Expected Prices	Stanfield	2027-2028	\$3.20	\$3.37	\$3.41	\$3.19	\$3.08	\$2.76	\$2.73	\$2.76	\$2.81	\$2.98	\$3.16	\$3.20
Expected Prices	Stanfield	2028-2029	\$3.43	\$3.61	\$3.64	\$3.37	\$3.20	\$2.96	\$2.90	\$2.89	\$2.98	\$3.14	\$3.31	\$3.32
Expected Prices	Stanfield	2029-2030	\$3.57	\$3.86	\$3.87	\$3.61	\$3.38	\$3.11	\$3.03	\$3.09	\$3.08	\$3.31	\$3.43	\$3.50
Expected Prices	Stanfield	2030-2031	\$3.77	\$4.02	\$3.99	\$3.76	\$3.52	\$3.30	\$3.17	\$3.16	\$3.27	\$3.47	\$3.67	\$3.69
Expected Prices	Stanfield	2031-2032	\$3.99	\$4.22	\$4.20	\$3.86	\$3.67	\$3.43	\$3.32	\$3.38	\$3.26	\$3.49	\$3.80	\$3.86
Expected Prices	Stanfield	2032-2033	\$4.19	\$4.39	\$4.43	\$4.17	\$3.89	\$3.76	\$3.50	\$3.48	\$3.54	\$3.81	\$4.12	\$4.15
Expected Prices	Stanfield	2033-2034	\$4.50	\$4.66	\$4.68	\$4.38	\$4.07	\$3.91	\$3.73	\$3.81	\$3.79	\$4.03	\$4.31	\$4.37
Expected Prices	Stanfield	2034-2035	\$4.68	\$4.86	\$4.83	\$4.54	\$4.20	\$4.00	\$3.84	\$3.93	\$3.85	\$4.13	\$4.40	\$4.49
Expected Prices	Stanfield	2035-2036	\$4.83	\$5.06	\$5.02	\$4.69	\$4.43	\$4.18	\$3.97	\$4.05	\$3.89	\$4.27	\$4.58	\$4.65
Expected Prices	Stanfield	2036-2037	\$5.02	\$5.28	\$5.31	\$5.02	\$4.67	\$4.35	\$4.17	\$4.22	\$4.06	\$4.48	\$4.74	\$4.84
Expected Prices	Stanfield	2037-2038	\$5.24	\$5.49	\$5.47	\$5.15	\$4.84	\$4.44	\$4.33	\$4.40	\$4.25	\$4.68	\$4.96	\$5.02
Expected Prices	Stanfield	2038-2039	\$5.37	\$5.59	\$5.63	\$5.31	\$5.11	\$4.67	\$4.56	\$4.60	\$4.45	\$4.87	\$5.11	\$5.22
Expected Prices	Stanfield	2039-2040	\$5.63	\$5.90	\$5.81	\$5.43	\$5.16	\$4.84	\$4.73	\$4.65	\$4.72	\$5.03	\$5.32	\$5.42

Scenario	Index	Gas Year	Nominal \$											
			Nov	Dec	Jan	Feb	Mar	Apr	May	Jun	Jul	Aug	Sep	Oct
Expected Prices	Sumas	2019-2020	\$4.11	\$3.20	\$2.28	\$1.70	\$1.36	\$1.14	\$1.03	\$0.88	\$0.89	\$1.31	\$1.25	\$1.45
Expected Prices	Sumas	2020-2021	\$2.22	\$3.10	\$3.03	\$2.81	\$2.44	\$1.82	\$1.77	\$1.76	\$1.95	\$2.02	\$2.03	\$2.02
Expected Prices	Sumas	2021-2022	\$2.57	\$2.96	\$2.94	\$2.79	\$2.41	\$1.59	\$1.52	\$1.55	\$1.66	\$1.68	\$1.67	\$1.66
Expected Prices	Sumas	2022-2023	\$2.31	\$2.77	\$2.83	\$2.67	\$2.30	\$1.58	\$1.51	\$1.56	\$1.65	\$1.68	\$1.69	\$1.69
Expected Prices	Sumas	2023-2024	\$2.35	\$2.80	\$2.87	\$2.66	\$2.37	\$1.73	\$1.64	\$1.66	\$1.63	\$1.64	\$1.72	\$1.73
Expected Prices	Sumas	2024-2025	\$2.51	\$2.81	\$2.99	\$2.86	\$2.63	\$2.07	\$1.97	\$1.89	\$1.89	\$1.89	\$2.00	\$2.34
Expected Prices	Sumas	2025-2026	\$2.76	\$3.14	\$3.35	\$3.22	\$2.89	\$2.55	\$2.26	\$2.23	\$2.22	\$2.24	\$2.33	\$2.74
Expected Prices	Sumas	2026-2027	\$3.08	\$3.55	\$3.56	\$3.25	\$3.03	\$2.78	\$2.44	\$2.38	\$2.37	\$2.39	\$2.49	\$2.88
Expected Prices	Sumas	2027-2028	\$3.35	\$3.58	\$3.65	\$3.43	\$3.29	\$2.64	\$2.56	\$2.53	\$2.53	\$2.56	\$2.68	\$3.29
Expected Prices	Sumas	2028-2029	\$3.55	\$3.84	\$3.88	\$3.62	\$3.42	\$3.06	\$2.71	\$2.70	\$2.68	\$2.68	\$2.79	\$3.38
Expected Prices	Sumas	2029-2030	\$3.70	\$4.05	\$4.05	\$3.81	\$3.57	\$3.20	\$2.79	\$2.76	\$2.76	\$2.79	\$2.88	\$3.36
Expected Prices	Sumas	2030-2031	\$3.88	\$4.16	\$4.18	\$3.97	\$3.73	\$3.38	\$2.97	\$2.94	\$2.90	\$2.90	\$3.05	\$3.45
Expected Prices	Sumas	2031-2032	\$4.11	\$4.36	\$4.38	\$4.12	\$3.91	\$3.51	\$3.05	\$3.01	\$2.83	\$2.86	\$3.10	\$3.58
Expected Prices	Sumas	2032-2033	\$4.33	\$4.53	\$4.61	\$4.41	\$4.17	\$3.75	\$3.32	\$3.32	\$3.19	\$3.22	\$3.39	\$3.82
Expected Prices	Sumas	2033-2034	\$4.64	\$4.82	\$4.87	\$4.66	\$4.38	\$3.90	\$3.49	\$3.46	\$3.40	\$3.42	\$3.57	\$4.06
Expected Prices	Sumas	2034-2035	\$4.84	\$5.03	\$5.05	\$4.84	\$4.52	\$4.02	\$3.62	\$3.56	\$3.43	\$3.47	\$3.64	\$4.12
Expected Prices	Sumas	2035-2036	\$4.99	\$5.20	\$5.23	\$5.01	\$4.74	\$4.09	\$3.79	\$3.77	\$3.56	\$3.59	\$3.77	\$4.22
Expected Prices	Sumas	2036-2037	\$5.19	\$5.47	\$5.52	\$5.32	\$4.99	\$4.16	\$3.97	\$3.95	\$3.81	\$3.91	\$4.03	\$4.46
Expected Prices	Sumas	2037-2038	\$5.43	\$5.69	\$5.73	\$5.46	\$5.12	\$4.34	\$4.06	\$4.05	\$3.89	\$3.91	\$4.02	\$4.47
Expected Prices	Sumas	2038-2039	\$5.56	\$5.83	\$5.89	\$5.63	\$5.39	\$4.58	\$4.32	\$4.22	\$4.08	\$4.09	\$4.27	\$4.71
Expected Prices	Sumas	2039-2040	\$5.81	\$6.11	\$6.09	\$5.76	\$5.47	\$4.75	\$4.47	\$4.43	\$4.32	\$4.35	\$4.49	\$4.91

APPENDIX 6.1: MONTHLY PRICE DATA BY BASIN

HIGH GROWTH LOW PRICE

			Nominal \$											
Scenario	Index	Gas Year	Nov	Dec	Jan	Feb	Mar	Apr	May	Jun	Jul	Aug	Sep	Oct
Low Prices	AECO	2019-2020	\$2.13	\$1.84	\$1.77	\$1.41	\$1.23	\$1.01	\$1.12	\$0.88	\$0.85	\$1.08	\$0.97	\$1.00
Low Prices	AECO	2020-2021	\$1.77	\$2.32	\$1.76	\$1.65	\$1.35	\$0.89	\$0.79	\$0.83	\$0.94	\$0.94	\$0.79	\$0.81
Low Prices	AECO	2021-2022	\$1.14	\$1.37	\$1.45	\$1.31	\$1.04	\$0.51	\$0.49	\$0.58	\$0.72	\$0.67	\$0.50	\$0.49
Low Prices	AECO	2022-2023	\$0.75	\$1.19	\$1.25	\$1.05	\$0.82	\$0.41	\$0.39	\$0.55	\$0.59	\$0.59	\$0.32	\$0.40
Low Prices	AECO	2023-2024	\$0.88	\$1.08	\$1.22	\$0.94	\$0.89	\$0.61	\$0.59	\$0.60	\$0.56	\$0.56	\$0.65	\$0.66
Low Prices	AECO	2024-2025	\$0.77	\$0.97	\$1.14	\$1.04	\$0.92	\$0.77	\$0.86	\$0.78	\$0.77	\$0.76	\$0.86	\$0.86
Low Prices	AECO	2025-2026	\$1.04	\$1.18	\$1.35	\$1.30	\$1.18	\$1.01	\$1.03	\$1.01	\$0.97	\$0.99	\$1.04	\$1.09
Low Prices	AECO	2026-2027	\$1.29	\$1.36	\$1.48	\$1.38	\$1.24	\$1.09	\$1.15	\$1.10	\$1.06	\$1.07	\$1.13	\$1.12
Low Prices	AECO	2027-2028	\$1.38	\$1.49	\$1.54	\$1.44	\$1.32	\$1.09	\$1.18	\$1.16	\$1.13	\$1.15	\$1.21	\$1.27
Low Prices	AECO	2028-2029	\$1.51	\$1.53	\$1.63	\$1.50	\$1.37	\$1.20	\$1.25	\$1.23	\$1.19	\$1.18	\$1.25	\$1.30
Low Prices	AECO	2029-2030	\$1.57	\$1.63	\$1.66	\$1.55	\$1.43	\$1.26	\$1.29	\$1.26	\$1.17	\$1.18	\$1.24	\$1.34
Low Prices	AECO	2030-2031	\$1.61	\$1.69	\$1.69	\$1.60	\$1.46	\$1.32	\$1.32	\$1.28	\$1.21	\$1.20	\$1.31	\$1.37
Low Prices	AECO	2031-2032	\$1.67	\$1.69	\$1.70	\$1.60	\$1.48	\$1.36	\$1.34	\$1.28	\$1.06	\$1.06	\$1.26	\$1.36
Low Prices	AECO	2032-2033	\$1.68	\$1.75	\$1.80	\$1.77	\$1.65	\$1.52	\$1.49	\$1.49	\$1.32	\$1.33	\$1.47	\$1.55
Low Prices	AECO	2033-2034	\$1.90	\$1.89	\$1.93	\$1.84	\$1.74	\$1.61	\$1.60	\$1.58	\$1.43	\$1.45	\$1.59	\$1.70
Low Prices	AECO	2034-2035	\$1.97	\$2.00	\$2.01	\$1.89	\$1.70	\$1.60	\$1.60	\$1.53	\$1.36	\$1.40	\$1.55	\$1.62
Low Prices	AECO	2035-2036	\$1.95	\$2.04	\$2.05	\$2.03	\$1.88	\$1.68	\$1.68	\$1.63	\$1.37	\$1.41	\$1.57	\$1.73
Low Prices	AECO	2036-2037	\$2.07	\$2.10	\$2.12	\$1.95	\$1.83	\$1.64	\$1.77	\$1.73	\$1.51	\$1.58	\$1.71	\$1.85
Low Prices	AECO	2037-2038	\$2.23	\$2.33	\$2.35	\$2.12	\$1.97	\$1.80	\$1.83	\$1.83	\$1.59	\$1.58	\$1.70	\$1.82
Low Prices	AECO	2038-2039	\$2.18	\$2.29	\$2.34	\$2.17	\$2.10	\$1.92	\$1.95	\$1.85	\$1.65	\$1.64	\$1.82	\$1.97
Low Prices	AECO	2039-2040	\$2.38	\$2.45	\$2.45	\$2.32	\$2.21	\$2.03	\$2.04	\$2.01	\$1.83	\$1.84	\$1.98	\$2.10
			Nominal \$											
Scenario	Index	Gas Year	Nov	Dec	Jan	Feb	Mar	Apr	May	Jun	Jul	Aug	Sep	Oct
Low Prices	Malin	2019-2020	\$2.85	\$2.95	\$2.20	\$1.80	\$1.43	\$1.24	\$1.14	\$0.95	\$0.95	\$1.31	\$1.28	\$1.38
Low Prices	Malin	2020-2021	\$1.86	\$2.58	\$2.05	\$1.98	\$1.72	\$1.33	\$1.29	\$1.28	\$1.43	\$1.48	\$1.55	\$1.55
Low Prices	Malin	2021-2022	\$1.78	\$1.89	\$1.93	\$1.87	\$1.72	\$1.21	\$1.16	\$1.17	\$1.25	\$1.26	\$1.27	\$1.27
Low Prices	Malin	2022-2023	\$1.56	\$1.71	\$1.79	\$1.74	\$1.62	\$1.14	\$1.02	\$1.04	\$1.08	\$1.10	\$1.19	\$1.20
Low Prices	Malin	2023-2024	\$1.32	\$1.48	\$1.56	\$1.42	\$1.32	\$1.00	\$0.97	\$0.98	\$1.02	\$1.06	\$1.33	\$1.37
Low Prices	Malin	2024-2025	\$1.44	\$1.54	\$1.64	\$1.60	\$1.50	\$1.36	\$1.35	\$1.29	\$1.31	\$1.35	\$1.57	\$1.57
Low Prices	Malin	2025-2026	\$1.70	\$1.82	\$1.96	\$1.89	\$1.77	\$1.56	\$1.48	\$1.44	\$1.47	\$1.58	\$1.82	\$1.83
Low Prices	Malin	2026-2027	\$1.95	\$2.03	\$2.06	\$1.98	\$1.83	\$1.75	\$1.68	\$1.61	\$1.65	\$1.78	\$1.97	\$1.98
Low Prices	Malin	2027-2028	\$2.16	\$2.27	\$2.28	\$2.04	\$1.96	\$1.73	\$1.69	\$1.72	\$1.74	\$1.90	\$2.09	\$2.12
Low Prices	Malin	2028-2029	\$2.30	\$2.43	\$2.43	\$2.17	\$2.03	\$1.86	\$1.80	\$1.77	\$1.83	\$1.97	\$2.16	\$2.17
Low Prices	Malin	2029-2030	\$2.39	\$2.60	\$2.60	\$2.33	\$2.13	\$1.96	\$1.88	\$1.93	\$1.89	\$2.08	\$2.20	\$2.25
Low Prices	Malin	2030-2031	\$2.48	\$2.66	\$2.62	\$2.39	\$2.19	\$2.08	\$1.92	\$1.91	\$1.98	\$2.15	\$2.37	\$2.39
Low Prices	Malin	2031-2032	\$2.65	\$2.77	\$2.75	\$2.43	\$2.29	\$2.14	\$2.02	\$2.05	\$1.90	\$2.09	\$2.40	\$2.44
Low Prices	Malin	2032-2033	\$2.71	\$2.85	\$2.86	\$2.62	\$2.38	\$2.35	\$2.09	\$2.08	\$2.07	\$2.31	\$2.64	\$2.66
Low Prices	Malin	2033-2034	\$2.95	\$3.02	\$3.02	\$2.74	\$2.49	\$2.46	\$2.27	\$2.33	\$2.24	\$2.46	\$2.78	\$2.82
Low Prices	Malin	2034-2035	\$3.06	\$3.15	\$3.11	\$2.83	\$2.52	\$2.40	\$2.25	\$2.32	\$2.20	\$2.47	\$2.75	\$2.83
Low Prices	Malin	2035-2036	\$3.10	\$3.23	\$3.16	\$2.87	\$2.66	\$2.49	\$2.29	\$2.34	\$2.12	\$2.49	\$2.82	\$2.89
Low Prices	Malin	2036-2037	\$3.18	\$3.33	\$3.33	\$3.07	\$2.78	\$2.57	\$2.41	\$2.43	\$2.18	\$2.56	\$2.85	\$2.96
Low Prices	Malin	2037-2038	\$3.28	\$3.45	\$3.41	\$3.14	\$2.95	\$2.62	\$2.52	\$2.58	\$2.35	\$2.74	\$3.03	\$3.09
Low Prices	Malin	2038-2039	\$3.35	\$3.45	\$3.47	\$3.19	\$3.08	\$2.73	\$2.63	\$2.64	\$2.43	\$2.83	\$3.06	\$3.21
Low Prices	Malin	2039-2040	\$3.53	\$3.70	\$3.58	\$3.29	\$3.09	\$2.86	\$2.75	\$2.66	\$2.64	\$2.93	\$3.22	\$3.32

			Nominal \$											
Scenario	Index	Gas Year	Nov	Dec	Jan	Feb	Mar	Apr	May	Jun	Jul	Aug	Sep	Oct
Low Prices	Rockies	2019-2020	\$2.81	\$2.93	\$2.18	\$1.76	\$1.36	\$1.12	\$1.02	\$0.87	\$0.86	\$1.22	\$1.19	\$1.29
Low Prices	Rockies	2020-2021	\$1.79	\$2.44	\$1.93	\$1.87	\$1.65	\$1.25	\$1.22	\$1.20	\$1.36	\$1.40	\$1.48	\$1.47
Low Prices	Rockies	2021-2022	\$1.70	\$1.81	\$1.85	\$1.79	\$1.64	\$1.13	\$1.08	\$1.10	\$1.17	\$1.18	\$1.19	\$1.19
Low Prices	Rockies	2022-2023	\$1.48	\$1.65	\$1.67	\$1.57	\$1.37	\$1.01	\$0.97	\$1.00	\$1.03	\$1.05	\$1.14	\$1.16
Low Prices	Rockies	2023-2024	\$1.33	\$1.51	\$1.63	\$1.51	\$1.36	\$0.95	\$0.93	\$0.93	\$0.98	\$1.01	\$1.28	\$1.33
Low Prices	Rockies	2024-2025	\$1.50	\$1.64	\$1.80	\$1.73	\$1.56	\$1.32	\$1.32	\$1.32	\$1.39	\$1.39	\$1.52	\$1.52
Low Prices	Rockies	2025-2026	\$1.73	\$1.87	\$2.05	\$2.01	\$1.83	\$1.52	\$1.48	\$1.48	\$1.61	\$1.64	\$1.77	\$1.78
Low Prices	Rockies	2026-2027	\$1.99	\$2.10	\$2.17	\$2.10	\$1.90	\$1.75	\$1.75	\$1.75	\$1.82	\$1.84	\$1.92	\$1.93
Low Prices	Rockies	2027-2028	\$2.15	\$2.33	\$2.38	\$2.19	\$2.07	\$1.78	\$1.77	\$1.75	\$1.94	\$1.94	\$2.05	\$2.07
Low Prices	Rockies	2028-2029	\$2.27	\$2.49	\$2.53	\$2.30	\$2.15	\$1.87	\$1.85	\$1.85	\$2.02	\$2.02	\$2.12	\$2.13
Low Prices	Rockies	2029-2030	\$2.37	\$2.62	\$2.63	\$2.42	\$2.22	\$1.94	\$1.92	\$1.93	\$2.06	\$2.09	\$2.15	\$2.20
Low Prices	Rockies	2030-2031	\$2.44	\$2.63	\$2.64	\$2.49	\$2.30	\$2.05	\$1.99	\$2.00	\$2.16	\$2.17	\$2.32	\$2.35
Low Prices	Rockies	2031-2032	\$2.60	\$2.73	\$2.76	\$2.57	\$2.42	\$2.14	\$2.08	\$2.08	\$2.09	\$2.12	\$2.35	\$2.39
Low Prices	Rockies	2032-2033	\$2.68	\$2.81	\$2.87	\$2.75	\$2.54	\$2.31	\$2.22	\$2.26	\$2.30	\$2.36	\$2.59	\$2.61
Low Prices	Rockies	2033-2034	\$2.93	\$2.99	\$3.05	\$2.91	\$2.68	\$2.43	\$2.37	\$2.38	\$2.42	\$2.49	\$2.73	\$2.78
Low Prices	Rockies	2034-2035	\$3.06	\$3.13	\$3.15	\$3.02	\$2.73	\$2.44	\$2.39	\$2.40	\$2.41	\$2.55	\$2.71	\$2.78
Low Prices	Rockies	2035-2036	\$3.10	\$3.19	\$3.20	\$3.06	\$2.85	\$2.55	\$2.48	\$2.49	\$2.49	\$2.59	\$2.77	\$2.84
Low Prices	Rockies	2036-2037	\$3.18	\$3.34	\$3.37	\$3.24	\$2.98	\$2.64	\$2.63	\$2.60	\$2.62	\$2.66	\$2.81	\$2.91
Low Prices	Rockies	2037-2038	\$3.30	\$3.49	\$3.51	\$3.33	\$3.08	\$2.76	\$2.75	\$2.77	\$2.82	\$2.86	\$3.01	\$3.07
Low Prices	Rockies	2038-2039	\$3.36	\$3.53	\$3.59	\$3.37	\$3.22	\$2.87	\$2.85	\$2.84	\$2.95	\$2.98	\$3.07	\$3.20
Low Prices	Rockies	2039-2040	\$3.54	\$3.77	\$3.72	\$3.48	\$3.32	\$3.03	\$2.99	\$3.01	\$3.07	\$3.11	\$3.23	\$3.32
			Nominal \$											
Scenario	Index	Gas Year	Nov	Dec	Jan	Feb	Mar	Apr	May	Jun	Jul	Aug	Sep	Oct
Low Prices	Stanfield	2019-2020	\$2.85	\$2.93	\$2.19	\$1.74	\$1.32	\$1.13	\$1.05	\$0.85	\$0.79	\$1.14	\$1.14	\$1.23
Low Prices	Stanfield	2020-2021	\$1.71	\$2.36	\$1.87	\$1.81	\$1.61	\$1.24	\$1.19	\$1.14	\$1.27	\$1.33	\$1.43	\$1.44
Low Prices	Stanfield	2021-2022	\$1.59	\$1.71	\$1.76	\$1.71	\$1.54	\$1.09	\$1.02	\$1.01	\$1.09	\$1.11	\$1.12	\$1.13
Low Prices	Stanfield	2022-2023	\$1.34	\$1.50	\$1.53	\$1.45	\$1.29	\$0.93	\$0.88	\$0.89	\$0.92	\$0.95	\$1.04	\$1.05
Low Prices	Stanfield	2023-2024	\$1.20	\$1.37	\$1.46	\$1.33	\$1.23	\$0.89	\$0.85	\$0.85	\$0.90	\$0.93	\$1.17	\$1.22
Low Prices	Stanfield	2024-2025	\$1.32	\$1.42	\$1.54	\$1.50	\$1.37	\$1.21	\$1.19	\$1.14	\$1.15	\$1.20	\$1.41	\$1.41
Low Prices	Stanfield	2025-2026	\$1.56	\$1.69	\$1.84	\$1.78	\$1.64	\$1.40	\$1.31	\$1.28	\$1.31	\$1.43	\$1.66	\$1.67
Low Prices	Stanfield	2026-2027	\$1.82	\$1.91	\$1.95	\$1.87	\$1.70	\$1.58	\$1.50	\$1.43	\$1.48	\$1.62	\$1.81	\$1.82
Low Prices	Stanfield	2027-2028	\$2.01	\$2.13	\$2.16	\$1.94	\$1.83	\$1.56	\$1.52	\$1.56	\$1.57	\$1.74	\$1.93	\$1.96
Low Prices	Stanfield	2028-2029	\$2.15	\$2.30	\$2.31	\$2.05	\$1.90	\$1.69	\$1.62	\$1.59	\$1.66	\$1.81	\$2.00	\$2.01
Low Prices	Stanfield	2029-2030	\$2.24	\$2.46	\$2.47	\$2.21	\$2.00	\$1.79	\$1.71	\$1.77	\$1.72	\$1.93	\$2.05	\$2.09
Low Prices	Stanfield	2030-2031	\$2.34	\$2.53	\$2.50	\$2.27	\$2.05	\$1.90	\$1.74	\$1.73	\$1.81	\$2.00	\$2.21	\$2.24
Low Prices	Stanfield	2031-2032	\$2.50	\$2.64	\$2.62	\$2.30	\$2.15	\$1.96	\$1.84	\$1.88	\$1.73	\$1.93	\$2.24	\$2.28
Low Prices	Stanfield	2032-2033	\$2.56	\$2.72	\$2.73	\$2.50	\$2.25	\$2.18	\$1.91	\$1.89	\$1.90	\$2.16	\$2.48	\$2.50
Low Prices	Stanfield	2033-2034	\$2.80	\$2.89	\$2.90	\$2.62	\$2.35	\$2.28	\$2.08	\$2.16	\$2.06	\$2.30	\$2.62	\$2.67
Low Prices	Stanfield	2034-2035	\$2.90	\$3.01	\$2.98	\$2.71	\$2.39	\$2.23	\$2.07	\$2.14	\$2.03	\$2.31	\$2.59	\$2.67
Low Prices	Stanfield	2035-2036	\$2.94	\$3.09	\$3.04	\$2.75	\$2.53	\$2.32	\$2.10	\$2.16	\$1.94	\$2.33	\$2.65	\$2.73
Low Prices	Stanfield	2036-2037	\$3.02	\$3.20	\$3.20	\$2.95	\$2.64	\$2.39	\$2.22	\$2.25	\$2.00	\$2.39	\$2.69	\$2.79
Low Prices	Stanfield	2037-2038	\$3.12	\$3.31	\$3.28	\$3.01	\$2.80	\$2.44	\$2.32	\$2.40	\$2.16	\$2.56	\$2.86	\$2.92
Low Prices	Stanfield	2038-2039	\$3.19	\$3.31	\$3.33	\$3.06	\$2.93	\$2.54	\$2.43	\$2.46	\$2.24	\$2.65	\$2.89	\$3.04
Low Prices	Stanfield	2039-2040	\$3.36	\$3.55	\$3.45	\$3.16	\$2.95	\$2.67	\$2.54	\$2.46	\$2.46	\$2.75	\$3.05	\$3.15

			Nominal \$											
Scenario	Index	Gas Year	Nov	Dec	Jan	Feb	Mar	Apr	May	Jun	Jul	Aug	Sep	Oct
Low Prices	Sumas	2019-2020	\$4.11	\$3.20	\$2.28	\$1.70	\$1.36	\$1.14	\$1.03	\$0.88	\$0.89	\$1.31	\$1.25	\$1.45
Low Prices	Sumas	2020-2021	\$2.22	\$3.10	\$2.39	\$2.18	\$1.81	\$1.23	\$1.19	\$1.16	\$1.35	\$1.42	\$1.43	\$1.41
Low Prices	Sumas	2021-2022	\$1.96	\$2.30	\$2.24	\$2.10	\$1.76	\$1.01	\$0.95	\$0.97	\$1.07	\$1.09	\$1.09	\$1.07
Low Prices	Sumas	2022-2023	\$1.71	\$2.11	\$2.11	\$1.97	\$1.62	\$0.95	\$0.89	\$0.92	\$1.00	\$1.02	\$1.04	\$1.04
Low Prices	Sumas	2023-2024	\$1.67	\$2.07	\$2.06	\$1.88	\$1.60	\$0.99	\$0.90	\$0.91	\$0.87	\$0.87	\$0.96	\$0.97
Low Prices	Sumas	2024-2025	\$1.72	\$1.99	\$2.06	\$1.95	\$1.72	\$1.20	\$1.09	\$1.01	\$1.00	\$0.99	\$1.11	\$1.45
Low Prices	Sumas	2025-2026	\$1.83	\$2.20	\$2.25	\$2.13	\$1.81	\$1.50	\$1.21	\$1.18	\$1.14	\$1.16	\$1.27	\$1.68
Low Prices	Sumas	2026-2027	\$1.98	\$2.41	\$2.40	\$2.09	\$1.88	\$1.67	\$1.32	\$1.27	\$1.23	\$1.25	\$1.35	\$1.75
Low Prices	Sumas	2027-2028	\$2.15	\$2.35	\$2.40	\$2.18	\$2.05	\$1.45	\$1.36	\$1.33	\$1.30	\$1.32	\$1.46	\$2.04
Low Prices	Sumas	2028-2029	\$2.27	\$2.53	\$2.55	\$2.30	\$2.12	\$1.79	\$1.43	\$1.40	\$1.36	\$1.35	\$1.49	\$2.08
Low Prices	Sumas	2029-2030	\$2.37	\$2.66	\$2.65	\$2.41	\$2.20	\$1.88	\$1.47	\$1.43	\$1.40	\$1.41	\$1.50	\$1.95
Low Prices	Sumas	2030-2031	\$2.44	\$2.67	\$2.68	\$2.48	\$2.26	\$1.97	\$1.55	\$1.51	\$1.44	\$1.43	\$1.59	\$2.00
Low Prices	Sumas	2031-2032	\$2.61	\$2.78	\$2.80	\$2.56	\$2.39	\$2.03	\$1.57	\$1.51	\$1.30	\$1.30	\$1.54	\$2.00
Low Prices	Sumas	2032-2033	\$2.69	\$2.86	\$2.92	\$2.74	\$2.53	\$2.17	\$1.73	\$1.73	\$1.55	\$1.57	\$1.75	\$2.18
Low Prices	Sumas	2033-2034	\$2.94	\$3.05	\$3.09	\$2.90	\$2.66	\$2.26	\$1.84	\$1.81	\$1.67	\$1.69	\$1.88	\$2.36
Low Prices	Sumas	2034-2035	\$3.06	\$3.18	\$3.20	\$3.02	\$2.71	\$2.25	\$1.84	\$1.78	\$1.60	\$1.65	\$1.84	\$2.30
Low Prices	Sumas	2035-2036	\$3.10	\$3.23	\$3.25	\$3.06	\$2.84	\$2.23	\$1.92	\$1.88	\$1.61	\$1.65	\$1.84	\$2.30
Low Prices	Sumas	2036-2037	\$3.19	\$3.38	\$3.41	\$3.24	\$2.96	\$2.20	\$2.01	\$1.98	\$1.75	\$1.82	\$1.98	\$2.41
Low Prices	Sumas	2037-2038	\$3.30	\$3.51	\$3.53	\$3.33	\$3.08	\$2.34	\$2.06	\$2.04	\$1.80	\$1.80	\$1.92	\$2.38
Low Prices	Sumas	2038-2039	\$3.37	\$3.54	\$3.60	\$3.37	\$3.22	\$2.46	\$2.19	\$2.07	\$1.87	\$1.86	\$2.05	\$2.53
Low Prices	Sumas	2039-2040	\$3.55	\$3.77	\$3.72	\$3.48	\$3.26	\$2.58	\$2.28	\$2.24	\$2.06	\$2.07	\$2.21	\$2.64

APPENDIX 6.1: MONTHLY PRICE DATA BY BASIN

LOW GROWTH HIGH PRICE

			Nominal \$											
Scenario	Index	Gas Year	Nov	Dec	Jan	Feb	Mar	Apr	May	Jun	Jul	Aug	Sep	Oct
High Prices	AECO	2019-2020	\$ 2.13	\$ 1.84	\$ 1.77	\$ 1.41	\$ 1.23	\$ 1.01	\$ 1.12	\$ 0.88	\$ 0.85	\$ 1.08	\$ 0.97	\$ 1.00
High Prices	AECO	2020-2021	\$ 1.77	\$ 2.32	\$ 4.38	\$ 4.25	\$ 3.86	\$ 3.27	\$ 3.15	\$ 3.21	\$ 3.39	\$ 3.39	\$ 3.23	\$ 3.27
High Prices	AECO	2021-2022	\$ 3.65	\$ 4.01	\$ 4.16	\$ 3.94	\$ 3.56	\$ 2.78	\$ 2.70	\$ 2.83	\$ 3.01	\$ 2.96	\$ 2.76	\$ 2.75
High Prices	AECO	2022-2023	\$ 3.06	\$ 3.71	\$ 3.95	\$ 3.74	\$ 3.37	\$ 2.88	\$ 2.82	\$ 2.98	\$ 3.10	\$ 3.11	\$ 2.82	\$ 2.90
High Prices	AECO	2023-2024	\$ 3.48	\$ 3.96	\$ 4.36	\$ 4.02	\$ 3.96	\$ 3.48	\$ 3.46	\$ 3.46	\$ 3.47	\$ 3.48	\$ 3.54	\$ 3.58
High Prices	AECO	2024-2025	\$ 3.91	\$ 4.25	\$ 4.87	\$ 4.73	\$ 4.53	\$ 4.18	\$ 4.26	\$ 4.19	\$ 4.26	\$ 4.27	\$ 4.37	\$ 4.36
High Prices	AECO	2025-2026	\$ 4.73	\$ 4.91	\$ 5.63	\$ 5.55	\$ 5.37	\$ 4.98	\$ 5.01	\$ 5.01	\$ 5.10	\$ 5.16	\$ 5.15	\$ 5.20
High Prices	AECO	2026-2027	\$ 5.64	\$ 5.83	\$ 6.11	\$ 6.00	\$ 5.77	\$ 5.42	\$ 5.50	\$ 5.45	\$ 5.54	\$ 5.54	\$ 5.60	\$ 5.55
High Prices	AECO	2027-2028	\$ 6.06	\$ 6.27	\$ 6.42	\$ 6.26	\$ 6.11	\$ 5.75	\$ 5.87	\$ 5.85	\$ 5.90	\$ 5.94	\$ 5.96	\$ 6.15
High Prices	AECO	2028-2029	\$ 6.52	\$ 6.60	\$ 6.77	\$ 6.60	\$ 6.42	\$ 6.05	\$ 6.15	\$ 6.14	\$ 6.25	\$ 6.25	\$ 6.22	\$ 6.27
High Prices	AECO	2029-2030	\$ 6.71	\$ 7.05	\$ 7.10	\$ 6.99	\$ 6.85	\$ 6.44	\$ 6.48	\$ 6.47	\$ 6.52	\$ 6.57	\$ 6.61	\$ 6.77
High Prices	AECO	2030-2031	\$ 7.13	\$ 7.32	\$ 7.34	\$ 7.17	\$ 6.99	\$ 6.65	\$ 6.75	\$ 6.77	\$ 6.79	\$ 6.81	\$ 6.83	\$ 6.89
High Prices	AECO	2031-2032	\$ 7.58	\$ 7.82	\$ 7.83	\$ 7.64	\$ 7.41	\$ 7.14	\$ 7.18	\$ 7.15	\$ 7.01	\$ 7.04	\$ 7.21	\$ 7.33
High Prices	AECO	2032-2033	\$ 7.81	\$ 8.24	\$ 8.40	\$ 8.12	\$ 8.01	\$ 7.63	\$ 7.68	\$ 7.70	\$ 7.60	\$ 7.69	\$ 7.76	\$ 7.89
High Prices	AECO	2033-2034	\$ 8.50	\$ 8.68	\$ 8.79	\$ 8.63	\$ 8.37	\$ 8.18	\$ 8.23	\$ 8.21	\$ 8.37	\$ 8.48	\$ 8.33	\$ 8.55
High Prices	AECO	2034-2035	\$ 9.10	\$ 9.65	\$ 9.67	\$ 9.34	\$ 9.09	\$ 8.69	\$ 8.71	\$ 8.68	\$ 8.65	\$ 8.72	\$ 8.74	\$ 8.83
High Prices	AECO	2035-2036	\$ 9.41	\$ 9.70	\$ 9.79	\$ 9.48	\$ 9.13	\$ 8.79	\$ 8.79	\$ 8.86	\$ 8.84	\$ 8.86	\$ 8.93	\$ 9.09
High Prices	AECO	2036-2037	\$ 9.57	\$10.03	\$10.24	\$10.01	\$ 9.45	\$ 9.05	\$ 9.23	\$ 9.19	\$ 9.19	\$ 9.31	\$ 9.29	\$ 9.40
High Prices	AECO	2037-2038	\$10.31	\$10.75	\$10.82	\$10.04	\$ 9.55	\$ 9.31	\$ 9.49	\$ 9.50	\$ 9.49	\$ 9.53	\$ 9.58	\$ 9.71
High Prices	AECO	2038-2039	\$10.59	\$11.19	\$11.31	\$10.94	\$10.68	\$10.24	\$10.28	\$10.24	\$10.34	\$10.34	\$10.51	\$10.57
High Prices	AECO	2039-2040	\$11.75	\$12.07	\$12.11	\$11.86	\$11.47	\$11.09	\$11.15	\$11.12	\$11.13	\$11.13	\$11.27	\$11.38
			Nominal \$											
Scenario	Index	Gas Year	Nov	Dec	Jan	Feb	Mar	Apr	May	Jun	Jul	Aug	Sep	Oct
High Prices	Malin	2019-2020	\$ 2.85	\$ 2.95	\$ 2.20	\$ 1.80	\$ 1.43	\$ 1.24	\$ 1.14	\$ 0.95	\$ 0.95	\$ 1.31	\$ 1.28	\$ 1.38
High Prices	Malin	2020-2021	\$ 1.86	\$ 2.58	\$ 4.68	\$ 4.57	\$ 4.24	\$ 3.71	\$ 3.66	\$ 3.65	\$ 3.88	\$ 3.93	\$ 3.99	\$ 4.01
High Prices	Malin	2021-2022	\$ 4.28	\$ 4.52	\$ 4.63	\$ 4.50	\$ 4.24	\$ 3.48	\$ 3.37	\$ 3.42	\$ 3.53	\$ 3.56	\$ 3.53	\$ 3.53
High Prices	Malin	2022-2023	\$ 3.87	\$ 4.23	\$ 4.49	\$ 4.43	\$ 4.17	\$ 3.61	\$ 3.45	\$ 3.48	\$ 3.59	\$ 3.61	\$ 3.68	\$ 3.70
High Prices	Malin	2023-2024	\$ 3.92	\$ 4.36	\$ 4.70	\$ 4.51	\$ 4.39	\$ 3.87	\$ 3.83	\$ 3.84	\$ 3.93	\$ 3.98	\$ 4.22	\$ 4.30
High Prices	Malin	2024-2025	\$ 4.58	\$ 4.82	\$ 5.37	\$ 5.29	\$ 5.11	\$ 4.77	\$ 4.75	\$ 4.70	\$ 4.80	\$ 4.86	\$ 5.07	\$ 5.07
High Prices	Malin	2025-2026	\$ 5.39	\$ 5.54	\$ 6.24	\$ 6.14	\$ 5.96	\$ 5.53	\$ 5.45	\$ 5.44	\$ 5.60	\$ 5.75	\$ 5.92	\$ 5.94
High Prices	Malin	2026-2027	\$ 6.31	\$ 6.50	\$ 6.70	\$ 6.59	\$ 6.36	\$ 6.08	\$ 6.03	\$ 5.96	\$ 6.13	\$ 6.25	\$ 6.43	\$ 6.41
High Prices	Malin	2027-2028	\$ 6.83	\$ 7.04	\$ 7.16	\$ 6.87	\$ 6.74	\$ 6.39	\$ 6.39	\$ 6.42	\$ 6.51	\$ 6.69	\$ 6.84	\$ 7.00
High Prices	Malin	2028-2029	\$ 7.31	\$ 7.50	\$ 7.57	\$ 7.27	\$ 7.08	\$ 6.71	\$ 6.70	\$ 6.68	\$ 6.89	\$ 7.04	\$ 7.13	\$ 7.15
High Prices	Malin	2029-2030	\$ 7.53	\$ 8.02	\$ 8.03	\$ 7.77	\$ 7.55	\$ 7.14	\$ 7.08	\$ 7.14	\$ 7.24	\$ 7.47	\$ 7.57	\$ 7.67
High Prices	Malin	2030-2031	\$ 8.00	\$ 8.29	\$ 8.27	\$ 7.96	\$ 7.72	\$ 7.41	\$ 7.35	\$ 7.40	\$ 7.56	\$ 7.76	\$ 7.88	\$ 7.91
High Prices	Malin	2031-2032	\$ 8.56	\$ 8.90	\$ 8.88	\$ 8.47	\$ 8.22	\$ 7.91	\$ 7.86	\$ 7.92	\$ 7.85	\$ 8.06	\$ 8.34	\$ 8.41
High Prices	Malin	2032-2033	\$ 8.83	\$ 9.34	\$ 9.46	\$ 8.97	\$ 8.75	\$ 8.46	\$ 8.28	\$ 8.29	\$ 8.36	\$ 8.67	\$ 8.93	\$ 9.00
High Prices	Malin	2033-2034	\$ 9.55	\$ 9.81	\$ 9.89	\$ 9.54	\$ 9.12	\$ 9.02	\$ 8.89	\$ 8.96	\$ 9.18	\$ 9.48	\$ 9.52	\$ 9.68
High Prices	Malin	2034-2035	\$10.18	\$10.80	\$10.78	\$10.27	\$ 9.91	\$ 9.48	\$ 9.37	\$ 9.46	\$ 9.49	\$ 9.79	\$ 9.94	\$10.04
High Prices	Malin	2035-2036	\$10.55	\$10.89	\$10.89	\$10.33	\$ 9.91	\$ 9.59	\$ 9.40	\$ 9.56	\$ 9.59	\$ 9.95	\$10.18	\$10.25
High Prices	Malin	2036-2037	\$10.68	\$11.26	\$11.44	\$11.14	\$10.39	\$ 9.98	\$ 9.86	\$ 9.90	\$ 9.86	\$10.29	\$10.43	\$10.51
High Prices	Malin	2037-2038	\$11.35	\$11.87	\$11.88	\$11.06	\$10.53	\$10.14	\$10.18	\$10.25	\$10.25	\$10.69	\$10.92	\$10.98
High Prices	Malin	2038-2039	\$11.75	\$12.35	\$12.44	\$11.96	\$11.66	\$11.05	\$10.96	\$11.04	\$11.13	\$11.53	\$11.75	\$11.81
High Prices	Malin	2039-2040	\$12.90	\$13.32	\$13.24	\$12.83	\$12.35	\$11.92	\$11.86	\$11.77	\$11.94	\$12.22	\$12.50	\$12.60

Nominal \$														
Scenario	Index	Gas Year	Nov	Dec	Jan	Feb	Mar	Apr	May	Jun	Jul	Aug	Sep	Oct
High Prices	Rockies	2019-2020	\$ 2.81	\$ 2.93	\$ 2.18	\$ 1.76	\$ 1.36	\$ 1.12	\$ 1.02	\$ 0.87	\$ 0.86	\$ 1.22	\$ 1.19	\$ 1.29
High Prices	Rockies	2020-2021	\$ 1.79	\$ 2.44	\$ 4.56	\$ 4.46	\$ 4.16	\$ 3.63	\$ 3.58	\$ 3.58	\$ 3.81	\$ 3.85	\$ 3.91	\$ 3.93
High Prices	Rockies	2021-2022	\$ 4.21	\$ 4.45	\$ 4.56	\$ 4.42	\$ 4.16	\$ 3.40	\$ 3.29	\$ 3.34	\$ 3.45	\$ 3.48	\$ 3.45	\$ 3.45
High Prices	Rockies	2022-2023	\$ 3.79	\$ 4.17	\$ 4.37	\$ 4.26	\$ 3.92	\$ 3.48	\$ 3.40	\$ 3.43	\$ 3.55	\$ 3.57	\$ 3.64	\$ 3.65
High Prices	Rockies	2023-2024	\$ 3.92	\$ 4.39	\$ 4.77	\$ 4.59	\$ 4.43	\$ 3.82	\$ 3.79	\$ 3.80	\$ 3.89	\$ 3.93	\$ 4.18	\$ 4.25
High Prices	Rockies	2024-2025	\$ 4.64	\$ 4.92	\$ 5.53	\$ 5.42	\$ 5.18	\$ 4.72	\$ 4.73	\$ 4.73	\$ 4.88	\$ 4.89	\$ 5.02	\$ 5.03
High Prices	Rockies	2025-2026	\$ 5.42	\$ 5.59	\$ 6.33	\$ 6.27	\$ 6.02	\$ 5.49	\$ 5.45	\$ 5.48	\$ 5.74	\$ 5.81	\$ 5.88	\$ 5.89
High Prices	Rockies	2026-2027	\$ 6.34	\$ 6.56	\$ 6.81	\$ 6.72	\$ 6.43	\$ 6.09	\$ 6.10	\$ 6.10	\$ 6.30	\$ 6.31	\$ 6.39	\$ 6.36
High Prices	Rockies	2027-2028	\$ 6.83	\$ 7.11	\$ 7.26	\$ 7.02	\$ 6.85	\$ 6.43	\$ 6.46	\$ 6.45	\$ 6.71	\$ 6.74	\$ 6.80	\$ 6.95
High Prices	Rockies	2028-2029	\$ 7.28	\$ 7.56	\$ 7.67	\$ 7.40	\$ 7.20	\$ 6.72	\$ 6.75	\$ 6.76	\$ 7.08	\$ 7.09	\$ 7.09	\$ 7.10
High Prices	Rockies	2029-2030	\$ 7.51	\$ 8.04	\$ 8.06	\$ 7.86	\$ 7.64	\$ 7.12	\$ 7.12	\$ 7.15	\$ 7.41	\$ 7.48	\$ 7.53	\$ 7.63
High Prices	Rockies	2030-2031	\$ 7.96	\$ 8.26	\$ 8.28	\$ 8.06	\$ 7.83	\$ 7.38	\$ 7.43	\$ 7.49	\$ 7.75	\$ 7.77	\$ 7.83	\$ 7.86
High Prices	Rockies	2031-2032	\$ 8.51	\$ 8.85	\$ 8.89	\$ 8.62	\$ 8.35	\$ 7.91	\$ 7.92	\$ 7.95	\$ 8.04	\$ 8.10	\$ 8.30	\$ 8.37
High Prices	Rockies	2032-2033	\$ 8.81	\$ 9.29	\$ 9.47	\$ 9.10	\$ 8.91	\$ 8.42	\$ 8.42	\$ 8.47	\$ 8.59	\$ 8.71	\$ 8.89	\$ 8.96
High Prices	Rockies	2033-2034	\$ 9.53	\$ 9.78	\$ 9.92	\$ 9.70	\$ 9.31	\$ 9.00	\$ 9.00	\$ 9.01	\$ 9.35	\$ 9.52	\$ 9.48	\$ 9.63
High Prices	Rockies	2034-2035	\$10.18	\$10.78	\$10.82	\$10.46	\$10.12	\$ 9.52	\$ 9.51	\$ 9.55	\$ 9.70	\$ 9.86	\$ 9.90	\$10.00
High Prices	Rockies	2035-2036	\$10.55	\$10.84	\$10.93	\$10.52	\$10.10	\$ 9.65	\$ 9.59	\$ 9.71	\$ 9.96	\$10.05	\$10.13	\$10.21
High Prices	Rockies	2036-2037	\$10.68	\$11.27	\$11.48	\$11.31	\$10.59	\$10.05	\$10.09	\$10.06	\$10.30	\$10.39	\$10.39	\$10.47
High Prices	Rockies	2037-2038	\$11.37	\$11.91	\$11.98	\$11.24	\$10.67	\$10.27	\$10.41	\$10.44	\$10.72	\$10.81	\$10.90	\$10.96
High Prices	Rockies	2038-2039	\$11.77	\$12.43	\$12.56	\$12.15	\$11.80	\$11.19	\$11.18	\$11.23	\$11.65	\$11.68	\$11.76	\$11.80
High Prices	Rockies	2039-2040	\$12.91	\$13.39	\$13.38	\$13.02	\$12.58	\$12.09	\$12.10	\$12.12	\$12.37	\$12.40	\$12.51	\$12.60
Nominal \$														
Scenario	Index	Gas Year	Nov	Dec	Jan	Feb	Mar	Apr	May	Jun	Jul	Aug	Sep	Oct
High Prices	Stanfield	2019-2020	\$ 2.85	\$ 2.93	\$ 2.19	\$ 1.74	\$ 1.32	\$ 1.13	\$ 1.05	\$ 0.85	\$ 0.79	\$ 1.14	\$ 1.14	\$ 1.23
High Prices	Stanfield	2020-2021	\$ 1.71	\$ 2.36	\$ 4.49	\$ 4.40	\$ 4.13	\$ 3.63	\$ 3.55	\$ 3.52	\$ 3.72	\$ 3.79	\$ 3.87	\$ 3.89
High Prices	Stanfield	2021-2022	\$ 4.09	\$ 4.34	\$ 4.47	\$ 4.34	\$ 4.06	\$ 3.36	\$ 3.23	\$ 3.26	\$ 3.37	\$ 3.41	\$ 3.38	\$ 3.39
High Prices	Stanfield	2022-2023	\$ 3.64	\$ 4.02	\$ 4.23	\$ 4.14	\$ 3.84	\$ 3.40	\$ 3.31	\$ 3.32	\$ 3.44	\$ 3.47	\$ 3.53	\$ 3.55
High Prices	Stanfield	2023-2024	\$ 3.80	\$ 4.24	\$ 4.60	\$ 4.41	\$ 4.30	\$ 3.75	\$ 3.71	\$ 3.71	\$ 3.81	\$ 3.85	\$ 4.06	\$ 4.14
High Prices	Stanfield	2024-2025	\$ 4.46	\$ 4.70	\$ 5.27	\$ 5.19	\$ 4.99	\$ 4.62	\$ 4.60	\$ 4.54	\$ 4.64	\$ 4.71	\$ 4.91	\$ 4.91
High Prices	Stanfield	2025-2026	\$ 5.25	\$ 5.42	\$ 6.12	\$ 6.04	\$ 5.83	\$ 5.38	\$ 5.29	\$ 5.28	\$ 5.43	\$ 5.60	\$ 5.76	\$ 5.78
High Prices	Stanfield	2026-2027	\$ 6.17	\$ 6.37	\$ 6.58	\$ 6.49	\$ 6.23	\$ 5.92	\$ 5.86	\$ 5.79	\$ 5.97	\$ 6.09	\$ 6.28	\$ 6.25
High Prices	Stanfield	2027-2028	\$ 6.68	\$ 6.91	\$ 7.04	\$ 6.76	\$ 6.61	\$ 6.22	\$ 6.22	\$ 6.26	\$ 6.35	\$ 6.54	\$ 6.68	\$ 6.84
High Prices	Stanfield	2028-2029	\$ 7.15	\$ 7.36	\$ 7.45	\$ 7.15	\$ 6.95	\$ 6.54	\$ 6.52	\$ 6.50	\$ 6.73	\$ 6.88	\$ 6.97	\$ 6.99
High Prices	Stanfield	2029-2030	\$ 7.38	\$ 7.88	\$ 7.91	\$ 7.65	\$ 7.42	\$ 6.97	\$ 6.90	\$ 6.98	\$ 7.07	\$ 7.32	\$ 7.42	\$ 7.52
High Prices	Stanfield	2030-2031	\$ 7.86	\$ 8.16	\$ 8.14	\$ 7.84	\$ 7.58	\$ 7.23	\$ 7.17	\$ 7.22	\$ 7.39	\$ 7.60	\$ 7.73	\$ 7.75
High Prices	Stanfield	2031-2032	\$ 8.41	\$ 8.77	\$ 8.75	\$ 8.35	\$ 8.08	\$ 7.74	\$ 7.68	\$ 7.75	\$ 7.68	\$ 7.91	\$ 8.19	\$ 8.26
High Prices	Stanfield	2032-2033	\$ 8.68	\$ 9.20	\$ 9.34	\$ 8.85	\$ 8.61	\$ 8.29	\$ 8.10	\$ 8.10	\$ 8.18	\$ 8.52	\$ 8.77	\$ 8.84
High Prices	Stanfield	2033-2034	\$ 9.40	\$ 9.67	\$ 9.76	\$ 9.41	\$ 8.99	\$ 8.85	\$ 8.71	\$ 8.79	\$ 9.00	\$ 9.33	\$ 9.36	\$ 9.52
High Prices	Stanfield	2034-2035	\$10.03	\$10.66	\$10.65	\$10.15	\$ 9.78	\$ 9.31	\$ 9.18	\$ 9.29	\$ 9.32	\$ 9.63	\$ 9.78	\$ 9.88
High Prices	Stanfield	2035-2036	\$10.40	\$10.74	\$10.77	\$10.21	\$ 9.77	\$ 9.42	\$ 9.22	\$ 9.38	\$ 9.41	\$ 9.79	\$10.02	\$10.09
High Prices	Stanfield	2036-2037	\$10.53	\$11.12	\$11.31	\$11.01	\$10.26	\$ 9.80	\$ 9.68	\$ 9.71	\$ 9.68	\$10.12	\$10.27	\$10.35
High Prices	Stanfield	2037-2038	\$11.20	\$11.73	\$11.75	\$10.93	\$10.39	\$ 9.95	\$ 9.98	\$10.07	\$10.06	\$10.51	\$10.75	\$10.81
High Prices	Stanfield	2038-2039	\$11.60	\$12.21	\$12.31	\$11.83	\$11.51	\$10.87	\$10.77	\$10.85	\$10.93	\$11.35	\$11.58	\$11.64
High Prices	Stanfield	2039-2040	\$12.74	\$13.17	\$13.11	\$12.70	\$12.21	\$11.73	\$11.65	\$11.57	\$11.76	\$12.04	\$12.33	\$12.43

Scenario	Index	Gas Year	Nominal \$											
			Nov	Dec	Jan	Feb	Mar	Apr	May	Jun	Jul	Aug	Sep	Oct
High Prices	Sumas	2019-2020	\$ 4.11	\$ 3.20	\$ 2.28	\$ 1.70	\$ 1.36	\$ 1.14	\$ 1.03	\$ 0.88	\$ 0.89	\$ 1.31	\$ 1.25	\$ 1.45
High Prices	Sumas	2020-2021	\$ 2.22	\$ 3.10	\$ 5.01	\$ 4.77	\$ 4.32	\$ 3.61	\$ 3.55	\$ 3.54	\$ 3.80	\$ 3.87	\$ 3.87	\$ 3.86
High Prices	Sumas	2021-2022	\$ 4.46	\$ 4.93	\$ 4.95	\$ 4.73	\$ 4.28	\$ 3.29	\$ 3.17	\$ 3.21	\$ 3.36	\$ 3.39	\$ 3.35	\$ 3.33
High Prices	Sumas	2022-2023	\$ 4.02	\$ 4.63	\$ 4.82	\$ 4.66	\$ 4.17	\$ 3.42	\$ 3.32	\$ 3.36	\$ 3.52	\$ 3.54	\$ 3.54	\$ 3.53
High Prices	Sumas	2023-2024	\$ 4.27	\$ 4.95	\$ 5.21	\$ 4.96	\$ 4.67	\$ 3.86	\$ 3.76	\$ 3.77	\$ 3.78	\$ 3.79	\$ 3.85	\$ 3.89
High Prices	Sumas	2024-2025	\$ 4.86	\$ 5.27	\$ 5.79	\$ 5.64	\$ 5.34	\$ 4.61	\$ 4.50	\$ 4.42	\$ 4.49	\$ 4.50	\$ 4.62	\$ 4.95
High Prices	Sumas	2025-2026	\$ 5.52	\$ 5.92	\$ 6.53	\$ 6.38	\$ 6.00	\$ 5.47	\$ 5.19	\$ 5.18	\$ 5.26	\$ 5.33	\$ 5.37	\$ 5.79
High Prices	Sumas	2026-2027	\$ 6.33	\$ 6.87	\$ 7.03	\$ 6.71	\$ 6.41	\$ 6.00	\$ 5.68	\$ 5.62	\$ 5.71	\$ 5.72	\$ 5.82	\$ 6.18
High Prices	Sumas	2027-2028	\$ 6.83	\$ 7.13	\$ 7.28	\$ 7.00	\$ 6.83	\$ 6.11	\$ 6.05	\$ 6.02	\$ 6.07	\$ 6.12	\$ 6.21	\$ 6.92
High Prices	Sumas	2028-2029	\$ 7.28	\$ 7.59	\$ 7.69	\$ 7.40	\$ 7.17	\$ 6.64	\$ 6.33	\$ 6.32	\$ 6.43	\$ 6.42	\$ 6.46	\$ 7.05
High Prices	Sumas	2029-2030	\$ 7.51	\$ 8.08	\$ 8.09	\$ 7.85	\$ 7.62	\$ 7.06	\$ 6.66	\$ 6.65	\$ 6.75	\$ 6.80	\$ 6.87	\$ 7.38
High Prices	Sumas	2030-2031	\$ 7.96	\$ 8.30	\$ 8.32	\$ 8.05	\$ 7.79	\$ 7.31	\$ 6.98	\$ 7.00	\$ 7.02	\$ 7.04	\$ 7.11	\$ 7.52
High Prices	Sumas	2031-2032	\$ 8.52	\$ 8.91	\$ 8.93	\$ 8.61	\$ 8.32	\$ 7.81	\$ 7.41	\$ 7.38	\$ 7.25	\$ 7.28	\$ 7.49	\$ 7.98
High Prices	Sumas	2032-2033	\$ 8.81	\$ 9.34	\$ 9.52	\$ 9.09	\$ 8.89	\$ 8.28	\$ 7.92	\$ 7.94	\$ 7.84	\$ 7.93	\$ 8.05	\$ 8.52
High Prices	Sumas	2033-2034	\$ 9.54	\$ 9.83	\$ 9.96	\$ 9.69	\$ 9.30	\$ 8.83	\$ 8.47	\$ 8.45	\$ 8.61	\$ 8.72	\$ 8.62	\$ 9.21
High Prices	Sumas	2034-2035	\$10.19	\$10.83	\$10.86	\$10.46	\$10.10	\$ 9.34	\$ 8.95	\$ 8.92	\$ 8.90	\$ 8.97	\$ 9.02	\$ 9.52
High Prices	Sumas	2035-2036	\$10.56	\$10.89	\$10.98	\$10.52	\$10.09	\$ 9.33	\$ 9.04	\$ 9.10	\$ 9.08	\$ 9.11	\$ 9.21	\$ 9.66
High Prices	Sumas	2036-2037	\$10.69	\$11.31	\$11.52	\$11.31	\$10.58	\$ 9.61	\$ 9.47	\$ 9.44	\$ 9.43	\$ 9.56	\$ 9.56	\$ 9.97
High Prices	Sumas	2037-2038	\$11.38	\$11.93	\$12.01	\$11.24	\$10.67	\$ 9.85	\$ 9.72	\$ 9.72	\$ 9.70	\$ 9.75	\$ 9.81	\$10.26
High Prices	Sumas	2038-2039	\$11.78	\$12.44	\$12.57	\$12.15	\$11.80	\$10.78	\$10.53	\$10.47	\$10.57	\$10.57	\$10.74	\$11.12
High Prices	Sumas	2039-2040	\$12.92	\$13.39	\$13.38	\$13.02	\$12.52	\$11.64	\$11.39	\$11.35	\$11.36	\$11.36	\$11.49	\$11.93

APPENDIX 6.2: WEIGHTED AVERAGE COST OF CAPITAL

Avista Corporation Capital Structure and Overall Rate of Return					
WASHINGTON					
From 2019 Rate Case Settlement					
	Cost of Capital	Percent of Total Capital	Cost	Component	After Tax
L/T Debt		51.50%	5.15%	2.65%	2.10%
Common Equity		48.50%	9.40%	4.56%	4.56%
TOTAL		100.00%		7.21%	6.65%
IDAHO					
From 2019 Rate Case Settlement					
	Cost of Capital	Percent of Total Capital	Cost	Component	After Tax
L/T Debt		50.00%	5.20%	2.60%	2.05%
Common Equity		50.00%	9.50%	4.75%	4.75%
TOTAL		100.00%		7.35%	6.80%
OREGON					
From 2020 Rate Case Settlement					
	Cost of Capital	Percent of Total Capital	Cost	Component	After Tax
L/T Debt		50.00%	5.07%	2.54%	2.00%
Common Equity		50.00%	9.40%	4.70%	4.70%
TOTAL		100.00%		7.24%	6.70%
Gas Net Rate Base AMA Thru December 2020					
WA	\$	435,241	48%		
ID	\$	179,466	20%		
OR	\$	292,204	32%		
	\$	906,911			
System Weighted Average Cost of Capital (Nominal)*					6.70%
GDP price deflator					2.00%
Real After Tax WACC					4.36%

APPENDIX 6.3: POTENTIAL SUPPLY SIDE RESOURCE OPTIONS

Fossil Fuel Resources Modeled

Additional Resource	Size	Cost/Rates	Availability	Notes
Unsubscribed GTN Capacity	Up to 50,000 Dth	GTN Rate	2021	Currently available unsubscribed capacity from Kingsgate to Spokane
Medford Lateral Exp	50,000 Dth / Day	\$35M capital + GTN Rate	2022	Additional compression to facilitate more gas to flow from mainline GTN to Medford
Plymouth LNG	241,700 Dth w/70,500 Dth deliverability	NWP Rate	2021	Provides for peaking services and alleviates the need for costly pipeline expansions Pair with excess pipeline MDDO's to create firm transport

Renewable Resources Modeled

Resource	Dth per day	Dth per year	Levelized Cost Per Dth (Year 1)
Distributed Renewable Hydrogen Production - WA	166	60,509	\$53.48
Distributed Renewable Hydrogen Production - OR	166	60,509	\$50.00
Distributed LFG to RNG Production - WA	635	231,790	\$13.53
Centralized LFG to RNG Production - WA	1,814	662,256	\$11.73
Dairy Manure to RNG Production - WA	635	231,790	\$40.70
Wastewater Sludge to RNG Production - WA	513	187,245	\$18.95
Food Waste to RNG Production - WA	298	108,799	\$40.68
Distributed LFG to RNG Production - OR	635	231,790	\$13.53
Centralized LFG to RNG Production - OR	1,814	662,256	\$11.73
Dairy Manure to RNG Production - OR	635	231,790	\$40.23
Wastewater Sludge to RNG Production - OR	513	187,245	\$18.75
Food Waste to RNG Production - OR	298	108,799	\$40.21

APPENDIX 6.4: EXPECTED CASE AVOIDED COST

Annual Avoided Costs ¹															
Nominal \$															
Scenario	Gas Year	ID Both	ID GTN	ID NWP	Klamath Falls	La Grande	Medford GTN	Medford NWP	Roseburg	WA Both	WA GTN	WA NWP	ID Annual	WA Annual	OR Annual
Expected Case	2019-2020	\$1.34	\$1.30	\$1.43	\$1.33	\$1.44	\$1.34	\$1.34	\$1.34	\$1.34	\$1.30	\$1.43	\$1.36	\$1.36	\$1.36
Expected Case	2020-2021	\$1.80	\$1.78	\$2.06	\$1.81	\$2.06	\$1.84	\$1.84	\$1.84	\$1.80	\$1.78	\$2.06	\$1.88	\$1.88	\$1.88
Expected Case	2021-2022	\$1.51	\$1.50	\$1.89	\$1.54	\$1.90	\$1.58	\$1.58	\$1.58	\$1.51	\$1.50	\$1.89	\$1.63	\$1.63	\$1.64
Expected Case	2022-2023	\$1.38	\$1.37	\$1.80	\$1.41	\$1.81	\$1.46	\$1.46	\$1.46	\$1.38	\$1.37	\$1.80	\$1.52	\$1.52	\$1.52
Expected Case	2023-2024	\$1.57	\$1.56	\$1.85	\$1.60	\$1.86	\$1.63	\$1.63	\$1.63	\$1.57	\$1.56	\$1.85	\$1.66	\$1.66	\$1.67
Expected Case	2024-2025	\$1.81	\$1.79	\$2.09	\$1.84	\$2.10	\$1.88	\$1.88	\$1.88	\$1.81	\$1.79	\$2.09	\$1.89	\$1.89	\$1.92
Expected Case	2025-2026	\$2.21	\$2.19	\$2.46	\$2.25	\$2.48	\$2.29	\$2.29	\$2.29	\$2.21	\$2.19	\$2.46	\$2.29	\$2.29	\$2.32
Expected Case	2026-2027	\$2.40	\$2.39	\$2.64	\$2.45	\$2.66	\$2.49	\$2.49	\$2.49	\$2.40	\$2.39	\$2.64	\$2.47	\$2.47	\$2.52
Expected Case	2027-2028	\$2.56	\$2.56	\$2.79	\$2.62	\$2.82	\$2.65	\$2.65	\$2.65	\$2.56	\$2.56	\$2.79	\$2.64	\$2.64	\$2.67
Expected Case	2028-2029	\$2.71	\$2.70	\$2.97	\$2.77	\$2.99	\$2.81	\$2.81	\$2.81	\$2.71	\$2.70	\$2.97	\$2.79	\$2.79	\$2.84
Expected Case	2029-2030	\$2.81	\$2.80	\$3.06	\$2.87	\$3.08	\$2.92	\$2.92	\$2.92	\$2.81	\$2.80	\$3.06	\$2.89	\$2.89	\$2.94
Expected Case	2030-2031	\$2.94	\$2.94	\$3.21	\$3.01	\$3.24	\$3.06	\$3.06	\$3.06	\$2.94	\$2.94	\$3.21	\$3.03	\$3.03	\$3.08
Expected Case	2031-2032	\$3.00	\$3.00	\$3.29	\$3.07	\$3.32	\$3.12	\$3.12	\$3.12	\$3.00	\$3.00	\$3.29	\$3.10	\$3.10	\$3.15
Expected Case	2032-2033	\$3.28	\$3.27	\$3.54	\$3.35	\$3.58	\$3.40	\$3.40	\$3.40	\$3.28	\$3.27	\$3.54	\$3.36	\$3.36	\$3.43
Expected Case	2033-2034	\$3.47	\$3.46	\$3.74	\$3.55	\$3.77	\$3.65	\$3.65	\$3.65	\$3.47	\$3.46	\$3.74	\$3.56	\$3.56	\$3.65
Expected Case	2034-2035	\$3.57	\$3.57	\$3.85	\$3.70	\$3.93	\$3.80	\$3.80	\$3.80	\$3.57	\$3.57	\$3.85	\$3.66	\$3.66	\$3.81
Expected Case	2035-2036	\$3.76	\$3.75	\$4.02	\$3.89	\$4.11	\$3.97	\$3.97	\$3.97	\$3.76	\$3.75	\$4.02	\$3.85	\$3.85	\$3.98
Expected Case	2036-2037	\$3.96	\$3.93	\$4.24	\$4.08	\$4.33	\$4.16	\$4.16	\$4.16	\$3.96	\$3.93	\$4.24	\$4.04	\$4.04	\$4.18
Expected Case	2037-2038	\$4.13	\$4.10	\$4.39	\$4.25	\$4.49	\$4.33	\$4.33	\$4.33	\$4.13	\$4.10	\$4.39	\$4.20	\$4.20	\$4.34
Expected Case	2038-2039	\$4.34	\$4.28	\$4.64	\$4.43	\$4.72	\$4.51	\$4.51	\$4.51	\$4.34	\$4.28	\$4.64	\$4.42	\$4.42	\$4.54
Expected Case	2039-2040	\$4.58	\$4.48	\$4.87	\$4.66	\$4.95	\$4.73	\$4.73	\$4.73	\$4.58	\$4.48	\$4.87	\$4.64	\$4.64	\$4.76

¹ Avoided costs are before Environmental Externalities added

Winter Avoided Costs ¹															
Nominal \$															
Scenario	Gas Year	ID Both	ID GTN	ID NWP	Klamath Falls	La Grande	Medford GTN	Medford NWP	Roseburg	WA Both	WA GTN	WA NWP	ID Annual	WA Annual	OR Annual
Expected Case	2019-2020	\$1.99	\$2.02	\$1.99	\$2.20	\$2.23	\$2.20	\$2.20	\$2.20	\$1.99	\$2.02	\$1.99	\$2.00	\$2.00	\$2.20
Expected Case	2020-2021	\$2.13	\$2.09	\$2.14	\$2.10	\$2.15	\$2.10	\$2.10	\$2.10	\$2.13	\$2.09	\$2.14	\$2.12	\$2.12	\$2.11
Expected Case	2021-2022	\$1.96	\$1.94	\$2.16	\$2.01	\$2.18	\$2.01	\$2.01	\$2.01	\$1.96	\$1.94	\$2.16	\$2.02	\$2.02	\$2.04
Expected Case	2022-2023	\$1.65	\$1.64	\$1.97	\$1.71	\$2.00	\$1.71	\$1.71	\$1.71	\$1.65	\$1.64	\$1.97	\$1.75	\$1.75	\$1.76
Expected Case	2023-2024	\$1.76	\$1.73	\$2.03	\$1.81	\$2.05	\$1.81	\$1.81	\$1.81	\$1.76	\$1.73	\$2.03	\$1.84	\$1.84	\$1.86
Expected Case	2024-2025	\$1.80	\$1.72	\$2.07	\$1.83	\$2.12	\$1.83	\$1.83	\$1.83	\$1.80	\$1.72	\$2.07	\$1.86	\$1.86	\$1.88
Expected Case	2025-2026	\$2.19	\$2.09	\$2.47	\$2.22	\$2.51	\$2.22	\$2.22	\$2.22	\$2.19	\$2.09	\$2.47	\$2.25	\$2.25	\$2.28
Expected Case	2026-2027	\$2.53	\$2.50	\$2.65	\$2.61	\$2.71	\$2.61	\$2.61	\$2.61	\$2.53	\$2.50	\$2.65	\$2.56	\$2.56	\$2.63
Expected Case	2027-2028	\$2.72	\$2.71	\$2.81	\$2.81	\$2.89	\$2.81	\$2.81	\$2.81	\$2.72	\$2.71	\$2.81	\$2.74	\$2.74	\$2.83
Expected Case	2028-2029	\$2.91	\$2.88	\$2.97	\$3.00	\$3.06	\$3.00	\$3.00	\$3.00	\$2.91	\$2.88	\$2.97	\$2.92	\$2.92	\$3.01
Expected Case	2029-2030	\$3.03	\$3.03	\$3.08	\$3.15	\$3.19	\$3.15	\$3.15	\$3.15	\$3.03	\$3.03	\$3.08	\$3.05	\$3.05	\$3.16
Expected Case	2030-2031	\$3.18	\$3.18	\$3.23	\$3.30	\$3.33	\$3.30	\$3.30	\$3.30	\$3.18	\$3.18	\$3.23	\$3.20	\$3.20	\$3.30
Expected Case	2031-2032	\$3.29	\$3.28	\$3.32	\$3.41	\$3.43	\$3.41	\$3.41	\$3.41	\$3.29	\$3.28	\$3.32	\$3.30	\$3.30	\$3.42
Expected Case	2032-2033	\$3.46	\$3.44	\$3.52	\$3.59	\$3.64	\$3.59	\$3.59	\$3.59	\$3.46	\$3.44	\$3.52	\$3.47	\$3.47	\$3.60
Expected Case	2033-2034	\$3.71	\$3.70	\$3.74	\$3.86	\$3.87	\$3.86	\$3.86	\$3.86	\$3.71	\$3.70	\$3.74	\$3.72	\$3.72	\$3.86
Expected Case	2034-2035	\$3.88	\$3.87	\$3.90	\$4.30	\$4.31	\$4.30	\$4.30	\$4.30	\$3.88	\$3.87	\$3.90	\$3.89	\$3.89	\$4.31
Expected Case	2035-2036	\$4.04	\$4.01	\$4.13	\$4.47	\$4.54	\$4.47	\$4.47	\$4.47	\$4.04	\$4.01	\$4.13	\$4.06	\$4.06	\$4.49
Expected Case	2036-2037	\$4.26	\$4.21	\$4.34	\$4.72	\$4.77	\$4.72	\$4.72	\$4.72	\$4.26	\$4.21	\$4.34	\$4.27	\$4.27	\$4.73
Expected Case	2037-2038	\$4.56	\$4.52	\$4.63	\$5.02	\$5.07	\$5.02	\$5.02	\$5.02	\$4.56	\$4.52	\$4.63	\$4.57	\$4.57	\$5.03
Expected Case	2038-2039	\$4.71	\$4.56	\$4.87	\$5.09	\$5.26	\$5.09	\$5.09	\$5.09	\$4.71	\$4.56	\$4.87	\$4.71	\$4.71	\$5.13
Expected Case	2039-2040	\$5.03	\$4.82	\$5.17	\$5.41	\$5.59	\$5.41	\$5.41	\$5.41	\$5.03	\$4.82	\$5.17	\$5.00	\$5.00	\$5.45

¹ Avoided costs are before Environmental Externalities added

APPENDIX 6.4: LOW GROWTH & HIGH PRICES CASE AVOIDED COST

Annual Avoided Costs ¹															
Nominal \$															
Scenario	Gas Year	ID Both	ID GTN	ID NWP	Klamath Falls	La Grande	Medford GTN	Medford NWP	Roseburg	WA Both	WA GTN	WA NWP	ID Annual	WA Annual	OR Annual
Low Growth & High Prices	2019-2020	\$1.34	\$1.30	\$1.43	\$1.33	\$1.44	\$1.34	\$1.34	\$1.34	\$1.34	\$1.30	\$1.43	\$1.36	\$1.36	\$1.36
Low Growth & High Prices	2020-2021	\$3.38	\$3.35	\$3.62	\$3.42	\$3.63	\$3.45	\$3.45	\$3.45	\$3.38	\$3.35	\$3.62	\$3.45	\$3.45	\$3.48
Low Growth & High Prices	2021-2022	\$3.24	\$3.32	\$3.54	\$3.39	\$3.64	\$3.37	\$3.37	\$3.37	\$3.24	\$3.32	\$3.54	\$3.37	\$3.37	\$3.43
Low Growth & High Prices	2022-2023	\$3.19	\$3.27	\$3.51	\$3.33	\$3.60	\$3.31	\$3.31	\$3.31	\$3.19	\$3.27	\$3.51	\$3.32	\$3.32	\$3.37
Low Growth & High Prices	2023-2024	\$3.72	\$3.76	\$3.92	\$3.83	\$3.99	\$3.83	\$3.83	\$3.83	\$3.72	\$3.76	\$3.92	\$3.80	\$3.80	\$3.86
Low Growth & High Prices	2024-2025	\$4.39	\$4.44	\$4.60	\$4.52	\$4.66	\$4.51	\$4.51	\$4.51	\$4.39	\$4.44	\$4.60	\$4.47	\$4.47	\$4.54
Low Growth & High Prices	2025-2026	\$5.21	\$5.25	\$5.44	\$5.35	\$5.50	\$5.34	\$5.34	\$5.34	\$5.21	\$5.25	\$5.44	\$5.30	\$5.30	\$5.37
Low Growth & High Prices	2026-2027	\$5.74	\$5.78	\$5.93	\$5.88	\$5.99	\$5.87	\$5.87	\$5.87	\$5.74	\$5.78	\$5.93	\$5.82	\$5.82	\$5.90
Low Growth & High Prices	2027-2028	\$6.14	\$6.17	\$6.30	\$6.28	\$6.36	\$6.27	\$6.27	\$6.27	\$6.14	\$6.17	\$6.30	\$6.20	\$6.20	\$6.29
Low Growth & High Prices	2028-2029	\$6.47	\$6.48	\$6.65	\$6.60	\$6.70	\$6.59	\$6.59	\$6.59	\$6.47	\$6.48	\$6.65	\$6.53	\$6.53	\$6.61
Low Growth & High Prices	2029-2030	\$6.83	\$6.85	\$7.03	\$6.97	\$7.09	\$6.97	\$6.97	\$6.97	\$6.83	\$6.85	\$7.03	\$6.90	\$6.90	\$6.99
Low Growth & High Prices	2030-2031	\$7.08	\$7.09	\$7.29	\$7.22	\$7.35	\$7.21	\$7.21	\$7.21	\$7.08	\$7.09	\$7.29	\$7.15	\$7.15	\$7.24
Low Growth & High Prices	2031-2032	\$7.49	\$7.51	\$7.73	\$7.65	\$7.80	\$7.63	\$7.63	\$7.63	\$7.49	\$7.51	\$7.73	\$7.58	\$7.58	\$7.67
Low Growth & High Prices	2032-2033	\$8.00	\$8.04	\$8.24	\$8.18	\$8.32	\$8.17	\$8.17	\$8.17	\$8.00	\$8.04	\$8.24	\$8.09	\$8.09	\$8.20
Low Growth & High Prices	2033-2034	\$8.61	\$8.61	\$8.86	\$8.77	\$8.90	\$8.75	\$8.75	\$8.75	\$8.61	\$8.61	\$8.86	\$8.69	\$8.69	\$8.79
Low Growth & High Prices	2034-2035	\$9.09	\$9.17	\$9.31	\$9.33	\$9.44	\$9.32	\$9.32	\$9.32	\$9.09	\$9.17	\$9.31	\$9.19	\$9.19	\$9.35
Low Growth & High Prices	2035-2036	\$9.29	\$9.32	\$9.52	\$9.49	\$9.61	\$9.47	\$9.47	\$9.47	\$9.29	\$9.32	\$9.52	\$9.38	\$9.38	\$9.50
Low Growth & High Prices	2036-2037	\$9.59	\$9.68	\$9.79	\$9.86	\$9.94	\$9.83	\$9.83	\$9.83	\$9.59	\$9.68	\$9.79	\$9.69	\$9.69	\$9.86
Low Growth & High Prices	2037-2038	\$9.92	\$10.04	\$10.14	\$10.22	\$10.32	\$10.19	\$10.19	\$10.19	\$9.92	\$10.04	\$10.14	\$10.03	\$10.03	\$10.22
Low Growth & High Prices	2038-2039	\$10.74	\$10.82	\$10.97	\$11.01	\$11.11	\$10.99	\$10.99	\$10.99	\$10.74	\$10.82	\$10.97	\$10.85	\$10.85	\$11.02
Low Growth & High Prices	2039-2040	\$11.66	\$11.69	\$11.89	\$11.90	\$11.98	\$11.87	\$11.87	\$11.87	\$11.66	\$11.69	\$11.89	\$11.75	\$11.75	\$11.90

¹ Avoided costs are before Environmental Externalities added

Winter Avoided Costs ¹															
Nominal \$															
Scenario	Gas Year	ID Both	ID GTN	ID NWP	Klamath Falls	La Grande	Medford GTN	Medford NWP	Roseburg	WA Both	WA GTN	WA NWP	ID Annual	WA Annual	OR Annual
Low Growth & High Prices	2019-2020	\$1.99	\$2.02	\$1.99	\$2.20	\$2.23	\$2.20	\$2.20	\$2.20	\$1.99	\$2.02	\$1.99	\$2.00	\$2.00	\$2.20
Low Growth & High Prices	2020-2021	\$2.31	\$2.09	\$2.32	\$2.13	\$2.32	\$2.18	\$2.18	\$2.18	\$2.31	\$2.09	\$2.32	\$2.24	\$2.24	\$2.20
Low Growth & High Prices	2021-2022	\$3.75	\$3.91	\$3.75	\$3.98	\$3.98	\$3.98	\$3.98	\$3.98	\$3.75	\$3.91	\$3.75	\$3.81	\$3.81	\$3.98
Low Growth & High Prices	2022-2023	\$3.34	\$3.46	\$3.53	\$3.52	\$3.68	\$3.52	\$3.52	\$3.52	\$3.34	\$3.46	\$3.53	\$3.44	\$3.44	\$3.56
Low Growth & High Prices	2023-2024	\$3.80	\$3.80	\$4.01	\$3.87	\$4.05	\$3.87	\$3.87	\$3.87	\$3.80	\$3.80	\$4.01	\$3.87	\$3.87	\$3.91
Low Growth & High Prices	2024-2025	\$4.17	\$4.17	\$4.57	\$4.25	\$4.57	\$4.25	\$4.25	\$4.25	\$4.17	\$4.17	\$4.57	\$4.30	\$4.30	\$4.31
Low Growth & High Prices	2025-2026	\$4.92	\$4.92	\$5.41	\$5.01	\$5.41	\$5.01	\$5.01	\$5.01	\$4.92	\$4.92	\$5.41	\$5.08	\$5.08	\$5.09
Low Growth & High Prices	2026-2027	\$5.85	\$5.85	\$5.92	\$5.96	\$5.98	\$5.96	\$5.96	\$5.96	\$5.85	\$5.85	\$5.92	\$5.88	\$5.88	\$5.96
Low Growth & High Prices	2027-2028	\$6.26	\$6.29	\$6.29	\$6.40	\$6.40	\$6.40	\$6.40	\$6.40	\$6.26	\$6.29	\$6.29	\$6.28	\$6.28	\$6.40
Low Growth & High Prices	2028-2029	\$6.69	\$6.69	\$6.69	\$6.81	\$6.81	\$6.81	\$6.81	\$6.81	\$6.69	\$6.69	\$6.69	\$6.69	\$6.69	\$6.81
Low Growth & High Prices	2029-2030	\$6.97	\$7.02	\$7.05	\$7.15	\$7.16	\$7.15	\$7.15	\$7.15	\$6.97	\$7.02	\$7.05	\$7.01	\$7.01	\$7.15
Low Growth & High Prices	2030-2031	\$7.33	\$7.37	\$7.33	\$7.51	\$7.51	\$7.51	\$7.51	\$7.51	\$7.33	\$7.37	\$7.33	\$7.34	\$7.34	\$7.51
Low Growth & High Prices	2031-2032	\$7.79	\$7.85	\$7.79	\$8.00	\$8.00	\$8.00	\$8.00	\$8.00	\$7.79	\$7.85	\$7.79	\$7.81	\$7.81	\$8.00
Low Growth & High Prices	2032-2033	\$8.13	\$8.19	\$8.23	\$8.33	\$8.36	\$8.33	\$8.33	\$8.33	\$8.13	\$8.19	\$8.23	\$8.18	\$8.18	\$8.34
Low Growth & High Prices	2033-2034	\$8.76	\$8.76	\$8.82	\$8.92	\$8.92	\$8.92	\$8.92	\$8.92	\$8.76	\$8.76	\$8.82	\$8.78	\$8.78	\$8.92
Low Growth & High Prices	2034-2035	\$9.36	\$9.56	\$9.37	\$9.74	\$9.73	\$9.74	\$9.74	\$9.74	\$9.36	\$9.56	\$9.37	\$9.43	\$9.43	\$9.74
Low Growth & High Prices	2035-2036	\$9.67	\$9.75	\$9.67	\$9.92	\$9.92	\$9.92	\$9.92	\$9.92	\$9.67	\$9.75	\$9.67	\$9.69	\$9.69	\$9.92
Low Growth & High Prices	2036-2037	\$9.84	\$10.00	\$9.85	\$10.18	\$10.18	\$10.18	\$10.18	\$10.18	\$9.84	\$10.00	\$9.85	\$9.90	\$9.90	\$10.18
Low Growth & High Prices	2037-2038	\$10.36	\$10.74	\$10.36	\$10.94	\$10.94	\$10.94	\$10.94	\$10.94	\$10.36	\$10.74	\$10.36	\$10.49	\$10.49	\$10.94
Low Growth & High Prices	2038-2039	\$10.94	\$11.11	\$11.00	\$11.31	\$11.31	\$11.31	\$11.31	\$11.31	\$10.94	\$11.11	\$11.00	\$11.02	\$11.02	\$11.31
Low Growth & High Prices	2039-2040	\$12.08	\$12.15	\$12.08	\$12.37	\$12.37	\$12.37	\$12.37	\$12.37	\$12.08	\$12.15	\$12.08	\$12.10	\$12.10	\$12.37

¹ Avoided costs are before Environmental Externalities added

APPENDIX 6.4: HIGH GROWTH & LOW PRICES CASE AVOIDED COST

Annual Avoided Costs ¹															
Nominal \$															
Scenario	Gas Year	ID Both	ID GTN	ID NWP	Klamath Falls	La Grande	Medford GTN	Medford NWP	Roseburg	WA Both	WA GTN	WA NWP	ID Annual	WA Annual	OR Annual
High Growth & Low Prices	2019-2020	\$1.34	\$1.30	\$1.43	\$1.33	\$1.44	\$1.34	\$1.34	\$1.34	\$1.34	\$1.30	\$1.43	\$1.36	\$1.36	\$1.36
High Growth & Low Prices	2020-2021	\$1.27	\$1.26	\$1.54	\$1.28	\$1.57	\$1.31	\$1.31	\$1.31	\$1.27	\$1.26	\$1.54	\$1.36	\$1.36	\$1.36
High Growth & Low Prices	2021-2022	\$0.95	\$0.87	\$1.32	\$0.92	\$1.33	\$0.96	\$0.96	\$0.96	\$0.95	\$0.87	\$1.32	\$1.05	\$1.05	\$1.02
High Growth & Low Prices	2022-2023	\$0.78	\$0.71	\$1.18	\$0.76	\$1.20	\$0.80	\$0.80	\$0.80	\$0.78	\$0.71	\$1.18	\$0.89	\$0.89	\$0.88
High Growth & Low Prices	2023-2024	\$0.88	\$0.79	\$1.13	\$0.84	\$1.15	\$0.87	\$0.87	\$0.87	\$0.88	\$0.79	\$1.13	\$0.93	\$0.93	\$0.92
High Growth & Low Prices	2024-2025	\$1.03	\$0.89	\$1.33	\$0.96	\$1.35	\$1.04	\$1.04	\$1.04	\$1.03	\$0.89	\$1.33	\$1.08	\$1.08	\$1.09
High Growth & Low Prices	2025-2026	\$1.26	\$1.12	\$1.55	\$1.20	\$1.57	\$1.29	\$1.29	\$1.29	\$1.26	\$1.12	\$1.55	\$1.31	\$1.31	\$1.33
High Growth & Low Prices	2026-2027	\$1.36	\$1.23	\$1.64	\$1.31	\$1.68	\$1.41	\$1.41	\$1.41	\$1.36	\$1.23	\$1.64	\$1.41	\$1.41	\$1.44
High Growth & Low Prices	2027-2028	\$1.45	\$1.31	\$1.74	\$1.38	\$1.79	\$1.47	\$1.47	\$1.47	\$1.45	\$1.31	\$1.74	\$1.50	\$1.50	\$1.52
High Growth & Low Prices	2028-2029	\$1.51	\$1.37	\$1.80	\$1.46	\$1.88	\$1.57	\$1.57	\$1.57	\$1.51	\$1.37	\$1.80	\$1.56	\$1.56	\$1.61
High Growth & Low Prices	2029-2030	\$1.56	\$1.41	\$1.96	\$1.50	\$2.04	\$1.60	\$1.60	\$1.60	\$1.56	\$1.41	\$1.96	\$1.64	\$1.64	\$1.67
High Growth & Low Prices	2030-2031	\$1.60	\$1.45	\$1.99	\$1.59	\$2.09	\$1.70	\$1.70	\$1.70	\$1.60	\$1.45	\$1.99	\$1.68	\$1.68	\$1.75
High Growth & Low Prices	2031-2032	\$1.60	\$1.44	\$2.14	\$1.60	\$2.23	\$1.70	\$1.70	\$1.70	\$1.60	\$1.44	\$2.14	\$1.73	\$1.73	\$1.79
High Growth & Low Prices	2032-2033	\$1.76	\$1.60	\$2.31	\$1.77	\$2.40	\$1.87	\$1.87	\$1.87	\$1.76	\$1.60	\$2.31	\$1.89	\$1.89	\$1.96
High Growth & Low Prices	2033-2034	\$1.89	\$1.73	\$2.46	\$1.90	\$2.54	\$2.01	\$2.01	\$2.01	\$1.89	\$1.73	\$2.46	\$2.03	\$2.03	\$2.09
High Growth & Low Prices	2034-2035	\$1.90	\$1.73	\$2.50	\$1.91	\$2.58	\$2.02	\$2.02	\$2.02	\$1.90	\$1.73	\$2.50	\$2.04	\$2.04	\$2.11
High Growth & Low Prices	2035-2036	\$2.06	\$1.79	\$2.65	\$1.98	\$2.70	\$2.07	\$2.07	\$2.07	\$2.06	\$1.79	\$2.65	\$2.17	\$2.17	\$2.18
High Growth & Low Prices	2036-2037	\$2.14	\$1.86	\$2.71	\$2.07	\$2.76	\$2.16	\$2.16	\$2.16	\$2.14	\$1.86	\$2.71	\$2.24	\$2.24	\$2.26
High Growth & Low Prices	2037-2038	\$2.25	\$1.97	\$2.84	\$2.17	\$2.88	\$2.26	\$2.26	\$2.26	\$2.25	\$1.97	\$2.84	\$2.35	\$2.35	\$2.37
High Growth & Low Prices	2038-2039	\$2.32	\$2.03	\$2.94	\$2.25	\$2.98	\$2.34	\$2.34	\$2.34	\$2.32	\$2.03	\$2.94	\$2.43	\$2.43	\$2.45
High Growth & Low Prices	2039-2040	\$2.47	\$2.19	\$3.08	\$2.41	\$3.12	\$2.50	\$2.50	\$2.50	\$2.47	\$2.19	\$3.08	\$2.58	\$2.58	\$2.61

¹ Avoided costs are before Environmental Externalities adder

Winter Avoided Costs ¹															
Nominal \$															
Scenario	Gas Year	ID Both	ID GTN	ID NWP	Klamath Falls	La Grande	Medford GTN	Medford NWP	Roseburg	WA Both	WA GTN	WA NWP	ID Annual	WA Annual	OR Annual
High Growth & Low Prices	2019-2020	\$1.99	\$2.02	\$1.99	\$2.20	\$2.23	\$2.20	\$2.20	\$2.20	\$1.99	\$2.02	\$1.99	\$2.00	\$2.00	\$2.20
High Growth & Low Prices	2020-2021	\$1.91	\$2.09	\$1.91	\$2.08	\$2.12	\$2.08	\$2.08	\$2.08	\$1.91	\$2.09	\$1.91	\$1.97	\$1.97	\$2.09
High Growth & Low Prices	2021-2022	\$1.48	\$1.28	\$1.64	\$1.42	\$1.66	\$1.42	\$1.42	\$1.42	\$1.48	\$1.28	\$1.64	\$1.47	\$1.47	\$1.47
High Growth & Low Prices	2022-2023	\$1.20	\$0.99	\$1.41	\$1.20	\$1.51	\$1.20	\$1.20	\$1.20	\$1.20	\$0.99	\$1.41	\$1.20	\$1.20	\$1.27
High Growth & Low Prices	2023-2024	\$1.23	\$1.00	\$1.37	\$1.20	\$1.42	\$1.20	\$1.20	\$1.20	\$1.23	\$1.00	\$1.37	\$1.20	\$1.20	\$1.25
High Growth & Low Prices	2024-2025	\$1.24	\$0.89	\$1.51	\$1.18	\$1.56	\$1.18	\$1.18	\$1.18	\$1.24	\$0.89	\$1.51	\$1.21	\$1.21	\$1.26
High Growth & Low Prices	2025-2026	\$1.48	\$1.13	\$1.76	\$1.46	\$1.81	\$1.46	\$1.46	\$1.46	\$1.48	\$1.13	\$1.76	\$1.46	\$1.46	\$1.53
High Growth & Low Prices	2026-2027	\$1.69	\$1.35	\$1.85	\$1.69	\$1.96	\$1.69	\$1.69	\$1.69	\$1.69	\$1.35	\$1.85	\$1.63	\$1.63	\$1.75
High Growth & Low Prices	2027-2028	\$1.87	\$1.47	\$1.98	\$1.76	\$2.11	\$1.76	\$1.76	\$1.76	\$1.87	\$1.47	\$1.98	\$1.77	\$1.77	\$1.83
High Growth & Low Prices	2028-2029	\$1.95	\$1.55	\$2.02	\$1.92	\$2.26	\$1.92	\$1.92	\$1.92	\$1.95	\$1.55	\$2.02	\$1.84	\$1.84	\$1.99
High Growth & Low Prices	2029-2030	\$2.03	\$1.63	\$2.14	\$2.02	\$2.38	\$2.02	\$2.02	\$2.02	\$2.03	\$1.63	\$2.14	\$1.94	\$1.94	\$2.10
High Growth & Low Prices	2030-2031	\$2.08	\$1.68	\$2.17	\$2.05	\$2.41	\$2.05	\$2.05	\$2.05	\$2.08	\$1.68	\$2.17	\$1.98	\$1.98	\$2.12
High Growth & Low Prices	2031-2032	\$2.15	\$1.72	\$2.32	\$2.17	\$2.54	\$2.17	\$2.17	\$2.17	\$2.15	\$1.72	\$2.32	\$2.06	\$2.06	\$2.24
High Growth & Low Prices	2032-2033	\$2.19	\$1.75	\$2.46	\$2.22	\$2.65	\$2.22	\$2.22	\$2.22	\$2.19	\$1.75	\$2.46	\$2.13	\$2.13	\$2.31
High Growth & Low Prices	2033-2034	\$2.40	\$1.93	\$2.67	\$2.43	\$2.85	\$2.43	\$2.43	\$2.43	\$2.40	\$1.93	\$2.67	\$2.33	\$2.33	\$2.52
High Growth & Low Prices	2034-2035	\$2.49	\$2.02	\$2.80	\$2.54	\$2.98	\$2.54	\$2.54	\$2.54	\$2.49	\$2.02	\$2.80	\$2.44	\$2.44	\$2.63
High Growth & Low Prices	2035-2036	\$2.51	\$2.04	\$2.98	\$2.57	\$3.10	\$2.57	\$2.57	\$2.57	\$2.51	\$2.04	\$2.98	\$2.51	\$2.51	\$2.68
High Growth & Low Prices	2036-2037	\$2.63	\$2.13	\$3.17	\$2.72	\$3.27	\$2.72	\$2.72	\$2.72	\$2.63	\$2.13	\$3.17	\$2.64	\$2.64	\$2.83
High Growth & Low Prices	2037-2038	\$2.82	\$2.33	\$3.30	\$2.91	\$3.41	\$2.91	\$2.91	\$2.91	\$2.82	\$2.33	\$3.30	\$2.82	\$2.82	\$3.01
High Growth & Low Prices	2038-2039	\$2.80	\$2.28	\$3.37	\$2.93	\$3.46	\$2.93	\$2.93	\$2.93	\$2.80	\$2.28	\$3.37	\$2.82	\$2.82	\$3.04
High Growth & Low Prices	2039-2040	\$2.98	\$2.47	\$3.55	\$3.12	\$3.68	\$3.12	\$3.12	\$3.12	\$2.98	\$2.47	\$3.55	\$3.00	\$3.00	\$3.23

¹ Avoided costs are before Environmental Externalities adder

APPENDIX 6.4: AVERAGE CASE AVOIDED COST

		Annual Avoided Costs ¹													
		Nominal \$													
Scenario	Gas Year	ID Both	ID GTN	ID NWP	Klamath Falls	La Grande	Medford GTN	Medford NWP	Roseburg	WA Both	WA GTN	WA NWP	ID Annual	WA Annual	OR Annual
Average Case	2019-2020	\$1.30	\$1.30	\$1.38	\$1.32	\$1.40	\$1.32	\$1.32	\$1.32	\$1.30	\$1.30	\$1.38	\$1.32	\$1.32	\$1.34
Average Case	2020-2021	\$1.79	\$1.78	\$2.06	\$1.81	\$2.06	\$1.84	\$1.84	\$1.84	\$1.79	\$1.78	\$2.06	\$1.88	\$1.88	\$1.88
Average Case	2021-2022	\$1.50	\$1.50	\$1.87	\$1.54	\$1.88	\$1.58	\$1.58	\$1.58	\$1.50	\$1.50	\$1.87	\$1.62	\$1.62	\$1.63
Average Case	2022-2023	\$1.37	\$1.37	\$1.80	\$1.40	\$1.80	\$1.45	\$1.45	\$1.45	\$1.37	\$1.37	\$1.80	\$1.52	\$1.52	\$1.51
Average Case	2023-2024	\$1.56	\$1.56	\$1.85	\$1.59	\$1.86	\$1.62	\$1.62	\$1.62	\$1.56	\$1.56	\$1.85	\$1.66	\$1.66	\$1.66
Average Case	2024-2025	\$1.80	\$1.79	\$2.09	\$1.84	\$2.10	\$1.87	\$1.87	\$1.87	\$1.80	\$1.79	\$2.09	\$1.89	\$1.89	\$1.91
Average Case	2025-2026	\$2.20	\$2.19	\$2.47	\$2.24	\$2.48	\$2.28	\$2.28	\$2.28	\$2.20	\$2.19	\$2.47	\$2.29	\$2.29	\$2.31
Average Case	2026-2027	\$2.39	\$2.39	\$2.65	\$2.44	\$2.65	\$2.48	\$2.48	\$2.48	\$2.39	\$2.39	\$2.65	\$2.47	\$2.47	\$2.51
Average Case	2027-2028	\$2.56	\$2.56	\$2.80	\$2.61	\$2.81	\$2.64	\$2.64	\$2.64	\$2.56	\$2.56	\$2.80	\$2.64	\$2.64	\$2.67
Average Case	2028-2029	\$2.71	\$2.70	\$2.97	\$2.76	\$2.98	\$2.80	\$2.80	\$2.80	\$2.71	\$2.70	\$2.97	\$2.79	\$2.79	\$2.83
Average Case	2029-2030	\$2.80	\$2.80	\$3.06	\$2.86	\$3.08	\$2.91	\$2.91	\$2.91	\$2.80	\$2.80	\$3.06	\$2.89	\$2.89	\$2.93
Average Case	2030-2031	\$2.94	\$2.94	\$3.21	\$3.00	\$3.23	\$3.04	\$3.04	\$3.04	\$2.94	\$2.94	\$3.21	\$3.03	\$3.03	\$3.07
Average Case	2031-2032	\$3.00	\$3.00	\$3.30	\$3.06	\$3.31	\$3.11	\$3.11	\$3.11	\$3.00	\$3.00	\$3.30	\$3.10	\$3.10	\$3.14
Average Case	2032-2033	\$3.27	\$3.27	\$3.55	\$3.34	\$3.57	\$3.39	\$3.39	\$3.39	\$3.27	\$3.27	\$3.55	\$3.36	\$3.36	\$3.41
Average Case	2033-2034	\$3.47	\$3.46	\$3.74	\$3.53	\$3.76	\$3.63	\$3.63	\$3.63	\$3.47	\$3.46	\$3.74	\$3.56	\$3.56	\$3.64
Average Case	2034-2035	\$3.57	\$3.57	\$3.86	\$3.64	\$3.88	\$3.74	\$3.74	\$3.74	\$3.57	\$3.57	\$3.86	\$3.67	\$3.67	\$3.74
Average Case	2035-2036	\$3.75	\$3.75	\$4.01	\$3.82	\$4.04	\$3.90	\$3.90	\$3.90	\$3.75	\$3.75	\$4.01	\$3.84	\$3.84	\$3.91
Average Case	2036-2037	\$3.94	\$3.93	\$4.22	\$4.01	\$4.24	\$4.09	\$4.09	\$4.09	\$3.94	\$3.93	\$4.22	\$4.03	\$4.03	\$4.11
Average Case	2037-2038	\$4.11	\$4.10	\$4.39	\$4.18	\$4.41	\$4.25	\$4.25	\$4.25	\$4.11	\$4.10	\$4.39	\$4.20	\$4.20	\$4.27
Average Case	2038-2039	\$4.29	\$4.28	\$4.57	\$4.36	\$4.60	\$4.44	\$4.44	\$4.44	\$4.29	\$4.28	\$4.57	\$4.38	\$4.38	\$4.46
Average Case	2039-2040	\$4.50	\$4.48	\$4.75	\$4.57	\$4.78	\$4.64	\$4.64	\$4.64	\$4.50	\$4.48	\$4.75	\$4.58	\$4.58	\$4.66

¹ Avoided costs are before Environmental Externalities added

		Winter Avoided Costs ¹													
		Nominal \$													
Scenario	Gas Year	ID Both	ID GTN	ID NWP	Klamath Falls	La Grande	Medford GTN	Medford NWP	Roseburg	WA Both	WA GTN	WA NWP	ID Annual	WA Annual	OR Annual
Average Case	2019-2020	\$1.87	\$2.02	\$1.87	\$2.12	\$2.13	\$2.12	\$2.12	\$2.12	\$1.87	\$2.02	\$1.87	\$1.92	\$1.92	\$2.12
Average Case	2020-2021	\$2.13	\$2.09	\$2.13	\$2.09	\$2.14	\$2.09	\$2.09	\$2.09	\$2.13	\$2.09	\$2.13	\$2.12	\$2.12	\$2.10
Average Case	2021-2022	\$1.94	\$1.94	\$2.09	\$1.98	\$2.11	\$1.98	\$1.98	\$1.98	\$1.94	\$1.94	\$2.09	\$1.99	\$1.99	\$2.00
Average Case	2022-2023	\$1.64	\$1.64	\$1.95	\$1.68	\$1.95	\$1.68	\$1.68	\$1.68	\$1.64	\$1.64	\$1.95	\$1.74	\$1.74	\$1.73
Average Case	2023-2024	\$1.74	\$1.73	\$2.03	\$1.78	\$2.03	\$1.78	\$1.78	\$1.78	\$1.74	\$1.73	\$2.03	\$1.83	\$1.83	\$1.83
Average Case	2024-2025	\$1.78	\$1.72	\$2.07	\$1.79	\$2.08	\$1.79	\$1.79	\$1.79	\$1.78	\$1.72	\$2.07	\$1.86	\$1.86	\$1.85
Average Case	2025-2026	\$2.17	\$2.09	\$2.46	\$2.18	\$2.47	\$2.18	\$2.18	\$2.18	\$2.17	\$2.09	\$2.46	\$2.24	\$2.24	\$2.24
Average Case	2026-2027	\$2.52	\$2.50	\$2.65	\$2.57	\$2.66	\$2.57	\$2.57	\$2.57	\$2.52	\$2.50	\$2.65	\$2.56	\$2.56	\$2.59
Average Case	2027-2028	\$2.71	\$2.71	\$2.80	\$2.77	\$2.83	\$2.77	\$2.77	\$2.77	\$2.71	\$2.71	\$2.80	\$2.74	\$2.74	\$2.78
Average Case	2028-2029	\$2.90	\$2.88	\$2.97	\$2.95	\$2.98	\$2.95	\$2.95	\$2.95	\$2.90	\$2.88	\$2.97	\$2.92	\$2.92	\$2.96
Average Case	2029-2030	\$3.03	\$3.03	\$3.08	\$3.09	\$3.12	\$3.09	\$3.09	\$3.09	\$3.03	\$3.03	\$3.08	\$3.04	\$3.04	\$3.10
Average Case	2030-2031	\$3.18	\$3.18	\$3.23	\$3.24	\$3.26	\$3.24	\$3.24	\$3.24	\$3.18	\$3.18	\$3.23	\$3.20	\$3.20	\$3.24
Average Case	2031-2032	\$3.29	\$3.28	\$3.31	\$3.35	\$3.35	\$3.35	\$3.35	\$3.35	\$3.29	\$3.28	\$3.31	\$3.29	\$3.29	\$3.35
Average Case	2032-2033	\$3.46	\$3.44	\$3.51	\$3.53	\$3.56	\$3.53	\$3.53	\$3.53	\$3.46	\$3.44	\$3.51	\$3.47	\$3.47	\$3.54
Average Case	2033-2034	\$3.71	\$3.70	\$3.73	\$3.79	\$3.79	\$3.79	\$3.79	\$3.79	\$3.71	\$3.70	\$3.73	\$3.71	\$3.71	\$3.79
Average Case	2034-2035	\$3.88	\$3.87	\$3.90	\$3.95	\$3.95	\$3.95	\$3.95	\$3.95	\$3.88	\$3.87	\$3.90	\$3.88	\$3.88	\$3.95
Average Case	2035-2036	\$4.02	\$4.01	\$4.08	\$4.09	\$4.13	\$4.09	\$4.09	\$4.09	\$4.02	\$4.01	\$4.08	\$4.03	\$4.03	\$4.10
Average Case	2036-2037	\$4.22	\$4.21	\$4.27	\$4.31	\$4.33	\$4.31	\$4.31	\$4.31	\$4.22	\$4.21	\$4.27	\$4.23	\$4.23	\$4.31
Average Case	2037-2038	\$4.54	\$4.52	\$4.59	\$4.62	\$4.64	\$4.62	\$4.62	\$4.62	\$4.54	\$4.52	\$4.59	\$4.55	\$4.55	\$4.62
Average Case	2038-2039	\$4.60	\$4.56	\$4.68	\$4.68	\$4.75	\$4.68	\$4.68	\$4.68	\$4.60	\$4.56	\$4.68	\$4.61	\$4.61	\$4.69
Average Case	2039-2040	\$4.84	\$4.82	\$4.87	\$4.92	\$4.94	\$4.92	\$4.92	\$4.92	\$4.84	\$4.82	\$4.87	\$4.84	\$4.84	\$4.92

¹ Avoided costs are before Environmental Externalities added

APPENDIX 6.4: CARBON REDUCTION AVOIDED COST

Annual Avoided Costs ¹															
Nominal \$															
Scenario	Gas Year	ID Both	ID GTN	ID NWP	Klamath Falls	La Grande	Medford GTN	Medford NWP	Roseburg	WA Both	WA GTN	WA NWP	ID Annual	WA Annual	OR Annual
Carbon Reduction	2019-2020	\$1.34	\$1.30	\$1.43	\$1.33	\$1.44	\$1.34	\$1.34	\$1.34	\$1.34	\$1.30	\$1.43	\$1.36	\$1.36	\$1.36
Carbon Reduction	2020-2021	\$1.27	\$1.26	\$1.54	\$1.28	\$1.57	\$1.31	\$1.31	\$1.31	\$1.27	\$1.26	\$1.54	\$1.36	\$1.36	\$1.36
Carbon Reduction	2021-2022	\$0.88	\$0.87	\$1.25	\$0.91	\$1.26	\$0.95	\$0.95	\$0.95	\$0.88	\$0.87	\$1.25	\$1.00	\$1.00	\$1.00
Carbon Reduction	2022-2023	\$0.71	\$0.71	\$1.12	\$0.74	\$1.13	\$0.78	\$0.78	\$0.78	\$0.71	\$0.71	\$1.12	\$0.85	\$0.85	\$0.84
Carbon Reduction	2023-2024	\$0.80	\$0.79	\$1.07	\$0.82	\$1.08	\$0.85	\$0.85	\$0.85	\$0.80	\$0.79	\$1.07	\$0.89	\$0.89	\$0.89
Carbon Reduction	2024-2025	\$0.91	\$0.89	\$1.18	\$0.93	\$1.20	\$0.97	\$0.97	\$0.97	\$0.91	\$0.89	\$1.18	\$0.99	\$0.99	\$1.00
Carbon Reduction	2025-2026	\$1.14	\$1.12	\$1.37	\$1.17	\$1.39	\$1.21	\$1.21	\$1.21	\$1.14	\$1.12	\$1.37	\$1.21	\$1.21	\$1.23
Carbon Reduction	2026-2027	\$1.24	\$1.23	\$1.48	\$1.27	\$1.50	\$1.32	\$1.32	\$1.32	\$1.24	\$1.23	\$1.48	\$1.32	\$1.32	\$1.35
Carbon Reduction	2027-2028	\$1.32	\$1.31	\$1.56	\$1.35	\$1.58	\$1.38	\$1.38	\$1.38	\$1.32	\$1.31	\$1.56	\$1.40	\$1.40	\$1.41
Carbon Reduction	2028-2029	\$1.39	\$1.37	\$1.64	\$1.42	\$1.66	\$1.47	\$1.47	\$1.47	\$1.39	\$1.37	\$1.64	\$1.47	\$1.47	\$1.50
Carbon Reduction	2029-2030	\$1.42	\$1.41	\$1.65	\$1.46	\$1.68	\$1.51	\$1.51	\$1.51	\$1.42	\$1.41	\$1.65	\$1.49	\$1.49	\$1.53
Carbon Reduction	2030-2031	\$1.46	\$1.45	\$1.73	\$1.50	\$1.75	\$1.55	\$1.55	\$1.55	\$1.46	\$1.45	\$1.73	\$1.55	\$1.55	\$1.58
Carbon Reduction	2031-2032	\$1.47	\$1.43	\$1.77	\$1.52	\$1.82	\$1.63	\$1.63	\$1.63	\$1.47	\$1.43	\$1.77	\$1.56	\$1.56	\$1.65
Carbon Reduction	2032-2033	\$1.64	\$1.60	\$1.92	\$1.70	\$1.98	\$1.80	\$1.80	\$1.80	\$1.64	\$1.60	\$1.92	\$1.72	\$1.72	\$1.81
Carbon Reduction	2033-2034	\$1.79	\$1.72	\$2.10	\$1.82	\$2.15	\$1.93	\$1.93	\$1.93	\$1.79	\$1.72	\$2.10	\$1.87	\$1.87	\$1.95
Carbon Reduction	2034-2035	\$1.80	\$1.72	\$2.12	\$1.83	\$2.18	\$1.94	\$1.94	\$1.94	\$1.80	\$1.72	\$2.12	\$1.88	\$1.88	\$1.96
Carbon Reduction	2035-2036	\$1.91	\$1.79	\$2.25	\$1.90	\$2.29	\$1.99	\$1.99	\$1.99	\$1.91	\$1.79	\$2.25	\$1.98	\$1.98	\$2.03
Carbon Reduction	2036-2037	\$1.98	\$1.86	\$2.32	\$1.98	\$2.38	\$2.07	\$2.07	\$2.07	\$1.98	\$1.86	\$2.32	\$2.05	\$2.05	\$2.11
Carbon Reduction	2037-2038	\$2.09	\$1.97	\$2.45	\$2.08	\$2.50	\$2.17	\$2.17	\$2.17	\$2.09	\$1.97	\$2.45	\$2.17	\$2.17	\$2.22
Carbon Reduction	2038-2039	\$2.15	\$2.03	\$2.50	\$2.15	\$2.56	\$2.24	\$2.24	\$2.24	\$2.15	\$2.03	\$2.50	\$2.23	\$2.23	\$2.29
Carbon Reduction	2039-2040	\$2.31	\$2.18	\$2.63	\$2.31	\$2.69	\$2.40	\$2.40	\$2.40	\$2.31	\$2.18	\$2.63	\$2.37	\$2.37	\$2.44

¹ Avoided costs are before Environmental Externalities adder

Winter Avoided Costs ¹															
Nominal \$															
Scenario	Gas Year	ID Both	ID GTN	ID NWP	Klamath Falls	La Grande	Medford GTN	Medford NWP	Roseburg	WA Both	WA GTN	WA NWP	ID Annual	WA Annual	OR Annual
Carbon Reduction	2019-2020	\$1.99	\$2.02	\$1.99	\$2.20	\$2.23	\$2.20	\$2.20	\$2.20	\$1.99	\$2.02	\$1.99	\$2.00	\$2.00	\$2.20
Carbon Reduction	2020-2021	\$1.91	\$2.09	\$1.91	\$2.08	\$2.12	\$2.08	\$2.08	\$2.08	\$1.91	\$2.09	\$1.91	\$1.97	\$1.97	\$2.09
Carbon Reduction	2021-2022	\$1.30	\$1.28	\$1.45	\$1.35	\$1.49	\$1.35	\$1.35	\$1.35	\$1.30	\$1.28	\$1.45	\$1.35	\$1.35	\$1.38
Carbon Reduction	2022-2023	\$1.01	\$0.99	\$1.25	\$1.05	\$1.29	\$1.05	\$1.05	\$1.05	\$1.01	\$0.99	\$1.25	\$1.08	\$1.08	\$1.10
Carbon Reduction	2023-2024	\$1.05	\$1.00	\$1.22	\$1.08	\$1.25	\$1.08	\$1.08	\$1.08	\$1.05	\$1.00	\$1.22	\$1.09	\$1.09	\$1.11
Carbon Reduction	2024-2025	\$0.96	\$0.89	\$1.16	\$1.00	\$1.21	\$1.00	\$1.00	\$1.00	\$0.96	\$0.89	\$1.16	\$1.01	\$1.01	\$1.04
Carbon Reduction	2025-2026	\$1.23	\$1.13	\$1.36	\$1.25	\$1.41	\$1.25	\$1.25	\$1.25	\$1.23	\$1.13	\$1.36	\$1.24	\$1.24	\$1.29
Carbon Reduction	2026-2027	\$1.41	\$1.35	\$1.48	\$1.46	\$1.55	\$1.46	\$1.46	\$1.46	\$1.41	\$1.35	\$1.48	\$1.41	\$1.41	\$1.48
Carbon Reduction	2027-2028	\$1.50	\$1.47	\$1.57	\$1.56	\$1.64	\$1.56	\$1.56	\$1.56	\$1.50	\$1.47	\$1.57	\$1.51	\$1.51	\$1.58
Carbon Reduction	2028-2029	\$1.60	\$1.55	\$1.63	\$1.68	\$1.72	\$1.68	\$1.68	\$1.68	\$1.60	\$1.55	\$1.63	\$1.59	\$1.59	\$1.68
Carbon Reduction	2029-2030	\$1.64	\$1.63	\$1.67	\$1.74	\$1.77	\$1.74	\$1.74	\$1.74	\$1.64	\$1.63	\$1.67	\$1.65	\$1.65	\$1.75
Carbon Reduction	2030-2031	\$1.69	\$1.68	\$1.73	\$1.78	\$1.82	\$1.78	\$1.78	\$1.78	\$1.69	\$1.68	\$1.73	\$1.70	\$1.70	\$1.79
Carbon Reduction	2031-2032	\$1.78	\$1.72	\$1.83	\$2.08	\$2.13	\$2.08	\$2.08	\$2.08	\$1.78	\$1.72	\$1.83	\$1.77	\$1.77	\$2.09
Carbon Reduction	2032-2033	\$1.87	\$1.75	\$1.96	\$2.14	\$2.24	\$2.14	\$2.14	\$2.14	\$1.87	\$1.75	\$1.96	\$1.86	\$1.86	\$2.16
Carbon Reduction	2033-2034	\$2.09	\$1.93	\$2.19	\$2.35	\$2.46	\$2.35	\$2.35	\$2.35	\$2.09	\$1.93	\$2.19	\$2.07	\$2.07	\$2.38
Carbon Reduction	2034-2035	\$2.19	\$2.02	\$2.30	\$2.47	\$2.59	\$2.47	\$2.47	\$2.47	\$2.19	\$2.02	\$2.30	\$2.17	\$2.17	\$2.50
Carbon Reduction	2035-2036	\$2.33	\$2.04	\$2.52	\$2.51	\$2.74	\$2.51	\$2.51	\$2.51	\$2.33	\$2.04	\$2.52	\$2.30	\$2.30	\$2.56
Carbon Reduction	2036-2037	\$2.42	\$2.13	\$2.58	\$2.66	\$2.87	\$2.66	\$2.66	\$2.66	\$2.42	\$2.13	\$2.58	\$2.38	\$2.38	\$2.70
Carbon Reduction	2037-2038	\$2.62	\$2.33	\$2.81	\$2.81	\$3.05	\$2.81	\$2.81	\$2.81	\$2.62	\$2.33	\$2.81	\$2.59	\$2.59	\$2.86
Carbon Reduction	2038-2039	\$2.58	\$2.28	\$2.77	\$2.80	\$3.05	\$2.80	\$2.80	\$2.80	\$2.58	\$2.28	\$2.77	\$2.54	\$2.54	\$2.85
Carbon Reduction	2039-2040	\$2.76	\$2.47	\$2.92	\$3.02	\$3.24	\$3.02	\$3.02	\$3.02	\$2.76	\$2.47	\$2.92	\$2.72	\$2.72	\$3.07

¹ Avoided costs are before Environmental Externalities adder

APPENDIX 6.4: LOW GROWTH & HIGH PRICES MONTHLY DETAIL

Table with columns: Scenario, Gas Year, Month, and 15 categories of avoided costs (ID Both, ID GTN, ID NWP, Klamath Falls, La Grande, Medford GTN, Medford NWP, Roseburg, WA Both, WA GTN, WA NWP, Idaho, Washington, Oregon). Values are in Nominal \$.

*Avoided costs are before Environmental Externalities adder

		Monthly Avoided Costs ¹														
		Nominal \$														
Scenario	Gas Year	Month	ID Both	ID GTN	ID NWP	Klamath Falls	La Grande	Medford GTN	Medford NWP	Roseburg	WA Both	WAGTN	WA NWP	Idaho	Washington	Oregon
Low Growth & High Prices	2027-2028	Dec	\$6.33	\$6.40	\$6.33	\$6.51	\$6.51	\$6.51	\$6.51	\$6.51	\$6.33	\$6.40	\$6.33	\$6.36	\$6.36	\$6.51
Low Growth & High Prices	2027-2028	Jan	\$6.33	\$6.55	\$6.33	\$6.67	\$6.67	\$6.67	\$6.67	\$6.67	\$6.33	\$6.55	\$6.33	\$6.41	\$6.41	\$6.67
Low Growth & High Prices	2027-2028	Feb	\$6.34	\$6.39	\$6.34	\$6.50	\$6.44	\$6.41	\$6.41	\$6.41	\$6.34	\$6.39	\$6.34	\$6.36	\$6.36	\$6.44
Low Growth & High Prices	2027-2028	Mar	\$6.23	\$6.23	\$6.24	\$6.34	\$6.34	\$6.34	\$6.34	\$6.34	\$6.23	\$6.23	\$6.24	\$6.23	\$6.23	\$6.34
Low Growth & High Prices	2027-2028	Apr	\$5.86	\$5.86	\$6.21	\$5.97	\$6.21	\$5.97	\$5.97	\$5.97	\$5.86	\$5.86	\$6.21	\$5.98	\$5.98	\$6.02
Low Growth & High Prices	2027-2028	May	\$5.99	\$5.99	\$6.21	\$6.10	\$6.21	\$6.10	\$6.10	\$6.10	\$5.99	\$5.99	\$6.21	\$6.06	\$6.06	\$6.12
Low Growth & High Prices	2027-2028	Jun	\$5.97	\$5.97	\$6.21	\$6.08	\$6.21	\$6.08	\$6.08	\$6.08	\$5.97	\$5.97	\$6.21	\$6.05	\$6.05	\$6.11
Low Growth & High Prices	2027-2028	Jul	\$6.02	\$6.02	\$6.21	\$6.13	\$6.21	\$6.13	\$6.13	\$6.13	\$6.02	\$6.02	\$6.21	\$6.08	\$6.08	\$6.15
Low Growth & High Prices	2027-2028	Aug	\$6.06	\$6.06	\$6.21	\$6.17	\$6.21	\$6.17	\$6.17	\$6.17	\$6.06	\$6.06	\$6.21	\$6.11	\$6.11	\$6.18
Low Growth & High Prices	2027-2028	Sep	\$6.08	\$6.08	\$6.21	\$6.19	\$6.21	\$6.19	\$6.19	\$6.19	\$6.08	\$6.08	\$6.21	\$6.12	\$6.12	\$6.19
Low Growth & High Prices	2027-2028	Oct	\$6.28	\$6.28	\$6.82	\$6.39	\$6.82	\$6.39	\$6.39	\$6.39	\$6.28	\$6.28	\$6.82	\$6.46	\$6.46	\$6.48
Low Growth & High Prices	2028-2029	Nov	\$6.65	\$6.65	\$6.65	\$6.77	\$6.77	\$6.77	\$6.77	\$6.77	\$6.65	\$6.65	\$6.65	\$6.65	\$6.65	\$6.77
Low Growth & High Prices	2028-2029	Dec	\$6.73	\$6.73	\$6.73	\$6.85	\$6.85	\$6.85	\$6.85	\$6.85	\$6.73	\$6.73	\$6.73	\$6.73	\$6.73	\$6.85
Low Growth & High Prices	2028-2029	Jan	\$6.75	\$6.90	\$6.75	\$7.03	\$7.03	\$7.03	\$7.03	\$7.03	\$6.75	\$6.90	\$6.75	\$6.80	\$6.80	\$7.03
Low Growth & High Prices	2028-2029	Feb	\$6.73	\$6.73	\$6.73	\$6.86	\$6.78	\$6.73	\$6.73	\$6.73	\$6.73	\$6.73	\$6.73	\$6.73	\$6.73	\$6.77
Low Growth & High Prices	2028-2029	Mar	\$6.55	\$6.55	\$6.69	\$6.67	\$6.70	\$6.67	\$6.67	\$6.67	\$6.55	\$6.55	\$6.69	\$6.60	\$6.60	\$6.68
Low Growth & High Prices	2028-2029	Apr	\$6.17	\$6.17	\$6.55	\$6.28	\$6.55	\$6.28	\$6.28	\$6.28	\$6.17	\$6.17	\$6.55	\$6.30	\$6.30	\$6.34
Low Growth & High Prices	2028-2029	May	\$6.27	\$6.27	\$6.55	\$6.39	\$6.55	\$6.39	\$6.39	\$6.39	\$6.27	\$6.27	\$6.55	\$6.36	\$6.36	\$6.42
Low Growth & High Prices	2028-2029	Jun	\$6.26	\$6.26	\$6.55	\$6.38	\$6.55	\$6.38	\$6.38	\$6.38	\$6.26	\$6.26	\$6.55	\$6.36	\$6.36	\$6.41
Low Growth & High Prices	2028-2029	Jul	\$6.38	\$6.38	\$6.55	\$6.49	\$6.55	\$6.49	\$6.49	\$6.49	\$6.38	\$6.38	\$6.55	\$6.44	\$6.44	\$6.51
Low Growth & High Prices	2028-2029	Aug	\$6.37	\$6.37	\$6.56	\$6.49	\$6.56	\$6.49	\$6.49	\$6.49	\$6.37	\$6.37	\$6.56	\$6.43	\$6.43	\$6.50
Low Growth & High Prices	2028-2029	Sep	\$6.35	\$6.35	\$6.56	\$6.46	\$6.56	\$6.46	\$6.46	\$6.46	\$6.35	\$6.35	\$6.56	\$6.42	\$6.42	\$6.48
Low Growth & High Prices	2028-2029	Oct	\$6.40	\$6.40	\$6.95	\$6.51	\$6.95	\$6.51	\$6.51	\$6.51	\$6.40	\$6.40	\$6.95	\$6.58	\$6.58	\$6.60
Low Growth & High Prices	2029-2030	Nov	\$6.84	\$6.84	\$7.00	\$6.97	\$6.99	\$6.97	\$6.97	\$6.97	\$6.84	\$6.84	\$7.00	\$6.89	\$6.89	\$6.97
Low Growth & High Prices	2029-2030	Dec	\$7.10	\$7.19	\$7.10	\$7.32	\$7.32	\$7.32	\$7.32	\$7.32	\$7.10	\$7.19	\$7.10	\$7.13	\$7.13	\$7.32
Low Growth & High Prices	2029-2030	Jan	\$7.10	\$7.24	\$7.10	\$7.37	\$7.37	\$7.37	\$7.37	\$7.37	\$7.10	\$7.24	\$7.10	\$7.15	\$7.15	\$7.37
Low Growth & High Prices	2029-2030	Feb	\$7.10	\$7.13	\$7.10	\$7.26	\$7.18	\$7.16	\$7.16	\$7.16	\$7.10	\$7.13	\$7.10	\$7.11	\$7.11	\$7.18
Low Growth & High Prices	2029-2030	Mar	\$6.99	\$6.99	\$7.00	\$7.12	\$7.12	\$7.12	\$7.12	\$7.12	\$6.99	\$6.99	\$7.00	\$7.00	\$7.00	\$7.12
Low Growth & High Prices	2029-2030	Apr	\$6.57	\$6.57	\$6.97	\$6.69	\$6.97	\$6.69	\$6.69	\$6.69	\$6.57	\$6.57	\$6.97	\$6.70	\$6.70	\$6.75
Low Growth & High Prices	2029-2030	May	\$6.61	\$6.61	\$6.97	\$6.73	\$6.97	\$6.73	\$6.73	\$6.73	\$6.61	\$6.61	\$6.97	\$6.73	\$6.73	\$6.78
Low Growth & High Prices	2029-2030	Jun	\$6.60	\$6.60	\$6.97	\$6.72	\$6.97	\$6.72	\$6.72	\$6.72	\$6.60	\$6.60	\$6.97	\$6.72	\$6.72	\$6.77
Low Growth & High Prices	2029-2030	Jul	\$6.66	\$6.66	\$6.97	\$6.78	\$6.97	\$6.78	\$6.78	\$6.78	\$6.66	\$6.66	\$6.97	\$6.76	\$6.76	\$6.82
Low Growth & High Prices	2029-2030	Aug	\$6.70	\$6.70	\$6.97	\$6.82	\$6.97	\$6.82	\$6.82	\$6.82	\$6.70	\$6.70	\$6.97	\$6.79	\$6.79	\$6.85
Low Growth & High Prices	2029-2030	Sep	\$6.74	\$6.74	\$6.97	\$6.86	\$6.97	\$6.86	\$6.86	\$6.86	\$6.74	\$6.74	\$6.97	\$6.82	\$6.82	\$6.89
Low Growth & High Prices	2029-2030	Oct	\$6.90	\$6.90	\$7.30	\$7.03	\$7.30	\$7.03	\$7.03	\$7.03	\$6.90	\$6.90	\$7.30	\$7.04	\$7.04	\$7.08
Low Growth & High Prices	2030-2031	Nov	\$7.27	\$7.27	\$7.27	\$7.40	\$7.40	\$7.40	\$7.40	\$7.40	\$7.27	\$7.27	\$7.27	\$7.27	\$7.27	\$7.40
Low Growth & High Prices	2030-2031	Dec	\$7.38	\$7.47	\$7.38	\$7.60	\$7.60	\$7.60	\$7.60	\$7.60	\$7.38	\$7.47	\$7.38	\$7.41	\$7.41	\$7.60
Low Growth & High Prices	2030-2031	Jan	\$7.38	\$7.49	\$7.38	\$7.62	\$7.62	\$7.62	\$7.62	\$7.62	\$7.38	\$7.49	\$7.38	\$7.41	\$7.41	\$7.62
Low Growth & High Prices	2030-2031	Feb	\$7.32	\$7.32	\$7.32	\$7.45	\$7.37	\$7.33	\$7.33	\$7.33	\$7.32	\$7.32	\$7.32	\$7.32	\$7.32	\$7.36
Low Growth & High Prices	2030-2031	Mar	\$7.13	\$7.13	\$7.29	\$7.26	\$7.29	\$7.26	\$7.26	\$7.26	\$7.13	\$7.13	\$7.29	\$7.19	\$7.19	\$7.27
Low Growth & High Prices	2030-2031	Apr	\$6.78	\$6.78	\$7.41	\$6.91	\$7.41	\$6.91	\$6.91	\$6.91	\$6.78	\$6.78	\$7.41	\$6.99	\$6.99	\$7.01
Low Growth & High Prices	2030-2031	May	\$6.89	\$6.89	\$7.21	\$7.01	\$7.21	\$7.01	\$7.01	\$7.01	\$6.89	\$6.89	\$7.21	\$6.99	\$6.99	\$7.05
Low Growth & High Prices	2030-2031	Jun	\$6.91	\$6.91	\$7.21	\$7.03	\$7.21	\$7.03	\$7.03	\$7.03	\$6.91	\$6.91	\$7.21	\$7.01	\$7.01	\$7.07
Low Growth & High Prices	2030-2031	Jul	\$6.93	\$6.93	\$7.21	\$7.05	\$7.21	\$7.05	\$7.05	\$7.05	\$6.93	\$6.93	\$7.21	\$7.02	\$7.02	\$7.08
Low Growth & High Prices	2030-2031	Aug	\$6.94	\$6.94	\$7.21	\$7.07	\$7.21	\$7.07	\$7.07	\$7.07	\$6.94	\$6.94	\$7.21	\$7.03	\$7.03	\$7.10
Low Growth & High Prices	2030-2031	Sep	\$6.96	\$6.96	\$7.21	\$7.09	\$7.21	\$7.09	\$7.09	\$7.09	\$6.96	\$6.96	\$7.21	\$7.05	\$7.05	\$7.11
Low Growth & High Prices	2030-2031	Oct	\$7.03	\$7.03	\$7.44	\$7.15	\$7.44	\$7.15	\$7.15	\$7.15	\$7.03	\$7.03	\$7.44	\$7.16	\$7.16	\$7.21
Low Growth & High Prices	2031-2032	Nov	\$7.73	\$7.73	\$7.73	\$7.87	\$7.87	\$7.87	\$7.87	\$7.87	\$7.73	\$7.73	\$7.73	\$7.73	\$7.73	\$7.87
Low Growth & High Prices	2031-2032	Dec	\$7.85	\$7.97	\$7.85	\$8.12	\$8.12	\$8.12	\$8.12	\$8.12	\$7.85	\$7.97	\$7.85	\$7.89	\$7.89	\$8.12
Low Growth & High Prices	2031-2032	Jan	\$7.85	\$7.99	\$7.85	\$8.13	\$8.13	\$8.13	\$8.13	\$8.13	\$7.85	\$7.99	\$7.85	\$7.89	\$7.89	\$8.13
Low Growth & High Prices	2031-2032	Feb	\$7.79	\$7.79	\$7.79	\$7.93	\$7.85	\$7.80	\$7.80	\$7.80	\$7.79	\$7.79	\$7.79	\$7.79	\$7.79	\$7.84
Low Growth & High Prices	2031-2032	Mar	\$7.56	\$7.56	\$7.77	\$7.70	\$7.77	\$7.70	\$7.70	\$7.70	\$7.56	\$7.56	\$7.77	\$7.63	\$7.63	\$7.71
Low Growth & High Prices	2031-2032	Apr	\$7.28	\$7.28	\$7.92	\$7.41	\$7.92	\$7.41	\$7.41	\$7.41	\$7.28	\$7.28	\$7.92	\$7.49	\$7.49	\$7.51
Low Growth & High Prices	2031-2032	May	\$7.32	\$7.32	\$7.59	\$7.46	\$7.59	\$7.46	\$7.46	\$7.46	\$7.32	\$7.32	\$7.59	\$7.41	\$7.41	\$7.48
Low Growth & High Prices	2031-2032	Jun	\$7.29	\$7.29	\$7.60	\$7.43	\$7.60	\$7.43	\$7.43	\$7.43	\$7.29	\$7.29	\$7.60	\$7.39	\$7.39	\$7.46
Low Growth & High Prices	2031-2032	Jul	\$7.16	\$7.16	\$7.60	\$7.29	\$7.60	\$7.29	\$7.29	\$7.29	\$7.16	\$7.16	\$7.60	\$7.30	\$7.30	\$7.35
Low Growth & High Prices	2031-2032	Aug	\$7.18	\$7.18	\$7.60	\$7.31	\$7.60	\$7.31	\$7.31	\$7.31	\$7.18	\$7.18	\$7.60	\$7.32	\$7.32	\$7.37
Low Growth & High Prices	2031-2032	Sep	\$7.35	\$7.35	\$7.60	\$7.48	\$7.60	\$7.48	\$7.48	\$7.48	\$7.35	\$7.35	\$7.60	\$7.43	\$7.43	\$7.51
Low Growth & High Prices	2031-2032	Oct	\$7.48	\$7.48	\$7.92	\$7.62	\$7.92	\$7.62	\$7.62	\$7.62	\$7.48	\$7.48	\$7.92	\$7.63	\$7.63	\$7.68
Low Growth & High Prices	2032-2033	Nov	\$7.96	\$7.96	\$8.17	\$8.11	\$8.17	\$8.11	\$8.11	\$8.11	\$7.96	\$7.96	\$8.17	\$8.03	\$8.03	\$8.12
Low Growth & High Prices	2032-2033	Dec	\$8.29	\$8.40	\$8.29	\$8.55	\$8.55	\$8.55	\$8.55	\$8.55	\$8.29	\$8.40	\$8.29	\$8.33	\$8.33	\$8.55
Low Growth & High Prices	2032-2033	Jan	\$8.29	\$8.57	\$8.29	\$8.73	\$8.73	\$8.73	\$8.73	\$8.73	\$8.29	\$8.57	\$8.29	\$8.38	\$8.38	\$8.73
Low Growth & High Prices	2032-2033	Feb	\$8.28	\$8.28	\$8.28	\$8.43	\$8.34	\$8.34	\$8.34	\$8.34	\$8.28	\$8.28	\$8.28	\$8.28	\$8.28	\$8.36
Low Growth & High Prices	2032-2033	Mar	\$8.17	\$8.17	\$8.18	\$8.32	\$8.32	\$8.32	\$8.32	\$8.32	\$8.17	\$8.17	\$8.18	\$8.18	\$8.18	\$8.32
Low Growth & High Prices	2032-2033	Apr	\$7.78	\$7.78	\$8.40	\$7.92	\$8.40	\$7.92	\$7.92	\$7.92	\$7.78	\$7.78	\$8.40	\$7.99	\$7.99	\$8.02
Low Growth & High Prices	2032-2033	May	\$7.84	\$7.84	\$8.16	\$7.98	\$8.16	\$7.98	\$7.98	\$7.98	\$7.84	\$7.84	\$8.16	\$7.94	\$7.94	\$8.01
Low Growth & High Prices	2032-2033	Jun	\$7.86	\$7.86	\$8.16	\$8.00	\$8.16	\$8.00	\$8.00	\$8.00	\$7.86	\$7.86	\$8.16	\$7.96	\$7.96	\$8.03
Low Growth & High Prices	2032-2033	Jul	\$7.76	\$7.76	\$8.16	\$7.90	\$8.16	\$7.90	\$7.90	\$7.90	\$7.76	\$7.76	\$8.16	\$7.89	\$7.89	\$7.95
Low Growth & High Prices	2032-2033	Aug	\$7.84	\$7.84	\$8.16	\$7.99	\$8.16	\$7.99	\$7.99	\$7.99	\$7.84	\$7.84	\$8.16	\$7.95	\$7.95	\$8.02
Low Growth & High Prices	2032-2033	Sep	\$7.92	\$7.92	\$8.16	\$8.06	\$8.16	\$8.06	\$8.06	\$8.06	\$7.92	\$7.92	\$8.16	\$8.00	\$8.00	\$8.08
Low Growth & High Prices	2032-2033	Oct	\$8.05	\$8.05	\$8.49	\$8.19	\$8.49	\$8.19	\$8.19	\$8.19	\$8.05	\$8.05	\$8.49	\$8.20	\$8.20	\$8.25
Low Growth & High Prices	2033-2034	Nov	\$8.67	\$8.67	\$8.80	\$8.82	\$8.82	\$8.82	\$8.82	\$8.82	\$8.67	\$8.67	\$8.80	\$8.71	\$8.71	\$8.82
Low Growth & High Prices	2033-2034	Dec	\$8.85	\$8.85	\$8.85	\$9.01	\$9.01	\$9.01	\$9.01	\$9.01	\$8.85	\$8.85	\$8.85	\$8.85	\$8.85	\$9.01
Low Growth & High Prices	2033-2034	Jan	\$8.93	\$8.97	\$8.93	\$9.13	\$9.13	\$9.13	\$9.13	\$9.13	\$8.93	\$8.97	\$8.93	\$8.94	\$8.94	\$9.13
Low Growth & High Prices	2033-2034	Feb	\$8.80	\$8.80	\$8.80	\$8.96	\$8.87	\$8.79	\$8.79	\$8.79	\$8.80	\$8.80	\$8.80			

			Monthly Avoided Costs ¹															
			Nominal \$															
Scenario	Gas Year	Month	ID Both	ID GTN	ID NWP	Klamath Falls	La Grande	Medford GTN	Medford NWP	Roseburg	WA Both	WA GTN	WA NWP	Idaho	Washington	Oregon		
Low Growth & High Prices	2035-2036	Jan	\$9.73	\$9.98	\$9.73	\$10.16	\$10.16	\$10.16	\$10.16	\$10.16	\$9.73	\$9.98	\$9.73	\$9.82	\$9.82	\$10.16		
Low Growth & High Prices	2035-2036	Feb	\$9.67	\$9.67	\$9.67	\$9.85	\$9.75	\$9.64	\$9.64	\$9.64	\$9.67	\$9.67	\$9.67	\$9.67	\$9.67	\$9.70		
Low Growth & High Prices	2035-2036	Mar	\$9.31	\$9.31	\$9.67	\$9.48	\$9.67	\$9.48	\$9.48	\$9.48	\$9.31	\$9.31	\$9.67	\$9.43	\$9.43	\$9.52		
Low Growth & High Prices	2035-2036	Apr	\$8.96	\$8.96	\$9.47	\$9.12	\$9.47	\$9.12	\$9.12	\$9.12	\$8.96	\$8.96	\$9.47	\$9.13	\$9.13	\$9.19		
Low Growth & High Prices	2035-2036	May	\$8.97	\$8.97	\$9.34	\$9.13	\$9.34	\$9.13	\$9.13	\$9.13	\$8.97	\$8.97	\$9.34	\$9.09	\$9.09	\$9.17		
Low Growth & High Prices	2035-2036	Jun	\$9.04	\$9.04	\$9.34	\$9.20	\$9.34	\$9.20	\$9.20	\$9.20	\$9.04	\$9.04	\$9.34	\$9.14	\$9.14	\$9.23		
Low Growth & High Prices	2035-2036	Jul	\$9.02	\$9.02	\$9.34	\$9.18	\$9.34	\$9.18	\$9.18	\$9.18	\$9.02	\$9.02	\$9.34	\$9.13	\$9.13	\$9.21		
Low Growth & High Prices	2035-2036	Aug	\$9.04	\$9.04	\$9.34	\$9.20	\$9.34	\$9.20	\$9.20	\$9.20	\$9.04	\$9.04	\$9.34	\$9.14	\$9.14	\$9.23		
Low Growth & High Prices	2035-2036	Sep	\$9.11	\$9.11	\$9.34	\$9.27	\$9.34	\$9.27	\$9.27	\$9.27	\$9.11	\$9.11	\$9.34	\$9.19	\$9.19	\$9.29		
Low Growth & High Prices	2035-2036	Oct	\$9.27	\$9.27	\$9.69	\$9.44	\$9.69	\$9.44	\$9.44	\$9.44	\$9.27	\$9.27	\$9.69	\$9.41	\$9.41	\$9.49		
Low Growth & High Prices	2036-2037	Nov	\$9.76	\$9.76	\$9.78	\$9.93	\$9.93	\$9.93	\$9.93	\$9.93	\$9.76	\$9.76	\$9.78	\$9.76	\$9.76	\$9.93		
Low Growth & High Prices	2036-2037	Dec	\$9.92	\$10.23	\$9.92	\$10.41	\$10.41	\$10.41	\$10.41	\$10.41	\$9.92	\$10.23	\$9.92	\$10.02	\$10.02	\$10.41		
Low Growth & High Prices	2036-2037	Jan	\$9.92	\$10.44	\$9.92	\$10.63	\$10.63	\$10.63	\$10.63	\$10.63	\$9.92	\$10.44	\$9.92	\$10.09	\$10.09	\$10.63		
Low Growth & High Prices	2036-2037	Feb	\$9.95	\$10.22	\$9.95	\$10.40	\$10.29	\$10.02	\$10.02	\$10.02	\$9.95	\$10.22	\$9.95	\$10.04	\$10.04	\$10.15		
Low Growth & High Prices	2036-2037	Mar	\$9.64	\$9.64	\$9.69	\$9.81	\$9.81	\$9.81	\$9.81	\$9.81	\$9.64	\$9.64	\$9.69	\$9.65	\$9.65	\$9.81		
Low Growth & High Prices	2036-2037	Apr	\$9.23	\$9.23	\$9.75	\$9.39	\$9.75	\$9.39	\$9.39	\$9.39	\$9.23	\$9.23	\$9.75	\$9.40	\$9.40	\$9.46		
Low Growth & High Prices	2036-2037	May	\$9.41	\$9.41	\$9.69	\$9.58	\$9.69	\$9.58	\$9.58	\$9.58	\$9.41	\$9.41	\$9.69	\$9.51	\$9.51	\$9.60		
Low Growth & High Prices	2036-2037	Jun	\$9.38	\$9.38	\$9.70	\$9.55	\$9.70	\$9.55	\$9.55	\$9.55	\$9.38	\$9.38	\$9.70	\$9.48	\$9.48	\$9.58		
Low Growth & High Prices	2036-2037	Jul	\$9.38	\$9.38	\$9.70	\$9.54	\$9.70	\$9.54	\$9.54	\$9.54	\$9.38	\$9.38	\$9.70	\$9.48	\$9.48	\$9.57		
Low Growth & High Prices	2036-2037	Aug	\$9.50	\$9.50	\$9.70	\$9.67	\$9.70	\$9.67	\$9.67	\$9.67	\$9.50	\$9.50	\$9.70	\$9.57	\$9.57	\$9.68		
Low Growth & High Prices	2036-2037	Sep	\$9.48	\$9.48	\$9.70	\$9.64	\$9.70	\$9.64	\$9.64	\$9.64	\$9.48	\$9.48	\$9.70	\$9.55	\$9.55	\$9.66		
Low Growth & High Prices	2036-2037	Oct	\$9.59	\$9.59	\$10.01	\$9.76	\$10.01	\$9.76	\$9.76	\$9.76	\$9.59	\$9.59	\$10.01	\$9.73	\$9.73	\$9.81		
Low Growth & High Prices	2037-2038	Nov	\$10.34	\$10.51	\$10.34	\$10.70	\$10.70	\$10.70	\$10.70	\$10.70	\$10.34	\$10.51	\$10.34	\$10.40	\$10.40	\$10.70		
Low Growth & High Prices	2037-2038	Dec	\$10.38	\$10.97	\$10.38	\$11.16	\$11.16	\$11.16	\$11.16	\$11.16	\$10.38	\$10.97	\$10.38	\$10.58	\$10.58	\$11.16		
Low Growth & High Prices	2037-2038	Jan	\$10.39	\$11.03	\$10.39	\$11.23	\$11.23	\$11.23	\$11.23	\$11.23	\$10.39	\$11.03	\$10.39	\$10.60	\$10.60	\$11.23		
Low Growth & High Prices	2037-2038	Feb	\$10.24	\$10.24	\$10.24	\$10.42	\$10.31	\$10.13	\$10.13	\$10.13	\$10.24	\$10.24	\$10.24	\$10.24	\$10.24	\$10.22		
Low Growth & High Prices	2037-2038	Mar	\$9.74	\$9.74	\$10.33	\$9.91	\$10.33	\$9.91	\$9.91	\$9.91	\$9.74	\$9.74	\$10.33	\$9.94	\$9.94	\$10.00		
Low Growth & High Prices	2037-2038	Apr	\$9.50	\$9.50	\$10.00	\$9.67	\$10.00	\$9.67	\$9.67	\$9.67	\$9.50	\$9.50	\$10.00	\$9.66	\$9.66	\$9.73		
Low Growth & High Prices	2037-2038	May	\$9.68	\$9.68	\$9.95	\$9.85	\$9.95	\$9.85	\$9.85	\$9.85	\$9.68	\$9.68	\$9.95	\$9.77	\$9.77	\$9.87		
Low Growth & High Prices	2037-2038	Jun	\$9.69	\$9.69	\$9.95	\$9.86	\$9.95	\$9.86	\$9.86	\$9.86	\$9.69	\$9.69	\$9.95	\$9.77	\$9.77	\$9.87		
Low Growth & High Prices	2037-2038	Jul	\$9.68	\$9.68	\$9.95	\$9.85	\$9.95	\$9.85	\$9.85	\$9.85	\$9.68	\$9.68	\$9.95	\$9.77	\$9.77	\$9.87		
Low Growth & High Prices	2037-2038	Aug	\$9.72	\$9.72	\$9.95	\$9.90	\$9.95	\$9.89	\$9.89	\$9.89	\$9.72	\$9.72	\$9.95	\$9.80	\$9.80	\$9.90		
Low Growth & High Prices	2037-2038	Sep	\$9.78	\$9.78	\$9.95	\$9.95	\$9.95	\$9.95	\$9.95	\$9.95	\$9.78	\$9.78	\$9.95	\$9.83	\$9.83	\$9.95		
Low Growth & High Prices	2037-2038	Oct	\$9.90	\$9.90	\$10.31	\$10.08	\$10.31	\$10.08	\$10.08	\$10.08	\$9.90	\$9.90	\$10.31	\$10.04	\$10.04	\$10.13		
Low Growth & High Prices	2038-2039	Nov	\$10.80	\$10.80	\$10.92	\$10.99	\$10.99	\$10.99	\$10.99	\$10.99	\$10.80	\$10.80	\$10.92	\$10.84	\$10.84	\$10.99		
Low Growth & High Prices	2038-2039	Dec	\$11.08	\$11.41	\$11.08	\$11.62	\$11.62	\$11.62	\$11.62	\$11.62	\$11.08	\$11.41	\$11.08	\$11.19	\$11.19	\$11.62		
Low Growth & High Prices	2038-2039	Jan	\$11.08	\$11.54	\$11.08	\$11.75	\$11.75	\$11.75	\$11.75	\$11.75	\$11.08	\$11.54	\$11.08	\$11.24	\$11.24	\$11.75		
Low Growth & High Prices	2038-2039	Feb	\$11.09	\$11.16	\$11.09	\$11.35	\$11.24	\$11.19	\$11.19	\$11.19	\$11.09	\$11.16	\$11.09	\$11.11	\$11.11	\$11.23		
Low Growth & High Prices	2038-2039	Mar	\$10.90	\$10.90	\$10.91	\$11.09	\$11.09	\$11.09	\$11.09	\$11.09	\$10.90	\$10.90	\$10.91	\$10.90	\$10.90	\$11.09		
Low Growth & High Prices	2038-2039	Apr	\$10.45	\$10.45	\$10.93	\$10.63	\$10.93	\$10.63	\$10.63	\$10.63	\$10.45	\$10.45	\$10.93	\$10.61	\$10.61	\$10.69		
Low Growth & High Prices	2038-2039	May	\$10.49	\$10.49	\$10.89	\$10.68	\$10.89	\$10.68	\$10.68	\$10.68	\$10.49	\$10.49	\$10.89	\$10.62	\$10.62	\$10.72		
Low Growth & High Prices	2038-2039	Jun	\$10.45	\$10.45	\$10.89	\$10.63	\$10.89	\$10.63	\$10.63	\$10.63	\$10.45	\$10.45	\$10.89	\$10.60	\$10.60	\$10.69		
Low Growth & High Prices	2038-2039	Jul	\$10.55	\$10.55	\$10.89	\$10.74	\$10.89	\$10.72	\$10.72	\$10.72	\$10.55	\$10.55	\$10.89	\$10.66	\$10.66	\$10.76		
Low Growth & High Prices	2038-2039	Aug	\$10.55	\$10.55	\$10.89	\$10.74	\$10.89	\$10.72	\$10.72	\$10.72	\$10.55	\$10.55	\$10.89	\$10.66	\$10.66	\$10.76		
Low Growth & High Prices	2038-2039	Sep	\$10.72	\$10.72	\$10.89	\$10.91	\$10.89	\$10.89	\$10.89	\$10.89	\$10.72	\$10.72	\$10.89	\$10.78	\$10.78	\$10.90		
Low Growth & High Prices	2038-2039	Oct	\$10.78	\$10.78	\$11.22	\$10.97	\$11.22	\$10.97	\$10.97	\$10.97	\$10.78	\$10.78	\$11.22	\$10.92	\$10.92	\$11.02		
Low Growth & High Prices	2039-2040	Nov	\$11.99	\$11.99	\$11.99	\$12.20	\$12.20	\$12.20	\$12.20	\$12.20	\$11.99	\$11.99	\$11.99	\$11.99	\$11.99	\$12.20		
Low Growth & High Prices	2039-2040	Dec	\$12.16	\$12.31	\$12.16	\$12.53	\$12.53	\$12.53	\$12.53	\$12.53	\$12.16	\$12.31	\$12.16	\$12.21	\$12.21	\$12.53		
Low Growth & High Prices	2039-2040	Jan	\$12.16	\$12.36	\$12.16	\$12.57	\$12.57	\$12.57	\$12.57	\$12.57	\$12.16	\$12.36	\$12.16	\$12.23	\$12.23	\$12.57		
Low Growth & High Prices	2039-2040	Feb	\$12.10	\$12.10	\$12.10	\$12.31	\$12.19	\$12.10	\$12.10	\$12.10	\$12.10	\$12.10	\$12.10	\$12.10	\$12.10	\$12.16		
Low Growth & High Prices	2039-2040	Mar	\$11.70	\$11.70	\$12.09	\$11.90	\$12.09	\$11.90	\$11.90	\$11.90	\$11.70	\$11.70	\$12.09	\$11.83	\$11.83	\$11.94		
Low Growth & High Prices	2039-2040	Apr	\$11.31	\$11.31	\$11.80	\$11.51	\$11.80	\$11.51	\$11.51	\$11.51	\$11.31	\$11.31	\$11.80	\$11.47	\$11.47	\$11.57		
Low Growth & High Prices	2039-2040	May	\$11.38	\$11.38	\$11.66	\$11.58	\$11.66	\$11.56	\$11.56	\$11.56	\$11.38	\$11.38	\$11.66	\$11.47	\$11.47	\$11.58		
Low Growth & High Prices	2039-2040	Jun	\$11.35	\$11.35	\$11.66	\$11.55	\$11.66	\$11.52	\$11.52	\$11.52	\$11.35	\$11.35	\$11.66	\$11.45	\$11.45	\$11.55		
Low Growth & High Prices	2039-2040	Jul	\$11.36	\$11.36	\$11.66	\$11.56	\$11.66	\$11.52	\$11.52	\$11.52	\$11.36	\$11.36	\$11.66	\$11.46	\$11.46	\$11.56		
Low Growth & High Prices	2039-2040	Aug	\$11.36	\$11.36	\$11.66	\$11.56	\$11.66	\$11.52	\$11.52	\$11.52	\$11.36	\$11.36	\$11.66	\$11.46	\$11.46	\$11.56		
Low Growth & High Prices	2039-2040	Sep	\$11.49	\$11.49	\$11.66	\$11.70	\$11.66	\$11.66	\$11.66	\$11.66	\$11.49	\$11.49	\$11.66	\$11.55	\$11.55	\$11.67		
Low Growth & High Prices	2039-2040	Oct	\$11.61	\$11.61	\$12.06	\$11.81	\$12.06	\$11.81	\$11.81	\$11.81	\$11.61	\$11.61	\$12.06	\$11.76	\$11.76	\$11.86		

¹Avoided costs are before Environmental Externalities adder

APPENDIX 6.4: EXPECTED CASE MONTHLY DETAIL

Scenario	Gas Year	Month	Monthly Avoided Costs ²													
			Nominal \$													
			ID Both	ID GTN	ID NWP	Klamath Falls	La Grande	Medford GTN	Medford NWP	Roseburg	WA Both	WA GTN	WA NWP	Idaho	Washington	Oregon
Expected Case	2019-2020	Nov	\$2.00	\$2.18	\$2.00	\$2.22	\$2.22	\$2.22	\$2.22	\$2.22	\$2.00	\$2.18	\$2.00	\$2.06	\$2.06	\$2.22
Expected Case	2019-2020	Dec	\$1.99	\$1.87	\$1.99	\$2.17	\$2.25	\$2.17	\$2.17	\$1.84	\$1.99	\$1.87	\$1.99	\$1.95	\$1.95	\$2.19
Expected Case	2019-2020	Jan	\$2.00	\$1.80	\$2.00	\$1.84	\$2.02	\$2.17	\$1.84	\$1.84	\$2.00	\$1.87	\$2.00	\$1.93	\$1.93	\$1.88
Expected Case	2019-2020	Feb	\$1.95	\$1.43	\$1.97	\$1.50	\$1.97	\$1.50	\$1.50	\$1.50	\$1.95	\$1.43	\$1.97	\$1.79	\$1.79	\$1.60
Expected Case	2019-2020	Mar	\$1.25	\$1.25	\$1.38	\$1.28	\$1.38	\$1.28	\$1.28	\$1.28	\$1.25	\$1.25	\$1.38	\$1.30	\$1.30	\$1.30
Expected Case	2019-2020	Apr	\$1.03	\$1.03	\$1.15	\$1.05	\$1.14	\$1.15	\$1.15	\$1.15	\$1.03	\$1.03	\$1.15	\$1.07	\$1.07	\$1.13
Expected Case	2019-2020	May	\$1.05	\$1.14	\$1.05	\$1.07	\$1.05	\$1.05	\$1.05	\$1.05	\$1.05	\$1.14	\$1.05	\$1.08	\$1.08	\$1.06
Expected Case	2019-2020	Jun	\$0.90	\$0.90	\$1.06	\$0.86	\$0.90	\$0.86	\$0.86	\$0.86	\$0.90	\$0.90	\$1.06	\$0.95	\$0.95	\$0.87
Expected Case	2019-2020	Jul	\$0.86	\$0.86	\$1.06	\$0.80	\$0.90	\$0.80	\$0.80	\$0.80	\$0.86	\$0.86	\$1.06	\$0.93	\$0.93	\$0.82
Expected Case	2019-2020	Aug	\$1.10	\$1.10	\$1.11	\$1.13	\$1.11	\$1.11	\$1.11	\$1.11	\$1.10	\$1.10	\$1.11	\$1.11	\$1.11	\$1.12
Expected Case	2019-2020	Sep	\$0.99	\$0.99	\$1.06	\$1.01	\$1.06	\$1.01	\$1.01	\$1.01	\$0.99	\$0.99	\$1.06	\$1.01	\$1.01	\$1.02
Expected Case	2019-2020	Oct	\$1.02	\$1.02	\$1.31	\$1.04	\$1.31	\$1.04	\$1.04	\$1.04	\$1.02	\$1.02	\$1.31	\$1.12	\$1.12	\$1.10
Expected Case	2020-2021	Nov	\$1.81	\$1.81	\$1.82	\$1.74	\$1.82	\$1.74	\$1.74	\$1.74	\$1.81	\$1.81	\$1.82	\$1.81	\$1.81	\$1.75
Expected Case	2020-2021	Dec	\$2.44	\$2.36	\$2.44	\$2.46	\$2.46	\$2.46	\$2.46	\$2.46	\$2.44	\$2.36	\$2.44	\$2.42	\$2.42	\$2.46
Expected Case	2020-2021	Jan	\$2.45	\$2.45	\$2.45	\$2.50	\$2.52	\$2.50	\$2.50	\$2.50	\$2.45	\$2.45	\$2.45	\$2.45	\$2.45	\$2.51
Expected Case	2020-2021	Feb	\$2.47	\$2.33	\$2.47	\$2.41	\$2.47	\$2.41	\$2.41	\$2.41	\$2.47	\$2.33	\$2.47	\$2.42	\$2.42	\$2.42
Expected Case	2020-2021	Mar	\$2.02	\$2.02	\$2.31	\$2.06	\$2.31	\$2.06	\$2.06	\$2.02	\$2.02	\$2.31	\$2.12	\$2.12	\$2.12	\$2.11
Expected Case	2020-2021	Apr	\$1.51	\$1.51	\$1.87	\$1.54	\$1.87	\$1.85	\$1.85	\$1.85	\$1.51	\$1.51	\$1.87	\$1.63	\$1.63	\$1.79
Expected Case	2020-2021	May	\$1.40	\$1.40	\$1.87	\$1.43	\$1.83	\$1.43	\$1.43	\$1.43	\$1.40	\$1.40	\$1.87	\$1.56	\$1.56	\$1.51
Expected Case	2020-2021	Jun	\$1.45	\$1.45	\$1.87	\$1.48	\$1.82	\$1.48	\$1.48	\$1.48	\$1.45	\$1.45	\$1.87	\$1.59	\$1.59	\$1.55
Expected Case	2020-2021	Jul	\$1.58	\$1.58	\$1.87	\$1.62	\$1.87	\$1.62	\$1.62	\$1.58	\$1.58	\$1.87	\$1.68	\$1.68	\$1.67	\$1.67
Expected Case	2020-2021	Aug	\$1.57	\$1.57	\$1.87	\$1.61	\$1.87	\$1.61	\$1.61	\$1.57	\$1.57	\$1.87	\$1.67	\$1.67	\$1.66	\$1.66
Expected Case	2020-2021	Sep	\$1.42	\$1.42	\$1.87	\$1.45	\$1.87	\$1.45	\$1.45	\$1.45	\$1.42	\$1.42	\$1.87	\$1.57	\$1.57	\$1.54
Expected Case	2020-2021	Oct	\$1.45	\$1.45	\$2.05	\$1.48	\$2.05	\$1.48	\$1.48	\$1.48	\$1.45	\$1.45	\$2.05	\$1.65	\$1.65	\$1.60
Expected Case	2021-2022	Nov	\$1.79	\$1.79	\$2.15	\$1.83	\$2.15	\$1.83	\$1.83	\$1.83	\$1.79	\$2.15	\$1.91	\$1.91	\$1.91	\$1.90
Expected Case	2021-2022	Dec	\$2.11	\$2.08	\$2.16	\$2.18	\$2.21	\$2.18	\$2.18	\$2.18	\$2.11	\$2.08	\$2.16	\$2.12	\$2.12	\$2.18
Expected Case	2021-2022	Jan	\$2.19	\$2.19	\$2.19	\$2.24	\$2.24	\$2.24	\$2.24	\$2.24	\$2.19	\$2.19	\$2.19	\$2.19	\$2.19	\$2.24
Expected Case	2021-2022	Feb	\$2.10	\$2.05	\$2.20	\$2.13	\$2.20	\$2.13	\$2.13	\$2.13	\$2.10	\$2.05	\$2.20	\$2.11	\$2.11	\$2.15
Expected Case	2021-2022	Mar	\$1.74	\$1.74	\$2.15	\$1.77	\$2.15	\$1.77	\$1.77	\$1.74	\$1.74	\$2.15	\$1.87	\$1.87	\$1.87	\$1.85
Expected Case	2021-2022	Apr	\$1.11	\$1.11	\$1.69	\$1.13	\$1.69	\$1.62	\$1.62	\$1.11	\$1.11	\$1.69	\$1.30	\$1.30	\$1.53	\$1.53
Expected Case	2021-2022	May	\$1.08	\$1.08	\$1.69	\$1.11	\$1.68	\$1.11	\$1.11	\$1.11	\$1.08	\$1.08	\$1.69	\$1.28	\$1.28	\$1.22
Expected Case	2021-2022	Jun	\$1.18	\$1.18	\$1.69	\$1.21	\$1.69	\$1.21	\$1.21	\$1.18	\$1.18	\$1.69	\$1.35	\$1.35	\$1.31	\$1.31
Expected Case	2021-2022	Jul	\$1.34	\$1.34	\$1.69	\$1.37	\$1.69	\$1.37	\$1.37	\$1.34	\$1.34	\$1.69	\$1.45	\$1.45	\$1.43	\$1.43
Expected Case	2021-2022	Aug	\$1.29	\$1.29	\$1.69	\$1.32	\$1.69	\$1.32	\$1.32	\$1.29	\$1.29	\$1.69	\$1.42	\$1.42	\$1.39	\$1.39
Expected Case	2021-2022	Sep	\$1.11	\$1.11	\$1.69	\$1.13	\$1.69	\$1.13	\$1.13	\$1.11	\$1.11	\$1.69	\$1.30	\$1.30	\$1.24	\$1.24
Expected Case	2021-2022	Oct	\$1.11	\$1.11	\$1.69	\$1.13	\$1.69	\$1.13	\$1.13	\$1.11	\$1.11	\$1.69	\$1.30	\$1.30	\$1.24	\$1.24
Expected Case	2022-2023	Nov	\$1.38	\$1.38	\$1.96	\$1.41	\$1.96	\$1.41	\$1.41	\$1.38	\$1.38	\$1.96	\$1.57	\$1.57	\$1.52	\$1.52
Expected Case	2022-2023	Dec	\$1.92	\$1.89	\$1.97	\$1.99	\$2.03	\$1.99	\$1.99	\$1.92	\$1.89	\$1.97	\$1.93	\$1.93	\$2.00	\$2.00
Expected Case	2022-2023	Jan	\$2.00	\$2.00	\$2.00	\$2.04	\$2.04	\$2.04	\$2.04	\$2.00	\$2.00	\$2.00	\$2.00	\$2.00	\$2.00	\$2.04
Expected Case	2022-2023	Feb	\$1.85	\$1.79	\$2.00	\$1.88	\$2.00	\$1.88	\$1.88	\$1.85	\$1.79	\$2.00	\$1.88	\$1.88	\$1.91	\$1.91
Expected Case	2022-2023	Mar	\$1.53	\$1.53	\$1.94	\$1.56	\$1.94	\$1.56	\$1.56	\$1.53	\$1.53	\$1.94	\$1.66	\$1.66	\$1.64	\$1.64
Expected Case	2022-2023	Apr	\$1.07	\$1.07	\$1.67	\$1.09	\$1.67	\$1.61	\$1.61	\$1.07	\$1.07	\$1.67	\$1.27	\$1.27	\$1.52	\$1.52
Expected Case	2022-2023	May	\$1.03	\$1.03	\$1.67	\$1.06	\$1.63	\$1.06	\$1.06	\$1.03	\$1.03	\$1.67	\$1.25	\$1.25	\$1.17	\$1.17
Expected Case	2022-2023	Jun	\$1.21	\$1.21	\$1.67	\$1.23	\$1.66	\$1.23	\$1.23	\$1.21	\$1.21	\$1.67	\$1.36	\$1.36	\$1.32	\$1.32
Expected Case	2022-2023	Jul	\$1.26	\$1.26	\$1.67	\$1.29	\$1.67	\$1.29	\$1.29	\$1.26	\$1.26	\$1.67	\$1.40	\$1.40	\$1.37	\$1.37
Expected Case	2022-2023	Aug	\$1.27	\$1.27	\$1.67	\$1.30	\$1.67	\$1.30	\$1.30	\$1.27	\$1.27	\$1.67	\$1.40	\$1.40	\$1.37	\$1.37
Expected Case	2022-2023	Sep	\$0.99	\$0.99	\$1.68	\$1.01	\$1.68	\$1.01	\$1.01	\$0.99	\$0.99	\$1.68	\$1.22	\$1.22	\$1.14	\$1.14
Expected Case	2022-2023	Oct	\$1.07	\$1.07	\$1.72	\$1.10	\$1.72	\$1.10	\$1.10	\$1.07	\$1.07	\$1.72	\$1.29	\$1.29	\$1.22	\$1.22
Expected Case	2023-2024	Nov	\$1.60	\$1.60	\$2.03	\$1.63	\$2.03	\$1.63	\$1.63	\$1.60	\$1.60	\$2.03	\$1.74	\$1.74	\$1.71	\$1.71
Expected Case	2023-2024	Dec	\$1.92	\$1.85	\$2.03	\$1.98	\$2.08	\$1.98	\$1.98	\$1.92	\$1.85	\$2.03	\$1.93	\$1.93	\$2.00	\$2.00
Expected Case	2023-2024	Jan	\$2.06	\$2.06	\$2.06	\$2.11	\$2.12	\$2.11	\$2.11	\$2.11	\$2.06	\$2.06	\$2.06	\$2.06	\$2.06	\$2.11
Expected Case	2023-2024	Feb	\$1.83	\$1.76	\$2.06	\$1.81	\$2.07	\$1.81	\$1.81	\$1.83	\$1.76	\$2.06	\$1.88	\$1.88	\$1.86	\$1.86
Expected Case	2023-2024	Mar	\$1.69	\$1.69	\$2.00	\$1.72	\$2.00	\$1.72	\$1.72	\$1.69	\$1.69	\$2.00	\$1.79	\$1.79	\$1.78	\$1.78
Expected Case	2023-2024	Apr	\$1.38	\$1.38	\$1.73	\$1.41	\$1.73	\$1.73	\$1.73	\$1.38	\$1.38	\$1.73	\$1.49	\$1.49	\$1.66	\$1.66
Expected Case	2023-2024	May	\$1.36	\$1.36	\$1.70	\$1.40	\$1.70	\$1.40	\$1.40	\$1.36	\$1.36	\$1.70	\$1.48	\$1.48	\$1.46	\$1.46
Expected Case	2023-2024	Jun	\$1.38	\$1.38	\$1.70	\$1.41	\$1.70	\$1.41	\$1.41	\$1.38	\$1.38	\$1.70	\$1.49	\$1.49	\$1.47	\$1.47
Expected Case	2023-2024	Jul	\$1.35	\$1.35	\$1.70	\$1.38	\$1.70	\$1.38	\$1.38	\$1.35	\$1.35	\$1.70	\$1.47	\$1.47	\$1.45	\$1.45
Expected Case	2023-2024	Aug	\$1.36	\$1.36	\$1.70	\$1.39	\$1.70	\$1.39	\$1.39	\$1.36	\$1.36	\$1.70	\$1.47	\$1.47	\$1.45	\$1.45
Expected Case	2023-2024	Sep	\$1.44	\$1.44	\$1.70	\$1.47	\$1.70	\$1.47	\$1.47	\$1.44	\$1.44	\$1.70	\$1.53	\$1.53	\$1.52	\$1.52
Expected Case	2023-2024	Oct	\$1.45	\$1.45	\$1.76	\$1.48	\$1.76	\$1.48	\$1.48	\$1.45	\$1.45	\$1.76	\$1.56	\$1.56	\$1.54	\$1.54
Expected Case	2024-2025	Nov	\$1.60	\$1.60	\$2.07	\$1.63	\$2.07	\$1.63	\$1.63	\$1.60	\$1.60	\$2.07	\$1.76	\$1.76	\$1.72	\$1.72
Expected Case	2024-2025	Dec	\$1.99	\$1.84	\$2.08	\$2.01	\$2.16	\$2.01	\$2.01	\$1.99	\$1.84	\$2.08	\$1.97	\$1.97	\$2.04	\$2.04
Expected Case	2024-2025	Jan	\$2.11	\$2.11	\$2.11	\$2.15	\$2.17	\$2.15	\$2.15	\$2.11	\$2.11	\$2.11	\$2.11	\$2.11	\$2.11	\$2.16
Expected Case	2024-2025	Feb	\$2.02	\$1.99	\$2.09	\$2.07	\$2.14	\$2.07	\$2.07	\$2.02	\$1.99	\$2.09	\$2.04	\$2.04	\$2.08	\$2.08
Expected Case	2024-2025	Mar	\$1.86	\$1.86	\$2.03	\$1.90	\$2.03	\$1.90	\$1.90	\$1.86	\$1.86	\$2.03	\$1.92	\$1.92	\$1.93	\$1.93
Expected Case	2024-2025	Apr	\$1.68	\$1.68	\$2.11	\$1.72	\$2.11	\$2.11	\$2.11	\$1.68	\$1.68	\$2.11	\$1.82	\$1.82	\$2.03	\$2.03
Expected Case	2024-2025	May	\$1.77	\$1.77	\$2.03	\$1.80	\$2.03	\$1.80	\$1.80	\$1.77	\$1.77	\$2.03	\$1.85	\$1.85	\$1.85	\$1.85
Expected Case	2024-2025	Jun	\$1.69	\$1.69	\$2.03	\$1.73	\$2.03	\$1.73	\$1.73	\$1.69	\$1.69	\$2.03	\$1.80	\$1.80	\$1.79	\$1.79
Expected Case	2024-2025	Jul	\$1.70	\$1.70	\$2.03	\$1.74	\$2.03	\$1.74	\$1.74	\$1.70	\$1.70	\$2.03	\$1.81	\$1.81	\$1.80	\$1.80
Expected Case	2024-2025	Aug	\$1.70	\$1.70	\$2.03	\$1.73	\$2.03	\$1.73	\$1.73	\$1.70	\$1.70	\$2.03	\$1.81	\$1.81	\$1.79	\$1.79
Expected Case	2024-2025	Sep	\$1.79	\$1.79	\$2.03	\$1.82	\$2.03	\$1.82	\$1.82	\$1.79	\$1.79	\$2.03	\$1.87	\$1.87	\$1.87	\$1.87
Expected Case	2024-2025	Oct	\$1.79	\$1.79	\$2.38	\$1.82	\$2.38	\$1.82	\$1.82	\$1.79	\$1.79	\$2.38	\$1.98	\$1.98	\$1.93	\$1.93
Expected Case	2025-2026	Nov	\$2.01	\$2.01	\$2.46	\$2.05	\$2.46	\$2.05	\$2.05	\$2.01	\$2.01	\$2.46	\$2.16	\$2.16	\$2.14	\$2.14
Expected Case	2025-2026	Dec	\$2.36	\$2.17	\$2.47	\$2.38	\$2.55	\$2.38	\$2.38	\$2.36	\$2.17	\$2.47	\$2.33	\$2.33	\$2.41	\$2.41
Expected Case	2025-2026	Jan	\$2.50	\$2.50	\$2.50	\$2.56	\$2.58	\$2.56	\$2.56	\$2.56	\$2.50	\$2.50	\$2.50	\$2.50	\$2.50	\$2.56
Expected Case	2025-2026	Feb	\$2.48	\$2.44	\$2.50	\$2.53	\$2.56	\$2.53	\$2.53	\$2.48	\$2.44	\$2.50	\$2.47	\$2.47	\$2.54	\$2.54
Expected Case	2025-2026	Mar	\$2.30	\$2.30	\$2.39	\$2.35	\$2.39	\$2.35	\$2.35	\$2.30	\$2.30	\$2.39	\$2.33	\$2.33	\$2.	

Monthly Avoided Costs ¹																
Nominal \$																
Scenario	Gas Year	Month	ID Both	IDGTN	IDNWP	Klamath Falls	La Grande	Medford GTN	Medford NWP	Roseburg	WA Both	WA GTN	WA NWP	Idaho	Washington	Oregon
Expected Case	2027-2028	Dec	\$2.81	\$2.78	\$2.81	\$2.94	\$2.98	\$2.94	\$2.94	\$2.94	\$2.81	\$2.78	\$2.81	\$2.80	\$2.80	\$2.95
Expected Case	2027-2028	Jan	\$2.85	\$2.85	\$2.85	\$2.91	\$2.93	\$2.91	\$2.91	\$2.91	\$2.85	\$2.85	\$2.85	\$2.85	\$2.85	\$2.91
Expected Case	2027-2028	Feb	\$2.79	\$2.74	\$2.84	\$2.83	\$2.90	\$2.83	\$2.83	\$2.79	\$2.74	\$2.84	\$2.79	\$2.79	\$2.84	\$2.84
Expected Case	2027-2028	Mar	\$2.62	\$2.62	\$2.71	\$2.68	\$2.71	\$2.68	\$2.68	\$2.68	\$2.62	\$2.62	\$2.71	\$2.65	\$2.65	\$2.68
Expected Case	2027-2028	Apr	\$2.33	\$2.33	\$2.69	\$2.38	\$2.69	\$2.69	\$2.69	\$2.69	\$2.33	\$2.33	\$2.69	\$2.45	\$2.45	\$2.63
Expected Case	2027-2028	May	\$2.43	\$2.43	\$2.69	\$2.48	\$2.69	\$2.48	\$2.48	\$2.48	\$2.43	\$2.43	\$2.69	\$2.52	\$2.52	\$2.63
Expected Case	2027-2028	Jun	\$2.41	\$2.41	\$2.69	\$2.46	\$2.69	\$2.46	\$2.46	\$2.46	\$2.41	\$2.41	\$2.69	\$2.50	\$2.50	\$2.50
Expected Case	2027-2028	Jul	\$2.41	\$2.41	\$2.69	\$2.46	\$2.69	\$2.46	\$2.46	\$2.46	\$2.41	\$2.41	\$2.69	\$2.51	\$2.51	\$2.51
Expected Case	2027-2028	Aug	\$2.43	\$2.43	\$2.69	\$2.48	\$2.69	\$2.48	\$2.48	\$2.48	\$2.43	\$2.43	\$2.69	\$2.52	\$2.52	\$2.52
Expected Case	2027-2028	Sep	\$2.48	\$2.48	\$2.69	\$2.53	\$2.69	\$2.53	\$2.53	\$2.53	\$2.48	\$2.48	\$2.69	\$2.55	\$2.55	\$2.57
Expected Case	2027-2028	Oct	\$2.57	\$2.57	\$3.34	\$2.62	\$3.34	\$2.62	\$2.62	\$2.62	\$2.57	\$2.57	\$3.34	\$2.83	\$2.83	\$2.77
Expected Case	2028-2029	Nov	\$2.85	\$2.85	\$2.97	\$2.91	\$2.97	\$2.91	\$2.91	\$2.91	\$2.85	\$2.85	\$2.97	\$2.89	\$2.89	\$2.92
Expected Case	2028-2029	Dec	\$2.96	\$2.90	\$2.98	\$3.10	\$3.14	\$3.10	\$3.10	\$3.10	\$2.96	\$2.90	\$2.98	\$2.95	\$2.95	\$3.11
Expected Case	2028-2029	Jan	\$3.02	\$3.02	\$3.02	\$3.08	\$3.10	\$3.08	\$3.08	\$3.08	\$3.02	\$3.02	\$3.02	\$3.02	\$3.02	\$3.08
Expected Case	2028-2029	Feb	\$2.93	\$2.88	\$3.01	\$2.98	\$3.05	\$2.98	\$2.98	\$2.98	\$2.93	\$2.88	\$3.01	\$2.94	\$2.94	\$2.99
Expected Case	2028-2029	Mar	\$2.73	\$2.73	\$2.90	\$2.78	\$2.90	\$2.78	\$2.78	\$2.78	\$2.73	\$2.73	\$2.90	\$2.78	\$2.78	\$2.80
Expected Case	2028-2029	Apr	\$2.52	\$2.52	\$3.11	\$2.57	\$3.11	\$3.11	\$3.11	\$3.11	\$2.52	\$2.52	\$3.11	\$2.72	\$2.72	\$3.00
Expected Case	2028-2029	May	\$2.58	\$2.58	\$2.84	\$2.63	\$2.84	\$2.63	\$2.63	\$2.63	\$2.58	\$2.58	\$2.84	\$2.67	\$2.67	\$2.67
Expected Case	2028-2029	Jun	\$2.57	\$2.57	\$2.84	\$2.63	\$2.84	\$2.63	\$2.63	\$2.63	\$2.57	\$2.57	\$2.84	\$2.66	\$2.66	\$2.67
Expected Case	2028-2029	Jul	\$2.56	\$2.56	\$2.84	\$2.61	\$2.84	\$2.61	\$2.61	\$2.61	\$2.56	\$2.56	\$2.84	\$2.65	\$2.65	\$2.65
Expected Case	2028-2029	Aug	\$2.56	\$2.56	\$2.84	\$2.61	\$2.84	\$2.61	\$2.61	\$2.61	\$2.56	\$2.56	\$2.84	\$2.65	\$2.65	\$2.65
Expected Case	2028-2029	Sep	\$2.61	\$2.61	\$2.84	\$2.66	\$2.84	\$2.66	\$2.66	\$2.66	\$2.61	\$2.61	\$2.84	\$2.69	\$2.69	\$2.70
Expected Case	2028-2029	Oct	\$2.66	\$2.66	\$3.44	\$2.71	\$3.44	\$2.71	\$2.71	\$2.71	\$2.66	\$2.66	\$3.44	\$2.92	\$2.92	\$2.86
Expected Case	2029-2030	Nov	\$2.96	\$2.96	\$3.07	\$3.02	\$3.07	\$3.02	\$3.02	\$3.02	\$2.96	\$2.96	\$3.07	\$3.00	\$3.00	\$3.08
Expected Case	2029-2030	Dec	\$3.09	\$3.09	\$3.09	\$3.27	\$3.31	\$3.27	\$3.27	\$3.27	\$3.09	\$3.09	\$3.09	\$3.09	\$3.09	\$3.28
Expected Case	2029-2030	Jan	\$3.12	\$3.12	\$3.12	\$3.18	\$3.21	\$3.18	\$3.18	\$3.18	\$3.12	\$3.12	\$3.12	\$3.12	\$3.12	\$3.19
Expected Case	2029-2030	Feb	\$3.05	\$3.00	\$3.12	\$3.10	\$3.16	\$3.10	\$3.10	\$3.10	\$3.05	\$3.00	\$3.12	\$3.06	\$3.06	\$3.11
Expected Case	2029-2030	Mar	\$2.87	\$2.87	\$3.00	\$2.93	\$3.00	\$2.93	\$2.93	\$2.93	\$2.87	\$2.87	\$3.00	\$2.91	\$2.91	\$2.94
Expected Case	2029-2030	Apr	\$2.63	\$2.63	\$3.25	\$2.69	\$3.25	\$2.69	\$2.69	\$2.69	\$2.63	\$2.63	\$3.25	\$2.84	\$2.84	\$3.14
Expected Case	2029-2030	May	\$2.67	\$2.67	\$2.92	\$2.72	\$2.92	\$2.72	\$2.72	\$2.72	\$2.67	\$2.67	\$2.92	\$2.75	\$2.75	\$2.76
Expected Case	2029-2030	Jun	\$2.64	\$2.64	\$2.92	\$2.69	\$2.92	\$2.69	\$2.69	\$2.69	\$2.64	\$2.64	\$2.92	\$2.73	\$2.73	\$2.74
Expected Case	2029-2030	Jul	\$2.59	\$2.59	\$2.92	\$2.64	\$2.92	\$2.64	\$2.64	\$2.64	\$2.59	\$2.59	\$2.92	\$2.70	\$2.70	\$2.69
Expected Case	2029-2030	Aug	\$2.61	\$2.61	\$2.92	\$2.66	\$2.92	\$2.66	\$2.66	\$2.66	\$2.61	\$2.61	\$2.92	\$2.72	\$2.72	\$2.72
Expected Case	2029-2030	Sep	\$2.67	\$2.67	\$2.92	\$2.72	\$2.92	\$2.72	\$2.72	\$2.72	\$2.67	\$2.67	\$2.92	\$2.75	\$2.75	\$2.76
Expected Case	2029-2030	Oct	\$2.80	\$2.80	\$3.41	\$2.86	\$3.41	\$2.86	\$2.86	\$2.86	\$2.80	\$2.80	\$3.41	\$3.00	\$3.00	\$2.97
Expected Case	2030-2031	Nov	\$3.11	\$3.10	\$3.20	\$3.16	\$3.20	\$3.16	\$3.16	\$3.16	\$3.11	\$3.10	\$3.20	\$3.14	\$3.14	\$3.17
Expected Case	2030-2031	Dec	\$3.25	\$3.25	\$3.25	\$3.43	\$3.46	\$3.43	\$3.43	\$3.43	\$3.25	\$3.25	\$3.25	\$3.25	\$3.25	\$3.43
Expected Case	2030-2031	Jan	\$3.26	\$3.26	\$3.26	\$3.32	\$3.35	\$3.32	\$3.32	\$3.32	\$3.26	\$3.26	\$3.26	\$3.26	\$3.26	\$3.32
Expected Case	2030-2031	Feb	\$3.21	\$3.16	\$3.25	\$3.27	\$3.31	\$3.27	\$3.27	\$3.27	\$3.21	\$3.16	\$3.25	\$3.21	\$3.21	\$3.27
Expected Case	2030-2031	Mar	\$2.99	\$2.99	\$3.11	\$3.05	\$3.11	\$3.05	\$3.05	\$3.05	\$2.99	\$2.99	\$3.11	\$3.03	\$3.03	\$3.06
Expected Case	2030-2031	Apr	\$2.78	\$2.78	\$3.43	\$2.83	\$3.43	\$3.43	\$3.43	\$3.43	\$2.78	\$2.78	\$3.43	\$3.00	\$3.00	\$3.31
Expected Case	2030-2031	May	\$2.80	\$2.80	\$3.10	\$2.85	\$3.10	\$2.85	\$2.85	\$2.85	\$2.80	\$2.80	\$3.10	\$2.90	\$2.90	\$2.90
Expected Case	2030-2031	Jun	\$2.77	\$2.77	\$3.10	\$2.82	\$3.10	\$2.82	\$2.82	\$2.82	\$2.77	\$2.77	\$3.10	\$2.88	\$2.88	\$2.88
Expected Case	2030-2031	Jul	\$2.73	\$2.73	\$3.10	\$2.78	\$3.10	\$2.78	\$2.78	\$2.78	\$2.73	\$2.73	\$3.10	\$2.85	\$2.85	\$2.84
Expected Case	2030-2031	Aug	\$2.72	\$2.72	\$3.10	\$2.78	\$3.10	\$2.78	\$2.78	\$2.78	\$2.72	\$2.72	\$3.10	\$2.85	\$2.85	\$2.84
Expected Case	2030-2031	Sep	\$2.83	\$2.83	\$3.10	\$2.88	\$3.10	\$2.88	\$2.88	\$2.88	\$2.83	\$2.83	\$3.10	\$2.92	\$2.92	\$2.92
Expected Case	2030-2031	Oct	\$2.88	\$2.88	\$3.51	\$2.94	\$3.51	\$2.94	\$2.94	\$2.94	\$2.88	\$2.88	\$3.51	\$3.09	\$3.09	\$3.05
Expected Case	2031-2032	Nov	\$3.24	\$3.23	\$3.30	\$3.29	\$3.30	\$3.29	\$3.29	\$3.29	\$3.24	\$3.23	\$3.30	\$3.25	\$3.25	\$3.29
Expected Case	2031-2032	Dec	\$3.34	\$3.33	\$3.34	\$3.53	\$3.56	\$3.53	\$3.53	\$3.53	\$3.34	\$3.33	\$3.34	\$3.33	\$3.33	\$3.54
Expected Case	2031-2032	Jan	\$3.35	\$3.35	\$3.35	\$3.42	\$3.45	\$3.42	\$3.42	\$3.42	\$3.35	\$3.35	\$3.35	\$3.35	\$3.35	\$3.42
Expected Case	2031-2032	Feb	\$3.29	\$3.22	\$3.35	\$3.32	\$3.42	\$3.32	\$3.32	\$3.32	\$3.29	\$3.22	\$3.35	\$3.29	\$3.29	\$3.34
Expected Case	2031-2032	Mar	\$3.06	\$3.06	\$3.20	\$3.12	\$3.20	\$3.12	\$3.12	\$3.12	\$3.06	\$3.06	\$3.20	\$3.11	\$3.11	\$3.14
Expected Case	2031-2032	Apr	\$2.89	\$2.89	\$3.56	\$2.95	\$3.56	\$2.95	\$2.95	\$2.89	\$2.89	\$3.56	\$3.12	\$3.12	\$3.44	
Expected Case	2031-2032	May	\$2.87	\$2.87	\$3.14	\$2.93	\$3.14	\$2.93	\$2.93	\$2.87	\$2.87	\$3.14	\$2.96	\$2.96	\$2.97	
Expected Case	2031-2032	Jun	\$2.83	\$2.83	\$3.15	\$2.89	\$3.14	\$2.89	\$2.89	\$2.89	\$2.83	\$2.83	\$3.15	\$2.93	\$2.93	\$2.94
Expected Case	2031-2032	Jul	\$2.65	\$2.65	\$3.15	\$2.70	\$3.15	\$2.70	\$2.70	\$2.70	\$2.65	\$2.65	\$3.15	\$2.81	\$2.81	\$2.79
Expected Case	2031-2032	Aug	\$2.68	\$2.68	\$3.15	\$2.73	\$3.15	\$2.73	\$2.73	\$2.73	\$2.68	\$2.68	\$3.15	\$2.83	\$2.83	\$2.81
Expected Case	2031-2032	Sep	\$2.87	\$2.87	\$3.15	\$2.93	\$3.15	\$2.93	\$2.93	\$2.87	\$2.87	\$3.15	\$2.96	\$2.96	\$2.97	
Expected Case	2031-2032	Oct	\$2.99	\$2.99	\$3.63	\$3.05	\$3.63	\$3.05	\$3.05	\$3.05	\$2.99	\$2.99	\$3.63	\$3.21	\$3.21	\$3.17
Expected Case	2032-2033	Nov	\$3.40	\$3.38	\$3.51	\$3.45	\$3.51	\$3.45	\$3.45	\$3.45	\$3.40	\$3.38	\$3.51	\$3.43	\$3.43	\$3.46
Expected Case	2032-2033	Dec	\$3.52	\$3.49	\$3.52	\$3.73	\$3.76	\$3.73	\$3.73	\$3.73	\$3.52	\$3.49	\$3.52	\$3.51	\$3.51	\$3.74
Expected Case	2032-2033	Jan	\$3.57	\$3.57	\$3.57	\$3.64	\$3.67	\$3.64	\$3.64	\$3.64	\$3.57	\$3.57	\$3.57	\$3.57	\$3.57	\$3.64
Expected Case	2032-2033	Feb	\$3.54	\$3.51	\$3.55	\$3.62	\$3.67	\$3.62	\$3.62	\$3.62	\$3.54	\$3.51	\$3.55	\$3.53	\$3.53	\$3.63
Expected Case	2032-2033	Mar	\$3.35	\$3.35	\$3.44	\$3.42	\$3.44	\$3.42	\$3.42	\$3.42	\$3.35	\$3.35	\$3.44	\$3.38	\$3.38	\$3.42
Expected Case	2032-2033	Apr	\$3.16	\$3.16	\$3.81	\$3.22	\$3.81	\$3.81	\$3.81	\$3.81	\$3.16	\$3.16	\$3.81	\$3.38	\$3.38	\$3.69
Expected Case	2032-2033	May	\$3.14	\$3.14	\$3.44	\$3.21	\$3.44	\$3.21	\$3.21	\$3.21	\$3.14	\$3.14	\$3.44	\$3.24	\$3.24	\$3.25
Expected Case	2032-2033	Jun	\$3.15	\$3.15	\$3.45	\$3.21	\$3.45	\$3.21	\$3.21	\$3.21	\$3.15	\$3.15	\$3.45	\$3.25	\$3.25	\$3.26
Expected Case	2032-2033	Jul	\$3.02	\$3.02	\$3.45	\$3.08	\$3.45	\$3.08	\$3.08	\$3.08	\$3.02	\$3.02	\$3.45	\$3.16	\$3.16	\$3.15
Expected Case	2032-2033	Aug	\$3.04	\$3.04	\$3.45	\$3.10	\$3.45	\$3.10	\$3.10	\$3.10	\$3.04	\$3.04	\$3.45	\$3.18	\$3.18	\$3.17
Expected Case	2032-2033	Sep	\$3.17	\$3.17	\$3.45	\$3.23	\$3.45	\$3.23	\$3.23	\$3.23	\$3.17	\$3.17	\$3.45	\$3.26	\$3.26	\$3.28
Expected Case	2032-2033	Oct	\$3.26	\$3.26	\$3.88	\$3.32	\$3.88	\$3.32	\$3.32	\$3.32	\$3.26	\$3.26	\$3.88	\$3.47	\$3.47	\$3.43
Expected Case	2033-2034	Nov	\$3.68	\$3.67	\$3.73	\$3.74	\$3.74	\$3.74	\$3.74	\$3.74	\$3.68	\$3.67	\$3.73	\$3.69	\$3.69	\$3.74
Expected Case	2033-2034	Dec	\$3.75	\$3.73	\$3.75	\$3.97	\$4.00	\$3.97	\$3.97	\$3.97	\$3.75	\$3.73	\$3.75	\$3.74	\$3.74	\$3.97
Expected Case	2033-2034	Jan	\$3.79	\$3.78	\$3.79	\$3.86	\$3.89	\$3.86	\$3.86	\$3.86	\$3.79	\$3.78	\$3.79	\$3.78	\$3.78	\$3.86
Expected Case	2033-2034	Feb	\$3.75	\$3.67	\$3.78	\$3.78	\$3.85	\$3.78	\$3.78	\$3.78	\$3.75	\$3.67	\$3.78	\$3.73	\$3.73	\$3.79
Expected Case	2033-2034	Mar	\$3.52	\$3.52	\$3.63	\$3.59	\$3.63	\$3.59	\$3.59	\$3.59	\$3.52	\$3.52	\$3.63	\$3.56	\$3.56	\$3.60
Expected Case	2033-2034	Apr	\$3.31	\$3.31	\$3.96	\$3.38	\$3.96	\$3.96	\$3.96	\$3.96	\$3.31	\$3.31	\$3			

Monthly Avoided Costs ¹																
Nominal \$																
Scenario	Gas Year	Month	ID Both	ID GTN	ID NWP	Klamath Falls	La Grande	Medford GTN	Medford NWP	Roseburg	WA Both	WA GTN	WA NWP	Idaho	Washington	Oregon
Expected Case	2035-2036	Jan	\$4.14	\$4.12	\$4.14	\$4.20	\$4.23	\$4.20	\$4.20	\$4.20	\$4.14	\$4.12	\$4.14	\$4.13	\$4.13	\$4.21
Expected Case	2035-2036	Feb	\$4.16	\$4.05	\$4.18	\$4.17	\$4.26	\$4.17	\$4.17	\$4.17	\$4.16	\$4.05	\$4.18	\$4.13	\$4.13	\$4.19
Expected Case	2035-2036	Mar	\$3.86	\$3.86	\$4.03	\$3.93	\$4.03	\$3.93	\$3.93	\$3.93	\$3.86	\$3.86	\$4.03	\$3.92	\$3.92	\$3.95
Expected Case	2035-2036	Apr	\$3.62	\$3.62	\$4.16	\$3.69	\$4.16	\$4.16	\$4.16	\$4.16	\$3.62	\$3.62	\$4.16	\$3.80	\$3.80	\$4.06
Expected Case	2035-2036	May	\$3.62	\$3.62	\$3.85	\$3.69	\$3.85	\$3.69	\$3.69	\$3.69	\$3.62	\$3.62	\$3.85	\$3.69	\$3.69	\$3.72
Expected Case	2035-2036	Jun	\$3.60	\$3.60	\$3.85	\$3.67	\$3.85	\$3.67	\$3.67	\$3.67	\$3.60	\$3.60	\$3.85	\$3.68	\$3.68	\$3.70
Expected Case	2035-2036	Jul	\$3.39	\$3.39	\$3.85	\$3.45	\$3.85	\$3.45	\$3.45	\$3.45	\$3.39	\$3.39	\$3.85	\$3.54	\$3.54	\$3.53
Expected Case	2035-2036	Aug	\$3.42	\$3.42	\$3.85	\$3.48	\$3.85	\$3.48	\$3.48	\$3.48	\$3.42	\$3.42	\$3.85	\$3.56	\$3.56	\$3.56
Expected Case	2035-2036	Sep	\$3.57	\$3.57	\$3.85	\$3.64	\$3.85	\$3.64	\$3.64	\$3.64	\$3.57	\$3.57	\$3.85	\$3.66	\$3.66	\$3.68
Expected Case	2035-2036	Oct	\$3.73	\$3.73	\$4.29	\$3.80	\$4.29	\$4.29	\$4.29	\$4.29	\$3.73	\$3.73	\$4.29	\$3.91	\$3.91	\$4.19
Expected Case	2036-2037	Nov	\$4.16	\$4.14	\$4.32	\$4.22	\$4.32	\$4.22	\$4.22	\$4.22	\$4.16	\$4.14	\$4.32	\$4.21	\$4.21	\$4.24
Expected Case	2036-2037	Dec	\$4.35	\$4.27	\$4.35	\$5.19	\$5.21	\$5.19	\$5.19	\$5.19	\$4.35	\$4.27	\$4.35	\$4.32	\$4.32	\$5.20
Expected Case	2036-2037	Jan	\$4.34	\$4.32	\$4.34	\$4.41	\$4.44	\$4.41	\$4.41	\$4.41	\$4.34	\$4.32	\$4.34	\$4.33	\$4.33	\$4.41
Expected Case	2036-2037	Feb	\$4.32	\$4.11	\$4.37	\$4.23	\$4.44	\$4.23	\$4.23	\$4.23	\$4.32	\$4.11	\$4.37	\$4.27	\$4.27	\$4.28
Expected Case	2036-2037	Mar	\$3.93	\$3.93	\$4.27	\$4.01	\$4.27	\$4.01	\$4.01	\$4.01	\$3.93	\$3.93	\$4.27	\$4.05	\$4.05	\$4.06
Expected Case	2036-2037	Apr	\$3.66	\$3.66	\$4.22	\$3.73	\$4.22	\$4.22	\$4.22	\$4.22	\$3.66	\$3.66	\$4.22	\$3.85	\$3.85	\$4.12
Expected Case	2036-2037	May	\$3.80	\$3.80	\$4.09	\$3.87	\$4.09	\$3.87	\$3.87	\$3.87	\$3.80	\$3.80	\$4.09	\$3.89	\$3.89	\$3.91
Expected Case	2036-2037	Jun	\$3.77	\$3.77	\$4.09	\$3.85	\$4.09	\$3.85	\$3.85	\$3.85	\$3.77	\$3.77	\$4.09	\$3.88	\$3.88	\$3.89
Expected Case	2036-2037	Jul	\$3.65	\$3.65	\$4.09	\$3.72	\$4.09	\$3.72	\$3.72	\$3.72	\$3.65	\$3.65	\$4.09	\$3.79	\$3.79	\$3.79
Expected Case	2036-2037	Aug	\$3.74	\$3.74	\$4.09	\$3.81	\$4.09	\$3.81	\$3.81	\$3.81	\$3.74	\$3.74	\$4.09	\$3.86	\$3.86	\$3.87
Expected Case	2036-2037	Sep	\$3.84	\$3.84	\$4.09	\$3.91	\$4.09	\$3.91	\$3.91	\$3.91	\$3.84	\$3.84	\$4.09	\$3.92	\$3.92	\$3.95
Expected Case	2036-2037	Oct	\$3.97	\$3.97	\$4.53	\$4.05	\$4.53	\$4.53	\$4.53	\$4.53	\$3.97	\$3.97	\$4.53	\$4.16	\$4.16	\$4.43
Expected Case	2037-2038	Nov	\$4.47	\$4.44	\$4.60	\$4.52	\$4.60	\$4.52	\$4.52	\$4.52	\$4.47	\$4.44	\$4.60	\$4.51	\$4.51	\$4.54
Expected Case	2037-2038	Dec	\$4.65	\$4.61	\$4.65	\$5.49	\$5.51	\$5.49	\$5.49	\$5.49	\$4.65	\$4.61	\$4.65	\$4.63	\$4.63	\$5.50
Expected Case	2037-2038	Jan	\$4.64	\$4.63	\$4.64	\$4.72	\$4.86	\$4.72	\$4.72	\$4.72	\$4.64	\$4.63	\$4.64	\$4.64	\$4.64	\$4.75
Expected Case	2037-2038	Feb	\$4.61	\$4.34	\$4.67	\$4.50	\$4.71	\$4.50	\$4.50	\$4.50	\$4.61	\$4.34	\$4.67	\$4.54	\$4.54	\$4.54
Expected Case	2037-2038	Mar	\$4.08	\$4.08	\$4.55	\$4.16	\$4.55	\$4.16	\$4.16	\$4.16	\$4.08	\$4.08	\$4.55	\$4.24	\$4.24	\$4.24
Expected Case	2037-2038	Apr	\$3.87	\$3.87	\$4.40	\$3.95	\$4.40	\$4.40	\$4.40	\$4.40	\$3.87	\$3.87	\$4.40	\$4.05	\$4.05	\$4.31
Expected Case	2037-2038	May	\$3.91	\$3.91	\$4.13	\$3.98	\$4.13	\$3.98	\$3.98	\$3.98	\$3.91	\$3.91	\$4.13	\$3.98	\$3.98	\$4.01
Expected Case	2037-2038	Jun	\$3.91	\$3.91	\$4.13	\$3.99	\$4.13	\$3.99	\$3.99	\$3.99	\$3.91	\$3.91	\$4.13	\$3.98	\$3.98	\$4.01
Expected Case	2037-2038	Jul	\$3.74	\$3.74	\$4.13	\$3.82	\$4.13	\$3.82	\$3.82	\$3.82	\$3.74	\$3.74	\$4.13	\$3.87	\$3.87	\$3.88
Expected Case	2037-2038	Aug	\$3.77	\$3.77	\$4.13	\$3.84	\$4.13	\$3.84	\$3.84	\$3.84	\$3.77	\$3.77	\$4.13	\$3.89	\$3.89	\$3.90
Expected Case	2037-2038	Sep	\$3.87	\$3.87	\$4.13	\$3.95	\$4.13	\$3.95	\$3.95	\$3.95	\$3.87	\$3.87	\$4.13	\$3.96	\$3.96	\$3.98
Expected Case	2037-2038	Oct	\$4.00	\$4.00	\$4.54	\$4.08	\$4.54	\$4.54	\$4.54	\$4.54	\$4.00	\$4.00	\$4.54	\$4.18	\$4.18	\$4.45
Expected Case	2038-2039	Nov	\$4.53	\$4.46	\$4.84	\$4.54	\$4.84	\$4.54	\$4.54	\$4.54	\$4.53	\$4.46	\$4.84	\$4.61	\$4.61	\$4.60
Expected Case	2038-2039	Dec	\$4.89	\$4.67	\$4.89	\$5.63	\$5.66	\$5.63	\$5.63	\$5.63	\$4.89	\$4.67	\$4.89	\$4.81	\$4.81	\$5.64
Expected Case	2038-2039	Jan	\$4.87	\$4.73	\$4.87	\$4.82	\$5.01	\$4.82	\$4.82	\$4.82	\$4.87	\$4.73	\$4.87	\$4.83	\$4.83	\$4.86
Expected Case	2038-2039	Feb	\$4.82	\$4.51	\$4.90	\$4.64	\$4.94	\$4.64	\$4.64	\$4.64	\$4.82	\$4.51	\$4.90	\$4.75	\$4.75	\$4.70
Expected Case	2038-2039	Mar	\$4.37	\$4.37	\$4.81	\$4.45	\$4.81	\$4.45	\$4.45	\$4.45	\$4.37	\$4.37	\$4.81	\$4.52	\$4.52	\$4.52
Expected Case	2038-2039	Apr	\$4.13	\$4.13	\$4.65	\$4.20	\$4.65	\$4.65	\$4.65	\$4.65	\$4.13	\$4.13	\$4.65	\$4.30	\$4.30	\$4.56
Expected Case	2038-2039	May	\$4.16	\$4.16	\$4.39	\$4.24	\$4.39	\$4.24	\$4.24	\$4.24	\$4.16	\$4.16	\$4.39	\$4.23	\$4.23	\$4.27
Expected Case	2038-2039	Jun	\$4.07	\$4.07	\$4.39	\$4.15	\$4.39	\$4.15	\$4.15	\$4.15	\$4.07	\$4.07	\$4.39	\$4.18	\$4.18	\$4.20
Expected Case	2038-2039	Jul	\$3.94	\$3.94	\$4.39	\$4.01	\$4.39	\$4.01	\$4.01	\$4.01	\$3.94	\$3.94	\$4.39	\$4.09	\$4.09	\$4.09
Expected Case	2038-2039	Aug	\$3.94	\$3.94	\$4.39	\$4.02	\$4.39	\$4.02	\$4.02	\$4.02	\$3.94	\$3.94	\$4.39	\$4.09	\$4.09	\$4.09
Expected Case	2038-2039	Sep	\$4.13	\$4.13	\$4.39	\$4.20	\$4.39	\$4.20	\$4.20	\$4.20	\$4.13	\$4.13	\$4.39	\$4.21	\$4.21	\$4.24
Expected Case	2038-2039	Oct	\$4.24	\$4.24	\$4.78	\$4.32	\$4.78	\$4.78	\$4.78	\$4.78	\$4.24	\$4.24	\$4.78	\$4.42	\$4.42	\$4.69
Expected Case	2039-2040	Nov	\$4.86	\$4.74	\$5.14	\$4.83	\$5.14	\$4.83	\$4.83	\$4.83	\$4.86	\$4.74	\$5.14	\$4.91	\$4.91	\$4.89
Expected Case	2039-2040	Dec	\$5.19	\$4.89	\$5.19	\$5.99	\$6.02	\$5.99	\$5.99	\$5.99	\$5.19	\$4.89	\$5.19	\$5.09	\$5.09	\$5.99
Expected Case	2039-2040	Jan	\$5.18	\$4.91	\$5.18	\$5.01	\$5.30	\$5.01	\$5.01	\$5.01	\$5.18	\$4.91	\$5.18	\$5.09	\$5.09	\$5.06
Expected Case	2039-2040	Feb	\$5.14	\$4.68	\$5.21	\$4.82	\$5.24	\$4.82	\$4.82	\$4.82	\$5.14	\$4.68	\$5.21	\$5.01	\$5.01	\$4.90
Expected Case	2039-2040	Mar	\$4.51	\$4.51	\$5.12	\$4.59	\$5.12	\$4.59	\$4.59	\$4.59	\$4.51	\$4.51	\$5.12	\$4.71	\$4.71	\$4.70
Expected Case	2039-2040	Apr	\$4.28	\$4.28	\$4.82	\$4.36	\$4.82	\$4.82	\$4.82	\$4.82	\$4.28	\$4.28	\$4.82	\$4.46	\$4.46	\$4.73
Expected Case	2039-2040	May	\$4.31	\$4.31	\$4.55	\$4.40	\$4.55	\$4.40	\$4.40	\$4.40	\$4.31	\$4.31	\$4.55	\$4.39	\$4.39	\$4.43
Expected Case	2039-2040	Jun	\$4.29	\$4.29	\$4.55	\$4.37	\$4.55	\$4.37	\$4.37	\$4.37	\$4.29	\$4.29	\$4.55	\$4.38	\$4.38	\$4.41
Expected Case	2039-2040	Jul	\$4.17	\$4.17	\$4.55	\$4.25	\$4.55	\$4.25	\$4.25	\$4.25	\$4.17	\$4.17	\$4.55	\$4.30	\$4.30	\$4.31
Expected Case	2039-2040	Aug	\$4.21	\$4.21	\$4.55	\$4.29	\$4.55	\$4.29	\$4.29	\$4.29	\$4.21	\$4.21	\$4.55	\$4.32	\$4.32	\$4.34
Expected Case	2039-2040	Sep	\$4.34	\$4.34	\$4.55	\$4.43	\$4.55	\$4.43	\$4.43	\$4.43	\$4.34	\$4.34	\$4.55	\$4.41	\$4.41	\$4.45
Expected Case	2039-2040	Oct	\$4.46	\$4.46	\$4.99	\$4.54	\$4.99	\$4.99	\$4.99	\$4.99	\$4.46	\$4.46	\$4.99	\$4.63	\$4.63	\$4.90

¹Avoided costs are before Environmental Externalities adder

APPENDIX 6.4: HIGH GROWTH & LOW PRICES MONTHLY DETAIL

Scenario	Gas Year	Month	Monthly Avoided Costs ⁴													Idaho	Washington	Oregon
			Nominal \$															
			ID Both	ID GTN	ID NWP	Klamath Falls	La Grande	Medford GTN	Medford NWP	Roseburg	WA Both	WA GTN	WA NWP					
High Growth & Low Prices	2019-2020	Nov	\$2.00	\$2.18	\$2.00	\$2.22	\$2.22	\$2.22	\$2.22	\$2.22	\$2.22	\$2.22	\$2.00	\$2.18	\$2.00	\$2.06	\$2.06	\$2.22
High Growth & Low Prices	2019-2020	Dec	\$1.99	\$1.87	\$1.99	\$2.17	\$2.25	\$2.17	\$2.17	\$2.17	\$2.17	\$1.99	\$1.87	\$1.99	\$1.95	\$1.95	\$2.19	
High Growth & Low Prices	2019-2020	Jan	\$2.00	\$1.80	\$2.00	\$1.84	\$2.02	\$1.84	\$1.84	\$1.84	\$2.00	\$1.80	\$2.00	\$1.93	\$1.93	\$1.88		
High Growth & Low Prices	2019-2020	Feb	\$1.95	\$1.43	\$1.97	\$1.50	\$1.97	\$1.50	\$1.50	\$1.50	\$1.95	\$1.43	\$1.97	\$1.79	\$1.79	\$1.60		
High Growth & Low Prices	2019-2020	Mar	\$1.25	\$1.25	\$1.38	\$1.28	\$1.38	\$1.28	\$1.28	\$1.28	\$1.25	\$1.25	\$1.38	\$1.30	\$1.30	\$1.30		
High Growth & Low Prices	2019-2020	Apr	\$1.03	\$1.03	\$1.15	\$1.05	\$1.14	\$1.15	\$1.15	\$1.15	\$1.03	\$1.03	\$1.15	\$1.07	\$1.07	\$1.13		
High Growth & Low Prices	2019-2020	May	\$1.05	\$1.14	\$1.05	\$1.07	\$1.05	\$1.05	\$1.05	\$1.05	\$1.05	\$1.14	\$1.05	\$1.08	\$1.08	\$1.06		
High Growth & Low Prices	2019-2020	Jun	\$0.90	\$0.90	\$1.06	\$0.86	\$0.90	\$0.86	\$0.86	\$0.86	\$0.90	\$0.90	\$1.06	\$0.95	\$0.95	\$0.87		
High Growth & Low Prices	2019-2020	Jul	\$0.86	\$0.86	\$1.06	\$0.80	\$0.90	\$0.80	\$0.80	\$0.80	\$0.86	\$0.86	\$1.06	\$0.93	\$0.93	\$0.82		
High Growth & Low Prices	2019-2020	Aug	\$1.10	\$1.10	\$1.13	\$1.13	\$1.13	\$1.13	\$1.13	\$1.13	\$1.10	\$1.10	\$1.13	\$1.11	\$1.11	\$1.13		
High Growth & Low Prices	2019-2020	Sep	\$0.99	\$0.99	\$1.06	\$1.01	\$1.06	\$1.01	\$1.01	\$1.01	\$0.99	\$0.99	\$1.06	\$1.01	\$1.01	\$1.02		
High Growth & Low Prices	2019-2020	Oct	\$1.02	\$1.02	\$1.31	\$1.04	\$1.31	\$1.04	\$1.04	\$1.04	\$1.02	\$1.02	\$1.31	\$1.12	\$1.12	\$1.10		
High Growth & Low Prices	2020-2021	Nov	\$1.81	\$0.81	\$1.82	\$1.74	\$1.82	\$1.74	\$1.74	\$1.74	\$1.81	\$1.81	\$1.82	\$1.81	\$1.81	\$1.75		
High Growth & Low Prices	2020-2021	Dec	\$2.01	\$2.36	\$2.01	\$2.41	\$2.41	\$2.41	\$2.41	\$2.41	\$2.01	\$2.36	\$2.01	\$2.13	\$2.13	\$2.41		
High Growth & Low Prices	2020-2021	Jan	\$1.93	\$1.80	\$1.93	\$1.83	\$1.93	\$1.83	\$1.83	\$1.83	\$1.93	\$1.80	\$1.93	\$1.88	\$1.88	\$1.85		
High Growth & Low Prices	2020-2021	Feb	\$2.02	\$1.69	\$2.02	\$1.75	\$2.02	\$1.75	\$1.75	\$1.75	\$2.02	\$1.69	\$2.02	\$1.91	\$1.91	\$1.81		
High Growth & Low Prices	2020-2021	Mar	\$1.38	\$1.38	\$1.67	\$1.41	\$1.67	\$1.41	\$1.41	\$1.41	\$1.38	\$1.38	\$1.67	\$1.47	\$1.47	\$1.46		
High Growth & Low Prices	2020-2021	Apr	\$0.91	\$0.91	\$1.27	\$0.93	\$1.27	\$1.25	\$1.25	\$1.25	\$0.91	\$0.91	\$1.27	\$1.03	\$1.03	\$1.19		
High Growth & Low Prices	2020-2021	May	\$0.81	\$0.81	\$1.28	\$0.83	\$1.24	\$0.83	\$0.83	\$0.83	\$0.81	\$0.81	\$1.28	\$0.96	\$0.96	\$0.91		
High Growth & Low Prices	2020-2021	Jun	\$0.85	\$0.85	\$1.28	\$0.87	\$1.22	\$0.87	\$0.87	\$0.87	\$0.85	\$0.85	\$1.28	\$0.99	\$0.99	\$0.94		
High Growth & Low Prices	2020-2021	Jul	\$0.96	\$0.96	\$1.28	\$0.99	\$1.28	\$0.99	\$0.99	\$0.99	\$0.96	\$0.96	\$1.28	\$1.07	\$1.07	\$1.05		
High Growth & Low Prices	2020-2021	Aug	\$0.96	\$0.96	\$1.28	\$0.98	\$1.28	\$0.98	\$0.98	\$0.98	\$0.96	\$0.96	\$1.28	\$1.06	\$1.06	\$1.04		
High Growth & Low Prices	2020-2021	Sep	\$0.81	\$0.81	\$1.28	\$0.83	\$1.28	\$0.83	\$0.83	\$0.83	\$0.81	\$0.81	\$1.28	\$0.96	\$0.96	\$0.92		
High Growth & Low Prices	2020-2021	Oct	\$0.83	\$0.83	\$1.44	\$0.85	\$1.44	\$0.85	\$0.85	\$0.85	\$0.83	\$0.83	\$1.44	\$1.03	\$1.03	\$0.97		
High Growth & Low Prices	2021-2022	Nov	\$1.30	\$1.17	\$1.62	\$1.19	\$1.62	\$1.19	\$1.19	\$1.19	\$1.30	\$1.17	\$1.62	\$1.36	\$1.36	\$1.28		
High Growth & Low Prices	2021-2022	Dec	\$1.65	\$1.40	\$1.65	\$1.64	\$1.69	\$1.64	\$1.64	\$1.64	\$1.65	\$1.40	\$1.65	\$1.57	\$1.57	\$1.65		
High Growth & Low Prices	2021-2022	Jan	\$1.65	\$1.48	\$1.65	\$1.51	\$1.69	\$1.51	\$1.51	\$1.51	\$1.65	\$1.48	\$1.65	\$1.59	\$1.59	\$1.55		
High Growth & Low Prices	2021-2022	Feb	\$1.67	\$1.34	\$1.67	\$1.42	\$1.67	\$1.42	\$1.42	\$1.42	\$1.67	\$1.34	\$1.67	\$1.56	\$1.56	\$1.47		
High Growth & Low Prices	2021-2022	Mar	\$1.06	\$1.06	\$1.59	\$1.09	\$1.59	\$1.09	\$1.09	\$1.09	\$1.06	\$1.06	\$1.59	\$1.24	\$1.24	\$1.19		
High Growth & Low Prices	2021-2022	Apr	\$0.52	\$0.52	\$1.10	\$0.54	\$1.10	\$1.04	\$1.04	\$1.04	\$0.52	\$0.52	\$1.10	\$0.72	\$0.72	\$0.95		
High Growth & Low Prices	2021-2022	May	\$0.50	\$0.50	\$1.10	\$0.51	\$1.10	\$0.51	\$0.51	\$0.51	\$0.50	\$0.50	\$1.10	\$0.70	\$0.70	\$0.63		
High Growth & Low Prices	2021-2022	Jun	\$0.60	\$0.60	\$1.10	\$0.62	\$1.10	\$0.62	\$0.62	\$0.62	\$0.60	\$0.60	\$1.10	\$0.77	\$0.77	\$0.71		
High Growth & Low Prices	2021-2022	Jul	\$0.74	\$0.74	\$1.10	\$0.76	\$1.10	\$0.76	\$0.76	\$0.76	\$0.74	\$0.74	\$1.10	\$0.86	\$0.86	\$0.83		
High Growth & Low Prices	2021-2022	Aug	\$0.68	\$0.68	\$1.11	\$0.70	\$1.11	\$0.70	\$0.70	\$0.70	\$0.68	\$0.68	\$1.11	\$0.82	\$0.82	\$0.78		
High Growth & Low Prices	2021-2022	Sep	\$0.51	\$0.51	\$1.11	\$0.52	\$1.11	\$0.52	\$0.52	\$0.52	\$0.51	\$0.51	\$1.11	\$0.71	\$0.71	\$0.64		
High Growth & Low Prices	2021-2022	Oct	\$0.50	\$0.50	\$1.11	\$0.52	\$1.11	\$0.52	\$0.52	\$0.52	\$0.50	\$0.50	\$1.11	\$0.70	\$0.70	\$0.63		
High Growth & Low Prices	2022-2023	Nov	\$0.96	\$0.77	\$1.40	\$0.79	\$1.40	\$0.79	\$0.79	\$0.79	\$0.96	\$0.77	\$1.40	\$1.04	\$1.04	\$0.91		
High Growth & Low Prices	2022-2023	Dec	\$1.43	\$1.21	\$1.43	\$1.61	\$1.63	\$1.61	\$1.61	\$1.61	\$1.43	\$1.21	\$1.43	\$1.35	\$1.35	\$1.61		
High Growth & Low Prices	2022-2023	Jan	\$1.43	\$1.27	\$1.43	\$1.30	\$1.50	\$1.30	\$1.30	\$1.30	\$1.43	\$1.27	\$1.43	\$1.37	\$1.37	\$1.34		
High Growth & Low Prices	2022-2023	Feb	\$1.46	\$1.07	\$1.46	\$1.15	\$1.46	\$1.15	\$1.15	\$1.15	\$1.46	\$1.07	\$1.46	\$1.33	\$1.33	\$1.21		
High Growth & Low Prices	2022-2023	Mar	\$0.84	\$0.84	\$1.32	\$0.86	\$1.32	\$0.86	\$0.86	\$0.86	\$0.84	\$0.84	\$1.32	\$1.00	\$1.00	\$0.95		
High Growth & Low Prices	2022-2023	Apr	\$0.42	\$0.42	\$1.02	\$0.43	\$1.02	\$0.97	\$0.97	\$0.97	\$0.42	\$0.42	\$1.02	\$0.62	\$0.62	\$0.87		
High Growth & Low Prices	2022-2023	May	\$0.40	\$0.40	\$1.02	\$0.41	\$0.99	\$0.41	\$0.41	\$0.41	\$0.40	\$0.40	\$1.02	\$0.61	\$0.61	\$0.53		
High Growth & Low Prices	2022-2023	Jun	\$0.56	\$0.56	\$1.02	\$0.58	\$1.02	\$0.58	\$0.58	\$0.58	\$0.56	\$0.56	\$1.02	\$0.72	\$0.72	\$0.67		
High Growth & Low Prices	2022-2023	Jul	\$0.60	\$0.60	\$1.02	\$0.62	\$1.02	\$0.62	\$0.62	\$0.62	\$0.60	\$0.60	\$1.02	\$0.74	\$0.74	\$0.70		
High Growth & Low Prices	2022-2023	Aug	\$0.60	\$0.60	\$1.02	\$0.62	\$1.02	\$0.62	\$0.62	\$0.62	\$0.60	\$0.60	\$1.02	\$0.74	\$0.74	\$0.70		
High Growth & Low Prices	2022-2023	Sep	\$0.33	\$0.33	\$1.02	\$0.34	\$1.02	\$0.34	\$0.34	\$0.34	\$0.33	\$0.33	\$1.02	\$0.56	\$0.56	\$0.48		
High Growth & Low Prices	2022-2023	Oct	\$0.41	\$0.41	\$1.06	\$0.43	\$1.06	\$0.43	\$0.43	\$0.43	\$0.41	\$0.41	\$1.06	\$0.63	\$0.63	\$0.55		
High Growth & Low Prices	2023-2024	Nov	\$1.08	\$0.90	\$1.35	\$0.92	\$1.35	\$0.92	\$0.92	\$0.92	\$1.08	\$0.90	\$1.35	\$1.11	\$1.11	\$1.01		
High Growth & Low Prices	2023-2024	Dec	\$1.38	\$1.10	\$1.38	\$1.47	\$1.50	\$1.47	\$1.47	\$1.47	\$1.38	\$1.10	\$1.38	\$1.29	\$1.29	\$1.48		
High Growth & Low Prices	2023-2024	Jan	\$1.38	\$1.24	\$1.38	\$1.27	\$1.51	\$1.27	\$1.27	\$1.27	\$1.38	\$1.24	\$1.38	\$1.33	\$1.33	\$1.32		
High Growth & Low Prices	2023-2024	Feb	\$1.41	\$0.97	\$1.41	\$0.99	\$1.41	\$0.99	\$0.99	\$0.99	\$1.41	\$0.97	\$1.41	\$1.26	\$1.26	\$1.08		
High Growth & Low Prices	2023-2024	Mar	\$0.93	\$0.91	\$1.31	\$0.93	\$1.31	\$0.93	\$0.93	\$0.93	\$0.93	\$0.91	\$1.31	\$1.05	\$1.05	\$1.01		
High Growth & Low Prices	2023-2024	Apr	\$0.62	\$0.62	\$0.97	\$0.64	\$0.97	\$0.64	\$0.64	\$0.62	\$0.62	\$0.97	\$0.74	\$0.74	\$0.91			
High Growth & Low Prices	2023-2024	May	\$0.61	\$0.61	\$0.95	\$0.63	\$0.95	\$0.63	\$0.63	\$0.63	\$0.61	\$0.61	\$0.95	\$0.72	\$0.72	\$0.69		
High Growth & Low Prices	2023-2024	Jun	\$0.62	\$0.62	\$0.95	\$0.63	\$0.95	\$0.63	\$0.63	\$0.63	\$0.62	\$0.62	\$0.95	\$0.73	\$0.73	\$0.70		
High Growth & Low Prices	2023-2024	Jul	\$0.58	\$0.58	\$0.95	\$0.60	\$0.95	\$0.60	\$0.60	\$0.60	\$0.58	\$0.58	\$0.95	\$0.70	\$0.70	\$0.67		
High Growth & Low Prices	2023-2024	Aug	\$0.58	\$0.58	\$0.95	\$0.59	\$0.95	\$0.59	\$0.59	\$0.59	\$0.58	\$0.58	\$0.95	\$0.70	\$0.70	\$0.67		
High Growth & Low Prices	2023-2024	Sep	\$0.66	\$0.66	\$0.95	\$0.68	\$0.95	\$0.68	\$0.68	\$0.68	\$0.66	\$0.66	\$0.95	\$0.76	\$0.76	\$0.74		
High Growth & Low Prices	2023-2024	Oct	\$0.67	\$0.67	\$0.99	\$0.69	\$0.99	\$0.69	\$0.69	\$0.69	\$0.67	\$0.67	\$0.99	\$0.78	\$0.78	\$0.75		
High Growth & Low Prices	2024-2025	Nov	\$0.98	\$0.79	\$1.50	\$0.81	\$1.50	\$0.81	\$0.81	\$0.81	\$0.98	\$0.79	\$1.50	\$1.09	\$1.09	\$0.95		
High Growth & Low Prices	2024-2025	Dec	\$1.48	\$0.99	\$1.51	\$1.54	\$1.61	\$1.54	\$1.54	\$1.54	\$1.48	\$0.99	\$1.51	\$1.33	\$1.33	\$1.55		
High Growth & Low Prices	2024-2025	Jan	\$1.53	\$1.16	\$1.53	\$1.19	\$1.75	\$1.19	\$1.19	\$1.19	\$1.53	\$1.16	\$1.53	\$1.41	\$1.41	\$1.30		
High Growth & Low Prices	2024-2025	Feb	\$1.57	\$1.07	\$1.57	\$1.10	\$1.57	\$1.10	\$1.10	\$1.10	\$1.57	\$1.07	\$1.57	\$1.40	\$1.40	\$1.20		
High Growth & Low Prices	2024-2025	Mar	\$0.98	\$0.94	\$1.46	\$0.96	\$1.46	\$0.96	\$0.96	\$0.96	\$0.98	\$0.94	\$1.46	\$1.12	\$1.12	\$1.06		
High Growth & Low Prices	2024-2025	Apr	\$0.79	\$0.79	\$1.22	\$0.81	\$1.22	\$1.22	\$1.22	\$1.22	\$0.79	\$0.79	\$1.22	\$0.94	\$0.94	\$1.14		
High Growth & Low Prices	2024-2025	May	\$0.88	\$0.88	\$1.13	\$0.90	\$1.13	\$0.90	\$0.90	\$0.90	\$0.88	\$0.88	\$1.13	\$0.96	\$0.96	\$0.95		
High Growth & Low Prices	2024-2025	Jun	\$0.80	\$0.80	\$1.13	\$0.82	\$1.13	\$0.82	\$0.82	\$0.82	\$0.80	\$0.80	\$1.13	\$0.91	\$0.91	\$0.88		
High Growth & Low Prices	2024-2025	Jul	\$0.78	\$0.78	\$1.13	\$0.81	\$1.13	\$0.81	\$0.81	\$0.81	\$0.78	\$0.78	\$1.13	\$0.90	\$0.90	\$0.87		
High Growth & Low Prices	2024-2025	Aug	\$0.78	\$0.78	\$1.14	\$0.80	\$1.14	\$0.80	\$0.80	\$0.80	\$0.78	\$0.78	\$1.14	\$0.90	\$0.90	\$0.87		
High Growth & Low Prices	2024-2025	Sep	\$0.88	\$0.88	\$1.14	\$0.90	\$1.14	\$0.90	\$0.90	\$0.90	\$0.88	\$0.88	\$1.14	\$0.97	\$0.97	\$0.95		
High Growth & Low Prices	2024-2025	Oct	\$0.88	\$0.88	\$1.48	\$0.90	\$1.48	\$1.48	\$1.48	\$1.48	\$0.88	\$0.88	\$1.48	\$1.08	\$1.08	\$1.36		
High Growth & Low Prices	2025-2026	Nov	\$1.25	\$1.06	\$1.76	\$1.09	\$1.76	\$1.09	\$1.09	\$1.09	\$1.25	\$1.06	\$1.76	\$1.36	\$1.36	\$1.22		
High Growth & Low Prices	2025-2026	Dec	\$1.70	\$1.20	\$1.77	\$1.82	\$1.86	\$1.82	\$1.82	\$1.82	\$1.70</							

Scenario	Gas Year	Month	Monthly Avoided Costs ¹														
			Nominal \$														
			ID Both	ID GTN	ID NWP	Klamath Falls	La Grande	Medford GTN	Medford NWP	Roseburg	WA Both	WAGTN	WANWP	Idaho	Washington	Oregon	
High Growth & Low Prices	2027-2028	Dec	\$1.99	\$1.52	\$1.99	\$2.07	\$2.26	\$2.07	\$2.07	\$2.07	\$1.99	\$1.52	\$1.99	\$1.84	\$1.84	\$2.11	
High Growth & Low Prices	2027-2028	Jan	\$1.99	\$1.57	\$1.99	\$1.61	\$2.35	\$1.61	\$1.61	\$1.61	\$1.99	\$1.57	\$1.99	\$1.85	\$1.85	\$1.76	
High Growth & Low Prices	2027-2028	Feb	\$1.98	\$1.48	\$2.00	\$1.53	\$2.01	\$1.53	\$1.53	\$1.53	\$1.98	\$1.48	\$2.00	\$1.82	\$1.82	\$1.62	
High Growth & Low Prices	2027-2028	Mar	\$1.41	\$1.35	\$1.94	\$1.38	\$1.94	\$1.38	\$1.38	\$1.38	\$1.41	\$1.35	\$1.94	\$1.57	\$1.57	\$1.49	
High Growth & Low Prices	2027-2028	Apr	\$1.11	\$1.11	\$1.48	\$1.14	\$1.48	\$1.14	\$1.14	\$1.11	\$1.11	\$1.48	\$1.23	\$1.23	\$1.41	\$1.41	
High Growth & Low Prices	2027-2028	May	\$1.20	\$1.20	\$1.48	\$1.23	\$1.48	\$1.23	\$1.23	\$1.23	\$1.20	\$1.20	\$1.48	\$1.29	\$1.29	\$1.28	
High Growth & Low Prices	2027-2028	Jun	\$1.18	\$1.18	\$1.48	\$1.21	\$1.48	\$1.21	\$1.21	\$1.21	\$1.18	\$1.18	\$1.48	\$1.28	\$1.28	\$1.26	
High Growth & Low Prices	2027-2028	Jul	\$1.15	\$1.15	\$1.48	\$1.18	\$1.48	\$1.18	\$1.18	\$1.18	\$1.15	\$1.15	\$1.48	\$1.26	\$1.26	\$1.24	
High Growth & Low Prices	2027-2028	Aug	\$1.17	\$1.17	\$1.48	\$1.20	\$1.48	\$1.20	\$1.20	\$1.20	\$1.17	\$1.17	\$1.48	\$1.27	\$1.27	\$1.26	
High Growth & Low Prices	2027-2028	Sep	\$1.24	\$1.24	\$1.48	\$1.26	\$1.48	\$1.26	\$1.26	\$1.26	\$1.24	\$1.24	\$1.48	\$1.32	\$1.32	\$1.31	
High Growth & Low Prices	2027-2028	Oct	\$1.30	\$1.30	\$2.08	\$1.33	\$2.08	\$1.33	\$1.33	\$1.30	\$1.30	\$2.08	\$1.56	\$1.56	\$1.93	\$1.93	
High Growth & Low Prices	2028-2029	Nov	\$1.87	\$1.54	\$2.00	\$1.58	\$2.00	\$1.58	\$1.58	\$1.58	\$1.87	\$1.54	\$2.00	\$1.80	\$1.80	\$1.66	
High Growth & Low Prices	2028-2029	Dec	\$2.03	\$1.56	\$2.03	\$2.25	\$2.03	\$2.25	\$2.03	\$2.03	\$1.56	\$2.03	\$1.87	\$1.87	\$2.30	\$2.30	
High Growth & Low Prices	2028-2029	Jan	\$2.03	\$1.66	\$2.03	\$1.70	\$2.49	\$1.70	\$1.70	\$1.70	\$2.03	\$1.66	\$2.03	\$1.91	\$1.91	\$1.86	
High Growth & Low Prices	2028-2029	Feb	\$2.04	\$1.57	\$2.04	\$1.61	\$2.05	\$1.61	\$1.61	\$1.61	\$2.04	\$1.57	\$2.04	\$1.88	\$1.88	\$1.69	
High Growth & Low Prices	2028-2029	Mar	\$1.46	\$1.40	\$2.00	\$1.43	\$2.00	\$1.43	\$1.43	\$1.43	\$1.46	\$1.40	\$2.00	\$1.62	\$1.62	\$1.54	
High Growth & Low Prices	2028-2029	Apr	\$1.23	\$1.23	\$1.82	\$1.26	\$1.82	\$1.26	\$1.26	\$1.23	\$1.23	\$1.82	\$1.42	\$1.42	\$1.71	\$1.71	
High Growth & Low Prices	2028-2029	May	\$1.27	\$1.27	\$1.51	\$1.30	\$1.51	\$1.30	\$1.30	\$1.27	\$1.27	\$1.51	\$1.35	\$1.35	\$1.34	\$1.34	
High Growth & Low Prices	2028-2029	Jun	\$1.25	\$1.25	\$1.51	\$1.28	\$1.51	\$1.28	\$1.28	\$1.25	\$1.25	\$1.51	\$1.34	\$1.34	\$1.33	\$1.33	
High Growth & Low Prices	2028-2029	Jul	\$1.21	\$1.21	\$1.51	\$1.24	\$1.51	\$1.24	\$1.24	\$1.21	\$1.21	\$1.51	\$1.31	\$1.31	\$1.30	\$1.30	
High Growth & Low Prices	2028-2029	Aug	\$1.20	\$1.20	\$1.52	\$1.23	\$1.52	\$1.23	\$1.23	\$1.23	\$1.20	\$1.20	\$1.52	\$1.31	\$1.31	\$1.29	
High Growth & Low Prices	2028-2029	Sep	\$1.28	\$1.28	\$1.52	\$1.31	\$1.52	\$1.31	\$1.31	\$1.31	\$1.28	\$1.28	\$1.52	\$1.36	\$1.36	\$1.35	
High Growth & Low Prices	2028-2029	Oct	\$1.33	\$1.33	\$2.11	\$1.36	\$2.11	\$1.36	\$1.36	\$1.33	\$1.33	\$2.11	\$1.59	\$1.59	\$1.96	\$1.96	
High Growth & Low Prices	2029-2030	Nov	\$1.93	\$1.60	\$2.12	\$1.64	\$2.12	\$1.64	\$1.64	\$1.64	\$1.93	\$1.60	\$2.12	\$1.89	\$1.89	\$1.74	
High Growth & Low Prices	2029-2030	Dec	\$2.14	\$1.67	\$2.15	\$2.40	\$2.63	\$2.40	\$2.40	\$2.40	\$2.14	\$1.67	\$2.15	\$1.98	\$1.98	\$2.44	
High Growth & Low Prices	2029-2030	Jan	\$2.16	\$1.70	\$2.16	\$1.73	\$2.64	\$1.73	\$1.73	\$1.73	\$2.16	\$1.70	\$2.16	\$2.01	\$2.01	\$1.92	
High Growth & Low Prices	2029-2030	Feb	\$2.09	\$1.61	\$2.16	\$1.65	\$2.19	\$1.65	\$1.65	\$2.09	\$1.61	\$2.16	\$1.96	\$1.96	\$1.76	\$1.76	
High Growth & Low Prices	2029-2030	Mar	\$1.52	\$1.46	\$2.10	\$1.50	\$2.10	\$1.50	\$1.50	\$1.52	\$1.46	\$2.10	\$1.70	\$1.70	\$1.62	\$1.62	
High Growth & Low Prices	2029-2030	Apr	\$1.29	\$1.29	\$1.91	\$1.32	\$1.91	\$1.32	\$1.32	\$1.29	\$1.29	\$1.91	\$1.50	\$1.50	\$1.79	\$1.79	
High Growth & Low Prices	2029-2030	May	\$1.32	\$1.32	\$1.78	\$1.35	\$1.78	\$1.35	\$1.35	\$1.32	\$1.32	\$1.78	\$1.47	\$1.47	\$1.43	\$1.43	
High Growth & Low Prices	2029-2030	Jun	\$1.28	\$1.28	\$1.78	\$1.31	\$1.78	\$1.31	\$1.31	\$1.31	\$1.28	\$1.28	\$1.78	\$1.45	\$1.45	\$1.41	
High Growth & Low Prices	2029-2030	Jul	\$1.20	\$1.20	\$1.78	\$1.22	\$1.78	\$1.22	\$1.22	\$1.22	\$1.20	\$1.20	\$1.78	\$1.39	\$1.39	\$1.34	
High Growth & Low Prices	2029-2030	Aug	\$1.21	\$1.21	\$1.78	\$1.23	\$1.78	\$1.23	\$1.23	\$1.23	\$1.21	\$1.21	\$1.78	\$1.40	\$1.40	\$1.34	
High Growth & Low Prices	2029-2030	Sep	\$1.26	\$1.26	\$1.78	\$1.29	\$1.78	\$1.29	\$1.29	\$1.29	\$1.26	\$1.26	\$1.78	\$1.44	\$1.44	\$1.39	
High Growth & Low Prices	2029-2030	Oct	\$1.37	\$1.37	\$1.99	\$1.40	\$1.99	\$1.40	\$1.40	\$1.37	\$1.37	\$1.99	\$1.58	\$1.58	\$1.87	\$1.87	
High Growth & Low Prices	2030-2031	Nov	\$1.97	\$1.64	\$2.15	\$1.68	\$2.15	\$1.68	\$1.68	\$1.68	\$1.97	\$1.64	\$2.15	\$1.92	\$1.92	\$1.77	
High Growth & Low Prices	2030-2031	Dec	\$2.19	\$1.72	\$2.19	\$2.41	\$2.65	\$2.41	\$2.41	\$2.41	\$2.19	\$1.72	\$2.19	\$2.03	\$2.03	\$2.46	
High Growth & Low Prices	2030-2031	Jan	\$2.19	\$1.73	\$2.19	\$2.36	\$2.68	\$2.36	\$2.36	\$2.36	\$2.19	\$1.73	\$2.19	\$2.04	\$2.04	\$2.43	
High Growth & Low Prices	2030-2031	Feb	\$2.15	\$1.67	\$2.20	\$1.71	\$2.33	\$1.71	\$1.71	\$1.71	\$2.15	\$1.67	\$2.20	\$2.01	\$2.01	\$1.84	
High Growth & Low Prices	2030-2031	Mar	\$1.58	\$1.49	\$2.12	\$1.53	\$2.12	\$1.53	\$1.53	\$1.53	\$1.58	\$1.49	\$2.12	\$1.73	\$1.73	\$1.64	
High Growth & Low Prices	2030-2031	Apr	\$1.35	\$1.35	\$2.01	\$1.38	\$2.01	\$1.38	\$1.38	\$1.35	\$1.35	\$2.01	\$1.57	\$1.57	\$1.88	\$1.88	
High Growth & Low Prices	2030-2031	May	\$1.35	\$1.35	\$1.81	\$1.38	\$1.81	\$1.38	\$1.38	\$1.35	\$1.35	\$1.81	\$1.50	\$1.50	\$1.46	\$1.46	
High Growth & Low Prices	2030-2031	Jun	\$1.31	\$1.31	\$1.81	\$1.34	\$1.81	\$1.34	\$1.34	\$1.31	\$1.31	\$1.81	\$1.47	\$1.47	\$1.43	\$1.43	
High Growth & Low Prices	2030-2031	Jul	\$1.24	\$1.24	\$1.81	\$1.26	\$1.81	\$1.26	\$1.26	\$1.26	\$1.24	\$1.24	\$1.81	\$1.43	\$1.43	\$1.37	
High Growth & Low Prices	2030-2031	Aug	\$1.23	\$1.23	\$1.81	\$1.26	\$1.81	\$1.26	\$1.26	\$1.26	\$1.23	\$1.23	\$1.81	\$1.42	\$1.42	\$1.37	
High Growth & Low Prices	2030-2031	Sep	\$1.34	\$1.34	\$1.81	\$1.37	\$1.81	\$1.37	\$1.37	\$1.37	\$1.34	\$1.34	\$1.81	\$1.50	\$1.50	\$1.46	
High Growth & Low Prices	2030-2031	Oct	\$1.40	\$1.40	\$2.04	\$1.43	\$2.04	\$1.43	\$1.43	\$1.40	\$1.40	\$2.04	\$1.61	\$1.61	\$1.92	\$1.92	
High Growth & Low Prices	2031-2032	Nov	\$2.08	\$1.70	\$2.30	\$1.80	\$2.30	\$1.80	\$1.80	\$1.80	\$2.08	\$1.70	\$2.30	\$2.03	\$2.03	\$1.90	\$1.90
High Growth & Low Prices	2031-2032	Dec	\$2.22	\$1.73	\$2.34	\$2.53	\$2.77	\$2.53	\$2.53	\$2.53	\$2.22	\$1.73	\$2.34	\$2.09	\$2.09	\$2.58	\$2.58
High Growth & Low Prices	2031-2032	Jan	\$2.20	\$1.74	\$2.33	\$2.48	\$2.80	\$2.48	\$2.48	\$2.48	\$2.20	\$1.74	\$2.33	\$2.09	\$2.09	\$2.55	\$2.55
High Growth & Low Prices	2031-2032	Feb	\$2.17	\$1.67	\$2.35	\$1.71	\$2.46	\$1.71	\$1.71	\$1.71	\$2.17	\$1.67	\$2.35	\$2.06	\$2.06	\$1.86	\$1.86
High Growth & Low Prices	2031-2032	Mar	\$1.60	\$1.51	\$2.25	\$1.54	\$2.25	\$1.54	\$1.54	\$1.54	\$1.60	\$1.51	\$2.25	\$1.79	\$1.79	\$1.69	\$1.69
High Growth & Low Prices	2031-2032	Apr	\$1.39	\$1.39	\$2.07	\$1.42	\$2.07	\$1.42	\$1.42	\$1.39	\$1.39	\$2.07	\$1.62	\$1.62	\$1.94	\$1.94	
High Growth & Low Prices	2031-2032	May	\$1.37	\$1.37	\$2.01	\$1.40	\$2.01	\$1.40	\$1.40	\$1.37	\$1.37	\$2.01	\$1.58	\$1.58	\$1.52	\$1.52	
High Growth & Low Prices	2031-2032	Jun	\$1.30	\$1.30	\$2.01	\$1.33	\$2.01	\$1.33	\$1.33	\$1.33	\$1.30	\$1.30	\$2.01	\$1.54	\$1.54	\$1.47	\$1.47
High Growth & Low Prices	2031-2032	Jul	\$1.09	\$1.09	\$2.01	\$1.11	\$2.01	\$1.11	\$1.11	\$1.11	\$1.09	\$1.09	\$2.01	\$1.39	\$1.39	\$1.29	\$1.29
High Growth & Low Prices	2031-2032	Aug	\$1.09	\$1.09	\$2.01	\$1.11	\$2.01	\$1.11	\$1.11	\$1.11	\$1.09	\$1.09	\$2.01	\$1.40	\$1.40	\$1.29	\$1.29
High Growth & Low Prices	2031-2032	Sep	\$1.28	\$1.28	\$2.01	\$1.31	\$2.01	\$1.31	\$1.31	\$1.31	\$1.28	\$1.28	\$2.01	\$1.53	\$1.53	\$1.45	\$1.45
High Growth & Low Prices	2031-2032	Oct	\$1.39	\$1.39	\$2.04	\$1.42	\$2.04	\$1.42	\$1.42	\$1.39	\$1.39	\$2.04	\$1.60	\$1.60	\$1.91	\$1.91	
High Growth & Low Prices	2032-2033	Nov	\$2.09	\$1.72	\$2.44	\$1.82	\$2.44	\$1.82	\$1.82	\$1.82	\$2.09	\$1.72	\$2.44	\$2.08	\$2.08	\$1.95	\$1.95
High Growth & Low Prices	2032-2033	Dec	\$2.29	\$1.79	\$2.48	\$2.61	\$2.85	\$2.61	\$2.61	\$2.61	\$2.29	\$1.79	\$2.48	\$2.18	\$2.18	\$2.66	\$2.66
High Growth & Low Prices	2032-2033	Jan	\$2.30	\$1.84	\$2.47	\$2.56	\$2.91	\$2.56	\$2.56	\$2.56	\$2.30	\$1.84	\$2.47	\$2.20	\$2.20	\$2.63	\$2.63
High Growth & Low Prices	2032-2033	Feb	\$2.33	\$1.85	\$2.49	\$1.90	\$2.71	\$1.90	\$1.90	\$1.90	\$2.33	\$1.85	\$2.49	\$2.22	\$2.22	\$2.06	\$2.06
High Growth & Low Prices	2032-2033	Mar	\$1.83	\$1.68	\$2.39	\$1.72	\$2.39	\$1.72	\$1.72	\$1.72	\$1.83	\$1.68	\$2.39	\$1.97	\$1.97	\$1.85	\$1.85
High Growth & Low Prices	2032-2033	Apr	\$1.56	\$1.56	\$2.21	\$1.59	\$2.21	\$1.59	\$1.59	\$1.56	\$1.56	\$2.21	\$1.77	\$1.77	\$2.08	\$2.08	
High Growth & Low Prices	2032-2033	May	\$1.52	\$1.52	\$2.21	\$1.56	\$2.21	\$1.56	\$1.56	\$1.52	\$1.52	\$2.21	\$1.75	\$1.75	\$1.69	\$1.69	
High Growth & Low Prices	2032-2033	Jun	\$1.52	\$1.52	\$2.21	\$1.55	\$2.21	\$1.55	\$1.55	\$1.52	\$1.52	\$2.21	\$1.75	\$1.75	\$1.69	\$1.69	
High Growth & Low Prices	2032-2033	Jul	\$1.34	\$1.34	\$2.21	\$1.37	\$2.21	\$1.37	\$1.37	\$1.37	\$1.34	\$1.34	\$2.21	\$1.63	\$1.63	\$1.54	\$1.54
High Growth & Low Prices	2032-2033	Aug	\$1.36	\$1.36	\$2.21	\$1.39	\$2.21	\$1.39	\$1.39	\$1.36	\$1.36	\$2.21	\$1.64	\$1.64	\$1.55	\$1.55	
High Growth & Low Prices	2032-2033	Sep	\$1.50	\$1.50	\$2.21	\$1.53	\$2.21	\$1.53	\$1.53	\$1.50	\$1.50	\$2.21	\$1.74	\$1.74	\$1.67	\$1.67	
High Growth & Low Prices	2032-2033	Oct	\$1.58	\$1.58	\$2.21	\$1.61	\$2.21	\$1.61	\$1.61	\$1.58	\$1.58	\$2.21	\$1.79	\$1.79	\$2.09	\$2.09	
High Growth & Low Prices	2033-2034	Nov	\$2.35	\$1.94	\$2.65	\$2.04	\$2.65	\$2.04	\$2.04	\$2.04	\$2.35	\$1.94	\$2.65	\$2.31	\$2.31	\$2.16	\$2.16
High Growth & Low Prices	2033-2034	Dec	\$2.44	\$1.93	\$2.69	\$2.81	\$3.04	\$2.81	\$2.81	\$2.81	\$2.44	\$1.93	\$2.69	\$2.36	\$2.36	\$2.85	\$2.85
High Growth & Low Prices	2033-2034																

Monthly Avoided Costs ¹																
Nominal \$																
Scenario	Gas Year	Month	ID Both	ID GTN	ID NWP	Klamath Falls	La Grande	Medford GTN	Medford NWP	Roseburg	WA Both	WA GTN	WA NWP	Idaho	Washington	Oregon
High Growth & Low Prices	2035-2036	Jan	\$2.55	\$2.10	\$3.00	\$2.96	\$3.25	\$2.96	\$2.96	\$2.96	\$2.55	\$2.10	\$3.00	\$2.55	\$2.55	\$3.02
High Growth & Low Prices	2035-2036	Feb	\$3.88	\$2.12	\$4.27	\$2.16	\$4.39	\$2.16	\$2.16	\$2.16	\$3.88	\$2.12	\$4.27	\$3.42	\$3.42	\$2.61
High Growth & Low Prices	2035-2036	Mar	\$2.09	\$1.92	\$2.73	\$1.96	\$2.73	\$1.96	\$1.96	\$1.96	\$2.09	\$1.92	\$2.73	\$2.24	\$2.24	\$2.12
High Growth & Low Prices	2035-2036	Apr	\$1.72	\$1.72	\$2.27	\$1.75	\$2.27	\$2.27	\$2.27	\$2.27	\$1.72	\$1.72	\$2.27	\$1.90	\$1.90	\$2.16
High Growth & Low Prices	2035-2036	May	\$1.72	\$1.72	\$2.27	\$1.75	\$2.27	\$1.75	\$1.75	\$1.75	\$1.72	\$1.72	\$2.27	\$1.90	\$1.90	\$1.86
High Growth & Low Prices	2035-2036	Jun	\$1.67	\$1.67	\$2.27	\$1.71	\$2.27	\$1.71	\$1.71	\$1.71	\$1.67	\$1.67	\$2.27	\$1.87	\$1.87	\$1.82
High Growth & Low Prices	2035-2036	Jul	\$1.40	\$1.40	\$2.27	\$1.43	\$2.27	\$1.43	\$1.43	\$1.43	\$1.40	\$1.40	\$2.27	\$1.69	\$1.69	\$1.60
High Growth & Low Prices	2035-2036	Aug	\$1.44	\$1.44	\$2.27	\$1.47	\$2.27	\$1.47	\$1.47	\$1.47	\$1.44	\$1.44	\$2.27	\$1.71	\$1.71	\$1.63
High Growth & Low Prices	2035-2036	Sep	\$1.60	\$1.60	\$2.27	\$1.64	\$2.27	\$1.64	\$1.64	\$1.64	\$1.60	\$1.60	\$2.27	\$1.82	\$1.82	\$1.76
High Growth & Low Prices	2035-2036	Oct	\$1.77	\$1.77	\$2.34	\$1.80	\$2.34	\$2.34	\$2.34	\$2.34	\$1.77	\$1.77	\$2.34	\$1.96	\$1.96	\$2.23
High Growth & Low Prices	2036-2037	Nov	\$2.57	\$2.11	\$3.14	\$2.25	\$3.14	\$2.25	\$2.25	\$2.25	\$2.57	\$2.11	\$3.14	\$2.61	\$2.61	\$2.43
High Growth & Low Prices	2036-2037	Dec	\$2.70	\$2.15	\$3.19	\$3.17	\$3.39	\$3.17	\$3.17	\$3.17	\$2.70	\$2.15	\$3.19	\$2.68	\$2.68	\$3.22
High Growth & Low Prices	2036-2037	Jan	\$2.62	\$2.17	\$3.19	\$3.14	\$3.42	\$3.14	\$3.14	\$3.14	\$2.62	\$2.17	\$3.19	\$2.66	\$2.66	\$3.20
High Growth & Low Prices	2036-2037	Feb	\$3.85	\$2.06	\$4.49	\$2.11	\$4.61	\$2.11	\$2.11	\$2.11	\$3.85	\$2.06	\$4.49	\$3.47	\$3.47	\$2.61
High Growth & Low Prices	2036-2037	Mar	\$2.03	\$1.87	\$2.78	\$1.91	\$2.78	\$1.91	\$1.91	\$1.91	\$2.03	\$1.87	\$2.78	\$2.23	\$2.23	\$2.08
High Growth & Low Prices	2036-2037	Apr	\$1.67	\$1.67	\$2.24	\$1.71	\$2.24	\$2.24	\$2.24	\$2.24	\$1.67	\$1.67	\$2.24	\$1.86	\$1.86	\$2.13
High Growth & Low Prices	2036-2037	May	\$1.80	\$1.80	\$2.24	\$1.84	\$2.24	\$1.84	\$1.84	\$1.84	\$1.80	\$1.80	\$2.24	\$1.95	\$1.95	\$1.92
High Growth & Low Prices	2036-2037	Jun	\$1.77	\$1.77	\$2.24	\$1.80	\$2.24	\$1.80	\$1.80	\$1.80	\$1.77	\$1.77	\$2.24	\$1.93	\$1.93	\$1.89
High Growth & Low Prices	2036-2037	Jul	\$1.54	\$1.54	\$2.24	\$1.58	\$2.24	\$1.58	\$1.58	\$1.58	\$1.54	\$1.54	\$2.24	\$1.78	\$1.78	\$1.71
High Growth & Low Prices	2036-2037	Aug	\$1.61	\$1.61	\$2.24	\$1.64	\$2.24	\$1.64	\$1.64	\$1.64	\$1.61	\$1.61	\$2.24	\$1.82	\$1.82	\$1.76
High Growth & Low Prices	2036-2037	Sep	\$1.74	\$1.74	\$2.25	\$1.78	\$2.25	\$1.78	\$1.78	\$1.78	\$1.74	\$1.74	\$2.25	\$1.91	\$1.91	\$1.87
High Growth & Low Prices	2036-2037	Oct	\$1.89	\$1.89	\$2.45	\$1.93	\$2.45	\$2.45	\$2.45	\$2.45	\$1.89	\$1.89	\$2.45	\$2.07	\$2.07	\$2.35
High Growth & Low Prices	2037-2038	Nov	\$2.73	\$2.28	\$3.28	\$2.51	\$3.28	\$2.51	\$2.51	\$2.51	\$2.73	\$2.28	\$3.28	\$2.76	\$2.76	\$2.67
High Growth & Low Prices	2037-2038	Dec	\$2.91	\$2.38	\$3.32	\$3.30	\$3.54	\$3.30	\$3.30	\$3.30	\$2.91	\$2.38	\$3.32	\$2.87	\$2.87	\$3.35
High Growth & Low Prices	2037-2038	Jan	\$2.85	\$2.40	\$3.32	\$3.27	\$3.57	\$3.27	\$3.27	\$3.27	\$2.85	\$2.40	\$3.32	\$2.86	\$2.86	\$3.33
High Growth & Low Prices	2037-2038	Feb	\$4.01	\$2.23	\$4.63	\$2.28	\$4.69	\$2.28	\$2.28	\$2.28	\$4.01	\$2.23	\$4.63	\$3.62	\$3.62	\$2.76
High Growth & Low Prices	2037-2038	Mar	\$2.21	\$2.01	\$2.90	\$2.05	\$2.90	\$2.05	\$2.05	\$2.05	\$2.21	\$2.01	\$2.90	\$2.38	\$2.38	\$2.22
High Growth & Low Prices	2037-2038	Apr	\$1.84	\$1.84	\$2.38	\$1.88	\$2.38	\$2.38	\$2.38	\$2.38	\$1.84	\$1.84	\$2.38	\$2.02	\$2.02	\$2.28
High Growth & Low Prices	2037-2038	May	\$1.87	\$1.87	\$2.38	\$1.90	\$2.38	\$1.90	\$1.90	\$1.90	\$1.87	\$1.87	\$2.38	\$2.04	\$2.04	\$2.00
High Growth & Low Prices	2037-2038	Jun	\$1.86	\$1.86	\$2.38	\$1.90	\$2.38	\$1.90	\$1.90	\$1.90	\$1.86	\$1.86	\$2.38	\$2.04	\$2.04	\$2.00
High Growth & Low Prices	2037-2038	Jul	\$1.62	\$1.62	\$2.38	\$1.65	\$2.38	\$1.65	\$1.65	\$1.65	\$1.62	\$1.62	\$2.38	\$1.87	\$1.87	\$1.80
High Growth & Low Prices	2037-2038	Aug	\$1.62	\$1.62	\$2.38	\$1.65	\$2.38	\$1.65	\$1.65	\$1.65	\$1.62	\$1.62	\$2.38	\$1.87	\$1.87	\$1.80
High Growth & Low Prices	2037-2038	Sep	\$1.73	\$1.73	\$2.39	\$1.77	\$2.39	\$1.77	\$1.77	\$1.77	\$1.73	\$1.73	\$2.39	\$1.95	\$1.95	\$1.89
High Growth & Low Prices	2037-2038	Oct	\$1.86	\$1.86	\$2.42	\$1.90	\$2.42	\$2.42	\$2.42	\$2.42	\$1.86	\$1.86	\$2.42	\$2.05	\$2.05	\$2.31
High Growth & Low Prices	2038-2039	Nov	\$2.68	\$2.23	\$3.34	\$2.49	\$3.34	\$2.49	\$2.49	\$2.49	\$2.68	\$2.23	\$3.34	\$2.75	\$2.75	\$2.66
High Growth & Low Prices	2038-2039	Dec	\$2.91	\$2.34	\$3.39	\$3.36	\$3.58	\$3.36	\$3.36	\$3.36	\$2.91	\$2.34	\$3.39	\$2.88	\$2.88	\$3.40
High Growth & Low Prices	2038-2039	Jan	\$2.91	\$2.39	\$3.39	\$3.34	\$3.64	\$3.34	\$3.34	\$3.34	\$2.91	\$2.39	\$3.39	\$2.90	\$2.90	\$3.40
High Growth & Low Prices	2038-2039	Feb	\$4.06	\$2.27	\$4.69	\$2.32	\$4.74	\$2.32	\$2.32	\$2.32	\$4.06	\$2.27	\$4.69	\$3.67	\$3.67	\$2.81
High Growth & Low Prices	2038-2039	Mar	\$2.35	\$2.15	\$3.04	\$2.19	\$3.04	\$2.19	\$2.19	\$2.19	\$2.35	\$2.15	\$3.04	\$2.51	\$2.51	\$2.36
High Growth & Low Prices	2038-2039	Apr	\$1.96	\$1.96	\$2.50	\$2.00	\$2.50	\$2.50	\$2.50	\$2.50	\$1.96	\$1.96	\$2.50	\$2.14	\$2.14	\$2.40
High Growth & Low Prices	2038-2039	May	\$1.99	\$1.99	\$2.50	\$2.03	\$2.50	\$2.03	\$2.03	\$2.03	\$1.99	\$1.99	\$2.50	\$2.16	\$2.16	\$2.12
High Growth & Low Prices	2038-2039	Jun	\$1.89	\$1.89	\$2.50	\$1.93	\$2.50	\$1.93	\$1.93	\$1.93	\$1.89	\$1.89	\$2.50	\$2.09	\$2.09	\$2.04
High Growth & Low Prices	2038-2039	Jul	\$1.68	\$1.68	\$2.50	\$1.72	\$2.50	\$1.72	\$1.72	\$1.72	\$1.68	\$1.68	\$2.50	\$1.96	\$1.96	\$1.88
High Growth & Low Prices	2038-2039	Aug	\$1.67	\$1.67	\$2.50	\$1.71	\$2.50	\$1.71	\$1.71	\$1.71	\$1.67	\$1.67	\$2.50	\$1.95	\$1.95	\$1.87
High Growth & Low Prices	2038-2039	Sep	\$1.86	\$1.86	\$2.50	\$1.90	\$2.50	\$1.90	\$1.90	\$1.90	\$1.86	\$1.86	\$2.50	\$2.08	\$2.08	\$2.02
High Growth & Low Prices	2038-2039	Oct	\$2.01	\$2.01	\$2.57	\$2.05	\$2.57	\$2.57	\$2.57	\$2.57	\$2.01	\$2.01	\$2.57	\$2.20	\$2.20	\$2.47
High Growth & Low Prices	2039-2040	Nov	\$2.88	\$2.43	\$3.52	\$2.69	\$3.53	\$2.69	\$2.69	\$2.69	\$2.88	\$2.43	\$3.52	\$2.95	\$2.95	\$2.85
High Growth & Low Prices	2039-2040	Dec	\$3.08	\$2.50	\$3.58	\$3.54	\$3.82	\$3.55	\$3.55	\$3.55	\$3.08	\$2.50	\$3.58	\$3.05	\$3.05	\$3.60
High Growth & Low Prices	2039-2040	Jan	\$3.03	\$2.50	\$3.57	\$3.51	\$3.77	\$3.51	\$3.51	\$3.51	\$3.03	\$2.50	\$3.57	\$3.03	\$3.03	\$3.57
High Growth & Low Prices	2039-2040	Feb	\$4.18	\$2.42	\$4.80	\$2.48	\$4.80	\$2.48	\$2.48	\$2.48	\$4.18	\$2.42	\$4.80	\$3.80	\$3.80	\$2.94
High Growth & Low Prices	2039-2040	Mar	\$2.46	\$2.25	\$3.20	\$2.30	\$3.20	\$2.30	\$2.30	\$2.30	\$2.46	\$2.25	\$3.20	\$2.64	\$2.64	\$2.48
High Growth & Low Prices	2039-2040	Apr	\$2.07	\$2.07	\$2.62	\$2.11	\$2.62	\$2.62	\$2.62	\$2.62	\$2.07	\$2.07	\$2.62	\$2.25	\$2.25	\$2.52
High Growth & Low Prices	2039-2040	May	\$2.09	\$2.09	\$2.62	\$2.13	\$2.62	\$2.13	\$2.13	\$2.13	\$2.09	\$2.09	\$2.62	\$2.26	\$2.26	\$2.23
High Growth & Low Prices	2039-2040	Jun	\$2.06	\$2.06	\$2.62	\$2.10	\$2.62	\$2.10	\$2.10	\$2.10	\$2.06	\$2.06	\$2.62	\$2.24	\$2.24	\$2.20
High Growth & Low Prices	2039-2040	Jul	\$1.87	\$1.87	\$2.62	\$1.91	\$2.62	\$1.91	\$1.91	\$1.91	\$1.87	\$1.87	\$2.62	\$2.12	\$2.12	\$2.05
High Growth & Low Prices	2039-2040	Aug	\$1.88	\$1.88	\$2.62	\$1.92	\$2.62	\$1.92	\$1.92	\$1.92	\$1.88	\$1.88	\$2.62	\$2.13	\$2.13	\$2.06
High Growth & Low Prices	2039-2040	Sep	\$2.03	\$2.03	\$2.62	\$2.07	\$2.62	\$2.07	\$2.07	\$2.07	\$2.03	\$2.03	\$2.62	\$2.23	\$2.23	\$2.18
High Growth & Low Prices	2039-2040	Oct	\$2.14	\$2.14	\$2.69	\$2.18	\$2.69	\$2.69	\$2.69	\$2.69	\$2.14	\$2.14	\$2.69	\$2.32	\$2.32	\$2.59

¹Avoided costs are before Environmental Externalities adder

APPENDIX 6.4: AVERAGE CASE MONTHLY DETAIL

Scenario	Gas Year	Month	Monthly Avoided Costs ¹													Idaho	Washington	Oregon
			Nominal \$															
			ID Both	ID GTN	ID NWP	Klamath Falls	La Grande	Medford GTN	Medford NWP	Roseburg	WA Both	WA GTN	WA NWP					
Average Case 2019-2020 Nov	\$1.87	\$2.18	\$1.87	\$2.22	\$2.22	\$2.22	\$2.22	\$2.22	\$1.87	\$1.87	\$1.87	\$1.97	\$1.97	\$2.22				
Average Case 2019-2020 Dec	\$1.87	\$1.87	\$1.87	\$2.02	\$2.05	\$2.02	\$2.02	\$2.02	\$1.87	\$1.87	\$1.87	\$1.87	\$1.87	\$2.02				
Average Case 2019-2020 Jan	\$1.91	\$1.80	\$1.91	\$1.84	\$1.96	\$1.84	\$1.84	\$1.84	\$1.91	\$1.80	\$1.91	\$1.88	\$1.88	\$1.87				
Average Case 2019-2020 Feb	\$1.70	\$1.43	\$1.73	\$1.47	\$1.73	\$1.47	\$1.47	\$1.47	\$1.70	\$1.43	\$1.73	\$1.62	\$1.62	\$1.52				
Average Case 2019-2020 Mar	\$1.25	\$1.25	\$1.38	\$1.28	\$1.38	\$1.28	\$1.28	\$1.28	\$1.25	\$1.25	\$1.38	\$1.30	\$1.30	\$1.30				
Average Case 2019-2020 Apr	\$1.03	\$1.03	\$1.15	\$1.05	\$1.14	\$1.15	\$1.15	\$1.15	\$1.03	\$1.03	\$1.15	\$1.07	\$1.07	\$1.13				
Average Case 2019-2020 May	\$1.05	\$1.14	\$1.05	\$1.07	\$1.05	\$1.05	\$1.05	\$1.05	\$1.05	\$1.14	\$1.05	\$1.08	\$1.08	\$1.06				
Average Case 2019-2020 Jun	\$0.90	\$0.90	\$1.06	\$0.86	\$0.90	\$0.86	\$0.86	\$0.86	\$0.90	\$0.90	\$1.06	\$0.95	\$0.95	\$0.87				
Average Case 2019-2020 Jul	\$0.86	\$0.86	\$1.06	\$0.80	\$0.80	\$0.80	\$0.80	\$0.80	\$0.86	\$0.86	\$1.06	\$0.93	\$0.93	\$0.82				
Average Case 2019-2020 Aug	\$1.10	\$1.10	\$1.11	\$1.13	\$1.11	\$1.11	\$1.11	\$1.11	\$1.10	\$1.10	\$1.11	\$1.11	\$1.11	\$1.12				
Average Case 2019-2020 Sep	\$0.99	\$0.99	\$1.06	\$1.01	\$1.06	\$1.01	\$1.01	\$1.01	\$0.99	\$0.99	\$1.06	\$1.01	\$1.01	\$1.02				
Average Case 2019-2020 Oct	\$1.02	\$1.02	\$1.31	\$1.04	\$1.31	\$1.04	\$1.04	\$1.04	\$1.02	\$1.02	\$1.31	\$1.12	\$1.12	\$1.10				
Average Case 2020-2021 Nov	\$1.81	\$1.81	\$1.82	\$1.74	\$1.82	\$1.74	\$1.74	\$1.74	\$1.81	\$1.81	\$1.82	\$1.81	\$1.81	\$1.75				
Average Case 2020-2021 Dec	\$2.43	\$2.36	\$2.43	\$2.44	\$2.45	\$2.44	\$2.44	\$2.44	\$2.43	\$2.36	\$2.43	\$2.41	\$2.41	\$2.44				
Average Case 2020-2021 Jan	\$2.44	\$2.45	\$2.44	\$2.50	\$2.52	\$2.50	\$2.50	\$2.50	\$2.44	\$2.45	\$2.44	\$2.44	\$2.44	\$2.51				
Average Case 2020-2021 Feb	\$2.43	\$2.33	\$2.43	\$2.38	\$2.43	\$2.38	\$2.38	\$2.38	\$2.43	\$2.33	\$2.43	\$2.40	\$2.40	\$2.39				
Average Case 2020-2021 Mar	\$2.02	\$2.02	\$2.32	\$2.06	\$2.32	\$2.06	\$2.06	\$2.06	\$2.02	\$2.02	\$2.32	\$2.12	\$2.12	\$2.11				
Average Case 2020-2021 Apr	\$1.51	\$1.51	\$1.87	\$1.54	\$1.87	\$1.85	\$1.85	\$1.85	\$1.51	\$1.51	\$1.87	\$1.63	\$1.63	\$1.79				
Average Case 2020-2021 May	\$1.40	\$1.40	\$1.87	\$1.43	\$1.83	\$1.43	\$1.43	\$1.43	\$1.40	\$1.40	\$1.87	\$1.56	\$1.56	\$1.51				
Average Case 2020-2021 Jun	\$1.45	\$1.45	\$1.87	\$1.48	\$1.82	\$1.48	\$1.48	\$1.48	\$1.45	\$1.45	\$1.87	\$1.59	\$1.59	\$1.55				
Average Case 2020-2021 Jul	\$1.58	\$1.58	\$1.87	\$1.62	\$1.87	\$1.62	\$1.62	\$1.62	\$1.58	\$1.58	\$1.87	\$1.68	\$1.68	\$1.67				
Average Case 2020-2021 Aug	\$1.57	\$1.57	\$1.87	\$1.61	\$1.87	\$1.61	\$1.61	\$1.61	\$1.57	\$1.57	\$1.87	\$1.67	\$1.67	\$1.66				
Average Case 2020-2021 Sep	\$1.42	\$1.42	\$1.87	\$1.45	\$1.87	\$1.45	\$1.45	\$1.45	\$1.42	\$1.42	\$1.87	\$1.57	\$1.57	\$1.54				
Average Case 2020-2021 Oct	\$1.45	\$1.45	\$2.05	\$1.48	\$2.05	\$1.48	\$1.48	\$1.48	\$1.45	\$1.45	\$2.05	\$1.65	\$1.65	\$1.60				
Average Case 2021-2022 Nov	\$1.79	\$1.79	\$2.09	\$1.83	\$2.09	\$1.83	\$1.83	\$1.83	\$1.79	\$1.79	\$2.09	\$1.89	\$1.89	\$1.88				
Average Case 2021-2022 Dec	\$2.08	\$2.08	\$2.09	\$2.12	\$2.12	\$2.12	\$2.12	\$2.12	\$2.08	\$2.08	\$2.09	\$2.08	\$2.08	\$2.12				
Average Case 2021-2022 Jan	\$2.13	\$2.19	\$2.13	\$2.24	\$2.24	\$2.24	\$2.24	\$2.24	\$2.13	\$2.19	\$2.13	\$2.15	\$2.15	\$2.24				
Average Case 2021-2022 Feb	\$2.05	\$2.05	\$2.09	\$2.09	\$2.09	\$2.09	\$2.09	\$2.09	\$2.05	\$2.05	\$2.09	\$2.06	\$2.06	\$2.09				
Average Case 2021-2022 Mar	\$1.74	\$1.74	\$2.18	\$1.77	\$2.18	\$1.77	\$1.77	\$1.77	\$1.74	\$1.74	\$2.18	\$1.88	\$1.88	\$1.85				
Average Case 2021-2022 Apr	\$1.11	\$1.11	\$1.69	\$1.13	\$1.69	\$1.13	\$1.13	\$1.13	\$1.11	\$1.11	\$1.69	\$1.30	\$1.30	\$1.53				
Average Case 2021-2022 May	\$1.08	\$1.08	\$1.69	\$1.11	\$1.68	\$1.11	\$1.11	\$1.11	\$1.08	\$1.08	\$1.69	\$1.28	\$1.28	\$1.22				
Average Case 2021-2022 Jun	\$1.18	\$1.18	\$1.69	\$1.21	\$1.69	\$1.21	\$1.21	\$1.21	\$1.18	\$1.18	\$1.69	\$1.35	\$1.35	\$1.31				
Average Case 2021-2022 Jul	\$1.34	\$1.34	\$1.69	\$1.37	\$1.69	\$1.37	\$1.37	\$1.37	\$1.34	\$1.34	\$1.69	\$1.45	\$1.45	\$1.43				
Average Case 2021-2022 Aug	\$1.29	\$1.29	\$1.69	\$1.32	\$1.69	\$1.32	\$1.32	\$1.32	\$1.29	\$1.29	\$1.69	\$1.42	\$1.42	\$1.39				
Average Case 2021-2022 Sep	\$1.11	\$1.11	\$1.69	\$1.13	\$1.69	\$1.13	\$1.13	\$1.13	\$1.11	\$1.11	\$1.69	\$1.30	\$1.30	\$1.24				
Average Case 2021-2022 Oct	\$1.11	\$1.11	\$1.69	\$1.13	\$1.69	\$1.13	\$1.13	\$1.13	\$1.11	\$1.11	\$1.69	\$1.30	\$1.30	\$1.24				
Average Case 2022-2023 Nov	\$1.38	\$1.38	\$1.95	\$1.41	\$1.95	\$1.41	\$1.41	\$1.41	\$1.38	\$1.38	\$1.95	\$1.57	\$1.57	\$1.52				
Average Case 2022-2023 Dec	\$1.90	\$1.89	\$1.95	\$1.93	\$1.95	\$1.93	\$1.93	\$1.93	\$1.90	\$1.89	\$1.95	\$1.91	\$1.91	\$1.94				
Average Case 2022-2023 Jan	\$1.99	\$2.00	\$1.99	\$2.04	\$2.04	\$2.04	\$2.04	\$2.04	\$1.99	\$2.00	\$1.99	\$1.99	\$1.99	\$2.04				
Average Case 2022-2023 Feb	\$1.79	\$1.79	\$1.95	\$1.83	\$1.95	\$1.83	\$1.83	\$1.83	\$1.79	\$1.79	\$1.95	\$1.85	\$1.85	\$1.85				
Average Case 2022-2023 Mar	\$1.53	\$1.53	\$2.01	\$1.56	\$2.01	\$1.56	\$1.56	\$1.56	\$1.53	\$1.53	\$2.01	\$1.69	\$1.69	\$1.65				
Average Case 2022-2023 Apr	\$1.07	\$1.07	\$1.67	\$1.09	\$1.67	\$1.09	\$1.09	\$1.09	\$1.07	\$1.07	\$1.67	\$1.27	\$1.27	\$1.52				
Average Case 2022-2023 May	\$1.03	\$1.03	\$1.67	\$1.06	\$1.67	\$1.06	\$1.06	\$1.06	\$1.03	\$1.03	\$1.67	\$1.25	\$1.25	\$1.17				
Average Case 2022-2023 Jun	\$1.21	\$1.21	\$1.67	\$1.23	\$1.66	\$1.23	\$1.23	\$1.23	\$1.21	\$1.21	\$1.67	\$1.36	\$1.36	\$1.32				
Average Case 2022-2023 Jul	\$1.26	\$1.26	\$1.67	\$1.29	\$1.67	\$1.29	\$1.29	\$1.29	\$1.26	\$1.26	\$1.67	\$1.40	\$1.40	\$1.37				
Average Case 2022-2023 Aug	\$1.27	\$1.27	\$1.67	\$1.30	\$1.67	\$1.30	\$1.30	\$1.30	\$1.27	\$1.27	\$1.67	\$1.40	\$1.40	\$1.37				
Average Case 2022-2023 Sep	\$0.99	\$0.99	\$1.68	\$1.01	\$1.68	\$1.01	\$1.01	\$1.01	\$0.99	\$0.99	\$1.68	\$1.22	\$1.22	\$1.14				
Average Case 2022-2023 Oct	\$1.07	\$1.07	\$1.72	\$1.10	\$1.72	\$1.10	\$1.10	\$1.10	\$1.07	\$1.07	\$1.72	\$1.29	\$1.29	\$1.22				
Average Case 2023-2024 Nov	\$1.60	\$1.60	\$2.03	\$1.63	\$2.03	\$1.63	\$1.63	\$1.63	\$1.60	\$1.60	\$2.03	\$1.74	\$1.74	\$1.71				
Average Case 2023-2024 Dec	\$1.89	\$1.85	\$2.03	\$1.93	\$2.04	\$1.93	\$1.93	\$1.93	\$1.89	\$1.85	\$2.03	\$1.92	\$1.92	\$1.95				
Average Case 2023-2024 Jan	\$2.06	\$2.06	\$2.06	\$2.11	\$2.12	\$2.11	\$2.11	\$2.11	\$2.06	\$2.06	\$2.06	\$2.06	\$2.06	\$2.11				
Average Case 2023-2024 Feb	\$1.76	\$1.76	\$2.03	\$1.79	\$2.03	\$1.79	\$1.79	\$1.79	\$1.76	\$1.76	\$2.03	\$1.85	\$1.85	\$1.84				
Average Case 2023-2024 Mar	\$1.69	\$1.69	\$2.09	\$1.72	\$2.09	\$1.72	\$1.72	\$1.72	\$1.69	\$1.69	\$2.09	\$1.82	\$1.82	\$1.80				
Average Case 2023-2024 Apr	\$1.38	\$1.38	\$1.73	\$1.41	\$1.73	\$1.41	\$1.41	\$1.41	\$1.38	\$1.38	\$1.73	\$1.49	\$1.49	\$1.66				
Average Case 2023-2024 May	\$1.36	\$1.36	\$1.70	\$1.40	\$1.70	\$1.40	\$1.40	\$1.40	\$1.36	\$1.36	\$1.70	\$1.48	\$1.48	\$1.46				
Average Case 2023-2024 Jun	\$1.38	\$1.38	\$1.70	\$1.41	\$1.70	\$1.41	\$1.41	\$1.41	\$1.38	\$1.38	\$1.70	\$1.49	\$1.49	\$1.47				
Average Case 2023-2024 Jul	\$1.35	\$1.35	\$1.70	\$1.38	\$1.70	\$1.38	\$1.38	\$1.38	\$1.35	\$1.35	\$1.70	\$1.47	\$1.47	\$1.45				
Average Case 2023-2024 Aug	\$1.36	\$1.36	\$1.70	\$1.39	\$1.70	\$1.39	\$1.39	\$1.39	\$1.36	\$1.36	\$1.70	\$1.47	\$1.47	\$1.45				
Average Case 2023-2024 Sep	\$1.44	\$1.44	\$1.70	\$1.47	\$1.70	\$1.47	\$1.47	\$1.47	\$1.44	\$1.44	\$1.70	\$1.53	\$1.53	\$1.52				
Average Case 2023-2024 Oct	\$1.45	\$1.45	\$1.76	\$1.48	\$1.76	\$1.48	\$1.48	\$1.48	\$1.45	\$1.45	\$1.76	\$1.56	\$1.56	\$1.54				
Average Case 2024-2025 Nov	\$1.60	\$1.60	\$2.07	\$1.63	\$2.07	\$1.63	\$1.63	\$1.63	\$1.60	\$1.60	\$2.07	\$1.76	\$1.76	\$1.72				
Average Case 2024-2025 Dec	\$1.96	\$1.84	\$2.07	\$1.94	\$2.09	\$1.94	\$1.94	\$1.94	\$1.96	\$1.84	\$2.07	\$1.96	\$1.96	\$1.97				
Average Case 2024-2025 Jan	\$2.11	\$2.11	\$2.11	\$2.15	\$2.17	\$2.15	\$2.15	\$2.15	\$2.11	\$2.11	\$2.11	\$2.11	\$2.11	\$2.16				
Average Case 2024-2025 Feb	\$1.99	\$1.99	\$2.07	\$2.03	\$2.07	\$2.03	\$2.03	\$2.03	\$1.99	\$1.99	\$2.07	\$2.02	\$2.02	\$2.04				
Average Case 2024-2025 Mar	\$1.86	\$1.86	\$2.09	\$1.90	\$2.09	\$1.90	\$1.90	\$1.90	\$1.86	\$1.86	\$2.09	\$1.94	\$1.94	\$1.94				
Average Case 2024-2025 Apr	\$1.68	\$1.68	\$2.11	\$1.72	\$2.11	\$1.72	\$1.72	\$1.72	\$1.68	\$1.68	\$2.11	\$1.82	\$1.82	\$2.03				
Average Case 2024-2025 May	\$1.77	\$1.77	\$2.03	\$1.80	\$2.03	\$1.80	\$1.80	\$1.80	\$1.77	\$1.77	\$2.03	\$1.85	\$1.85	\$1.85				
Average Case 2024-2025 Jun	\$1.69	\$1.69	\$2.03	\$1.73	\$2.03	\$1.73	\$1.73	\$1.73	\$1.69	\$1.69	\$2.03	\$1.80	\$1.80	\$1.79				
Average Case 2024-2025 Jul	\$1.70	\$1.70	\$2.03	\$1.74	\$2.03	\$1.74	\$1.74	\$1.74	\$1.70	\$1.70	\$2.03	\$1.81	\$1.81	\$1.80				
Average Case 2024-2025 Aug	\$1.70	\$1.70	\$2.03	\$1.73	\$2.03	\$1.73	\$1.73	\$1.73	\$1.70	\$1.70	\$2.03	\$1.81	\$1.81	\$1.79				
Average Case 2024-2025 Sep	\$1.79	\$1.79	\$2.03	\$1.82	\$2.03	\$1.82	\$1.82	\$1.82	\$1.79	\$1.79	\$2.03	\$1.87	\$1.87	\$1.87				
Average Case 2024-2025 Oct	\$1.79	\$1.79	\$2.38	\$1.82	\$2.38	\$1.82	\$1.82	\$1.82	\$1.79	\$1.79	\$2.38	\$1.98	\$1.98	\$1.93				
Average Case 2025-2026 Nov	\$2.01	\$2.01	\$2.46	\$2.05	\$2.46	\$2.05	\$2.05	\$2.05	\$2.01	\$2.01	\$2.46	\$2.16	\$2.16	\$2.14				
Average Case 2025-2026 Dec	\$2.32	\$2.17	\$2.46	\$2.30	\$2.48	\$2.30	\$2.30	\$2.30	\$2.32	\$2.17	\$2.46	\$2.32	\$2.32	\$2.34				
Average Case 2025-2026 Jan	\$2.50	\$2.50	\$2.50	\$2.56	\$2.58	\$2.56	\$2.56	\$2.56	\$2.50	\$2.50	\$2.50	\$2.50	\$2.50	\$2.56				
Average Case 2025-2026 Feb	\$2.44	\$2.44	\$2.46	\$2.49	\$2.49	\$2.49	\$2.49	\$2.49	\$2.44	\$2.44	\$2.46	\$2.45	\$2.45	\$2.49				
Average Case 2025-2026 Mar	\$2.30	\$2.30	\$2.49	\$2.35	\$2.49	\$2.35	\$2.35	\$2.35	\$2.30	\$2.30	\$2.49	\$2.36	\$2.36	\$2.38				
Average Case 2025-2026 Apr	\$2.10	\$2.10	\$2.59	\$2.15	\$2.59	\$2.15	\$2.15	\$2.15	\$2.10	\$2.10	\$2.59	\$2.27	\$2.27	\$2.50				
Average Case 2025-2026 May	\$2.13	\$2.13	\$2.36	\$2.17	\$2.36	\$2.17	\$2.17	\$2.17	\$2.13	\$2.13	\$2.36	\$2.21	\$2.21	\$2.21				
Average Case 2025-2026 Jun	\$2.11	\$2.11	\$2.36	\$2.15	\$2.36	\$2.15	\$2.15	\$2.15	\$2.11	\$2.11	\$2.36	\$2.19	\$2.19	\$2.19				
Average Case 2025-2026 Jul	\$2.09	\$2.09	\$2.36	\$2.14	\$2.36	\$2.14	\$2.14	\$2.14	\$									

			Monthly Avoided Costs ¹														
			Nominal \$														
Scenario	Gas Year	Month	ID Both	ID GTN	ID NWP	Klamath Falls	La Grande	Medford GTN	Medford NWP	Roseburg	WA Both	WA GTN	WA NWP	Idaho	Washington	Oregon	
Average Case	2027-2028	Dec	\$2.80	\$2.78	\$2.80	\$2.85	\$2.85	\$2.85	\$2.85	\$2.85	\$2.80	\$2.78	\$2.80	\$2.79	\$2.79	\$2.85	
Average Case	2027-2028	Jan	\$2.85	\$2.85	\$2.85	\$2.91	\$2.91	\$2.91	\$2.91	\$2.91	\$2.85	\$2.85	\$2.85	\$2.85	\$2.85	\$2.91	
Average Case	2027-2028	Feb	\$2.74	\$2.74	\$2.80	\$2.80	\$2.80	\$2.80	\$2.80	\$2.80	\$2.74	\$2.74	\$2.80	\$2.76	\$2.76	\$2.80	
Average Case	2027-2028	Mar	\$2.62	\$2.62	\$2.84	\$2.68	\$2.84	\$2.68	\$2.68	\$2.68	\$2.62	\$2.62	\$2.84	\$2.70	\$2.70	\$2.71	
Average Case	2027-2028	Apr	\$2.33	\$2.33	\$2.69	\$2.38	\$2.69	\$2.69	\$2.69	\$2.69	\$2.33	\$2.33	\$2.69	\$2.45	\$2.45	\$2.63	
Average Case	2027-2028	May	\$2.43	\$2.43	\$2.69	\$2.48	\$2.69	\$2.48	\$2.48	\$2.48	\$2.43	\$2.43	\$2.69	\$2.52	\$2.52	\$2.52	
Average Case	2027-2028	Jun	\$2.41	\$2.41	\$2.69	\$2.46	\$2.69	\$2.46	\$2.46	\$2.46	\$2.41	\$2.41	\$2.69	\$2.50	\$2.50	\$2.50	
Average Case	2027-2028	Jul	\$2.41	\$2.41	\$2.69	\$2.46	\$2.69	\$2.46	\$2.46	\$2.46	\$2.41	\$2.41	\$2.69	\$2.51	\$2.51	\$2.51	
Average Case	2027-2028	Aug	\$2.43	\$2.43	\$2.69	\$2.48	\$2.69	\$2.48	\$2.48	\$2.48	\$2.43	\$2.43	\$2.69	\$2.52	\$2.52	\$2.52	
Average Case	2027-2028	Sep	\$2.48	\$2.48	\$2.69	\$2.53	\$2.69	\$2.53	\$2.53	\$2.53	\$2.48	\$2.48	\$2.69	\$2.55	\$2.55	\$2.57	
Average Case	2027-2028	Oct	\$2.57	\$2.57	\$3.34	\$2.62	\$3.34	\$2.62	\$2.62	\$2.62	\$2.57	\$2.57	\$3.34	\$2.83	\$2.83	\$2.77	
Average Case	2028-2029	Nov	\$2.85	\$2.85	\$2.97	\$2.91	\$2.97	\$2.91	\$2.91	\$2.91	\$2.85	\$2.85	\$2.97	\$2.89	\$2.89	\$2.92	
Average Case	2028-2029	Dec	\$2.95	\$2.90	\$2.97	\$2.99	\$3.00	\$2.99	\$2.99	\$2.99	\$2.95	\$2.90	\$2.97	\$2.94	\$2.94	\$3.00	
Average Case	2028-2029	Jan	\$3.02	\$3.02	\$3.02	\$3.08	\$3.10	\$3.08	\$3.08	\$3.08	\$3.02	\$3.02	\$3.02	\$3.02	\$3.02	\$3.08	
Average Case	2028-2029	Feb	\$2.88	\$2.88	\$2.97	\$2.93	\$2.97	\$2.93	\$2.93	\$2.93	\$2.88	\$2.88	\$2.97	\$2.91	\$2.91	\$2.94	
Average Case	2028-2029	Mar	\$2.73	\$2.73	\$3.01	\$2.78	\$3.01	\$2.78	\$2.78	\$2.78	\$2.73	\$2.73	\$3.01	\$2.82	\$2.82	\$2.83	
Average Case	2028-2029	Apr	\$2.52	\$2.52	\$3.11	\$2.57	\$3.11	\$3.11	\$3.11	\$3.11	\$2.52	\$2.52	\$3.11	\$2.72	\$2.72	\$3.00	
Average Case	2028-2029	May	\$2.58	\$2.58	\$2.84	\$2.63	\$2.84	\$2.63	\$2.63	\$2.63	\$2.58	\$2.58	\$2.84	\$2.67	\$2.67	\$2.67	
Average Case	2028-2029	Jun	\$2.57	\$2.57	\$2.84	\$2.63	\$2.84	\$2.63	\$2.63	\$2.63	\$2.57	\$2.57	\$2.84	\$2.66	\$2.66	\$2.67	
Average Case	2028-2029	Jul	\$2.56	\$2.56	\$2.84	\$2.61	\$2.84	\$2.61	\$2.61	\$2.61	\$2.56	\$2.56	\$2.84	\$2.65	\$2.65	\$2.65	
Average Case	2028-2029	Aug	\$2.56	\$2.56	\$2.84	\$2.61	\$2.84	\$2.61	\$2.61	\$2.61	\$2.56	\$2.56	\$2.84	\$2.65	\$2.65	\$2.65	
Average Case	2028-2029	Sep	\$2.61	\$2.61	\$2.84	\$2.66	\$2.84	\$2.66	\$2.66	\$2.66	\$2.61	\$2.61	\$2.84	\$2.69	\$2.69	\$2.70	
Average Case	2028-2029	Oct	\$2.66	\$2.66	\$3.44	\$2.71	\$3.44	\$2.71	\$2.71	\$2.71	\$2.66	\$2.66	\$3.44	\$2.92	\$2.92	\$2.86	
Average Case	2029-2030	Nov	\$2.96	\$2.96	\$3.07	\$3.02	\$3.07	\$3.02	\$3.02	\$3.02	\$2.96	\$2.96	\$3.07	\$3.00	\$3.00	\$3.03	
Average Case	2029-2030	Dec	\$3.09	\$3.09	\$3.09	\$3.16	\$3.16	\$3.16	\$3.16	\$3.16	\$3.09	\$3.09	\$3.09	\$3.09	\$3.09	\$3.16	
Average Case	2029-2030	Jan	\$3.12	\$3.12	\$3.12	\$3.18	\$3.21	\$3.18	\$3.18	\$3.18	\$3.12	\$3.12	\$3.12	\$3.12	\$3.12	\$3.19	
Average Case	2029-2030	Feb	\$3.00	\$3.00	\$3.07	\$3.06	\$3.07	\$3.06	\$3.06	\$3.06	\$3.00	\$3.00	\$3.07	\$3.03	\$3.03	\$3.06	
Average Case	2029-2030	Mar	\$2.87	\$2.87	\$3.12	\$2.93	\$3.12	\$2.93	\$2.93	\$2.93	\$2.87	\$2.87	\$3.12	\$2.95	\$2.95	\$2.96	
Average Case	2029-2030	Apr	\$2.63	\$2.63	\$3.25	\$2.69	\$3.25	\$2.69	\$3.25	\$3.25	\$2.63	\$2.63	\$3.25	\$2.84	\$2.84	\$3.14	
Average Case	2029-2030	May	\$2.67	\$2.67	\$2.92	\$2.72	\$2.92	\$2.72	\$2.72	\$2.72	\$2.67	\$2.67	\$2.92	\$2.75	\$2.75	\$2.76	
Average Case	2029-2030	Jun	\$2.64	\$2.64	\$2.92	\$2.69	\$2.92	\$2.69	\$2.69	\$2.69	\$2.64	\$2.64	\$2.92	\$2.73	\$2.73	\$2.74	
Average Case	2029-2030	Jul	\$2.59	\$2.59	\$2.92	\$2.64	\$2.92	\$2.64	\$2.64	\$2.64	\$2.59	\$2.59	\$2.92	\$2.70	\$2.70	\$2.69	
Average Case	2029-2030	Aug	\$2.61	\$2.61	\$2.92	\$2.66	\$2.92	\$2.66	\$2.66	\$2.66	\$2.61	\$2.61	\$2.92	\$2.72	\$2.72	\$2.72	
Average Case	2029-2030	Sep	\$2.67	\$2.67	\$2.92	\$2.72	\$2.92	\$2.72	\$2.72	\$2.72	\$2.67	\$2.67	\$2.92	\$2.75	\$2.75	\$2.76	
Average Case	2029-2030	Oct	\$2.80	\$2.80	\$3.41	\$2.86	\$3.41	\$2.86	\$2.86	\$2.86	\$2.80	\$2.80	\$3.41	\$3.00	\$3.00	\$2.97	
Average Case	2030-2031	Nov	\$3.11	\$3.10	\$3.20	\$3.16	\$3.20	\$3.16	\$3.16	\$3.16	\$3.11	\$3.10	\$3.20	\$3.14	\$3.14	\$3.17	
Average Case	2030-2031	Dec	\$3.25	\$3.25	\$3.25	\$3.32	\$3.32	\$3.32	\$3.32	\$3.32	\$3.25	\$3.25	\$3.25	\$3.25	\$3.25	\$3.32	
Average Case	2030-2031	Jan	\$3.26	\$3.26	\$3.26	\$3.32	\$3.32	\$3.32	\$3.32	\$3.32	\$3.26	\$3.26	\$3.26	\$3.26	\$3.26	\$3.32	
Average Case	2030-2031	Feb	\$3.16	\$3.16	\$3.20	\$3.22	\$3.22	\$3.22	\$3.22	\$3.22	\$3.16	\$3.16	\$3.20	\$3.17	\$3.17	\$3.22	
Average Case	2030-2031	Mar	\$2.99	\$2.99	\$3.24	\$3.05	\$3.24	\$3.05	\$3.05	\$3.05	\$2.99	\$2.99	\$3.24	\$3.07	\$3.07	\$3.09	
Average Case	2030-2031	Apr	\$2.78	\$2.78	\$3.43	\$2.83	\$3.43	\$2.83	\$3.43	\$3.43	\$2.78	\$2.78	\$3.43	\$3.00	\$3.00	\$3.31	
Average Case	2030-2031	May	\$2.80	\$2.80	\$3.10	\$2.85	\$3.10	\$2.85	\$2.85	\$2.85	\$2.80	\$2.80	\$3.10	\$2.90	\$2.90	\$2.90	
Average Case	2030-2031	Jun	\$2.77	\$2.77	\$3.10	\$2.82	\$3.10	\$2.82	\$2.82	\$2.82	\$2.77	\$2.77	\$3.10	\$2.88	\$2.88	\$2.88	
Average Case	2030-2031	Jul	\$2.73	\$2.73	\$3.10	\$2.78	\$3.10	\$2.78	\$2.78	\$2.78	\$2.73	\$2.73	\$3.10	\$2.85	\$2.85	\$2.84	
Average Case	2030-2031	Aug	\$2.72	\$2.72	\$3.10	\$2.78	\$3.10	\$2.78	\$2.78	\$2.78	\$2.72	\$2.72	\$3.10	\$2.85	\$2.85	\$2.84	
Average Case	2030-2031	Sep	\$2.83	\$2.83	\$3.10	\$2.88	\$3.10	\$2.88	\$2.88	\$2.88	\$2.83	\$2.83	\$3.10	\$2.92	\$2.92	\$2.92	
Average Case	2030-2031	Oct	\$2.88	\$2.88	\$3.51	\$2.94	\$3.51	\$2.94	\$2.94	\$2.94	\$2.88	\$2.88	\$3.51	\$3.09	\$3.09	\$3.05	
Average Case	2031-2032	Nov	\$3.24	\$3.23	\$3.30	\$3.29	\$3.30	\$3.29	\$3.29	\$3.29	\$3.24	\$3.23	\$3.30	\$3.25	\$3.25	\$3.29	
Average Case	2031-2032	Dec	\$3.33	\$3.33	\$3.33	\$3.41	\$3.41	\$3.41	\$3.41	\$3.41	\$3.33	\$3.33	\$3.33	\$3.33	\$3.33	\$3.41	
Average Case	2031-2032	Jan	\$3.35	\$3.35	\$3.35	\$3.42	\$3.42	\$3.42	\$3.42	\$3.42	\$3.35	\$3.35	\$3.35	\$3.35	\$3.35	\$3.42	
Average Case	2031-2032	Feb	\$3.23	\$3.22	\$3.30	\$3.28	\$3.30	\$3.28	\$3.28	\$3.28	\$3.23	\$3.22	\$3.30	\$3.25	\$3.25	\$3.29	
Average Case	2031-2032	Mar	\$3.06	\$3.06	\$3.35	\$3.12	\$3.35	\$3.12	\$3.12	\$3.12	\$3.06	\$3.06	\$3.35	\$3.16	\$3.16	\$3.17	
Average Case	2031-2032	Apr	\$2.89	\$2.89	\$3.56	\$2.95	\$3.56	\$2.95	\$2.95	\$2.95	\$2.89	\$2.89	\$3.56	\$3.12	\$3.12	\$3.44	
Average Case	2031-2032	May	\$2.87	\$2.87	\$3.14	\$2.93	\$3.14	\$2.93	\$2.93	\$2.93	\$2.87	\$2.87	\$3.14	\$2.96	\$2.96	\$2.97	
Average Case	2031-2032	Jun	\$2.83	\$2.83	\$3.15	\$2.89	\$3.14	\$2.89	\$2.89	\$2.89	\$2.83	\$2.83	\$3.15	\$2.93	\$2.93	\$2.94	
Average Case	2031-2032	Jul	\$2.65	\$2.65	\$3.15	\$2.70	\$3.15	\$2.70	\$2.70	\$2.70	\$2.65	\$2.65	\$3.15	\$2.81	\$2.81	\$2.79	
Average Case	2031-2032	Aug	\$2.68	\$2.68	\$3.15	\$2.73	\$3.15	\$2.73	\$2.73	\$2.73	\$2.68	\$2.68	\$3.15	\$2.83	\$2.83	\$2.81	
Average Case	2031-2032	Sep	\$2.87	\$2.87	\$3.15	\$2.93	\$3.15	\$2.93	\$2.93	\$2.93	\$2.87	\$2.87	\$3.15	\$2.96	\$2.96	\$2.97	
Average Case	2031-2032	Oct	\$2.99	\$2.99	\$3.63	\$3.05	\$3.63	\$3.05	\$3.05	\$3.05	\$2.99	\$2.99	\$3.63	\$3.21	\$3.21	\$3.17	
Average Case	2032-2033	Nov	\$3.40	\$3.38	\$3.51	\$3.45	\$3.51	\$3.45	\$3.45	\$3.45	\$3.40	\$3.38	\$3.51	\$3.43	\$3.43	\$3.46	
Average Case	2032-2033	Dec	\$3.51	\$3.49	\$3.51	\$3.61	\$3.61	\$3.61	\$3.61	\$3.61	\$3.51	\$3.49	\$3.51	\$3.51	\$3.51	\$3.61	
Average Case	2032-2033	Jan	\$3.57	\$3.57	\$3.57	\$3.64	\$3.67	\$3.64	\$3.64	\$3.64	\$3.57	\$3.57	\$3.57	\$3.57	\$3.57	\$3.64	
Average Case	2032-2033	Feb	\$3.51	\$3.51	\$3.51	\$3.57	\$3.57	\$3.57	\$3.57	\$3.57	\$3.51	\$3.51	\$3.51	\$3.51	\$3.51	\$3.57	
Average Case	2032-2033	Mar	\$3.35	\$3.35	\$3.54	\$3.42	\$3.54	\$3.42	\$3.42	\$3.42	\$3.35	\$3.35	\$3.54	\$3.42	\$3.42	\$3.44	
Average Case	2032-2033	Apr	\$3.16	\$3.16	\$3.81	\$3.22	\$3.81	\$3.21	\$3.21	\$3.21	\$3.16	\$3.16	\$3.81	\$3.38	\$3.38	\$3.69	
Average Case	2032-2033	May	\$3.14	\$3.14	\$3.44	\$3.21	\$3.44	\$3.21	\$3.21	\$3.21	\$3.14	\$3.14	\$3.44	\$3.24	\$3.24	\$3.25	
Average Case	2032-2033	Jun	\$3.15	\$3.15	\$3.45	\$3.21	\$3.45	\$3.21	\$3.21	\$3.21	\$3.15	\$3.15	\$3.45	\$3.25	\$3.25	\$3.26	
Average Case	2032-2033	Jul	\$3.02	\$3.02	\$3.45	\$3.08	\$3.45	\$3.08	\$3.08	\$3.08	\$3.02	\$3.02	\$3.45	\$3.16	\$3.16	\$3.15	
Average Case	2032-2033	Aug	\$3.04	\$3.04	\$3.45	\$3.10	\$3.45	\$3.10	\$3.10	\$3.10	\$3.04	\$3.04	\$3.45	\$3.18	\$3.18	\$3.17	
Average Case	2032-2033	Sep	\$3.17	\$3.17	\$3.45	\$3.23	\$3.45	\$3.23	\$3.23	\$3.23	\$3.17	\$3.17	\$3.45	\$3.26	\$3.26	\$3.28	
Average Case	2032-2033	Oct	\$3.26	\$3.26	\$3.88	\$3.32	\$3.88	\$3.32	\$3.32	\$3.32	\$3.26	\$3.26	\$3.88	\$3.47	\$3.47	\$3.43	
Average Case	2033-2034	Nov	\$3.68	\$3.67	\$3.72	\$3.74	\$3.74	\$3.74	\$3.74	\$3.74	\$3.68	\$3.67	\$3.72	\$3.69	\$3.69	\$3.74	
Average Case	2033-2034	Dec	\$3.74	\$3.73	\$3.74	\$3.84	\$3.84	\$3.84	\$3.84	\$3.84	\$3.74	\$3.73	\$3.74	\$3.73	\$3.73	\$3.84	
Average Case	2033-2034	Jan	\$3.78	\$3.78	\$3.78	\$3.86	\$3.89	\$3.86	\$3.86	\$3.86	\$3.78	\$3.78	\$3.78	\$3.78	\$3.78	\$3.86	
Average Case	2033-2034	Feb	\$3.69	\$3.67	\$3.73	\$3.74	\$3.74	\$3.74	\$3.74	\$3.74	\$3.69	\$3.67	\$3.73	\$3.70	\$3.70	\$3.74	
Average Case	2033-2034	Mar	\$3.52	\$3.52	\$3.76	\$3.59	\$3.76	\$3.59	\$3.59	\$3.59	\$3.52	\$3.52	\$3.76	\$3.60	\$3.60	\$3.62	
Average Case	2033-2034	Apr	\$3.31	\$3.31	\$3.96	\$3.38	\$3.9										

Monthly Avoided Costs ¹																	
Nominal \$																	
Scenario	Gas Year	Month	ID Both	ID GTN	ID NWP	Klamath Falls	La Grande	Medford	GTN	Medford NWP	Roseburg	WA Both	WA GTN	WA NWP	Idaho	Washington	Oregon
Average Case	2035-2036	Jan	\$4.12	\$4.12	\$4.12	\$4.20	\$4.23	\$4.20	\$4.20	\$4.20	\$4.20	\$4.12	\$4.12	\$4.12	\$4.12	\$4.12	\$4.21
Average Case	2035-2036	Feb	\$4.06	\$4.05	\$4.06	\$4.13	\$4.13	\$4.13	\$4.13	\$4.13	\$4.13	\$4.06	\$4.05	\$4.06	\$4.05	\$4.05	\$4.13
Average Case	2035-2036	Mar	\$3.86	\$3.86	\$4.13	\$3.93	\$4.13	\$3.93	\$3.93	\$3.93	\$3.86	\$3.86	\$4.13	\$3.95	\$3.95	\$3.97	\$3.97
Average Case	2035-2036	Apr	\$3.62	\$3.62	\$4.16	\$3.69	\$4.16	\$4.16	\$4.16	\$4.16	\$3.62	\$3.62	\$4.16	\$3.80	\$3.80	\$4.06	\$4.06
Average Case	2035-2036	May	\$3.62	\$3.62	\$3.85	\$3.69	\$3.85	\$3.69	\$3.69	\$3.69	\$3.62	\$3.62	\$3.85	\$3.69	\$3.69	\$3.72	\$3.72
Average Case	2035-2036	Jun	\$3.60	\$3.60	\$3.85	\$3.67	\$3.85	\$3.67	\$3.67	\$3.67	\$3.60	\$3.60	\$3.85	\$3.68	\$3.68	\$3.70	\$3.70
Average Case	2035-2036	Jul	\$3.39	\$3.39	\$3.85	\$3.45	\$3.85	\$3.45	\$3.45	\$3.45	\$3.39	\$3.39	\$3.85	\$3.54	\$3.54	\$3.53	\$3.53
Average Case	2035-2036	Aug	\$3.42	\$3.42	\$3.85	\$3.48	\$3.85	\$3.48	\$3.48	\$3.48	\$3.42	\$3.42	\$3.85	\$3.56	\$3.56	\$3.56	\$3.56
Average Case	2035-2036	Sep	\$3.57	\$3.57	\$3.85	\$3.64	\$3.85	\$3.64	\$3.64	\$3.64	\$3.57	\$3.57	\$3.85	\$3.66	\$3.66	\$3.68	\$3.68
Average Case	2035-2036	Oct	\$3.73	\$3.73	\$4.29	\$3.80	\$4.29	\$4.29	\$4.29	\$4.29	\$3.73	\$3.73	\$4.29	\$3.91	\$3.91	\$4.19	\$4.19
Average Case	2036-2037	Nov	\$4.15	\$4.14	\$4.26	\$4.22	\$4.26	\$4.22	\$4.22	\$4.22	\$4.15	\$4.14	\$4.26	\$4.19	\$4.19	\$4.23	\$4.23
Average Case	2036-2037	Dec	\$4.28	\$4.27	\$4.28	\$4.39	\$4.39	\$4.39	\$4.39	\$4.39	\$4.28	\$4.27	\$4.28	\$4.28	\$4.28	\$4.28	\$4.39
Average Case	2036-2037	Jan	\$4.32	\$4.32	\$4.32	\$4.41	\$4.44	\$4.41	\$4.41	\$4.41	\$4.32	\$4.32	\$4.32	\$4.32	\$4.32	\$4.32	\$4.41
Average Case	2036-2037	Feb	\$4.21	\$4.11	\$4.26	\$4.18	\$4.26	\$4.18	\$4.18	\$4.18	\$4.21	\$4.11	\$4.26	\$4.19	\$4.19	\$4.20	\$4.20
Average Case	2036-2037	Mar	\$3.93	\$3.93	\$4.32	\$4.01	\$4.32	\$4.01	\$4.01	\$4.01	\$3.93	\$3.93	\$4.32	\$4.06	\$4.06	\$4.07	\$4.07
Average Case	2036-2037	Apr	\$3.66	\$3.66	\$4.22	\$3.73	\$4.22	\$4.22	\$4.22	\$4.22	\$3.66	\$3.66	\$4.22	\$3.85	\$3.85	\$4.12	\$4.12
Average Case	2036-2037	May	\$3.80	\$3.80	\$4.09	\$3.87	\$4.09	\$3.87	\$3.87	\$3.87	\$3.80	\$3.80	\$4.09	\$3.89	\$3.89	\$3.91	\$3.91
Average Case	2036-2037	Jun	\$3.77	\$3.77	\$4.09	\$3.85	\$4.09	\$3.85	\$3.85	\$3.85	\$3.77	\$3.77	\$4.09	\$3.88	\$3.88	\$3.89	\$3.89
Average Case	2036-2037	Jul	\$3.65	\$3.65	\$4.09	\$3.72	\$4.09	\$3.72	\$3.72	\$3.72	\$3.65	\$3.65	\$4.09	\$3.79	\$3.79	\$3.79	\$3.79
Average Case	2036-2037	Aug	\$3.74	\$3.74	\$4.09	\$3.81	\$4.09	\$3.81	\$3.81	\$3.81	\$3.74	\$3.74	\$4.09	\$3.86	\$3.86	\$3.87	\$3.87
Average Case	2036-2037	Sep	\$3.84	\$3.84	\$4.09	\$3.91	\$4.09	\$3.91	\$3.91	\$3.91	\$3.84	\$3.84	\$4.09	\$3.92	\$3.92	\$3.95	\$3.95
Average Case	2036-2037	Oct	\$3.97	\$3.97	\$4.53	\$4.05	\$4.53	\$4.53	\$4.53	\$4.53	\$3.97	\$3.97	\$4.53	\$4.16	\$4.16	\$4.43	\$4.43
Average Case	2037-2038	Nov	\$4.46	\$4.44	\$4.56	\$4.52	\$4.56	\$4.52	\$4.52	\$4.52	\$4.46	\$4.44	\$4.56	\$4.49	\$4.49	\$4.53	\$4.53
Average Case	2037-2038	Dec	\$4.62	\$4.61	\$4.62	\$4.71	\$4.71	\$4.71	\$4.71	\$4.71	\$4.62	\$4.61	\$4.62	\$4.61	\$4.61	\$4.71	\$4.71
Average Case	2037-2038	Jan	\$4.63	\$4.63	\$4.63	\$4.72	\$4.86	\$4.72	\$4.72	\$4.72	\$4.63	\$4.63	\$4.63	\$4.63	\$4.63	\$4.75	\$4.75
Average Case	2037-2038	Feb	\$4.49	\$4.34	\$4.56	\$4.42	\$4.56	\$4.42	\$4.42	\$4.42	\$4.49	\$4.34	\$4.56	\$4.47	\$4.47	\$4.45	\$4.45
Average Case	2037-2038	Mar	\$4.08	\$4.08	\$4.68	\$4.16	\$4.68	\$4.16	\$4.16	\$4.16	\$4.08	\$4.08	\$4.68	\$4.28	\$4.28	\$4.26	\$4.26
Average Case	2037-2038	Apr	\$3.87	\$3.87	\$4.40	\$3.95	\$4.40	\$4.40	\$4.40	\$4.40	\$3.87	\$3.87	\$4.40	\$4.05	\$4.05	\$4.31	\$4.31
Average Case	2037-2038	May	\$3.91	\$3.91	\$4.13	\$3.98	\$4.13	\$3.98	\$3.98	\$3.98	\$3.91	\$3.91	\$4.13	\$3.98	\$3.98	\$4.01	\$4.01
Average Case	2037-2038	Jun	\$3.91	\$3.91	\$4.13	\$3.99	\$4.13	\$3.99	\$3.99	\$3.99	\$3.91	\$3.91	\$4.13	\$3.98	\$3.98	\$4.01	\$4.01
Average Case	2037-2038	Jul	\$3.74	\$3.74	\$4.13	\$3.82	\$4.13	\$3.82	\$3.82	\$3.82	\$3.74	\$3.74	\$4.13	\$3.87	\$3.87	\$3.88	\$3.88
Average Case	2037-2038	Aug	\$3.77	\$3.77	\$4.13	\$3.84	\$4.13	\$3.84	\$3.84	\$3.84	\$3.77	\$3.77	\$4.13	\$3.89	\$3.89	\$3.90	\$3.90
Average Case	2037-2038	Sep	\$3.87	\$3.87	\$4.13	\$3.95	\$4.13	\$3.95	\$3.95	\$3.95	\$3.87	\$3.87	\$4.13	\$3.96	\$3.96	\$3.98	\$3.98
Average Case	2037-2038	Oct	\$4.00	\$4.00	\$4.54	\$4.08	\$4.54	\$4.54	\$4.54	\$4.54	\$4.00	\$4.00	\$4.54	\$4.18	\$4.18	\$4.45	\$4.45
Average Case	2038-2039	Nov	\$4.50	\$4.46	\$4.66	\$4.54	\$4.66	\$4.54	\$4.54	\$4.54	\$4.50	\$4.46	\$4.66	\$4.54	\$4.54	\$4.56	\$4.56
Average Case	2038-2039	Dec	\$4.70	\$4.67	\$4.70	\$4.81	\$4.84	\$4.81	\$4.81	\$4.81	\$4.70	\$4.67	\$4.70	\$4.69	\$4.69	\$4.82	\$4.82
Average Case	2038-2039	Jan	\$4.73	\$4.73	\$4.73	\$4.82	\$4.97	\$4.82	\$4.82	\$4.82	\$4.73	\$4.73	\$4.73	\$4.73	\$4.73	\$4.85	\$4.85
Average Case	2038-2039	Feb	\$4.61	\$4.51	\$4.66	\$4.60	\$4.66	\$4.60	\$4.60	\$4.60	\$4.61	\$4.51	\$4.66	\$4.59	\$4.59	\$4.61	\$4.61
Average Case	2038-2039	Mar	\$4.37	\$4.37	\$4.74	\$4.45	\$4.74	\$4.45	\$4.45	\$4.45	\$4.37	\$4.37	\$4.74	\$4.49	\$4.49	\$4.51	\$4.51
Average Case	2038-2039	Apr	\$4.13	\$4.13	\$4.65	\$4.20	\$4.65	\$4.65	\$4.65	\$4.65	\$4.13	\$4.13	\$4.65	\$4.30	\$4.30	\$4.56	\$4.56
Average Case	2038-2039	May	\$4.16	\$4.16	\$4.39	\$4.24	\$4.39	\$4.24	\$4.24	\$4.24	\$4.16	\$4.16	\$4.39	\$4.23	\$4.23	\$4.27	\$4.27
Average Case	2038-2039	Jun	\$4.07	\$4.07	\$4.39	\$4.15	\$4.39	\$4.15	\$4.15	\$4.15	\$4.07	\$4.07	\$4.39	\$4.18	\$4.18	\$4.20	\$4.20
Average Case	2038-2039	Jul	\$3.94	\$3.94	\$4.39	\$4.01	\$4.39	\$4.01	\$4.01	\$4.01	\$3.94	\$3.94	\$4.39	\$4.09	\$4.09	\$4.09	\$4.09
Average Case	2038-2039	Aug	\$3.94	\$3.94	\$4.39	\$4.02	\$4.39	\$4.02	\$4.02	\$4.02	\$3.94	\$3.94	\$4.39	\$4.09	\$4.09	\$4.09	\$4.09
Average Case	2038-2039	Sep	\$4.13	\$4.13	\$4.39	\$4.20	\$4.39	\$4.20	\$4.20	\$4.20	\$4.13	\$4.13	\$4.39	\$4.21	\$4.21	\$4.24	\$4.24
Average Case	2038-2039	Oct	\$4.24	\$4.24	\$4.78	\$4.32	\$4.78	\$4.78	\$4.78	\$4.78	\$4.24	\$4.24	\$4.78	\$4.42	\$4.42	\$4.69	\$4.69
Average Case	2039-2040	Nov	\$4.77	\$4.74	\$4.84	\$4.83	\$4.84	\$4.83	\$4.83	\$4.83	\$4.77	\$4.74	\$4.84	\$4.78	\$4.78	\$4.83	\$4.83
Average Case	2039-2040	Dec	\$4.90	\$4.89	\$4.90	\$5.00	\$5.04	\$5.00	\$5.00	\$5.00	\$4.90	\$4.89	\$4.90	\$4.90	\$4.90	\$5.01	\$5.01
Average Case	2039-2040	Jan	\$4.91	\$4.91	\$4.91	\$5.01	\$5.16	\$5.01	\$5.01	\$5.01	\$4.91	\$4.91	\$4.91	\$4.91	\$4.91	\$5.04	\$5.04
Average Case	2039-2040	Feb	\$4.82	\$4.68	\$4.84	\$4.77	\$4.84	\$4.77	\$4.77	\$4.77	\$4.82	\$4.68	\$4.84	\$4.78	\$4.78	\$4.79	\$4.79
Average Case	2039-2040	Mar	\$4.51	\$4.51	\$4.93	\$4.59	\$4.93	\$4.59	\$4.59	\$4.59	\$4.51	\$4.51	\$4.93	\$4.65	\$4.65	\$4.66	\$4.66
Average Case	2039-2040	Apr	\$4.28	\$4.28	\$4.82	\$4.36	\$4.82	\$4.82	\$4.82	\$4.82	\$4.28	\$4.28	\$4.82	\$4.46	\$4.46	\$4.73	\$4.73
Average Case	2039-2040	May	\$4.31	\$4.31	\$4.55	\$4.40	\$4.55	\$4.40	\$4.40	\$4.40	\$4.31	\$4.31	\$4.55	\$4.39	\$4.39	\$4.43	\$4.43
Average Case	2039-2040	Jun	\$4.29	\$4.29	\$4.55	\$4.37	\$4.55	\$4.37	\$4.37	\$4.37	\$4.29	\$4.29	\$4.55	\$4.38	\$4.38	\$4.41	\$4.41
Average Case	2039-2040	Jul	\$4.17	\$4.17	\$4.55	\$4.25	\$4.55	\$4.25	\$4.25	\$4.25	\$4.17	\$4.17	\$4.55	\$4.30	\$4.30	\$4.31	\$4.31
Average Case	2039-2040	Aug	\$4.21	\$4.21	\$4.55	\$4.29	\$4.55	\$4.29	\$4.29	\$4.29	\$4.21	\$4.21	\$4.55	\$4.32	\$4.32	\$4.34	\$4.34
Average Case	2039-2040	Sep	\$4.34	\$4.34	\$4.55	\$4.43	\$4.55	\$4.43	\$4.43	\$4.43	\$4.34	\$4.34	\$4.55	\$4.41	\$4.41	\$4.45	\$4.45
Average Case	2039-2040	Oct	\$4.46	\$4.46	\$4.99	\$4.54	\$4.99	\$4.99	\$4.99	\$4.99	\$4.46	\$4.46	\$4.99	\$4.63	\$4.63	\$4.90	\$4.90

¹Avoided costs are before Environmental Externalities adder

APPENDIX 6.4: CARBON REDUCTION MONTHLY DETAIL

Monthly Avoided Costs ¹																
Nominal \$																
Scenario	Gas Year	Month	ID Both	ID GTN	ID NWP	Klamath Falls	La Grande	Medford GTN	Medford NWP	Roseburg	WA Both	WA GTN	WA NWP	Idaho	Washington	Oregon
Carbon Reduction	2019-2020	Nov	\$2.00	\$2.18	\$2.00	\$2.22	\$2.22	\$2.22	\$2.22	\$2.22	\$2.00	\$2.18	\$2.00	\$2.06	\$2.06	\$2.22
Carbon Reduction	2019-2020	Dec	\$1.99	\$1.87	\$1.99	\$2.17	\$2.25	\$2.17	\$2.17	\$2.17	\$1.99	\$1.87	\$1.99	\$1.95	\$1.95	\$2.19
Carbon Reduction	2019-2020	Jan	\$2.00	\$1.80	\$2.00	\$1.84	\$2.02	\$1.84	\$1.84	\$1.84	\$2.00	\$1.80	\$2.00	\$1.93	\$1.93	\$1.88
Carbon Reduction	2019-2020	Feb	\$1.95	\$1.43	\$1.97	\$1.90	\$1.97	\$1.90	\$1.90	\$1.90	\$1.95	\$1.43	\$1.97	\$1.79	\$1.79	\$1.60
Carbon Reduction	2019-2020	Mar	\$1.25	\$1.25	\$1.38	\$1.28	\$1.38	\$1.28	\$1.28	\$1.28	\$1.25	\$1.25	\$1.38	\$1.30	\$1.30	\$1.30
Carbon Reduction	2019-2020	Apr	\$1.03	\$1.03	\$1.15	\$1.05	\$1.14	\$1.15	\$1.15	\$1.15	\$1.03	\$1.03	\$1.15	\$1.07	\$1.07	\$1.13
Carbon Reduction	2019-2020	May	\$1.05	\$1.14	\$1.05	\$1.07	\$1.05	\$1.05	\$1.05	\$1.05	\$1.05	\$1.14	\$1.05	\$1.08	\$1.08	\$1.06
Carbon Reduction	2019-2020	Jun	\$0.90	\$0.90	\$1.06	\$0.86	\$0.90	\$0.86	\$0.86	\$0.86	\$0.90	\$0.90	\$1.06	\$0.95	\$0.95	\$0.87
Carbon Reduction	2019-2020	Jul	\$0.86	\$0.86	\$1.06	\$0.80	\$0.90	\$0.80	\$0.80	\$0.80	\$0.86	\$0.86	\$1.06	\$0.93	\$0.93	\$0.82
Carbon Reduction	2019-2020	Aug	\$1.10	\$1.10	\$1.11	\$1.13	\$1.11	\$1.11	\$1.11	\$1.11	\$1.10	\$1.10	\$1.11	\$1.11	\$1.11	\$1.12
Carbon Reduction	2019-2020	Sep	\$0.99	\$0.99	\$1.06	\$1.01	\$1.06	\$1.01	\$1.01	\$1.01	\$0.99	\$0.99	\$1.06	\$1.01	\$1.01	\$1.02
Carbon Reduction	2019-2020	Oct	\$1.02	\$1.02	\$1.31	\$1.04	\$1.31	\$1.04	\$1.04	\$1.04	\$1.02	\$1.02	\$1.31	\$1.12	\$1.12	\$1.10
Carbon Reduction	2020-2021	Nov	\$1.81	\$1.81	\$1.82	\$1.74	\$1.82	\$1.74	\$1.74	\$1.74	\$1.81	\$1.81	\$1.82	\$1.81	\$1.81	\$1.75
Carbon Reduction	2020-2021	Dec	\$2.01	\$2.36	\$2.01	\$2.41	\$2.41	\$2.41	\$2.41	\$2.41	\$2.01	\$2.36	\$2.01	\$2.13	\$2.13	\$2.41
Carbon Reduction	2020-2021	Jan	\$1.93	\$1.80	\$1.93	\$1.83	\$1.93	\$1.83	\$1.83	\$1.83	\$1.93	\$1.80	\$1.93	\$1.88	\$1.88	\$1.85
Carbon Reduction	2020-2021	Feb	\$2.02	\$1.69	\$2.02	\$1.75	\$2.02	\$1.75	\$1.75	\$1.75	\$2.02	\$1.69	\$2.02	\$1.91	\$1.91	\$1.81
Carbon Reduction	2020-2021	Mar	\$1.38	\$1.38	\$1.67	\$1.41	\$1.67	\$1.41	\$1.41	\$1.41	\$1.38	\$1.38	\$1.67	\$1.48	\$1.48	\$1.46
Carbon Reduction	2020-2021	Apr	\$0.91	\$0.91	\$1.27	\$0.93	\$1.27	\$1.25	\$1.25	\$1.25	\$0.91	\$0.91	\$1.27	\$1.03	\$1.03	\$1.19
Carbon Reduction	2020-2021	May	\$0.81	\$0.81	\$1.28	\$0.83	\$1.24	\$0.83	\$0.83	\$0.83	\$0.81	\$0.81	\$1.28	\$0.96	\$0.96	\$0.91
Carbon Reduction	2020-2021	Jun	\$0.85	\$0.85	\$1.28	\$0.87	\$1.22	\$0.87	\$0.87	\$0.87	\$0.85	\$0.85	\$1.28	\$0.99	\$0.99	\$0.94
Carbon Reduction	2020-2021	Jul	\$0.96	\$0.96	\$1.28	\$0.99	\$1.28	\$0.99	\$0.99	\$0.99	\$0.96	\$0.96	\$1.28	\$1.07	\$1.07	\$1.05
Carbon Reduction	2020-2021	Aug	\$0.96	\$0.96	\$1.28	\$0.98	\$1.28	\$0.98	\$0.98	\$0.98	\$0.96	\$0.96	\$1.28	\$1.06	\$1.06	\$1.04
Carbon Reduction	2020-2021	Sep	\$0.81	\$0.81	\$1.28	\$0.83	\$1.28	\$0.83	\$0.83	\$0.83	\$0.81	\$0.81	\$1.28	\$0.96	\$0.96	\$0.92
Carbon Reduction	2020-2021	Oct	\$0.83	\$0.83	\$1.44	\$0.85	\$1.44	\$0.85	\$0.85	\$0.85	\$0.83	\$0.83	\$1.44	\$1.03	\$1.03	\$0.97
Carbon Reduction	2021-2022	Nov	\$1.17	\$1.17	\$1.45	\$1.19	\$1.45	\$1.19	\$1.19	\$1.19	\$1.17	\$1.17	\$1.45	\$1.26	\$1.26	\$1.25
Carbon Reduction	2021-2022	Dec	\$1.44	\$1.40	\$1.46	\$1.50	\$1.53	\$1.50	\$1.50	\$1.50	\$1.44	\$1.40	\$1.46	\$1.43	\$1.43	\$1.51
Carbon Reduction	2021-2022	Jan	\$1.48	\$1.48	\$1.48	\$1.51	\$1.53	\$1.51	\$1.51	\$1.51	\$1.48	\$1.48	\$1.48	\$1.48	\$1.48	\$1.52
Carbon Reduction	2021-2022	Feb	\$1.39	\$1.34	\$1.49	\$1.42	\$1.49	\$1.42	\$1.42	\$1.42	\$1.39	\$1.34	\$1.49	\$1.41	\$1.41	\$1.43
Carbon Reduction	2021-2022	Mar	\$1.06	\$1.06	\$1.43	\$1.09	\$1.43	\$1.09	\$1.09	\$1.09	\$1.06	\$1.06	\$1.43	\$1.19	\$1.19	\$1.16
Carbon Reduction	2021-2022	Apr	\$0.52	\$0.52	\$1.10	\$0.54	\$1.10	\$1.04	\$1.04	\$1.04	\$0.52	\$0.52	\$1.10	\$0.72	\$0.72	\$0.95
Carbon Reduction	2021-2022	May	\$0.50	\$0.50	\$1.10	\$0.51	\$1.10	\$0.51	\$0.51	\$0.51	\$0.50	\$0.50	\$1.10	\$0.70	\$0.70	\$0.63
Carbon Reduction	2021-2022	Jun	\$0.60	\$0.60	\$1.10	\$0.62	\$1.10	\$0.62	\$0.62	\$0.62	\$0.60	\$0.60	\$1.10	\$0.77	\$0.77	\$0.71
Carbon Reduction	2021-2022	Jul	\$0.74	\$0.74	\$1.10	\$0.76	\$1.10	\$0.76	\$0.76	\$0.76	\$0.74	\$0.74	\$1.10	\$0.86	\$0.86	\$0.83
Carbon Reduction	2021-2022	Aug	\$0.68	\$0.68	\$1.11	\$0.70	\$1.11	\$0.70	\$0.70	\$0.70	\$0.68	\$0.68	\$1.11	\$0.82	\$0.82	\$0.78
Carbon Reduction	2021-2022	Sep	\$0.51	\$0.51	\$1.11	\$0.52	\$1.11	\$0.52	\$0.52	\$0.52	\$0.51	\$0.51	\$1.11	\$0.71	\$0.71	\$0.64
Carbon Reduction	2021-2022	Oct	\$0.50	\$0.50	\$1.11	\$0.52	\$1.11	\$0.52	\$0.52	\$0.52	\$0.50	\$0.50	\$1.11	\$0.70	\$0.70	\$0.63
Carbon Reduction	2022-2023	Nov	\$0.77	\$0.77	\$1.25	\$0.79	\$1.25	\$0.79	\$0.79	\$0.79	\$0.77	\$0.77	\$1.25	\$0.93	\$0.93	\$0.88
Carbon Reduction	2022-2023	Dec	\$1.24	\$1.21	\$1.25	\$1.31	\$1.33	\$1.31	\$1.31	\$1.31	\$1.24	\$1.21	\$1.25	\$1.23	\$1.23	\$1.32
Carbon Reduction	2022-2023	Jan	\$1.27	\$1.27	\$1.27	\$1.30	\$1.32	\$1.30	\$1.30	\$1.30	\$1.27	\$1.27	\$1.27	\$1.27	\$1.27	\$1.31
Carbon Reduction	2022-2023	Feb	\$1.13	\$1.07	\$1.28	\$1.14	\$1.29	\$1.14	\$1.14	\$1.14	\$1.13	\$1.07	\$1.28	\$1.16	\$1.16	\$1.17
Carbon Reduction	2022-2023	Mar	\$0.84	\$0.84	\$1.20	\$0.86	\$1.20	\$0.86	\$0.86	\$0.86	\$0.84	\$0.84	\$1.20	\$0.96	\$0.96	\$0.93
Carbon Reduction	2022-2023	Apr	\$0.42	\$0.42	\$1.02	\$0.43	\$1.02	\$0.97	\$0.97	\$0.97	\$0.42	\$0.42	\$1.02	\$0.62	\$0.62	\$0.87
Carbon Reduction	2022-2023	May	\$0.40	\$0.40	\$1.02	\$0.41	\$0.99	\$0.41	\$0.41	\$0.41	\$0.40	\$0.40	\$1.02	\$0.61	\$0.61	\$0.53
Carbon Reduction	2022-2023	Jun	\$0.56	\$0.56	\$1.02	\$0.58	\$1.02	\$0.58	\$0.58	\$0.58	\$0.56	\$0.56	\$1.02	\$0.72	\$0.72	\$0.67
Carbon Reduction	2022-2023	Jul	\$0.60	\$0.60	\$1.02	\$0.62	\$1.02	\$0.62	\$0.62	\$0.62	\$0.60	\$0.60	\$1.02	\$0.74	\$0.74	\$0.70
Carbon Reduction	2022-2023	Aug	\$0.60	\$0.60	\$1.02	\$0.62	\$1.02	\$0.62	\$0.62	\$0.62	\$0.60	\$0.60	\$1.02	\$0.74	\$0.74	\$0.70
Carbon Reduction	2022-2023	Sep	\$0.33	\$0.33	\$1.02	\$0.34	\$1.02	\$0.34	\$0.34	\$0.34	\$0.33	\$0.33	\$1.02	\$0.56	\$0.56	\$0.48
Carbon Reduction	2022-2023	Oct	\$0.41	\$0.41	\$1.06	\$0.43	\$1.06	\$0.43	\$0.43	\$0.43	\$0.41	\$0.41	\$1.06	\$0.63	\$0.63	\$0.55
Carbon Reduction	2023-2024	Nov	\$0.90	\$0.90	\$1.22	\$0.92	\$1.22	\$0.92	\$0.92	\$0.92	\$0.90	\$0.90	\$1.22	\$1.01	\$1.01	\$0.98
Carbon Reduction	2023-2024	Dec	\$1.20	\$1.10	\$1.22	\$1.23	\$1.28	\$1.23	\$1.23	\$1.23	\$1.20	\$1.10	\$1.22	\$1.18	\$1.18	\$1.24
Carbon Reduction	2023-2024	Jan	\$1.24	\$1.24	\$1.24	\$1.27	\$1.29	\$1.27	\$1.27	\$1.27	\$1.24	\$1.24	\$1.24	\$1.24	\$1.24	\$1.28
Carbon Reduction	2023-2024	Feb	\$1.03	\$0.96	\$1.26	\$0.99	\$1.26	\$0.99	\$0.99	\$0.99	\$1.03	\$0.96	\$1.26	\$1.08	\$1.08	\$1.05
Carbon Reduction	2023-2024	Mar	\$0.91	\$0.91	\$1.17	\$0.93	\$1.17	\$0.93	\$0.93	\$0.93	\$0.91	\$0.91	\$1.17	\$1.00	\$1.00	\$0.98
Carbon Reduction	2023-2024	Apr	\$0.62	\$0.62	\$0.97	\$0.64	\$0.97	\$0.97	\$0.97	\$0.97	\$0.62	\$0.62	\$0.97	\$0.74	\$0.74	\$0.91
Carbon Reduction	2023-2024	May	\$0.61	\$0.61	\$0.95	\$0.63	\$0.95	\$0.63	\$0.63	\$0.63	\$0.61	\$0.61	\$0.95	\$0.72	\$0.72	\$0.69
Carbon Reduction	2023-2024	Jun	\$0.62	\$0.62	\$0.95	\$0.63	\$0.95	\$0.63	\$0.63	\$0.63	\$0.62	\$0.62	\$0.95	\$0.73	\$0.73	\$0.70
Carbon Reduction	2023-2024	Jul	\$0.58	\$0.58	\$0.95	\$0.60	\$0.95	\$0.60	\$0.60	\$0.60	\$0.58	\$0.58	\$0.95	\$0.70	\$0.70	\$0.67
Carbon Reduction	2023-2024	Aug	\$0.58	\$0.58	\$0.95	\$0.59	\$0.95	\$0.59	\$0.59	\$0.59	\$0.58	\$0.58	\$0.95	\$0.70	\$0.70	\$0.67
Carbon Reduction	2023-2024	Sep	\$0.66	\$0.66	\$0.95	\$0.68	\$0.95	\$0.68	\$0.68	\$0.68	\$0.66	\$0.66	\$0.95	\$0.76	\$0.76	\$0.74
Carbon Reduction	2023-2024	Oct	\$0.67	\$0.67	\$0.99	\$0.69	\$0.99	\$0.69	\$0.69	\$0.69	\$0.67	\$0.67	\$0.99	\$0.78	\$0.78	\$0.75
Carbon Reduction	2024-2025	Nov	\$0.79	\$0.79	\$1.16	\$0.81	\$1.16	\$0.81	\$0.81	\$0.81	\$0.79	\$0.79	\$1.16	\$0.91	\$0.91	\$0.88
Carbon Reduction	2024-2025	Dec	\$1.13	\$0.99	\$1.16	\$1.18	\$1.25	\$1.18	\$1.18	\$1.18	\$1.13	\$0.99	\$1.16	\$1.10	\$1.10	\$1.19
Carbon Reduction	2024-2025	Jan	\$1.16	\$1.16	\$1.16	\$1.19	\$1.21	\$1.19	\$1.19	\$1.19	\$1.16	\$1.16	\$1.16	\$1.16	\$1.16	\$1.19
Carbon Reduction	2024-2025	Feb	\$1.10	\$1.06	\$1.18	\$1.10	\$1.22	\$1.10	\$1.10	\$1.10	\$1.10	\$1.06	\$1.18	\$1.11	\$1.11	\$1.12
Carbon Reduction	2024-2025	Mar	\$0.94	\$0.94	\$1.13	\$0.96	\$1.13	\$0.96	\$0.96	\$0.96	\$0.94	\$0.94	\$1.13	\$1.00	\$1.00	\$0.99
Carbon Reduction	2024-2025	Apr	\$0.79	\$0.79	\$1.22	\$0.81	\$1.22	\$1.22	\$1.22	\$1.22	\$0.79	\$0.79	\$1.22	\$0.94	\$0.94	\$1.14
Carbon Reduction	2024-2025	May	\$0.88	\$0.88	\$1.13	\$0.90	\$1.13	\$0.90	\$0.90	\$0.90	\$0.88	\$0.88	\$1.13	\$0.96	\$0.96	\$0.95
Carbon Reduction	2024-2025	Jun	\$0.80	\$0.80	\$1.13	\$0.82	\$1.13	\$0.82	\$0.82	\$0.82	\$0.80	\$0.80	\$1.13	\$0.91	\$0.91	\$0.88
Carbon Reduction	2024-2025	Jul	\$0.78	\$0.78	\$1.13	\$0.81	\$1.13	\$0.81	\$0.81	\$0.81	\$0.78	\$0.78	\$1.13	\$0.90	\$0.90	\$0.87
Carbon Reduction	2024-2025	Aug	\$0.78	\$0.78	\$1.14	\$0.80	\$1.14	\$0.80	\$0.80	\$0.80	\$0.78	\$0.78	\$1.14	\$0.90	\$0.90	\$0.87
Carbon Reduction	2024-2025	Sep	\$0.88	\$0.88	\$1.14	\$0.90	\$1.14	\$0.90	\$0.90	\$0.90	\$0.88	\$0.88	\$1.14	\$0.97	\$0.97	\$0.95
Carbon Reduction	2024-2025	Oct	\$0.88	\$0.88	\$1.48	\$0.90	\$1.48	\$0.90	\$0.90	\$0.90	\$0.88	\$0.88	\$1.48	\$1.08	\$1.08	\$1.02
Carbon Reduction	2025-2026	Nov	\$1.09	\$1.06	\$1.35	\$1.09	\$1.35	\$1.09	\$1.09	\$1.09	\$1.09	\$1.06	\$1.35	\$1.17	\$1.17	\$1.14
Carbon Reduction	2025-2026	Dec	\$1.36	\$1.20	\$1.36	\$1.41	\$1.47	\$1.41	\$1.41	\$1.41	\$1.36	\$1.20	\$1.36	\$1.31	\$1.31	\$1.43
Carbon Reduction	2025-2026	Jan	\$1.38	\$1.38	\$1.38	\$1.41	\$1.44	\$1.41	\$1.41	\$1.41	\$1.38	\$1.38	\$1.38	\$1.38	\$1.38	\$1.42
Carbon Reduction	2025-2026	Feb	\$1.36	\$1.33	\$1.39	\$1.39	\$1.43	\$1.39	\$1.39	\$1.39	\$1.36	\$1.33	\$1.39	\$1.36	\$1.36	\$1.40
Carbon Reduction	2025-2026	Mar	\$1.20</													

Monthly Avoided Costs ¹																
Nominal \$																
Scenario	Gas Year	Month	ID BOH	IDGTN	IDNWP	Klamath Falls	La Grande	Medford GTN	Medford NWP	Roseburg	WA Both	WA GTN	WA NWP	Idaho	Washington	Oregon
Carbon Reduction	2027-2028	Dec	\$1.57	\$1.52	\$1.57	\$1.68	\$1.72	\$1.68	\$1.68	\$1.68	\$1.57	\$1.52	\$1.57	\$1.56	\$1.56	\$1.69
Carbon Reduction	2027-2028	Jan	\$1.58	\$1.57	\$1.58	\$1.61	\$1.63	\$1.61	\$1.61	\$1.61	\$1.58	\$1.57	\$1.58	\$1.57	\$1.57	\$1.61
Carbon Reduction	2027-2028	Feb	\$1.53	\$1.47	\$1.60	\$1.53	\$1.66	\$1.53	\$1.53	\$1.53	\$1.53	\$1.47	\$1.60	\$1.53	\$1.53	\$1.55
Carbon Reduction	2027-2028	Mar	\$1.35	\$1.35	\$1.48	\$1.38	\$1.48	\$1.38	\$1.38	\$1.38	\$1.35	\$1.35	\$1.48	\$1.39	\$1.39	\$1.40
Carbon Reduction	2027-2028	Apr	\$1.11	\$1.11	\$1.48	\$1.14	\$1.48	\$1.48	\$1.48	\$1.48	\$1.11	\$1.11	\$1.48	\$1.23	\$1.23	\$1.41
Carbon Reduction	2027-2028	May	\$1.20	\$1.20	\$1.48	\$1.23	\$1.48	\$1.23	\$1.23	\$1.23	\$1.20	\$1.20	\$1.48	\$1.29	\$1.29	\$1.28
Carbon Reduction	2027-2028	Jun	\$1.18	\$1.18	\$1.48	\$1.21	\$1.48	\$1.21	\$1.21	\$1.21	\$1.18	\$1.18	\$1.48	\$1.28	\$1.28	\$1.26
Carbon Reduction	2027-2028	Jul	\$1.15	\$1.15	\$1.48	\$1.18	\$1.48	\$1.18	\$1.18	\$1.18	\$1.15	\$1.15	\$1.48	\$1.26	\$1.26	\$1.24
Carbon Reduction	2027-2028	Aug	\$1.17	\$1.17	\$1.48	\$1.20	\$1.48	\$1.20	\$1.20	\$1.20	\$1.17	\$1.17	\$1.48	\$1.27	\$1.27	\$1.25
Carbon Reduction	2027-2028	Sep	\$1.24	\$1.24	\$1.48	\$1.26	\$1.48	\$1.26	\$1.26	\$1.26	\$1.24	\$1.24	\$1.48	\$1.32	\$1.32	\$1.31
Carbon Reduction	2027-2028	Oct	\$1.30	\$1.30	\$2.08	\$1.33	\$2.08	\$1.33	\$1.33	\$1.33	\$1.30	\$1.30	\$2.08	\$1.56	\$1.56	\$1.48
Carbon Reduction	2028-2029	Nov	\$1.55	\$1.54	\$1.63	\$1.58	\$1.63	\$1.58	\$1.58	\$1.58	\$1.55	\$1.54	\$1.63	\$1.58	\$1.58	\$1.59
Carbon Reduction	2028-2029	Dec	\$1.64	\$1.56	\$1.64	\$1.77	\$1.81	\$1.77	\$1.77	\$1.77	\$1.64	\$1.56	\$1.64	\$1.61	\$1.61	\$1.78
Carbon Reduction	2028-2029	Jan	\$1.66	\$1.66	\$1.66	\$1.70	\$1.73	\$1.70	\$1.70	\$1.70	\$1.66	\$1.66	\$1.66	\$1.66	\$1.66	\$1.70
Carbon Reduction	2028-2029	Feb	\$1.62	\$1.53	\$1.67	\$1.60	\$1.71	\$1.60	\$1.60	\$1.60	\$1.62	\$1.53	\$1.67	\$1.61	\$1.61	\$1.62
Carbon Reduction	2028-2029	Mar	\$1.40	\$1.40	\$1.55	\$1.43	\$1.55	\$1.43	\$1.43	\$1.43	\$1.40	\$1.40	\$1.55	\$1.45	\$1.45	\$1.45
Carbon Reduction	2028-2029	Apr	\$1.23	\$1.23	\$1.82	\$1.26	\$1.82	\$1.82	\$1.82	\$1.82	\$1.23	\$1.23	\$1.82	\$1.42	\$1.42	\$1.71
Carbon Reduction	2028-2029	May	\$1.27	\$1.27	\$1.51	\$1.30	\$1.51	\$1.30	\$1.30	\$1.30	\$1.27	\$1.27	\$1.51	\$1.35	\$1.35	\$1.34
Carbon Reduction	2028-2029	Jun	\$1.25	\$1.25	\$1.51	\$1.28	\$1.51	\$1.28	\$1.28	\$1.28	\$1.25	\$1.25	\$1.51	\$1.34	\$1.34	\$1.33
Carbon Reduction	2028-2029	Jul	\$1.21	\$1.21	\$1.51	\$1.24	\$1.51	\$1.24	\$1.24	\$1.24	\$1.21	\$1.21	\$1.51	\$1.31	\$1.31	\$1.30
Carbon Reduction	2028-2029	Aug	\$1.20	\$1.20	\$1.52	\$1.23	\$1.52	\$1.23	\$1.23	\$1.23	\$1.20	\$1.20	\$1.52	\$1.31	\$1.31	\$1.29
Carbon Reduction	2028-2029	Sep	\$1.28	\$1.28	\$1.52	\$1.31	\$1.52	\$1.31	\$1.31	\$1.31	\$1.28	\$1.28	\$1.52	\$1.36	\$1.36	\$1.35
Carbon Reduction	2028-2029	Oct	\$1.33	\$1.33	\$2.11	\$1.36	\$2.11	\$1.36	\$1.36	\$1.36	\$1.33	\$1.33	\$2.11	\$1.59	\$1.59	\$1.51
Carbon Reduction	2029-2030	Nov	\$1.61	\$1.60	\$1.67	\$1.64	\$1.67	\$1.64	\$1.64	\$1.64	\$1.61	\$1.60	\$1.67	\$1.63	\$1.63	\$1.64
Carbon Reduction	2029-2030	Dec	\$1.67	\$1.67	\$1.67	\$1.84	\$1.88	\$1.84	\$1.84	\$1.84	\$1.67	\$1.67	\$1.67	\$1.67	\$1.67	\$1.85
Carbon Reduction	2029-2030	Jan	\$1.70	\$1.70	\$1.70	\$1.73	\$1.77	\$1.73	\$1.73	\$1.73	\$1.70	\$1.70	\$1.70	\$1.70	\$1.70	\$1.74
Carbon Reduction	2029-2030	Feb	\$1.67	\$1.58	\$1.71	\$1.65	\$1.75	\$1.65	\$1.65	\$1.65	\$1.67	\$1.58	\$1.71	\$1.65	\$1.65	\$1.67
Carbon Reduction	2029-2030	Mar	\$1.46	\$1.46	\$1.59	\$1.50	\$1.59	\$1.50	\$1.50	\$1.50	\$1.46	\$1.46	\$1.59	\$1.50	\$1.50	\$1.51
Carbon Reduction	2029-2030	Apr	\$1.29	\$1.29	\$1.91	\$1.32	\$1.91	\$1.91	\$1.91	\$1.91	\$1.29	\$1.29	\$1.91	\$1.50	\$1.50	\$1.79
Carbon Reduction	2029-2030	May	\$1.32	\$1.32	\$1.52	\$1.35	\$1.52	\$1.35	\$1.35	\$1.35	\$1.32	\$1.32	\$1.52	\$1.39	\$1.39	\$1.38
Carbon Reduction	2029-2030	Jun	\$1.28	\$1.28	\$1.52	\$1.31	\$1.52	\$1.31	\$1.31	\$1.31	\$1.28	\$1.28	\$1.52	\$1.36	\$1.36	\$1.36
Carbon Reduction	2029-2030	Jul	\$1.20	\$1.20	\$1.53	\$1.22	\$1.53	\$1.22	\$1.22	\$1.22	\$1.20	\$1.20	\$1.53	\$1.31	\$1.31	\$1.28
Carbon Reduction	2029-2030	Aug	\$1.21	\$1.21	\$1.53	\$1.23	\$1.53	\$1.23	\$1.23	\$1.23	\$1.21	\$1.21	\$1.53	\$1.31	\$1.31	\$1.29
Carbon Reduction	2029-2030	Sep	\$1.26	\$1.26	\$1.53	\$1.29	\$1.53	\$1.29	\$1.29	\$1.29	\$1.26	\$1.26	\$1.53	\$1.35	\$1.35	\$1.34
Carbon Reduction	2029-2030	Oct	\$1.37	\$1.37	\$1.99	\$1.40	\$1.99	\$1.40	\$1.40	\$1.40	\$1.37	\$1.37	\$1.99	\$1.58	\$1.58	\$1.52
Carbon Reduction	2030-2031	Nov	\$1.65	\$1.64	\$1.72	\$1.68	\$1.72	\$1.68	\$1.68	\$1.68	\$1.65	\$1.64	\$1.72	\$1.67	\$1.67	\$1.69
Carbon Reduction	2030-2031	Dec	\$1.73	\$1.72	\$1.73	\$1.88	\$1.91	\$1.88	\$1.88	\$1.88	\$1.73	\$1.72	\$1.73	\$1.73	\$1.73	\$1.88
Carbon Reduction	2030-2031	Jan	\$1.73	\$1.73	\$1.73	\$1.76	\$1.79	\$1.76	\$1.76	\$1.76	\$1.73	\$1.73	\$1.73	\$1.73	\$1.73	\$1.77
Carbon Reduction	2030-2031	Feb	\$1.75	\$1.64	\$1.77	\$1.71	\$1.81	\$1.71	\$1.71	\$1.71	\$1.75	\$1.64	\$1.77	\$1.72	\$1.72	\$1.73
Carbon Reduction	2030-2031	Mar	\$1.49	\$1.49	\$1.63	\$1.53	\$1.63	\$1.53	\$1.53	\$1.53	\$1.49	\$1.49	\$1.63	\$1.54	\$1.54	\$1.55
Carbon Reduction	2030-2031	Apr	\$1.35	\$1.35	\$2.01	\$1.38	\$2.01	\$2.01	\$2.01	\$2.01	\$1.35	\$1.35	\$2.01	\$1.57	\$1.57	\$1.88
Carbon Reduction	2030-2031	May	\$1.35	\$1.35	\$1.62	\$1.38	\$1.62	\$1.38	\$1.38	\$1.38	\$1.35	\$1.35	\$1.62	\$1.44	\$1.44	\$1.42
Carbon Reduction	2030-2031	Jun	\$1.31	\$1.31	\$1.62	\$1.34	\$1.62	\$1.34	\$1.34	\$1.34	\$1.31	\$1.31	\$1.62	\$1.41	\$1.41	\$1.39
Carbon Reduction	2030-2031	Jul	\$1.24	\$1.24	\$1.62	\$1.26	\$1.62	\$1.26	\$1.26	\$1.26	\$1.24	\$1.24	\$1.62	\$1.36	\$1.36	\$1.34
Carbon Reduction	2030-2031	Aug	\$1.23	\$1.23	\$1.62	\$1.26	\$1.62	\$1.26	\$1.26	\$1.26	\$1.23	\$1.23	\$1.62	\$1.36	\$1.36	\$1.33
Carbon Reduction	2030-2031	Sep	\$1.34	\$1.34	\$1.62	\$1.37	\$1.62	\$1.37	\$1.37	\$1.37	\$1.34	\$1.34	\$1.62	\$1.44	\$1.44	\$1.42
Carbon Reduction	2030-2031	Oct	\$1.40	\$1.40	\$2.04	\$1.43	\$2.04	\$1.43	\$1.43	\$1.43	\$1.40	\$1.40	\$2.04	\$1.61	\$1.61	\$1.55
Carbon Reduction	2031-2032	Nov	\$1.72	\$1.70	\$1.82	\$1.74	\$1.82	\$1.74	\$1.74	\$1.74	\$1.72	\$1.70	\$1.82	\$1.75	\$1.75	\$1.76
Carbon Reduction	2031-2032	Dec	\$1.83	\$1.73	\$1.83	\$2.41	\$2.42	\$2.41	\$2.41	\$2.41	\$1.83	\$1.73	\$1.83	\$1.80	\$1.80	\$2.41
Carbon Reduction	2031-2032	Jan	\$1.83	\$1.74	\$1.83	\$1.78	\$1.86	\$1.78	\$1.78	\$1.78	\$1.83	\$1.74	\$1.83	\$1.80	\$1.80	\$1.79
Carbon Reduction	2031-2032	Feb	\$1.82	\$1.63	\$1.87	\$1.70	\$1.93	\$1.70	\$1.70	\$1.70	\$1.82	\$1.63	\$1.87	\$1.77	\$1.77	\$1.74
Carbon Reduction	2031-2032	Mar	\$1.51	\$1.51	\$1.74	\$1.54	\$1.74	\$1.54	\$1.54	\$1.54	\$1.51	\$1.51	\$1.74	\$1.59	\$1.59	\$1.58
Carbon Reduction	2031-2032	Apr	\$1.39	\$1.39	\$2.07	\$1.42	\$2.07	\$2.07	\$2.07	\$2.07	\$1.39	\$1.39	\$2.07	\$1.62	\$1.62	\$1.94
Carbon Reduction	2031-2032	May	\$1.37	\$1.37	\$1.60	\$1.40	\$1.60	\$1.40	\$1.40	\$1.40	\$1.37	\$1.37	\$1.60	\$1.44	\$1.44	\$1.44
Carbon Reduction	2031-2032	Jun	\$1.30	\$1.30	\$1.60	\$1.33	\$1.60	\$1.33	\$1.33	\$1.33	\$1.30	\$1.30	\$1.60	\$1.40	\$1.40	\$1.39
Carbon Reduction	2031-2032	Jul	\$1.09	\$1.09	\$1.60	\$1.11	\$1.60	\$1.11	\$1.11	\$1.11	\$1.09	\$1.09	\$1.60	\$1.26	\$1.26	\$1.21
Carbon Reduction	2031-2032	Aug	\$1.09	\$1.09	\$1.60	\$1.11	\$1.60	\$1.11	\$1.11	\$1.11	\$1.09	\$1.09	\$1.60	\$1.26	\$1.26	\$1.21
Carbon Reduction	2031-2032	Sep	\$1.28	\$1.28	\$1.60	\$1.31	\$1.60	\$1.31	\$1.31	\$1.31	\$1.28	\$1.28	\$1.60	\$1.39	\$1.39	\$1.37
Carbon Reduction	2031-2032	Oct	\$1.39	\$1.39	\$2.04	\$1.42	\$2.04	\$2.04	\$2.04	\$2.04	\$1.39	\$1.39	\$2.04	\$1.60	\$1.60	\$1.91
Carbon Reduction	2032-2033	Nov	\$1.76	\$1.72	\$1.94	\$1.75	\$1.94	\$1.75	\$1.75	\$1.75	\$1.76	\$1.72	\$1.94	\$1.81	\$1.81	\$1.79
Carbon Reduction	2032-2033	Dec	\$1.97	\$1.79	\$1.97	\$2.52	\$2.53	\$2.52	\$2.52	\$2.52	\$1.97	\$1.79	\$1.97	\$1.91	\$1.91	\$2.52
Carbon Reduction	2032-2033	Jan	\$1.95	\$1.84	\$1.95	\$1.88	\$2.07	\$1.88	\$1.88	\$1.88	\$1.95	\$1.84	\$1.95	\$1.92	\$1.92	\$1.92
Carbon Reduction	2032-2033	Feb	\$1.95	\$1.80	\$1.99	\$1.87	\$2.04	\$1.87	\$1.87	\$1.87	\$1.95	\$1.80	\$1.99	\$1.92	\$1.92	\$1.90
Carbon Reduction	2032-2033	Mar	\$1.68	\$1.68	\$1.87	\$1.72	\$1.87	\$1.72	\$1.72	\$1.72	\$1.68	\$1.68	\$1.87	\$1.75	\$1.75	\$1.75
Carbon Reduction	2032-2033	Apr	\$1.56	\$1.56	\$2.21	\$1.59	\$2.21	\$2.21	\$2.21	\$2.21	\$1.56	\$1.56	\$2.21	\$1.77	\$1.77	\$2.08
Carbon Reduction	2032-2033	May	\$1.52	\$1.52	\$1.78	\$1.56	\$1.78	\$1.56	\$1.56	\$1.56	\$1.52	\$1.52	\$1.78	\$1.61	\$1.61	\$1.60
Carbon Reduction	2032-2033	Jun	\$1.52	\$1.52	\$1.78	\$1.55	\$1.78	\$1.55	\$1.55	\$1.55	\$1.52	\$1.52	\$1.78	\$1.61	\$1.61	\$1.60
Carbon Reduction	2032-2033	Jul	\$1.34	\$1.34	\$1.78	\$1.37	\$1.78	\$1.37	\$1.37	\$1.37	\$1.34	\$1.34	\$1.78	\$1.49	\$1.49	\$1.46
Carbon Reduction	2032-2033	Aug	\$1.36	\$1.36	\$1.78	\$1.39	\$1.78	\$1.39	\$1.39	\$1.39	\$1.36	\$1.36	\$1.78	\$1.50	\$1.50	\$1.47
Carbon Reduction	2032-2033	Sep	\$1.50	\$1.50	\$1.78	\$1.53	\$1.78	\$1.53	\$1.53	\$1.53	\$1.50	\$1.50	\$1.78	\$1.59	\$1.59	\$1.58
Carbon Reduction	2032-2033	Oct	\$1.58	\$1.58	\$2.21	\$1.61	\$2.21	\$2.21	\$2.21	\$2.21	\$1.58	\$1.58	\$2.21	\$1.79	\$1.79	\$2.09
Carbon Reduction	2033-2034	Nov	\$1.98	\$1.94	\$2.18	\$1.98	\$2.18	\$1.98	\$1.98	\$1.98	\$1.98	\$1.94	\$2.18	\$2.03	\$2.03	\$2.02
Carbon Reduction	2033-2034	Dec	\$2.20	\$1.93	\$2.20	\$2.72	\$2.74	\$2.72	\$2.72	\$2.72	\$2.20	\$1.93	\$2.20	\$2.11	\$2.11	\$2.72
Carbon Reduction	2033-2034	Jan	\$2.19	\$1.97	\$2.19	\$2.01	\$2.31	\$2.01	\$2.01	\$2.01	\$2.19	\$1.97	\$2.19	\$2.12	\$2.12	\$2.07
Carbon Reduction	2033-2034	Feb	\$2.15	\$1.88	\$2.23	\$1.94	\$2.26	\$1.94	\$1.94	\$1.94	\$2.15	\$1.88	\$2.23	\$2.09	\$2.09	\$2.00
Carbon Reduction	2033-2034	Mar	\$1.77	\$1.77	\$2.11	\$1.81	\$2.11	\$1.81	\$1.81	\$1.81	\$1.77	\$1.77	\$2.11	\$1.89	\$1.89	\$1.87
Carbon Reduction	2033-2034	Apr	\$1.65	\$1.65	\$2.30	\$1.68	\$2.30	\$2.30	\$2.30	\$						

Monthly Avoided Costs ¹																
Scenario	Gas Year	Month	Nominal \$													
			ID Both	ID GTN	ID NWP	Klamath Falls	La Grande	Medford GTN	Medford NWP	Roseburg	WA Both	WA GTN	WA NWP	Idaho	Washington	Oregon
Carbon Reduction	2035-2036	Jan	\$2.52	\$2.10	\$2.52	\$2.14	\$2.61	\$2.14	\$2.14	\$2.14	\$2.52	\$2.10	\$2.52	\$2.38	\$2.38	\$2.23
Carbon Reduction	2035-2036	Feb	\$2.53	\$2.07	\$2.56	\$2.15	\$2.59	\$2.15	\$2.15	\$2.15	\$2.53	\$2.07	\$2.56	\$2.39	\$2.39	\$2.24
Carbon Reduction	2035-2036	Mar	\$1.92	\$1.92	\$2.46	\$1.96	\$2.46	\$1.96	\$1.96	\$1.96	\$1.92	\$1.92	\$2.46	\$2.10	\$2.10	\$2.06
Carbon Reduction	2035-2036	Apr	\$1.72	\$1.72	\$2.27	\$1.75	\$2.27	\$2.27	\$2.27	\$2.27	\$1.72	\$1.72	\$2.27	\$1.90	\$1.90	\$2.16
Carbon Reduction	2035-2036	May	\$1.72	\$1.72	\$1.96	\$1.75	\$1.96	\$1.75	\$1.75	\$1.75	\$1.72	\$1.72	\$1.96	\$1.80	\$1.80	\$1.79
Carbon Reduction	2035-2036	Jun	\$1.67	\$1.67	\$1.96	\$1.71	\$1.96	\$1.71	\$1.71	\$1.71	\$1.67	\$1.67	\$1.96	\$1.77	\$1.77	\$1.76
Carbon Reduction	2035-2036	Jul	\$1.40	\$1.40	\$1.96	\$1.43	\$1.96	\$1.43	\$1.43	\$1.43	\$1.40	\$1.40	\$1.96	\$1.59	\$1.59	\$1.54
Carbon Reduction	2035-2036	Aug	\$1.44	\$1.44	\$1.96	\$1.47	\$1.96	\$1.47	\$1.47	\$1.47	\$1.44	\$1.44	\$1.96	\$1.61	\$1.61	\$1.57
Carbon Reduction	2035-2036	Sep	\$1.60	\$1.60	\$1.96	\$1.64	\$1.96	\$1.64	\$1.64	\$1.64	\$1.60	\$1.60	\$1.96	\$1.72	\$1.72	\$1.70
Carbon Reduction	2035-2036	Oct	\$1.77	\$1.77	\$2.34	\$1.80	\$2.34	\$2.34	\$2.34	\$2.34	\$1.77	\$1.77	\$2.34	\$1.96	\$1.96	\$2.23
Carbon Reduction	2036-2037	Nov	\$2.24	\$2.11	\$2.56	\$2.15	\$2.56	\$2.15	\$2.15	\$2.15	\$2.24	\$2.11	\$2.56	\$2.30	\$2.30	\$2.23
Carbon Reduction	2036-2037	Dec	\$2.59	\$2.15	\$2.59	\$3.15	\$3.16	\$3.15	\$3.15	\$3.15	\$2.59	\$2.15	\$2.59	\$2.44	\$2.44	\$3.15
Carbon Reduction	2036-2037	Jan	\$2.59	\$2.17	\$2.59	\$2.21	\$2.69	\$2.21	\$2.21	\$2.21	\$2.59	\$2.17	\$2.59	\$2.45	\$2.45	\$2.31
Carbon Reduction	2036-2037	Feb	\$2.48	\$1.99	\$2.61	\$2.04	\$2.64	\$2.04	\$2.04	\$2.04	\$2.48	\$1.99	\$2.61	\$2.36	\$2.36	\$2.16
Carbon Reduction	2036-2037	Mar	\$1.87	\$1.87	\$2.54	\$1.91	\$2.54	\$1.91	\$1.91	\$1.91	\$1.87	\$1.87	\$2.54	\$2.09	\$2.09	\$2.04
Carbon Reduction	2036-2037	Apr	\$1.67	\$1.67	\$2.24	\$1.71	\$2.24	\$2.24	\$2.24	\$2.24	\$1.67	\$1.67	\$2.24	\$1.86	\$1.86	\$2.13
Carbon Reduction	2036-2037	May	\$1.80	\$1.80	\$2.05	\$1.84	\$2.05	\$1.84	\$1.84	\$1.84	\$1.80	\$1.80	\$2.05	\$1.89	\$1.89	\$1.88
Carbon Reduction	2036-2037	Jun	\$1.77	\$1.77	\$2.05	\$1.80	\$2.05	\$1.80	\$1.80	\$1.80	\$1.77	\$1.77	\$2.05	\$1.86	\$1.86	\$1.85
Carbon Reduction	2036-2037	Jul	\$1.54	\$1.54	\$2.05	\$1.58	\$2.05	\$1.58	\$1.58	\$1.58	\$1.54	\$1.54	\$2.05	\$1.71	\$1.71	\$1.67
Carbon Reduction	2036-2037	Aug	\$1.61	\$1.61	\$2.05	\$1.64	\$2.05	\$1.64	\$1.64	\$1.64	\$1.61	\$1.61	\$2.05	\$1.76	\$1.76	\$1.73
Carbon Reduction	2036-2037	Sep	\$1.74	\$1.74	\$2.05	\$1.78	\$2.05	\$1.78	\$1.78	\$1.78	\$1.74	\$1.74	\$2.05	\$1.85	\$1.85	\$1.84
Carbon Reduction	2036-2037	Oct	\$1.89	\$1.89	\$2.45	\$1.93	\$2.45	\$2.45	\$2.45	\$2.45	\$1.89	\$1.89	\$2.45	\$2.07	\$2.07	\$2.35
Carbon Reduction	2037-2038	Nov	\$2.41	\$2.28	\$2.79	\$2.32	\$2.79	\$2.32	\$2.32	\$2.32	\$2.41	\$2.28	\$2.79	\$2.49	\$2.49	\$2.41
Carbon Reduction	2037-2038	Dec	\$2.82	\$2.38	\$2.82	\$3.28	\$3.30	\$3.28	\$3.28	\$3.28	\$2.82	\$2.38	\$2.82	\$2.68	\$2.68	\$3.29
Carbon Reduction	2037-2038	Jan	\$2.82	\$2.40	\$2.82	\$2.45	\$2.91	\$2.45	\$2.45	\$2.45	\$2.82	\$2.40	\$2.82	\$2.68	\$2.68	\$2.54
Carbon Reduction	2037-2038	Feb	\$2.68	\$2.17	\$2.83	\$2.25	\$2.85	\$2.25	\$2.25	\$2.25	\$2.68	\$2.17	\$2.83	\$2.56	\$2.56	\$2.37
Carbon Reduction	2037-2038	Mar	\$2.01	\$2.01	\$2.83	\$2.05	\$2.83	\$2.05	\$2.05	\$2.05	\$2.01	\$2.01	\$2.83	\$2.28	\$2.28	\$2.21
Carbon Reduction	2037-2038	Apr	\$1.84	\$1.84	\$2.38	\$1.88	\$2.38	\$2.38	\$2.38	\$2.38	\$1.84	\$1.84	\$2.38	\$2.02	\$2.02	\$2.28
Carbon Reduction	2037-2038	May	\$1.87	\$1.87	\$2.10	\$1.90	\$2.10	\$1.90	\$1.90	\$1.90	\$1.87	\$1.87	\$2.10	\$1.94	\$1.94	\$1.94
Carbon Reduction	2037-2038	Jun	\$1.86	\$1.86	\$2.10	\$1.90	\$2.10	\$1.90	\$1.90	\$1.90	\$1.86	\$1.86	\$2.10	\$1.94	\$1.94	\$1.94
Carbon Reduction	2037-2038	Jul	\$1.62	\$1.62	\$2.10	\$1.65	\$2.10	\$1.65	\$1.65	\$1.65	\$1.62	\$1.62	\$2.10	\$1.78	\$1.78	\$1.74
Carbon Reduction	2037-2038	Aug	\$1.62	\$1.62	\$2.10	\$1.65	\$2.10	\$1.65	\$1.65	\$1.65	\$1.62	\$1.62	\$2.10	\$1.78	\$1.78	\$1.74
Carbon Reduction	2037-2038	Sep	\$1.73	\$1.73	\$2.10	\$1.77	\$2.10	\$1.77	\$1.77	\$1.77	\$1.73	\$1.73	\$2.10	\$1.85	\$1.85	\$1.83
Carbon Reduction	2037-2038	Oct	\$1.86	\$1.86	\$2.42	\$1.90	\$2.42	\$2.42	\$2.42	\$2.42	\$1.86	\$1.86	\$2.42	\$2.05	\$2.05	\$2.31
Carbon Reduction	2038-2039	Nov	\$2.36	\$2.23	\$2.74	\$2.27	\$2.74	\$2.27	\$2.27	\$2.27	\$2.36	\$2.23	\$2.74	\$2.45	\$2.45	\$2.37
Carbon Reduction	2038-2039	Dec	\$2.79	\$2.34	\$2.79	\$3.31	\$3.34	\$3.31	\$3.31	\$3.31	\$2.79	\$2.34	\$2.79	\$2.64	\$2.64	\$3.31
Carbon Reduction	2038-2039	Jan	\$2.78	\$2.39	\$2.78	\$2.44	\$2.89	\$2.44	\$2.44	\$2.44	\$2.78	\$2.39	\$2.78	\$2.65	\$2.65	\$2.53
Carbon Reduction	2038-2039	Feb	\$2.73	\$2.21	\$2.80	\$2.29	\$2.82	\$2.29	\$2.29	\$2.29	\$2.73	\$2.21	\$2.80	\$2.58	\$2.58	\$2.40
Carbon Reduction	2038-2039	Mar	\$2.15	\$2.15	\$2.74	\$2.19	\$2.74	\$2.19	\$2.19	\$2.19	\$2.15	\$2.15	\$2.74	\$2.34	\$2.34	\$2.30
Carbon Reduction	2038-2039	Apr	\$1.96	\$1.96	\$2.50	\$2.00	\$2.50	\$2.50	\$2.50	\$2.50	\$1.96	\$1.96	\$2.50	\$2.14	\$2.14	\$2.40
Carbon Reduction	2038-2039	May	\$1.99	\$1.99	\$2.23	\$2.03	\$2.23	\$2.03	\$2.03	\$2.03	\$1.99	\$1.99	\$2.23	\$2.07	\$2.07	\$2.07
Carbon Reduction	2038-2039	Jun	\$1.89	\$1.89	\$2.23	\$1.93	\$2.23	\$1.93	\$1.93	\$1.93	\$1.89	\$1.89	\$2.23	\$2.00	\$2.00	\$1.99
Carbon Reduction	2038-2039	Jul	\$1.68	\$1.68	\$2.23	\$1.72	\$2.23	\$1.72	\$1.72	\$1.72	\$1.68	\$1.68	\$2.23	\$1.87	\$1.87	\$1.82
Carbon Reduction	2038-2039	Aug	\$1.67	\$1.67	\$2.23	\$1.71	\$2.23	\$1.71	\$1.71	\$1.71	\$1.67	\$1.67	\$2.23	\$1.86	\$1.86	\$1.81
Carbon Reduction	2038-2039	Sep	\$1.86	\$1.86	\$2.23	\$1.90	\$2.23	\$1.90	\$1.90	\$1.90	\$1.86	\$1.86	\$2.23	\$1.99	\$1.99	\$1.97
Carbon Reduction	2038-2039	Oct	\$2.01	\$2.01	\$2.57	\$2.05	\$2.57	\$2.57	\$2.57	\$2.57	\$2.01	\$2.01	\$2.57	\$2.20	\$2.20	\$2.47
Carbon Reduction	2039-2040	Nov	\$2.57	\$2.43	\$2.90	\$2.48	\$2.90	\$2.48	\$2.48	\$2.48	\$2.57	\$2.43	\$2.90	\$2.63	\$2.63	\$2.56
Carbon Reduction	2039-2040	Dec	\$2.95	\$2.50	\$2.95	\$3.54	\$3.57	\$3.54	\$3.54	\$3.54	\$2.95	\$2.50	\$2.95	\$2.80	\$2.80	\$3.55
Carbon Reduction	2039-2040	Jan	\$2.95	\$2.50	\$2.95	\$2.55	\$3.08	\$2.55	\$2.55	\$2.55	\$2.95	\$2.50	\$2.95	\$2.80	\$2.80	\$2.66
Carbon Reduction	2039-2040	Feb	\$2.90	\$2.37	\$2.97	\$2.44	\$2.99	\$2.44	\$2.44	\$2.44	\$2.90	\$2.37	\$2.97	\$2.74	\$2.74	\$2.55
Carbon Reduction	2039-2040	Mar	\$2.25	\$2.25	\$2.85	\$2.30	\$2.85	\$2.30	\$2.30	\$2.30	\$2.25	\$2.25	\$2.85	\$2.45	\$2.45	\$2.41
Carbon Reduction	2039-2040	Apr	\$2.07	\$2.07	\$2.62	\$2.11	\$2.62	\$2.62	\$2.62	\$2.62	\$2.07	\$2.07	\$2.62	\$2.25	\$2.25	\$2.52
Carbon Reduction	2039-2040	May	\$2.09	\$2.09	\$2.32	\$2.13	\$2.32	\$2.13	\$2.13	\$2.13	\$2.09	\$2.09	\$2.32	\$2.16	\$2.16	\$2.17
Carbon Reduction	2039-2040	Jun	\$2.06	\$2.06	\$2.32	\$2.10	\$2.32	\$2.10	\$2.10	\$2.10	\$2.06	\$2.06	\$2.32	\$2.14	\$2.14	\$2.14
Carbon Reduction	2039-2040	Jul	\$1.87	\$1.87	\$2.32	\$1.91	\$2.32	\$1.91	\$1.91	\$1.91	\$1.87	\$1.87	\$2.32	\$2.02	\$2.02	\$1.99
Carbon Reduction	2039-2040	Aug	\$1.88	\$1.88	\$2.32	\$1.92	\$2.32	\$1.92	\$1.92	\$1.92	\$1.88	\$1.88	\$2.32	\$2.03	\$2.03	\$2.00
Carbon Reduction	2039-2040	Sep	\$2.03	\$2.03	\$2.32	\$2.07	\$2.32	\$2.07	\$2.07	\$2.07	\$2.03	\$2.03	\$2.32	\$2.13	\$2.13	\$2.12
Carbon Reduction	2039-2040	Oct	\$2.14	\$2.14	\$2.69	\$2.18	\$2.69	\$2.69	\$2.69	\$2.69	\$2.14	\$2.14	\$2.69	\$2.32	\$2.32	\$2.59

¹Avoided costs are before Environmental Externalities added

APPENDIX 7.1: HIGH GROWTH CASES SELECTED RESOURCES VS. PEAK DAY DEMAND EXISTING PLUS EXPECTED AVAILABLE

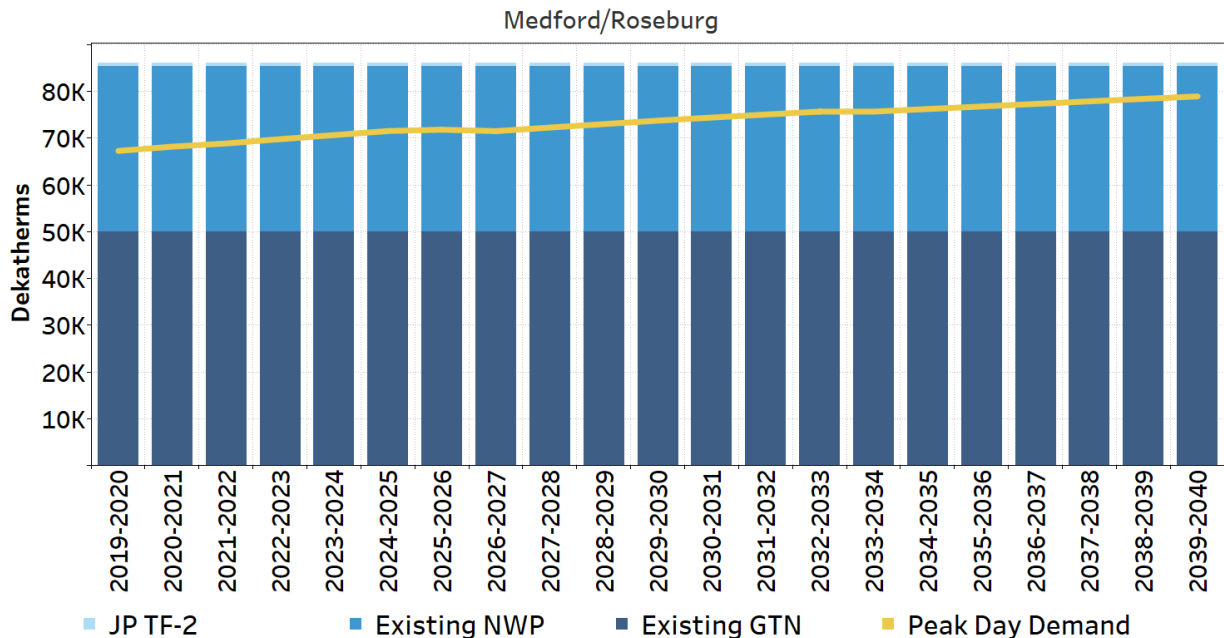
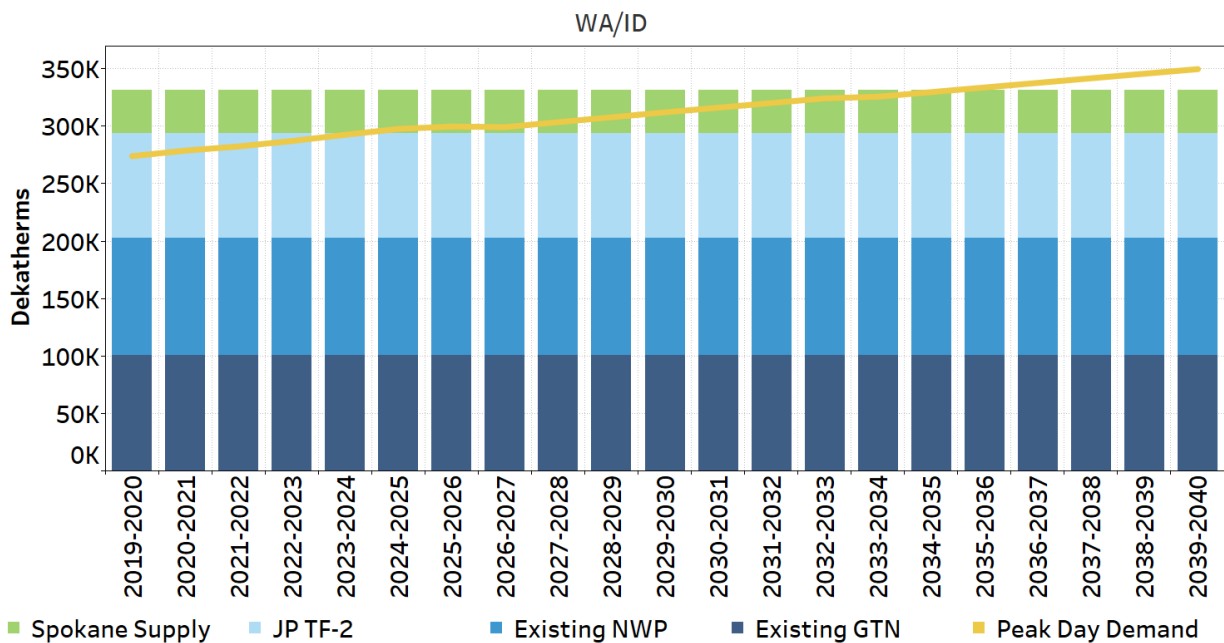

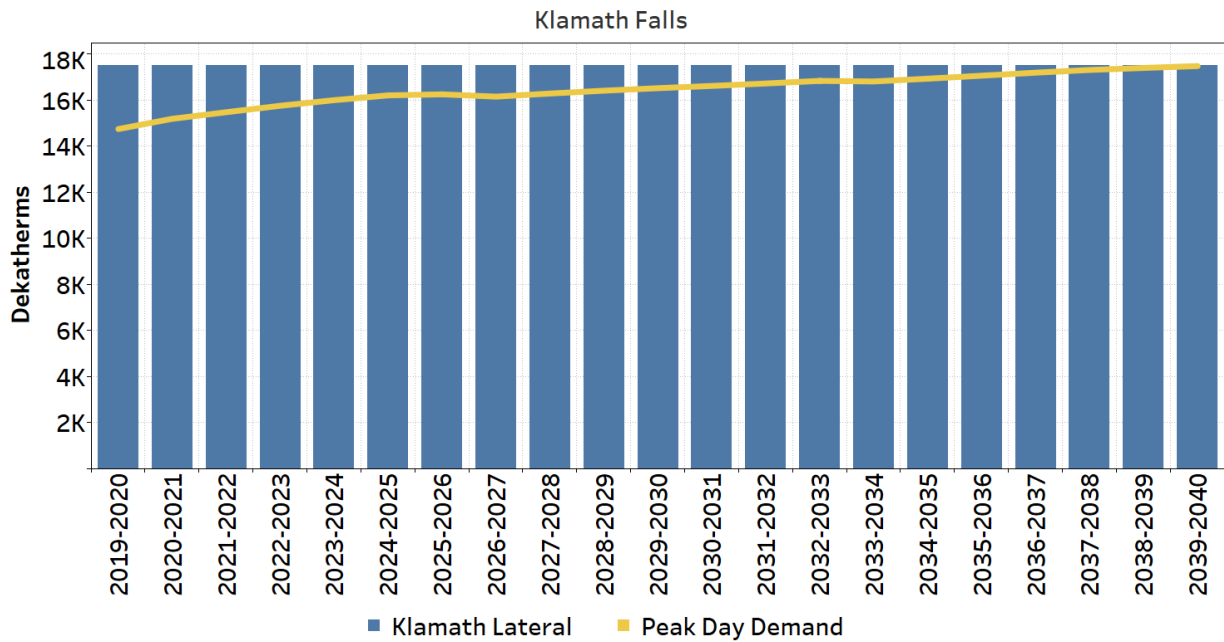
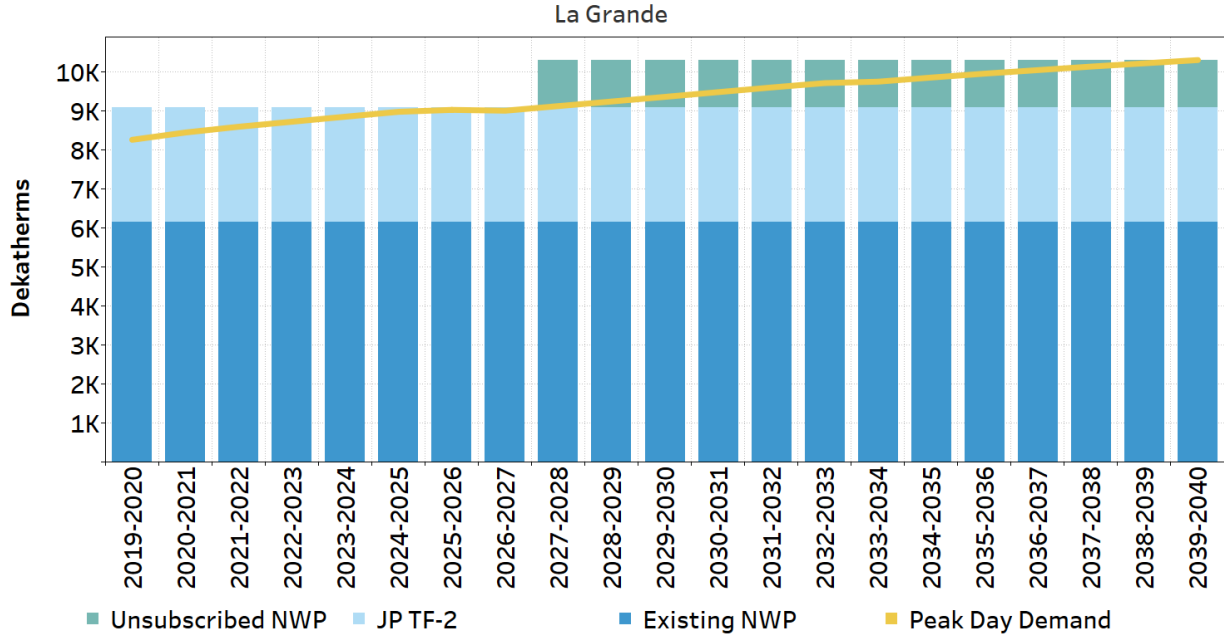

APPENDIX 7.2: PEAK DAY DEMAND TABLE HIGH GROWTH & LOW PRICES

Peak Day Demand - Served and Unserved (MDth/day)													
Before Resource Additions & Net of DSM Savings													
Scenario	Gas Year	La Grande				Klamath Falls				Medord/Roseburg			
		Served	Unserved	Total	% of Peak Day Served	Served	Unserved	Total	% of Peak Day Served	Served	Unserved	Total	% of Peak Day Served
High Growth & Low Prices	2019-2020	8.27	0.00	8.27	100%	14.74	0.00	14.74	100%	67.27	0.00	67.27	100%
High Growth & Low Prices	2020-2021	8.45	0.00	8.45	100%	15.18	0.00	15.18	100%	68.19	0.00	68.19	100%
High Growth & Low Prices	2021-2022	8.60	0.00	8.60	100%	15.47	0.00	15.47	100%	68.87	0.00	68.87	100%
High Growth & Low Prices	2022-2023	8.73	0.00	8.73	100%	15.75	0.00	15.75	100%	69.79	0.00	69.79	100%
High Growth & Low Prices	2023-2024	8.86	0.00	8.86	100%	15.99	0.00	15.99	100%	70.66	0.00	70.66	100%
High Growth & Low Prices	2024-2025	8.99	0.00	8.99	100%	16.20	0.00	16.20	100%	71.53	0.00	71.53	100%
High Growth & Low Prices	2025-2026	9.04	0.00	9.04	100%	16.24	0.00	16.24	100%	71.81	0.00	71.81	100%
High Growth & Low Prices	2026-2027	9.01	0.00	9.01	100%	16.14	0.00	16.14	100%	71.50	0.00	71.50	100%
High Growth & Low Prices	2027-2028	9.13	0.00	9.13	100%	16.28	0.00	16.28	100%	72.27	0.00	72.27	100%
High Growth & Low Prices	2028-2029	9.25	0.00	9.25	100%	16.40	0.00	16.40	100%	73.01	0.00	73.01	100%
High Growth & Low Prices	2029-2030	9.37	0.00	9.37	100%	16.51	0.00	16.51	100%	73.75	0.00	73.75	100%
High Growth & Low Prices	2030-2031	9.49	0.00	9.49	100%	16.61	0.00	16.61	100%	74.41	0.00	74.41	100%
High Growth & Low Prices	2031-2032	9.61	0.00	9.61	100%	16.71	0.00	16.71	100%	75.06	0.00	75.06	100%
High Growth & Low Prices	2032-2033	9.72	0.00	9.72	100%	16.82	0.00	16.82	100%	75.69	0.00	75.69	100%
High Growth & Low Prices	2033-2034	9.76	0.00	9.76	100%	16.80	0.00	16.80	100%	75.68	0.00	75.68	100%
High Growth & Low Prices	2034-2035	9.87	0.00	9.87	100%	16.92	0.00	16.92	100%	76.24	0.00	76.24	100%
High Growth & Low Prices	2035-2036	9.97	0.00	9.97	100%	17.05	0.00	17.05	100%	76.78	0.00	76.78	100%
High Growth & Low Prices	2036-2037	10.06	0.00	10.06	100%	17.18	0.00	17.18	100%	77.33	0.00	77.33	100%
High Growth & Low Prices	2037-2038	10.15	0.00	10.15	100%	17.30	0.00	17.30	100%	77.88	0.00	77.88	100%
High Growth & Low Prices	2038-2039	10.23	0.00	10.23	100%	17.39	0.00	17.39	100%	78.41	0.00	78.41	100%
High Growth & Low Prices	2039-2040	10.25	0.07	10.31	99%	17.47	0.00	17.47	100%	78.93	0.00	78.93	100%

Peak Day Demand - Served and Unserved (MDth/day)										
Before Resource Additions & Net of DSM Savings										
Scenario	Gas Year	WA				ID				
		Served	Unserved	Total	% of Peak Day Served	Served	Unserved	Total	% of Peak Day Served	ID
High Growth & Low Prices	2019-2020	178.46	0.00	178.46	100%	95.47	0.00	95.47	100%	
High Growth & Low Prices	2020-2021	181.18	0.00	181.18	100%	97.59	0.00	97.59	100%	
High Growth & Low Prices	2021-2022	183.28	0.00	183.28	100%	99.12	0.00	99.12	100%	
High Growth & Low Prices	2022-2023	185.92	0.00	185.92	100%	101.21	0.00	101.21	100%	
High Growth & Low Prices	2023-2024	188.92	0.00	188.92	100%	103.63	0.00	103.63	100%	
High Growth & Low Prices	2024-2025	191.80	0.00	191.80	100%	105.87	0.00	105.87	100%	
High Growth & Low Prices	2025-2026	192.93	0.00	192.93	100%	106.79	0.00	106.79	100%	
High Growth & Low Prices	2026-2027	192.49	0.00	192.49	100%	106.73	0.00	106.73	100%	
High Growth & Low Prices	2027-2028	195.13	0.00	195.13	100%	108.40	0.00	108.40	100%	
High Growth & Low Prices	2028-2029	197.74	0.00	197.74	100%	110.05	0.00	110.05	100%	
High Growth & Low Prices	2029-2030	200.36	0.00	200.36	100%	111.72	0.00	111.72	100%	
High Growth & Low Prices	2030-2031	202.70	0.00	202.70	100%	113.43	0.00	113.43	100%	
High Growth & Low Prices	2031-2032	204.99	0.00	204.99	100%	115.19	0.00	115.19	100%	
High Growth & Low Prices	2032-2033	207.26	0.00	207.26	100%	116.97	0.00	116.97	100%	
High Growth & Low Prices	2033-2034	207.83	0.00	207.83	100%	117.86	0.00	117.86	100%	
High Growth & Low Prices	2034-2035	209.96	0.00	209.96	100%	119.71	0.00	119.71	100%	
High Growth & Low Prices	2035-2036	212.06	0.05	212.11	100%	121.56	0.05	121.61	100%	
High Growth & Low Prices	2036-2037	212.28	1.93	214.21	99%	121.58	1.93	123.51	98%	
High Growth & Low Prices	2037-2038	212.45	3.81	216.27	98%	121.64	3.81	125.45	97%	
High Growth & Low Prices	2038-2039	212.60	5.69	218.28	97%	121.74	5.69	127.42	96%	
High Growth & Low Prices	2039-2040	212.76	7.52	220.27	97%	121.89	7.52	129.40	94%	

APPENDIX 7.2: PEAK DAY DEMAND TABLE LOW GROWTH & HIGH PRICES

Peak Day Demand - Served and Unserved (MDth/day) Before Resource Additions & Net of DSM Savings													
Scenario	Gas Year	La Grande				Klamath Falls				Medord/Roseburg			
		Served	Unserved	Total	% of Peak Day Served	Served	Unserved	Total	% of Peak Day Served	Served	Unserved	Total	% of Peak Day Served
Low Growth & High Prices	2019-2020	8.27	0.00	8.27	100%	14.74	0.00	14.74	100%	67.27	0.00	67.27	100%
Low Growth & High Prices	2020-2021	8.13	0.00	8.13	100%	14.49	0.00	14.49	100%	67.54	0.00	67.54	100%
Low Growth & High Prices	2021-2022	3.75	0.00	3.75	100%	6.37	0.00	6.37	100%	31.28	0.00	31.28	100%
Low Growth & High Prices	2022-2023	3.70	0.00	3.70	100%	6.28	0.00	6.28	100%	31.14	0.00	31.14	100%
Low Growth & High Prices	2023-2024	3.69	0.00	3.69	100%	6.29	0.00	6.29	100%	31.37	0.00	31.37	100%
Low Growth & High Prices	2024-2025	3.68	0.00	3.68	100%	6.29	0.00	6.29	100%	31.56	0.00	31.56	100%
Low Growth & High Prices	2025-2026	3.66	0.00	3.66	100%	6.30	0.00	6.30	100%	31.79	0.00	31.79	100%
Low Growth & High Prices	2026-2027	3.65	0.00	3.65	100%	6.31	0.00	6.31	100%	31.96	0.00	31.96	100%
Low Growth & High Prices	2027-2028	3.64	0.00	3.64	100%	6.32	0.00	6.32	100%	32.09	0.00	32.09	100%
Low Growth & High Prices	2028-2029	3.63	0.00	3.63	100%	6.33	0.00	6.33	100%	32.22	0.00	32.22	100%
Low Growth & High Prices	2029-2030	3.61	0.00	3.61	100%	6.36	0.00	6.36	100%	32.38	0.00	32.38	100%
Low Growth & High Prices	2030-2031	3.60	0.00	3.60	100%	6.38	0.00	6.38	100%	32.51	0.00	32.51	100%
Low Growth & High Prices	2031-2032	3.59	0.00	3.59	100%	6.40	0.00	6.40	100%	32.66	0.00	32.66	100%
Low Growth & High Prices	2032-2033	3.59	0.00	3.59	100%	6.43	0.00	6.43	100%	32.79	0.00	32.79	100%
Low Growth & High Prices	2033-2034	3.58	0.00	3.58	100%	6.46	0.00	6.46	100%	32.94	0.00	32.94	100%
Low Growth & High Prices	2034-2035	3.58	0.00	3.58	100%	6.49	0.00	6.49	100%	33.06	0.00	33.06	100%
Low Growth & High Prices	2035-2036	3.58	0.00	3.58	100%	6.51	0.00	6.51	100%	33.19	0.00	33.19	100%
Low Growth & High Prices	2036-2037	3.58	0.00	3.58	100%	6.54	0.00	6.54	100%	33.33	0.00	33.33	100%
Low Growth & High Prices	2037-2038	3.59	0.00	3.59	100%	6.58	0.00	6.58	100%	33.48	0.00	33.48	100%
Low Growth & High Prices	2038-2039	3.59	0.00	3.59	100%	6.61	0.00	6.61	100%	33.61	0.00	33.61	100%
Low Growth & High Prices	2039-2040	3.61	0.00	3.61	100%	6.65	0.00	6.65	100%	33.73	0.00	33.73	100%

Peak Day Demand - Served and Unserved (MDth/day) Before Resource Additions & Net of DSM Savings									
Scenario	Gas Year	WA				ID			
		Served	Unserved	Total	% of Peak Day Served	Served	Unserved	Total	% of Peak Day Served
Low Growth & High Prices	2019-2020	178.46	0.00	178.46	100%	95.47	0.00	95.47	100%
Low Growth & High Prices	2020-2021	177.97	0.00	177.97	100%	94.85	0.00	94.85	100%
Low Growth & High Prices	2021-2022	79.56	0.00	79.56	100%	42.55	0.00	42.55	100%
Low Growth & High Prices	2022-2023	78.90	0.00	78.90	100%	42.11	0.00	42.11	100%
Low Growth & High Prices	2023-2024	79.53	0.00	79.53	100%	42.52	0.00	42.52	100%
Low Growth & High Prices	2024-2025	79.79	0.00	79.79	100%	42.60	0.00	42.60	100%
Low Growth & High Prices	2025-2026	80.15	0.00	80.15	100%	42.70	0.00	42.70	100%
Low Growth & High Prices	2026-2027	80.54	0.00	80.54	100%	42.79	0.00	42.79	100%
Low Growth & High Prices	2027-2028	80.99	0.00	80.99	100%	42.93	0.00	42.93	100%
Low Growth & High Prices	2028-2029	81.32	0.00	81.32	100%	43.01	0.00	43.01	100%
Low Growth & High Prices	2029-2030	81.74	0.00	81.74	100%	43.09	0.00	43.09	100%
Low Growth & High Prices	2030-2031	82.16	0.00	82.16	100%	43.23	0.00	43.23	100%
Low Growth & High Prices	2031-2032	82.67	0.00	82.67	100%	43.41	0.00	43.41	100%
Low Growth & High Prices	2032-2033	83.08	0.00	83.08	100%	43.52	0.00	43.52	100%
Low Growth & High Prices	2033-2034	83.56	0.00	83.56	100%	43.70	0.00	43.70	100%
Low Growth & High Prices	2034-2035	84.02	0.00	84.02	100%	43.91	0.00	43.91	100%
Low Growth & High Prices	2035-2036	84.55	0.00	84.55	100%	44.15	0.00	44.15	100%
Low Growth & High Prices	2036-2037	85.00	0.00	85.00	100%	44.32	0.00	44.32	100%
Low Growth & High Prices	2037-2038	85.43	0.00	85.43	100%	44.50	0.00	44.50	100%
Low Growth & High Prices	2038-2039	85.85	0.00	85.85	100%	44.68	0.00	44.68	100%
Low Growth & High Prices	2039-2040	86.29	0.00	86.29	100%	44.88	0.00	44.88	100%

APPENDIX 7.2: PEAK DAY DEMAND TABLE CARBON REDUCTION

Peak Day Demand - Served and Unserved (MDth/day) Before Resource Additions & Net of DSM Savings													
Scenario	Gas Year	La Grande				Klamath Falls				Medord/Roseburg			
		La Grande Served	La Grande Unserved	La Grande Total	% of Peak Day Served	Klamath Falls Served	Klamath Falls Unserved	Klamath Falls Total	% of Peak Day Served	Medord/Roseburg Served	Medord/Roseburg Unserved	Medord/Roseburg Total	% of Peak Day Served
Carbon Reduction	2019-2020	8.27	0.00	8.27	100%	14.74	0.00	14.74	100%	67.27	0.00	67.27	100%
Carbon Reduction	2020-2021	8.31	0.00	8.31	100%	14.87	0.00	14.87	100%	67.94	0.00	67.94	100%
Carbon Reduction	2021-2022	8.01	0.00	8.01	100%	14.28	0.00	14.28	100%	65.38	0.00	65.38	100%
Carbon Reduction	2022-2023	8.05	0.00	8.05	100%	14.42	0.00	14.42	100%	66.12	0.00	66.12	100%
Carbon Reduction	2023-2024	8.10	0.00	8.10	100%	14.54	0.00	14.54	100%	66.82	0.00	66.82	100%
Carbon Reduction	2024-2025	8.15	0.00	8.15	100%	14.65	0.00	14.65	100%	67.52	0.00	67.52	100%
Carbon Reduction	2025-2026	8.19	0.00	8.19	100%	14.76	0.00	14.76	100%	68.25	0.00	68.25	100%
Carbon Reduction	2026-2027	8.15	0.00	8.15	100%	14.71	0.00	14.71	100%	68.25	0.00	68.25	100%
Carbon Reduction	2027-2028	8.19	0.00	8.19	100%	14.79	0.00	14.79	100%	68.87	0.00	68.87	100%
Carbon Reduction	2028-2029	8.16	0.00	8.16	100%	14.76	0.00	14.76	100%	68.94	0.00	68.94	100%
Carbon Reduction	2029-2030	8.14	0.00	8.14	100%	14.72	0.00	14.72	100%	69.00	0.00	69.00	100%
Carbon Reduction	2030-2031	8.18	0.00	8.18	100%	14.79	0.00	14.79	100%	69.53	0.00	69.53	100%
Carbon Reduction	2031-2032	8.22	0.00	8.22	100%	14.86	0.00	14.86	100%	70.07	0.00	70.07	100%
Carbon Reduction	2032-2033	8.25	0.00	8.25	100%	14.95	0.00	14.95	100%	70.61	0.00	70.61	100%
Carbon Reduction	2033-2034	8.22	0.00	8.22	100%	14.89	0.00	14.89	100%	70.52	0.00	70.52	100%
Carbon Reduction	2034-2035	8.26	0.00	8.26	100%	14.97	0.00	14.97	100%	71.00	0.00	71.00	100%
Carbon Reduction	2035-2036	8.30	0.00	8.30	100%	15.04	0.00	15.04	100%	71.46	0.00	71.46	100%
Carbon Reduction	2036-2037	8.34	0.00	8.34	100%	15.12	0.00	15.12	100%	71.93	0.00	71.93	100%
Carbon Reduction	2037-2038	8.37	0.00	8.37	100%	15.20	0.00	15.20	100%	72.40	0.00	72.40	100%
Carbon Reduction	2038-2039	8.41	0.00	8.41	100%	15.28	0.00	15.28	100%	72.85	0.00	72.85	100%
Carbon Reduction	2039-2040	8.44	0.00	8.44	100%	15.36	0.00	15.36	100%	73.29	0.00	73.29	100%

Peak Day Demand - Served and Unserved (MDth/day) Before Resource Additions & Net of DSM Savings									
Scenario	Gas Year	WA				ID			
		WA Served	WA Unserved	WA Total	% of Peak Day Served	ID Served	ID Unserved	ID Total	% of Peak Day Served
Carbon Reduction	2019-2020	178.46	0.00	178.46	100%	95.47	0.00	95.47	100%
Carbon Reduction	2020-2021	180.05	0.00	180.05	100%	96.44	0.00	96.44	100%
Carbon Reduction	2021-2022	141.26	0.00	141.26	100%	97.31	0.00	97.31	100%
Carbon Reduction	2022-2023	141.49	0.00	141.49	100%	98.56	0.00	98.56	100%
Carbon Reduction	2023-2024	143.09	0.00	143.09	100%	100.06	0.00	100.06	100%
Carbon Reduction	2024-2025	144.58	0.00	144.58	100%	101.41	0.00	101.41	100%
Carbon Reduction	2025-2026	146.05	0.00	146.05	100%	101.59	0.00	101.59	100%
Carbon Reduction	2026-2027	147.47	0.00	147.47	100%	100.90	0.00	100.90	100%
Carbon Reduction	2027-2028	148.88	0.00	148.88	100%	101.86	0.00	101.86	100%
Carbon Reduction	2028-2029	150.26	0.00	150.26	100%	102.79	0.00	102.79	100%
Carbon Reduction	2029-2030	151.65	0.00	151.65	100%	103.73	0.00	103.73	100%
Carbon Reduction	2030-2031	152.90	0.00	152.90	100%	104.69	0.00	104.69	100%
Carbon Reduction	2031-2032	154.12	0.00	154.12	100%	105.69	0.00	105.69	100%
Carbon Reduction	2032-2033	155.32	0.00	155.32	100%	106.67	0.00	106.67	100%
Carbon Reduction	2033-2034	156.51	0.00	156.51	100%	106.84	0.00	106.84	100%
Carbon Reduction	2034-2035	157.65	0.00	157.65	100%	107.87	0.00	107.87	100%
Carbon Reduction	2035-2036	158.82	0.00	158.82	100%	108.93	0.00	108.93	100%
Carbon Reduction	2036-2037	159.94	0.00	159.94	100%	109.97	0.00	109.97	100%
Carbon Reduction	2037-2038	161.04	0.00	161.04	100%	111.04	0.00	111.04	100%
Carbon Reduction	2038-2039	162.13	0.00	162.13	100%	112.11	0.00	112.11	100%
Carbon Reduction	2039-2040	163.20	0.00	163.20	100%	113.19	0.00	113.19	100%

APPENDIX 7.2: PEAK DAY DEMAND TABLE AVERAGE CASE

Peak Day Demand - Served and Unserved (MDth/day) Before Resource Additions & Net of DSM Savings													
Scenario	Gas Year	La Grande				Klamath Falls				Medord/Roseburg			
		Served	Unserved	Total	% of Peak Day Served	Served	Unserved	Total	% of Peak Day Served	Served	Unserved	Total	% of Peak Day Served
Average Case	2019-2020	3.60	0.00	3.60	100%	6.92	0.00	6.92	100%	32.83	0.00	32.83	100%
Average Case	2020-2021	3.61	0.00	3.61	100%	6.98	0.00	6.98	100%	33.16	0.00	33.16	100%
Average Case	2021-2022	3.43	0.00	3.43	100%	6.52	0.00	6.52	100%	31.15	0.00	31.15	100%
Average Case	2022-2023	3.45	0.00	3.45	100%	6.58	0.00	6.58	100%	31.51	0.00	31.51	100%
Average Case	2023-2024	3.47	0.00	3.47	100%	6.64	0.00	6.64	100%	31.87	0.00	31.87	100%
Average Case	2024-2025	3.49	0.00	3.49	100%	6.69	0.00	6.69	100%	32.19	0.00	32.19	100%
Average Case	2025-2026	3.48	0.00	3.48	100%	6.68	0.00	6.68	100%	32.31	0.00	32.31	100%
Average Case	2026-2027	3.46	0.00	3.46	100%	6.66	0.00	6.66	100%	32.30	0.00	32.30	100%
Average Case	2027-2028	3.48	0.00	3.48	100%	6.69	0.00	6.69	100%	32.58	0.00	32.58	100%
Average Case	2028-2029	3.49	0.00	3.49	100%	6.72	0.00	6.72	100%	32.83	0.00	32.83	100%
Average Case	2029-2030	3.51	0.00	3.51	100%	6.76	0.00	6.76	100%	33.11	0.00	33.11	100%
Average Case	2030-2031	3.52	0.00	3.52	100%	6.78	0.00	6.78	100%	33.35	0.00	33.35	100%
Average Case	2031-2032	3.54	0.00	3.54	100%	6.82	0.00	6.82	100%	33.60	0.00	33.60	100%
Average Case	2032-2033	3.56	0.00	3.56	100%	6.85	0.00	6.85	100%	33.85	0.00	33.85	100%
Average Case	2033-2034	3.57	0.00	3.57	100%	6.89	0.00	6.89	100%	34.11	0.00	34.11	100%
Average Case	2034-2035	3.59	0.00	3.59	100%	6.92	0.00	6.92	100%	34.32	0.00	34.32	100%
Average Case	2035-2036	3.60	0.00	3.60	100%	6.95	0.00	6.95	100%	34.55	0.00	34.55	100%
Average Case	2036-2037	3.62	0.00	3.62	100%	6.99	0.00	6.99	100%	34.78	0.00	34.78	100%
Average Case	2037-2038	3.63	0.00	3.63	100%	7.02	0.00	7.02	100%	35.00	0.00	35.00	100%
Average Case	2038-2039	3.65	0.00	3.65	100%	7.06	0.00	7.06	100%	35.22	0.00	35.22	100%
Average Case	2039-2040	3.67	0.00	3.67	100%	7.10	0.00	7.10	100%	35.43	0.00	35.43	100%

Peak Day Demand - Served and Unserved (MDth/day) Before Resource Additions & Net of DSM Savings									
Scenario	Gas Year	WA	WA	WA	WA	ID	ID	ID	ID
		Served	Unserved	Total	% of Peak Day Served	Served	Unserved	Total	% of Peak Day Served
Average Case	2019-2020	81.97	0.00	81.97	100%	44.12	0.00	44.12	100%
Average Case	2020-2021	82.40	0.00	82.40	100%	44.44	0.00	44.44	100%
Average Case	2021-2022	64.09	0.00	64.09	100%	43.52	0.00	43.52	100%
Average Case	2022-2023	64.13	0.00	64.13	100%	44.03	0.00	44.03	100%
Average Case	2023-2024	64.88	0.00	64.88	100%	44.70	0.00	44.70	100%
Average Case	2024-2025	65.48	0.00	65.48	100%	45.26	0.00	45.26	100%
Average Case	2025-2026	66.07	0.00	66.07	100%	45.26	0.00	45.26	100%
Average Case	2026-2027	66.61	0.00	66.61	100%	44.99	0.00	44.99	100%
Average Case	2027-2028	67.17	0.00	67.17	100%	45.37	0.00	45.37	100%
Average Case	2028-2029	67.71	0.00	67.71	100%	45.74	0.00	45.74	100%
Average Case	2029-2030	68.28	0.00	68.28	100%	46.12	0.00	46.12	100%
Average Case	2030-2031	68.81	0.00	68.81	100%	46.52	0.00	46.52	100%
Average Case	2031-2032	69.35	0.00	69.35	100%	46.95	0.00	46.95	100%
Average Case	2032-2033	69.85	0.00	69.85	100%	47.34	0.00	47.34	100%
Average Case	2033-2034	70.40	0.00	70.40	100%	47.79	0.00	47.79	100%
Average Case	2034-2035	70.93	0.00	70.93	100%	48.26	0.00	48.26	100%
Average Case	2035-2036	71.50	0.00	71.50	100%	48.74	0.00	48.74	100%
Average Case	2036-2037	72.00	0.00	72.00	100%	49.19	0.00	49.19	100%
Average Case	2037-2038	72.50	0.00	72.50	100%	49.65	0.00	49.65	100%
Average Case	2038-2039	73.00	0.00	73.00	100%	50.12	0.00	50.12	100%
Average Case	2039-2040	73.51	0.00	73.51	100%	50.61	0.00	50.61	100%

APPENDIX 7.2: PEAK DAY DEMAND TABLE EXPECTED CASE

Peak Day Demand - Served and Unserved (MDth/day) Before Resource Additions & Net of DSM Savings													
Scenario	Gas Year	La Grande				Klamath Falls				Medord/Roseburg			
		La Grande Served	La Grande Unserved	La Grande Total	% of Peak Day Served	Klamath Falls Served	Klamath Falls Unserved	Klamath Falls Total	% of Peak Day Served	Medord/Roseburg Served	Medord/Roseburg Unserved	Medord/Roseburg Total	% of Peak Day Served
Expected Case	2019-2020	8.27	0.00	8.27	100%	14.74	0.00	14.74	100%	67.27	0.00	67.27	100%
Expected Case	2020-2021	8.31	0.00	8.31	100%	14.87	0.00	14.87	100%	67.94	0.00	67.94	100%
Expected Case	2021-2022	7.78	0.00	7.78	100%	13.85	0.00	13.85	100%	63.46	0.00	63.46	100%
Expected Case	2022-2023	7.82	0.00	7.82	100%	13.98	0.00	13.98	100%	64.18	0.00	64.18	100%
Expected Case	2023-2024	7.87	0.00	7.87	100%	14.10	0.00	14.10	100%	64.86	0.00	64.86	100%
Expected Case	2024-2025	7.91	0.00	7.91	100%	14.21	0.00	14.21	100%	65.54	0.00	65.54	100%
Expected Case	2025-2026	7.89	0.00	7.89	100%	14.19	0.00	14.19	100%	65.70	0.00	65.70	100%
Expected Case	2026-2027	7.84	0.00	7.84	100%	14.12	0.00	14.12	100%	65.61	0.00	65.61	100%
Expected Case	2027-2028	7.87	0.00	7.87	100%	14.20	0.00	14.20	100%	66.20	0.00	66.20	100%
Expected Case	2028-2029	7.91	0.00	7.91	100%	14.27	0.00	14.27	100%	66.76	0.00	66.76	100%
Expected Case	2029-2030	7.95	0.00	7.95	100%	14.35	0.00	14.35	100%	67.34	0.00	67.34	100%
Expected Case	2030-2031	7.99	0.00	7.99	100%	14.42	0.00	14.42	100%	67.87	0.00	67.87	100%
Expected Case	2031-2032	8.02	0.00	8.02	100%	14.50	0.00	14.50	100%	68.39	0.00	68.39	100%
Expected Case	2032-2033	8.06	0.00	8.06	100%	14.57	0.00	14.57	100%	68.90	0.00	68.90	100%
Expected Case	2033-2034	8.10	0.00	8.10	100%	14.65	0.00	14.65	100%	69.41	0.00	69.41	100%
Expected Case	2034-2035	8.14	0.00	8.14	100%	14.72	0.00	14.72	100%	69.87	0.00	69.87	100%
Expected Case	2035-2036	8.17	0.00	8.17	100%	14.80	0.00	14.80	100%	70.33	0.00	70.33	100%
Expected Case	2036-2037	8.21	0.00	8.21	100%	14.87	0.00	14.87	100%	70.79	0.00	70.79	100%
Expected Case	2037-2038	8.24	0.00	8.24	100%	14.95	0.00	14.95	100%	71.25	0.00	71.25	100%
Expected Case	2038-2039	8.28	0.00	8.28	100%	15.03	0.00	15.03	100%	71.69	0.00	71.69	100%
Expected Case	2039-2040	8.32	0.00	8.32	100%	15.11	0.00	15.11	100%	72.12	0.00	72.12	100%

Peak Day Demand - Served and Unserved (MDth/day) Before Resource Additions & Net of DSM Savings									
Scenario	Gas Year	WA				ID			
		WA Served	WA Unserved	WA Total	% of Peak Day Served	ID Served	ID Unserved	ID Total	% of Peak Day Served
Expected Case	2019-2020	178.46	0.00	178.46	100%	95.47	0.00	95.47	100%
Expected Case	2020-2021	179.82	0.00	179.82	100%	96.37	0.00	96.37	100%
Expected Case	2021-2022	135.76	0.00	135.76	100%	94.17	0.00	94.17	100%
Expected Case	2022-2023	135.83	0.00	135.83	100%	95.36	0.00	95.36	100%
Expected Case	2023-2024	137.38	0.00	137.38	100%	96.79	0.00	96.79	100%
Expected Case	2024-2025	138.75	0.00	138.75	100%	98.06	0.00	98.06	100%
Expected Case	2025-2026	140.11	0.00	140.11	100%	98.04	0.00	98.04	100%
Expected Case	2026-2027	141.39	0.00	141.39	100%	97.40	0.00	97.40	100%
Expected Case	2027-2028	142.67	0.00	142.67	100%	98.30	0.00	98.30	100%
Expected Case	2028-2029	143.93	0.00	143.93	100%	99.16	0.00	99.16	100%
Expected Case	2029-2030	145.21	0.00	145.21	100%	100.03	0.00	100.03	100%
Expected Case	2030-2031	146.38	0.00	146.38	100%	100.94	0.00	100.94	100%
Expected Case	2031-2032	147.55	0.00	147.55	100%	101.90	0.00	101.90	100%
Expected Case	2032-2033	148.67	0.00	148.67	100%	102.82	0.00	102.82	100%
Expected Case	2033-2034	149.83	0.00	149.83	100%	103.80	0.00	103.80	100%
Expected Case	2034-2035	150.95	0.00	150.95	100%	104.81	0.00	104.81	100%
Expected Case	2035-2036	152.10	0.00	152.10	100%	105.85	0.00	105.85	100%
Expected Case	2036-2037	153.18	0.00	153.18	100%	106.86	0.00	106.86	100%
Expected Case	2037-2038	154.24	0.00	154.24	100%	107.88	0.00	107.88	100%
Expected Case	2038-2039	155.29	0.00	155.29	100%	108.93	0.00	108.93	100%
Expected Case	2039-2040	156.35	0.00	156.35	100%	109.99	0.00	109.99	100%

APPENDIX 7.2: ALTERNATE SUPPLY RESOURCES

Fossil Fuel Resources Modeled

Additional Resource	Size	Cost/Rates	Availability	Notes
Unsubscribed GTN Capacity	Up to 50,000 Dth	GTN Rate	2021	Currently available unsubscribed capacity from Kingsgate to Spokane
Medford Lateral Exp	50,000 Dth / Day	\$35M capital + GTN Rate	2022	Additional compression to facilitate more gas to flow from mainline GTN to Medford
Plymouth LNG	241,700 Dth w/70,500 Dth deliverability	NWP Rate	2021	Provides for peaking services and alleviates the need for costly pipeline expansions Pair with excess pipeline MDDO's to create firm transport

Renewable Resources Modeled

Resource	Dth per day	Dth per year	Levelized Cost Per Dth (Year 1)
Distributed Renewable Hydrogen Production - WA	166	60,509	\$53.48
Distributed Renewable Hydrogen Production - OR	166	60,509	\$50.00
Distributed LFG to RNG Production - WA	635	231,790	\$13.53
Centralized LFG to RNG Production - WA	1,814	662,256	\$11.73
Dairy Manure to RNG Production - WA	635	231,790	\$40.70
Wastewater Sludge to RNG Production - WA	513	187,245	\$18.95
Food Waste to RNG Production - WA	298	108,799	\$40.68
Distributed LFG to RNG Production - OR	635	231,790	\$13.53
Centralized LFG to RNG Production - OR	1,814	662,256	\$11.73
Dairy Manure to RNG Production - OR	635	231,790	\$40.23
Wastewater Sludge to RNG Production - OR	513	187,245	\$18.75
Food Waste to RNG Production - OR	298	108,799	\$40.21

Resources Not Modeled

Future Supply Resources	Size	Cost/Rates	Availability	Notes
Co. Owned LNG	600,000 Dth w/ 150,000 of deliverability	\$75 Million plus \$2 Million annual O&M	2024	On site, in service territory liquefaction and vaporization facility
Various pipelines – Pacific Connector, Cross-Cascades, etc.	Varies	Precedent Agreement Rates	2022	Requires additional mainline capacity on NWPL or GTN to get to service territory
Large Scale LNG	Varies	Commodity less Fuel	2024	Speculative, needs pipeline transport
In Ground Storage	Varies	Varies	Varies	Requires additional mainline transport to get to service territory
Satellite LNG	Varies	\$13M capital cost plus 665k O&M	2022	provides for peaking services and alleviates the need for costly pipeline expansions. \$3,000 per m3 with O&M assumed at 5.4%.

APPENDIX 8.1: DISTRIBUTION SYSTEM MODELING

OVERVIEW

The primary goal of distribution system planning is to design for present needs and to plan for future expansion in order to serve demand growth. This allows Avista to satisfy current demand-serving requirements, while taking steps toward meeting future needs. Distribution system planning identifies potential problems and areas of the distribution system that require reinforcement. By knowing when and where pressure problems may occur, the necessary reinforcements can be incorporated into normal maintenance. Thus, more costly reactive and emergency solutions can be avoided.

COMPUTER MODELING

When designing new main extensions, computer modeling can help determine the optimum size facilities for present and future needs. Undersized facilities are costly to replace, and oversized facilities incur unnecessary expenses to Avista and its customers.

THEORY AND APPLICATION OF STUDY

Natural gas network load studies have evolved in the last decade to become a highly technical and useful means of analyzing the operation of a distribution system. Using a pipeline fluid flow formula, a specified parameter of each pipe element can be simultaneously solved. Through years of research, pipeline equations have been refined to the point where solutions obtained closely represent actual system behavior.

Avista conducts network load studies using GL Noble Denton's Synergi® 4.8.0 software. This computer-based modeling tool runs on a Windows operating system and allows users to analyze and interpret solutions graphically.

CREATING A MODEL

To properly study the distribution system, all natural gas main information is entered (length, pipe roughness and size) into the model. "Main" refers to all pipelines supplying services. Nodes are placed at all pipe intersections, beginnings and ends of mains, changes in pipe diameter/material, and to identify all large customers. A model element connects two nodes together. Therefore, a "to node" and a "from node" will represent an element between those two nodes. Almost all of the elements in a model are pipes.

Regulators are treated like adjustable valves in which the downstream pressure is set to a known value. Although specific regulator types can be entered for realistic behavior, the expected flow passing through the actual regulator is determined and the modeled regulator is forced to accommodate such flows.

FLUID MECHANICS OF THE MODEL

Pipe flow equations are used to determine the relationships between flow, pressure drop, diameter and pipe length. For all models, the Fundamental Flow equation (FM) is used due to its demonstrated reliability.

Efficiency factors are used to account for the equivalent resistance of valves, fittings and angle changes within the distribution system. Starting with a 95 percent factor, the efficiency can be changed to fine tune the model to match field results.

Pipe roughness, along with flow conditions, creates a friction factor for all pipes within a system. Thus, each pipe may have a unique friction factor, minimizing computational errors associated with generalized friction values.

LOAD DATA

All studies are considered steady state; all natural gas entering the distribution system must equal the natural gas exiting the distribution system at any given time.

Customer loads are obtained from Avista's customer billing system and converted to an algebraic format so loads can be generated for various conditions. Customer Management Module (CMM), an add-on application for Synergi, processes customer usage history and generates a base load (non-temperature dependent) and heat load (varying with temperature) for each customer.

In the event of a peak day or an extremely cold weather condition, it is assumed that all curtailable loads are interrupted. Therefore, the models will be conducted with only core loads.

DETERMINING NATURAL GAS CUSTOMERS' MAXIMUM HOURLY USAGE

DETERMINING DESIGN PEAK HOURLY LOAD

The design peak hourly load for a customer is estimated by adding the hourly base load and the hourly heat load for a design temperature. This estimate reflects highest system hourly demands, as shown in Table 1:

Table 1 - Determining Peak* Hourly Load			
Peak Hourly Base Load	+	Peak Hourly Heat Load	= Peak Hourly Load

This method differs from the approach that is used for IRP peak day load planning. The primary reason for this difference is due to the importance of responding to hourly peaking in the distribution system, while IRP resource planning focuses on peak day requirements to the city gate.

APPLYING LOADS

Having estimated the peak loads for all customers in a particular service area, the model can be loaded. The first step is to assign each load to the respective node or element.

GENERATING LOADS

Temperature-based and non-temperature-based loads are established for each node or element, thus loads can be varied based on any temperature (HDD). Such a tool is necessary to evaluate the difference in flow and pressure due to different weather conditions.

GEOGRAPHIC INFORMATION SYSTEM (GIS)

Several years ago Avista converted the natural gas facility maps to GIS. While the GIS can provide a variety of map products, the true power lies in the analytical capabilities. A GIS consists of three components: spatial operations, data association and map representation.

A GIS allows analysts to conduct spatial operations (relating a feature or facility to another geographically). A spatial operation is possible if a facility displayed on a map maintains a relationship to other facilities. Spatial relationships allow analysts to perform a multitude of queries, including:

- Identify electric customers adjacent to natural gas mains who are not currently using natural gas
- Display the number of customers assigned to particular pipes in Emergency Operating Procedure zones (geographical areas defined to aid in the safe isolation in the event of an emergency)
- Classify high-pressure pipeline proximity criteria

The second component of the GIS is data association. This allows analysts to model relationships between facilities displayed on a map to tabular information in a database. Databases store facility information, such as pipe size, pipe material, pressure rating, or related information (e.g., customer databases, equipment databases and work management systems). Data association allows interactive queries within a map-like environment.

Finally, the GIS provides a means to create maps of existing facilities in different scales, projections and displays. In addition, the results of a comparative or spatial analysis can be presented pictorially. This allows users to present complex analyses rapidly and in an easy-to-understand method.

BUILDING SYNERGI® MODELS FROM A GIS

The GIS can provide additional benefits through the ease of creation and maintenance of load studies. Avista can create load studies from the GIS based on tabular data (attributes) installed during the mapping process.

MAINTENANCE USING A GIS

The GIS helps maintain the existing distribution facility by allowing a design to be initiated on a GIS. Currently, design jobs for the company's natural gas system are managed through Avista's Maximo tool. Once jobs are completed, the as-built information is automatically updated on GIS, eliminating the need to convert physical maps to a GIS at a later date. Because the facility is updated, load studies can remain current by refreshing the analysis.

DEVELOPING A PRESENT CASE LOAD STUDY

In order for any model to have accuracy, a present case model has to be developed that reflects what the system was doing when downstream pressures and flows are known. To establish the present case, pressure recording instruments located throughout the distribution system are used.

These field instruments record pressure and temperature throughout the winter season. Various locations recording simultaneously are used to validate the model. Customer loads on Synergi® are generated to correspond with actual temperatures recorded on the instruments. An accurate model's downstream pressures will match the corresponding field instrument's pressures. Efficiency factors are adjusted to further refine the model's pressures and better match the actual conditions.

Since telemetry at the gate stations record hourly flow, temperature and pressure, these values are used to validate the model. All loads are representative of the average daily temperature and are defined as hourly flows. If the load generating method is truly accurate, all natural gas entering the actual system (physical) equals total natural gas demand solved by the simulated system (model).

DEVELOPING A PEAK CASE LOAD STUDY

Using the calculated peak loads, a model can be analyzed to identify the behavior during a peak day. The efficiency factors established in the present case are used throughout subsequent models.

ANALYZING RESULTS

After a model has been balanced, several features within the Synergi® model are used to interpret results. Color plots are generated to depict flow direction, pressure, and pipe diameter with specific break points. Reinforcements can be identified by visual inspection. When user edits are completed and the model is re-balanced, pressure changes can be visually displayed, helping identify optimum reinforcements.

PLANNING CRITERIA

In most instances, models resulting in node pressures below 15 psig indicate a likelihood of distribution low pressure, and therefore necessitate reinforcements. For most Avista distribution systems, a minimum of 15 psig will ensure deliverability as natural gas exits the distribution mains and travels through service pipelines to a customer's meter. Some Avista distribution areas operate at lower pressures and are assigned a minimum pressure of 5 psig for model results. Given a lower operating pressure, service pipelines in such areas are sized accordingly to maintain reliability.

DETERMINING MAXIMUM CAPACITY FOR A SYSTEM

Using a peak day model, loads can be prorated at intervals until area pressures drop to 15 psig. At that point, the total amount of natural gas entering the system equals the maximum capacity before new construction is necessary. The difference between natural gas entering the system in this scenario and a peak day model is the maximum additional capacity that can be added to the system.

Since the approximate natural gas usage for the average customer is known, it can be determined how many new customers can be added to the distribution system before necessitating system reinforcements. The above models and procedures are utilized with new construction proposals or pipe reinforcements to determine the potential increase in capacity.

FIVE-YEAR FORECASTING

The intent of the load study forecasting is to predict the system's behavior and reinforcements necessary within the next five years. Various Avista personnel provide information to determine where and why certain areas may experience growth.

By combining information from Avista's demand forecast, IRP planning efforts, regional growth plans and area developments, proposals for pipeline reinforcements and expansions are evaluated with Synergi®.

Appendix 8.2

Oregon Public Utility Commission Order No. 16-109 (the Order) included the following language:

Finally, as part of the IRP-vetting process and subsequent rate proceedings, we expect that Avista conduct and present comprehensive analyses of its system upgrades. Such analyses should provide: (1) a comprehensive cost-benefit analysis of whether and when the investment should be built; (2) evaluation of a range of alternative build dates and the impact on reliability and customer rates; (3) credible evidence on the likelihood of disruptions based on historical experience; (4) evidence on the range of possible reliability incidents; (5) evidence about projected loads and customers in the area; and (6) adequate consideration of alternatives, including the use of interruptibility or increased demand-side measures to improve reliability and system resiliency.

In order to address this portion of the Order, Avista has prepared this appendix, which includes documentation addressing the six points above for each of the natural gas distribution system enhancements included in the 2021 Natural Gas Integrated Resource Plan (IRP) for Avista's Oregon service territory. Each of these three enhancement projects represents a significant, discrete project which is out of the ordinary course of business (that is to say, different from ongoing capital investment to address Federal or State regulatory requirements, relocation of pipe or facilities as requested by others, failed pipe or facilities, etc., all of which occur routinely over time and which are discussed below).

The routine, ongoing capital investments can be loosely classified in the following categories (which are not mutually exclusive):

- Safety – Ongoing safety related capital investment includes the repair or replacement of obsolete or failed pipe and facilities. This category includes, but is not necessarily limited to, investment to address deteriorated or isolated steel pipe, cathodic protection, and the replacement of pipeline which has been built over, as well as the remedy of shallow pipe or the repair or replacement of leaking pipe.
- System Maintenance – Ongoing capital investment related to system maintenance includes replacement of facilities or pipe that has reached the end of their useful lives, as well as other general investment required to maintain Avista's ability to reliably serve customers.
- Relocation Requested by Others – Ongoing capital investment related to relocation requested by others falls primarily into two categories, relocation requested by other parties which is required under the terms of our franchise agreements (such as

relocations required to accommodate road or highway construction or relocation), or relocation requested by customers or others (in which case the customer would be responsible for the cost of the immediate request, but in which case Avista may perform additional work, such as the replacement of a steel service with polyethylene to reduce future maintenance or cathodic protection requirements on that pipe).

- Mandated System Investment – Ongoing capital investment in this category is driven by Federal or State regulatory requirements, such as investment that results from TIMP/DIMP programs, among other programs.

Avista's Aldyl-A replacement program has been addressed in substantial detail in Oregon Public Utility Commission Docket UG-246, Avista/500-501.



2020 Avista Natural Gas IRP

Technical Advisory Committee Meeting
June 17, 2020

2020 Natural Gas IRP schedule

- TAC 1: Wednesday, June 17, 2020:** TAC meeting expectations, 2020 IRP process and schedule, actions from 2018 IRP, and a Winter of 2018-2019 review. Procurement Plan and Resource Optimization benefits, Demand, Weather Analysis and a Weather Planning Standard, and an energy efficiency update.
- TAC 2: Thursday, August 6, 2020:** Market Analysis, Price Forecasts, Cost Of Carbon, demand forecasts and CPA results from AEG, Environmental Policies, fugitive emissions
- TAC 3: Wednesday, September 30, 2020:** Distribution, Avista's current supply-side resources overview, supply side resource options, renewable resources, overview of the major interstate pipelines and projects, and sensitivities and portfolio selection modeling.
- TAC 4: Wednesday, November 18, 2020:** Review assumptions and action items, final modeling results, portfolio risk analysis and 2020 Action Plan.
- TAC 5: February 2021:** TAC final review meeting (if necessary)

Agenda

- TAC meeting expectations
- 2020 IRP process and schedule
- Actions from 2018 IRP
- Winter of 2018-2019 review
- Demand
- Demand Forecast Methodology
- Weather Analysis
- Weather Planning Standard
- Procurement Plan
- Resource Optimization benefits
- Energy efficiency update

Avista's IRP Process

- Comprehensive analysis bringing demand forecasting and existing and potential supply-side and demand-side resources together into a 20-year, risk adjusted least-cost plan
- Considers:
 - Customer growth and usage
 - Weather planning standard
 - Demand-side management opportunities
 - Existing and potential supply-side resource options
 - Risk
 - Public participation through Technical Advisory Committee meetings (TAC)
 - Distribution upgrades
- 2018 IRP filed in all three jurisdictions on August 31, 2018 and acknowledged

The Natural Gas System

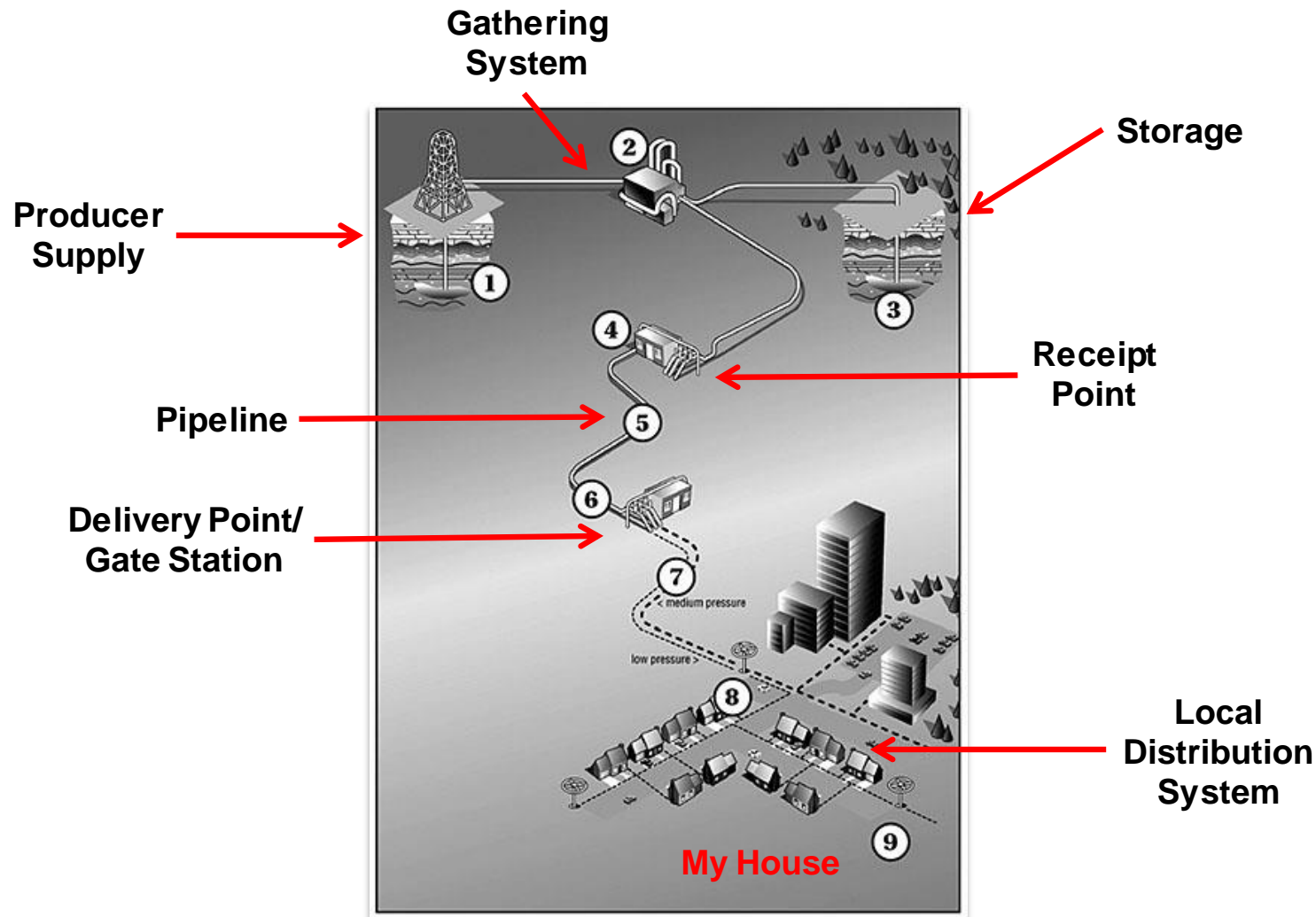

2018 Avista Natural Gas IRP – Action Plan

1. Avista's 2020 IRP will contain an individual measure level for dynamic DSM program structure in its analytics. In prior IRP's, it was a deterministic method based on based on Expected Case assumptions. In the 2020 IRP, each portfolio will have the ability to select conservation to meet unserved customer demand. Avista will explore methods to enable a dynamic analytical process for the evaluation of conservation potential within individual portfolios.
2. Work with Staff to get clarification on types of natural gas distribution system analyses for possible inclusion in the 2020 IRP.
3. Work with Staff to clarify types of distribution system costs for possible inclusion in our avoided cost calculation.
4. Revisit coldest on record planning standard and discuss with TAC for prudence.
5. Provide additional information on resource optimization benefits and analyze risk exposure.
6. DSM—Integration of ETO and AEG/CPA data. Discuss the integration of ETO and AEG/CPA data as well as past program(s) experience, knowledge of current and developing markets, and future codes and standards.
7. Carbon Costs – consult Washington State Commission's Acknowledgement Letter Attachment in its 2017 Electric IRP (Docket UE-161036), where emissions price modeling is discussed, including the cost of risk of future greenhouse gas regulation, in addition to known regulations.
8. Avista will ensure Energy Trust (ETO) has sufficient funding to acquire therm savings of the amount identified and approved by the Energy Trust Board.

2018 Avista Natural Gas IRP Action Plan

cont.

- 9. Regarding high pressure distribution or city gate station capital work, Avista does not expect any supply side or distribution resource additions to be needed in our Oregon territory for the next four years, based on current projections. However, should conditions warrant that capital work is needed on a high pressure distribution line or city gate station in order to deliver safe and reliable services to our customers, the Company is not precluded from doing such work. Examples of these necessary capital investments include the following:
 - • Natural gas infrastructure investment not included as discrete projects in IRP
 - – Consistent with the preceding update, these could include system investment to respond to mandates, safety needs, and/or maintenance of system associated with reliability
 - • Including, but not limited to Aldyl A replacement, capacity reinforcements, cathodic protection, isolated steel replacement, etc.
 - – Anticipated PHMSA guidance or rules related to 49 CFR Part § 192 that will likely requires additional capital to comply
 - • Officials from both PHMSA and the AGA have indicated it is not prudent for operators to wait for the federal rules to become final before improving their systems to address these expected rules.
 - – Construction of gas infrastructure associated with growth
 - – Other special contract projects not known at the time the IRP was published
 - • Other non-IRP investments common to all jurisdictions that are ongoing, for example:
 - – Enterprise technology projects & programs
 - – Corporate facilities capital maintenance and improvements
- An updated table 8.4 for those distribution projects in Oregon:
 - Location
 - Klamath Falls, OR
 - Sutherlin, OR
- 10. Avista will work with members of the OPUC to determine an alternative stochastic approach to Monte Carlo analysis prior to Avista's 2020 IRP and share any recommendations with the TAC members.



That Could Never Happen!

Gas Supply Winter 2018-2019

Enbridge Pipeline Rupture



Pipeline Rupture

AECO

Sumas

Pipeline ruptured October 9th

- 2.4 Bcf off the system
- Jackson Prairie Storage - down
- **NWP Roosevelt** compressor maintenance
- Within 24 hours, 50% of demand came off
- Moderate temperatures across Pacific NW
- Average gas prices < \$3/Dth
- Gas rebate deferral balances growing

Jackson Prairie Storage

NWP Roosevelt
Compressor

Rockies

Winter 2018-2019 Outlook

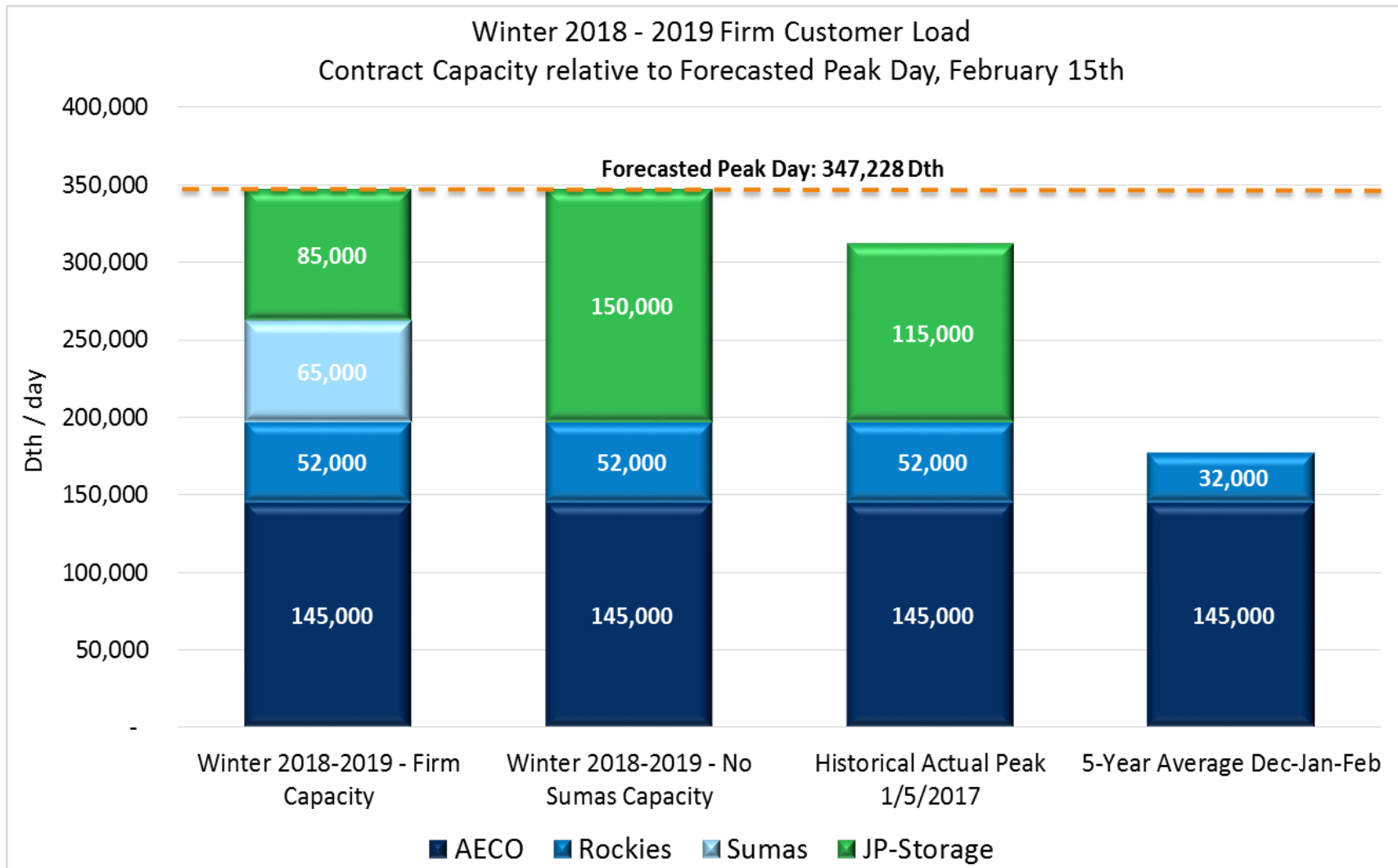

Historical Winter Firm Customer Load

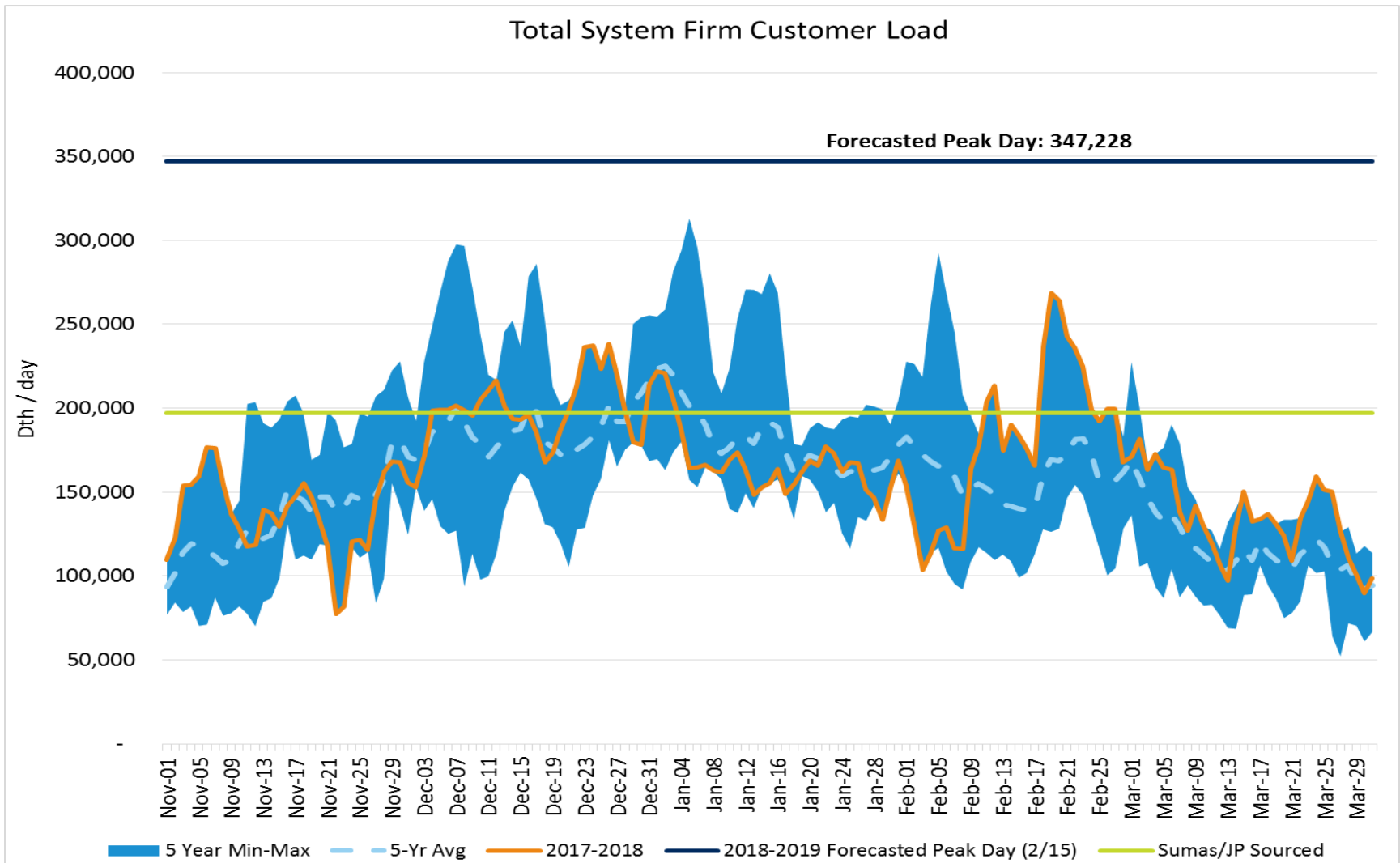

Winter '18 - '19 Blended Temps

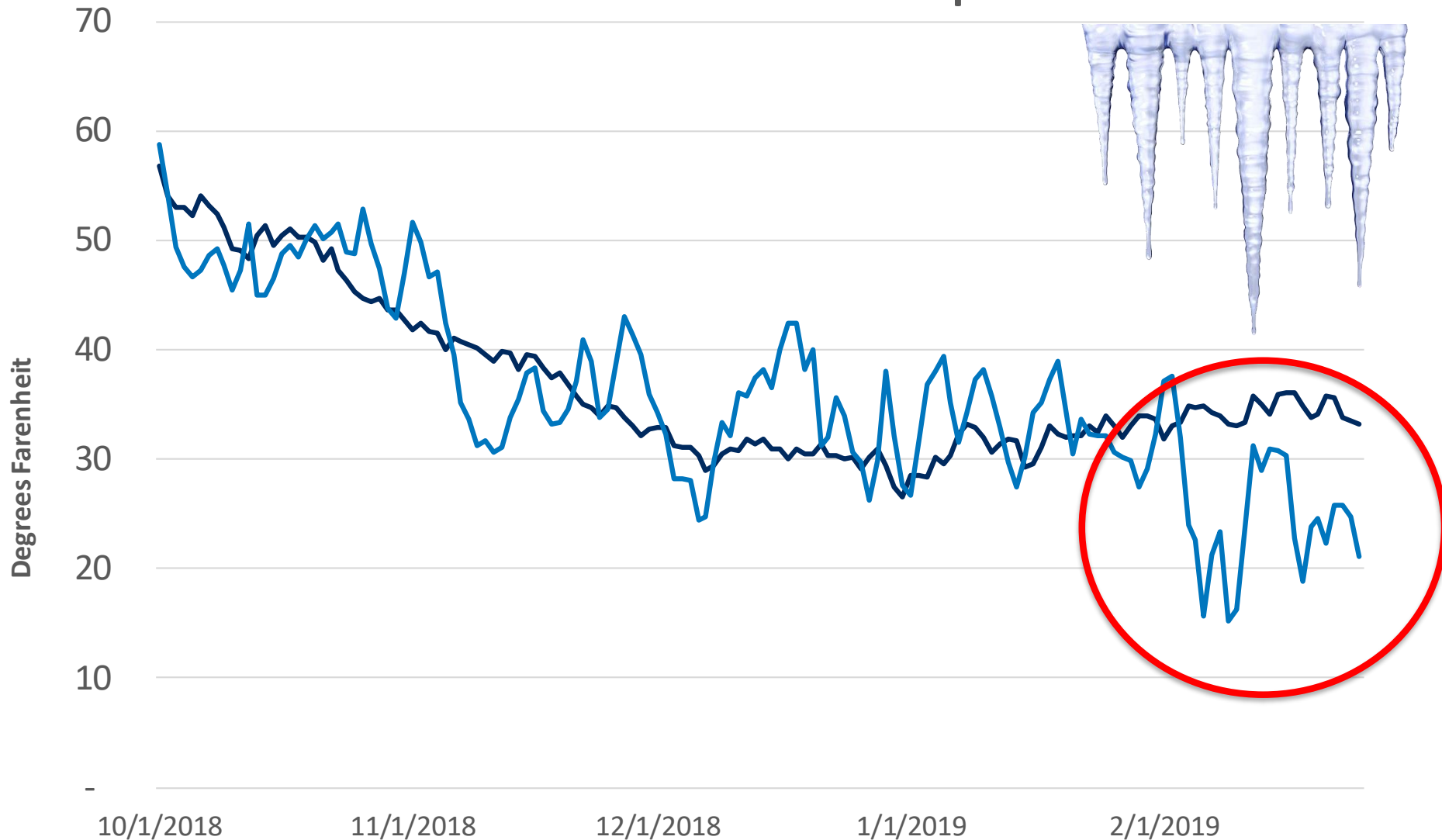

— 20 Yr Avg Historical - Blended

— Actual '18 - '19 - Blended

*Avg. weather

Operation Flow Order (OFO)

- **Northwest Pipeline (NWP) Operational Flow Order**

An OFO is declared to provide the needed displacement on NWP's system to meet firm commitments. When scheduled quantities exceed physical capacity, NWP is in a potential OFO situation. In other words,

****Avista must flow gas from west to east.****



US Storage

Working gas in underground storage, Lower 48 states

[Summary text](#) [CSV](#) [JSN](#)

Region	Stocks billion cubic feet (Bcf)				Historical Comparisons			
	03/08/19	03/01/19	net change	implied flow	Year ago (03/08/18)	% change	5-year average (2014-18)	% change
East	262	311	-49	-49	320	-18.1	338	-22.5
Midwest	287	338	-51	-51	354	-18.9	398	-27.9
Mountain	66	73	-7	-7	94	-29.8	116	-43.1
Pacific	102	112	-10	-10	170	-40.0	199	-48.7
South Central	469	557	-88	-88	607	-22.7	705	-33.5
Salt	129	180	-51	-51	186	-30.6	195	-33.8
Nonsalt	340	377	-37	-37	420	-19.0	510	-33.3
Total	1,186	1,390	-204	-204	1,545	-23.2	1,755	-32.4

Totals may not equal sum of components because of independent rounding.

569 Bcf below 5 yr avg

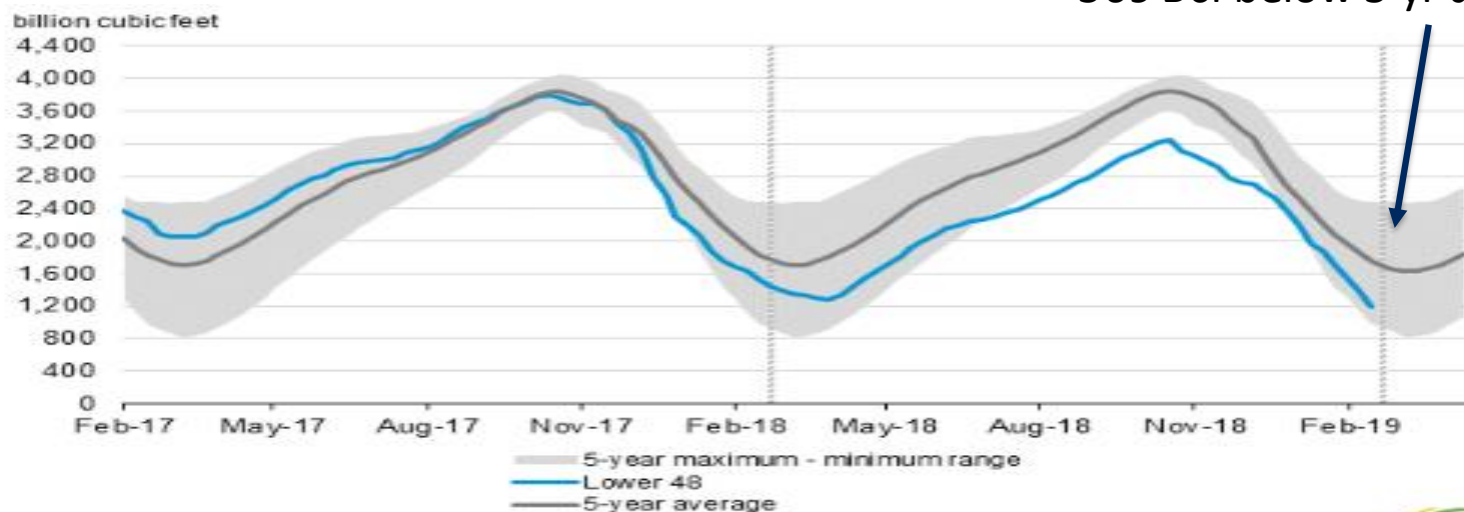

JP Storage Levels

Avista – 1.0 bcf
Puget – 2.2 bcf
Nwp – 3.5 bcf

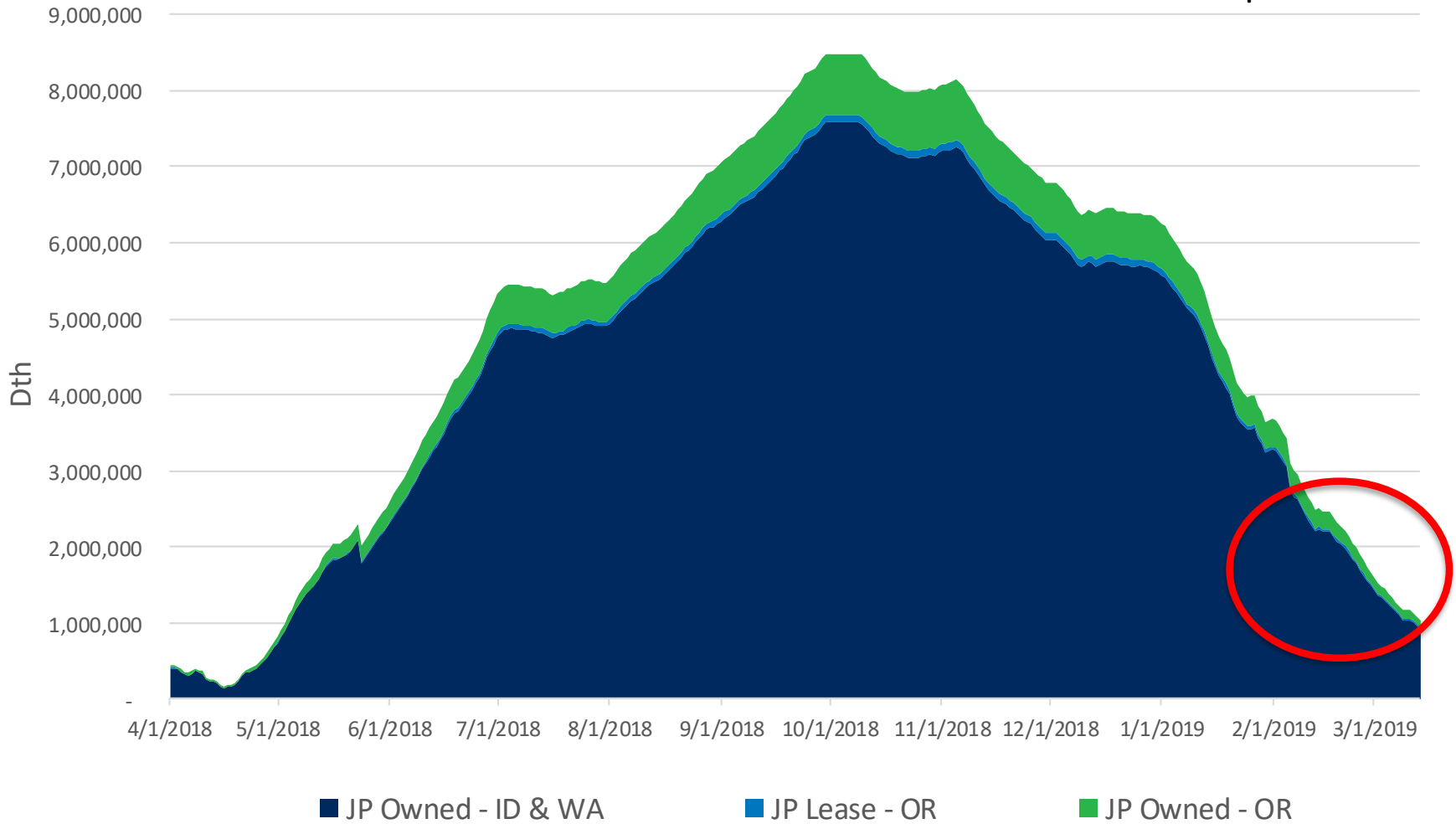

Jackson Prairie Compressor C-9

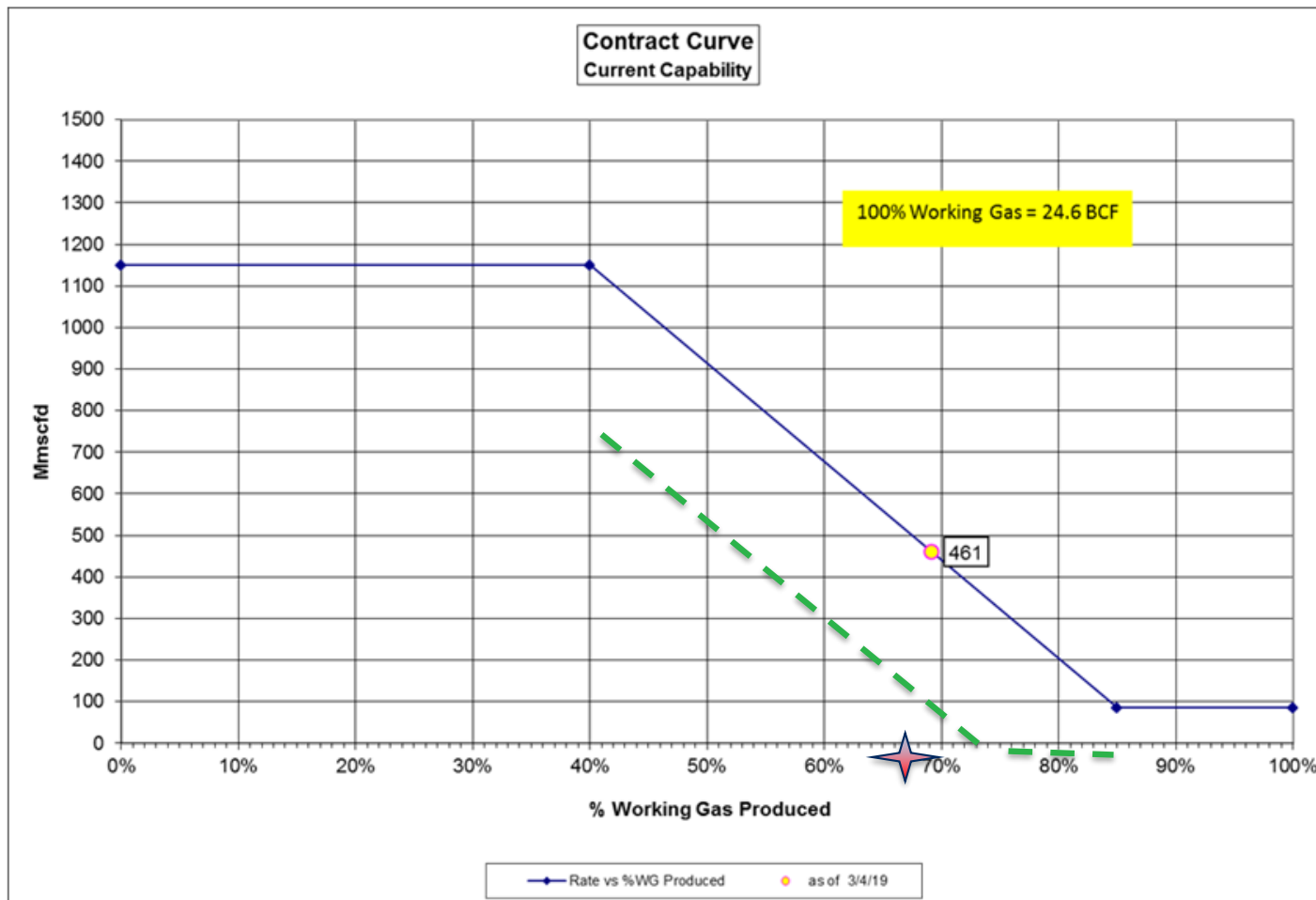

Compressor
Failed
2/10/19

Reduction of withdrawal capability by approx. 200-300 MMscfd
Avista withdrawal ability < 90 MMscfd (JP demand 50 – 90 MMscfd)

Enbridge Capacity Cuts

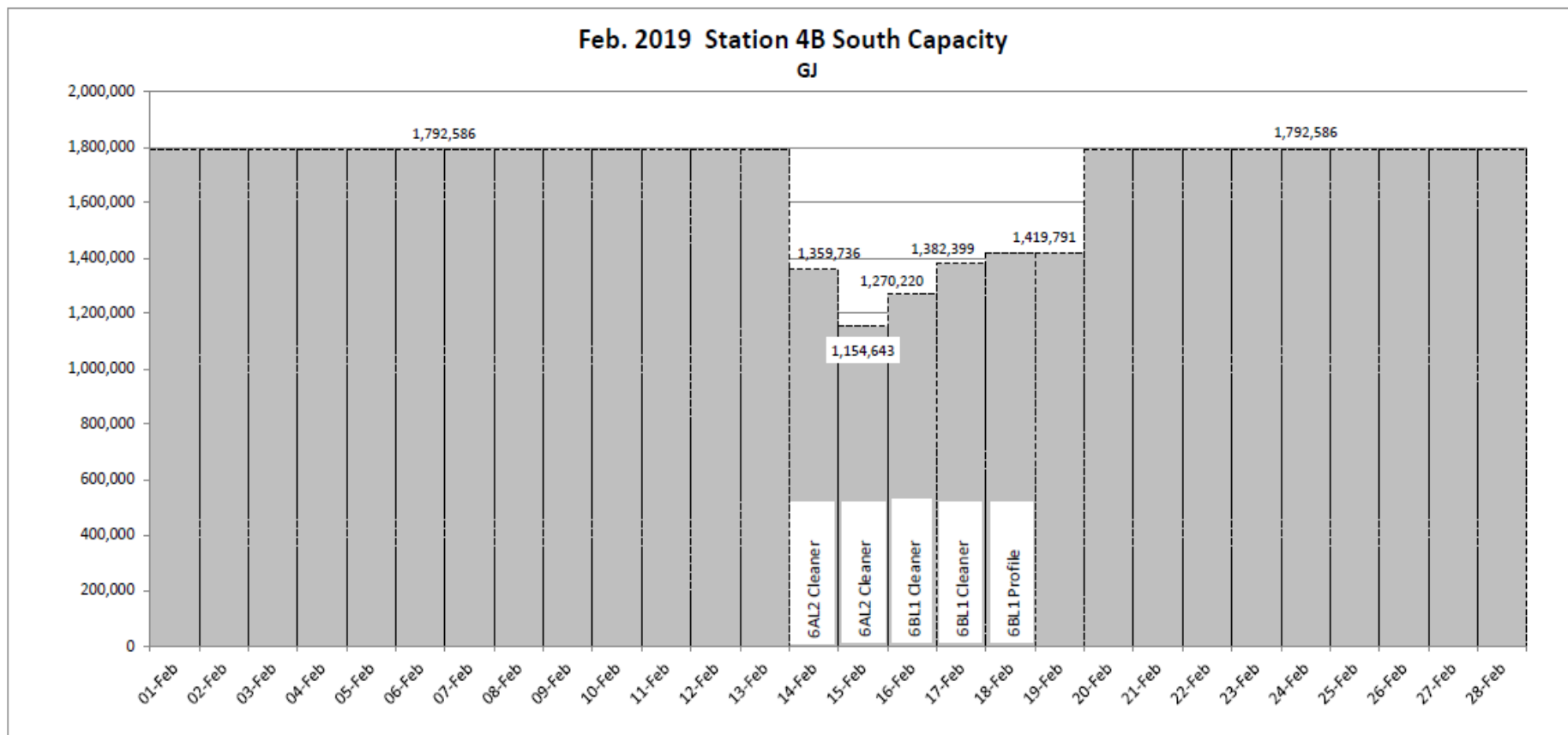

Pipeline Entitlements

- Entitlements are used to balance demand
 - Entitlement tolerances are tiered
 - 13%, 8%, 5%, 3% depending on severity of issue
 - Overrun entitlement
 - Total demand must not exceed nominations by the prescribed level
 - Example: Avista nominates 150,000 Dth on pipeline, demand must be AT MOST 169,500 Dth
 - Entitlement penalties
 - Greater of \$10.00/ dth or 4x the highest midpoint price in region

Historical and Current Winter Loads

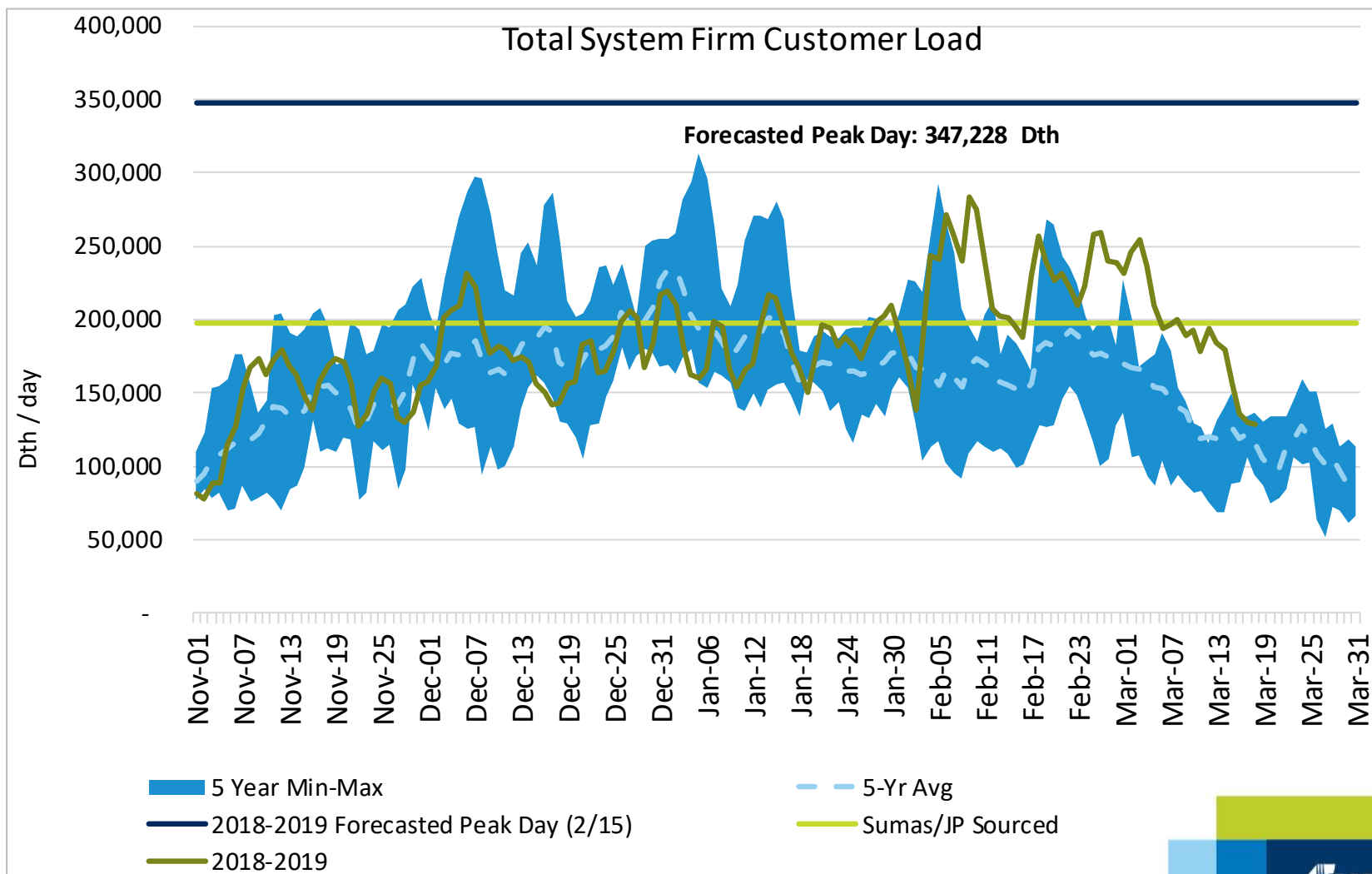

Planning Outcomes changes

- In order to reduce the risk around not being able to serve load on a peak day with late winter weather Avista is moving it's peak day from 2/15 to 2/28 for the WA/ID and La Grande



Avista's Demand Overview

Tom Pardee
Manager of Natural Gas Planning

Service Territory and Customer Overview

- Serves electric and natural gas customers in eastern Washington and northern Idaho, and natural gas customers in southern and eastern Oregon
 - Population of service area 1.5 million
 - ▶ 385,000 electric customers
 - ▶ 360,000 natural gas customers
- Has one of the smallest carbon footprints among America's 100 largest investor-owned utilities
- Committed to environmental stewardship and efficient use of resources

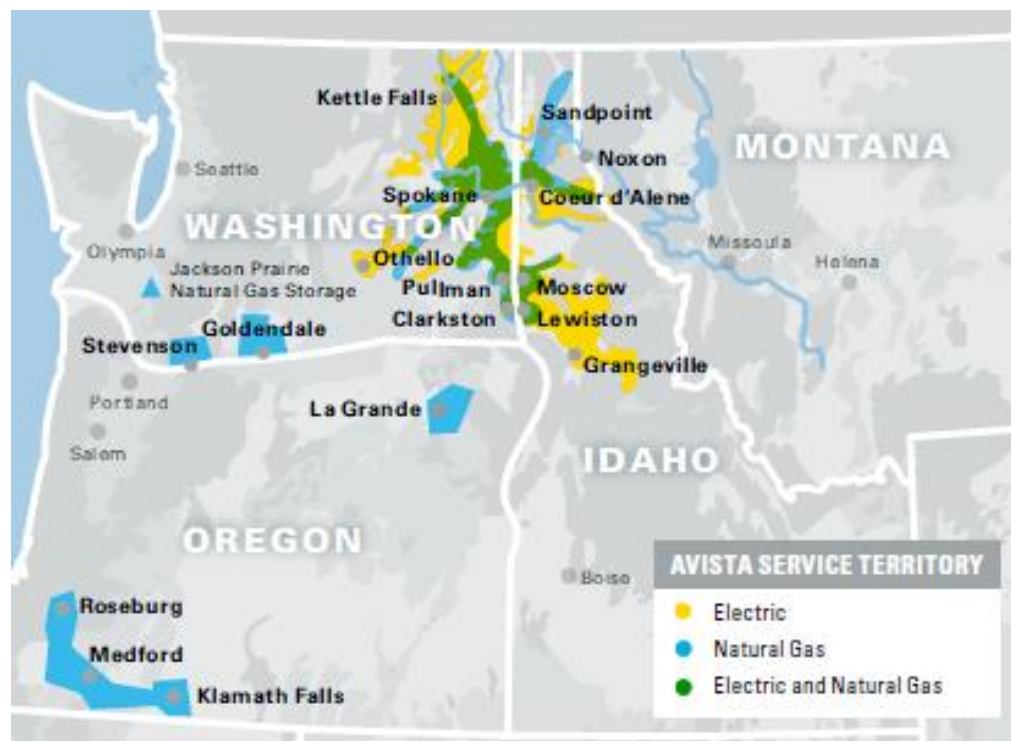

State	Total Customers	% of Total
Washington	170,000	47%
Oregon	103,000	29%
Idaho	87,000	24%
Total	360,000	100%

Klamath Falls

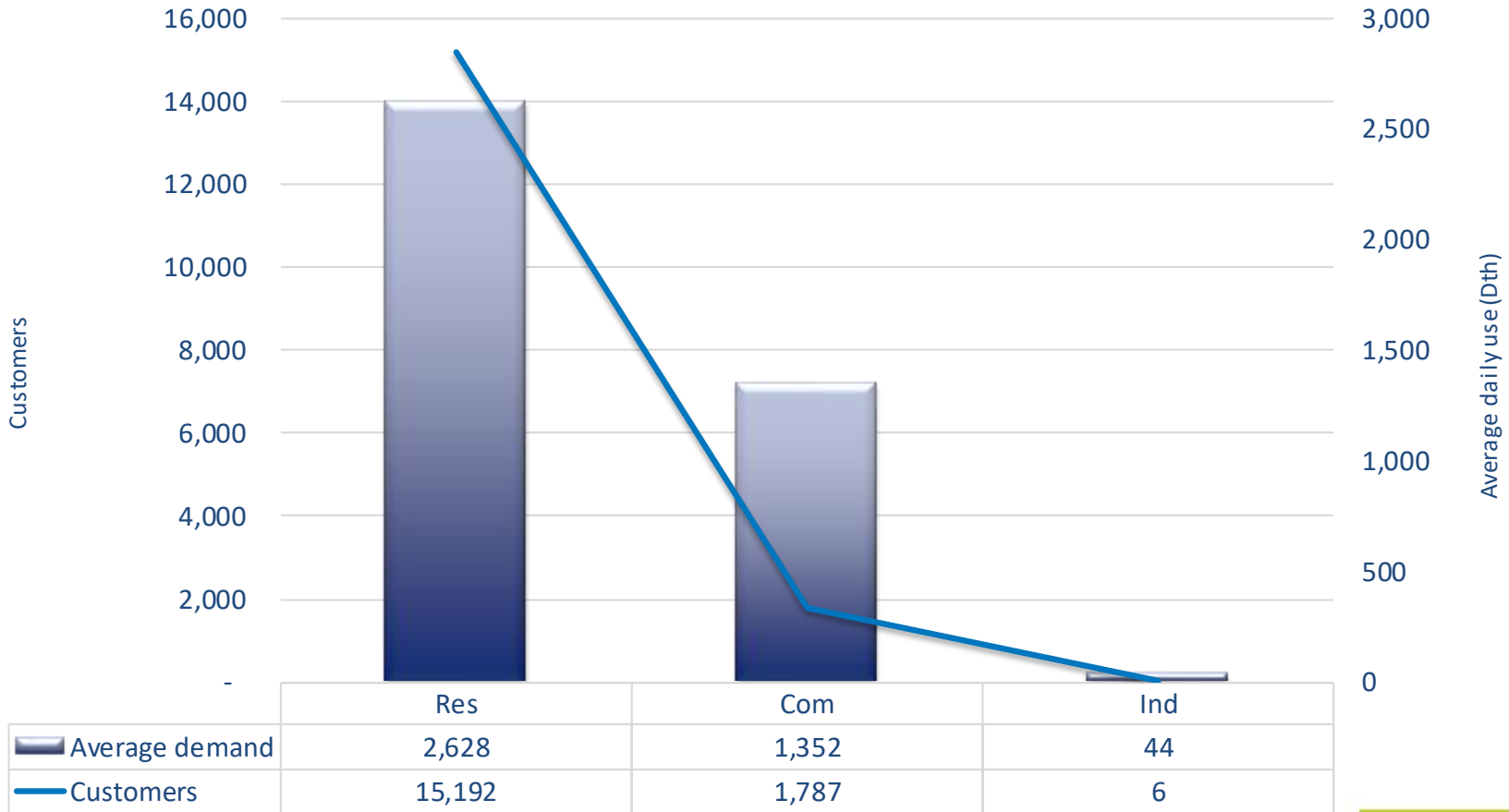

Roseburg

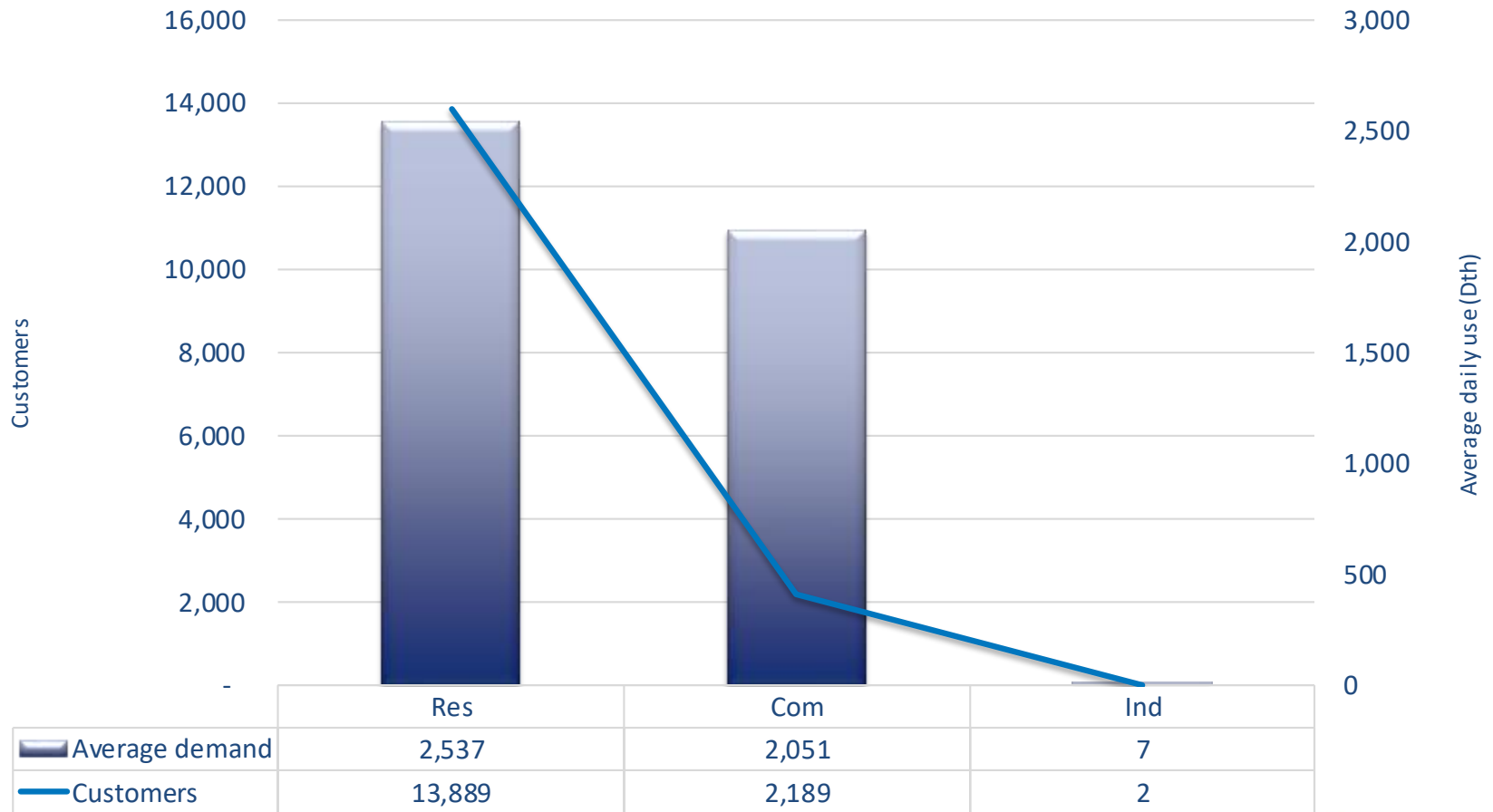

La Grande

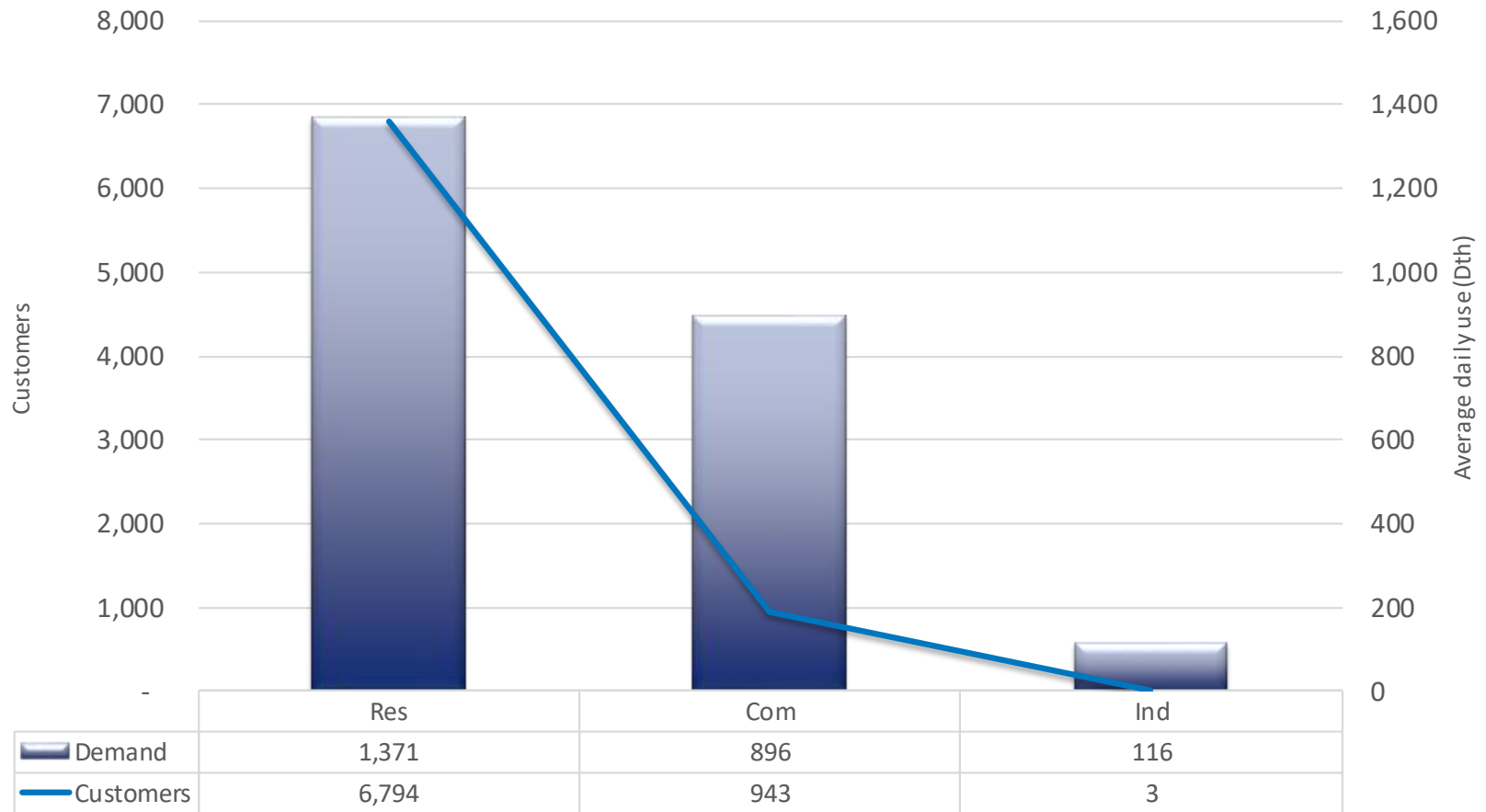

Medford

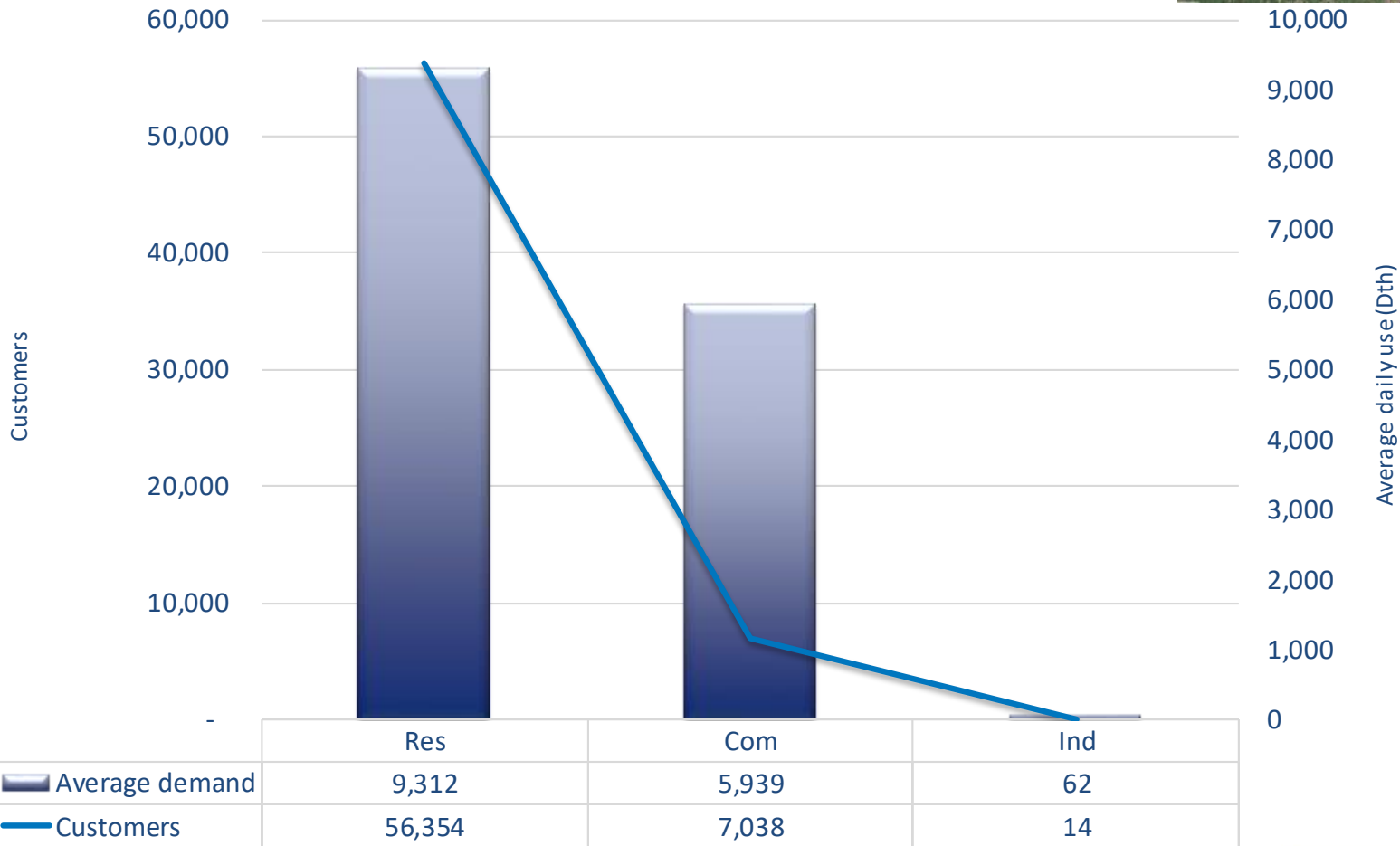

Idaho

Exh. SJK-5

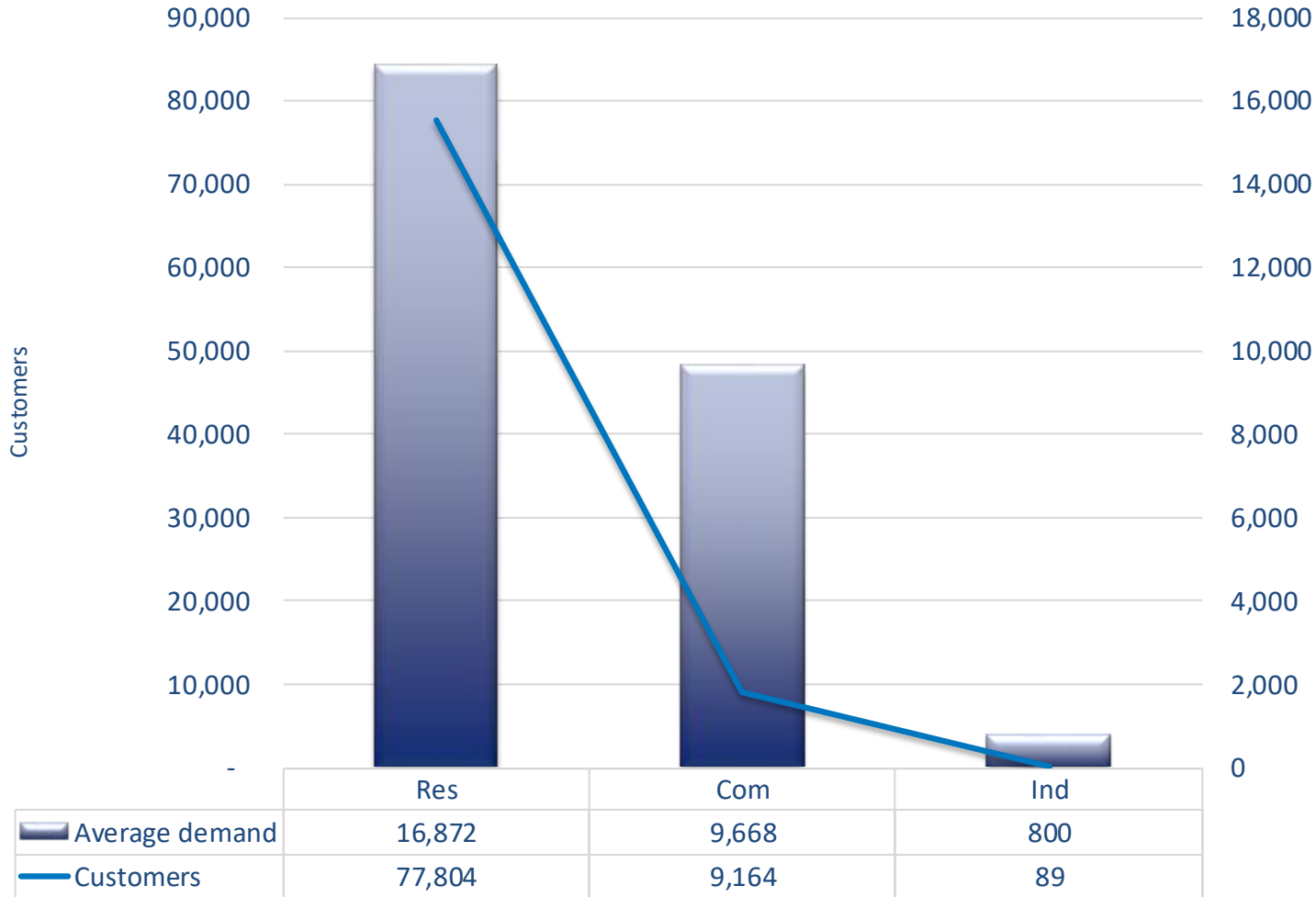

Washington

Exh. SJK-5

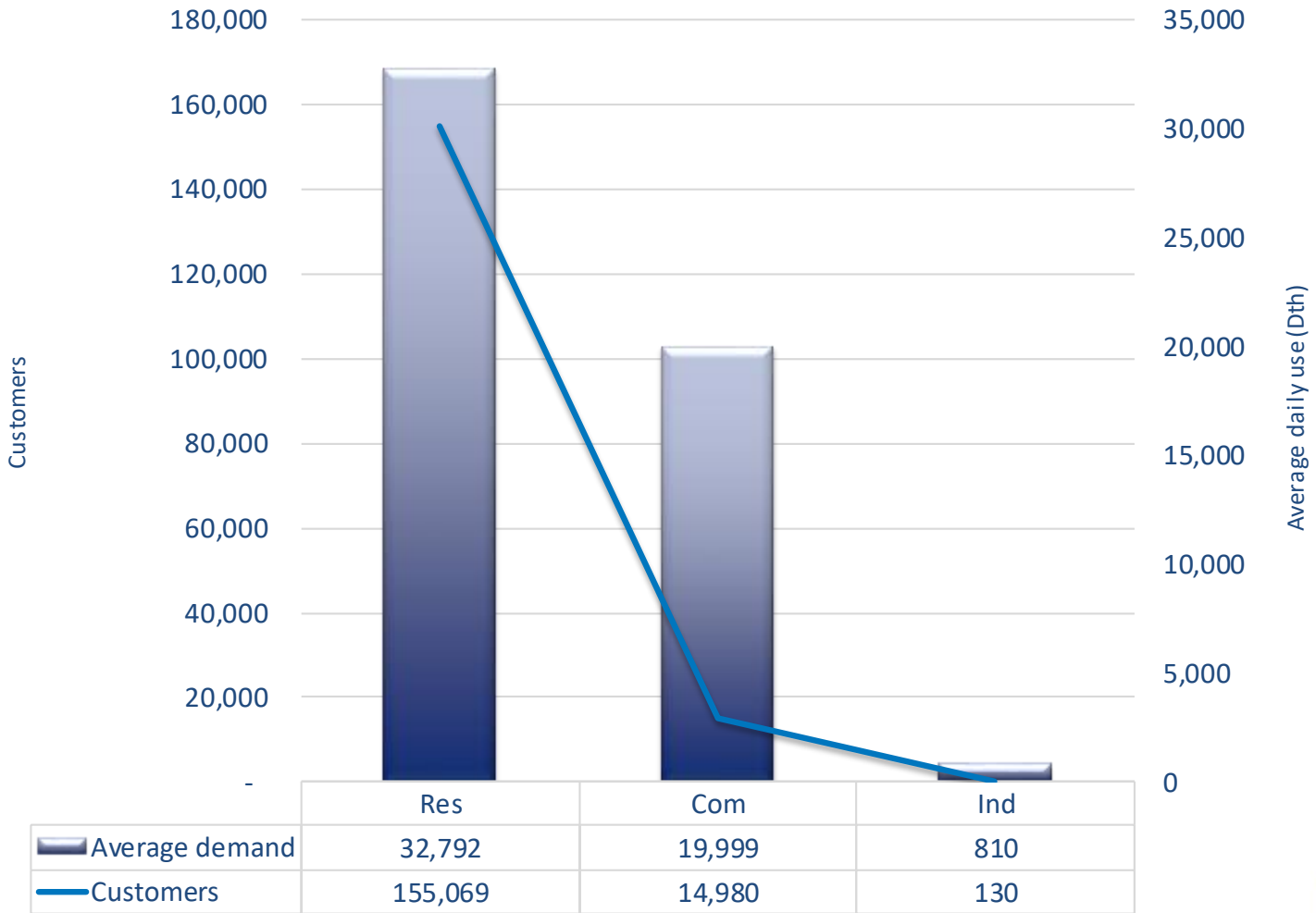
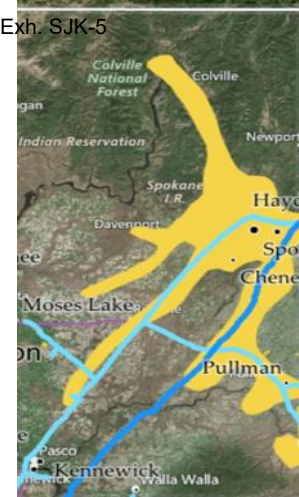

OR Daily Demand Profiles

Medford
Daily Demand

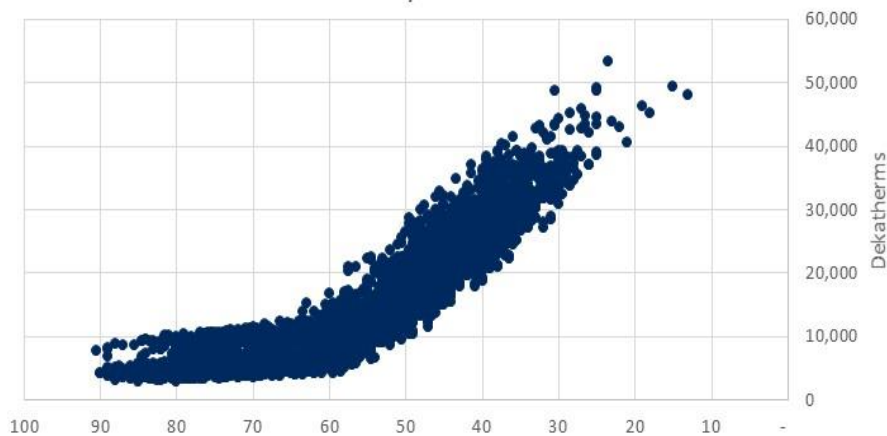

Roseburg
Daily Demand

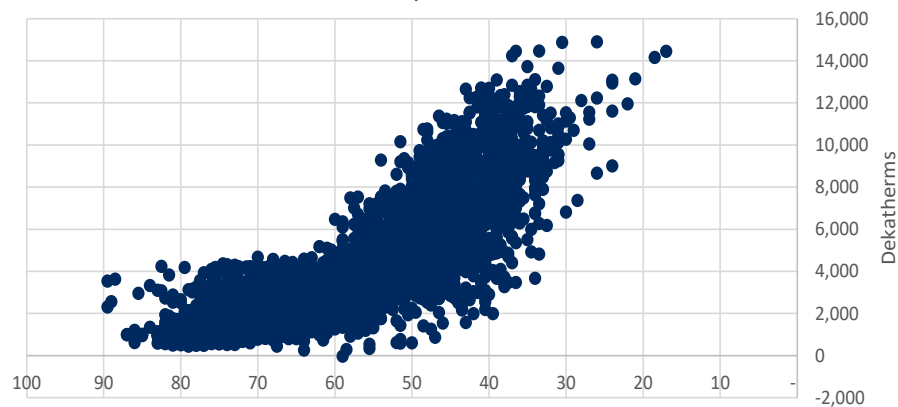

Klamath Falls
Daily Demand

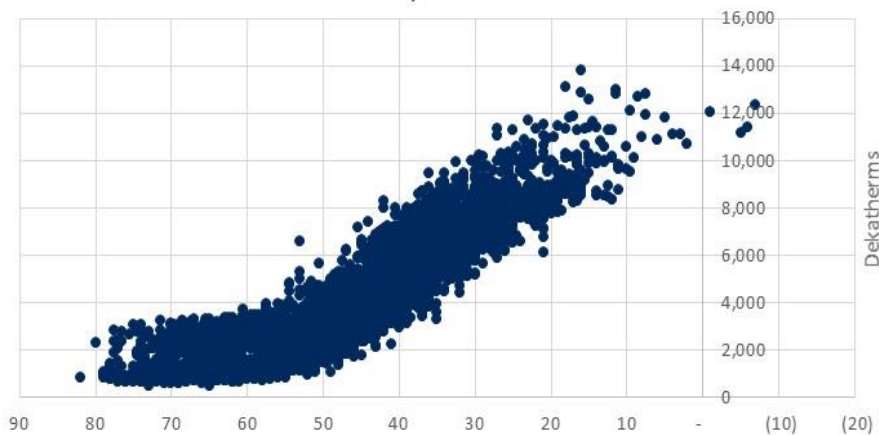

La Grande

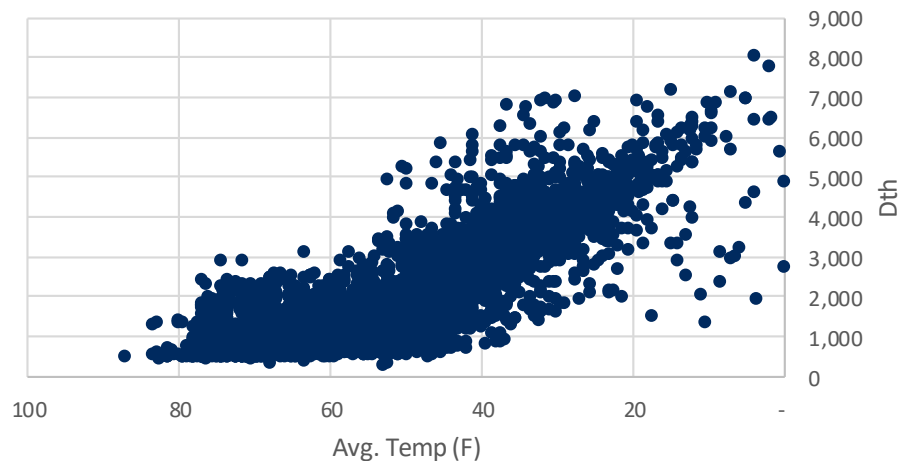

WA-ID Daily Demand Profiles

Idaho Demand

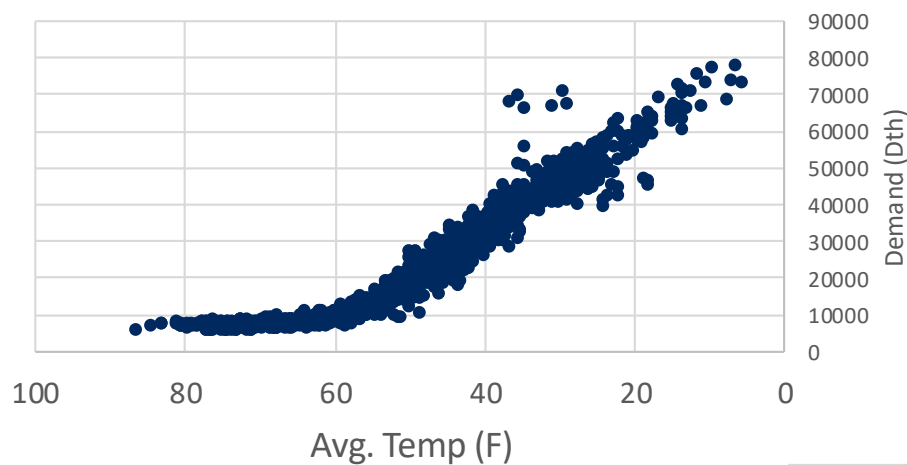

WA Demand

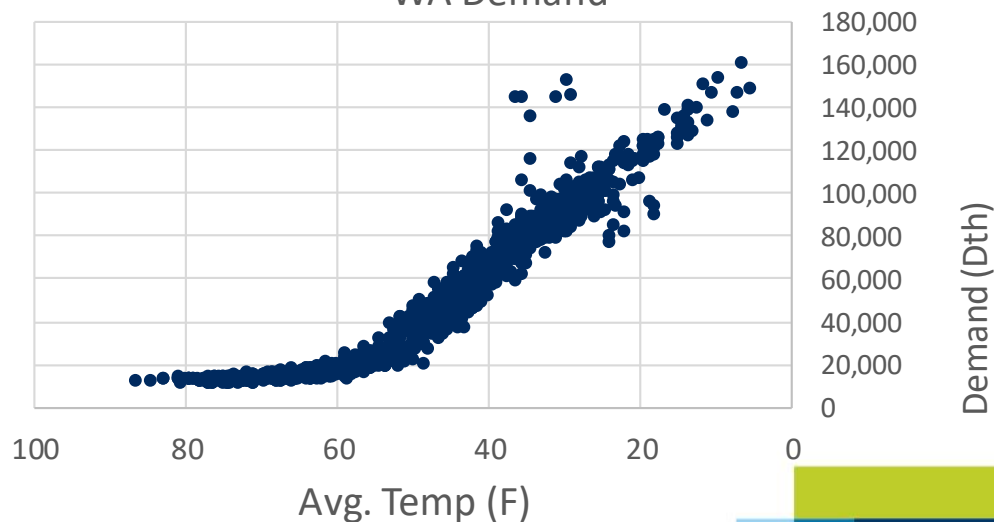



Demand Forecast Methodology

Temperature & Degree Days

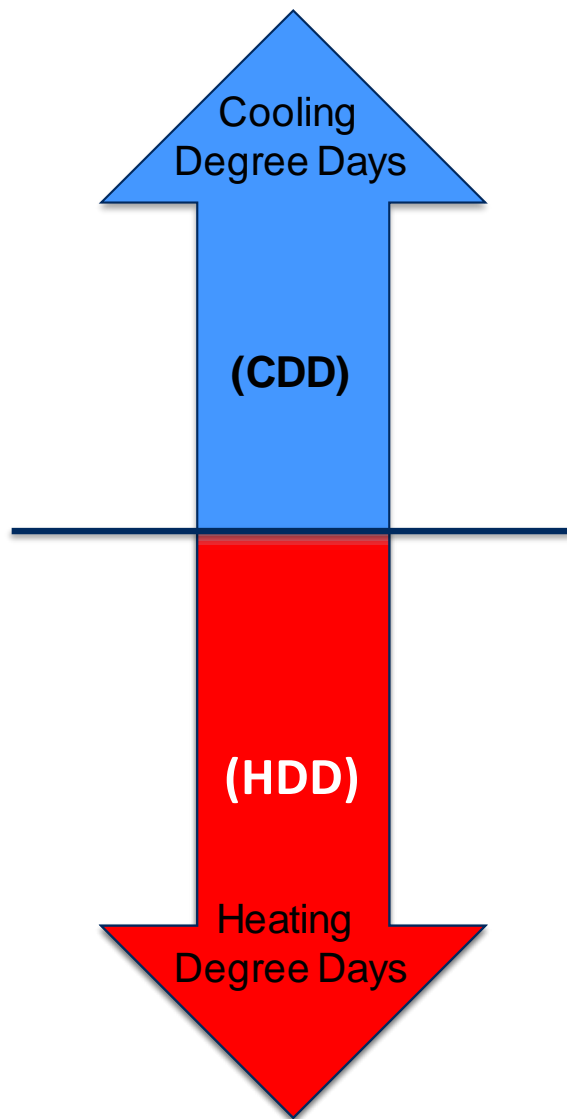

Temp (°F)	=	Degree Days
100	=	35
90	=	25
80	=	15
70	=	5
65	=	0
60	=	5
50	=	15
40	=	25
30	=	35
20	=	45
10	=	55
0	=	65
-10	=	75
-20	=	85

Weather

- NOAA 20 year actual average daily HDD's (2000-2019)
- Peak weather includes two winter storms (5 day duration), one in December and one in February
- Planning Standard
- Sensitivity around planning standard including
 - Normal/Average
 - Monte Carlo simulation

Base Coefficients

Planning Area - Residential Class	2 year	3 year	5 year
Roseburg (Oregon)	0.041949146	0.040148823	0.03765259
Medford (Oregon)	0.04748832	0.047701223	0.04716918
La Grande (Oregon)	0.069994892	0.068986632	0.073506326
Klamath Falls (Oregon)	0.035881027	0.034536108	0.033843554
Idaho	0.048375922	0.046698825	0.046092068
Washington	0.047248771	0.046575066	0.047525773

*Base Coefficients



Heat Coefficients

Planning Area - Residential Class	2 Year	3 Year	5 Year
Roseburg (Oregon)	0.008829	0.008046	0.00699
Medford (Oregon)	0.00639	0.0065	0.006068
La Grande (Oregon)	0.006223	0.007297	0.00665
Klamath Falls (Oregon)	0.005284	0.005268	0.004902
Idaho	0.006445	0.006344	0.005896
Washington	0.006307	0.006313	0.005957

*Avg. of monthly heat coefficient

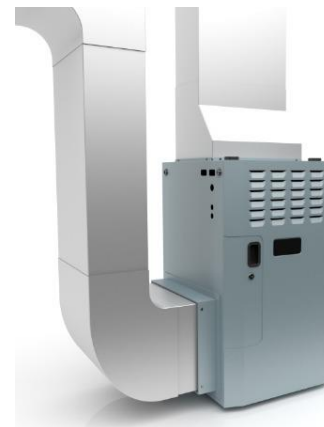

Demand Modeling Equation – a closer look

SENDOUT® requires inputs expressed in the below format to compute daily demand in dekatherms. The **base** and **weather sensitive** usage (degree-day usage) factors are developed outside the model and capture a variety of demand usage assumptions.

Table 3.2 Basic Demand Formula

$\begin{aligned} & \# \text{ of customers } \times \text{ Daily } \mathbf{base} \text{ usage} / \text{ customer} \\ & \mathbf{Plus} \\ & \# \text{ of customers } \times \text{ Daily } \mathbf{weather \ sensitive} \text{ usage} / \text{ customer} \end{aligned}$
--

Developing a Reference Case

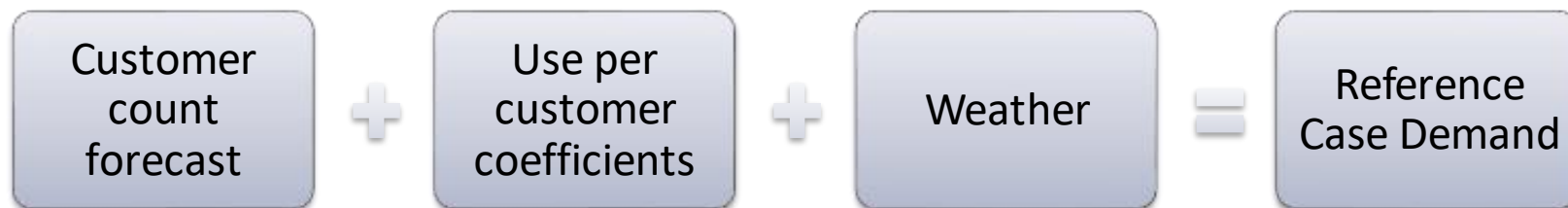

1. Expected customer count forecast by each of the 6 areas
2. Use per customer coefficients –5 year, 3 year or last 2 year average use per HDD per customer
3. Current weather planning standard



Weather Analysis

Z-Stat

- Compare one period to another
- Shows how far from the average the data point falls

Medford Dec-Jan-Feb Temperature Anomaly Histogram

Exh. SJK-5

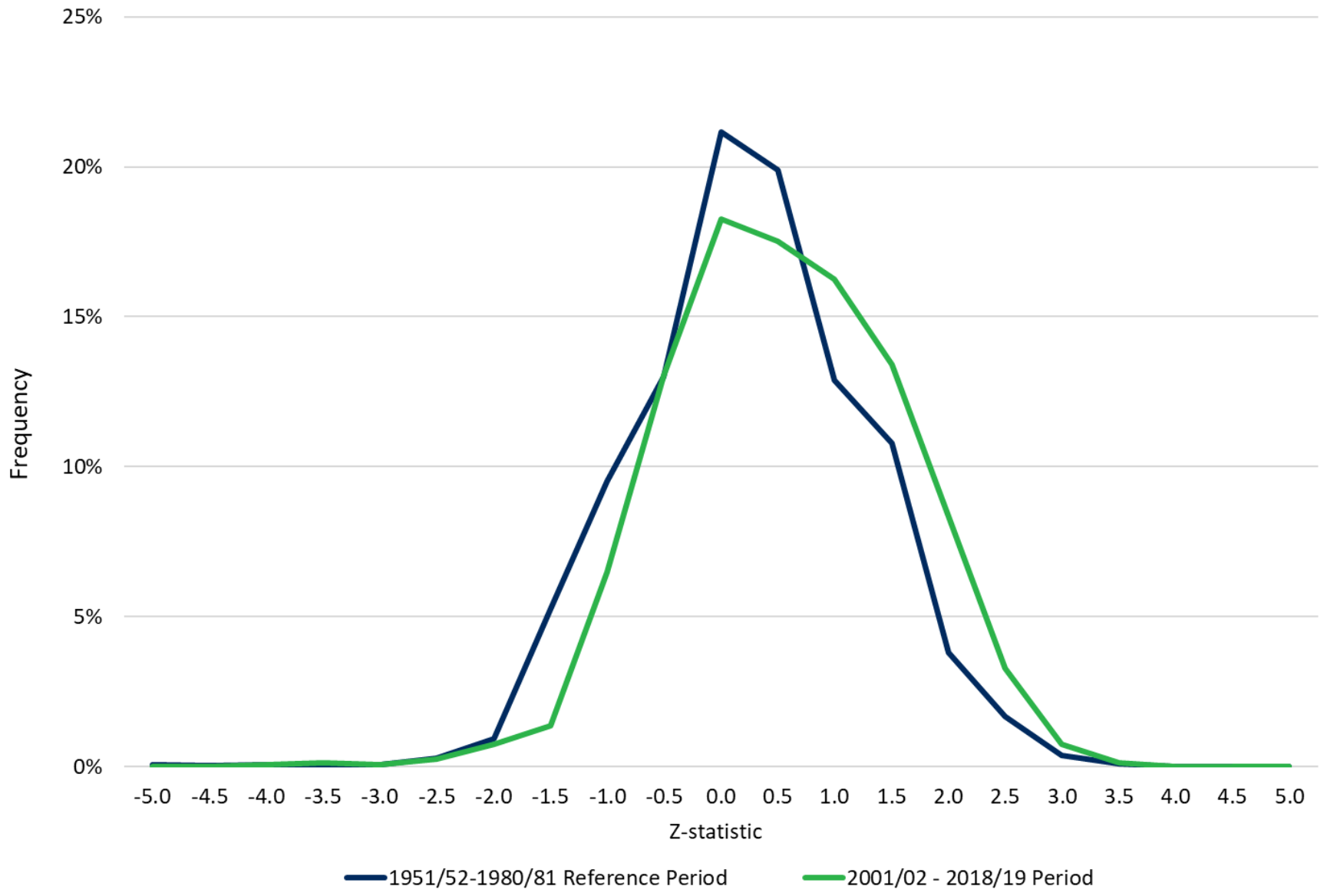

Roseburg Dec-Jan-Feb Temperature Anomaly Histogram

Exh. SJK-5

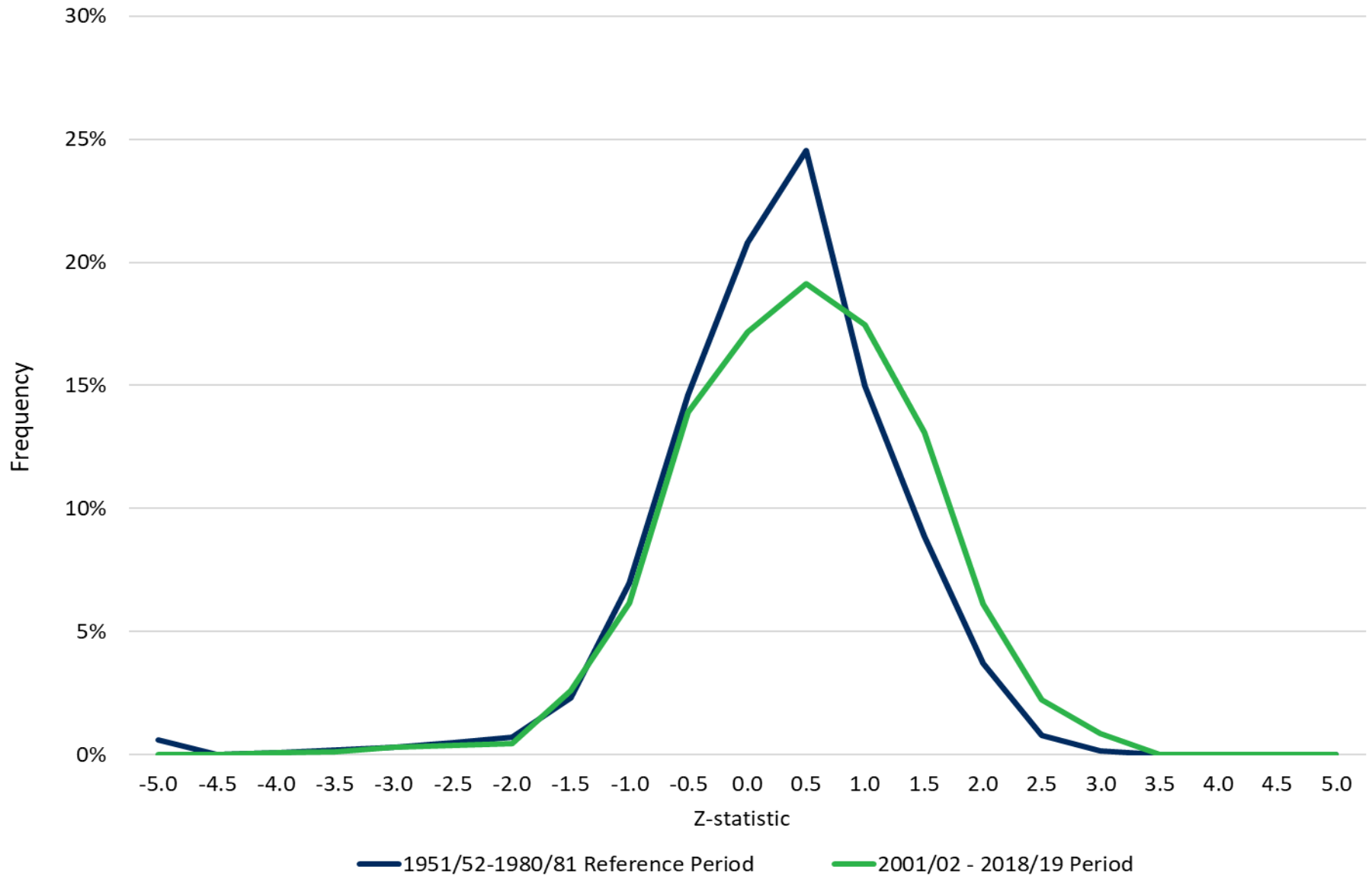

La Grande Dec-Jan-Feb Temperature Anomaly Histogram

Exh. SJK-5

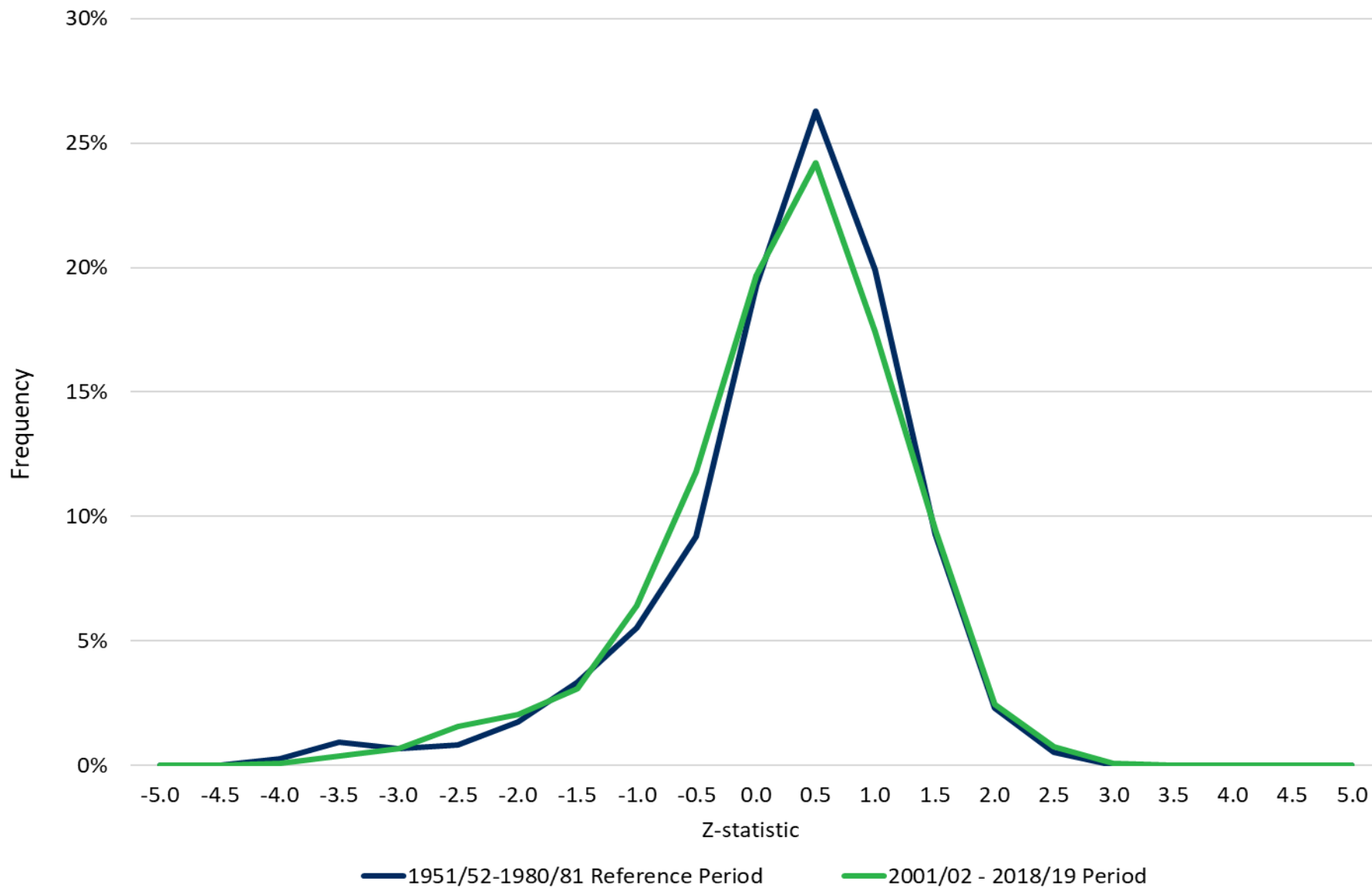

Klamath Falls Dec-Jan-Feb Temperature Anomaly Histogram

Exh. SJK-5

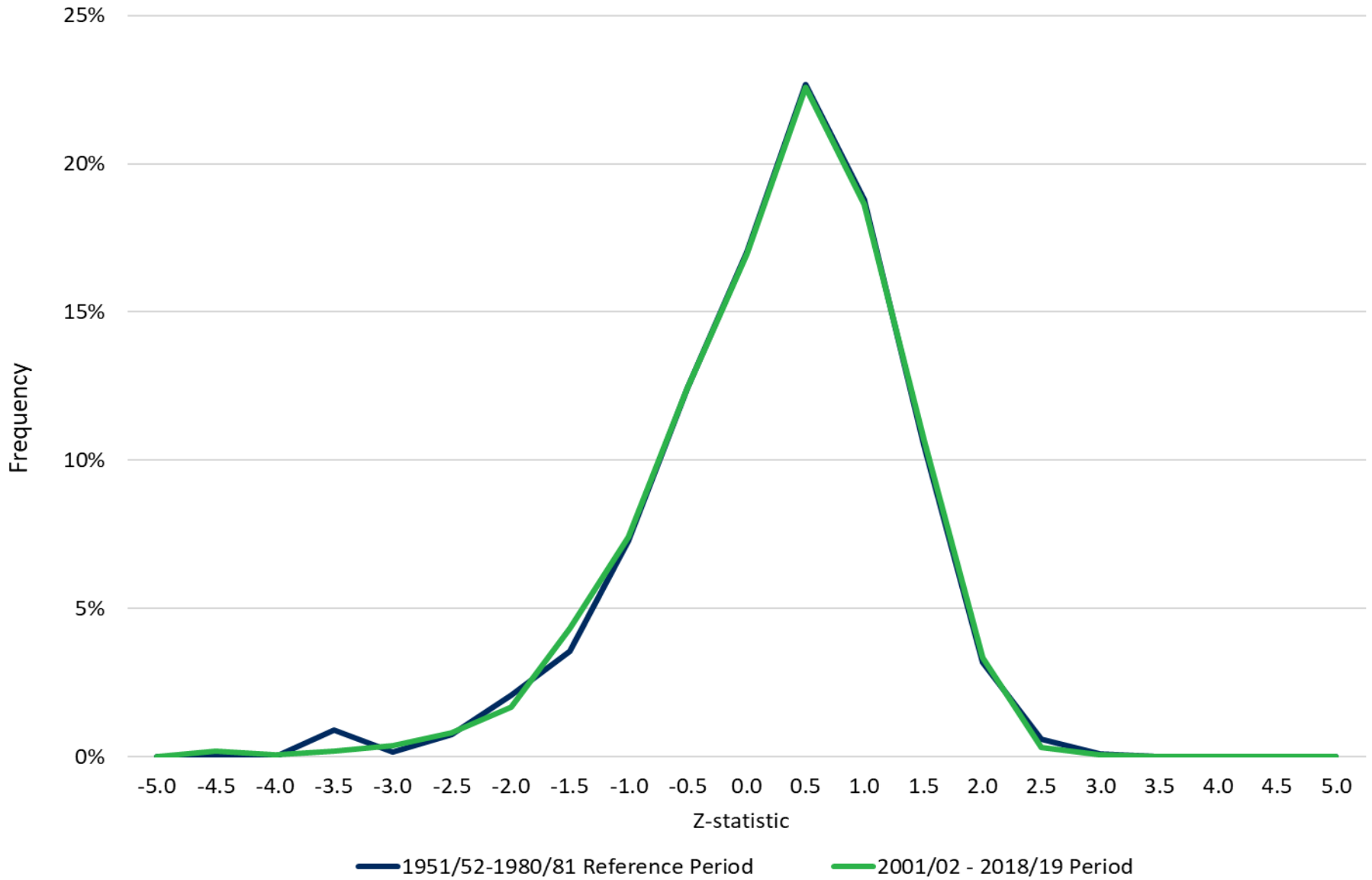

Spokane Dec-Jan-Feb Temperature Anomaly Histogram

Exh. SJK-5

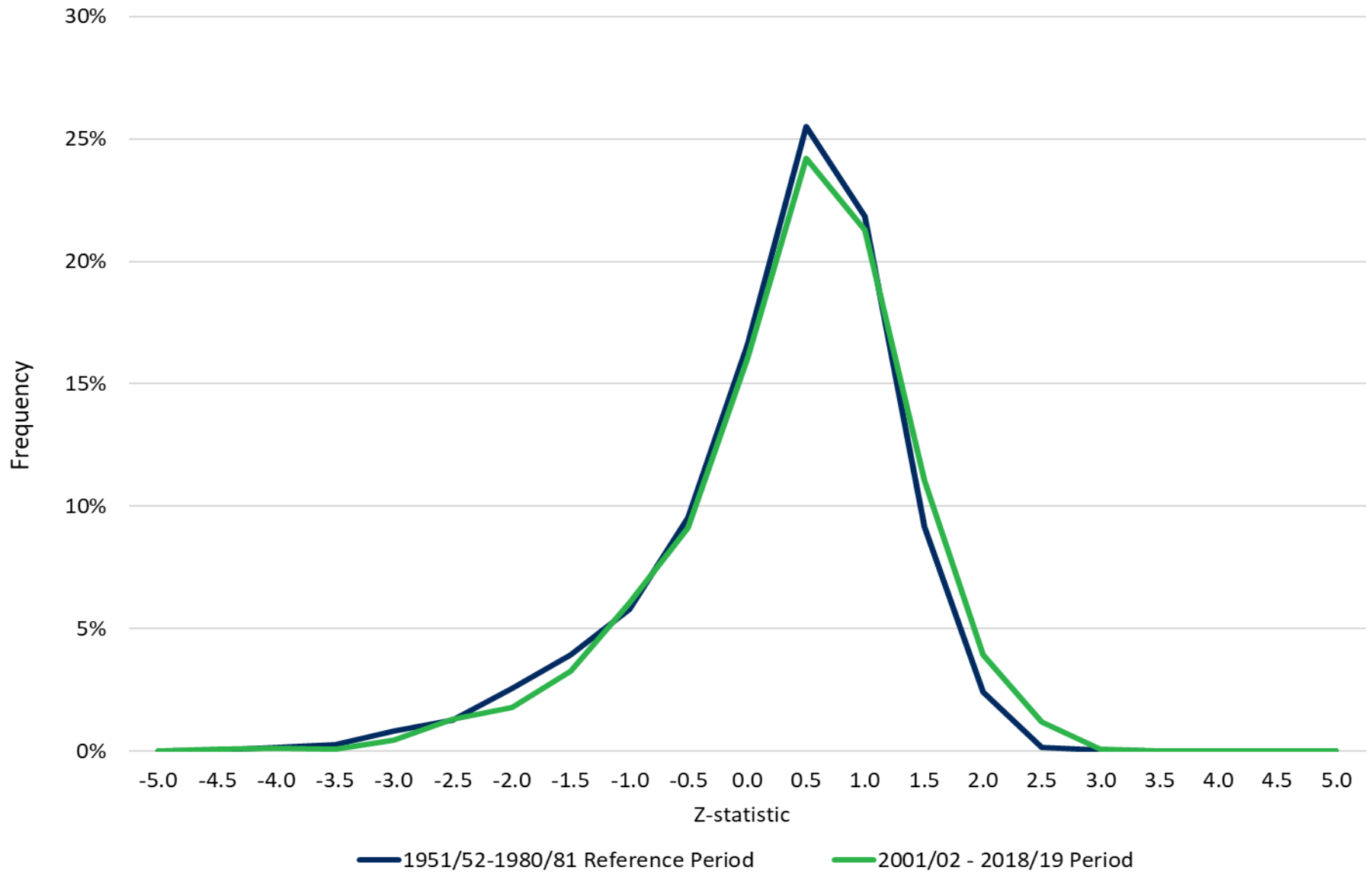

Summary

- Avista's warmer climate locations, Roseburg and Medford, continue to see a shift in temperatures vs. the reference period
- The colder weather climate locations, Klamath Falls, La Grande, Spokane (ID, WA), have maintained the general shape and remain consistent vs. the reference period



Weather Planning Standard

Weather Standard

- Has the potential to significantly change timing of resource needs
- Significant qualitative considerations
 - No infrastructure response time if standard exceeded
 - Significant safety and property damage risks
- Current Peak HDD Planning Standards
 - WA/ID 82
 - Medford 61
 - Roseburg 55
 - Klamath 72
 - La Grande 75



Wind Chill Chart

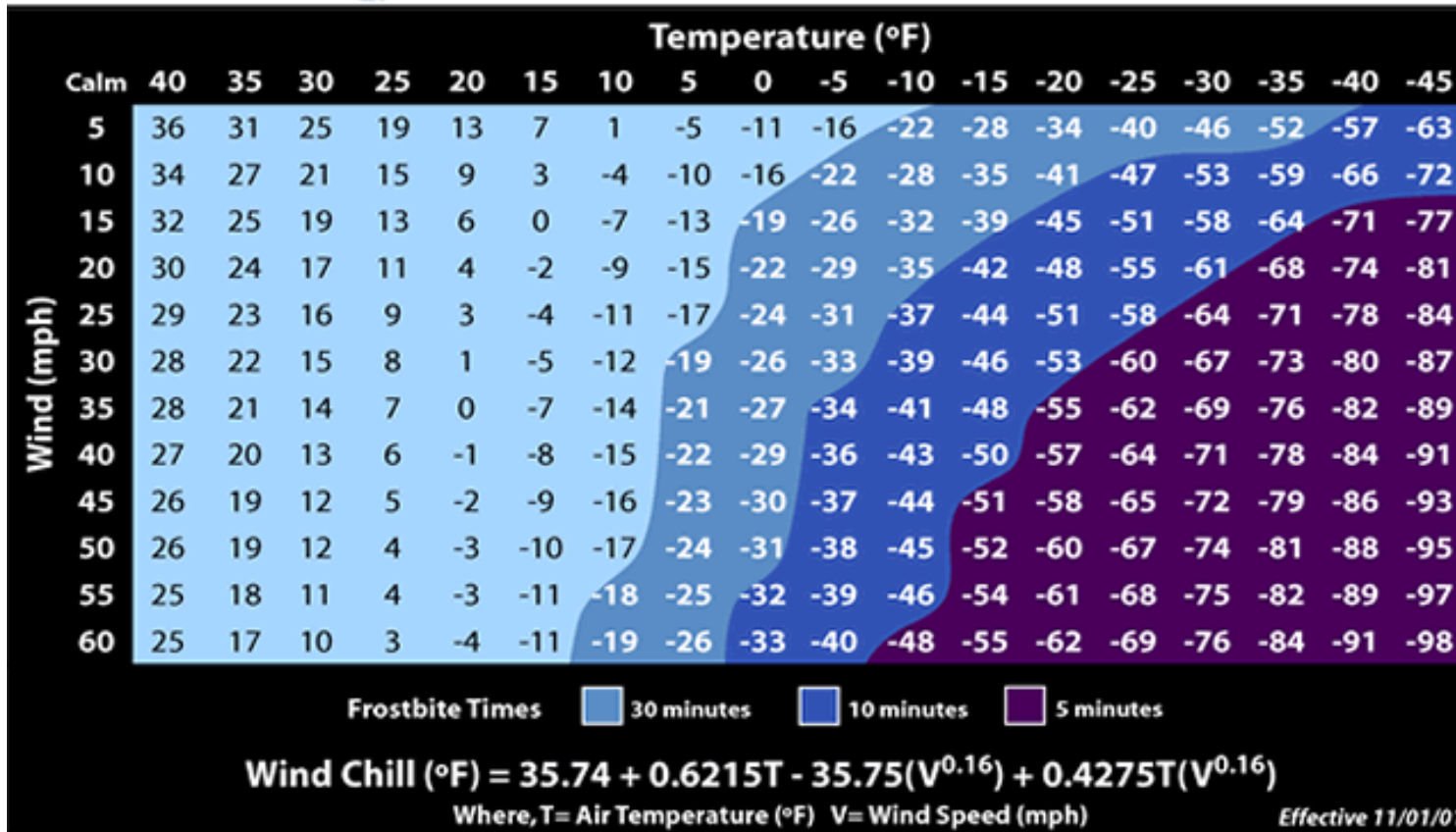

Wind chill effects

- Wind on homes causes two effects. One is wind chill on the exterior of the building and the other is infiltration increases due to the pressure difference caused by wind blowing past the home.
- The greatest effect of wind on heating is low humidity in the home which makes the customers feel like the temperature is 64 degrees when they have the thermostat set at 72 if their humidity is lower than 10% Relative Humidity.

Weather Peak Planning Day alternative

- Coldest Average Day, each year, for the past 30 years combined with a 99% probability

Area	Coldest on Record	99% Probability Avg. Temp	99% Probability Avg. Temp & Wind Chill*
La Grande	-10	-11	-23
Klamath Falls	-7	-9	-16
Medford	4	11	9
Roseburg	10	14	16
Spokane	-17	-12	-26

Risks

- Using wind chill effects combined with a 99% probability produces some drastic changes in peak day planning and may require a large amount of capital to meet those design criteria
- Utilizing a 99% probability means there is a 1 in 100 event where Avista may not be able to meet the demand

Risk around moving WA and ID peak day temps (1,000 simulated futures run)

Draws 1 - 200

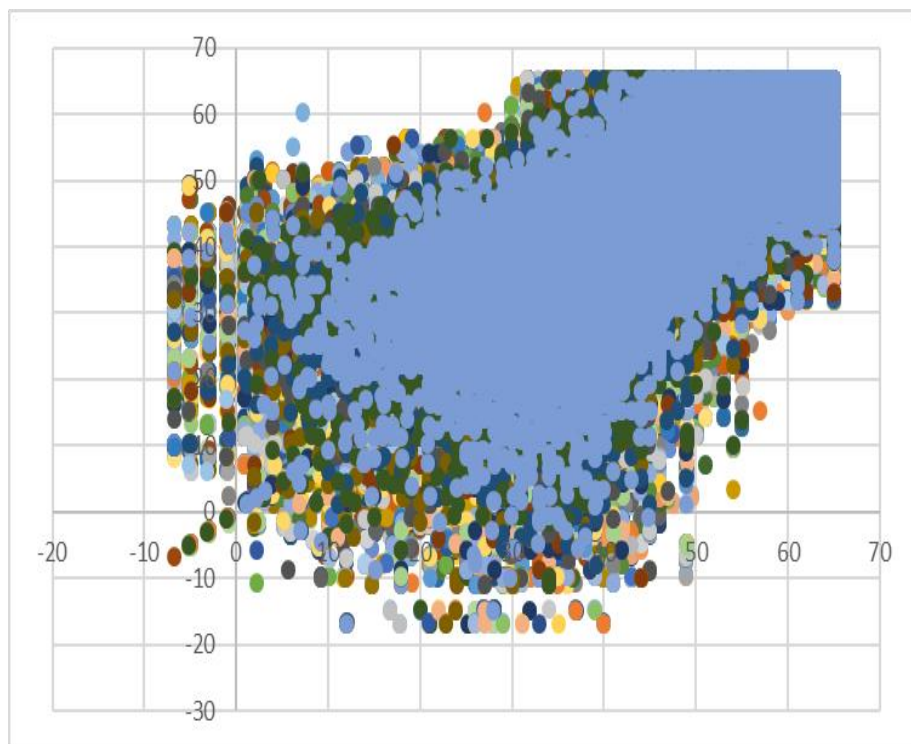

33

Draws 201 - 400

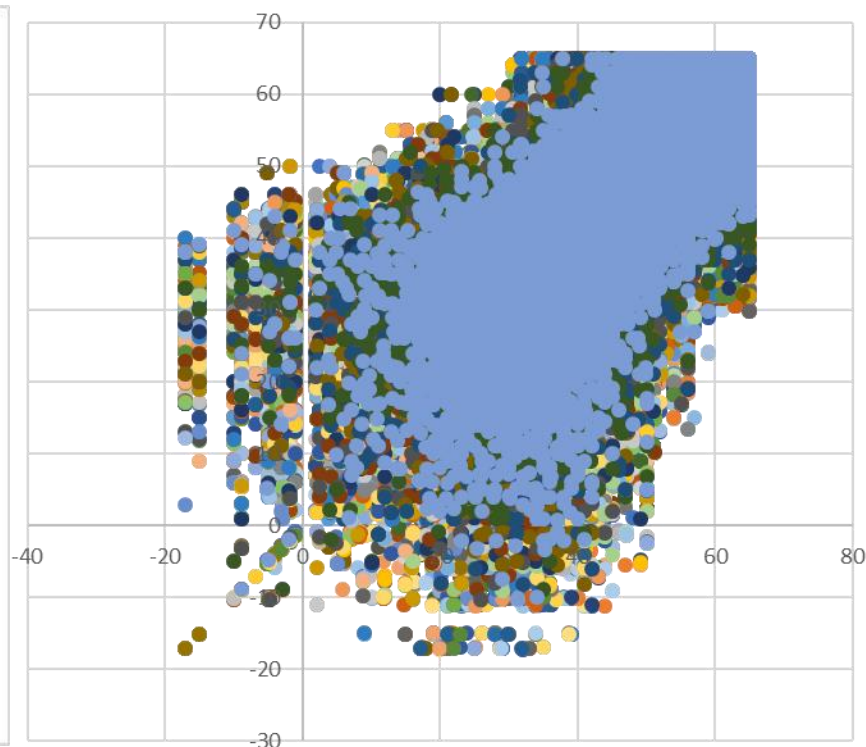

38

Coldest on Record Peak Days
(82 HDD's, or -17 Avg. Temp Fahrenheit)

“Flat Demand” Risk

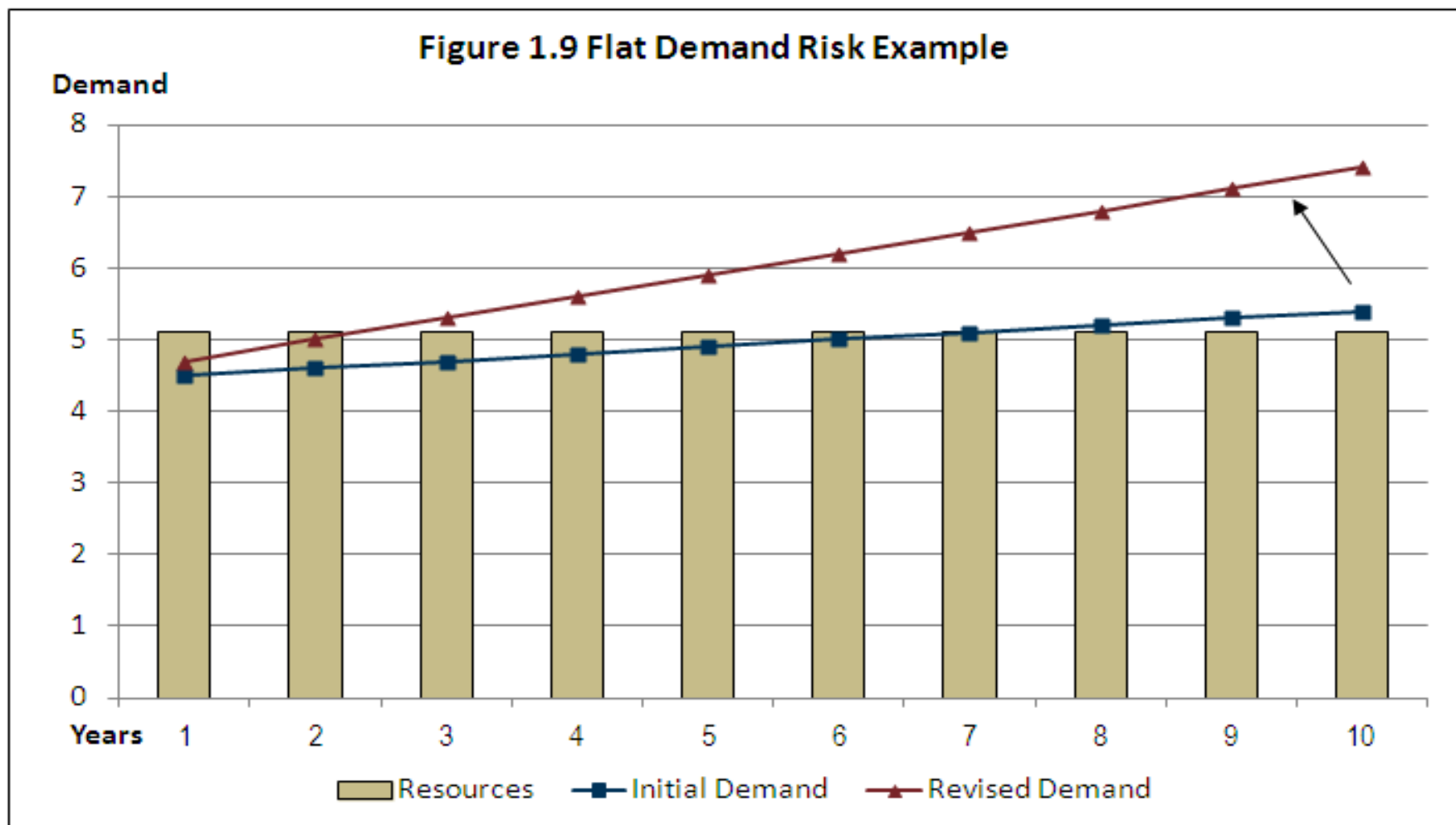

Avista Weather Recommendation

- Utilize coldest day for each of the past 30 years with a 99% probability supply can be fulfilled

Area	99% Probability Avg. Temp
La Grande	-11
Klamath Falls	-9
Medford	11
Roseburg	14
Spokane	-12



Procurement Plan

Hedging Objectives and Goals

Mission

To provide a diversified portfolio of reliable supply and a level of price certainty in volatile markets.

- Avista cannot predict future market prices, however we use experience, market intelligence, and fundamental market analysis to structure and guide our procurement strategies.
- Avista's goal is to develop a plan that utilizes customer resources (storage and transportation), layers in pricing over time for stability (time averaging), allows discretion to take advantage of pricing opportunities should they arise, and appropriately manages risk.

Oversight and Control

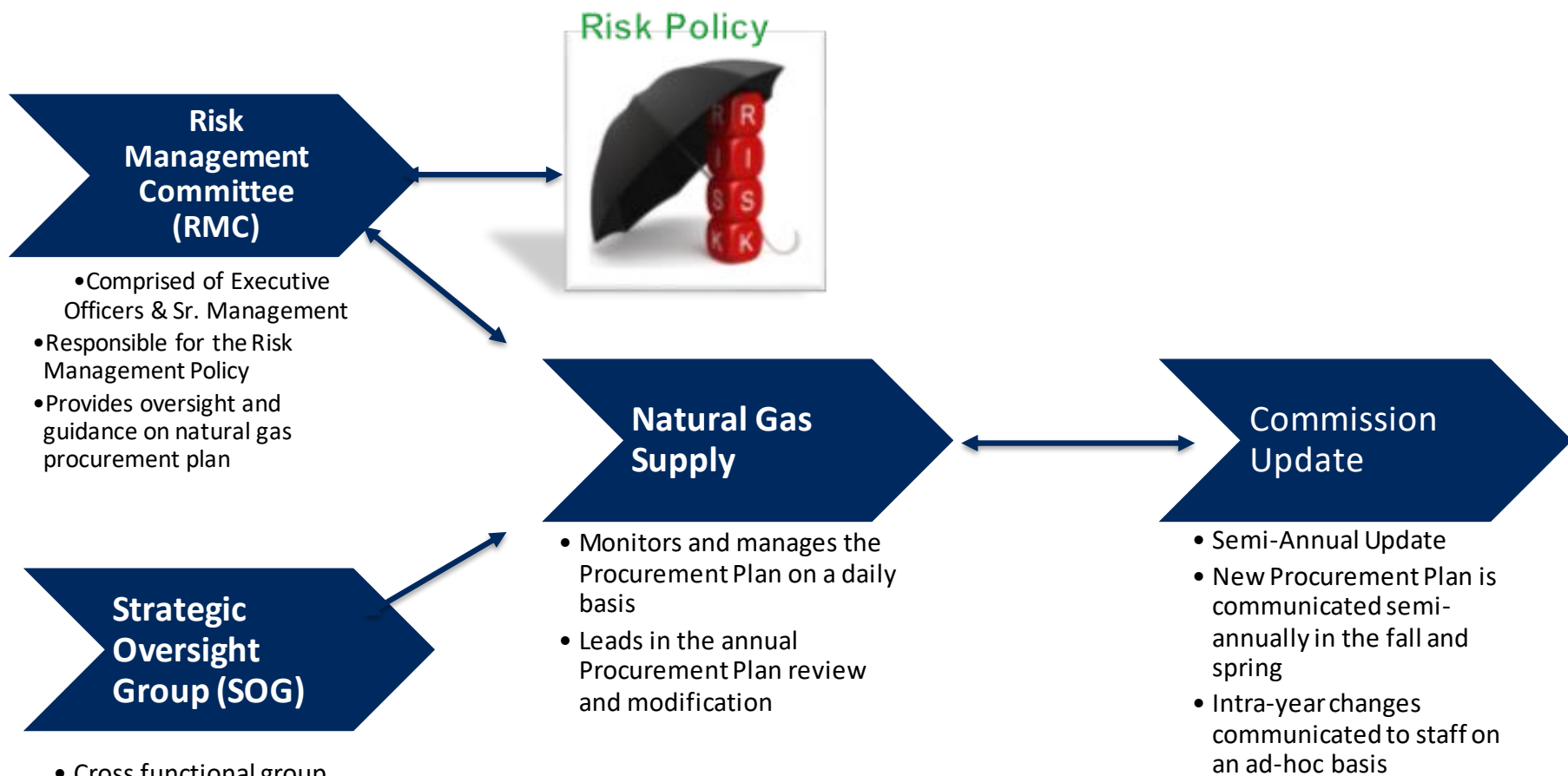

Comprehensive Annual Review of Previous Plan

Review conducted with SOG includes:

- Mission statement and approach
- Current and future market dynamics
- Hedge percentage
- Operative Boundary
- Resources available (i.e. storage and transportation)
- Hedge windows and quantity (how many, how long)
- Storage utilization
- Analysis (volatility, past performance, scenarios, risk)

A Thorough Evaluation of Risks



AECO Daily Volatility

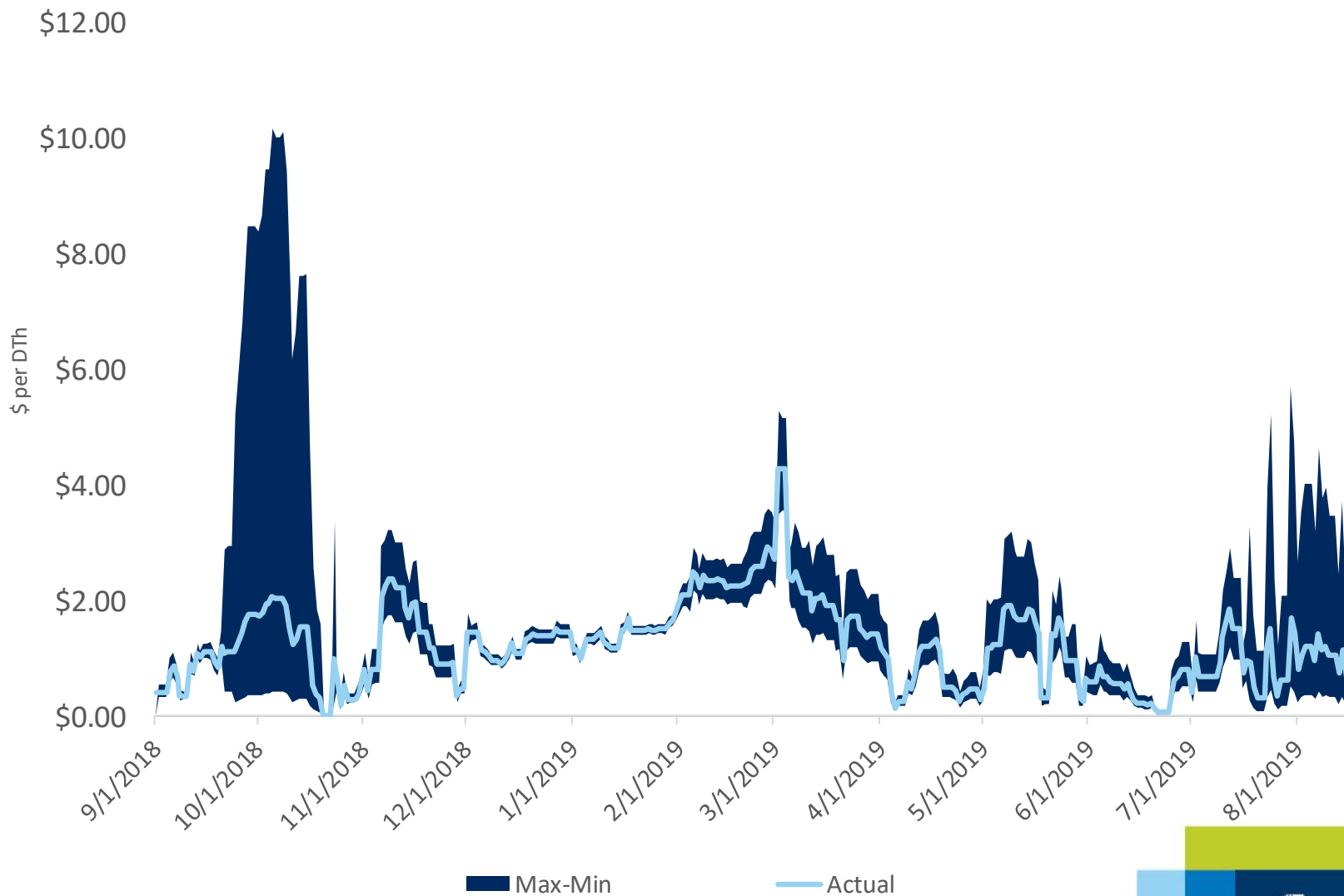

Natural Gas Procurement Plan vs. System Demand November 2019 through October 2020

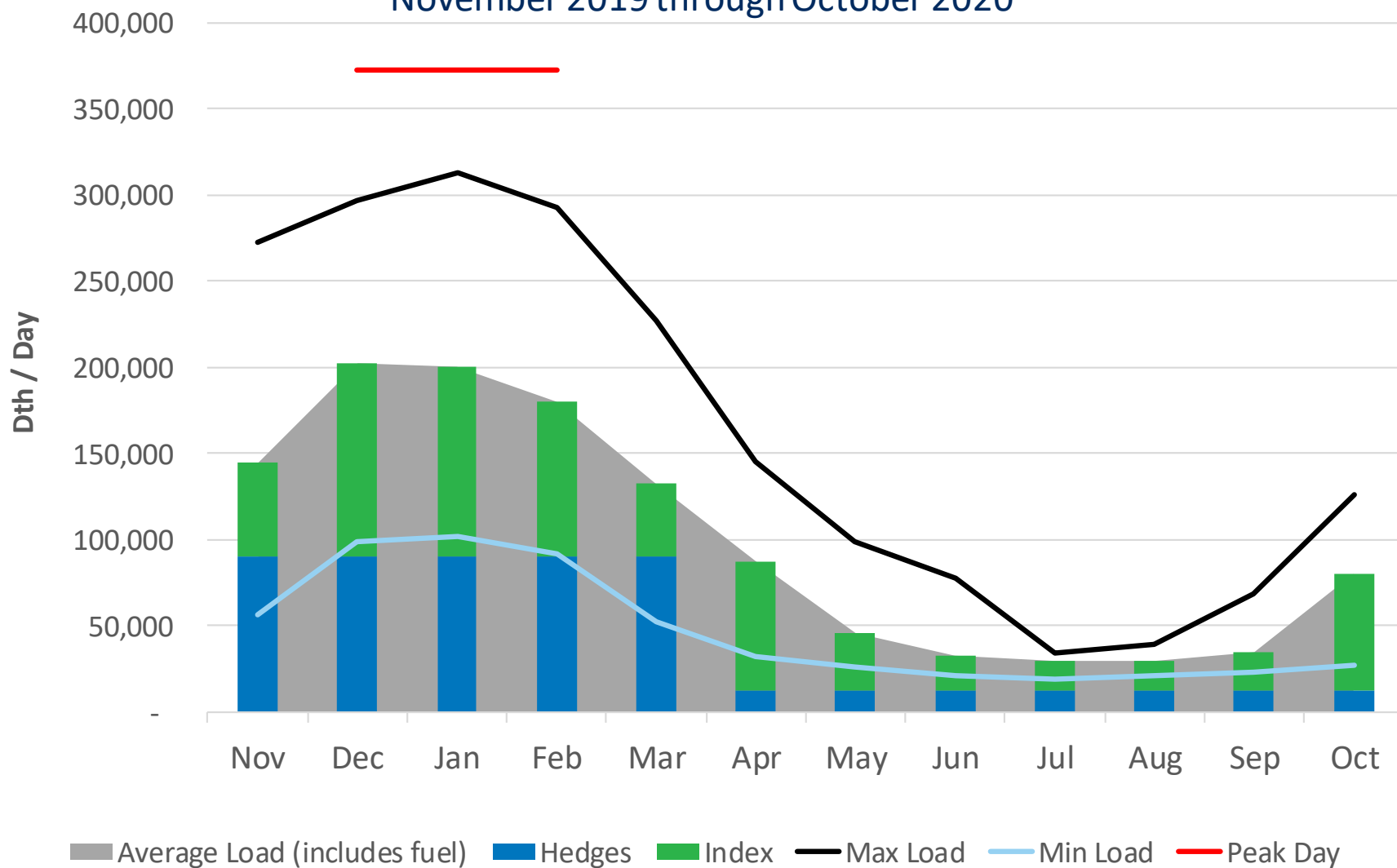

Plan Overview

Dynamic Window Hedge (DWH) Plan

- Manages hedges based on average volumetric load
- Firm local distribution customers only
- **Delivery Periods:** Hedges up to 3 years out into the future from the prompt month in monthly and/or seasonal timeframes
- **Supply Basins:** Windows will use VAR as a way to determine the best basin for a hedge. (AECO, Rockies, Sumas).

Risk Responsive Hedging Tool (RRHT)

- Manages all hedges in the portfolio based on a financial position
 - Transport optimization hedges
 - Storage optimization hedges
 - LDC hedges from the DWH program
- Incorporates the financial value at risk (VaR) as a daily position based on current firm supply side assets combined with price volatility at each futures market basin

Dynamic Window Hedging

May 8, 2020

	Physical Positions			Dynamic Window Hedging									
	Load Estimate (DTh/Day)	Completed Hedges (DTh/Day)	Net Position (DTh/Day)	Window Hedging Threshold	Load Hedged (%)	Hedges Left	Set Date	Expire Date	Low Price Trigger (\$/DTh)	Today's Price (\$/DTh)	High Price Trigger (\$/DTh)	Hedge Required (DTh/Day)	Preferred Basin
June-20	-33,221	12,500	-20,721	40%	38%	0							
July-20	-29,585	12,500	-17,085	40%	42%	0							
August-20	-29,623	12,500	-17,123	40%	42%	0							
September-20	-37,700	15,000	-22,700	40%	40%	0							
October-20	-84,793	27,500	-57,293	40%	32%	3	05/01/20	06/11/20	1.52	1.67	2.08		AECO
Nov20-Mar21	-169,784	85,000	-84,784	33%	50%	0							
Apr21-Oct21	-52,143	12,500	-39,643	23%	24%	0							
Nov21-Mar22	-175,136	37,500	-137,636	33%	21%	8	04/22/20	06/27/20	1.86	2.01	2.22		AECO
Apr22-Oct22	-52,700	5,000	-47,700	23%	9%	3	04/23/20	12/05/20	1.34	1.59	1.93		AECO
Nov22-Mar23	-177,261	2,500	-174,761	33%	1%	22	04/09/20	05/20/20	1.78	1.86	1.95		AECO



Risk Responsive Hedging Tool

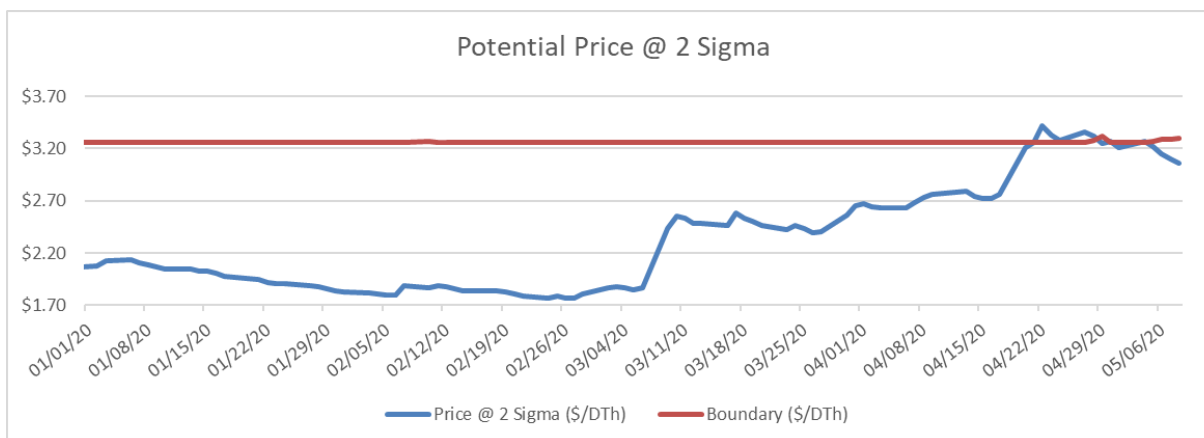
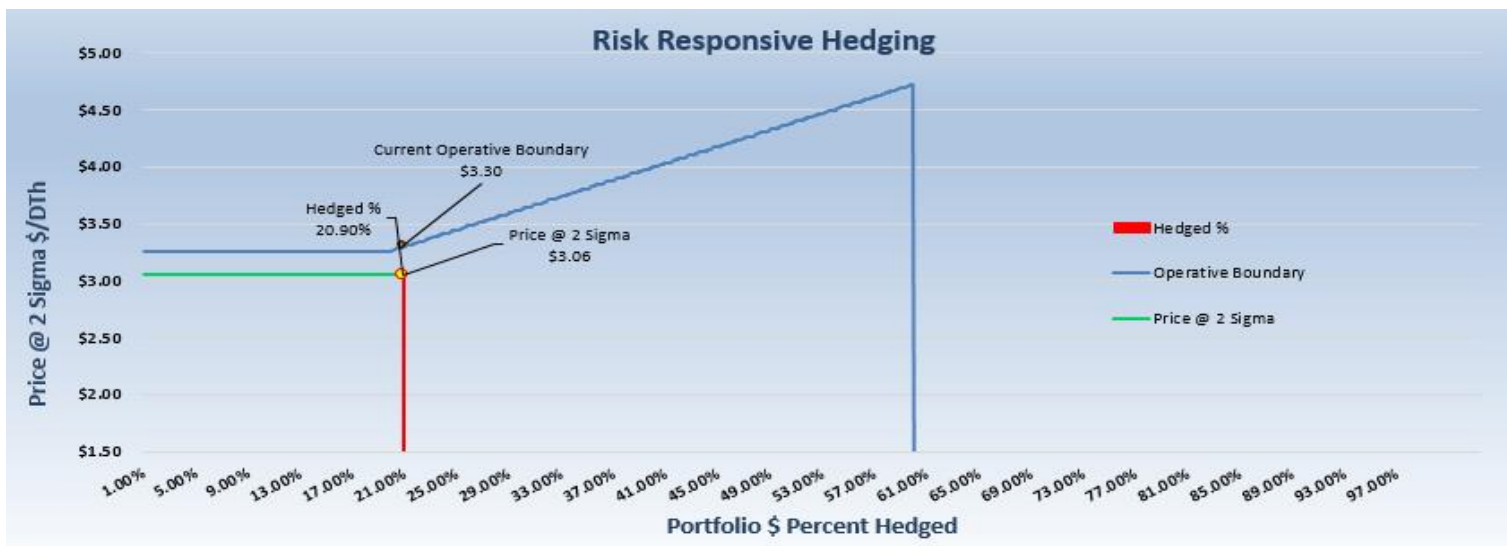



Optimization

Avista Gas Supply Asset Optimization

- Storage Optimization.
 - Utilize Avista owned portion of Jackson Prairie storage facility
 - Maintain a peak day capability in order to serve needed demand from the facility during a peak event.
 - Optimize excess capacity through arbitrage between daily prices and forward months as well as between different forward months.
- Transport Optimization.
 - Avista owns transport capacity sufficient to serve peak day load. Unused capacity is optimized by purchasing/selling gas at different hubs to capture locational price spreads.

Storage Optimization Examples

- Day ahead market arbitrage with forward month
Purchase: daily sumas 75,000 dth for \$1.45/dth.
Sale: 75,000 dth October 2020 Sumas for \$2.48/dth.
Realized arbitrage value: $\$1.03 \times 75,000 = \$77,250$
- Arbitrage between different forward months
Purchase: Q3 2020 sumas 225,000 dth for \$1.81
Sale: Q1 2021 sumas 225,000 dth for \$3.47
Realized arbitrage value : $\$1.66 \times 225,000 = \$373,500$

Transport Optimization

- Transport Capacity in excess of Avista core load can be optimized to reduce customer costs.
- Optimization can be done in either the daily or forward markets

Example:

Purchase: 30,000 dth AECO for \$2.00/dth

Sale: 30,000 dth Malin for \$2.30/dth
 Realized cost reduction to customers:
 $\$0.30 \times 30,000 = \$9,000$

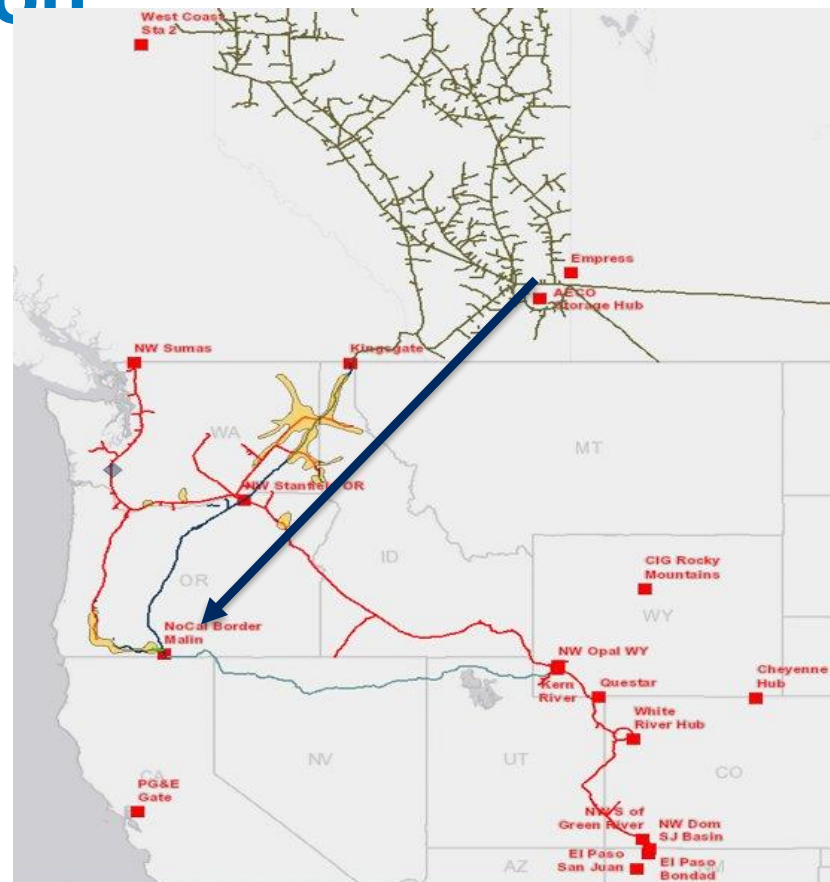

Risks

- Operational Flow Orders:
 - NW Pipeline may require the use of JP storage gas to satisfy OFO's.
 - May require additional purchases from market to replace storage inventory.
- Unplanned maintenance:
 - Unexpected reductions to pipeline capacity or reduced access to storage may limit optimization activity
- Damage or failure of infrastructure



2020 Natural Gas IRP Energy Efficiency

Ryan Finesilver – Energy Efficiency Planning and Analytics Manager
First Technical Advisory Committee Meeting

Team Roles



Planning & Analytics Team



Applied Energy Group (AEG)



Gas Supply



Oregon DSM Programs

Alphabet Soup



- CPA: Conservation Potential Assessment
- IRP: Integrated Resource Plan
- AEG: Applied Energy Group
- IPUC: Idaho Public Utility Commission
- TRC: Total Resource Cost Test
- UCT: Utility Cost Test
- UTC: Utilities and Transportation Commission

The CPA within the IRP is done by AEG and as per the UTC, is according to the TRC but the IPUC requires the UCT.

Who Energy Efficiency Serves

Three Jurisdictions

- Washington
- Idaho
- Oregon (ETO except for Low-Income)



Multiple Customer Segments

- Residential
- Industrial/Commercial
- Low-Income Residential

The Company's Infrastructure

- Aids in reducing overall capacity
- Defers capital investments



Energy Efficiency Funding – Natural Gas

SCHEDULE 191

DEMAND SIDE MANAGEMENT RATE ADJUSTMENT - WASHINGTON

APPLICABLE:

To Customers in the State of Washington where the Company has natural gas service available. This Demand Side Management Rate Adjustment or Rate Adjustment shall be applicable to all retail customers taking service under Schedules 101, 111, 112, 121, 122, 131, and 132. This Rate Adjustment is designed to recover costs incurred by the Company associated with providing Demand Side Management services and programs to customers.

MONTHLY RATE:

The energy charges of the individual rate schedules are to be increased by the following amounts:

Schedule 101	\$0.03472 per Therm
Schedule 111 & 112	\$0.02475 per Therm

Tariff percentage of customer bill by state:

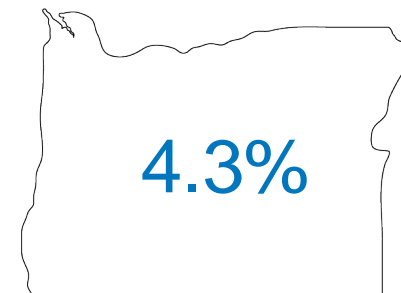
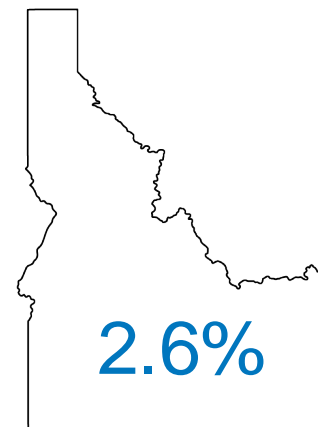
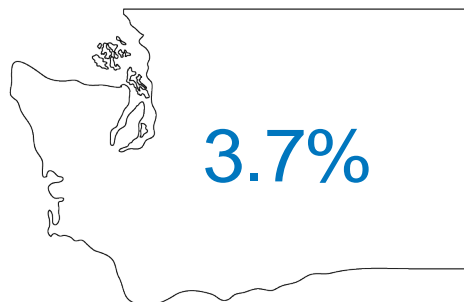

\$8.4 Million
Annual
Funding
 (2019)



WA Gas Targets to Actual Savings

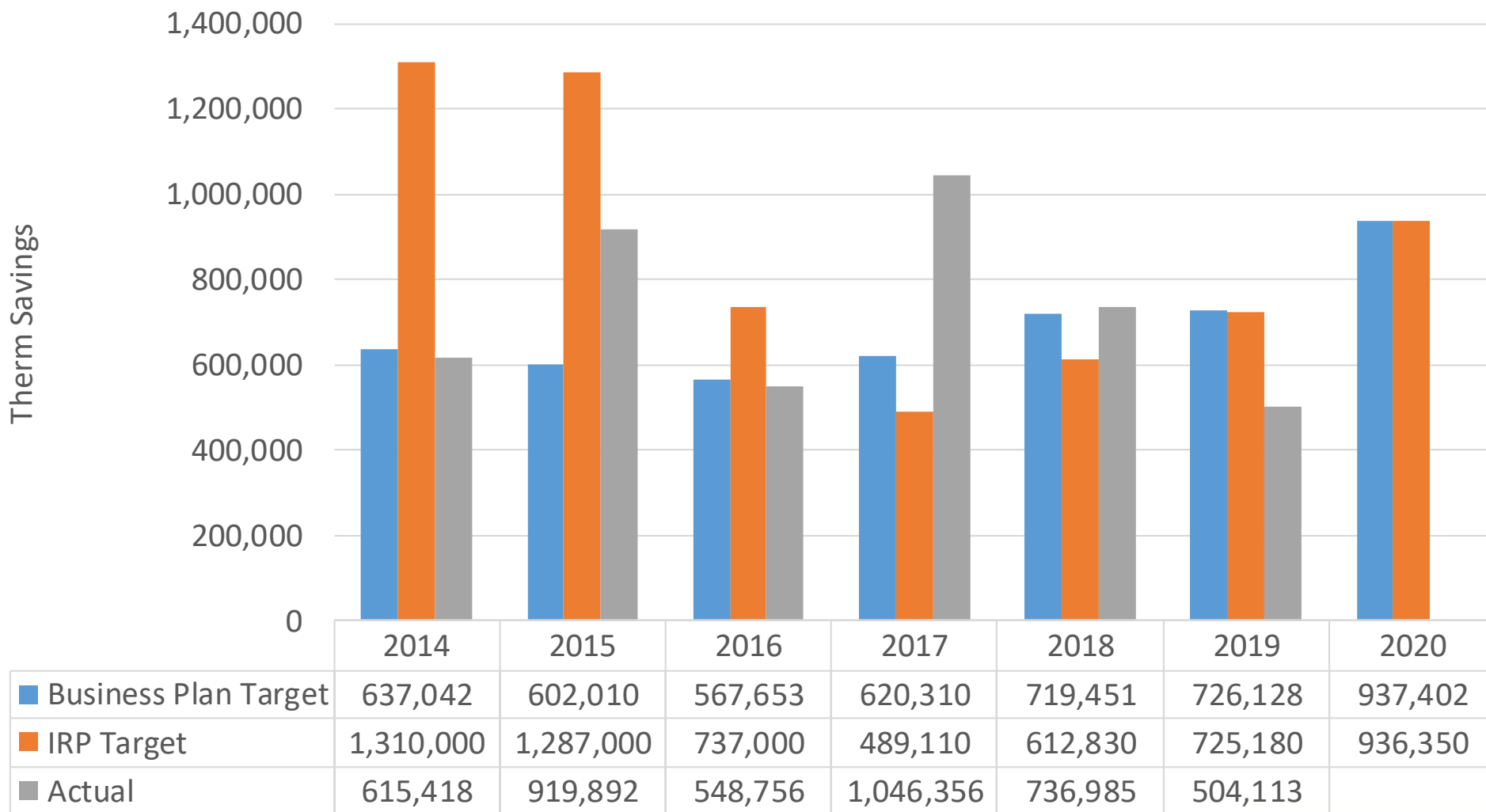

ID Gas Targets to Actual Savings

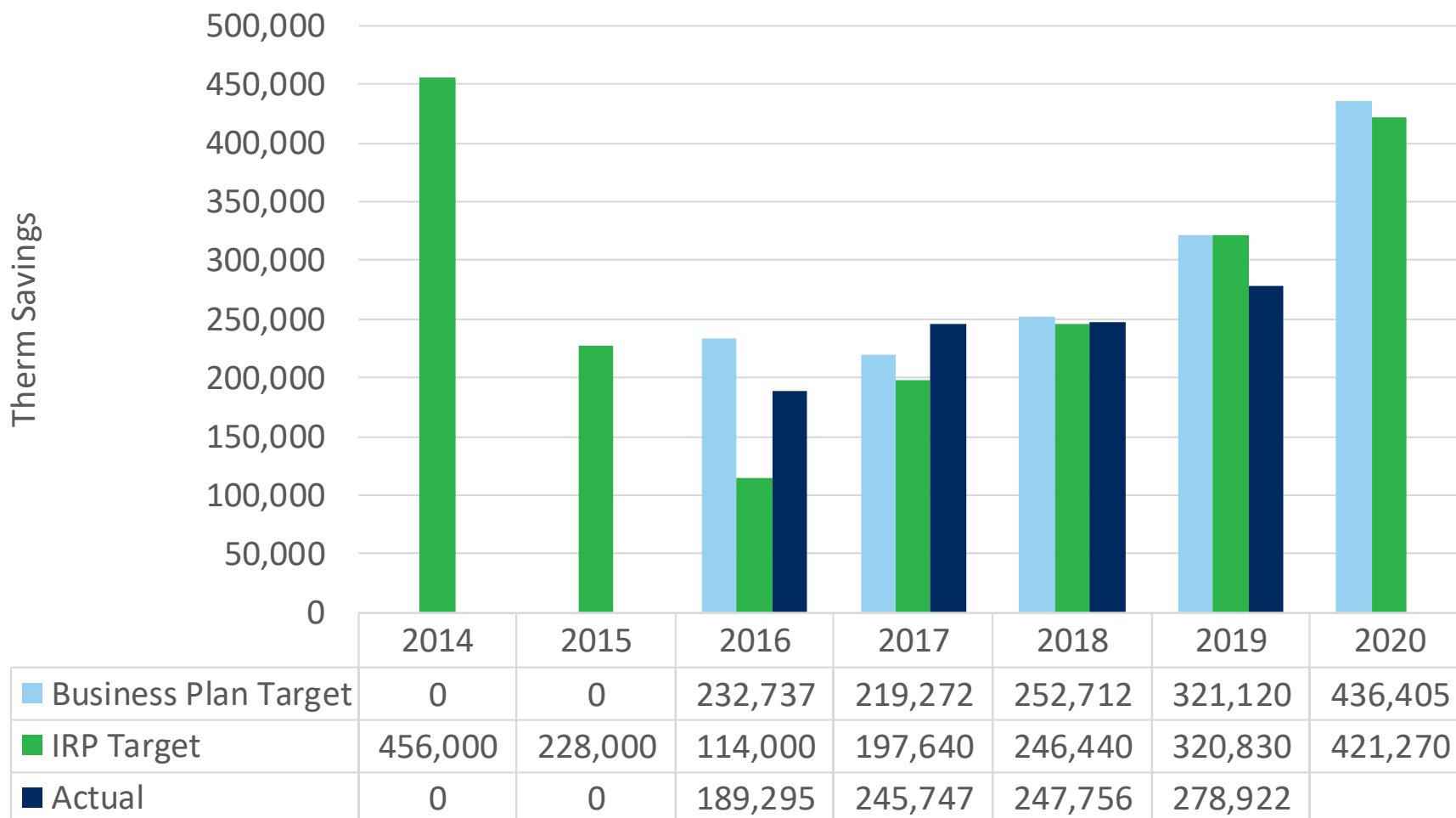

OR Energy Trust Gas Targets to Actual Savings

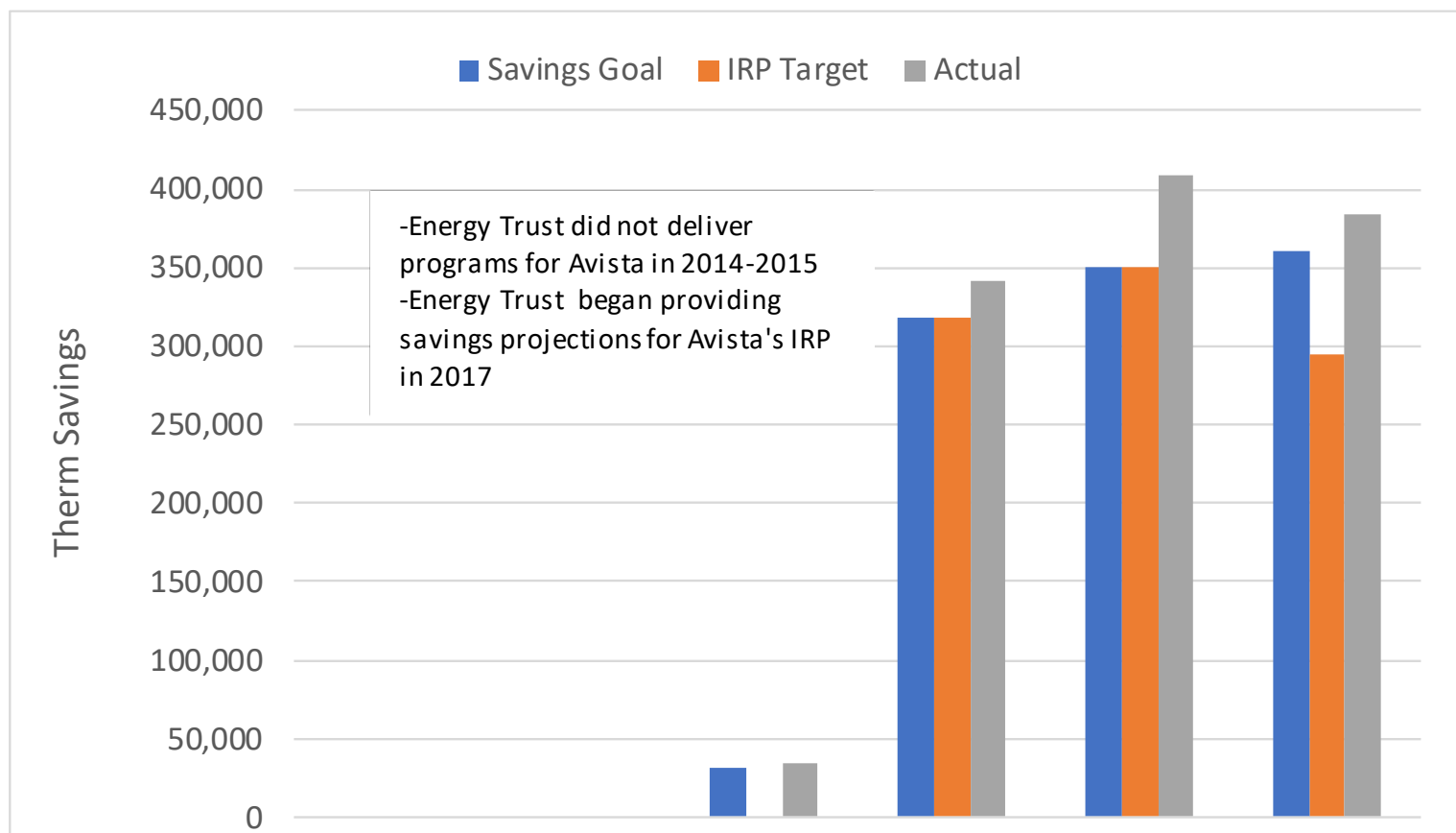

	2014	2015	2016	2017	2018	2019
Savings Goal			31,574	318,332	349,520	360,682
IRP Target				318,332	349,520	294,720
Actual			34,708	340,738	409,128	384,599



Energy Efficiency Business Planning



Conservation Potential Assessment (CPA)

- Primary Objectives
 - Meet legislative and regulatory requirements
 - Support integrated resource planning
 - Identify opportunities for savings; key measures in target segments
- Key Deliverables
 - 20-year conservation potential
 - Individual measures
 - IRP target

Conservation Potential Assessment

Technical Potential

- Theoretical upper limit of conservation
- All efficiency measures are phased in regardless of cost

Achievable Technical Potential

- Realistically achievable, accounting for adoption rates and how quickly programs can be implemented
- Does not consider cost-effectiveness of measures

Achievable Potential

- Includes economic screening of measures (cost effectiveness)
- Sets our conservation target

Business Planning Process

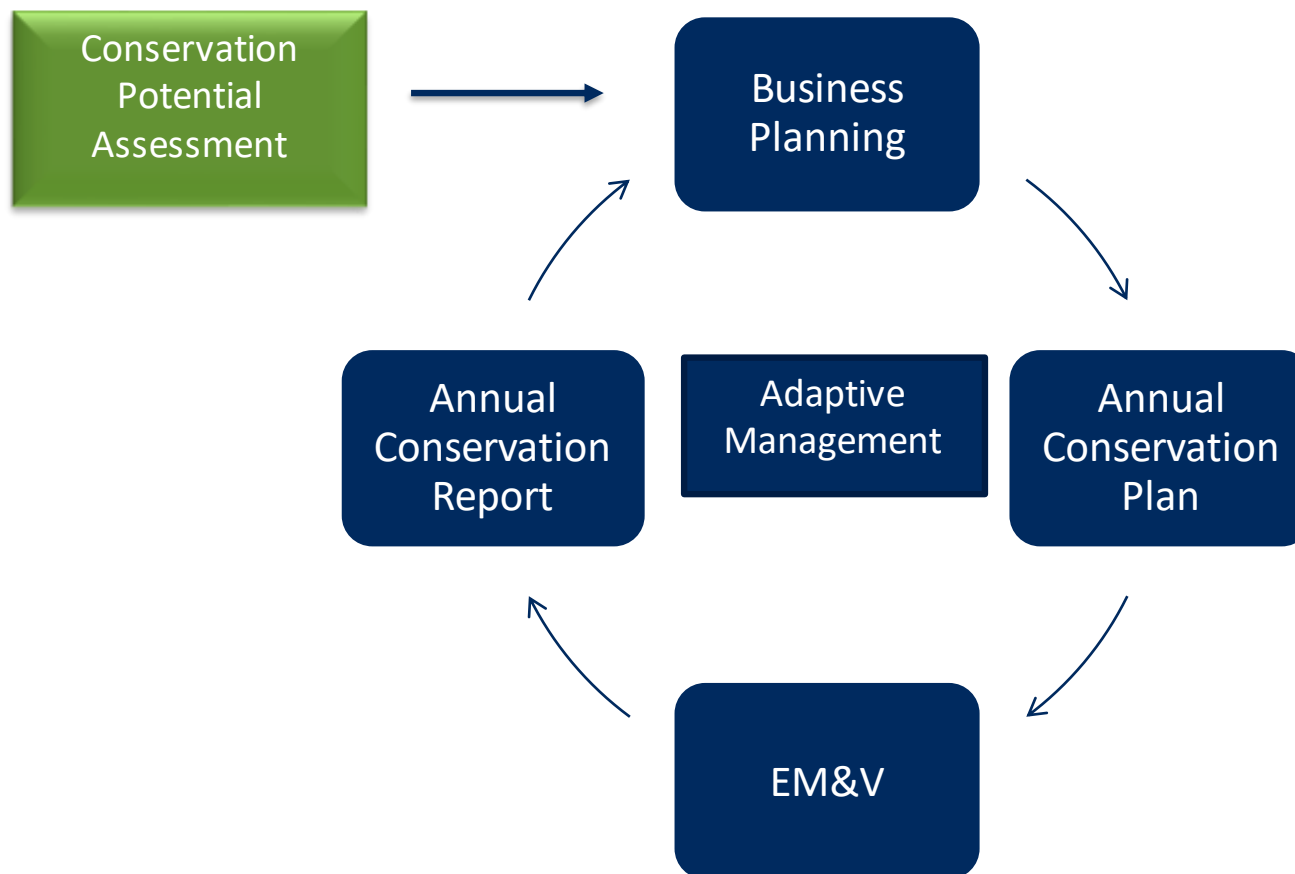

Business Planning Process

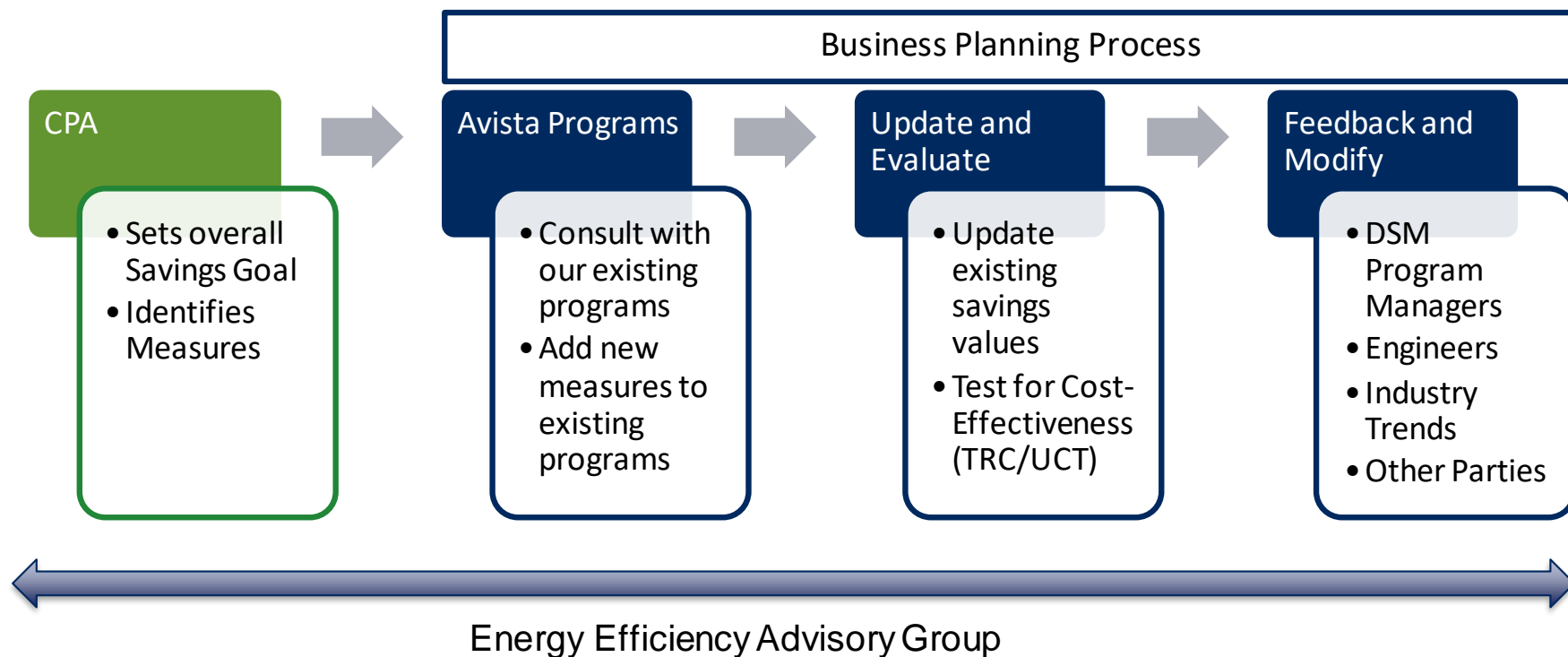

Incentive Setting

Cost-Effective Test

Utility Cost Test (UCT)
Total Resource Cost (TRC)

Must have a B/E ratio
of 1.0 or Higher

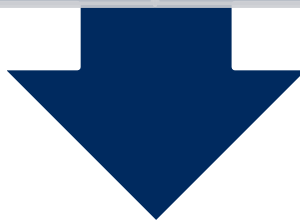

Decide Incentive Level

\$3 per
Therm

70% of
CIC

CE Impact

Portfolio
Alignment



Significant Costs and Benefits

COSTS

•Administration

(e.g., program design, development, operations, maintenance, overhead, customer service, marketing & outreach, sales, IT infrastructure, customer education, program evaluation, measurement & verification)

•Measure (Capital) Costs

(equipment costs incurred by the utility and participants)

•Incentives

•Revenue Loss

(bill reductions)

•Participant Costs

(Other than capital costs – value of service lost & transaction costs)

BENEFITS

•Avoided Costs

(complex)

•Tax Credits

(currently available for DG only)

•Market/Reliability Benefits

•Non-energy benefits

•Incentives

•Bill reductions

Energy Trust's Resource Assessment Model

- What is a resource assessment model?
 - Energy Trust's version of a Conservation Potential Assessment
 - Model that provides an estimate of energy efficiency resource potential achievable over a 20-year period
 - 'Bottom-up' approach to estimate potential starting at the measure level and scaling to a service territory
- Energy Trust uses a Model that calculates Technical, Achievable and Cost-Effective Achievable Energy Efficiency Potential
 - Final program/IRP targets are established via a deployment forecast in a separate tool
- We provide a 20-year energy efficiency forecast for utility IRPs about every two years.

Energy Trust's Resource Assessment Model is "Living Model"

- Energy Trust makes continuous improvements to the model
- Measures in the model are updated on an ongoing basis to reflect changing market conditions and savings estimates
- Emerging technologies are added to the model as data availability and product viability allows
- Cost-effective potential may be realized through programs, market transformation and/or codes and standards
- Under discussion: use of a "large project adder" to account for large, unexpected projects

Energy Trust Resource Assessment Model Inputs

Measure Level Inputs

Measure Definition and Application:

- Baseline/Efficient equip. definition
- Applicable customer segments
- Installation type (RET/ROB/NEW)*
- Measure Life

Measure Savings

Measure Cost

- Incremental cost for ROB/NEW measures
- Full cost for retrofit measures

Market Data (for scaling)

- Units per site
- Baseline/efficient equipment saturations
- Suitability

Utility 'Global' Inputs

Customer and Load Forecasts

- Used to scale measure level savings to a service territory
 - Residential Stocks: # of homes
 - Commercial Stocks: 1000s of Sq.Ft.
 - Industrial Stocks: Customer load

Avoided Costs

Customer Stock Demographics:

- Heating fuel splits
- Water heat fuel splits

* RET = Retrofit; ROB = Replace on Burnout; NEW = New Construction

Energy Trust 20-Year IRP EE Forecast Flow Chart

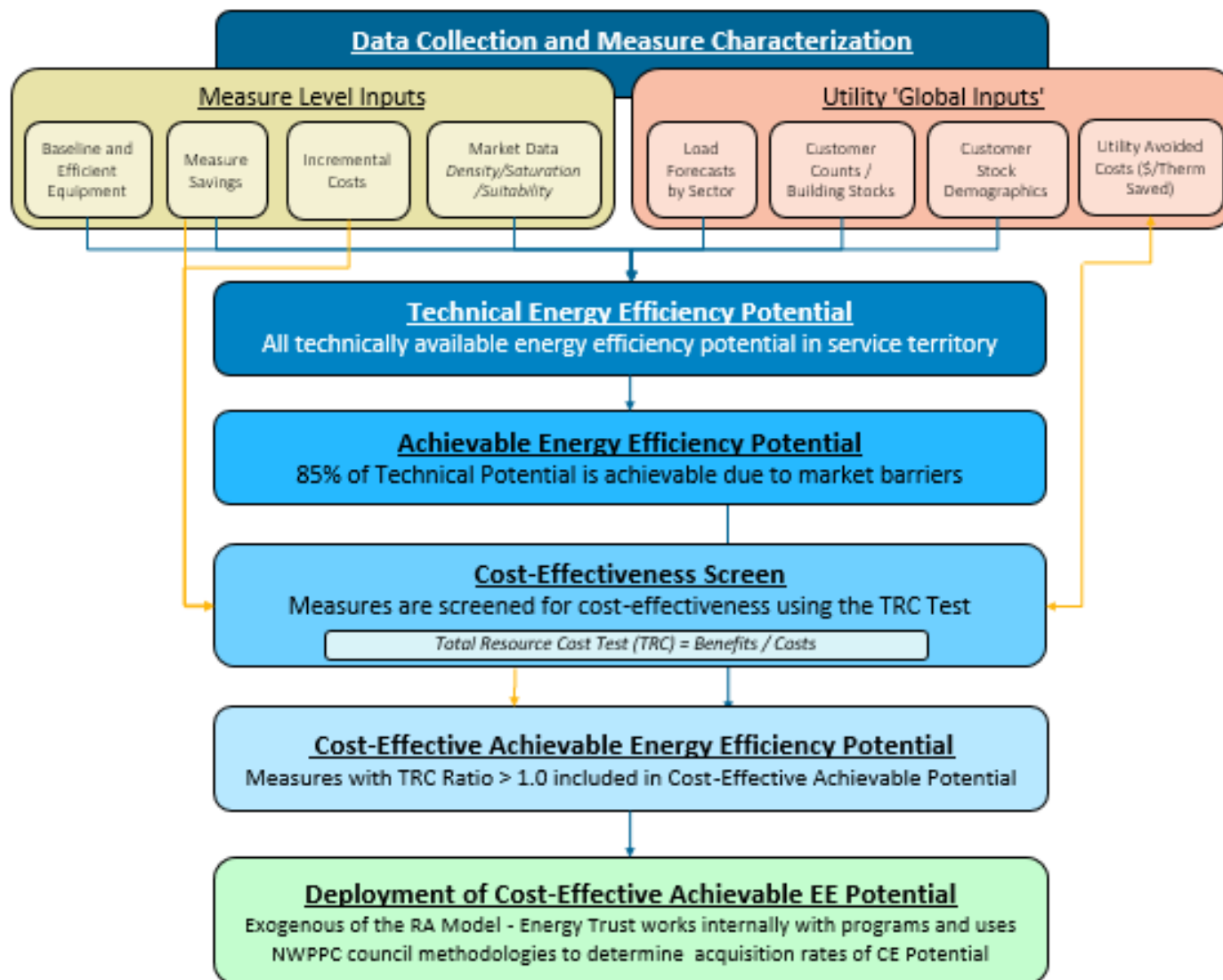

Energy Trust Forecasted Potential Types

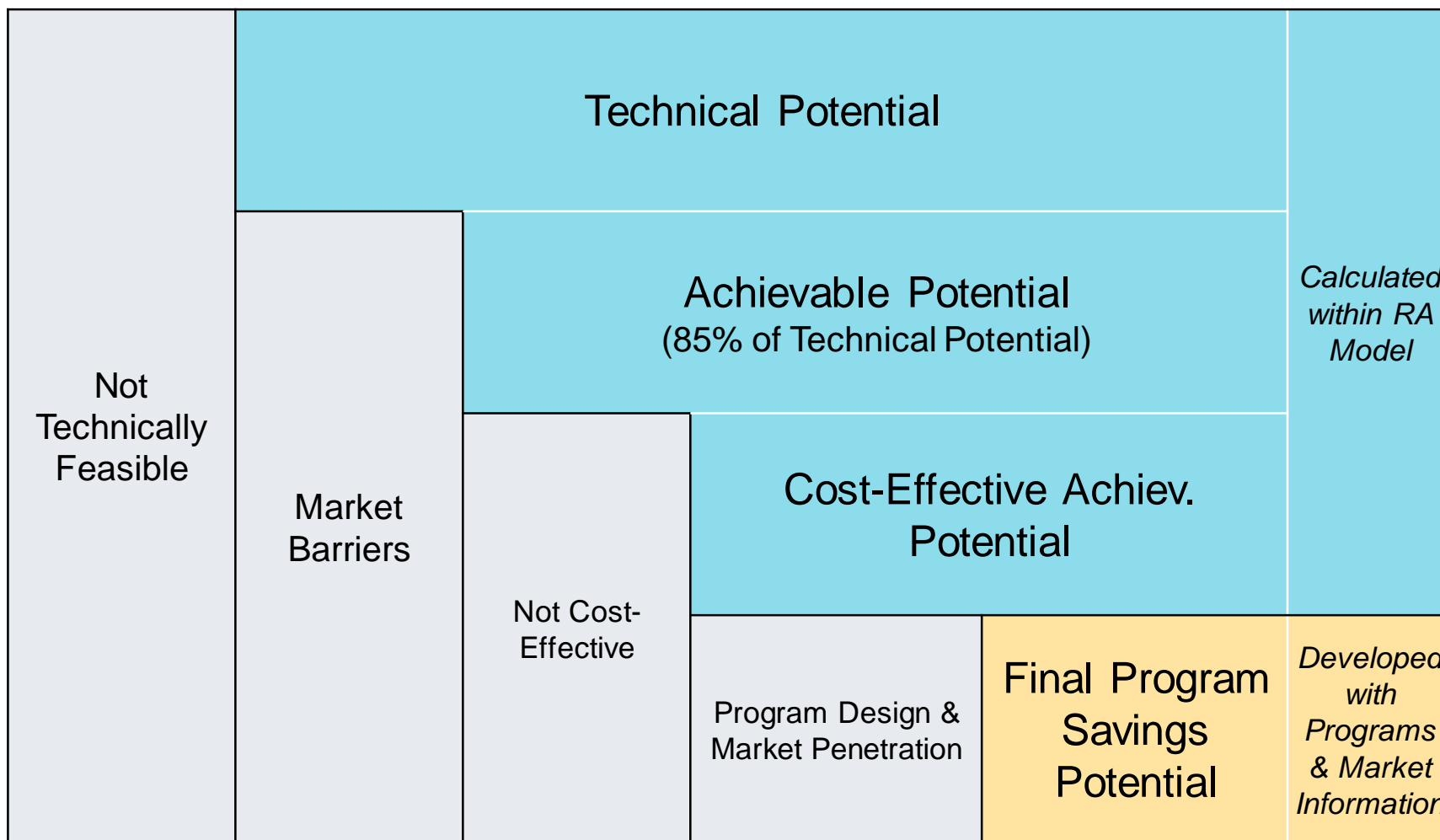

Energy Trust Cost-Effectiveness Screen For RA Modeling

- Energy Trust utilizes the Total Resource Cost (TRC) test to screen measures in the model for cost effectiveness

$$\text{TRC} = \frac{\text{Measure Benefits}}{\text{Total Measure Cost}}$$

- If TRC is > 1.0, it is cost-effective and the resources is included in cost-effective achievable potential
- Measure Benefits:
 - Avoided Costs
 - Annual measure savings x NPV avoided costs per therm or kWh
 - Quantifiable Non-Energy Benefits
 - Water savings, etc.
- Total Measure Costs:
 - The customer cost of installing an EE measure (full cost if retrofit, incremental over baseline if replacement)
- Some gas measures are forced into the model if they have exceptions from the OPUC under the criteria established via UM 551

Energy Trust Deployment

- The RA model results represent the maximum savings potential in a given year.
- Ramp rates are an estimate of how much of that available potential will come off Avista's system in a given year.
- Energy Trust ramp rates are based on NWPCC methods and ramp rates, but calibrated to be specific to Energy Trust.

Energy Trust Final Savings Projection Methodology

Energy Trust calibrates the first five years of energy efficiency acquisition ramp rates to program performance and budget goals.

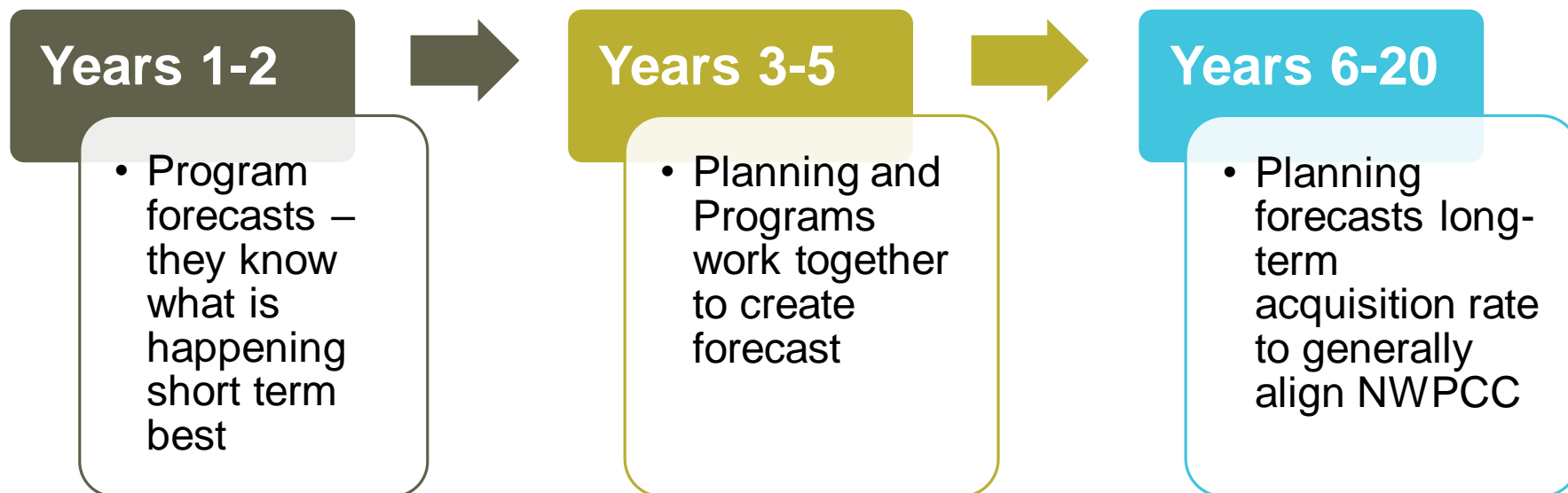

Energy Trust Ramp Rate Overview

- Total RA Model cost-effective potential is different depending on the measure type.
 - **Retrofit measure savings** are 100% of all potential in every year, therefore must be distributed in a curve that adds to 100% over the forecast timeframe (bell curve)
 - **Lost opportunity measure savings** are the savings available in that year only and deployment rates are what % of that available potential rate can be achieved – results in an s-curve
- Generally follows the NWPCC deployment methodology
 - 100% cumulative penetration for retrofit measures over 20-year forecast
 - 100% annual penetration for lost opportunity by end of 20-year forecast (program or code achieved)
 - Hard to reach measures or emerging technologies do not ramp to 100%

Energy Trust Ramp Rate Examples

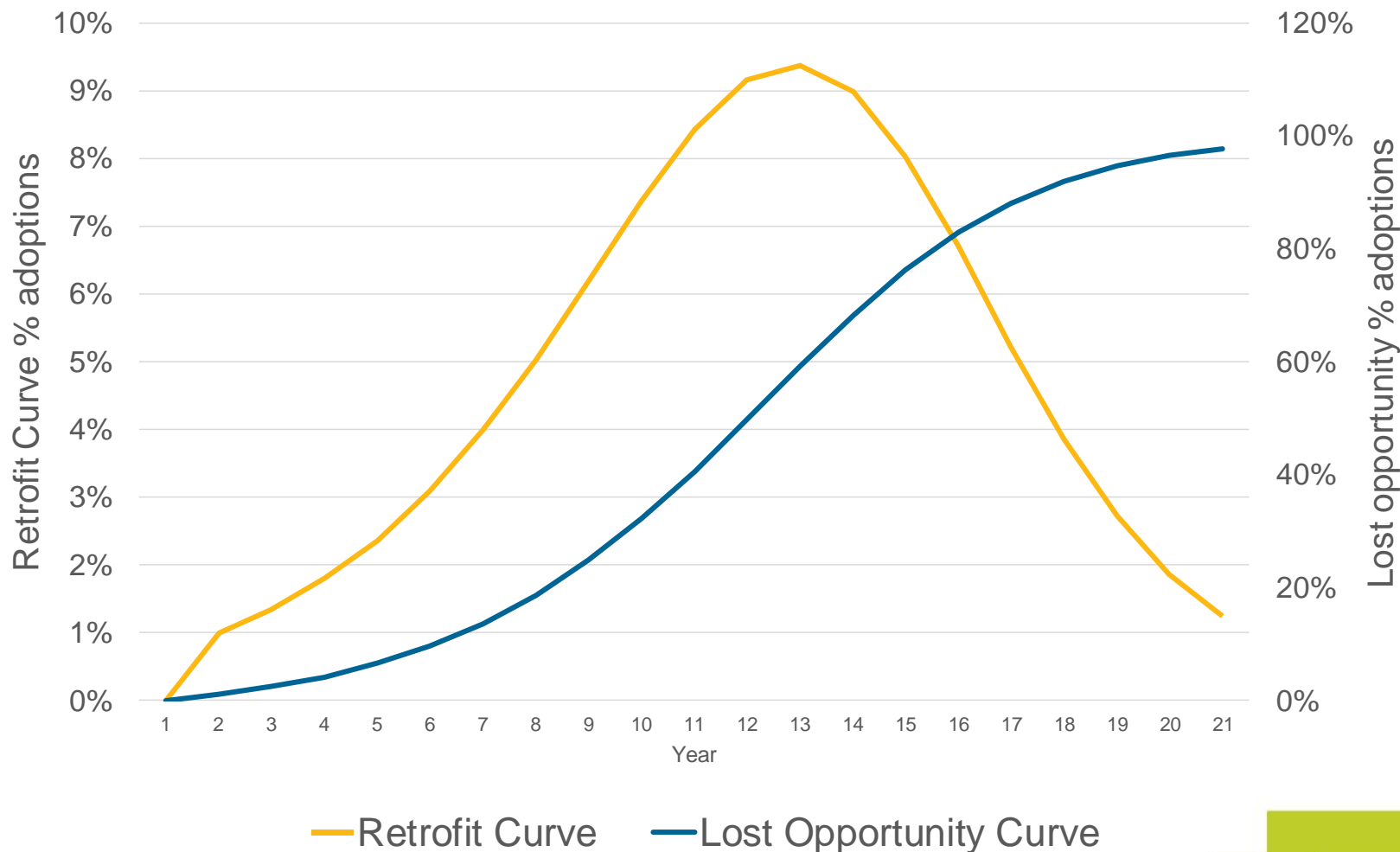

Avista's OR IRP Savings Targets Influence Annual Energy Trust Savings Goals and Budgets

- The savings forecasts that Avista incorporates into their IRPs is a reference point for setting annual Energy Trust savings goals and budgets
- Likewise, the Energy Trust savings goals from the last budget cycle inform the early years of the next IRP forecast
- This results in a cycle of iterative updates to savings projections based on the most recent market intelligence
- In addition, Energy Trust's measure development process uses the Utility Cost Test to screen measures for cost-effectiveness
 - This test sets an upper bound on the incentive that can be offered and this factors into the budget process

Questions?

2020 Natural Gas IRP schedule

- TAC 1: Wednesday, June 17, 2020:** TAC meeting expectations, 2020 IRP process and schedule, actions from 2018 IRP, and a Winter of 2018-2019 review. Procurement Plan and Resource Optimization benefits, Demand, Weather Analysis and a Weather Planning Standard, and an energy efficiency update.
- TAC 2: Thursday, August 6, 2020:** Market Analysis, Price Forecasts, Cost Of Carbon, demand forecasts and CPA results from AEG, Environmental Policies, fugitive emissions
- TAC 3: Wednesday, September 30, 2020:** Distribution, Avista's current supply-side resources overview, supply side resource options, renewable resources, overview of the major interstate pipelines and projects, and sensitivities and portfolio selection modeling.
- TAC 4: Wednesday, November 18, 2020:** Review assumptions and action items, final modeling results, portfolio risk analysis and 2020 Action Plan.
- TAC 5: February 2021:** TAC final review meeting (if necessary)



2021 Electric Integrated Resource Plan
Technical Advisory Committee Meeting No. 2 Agenda
Thursday, August 6, 2020
Virtual Meeting- 9:00 AM PST

Topic	Time	Staff
Introductions & IRP Process Updates	9:00	Lyons
Natural Gas & RNG Market Overview	9:30	Pardee
Break	10:45	
Natural Gas Price Forecast	11:00	Brutocao
Lunch	11:30	
Upstream Natural Gas Emissions	12:30	Pardee
Break	1:30	
Regional Energy Policy Update	1:45	Lyons
Natural Gas and Electric Coordinated Study	2:15	Gall/Pardee
Highly Impacted & Vulnerable Populations Baseline Analysis	3:00	Gall
Adjourn	3:45	



2021 Electric and Natural Gas IRPs TAC Introductions and IRP Process Updates

John Lyons, Ph.D.
Second Technical Advisory Committee Meeting
August 6, 2020

Updated Meeting Guidelines

- Gas and electric IRP teams working remotely, but still available by email and phone for questions and comments
- Some processes are taking longer remotely
- Virtual IRP meetings until back in the office and able to hold large group meetings
- TAC presentations, notes, work plans and past IRPs are posted on joint IRP page for gas and electric:
<https://www.myavista.com/about-us/integrated-resource-planning>

Virtual TAC Meeting Reminders

- Please mute mics unless speaking or asking a question
- Use the Skype chat box to write questions or comments or let us know you would like to say something
- Respect the pause
- Please try not to speak over the presenter or a speaker who is voicing a question or thought
- Remember to state your name before speaking for the note taker
- This is a public advisory meeting – presentations and comments will be recorded and documented

Integrated Resource Planning

- Required by Idaho, Oregon and Washington* every other year
- Guides resource strategy over the next twenty + years
- Current and projected load & resource position
- Resource strategies under different future policies
 - Resource choices
 - Conservation measures and programs
 - Transmission and distribution integration for electric
 - Gas distribution planning
 - Gas and electric market price forecasts
- Scenarios for uncertain future events and issues
- Key dates for modeling and IRP development are available in the Work Plans

Technical Advisory Committee

- The public process piece of the IRP – input on what to study, how to study, and review of assumptions and results
- Wide range of participants involved in all or parts of the process
 - Ask questions
 - Help with soliciting new members
- Open forum while balancing need to get through all of the topics
- Welcome requests for studies or different assumptions.
 - Time or resources may limit the number or type of studies
 - Earlier study requests allow us to be more accommodating
 - **August 1, 2020** was the electric study request deadline
- Planning teams are available by email or phone for questions or comments between the TAC meetings

2020 Electric IRP Meetings – IPUC

- AVU-E-19-01 <https://puc.idaho.gov/case/Details/3633>
- Telephonic public hearing on August 5, 2020
- August 19, 2020 comment deadline, September 2, 2020 response
- Overview of topics discussed at July 9, 2020 virtual public workshop:
 - Moving away from coal
 - Cost impacts for Idaho customers from Washington laws
 - IRP procedural questions about acknowledgment of the IRP
 - Climate change questions and timing of actions
 - Colstrip: decommissioning, other owners, cost sharing with Washington
 - Consideration of social costs/externalities and public health
 - Support for clean energy and Commission authority to require it
 - Resource timing
 - Risks considered in the IRP: economic, qualitative and climate
 - Idaho versus Montana wind locations
 - Maintaining Idaho RECs
 - Climate change law applicability and lawsuits

2021 Natural Gas IRP TAC Schedule

- TAC 1: Wednesday, June 17, 2020
- **TAC 2: Thursday, August 6, 2020 (Joint with Electric TAC)**
- TAC 3: Wednesday, September 30, 2020
- TAC 4: Wednesday, November 18, 2020
- TAC 5: February 2021 – TAC final review meeting if necessary
- Natural Gas TAC agendas, presentations and meeting minutes available at: <https://myavista.com/about-us/integrated-resource-planning>

2021 Electric IRP TAC Schedule

- TAC 1: Thursday, June 18, 2020
- **TAC 2: Thursday, August 6, 2020 (Joint with Natural Gas TAC)**
- Economic and Load Forecast, August 2020
- TAC 3: Tuesday, September 29, 2020
- TAC 4: Tuesday, November 17, 2020
- TAC 5: Thursday, January 21, 2021
- Public Outreach Meeting: February 2021
- TAC agendas, presentations and meeting minutes available at:
<https://myavista.com/about-us/integrated-resource-planning>

Process Updates

Economic and load forecast delay

- Special meeting 1:00 – 3:30 pm PST on Tuesday, August 18 or Wednesday, August 19, 2020 to cover the forecasts

AEG Conservation Potential Assessment and Demand Response Studies – delayed from TAC 2

- AEG has developed baseline assumptions, market profiles and energy/gas use per customer
- Market data has been collected and compiled
- Measure Assumption development is complete
- Compiled 2021 Power Plan Assumptions
- Measure List is in-process and is expected to be available mid-September
- CPA discussion with TAC – September TAC meeting.

Today's TAC Agenda

9:00 – Introductions & IRP Process Updates, Lyons

9:30 – Natural Gas & RNG Market Overview, Pardee

10:45 – Break

11:00 – Natural Gas Price Forecast, Brutocao

11:30 – Lunch

12:30 – Upstream Natural Gas Emissions, Pardee

1:30 – Break

1:45 – Regional Energy Policy Update, Lyons

2:15 – Natural Gas and Electric Coordinated Study, Gall/Pardee

3:00 – Highly Impacted & Vulnerable Populations Baseline
Analysis, Gall

3:45 – Adjourn



Natural Gas Market Overview

Tom Pardee, Natural Gas Planning Manager
Second Technical Advisory Committee Meeting
August 6, 2020

Units

Common Gas Units			
	1 Bcf	1 Dth	1 Therm
kWh	302,062,888	293.001	29.300
MWh	302,063	0.293	0.029

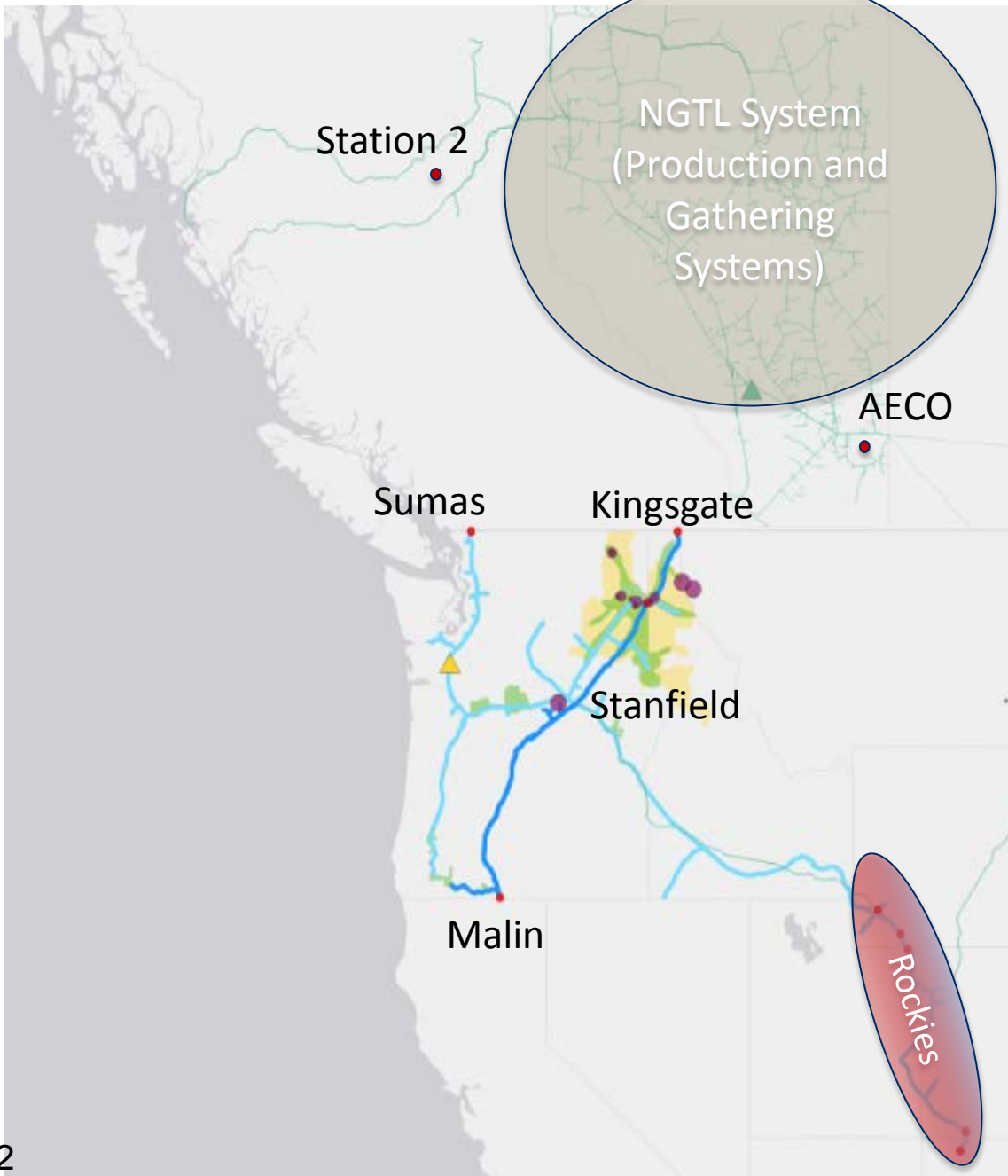

Avista Electric Territory

Avista Natural Gas Territory

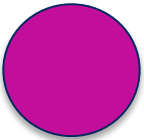

Electric Power Plants



Gas Transmission Network



Northwest Pipeline



Receipt Point



Jackson Prairie Storage (LDC Owned)

Avista's Supply

- Natural Gas LDC Side
 - 10% contracted from US supply basins
 - 90% contracted from Canadian supply basins
- Electric Side
 - 100% contracted from Canadian supply basins

US Demand

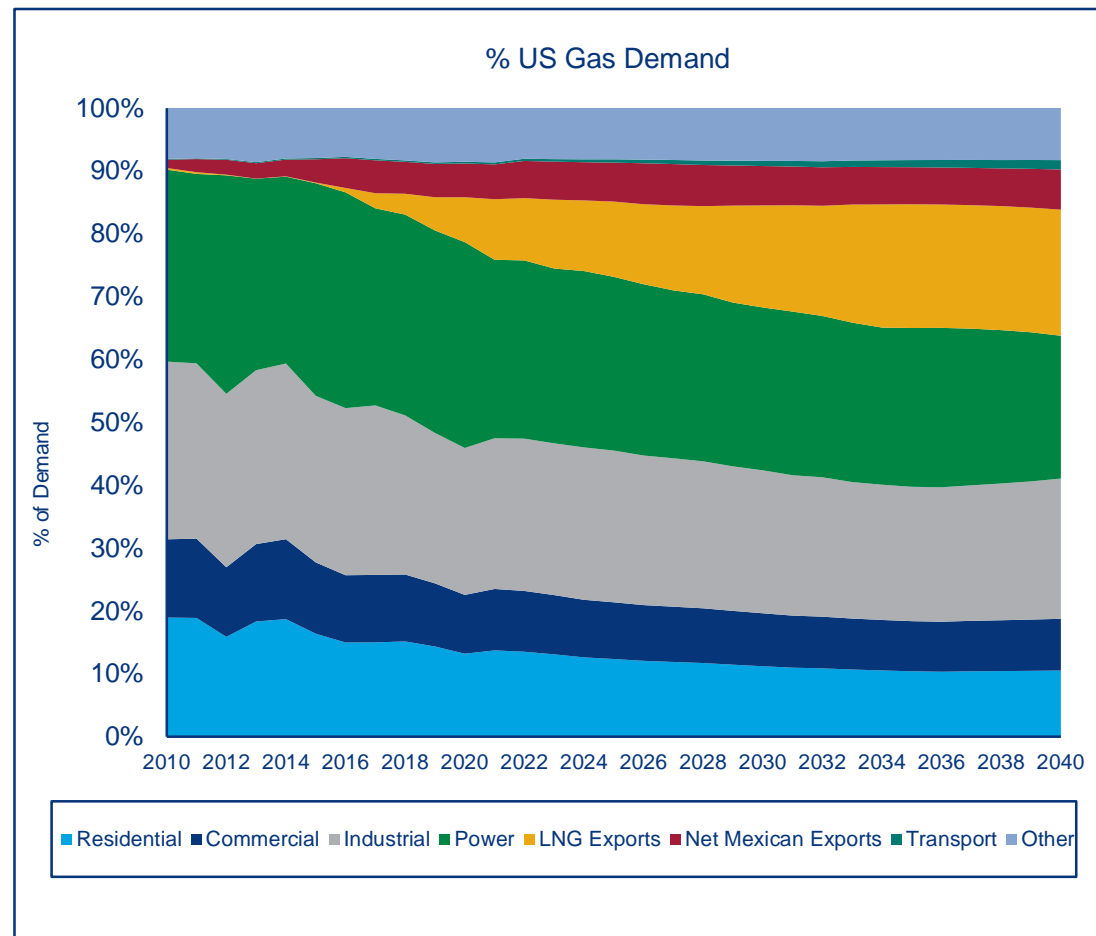
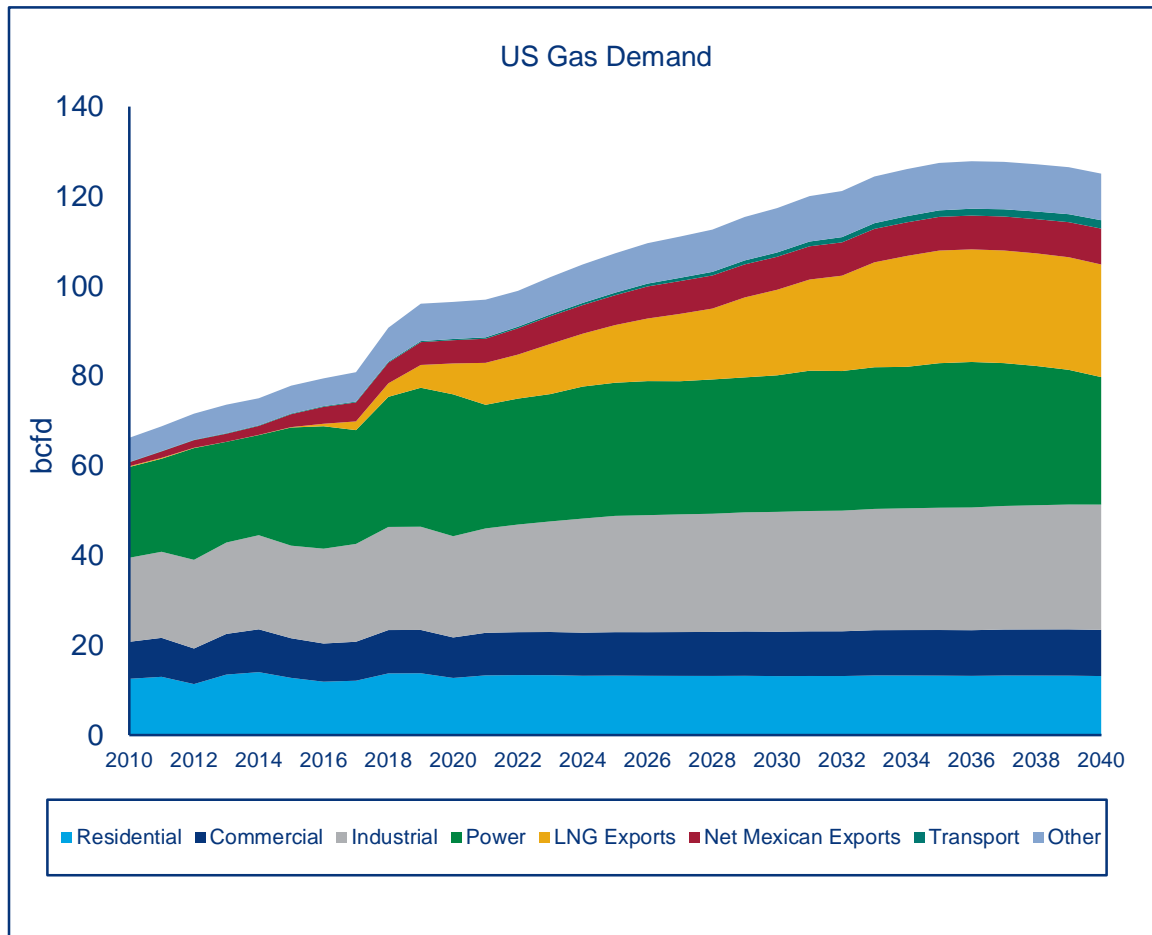

US Supply

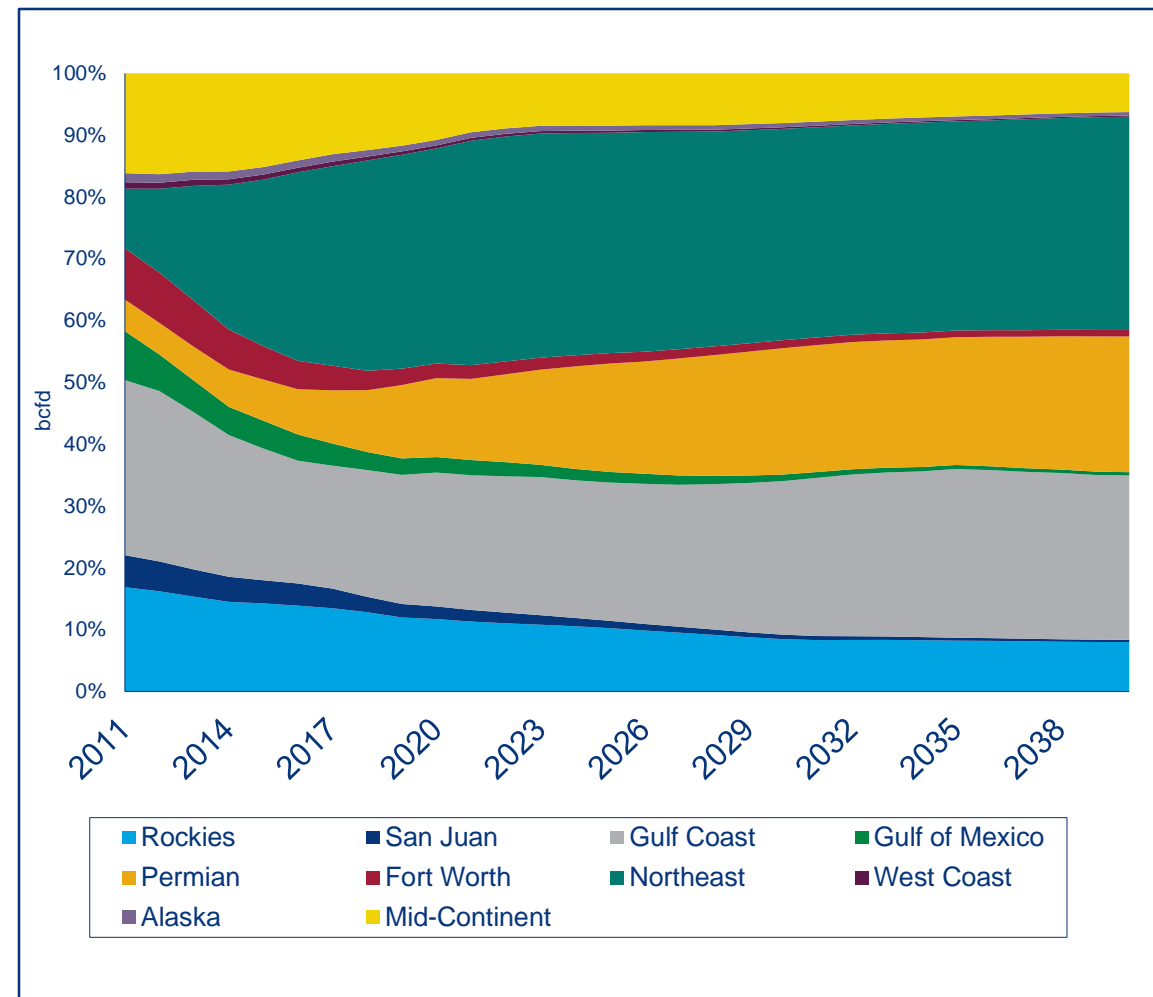
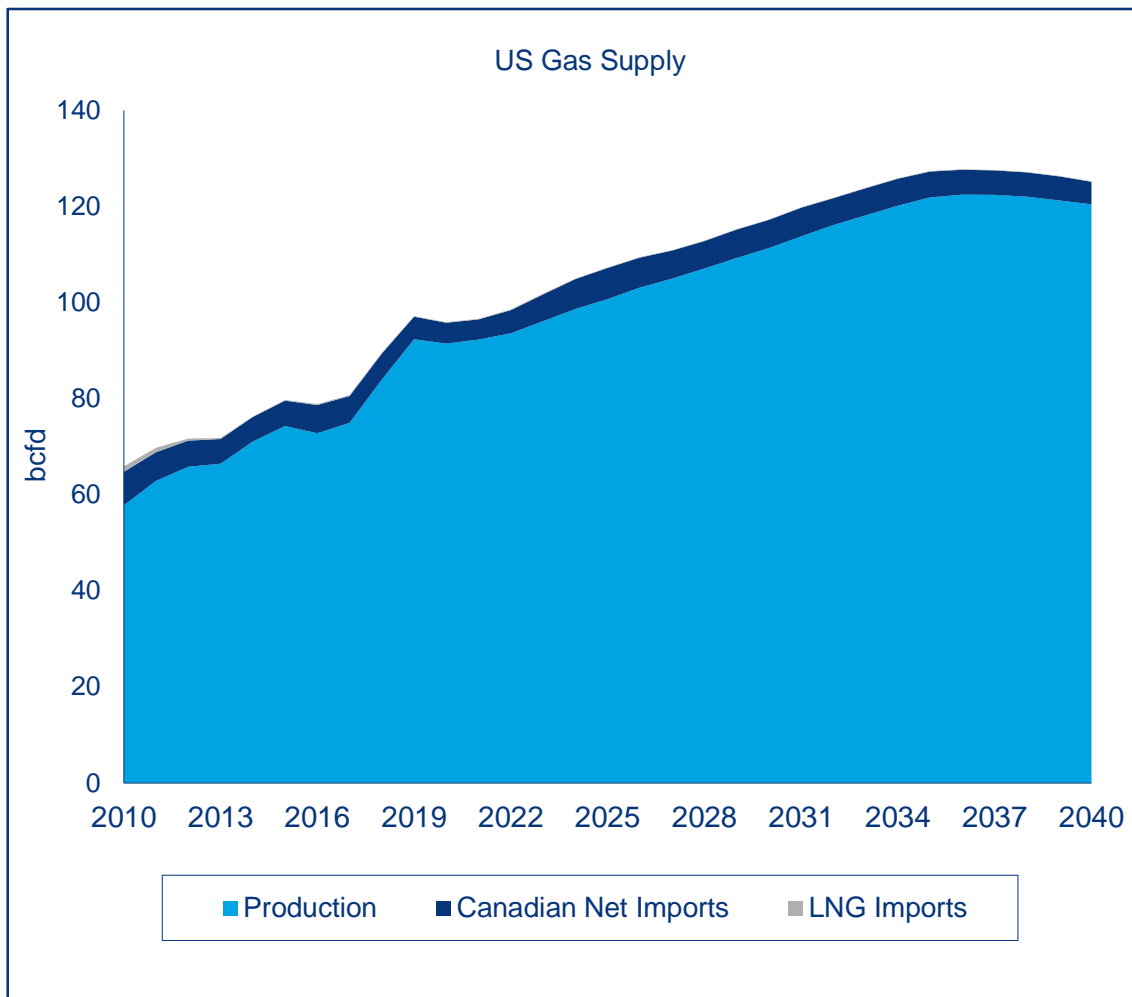

Canadian Supply and Demand

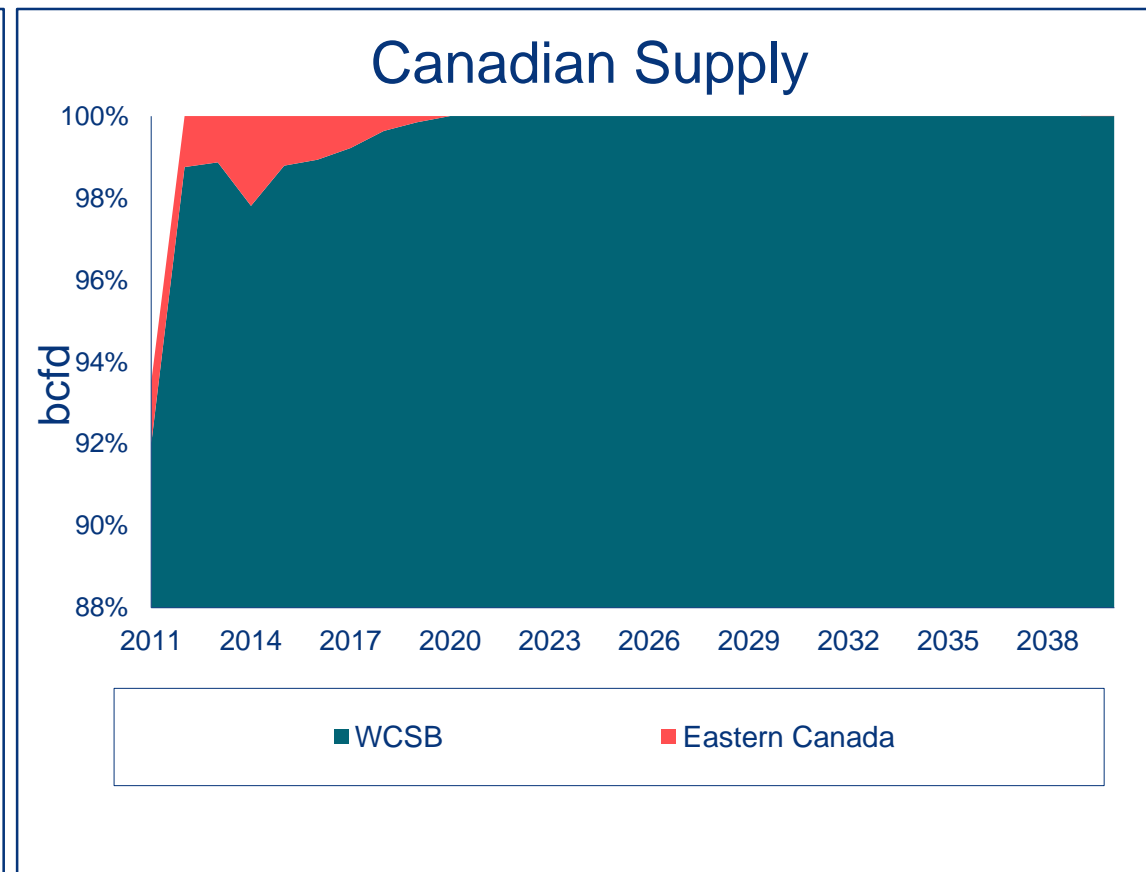
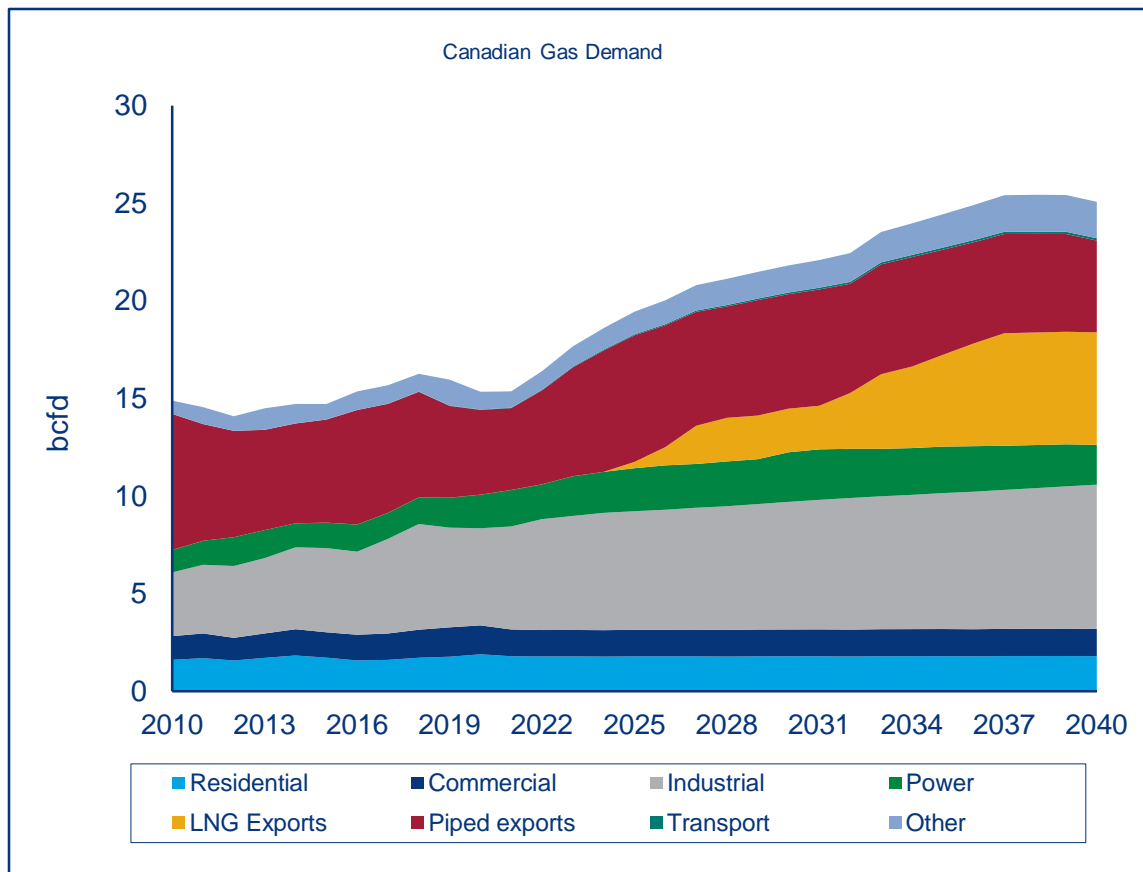



North American LNG Export Terminals

Approved, Not Yet Built

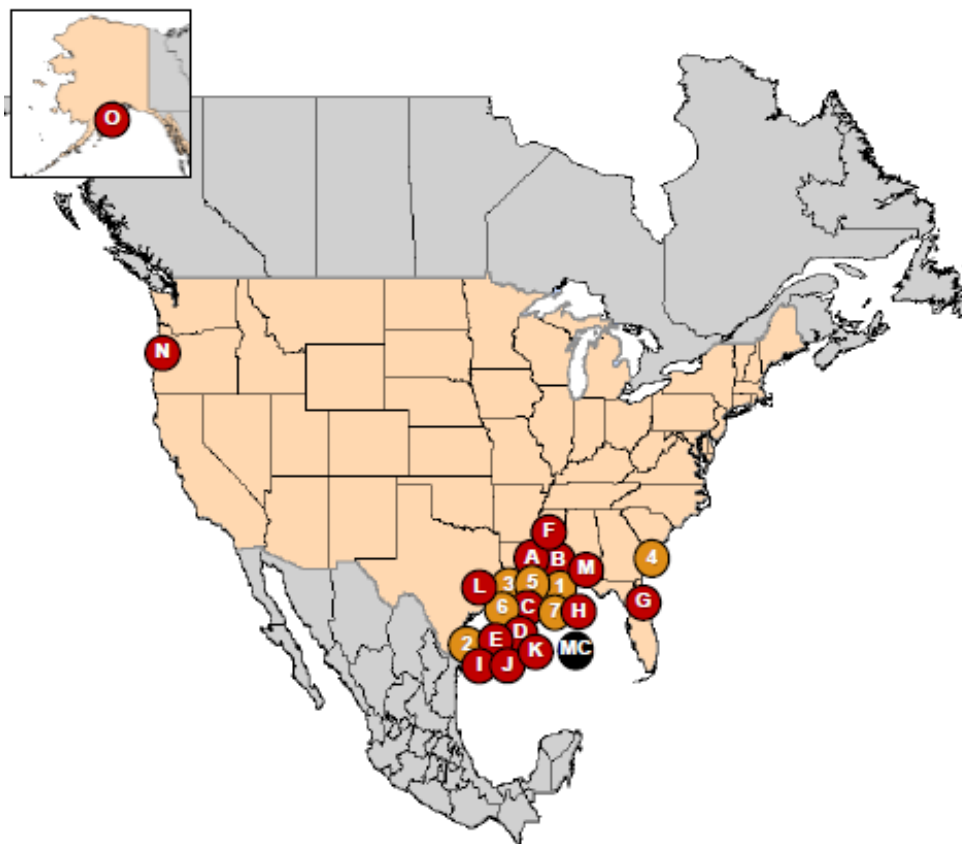

Export Terminals

UNITED STATES

APPROVED - UNDER CONSTRUCTION - FERC

1. Hackberry, LA: .71 Bcfd (Sempra-Cameron LNG Train 3) (CP13-25)
2. Corpus Christi, TX: 0.72 Bcfd (Cheniere-Corpus Christi LNG Train 2) (CP12-507)
3. Sabine Pass, LA: 0.7 Bcfd Train 6 (Sabine Pass Liquefaction) (CP13-552)
4. Elba Island, GA: 140 MMcfd (Southern LNG Company Units 7-10) (CP14-103)
5. Cameron Parish, LA: 1.41 Bcfd (Venture Global Calcasieu Pass) (CP15-550)
6. Sabine Pass, TX: 2.1 Bcfd (ExxonMobil - Golden Pass) (CP14-517)
7. Calcasieu Parish, LA: 4.0 Bcfd (Driftwood LNG) (CP17-117)

APPROVED - NOT UNDER CONSTRUCTION - FERC

- A. Lake Charles, LA: 2.2 Bcfd (Lake Charles LNG) (CP14-120)
- B. Lake Charles, LA: 1.08 Bcfd (Magnolia LNG) (CP14-347)
- C. Hackberry, LA: 1.41 Bcfd (Sempra - Cameron LNG Trains 4 & 5) (CP15-560)
- D. Port Arthur, TX: 1.86 Bcfd (Port Arthur LNG Trains 1 & 2) (CP17-20)
- E. Freeport, TX: 0.72 Bcfd (Freeport LNG Dev Train 4) (CP17-470)
- F. Pascagoula, MS: 1.5 Bcfd (Gulf LNG Liquefaction) (CP15-521)
- G. Jacksonville, FL: 0.132 Bcfd (Eagle LNG Partners) (CP17-41)
- H. Plaquemines Parish, LA: 3.40 Bcfd (Venture Global LNG) (CP17-66)
- I. Brownsville, TX: 0.55 Bcfd (Texas LNG Brownsville) (CP16-116)
- J. Brownsville, TX: 3.6 Bcfd (Rio Grande LNG - NextDecade) (CP16-454)
- K. Brownsville, TX: 0.9 Bcfd (Annova LNG Brownsville) (CP16-480)
- L. Corpus Christi, TX: 1.86 Bcfd (Cheniere Corpus Christi LNG) (CP18-512)
- M. Sabine Pass, LA: NA Bcfd (Sabine Pass Liquefaction) (CP19-11)
- N. Coos Bay, OR: 1.08 Bcfd (Jordan Cove) (CP17-494)
- O. Nikiski, AK: 2.63 Bcfd (Alaska Gasline) (CP17-178)

APPROVED - NOT UNDER CONSTRUCTION - MARAD/Coast Guard

- MC. Gulf of Mexico: 1.8 Bcfd (Delfin LNG)

CANADA

For Canadian LNG Import and Proposed Export Facilities:

<https://www.nrcan.gc.ca/energy/natural-gas/5683>

As of May 29, 2020



North American LNG Exports

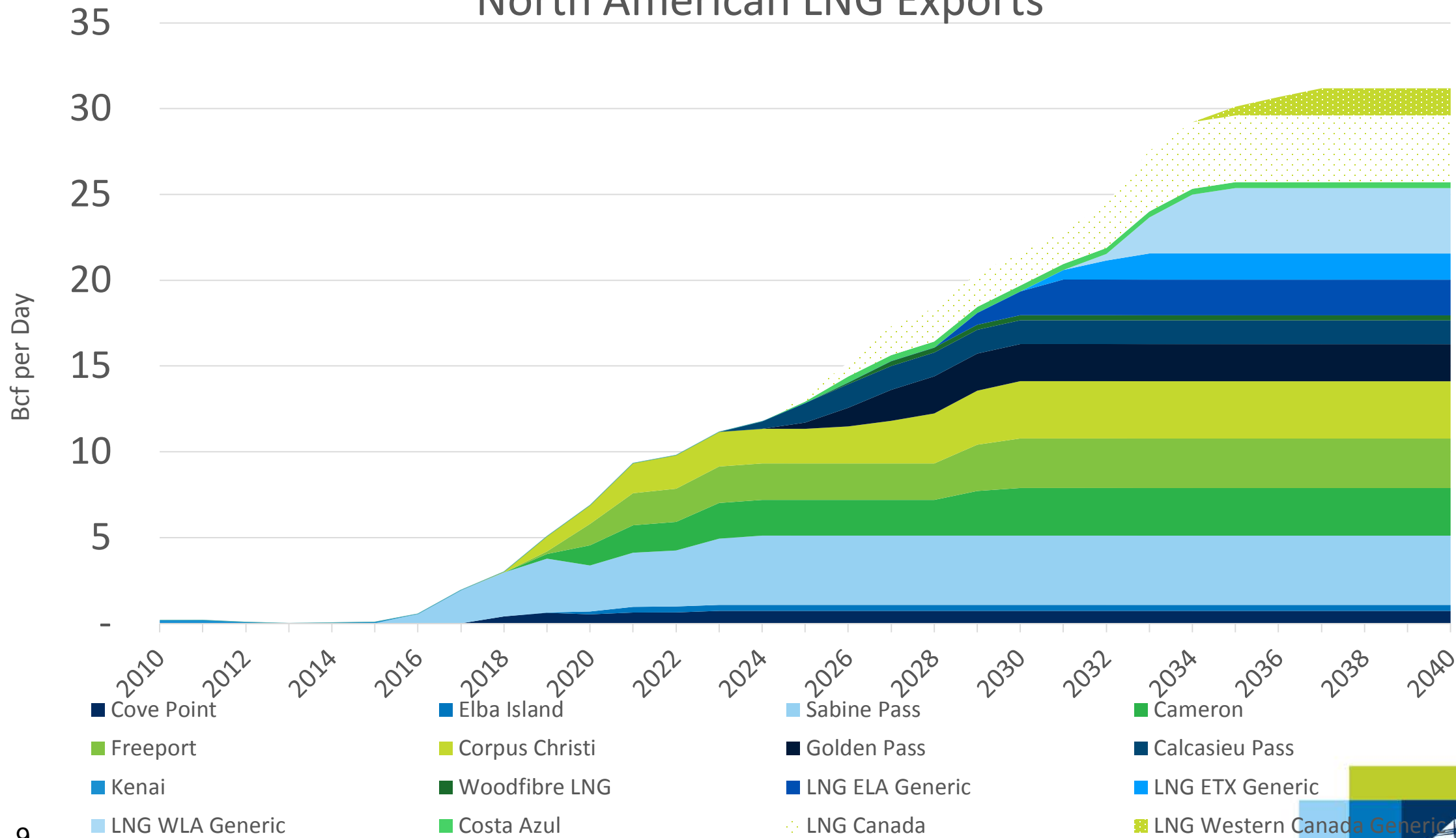

West

Total Demand by Census Region

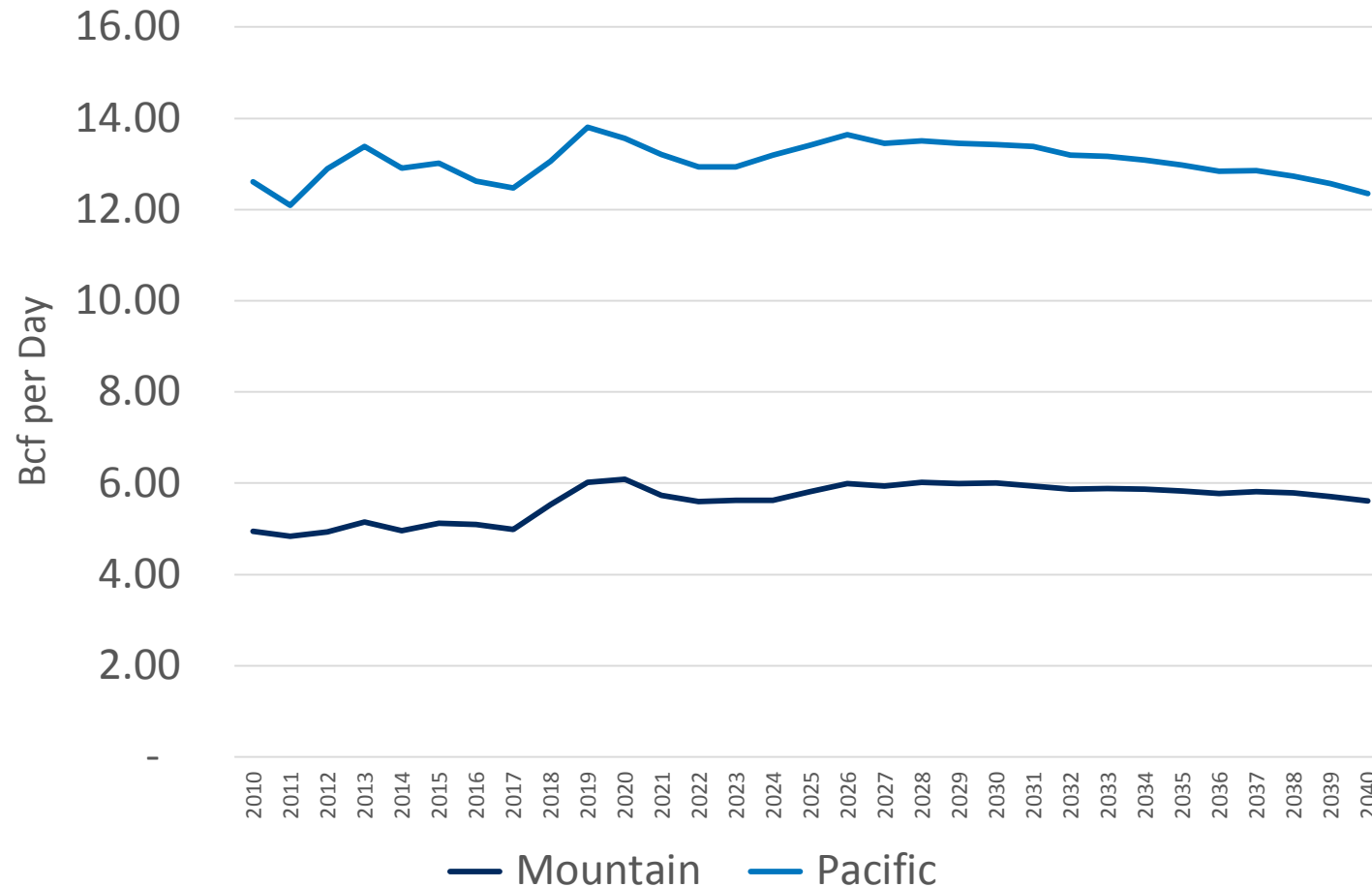

Census Region Map

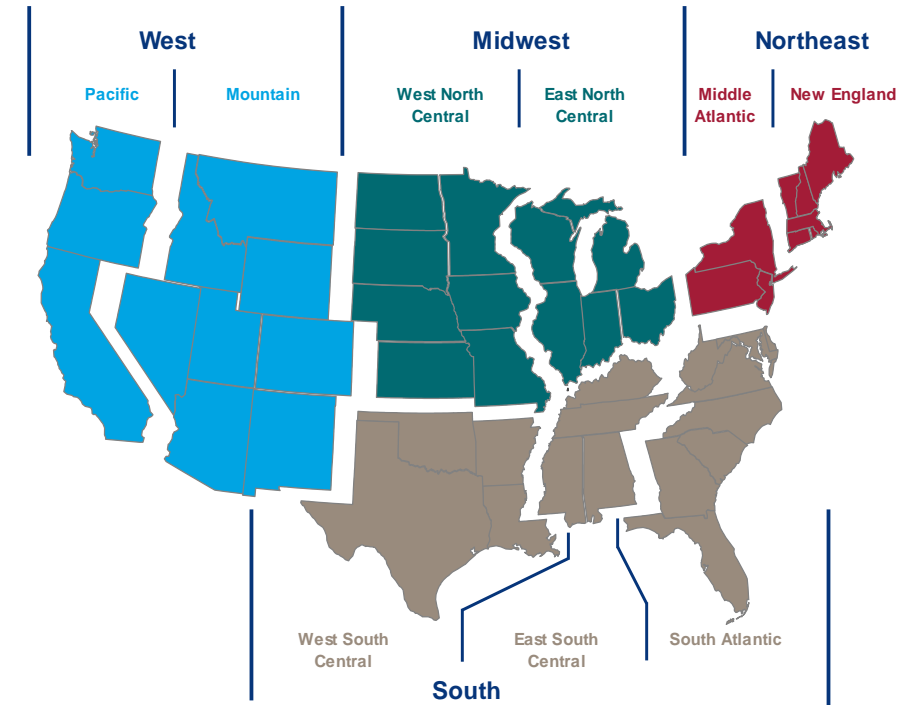

Note: Pacific does not include Alaska or Hawaii

Power Generation and Transport demand

Transport

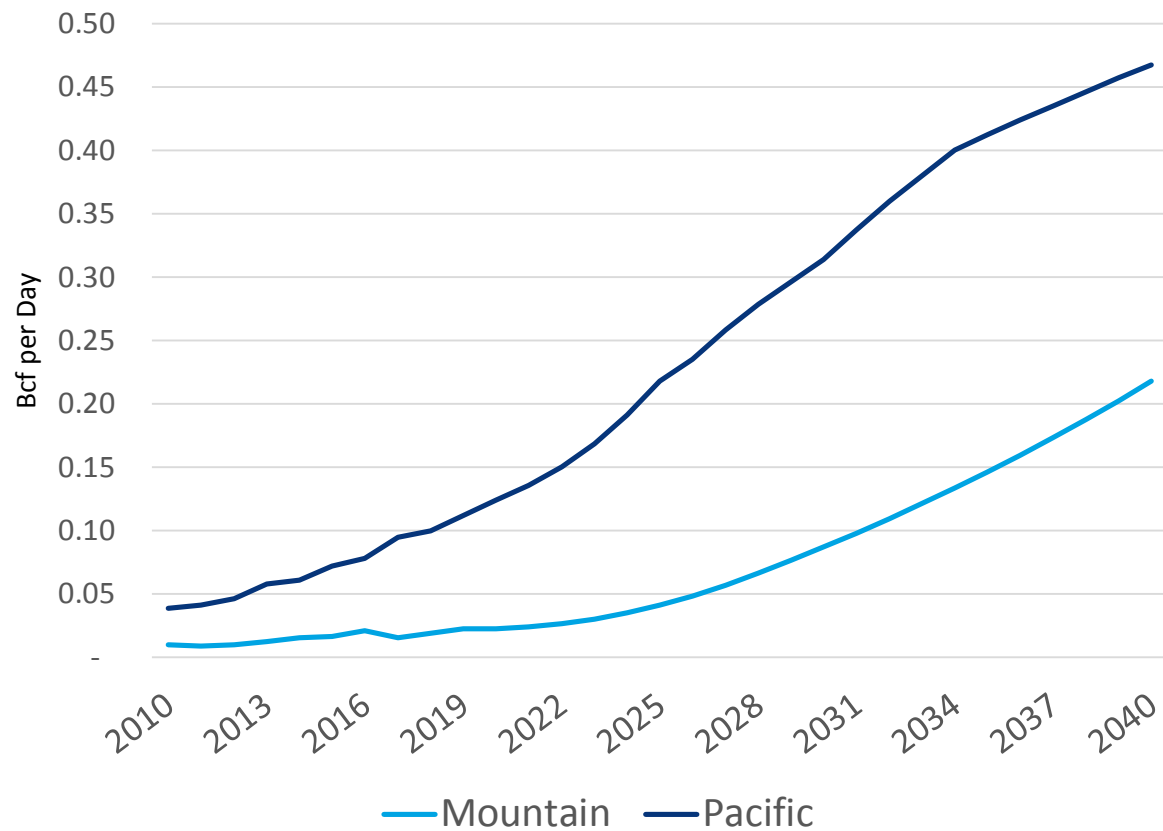

Power Generation

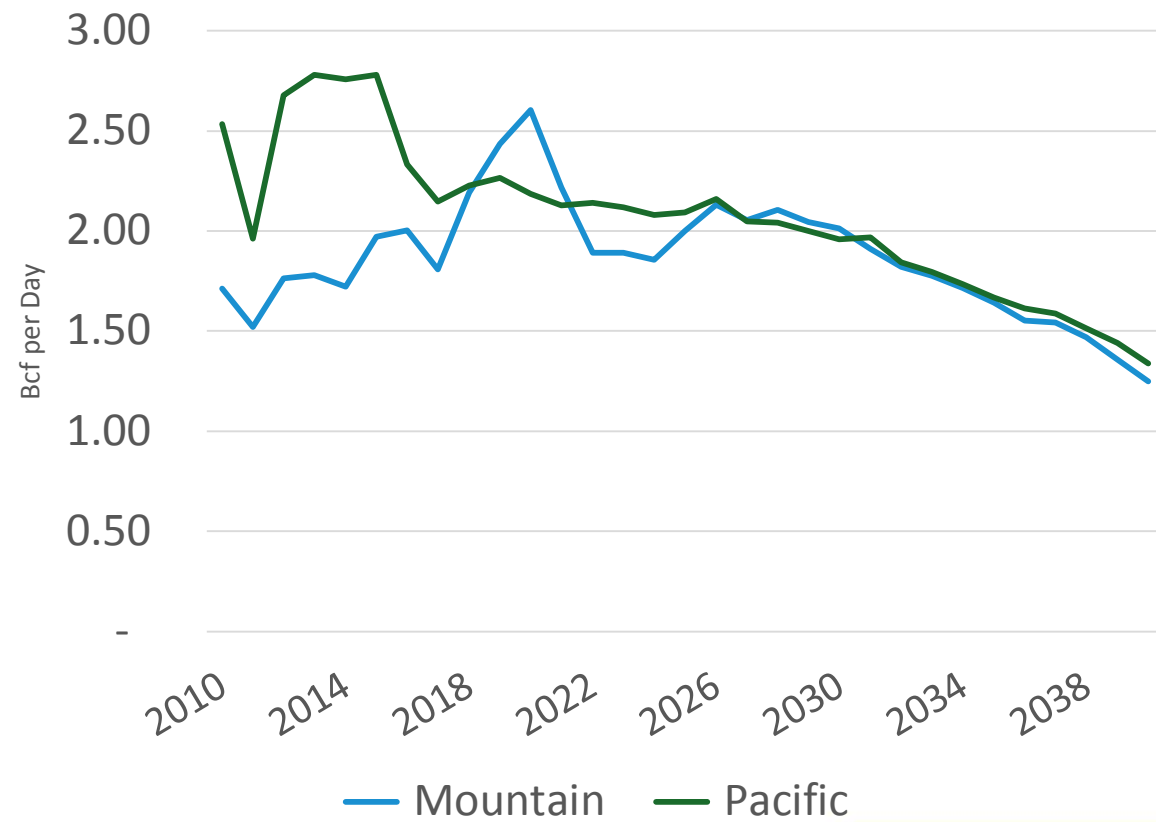

West demand of Res-Com-Ind

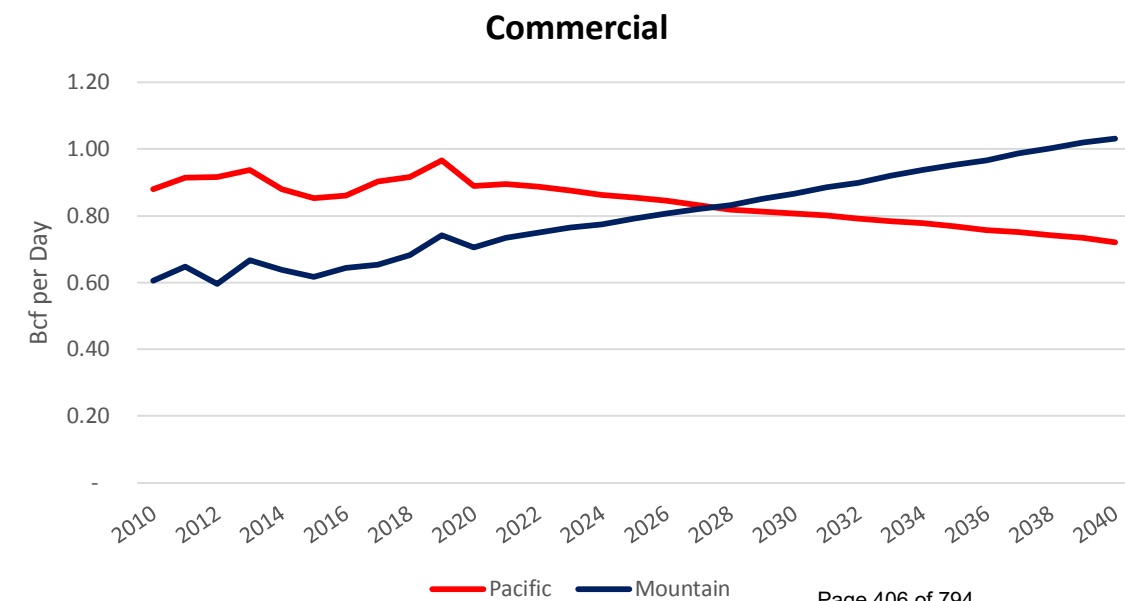
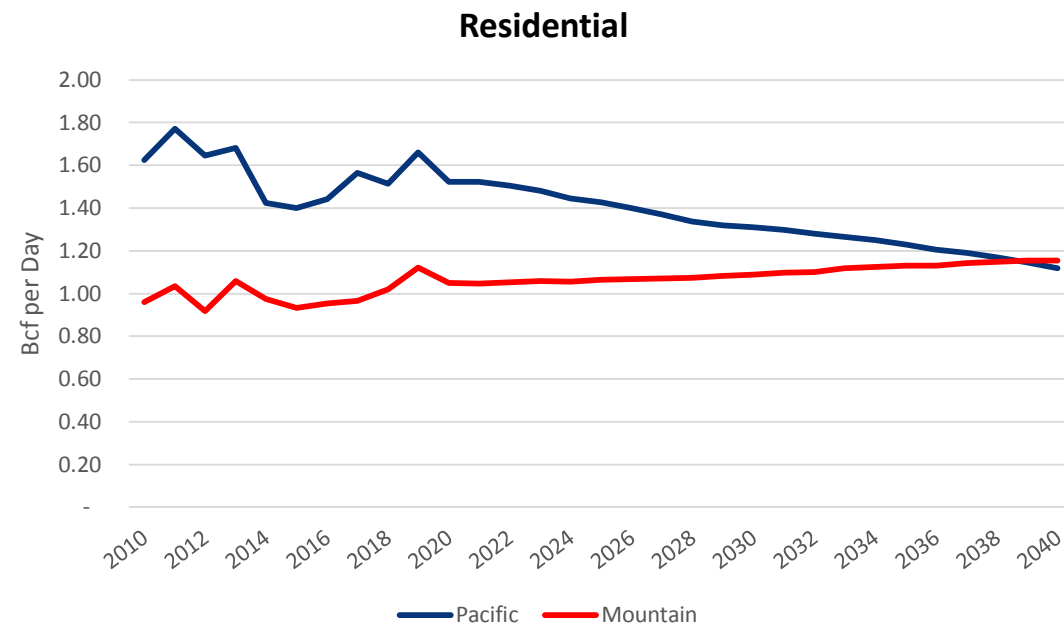
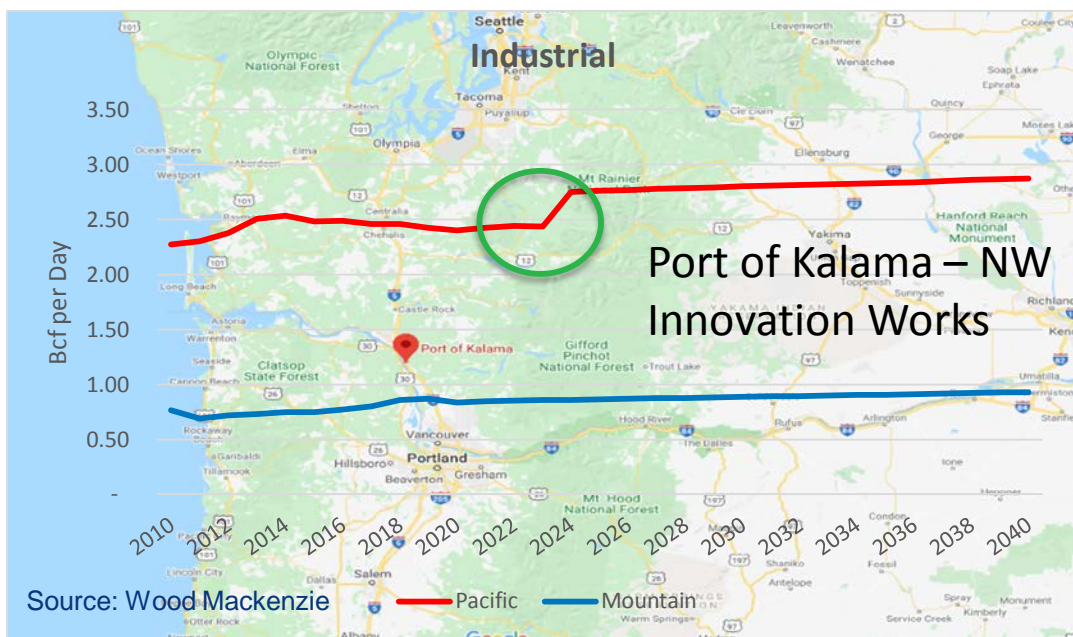

Wood Mackenzie Disclaimer

- The foregoing [chart/graph/table/information] was obtained from the [North America Gas Service]TM, a product of Wood Mackenzie.”
- Any information disclosed pursuant to this agreement shall further include the following disclaimer: "The data and information provided by Wood Mackenzie should not be interpreted as advice and
- you should not rely on it for any purpose. You may not copy or use this data and information except as expressly permitted by Wood Mackenzie in writing. To the fullest extent permitted by law,
- Wood Mackenzie accepts no responsibility for your use of this data and information except as specified in a written agreement you have entered into with Wood Mackenzie for the provision of such of such data and information

Us Natural Gas Storage

Region	Stocks billion cubic feet (Bcf)				Historical Comparisons			
	07/24/20	07/17/20	net change	implied flow	Year ago (07/24/19)		5-year average (2015-19)	
					Bcf	% change	Bcf	% change
East	706	693	13	13	591	19.5	626	12.8
Midwest	815	799	16	16	669	21.8	687	18.6
Mountain	196	190	6	6	155	26.5	176	11.4
Pacific	313	311	2	2	270	15.9	295	6.1
South Central	1,211	1,221	-10	-10	930	30.2	1,028	17.8
Salt	339	349	-10	-10	227	49.3	274	23.7
Nonsalt	872	872	0	0	703	24.0	754	15.6
Total	3,241	3,215	26	26	2,615	23.9	2,812	15.3

Totals may not equal sum of components because of independent rounding.

Working gas in underground storage compared with the 5-year maximum and minimum

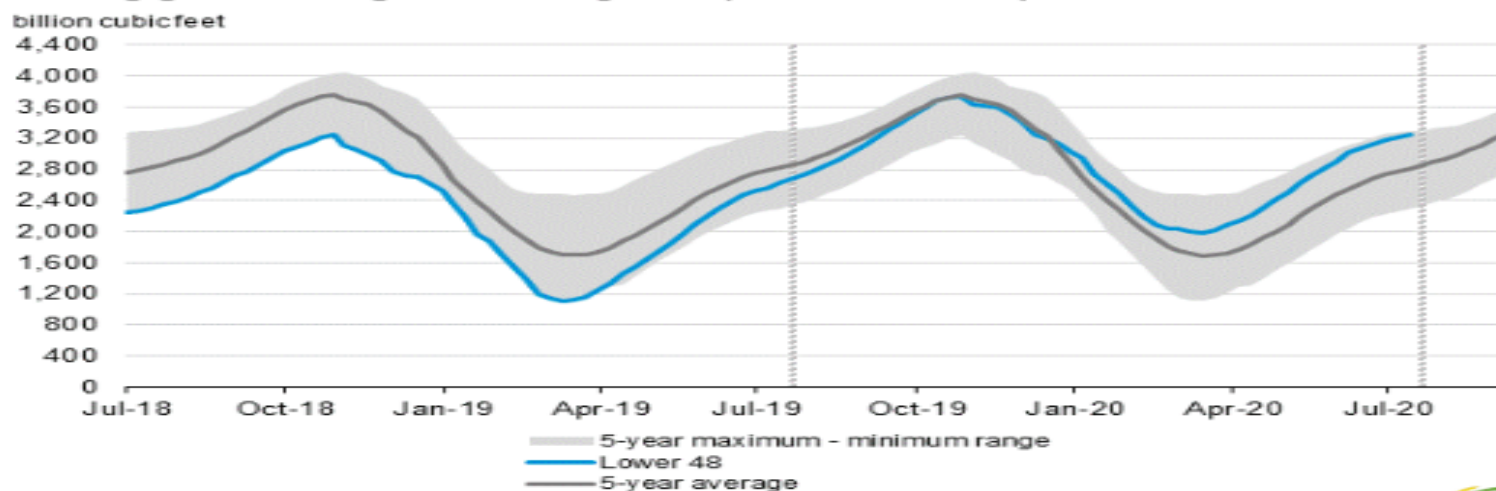

Source: U.S. Energy Information Administration



Rig Counts

Area	Last Count	Count	Change from Prior Count	Date of Prior Count	Change from Last Year	Date of Last Year's Count
U.S.	24 July 2020	251	-2	17 July 2020	-695	26 July 2019
Canada	24 July 2020	42	+10	17 July 2020	-85	26 July 2019
International	June 2020	781	-24	May 2020	-357	June 2019

US Rig Count History

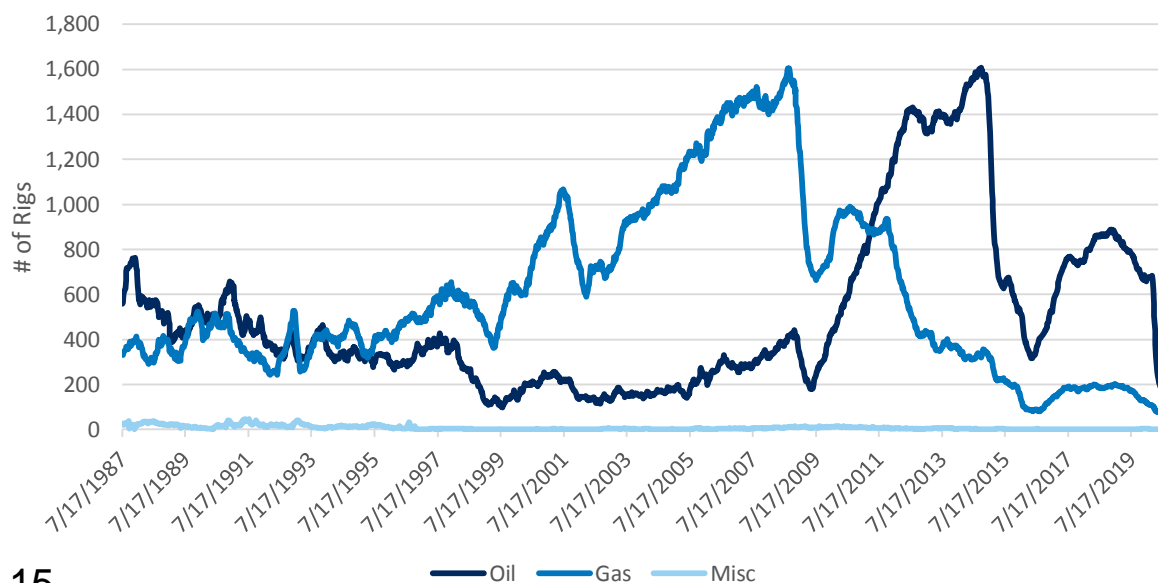

Canadian Rig Count History

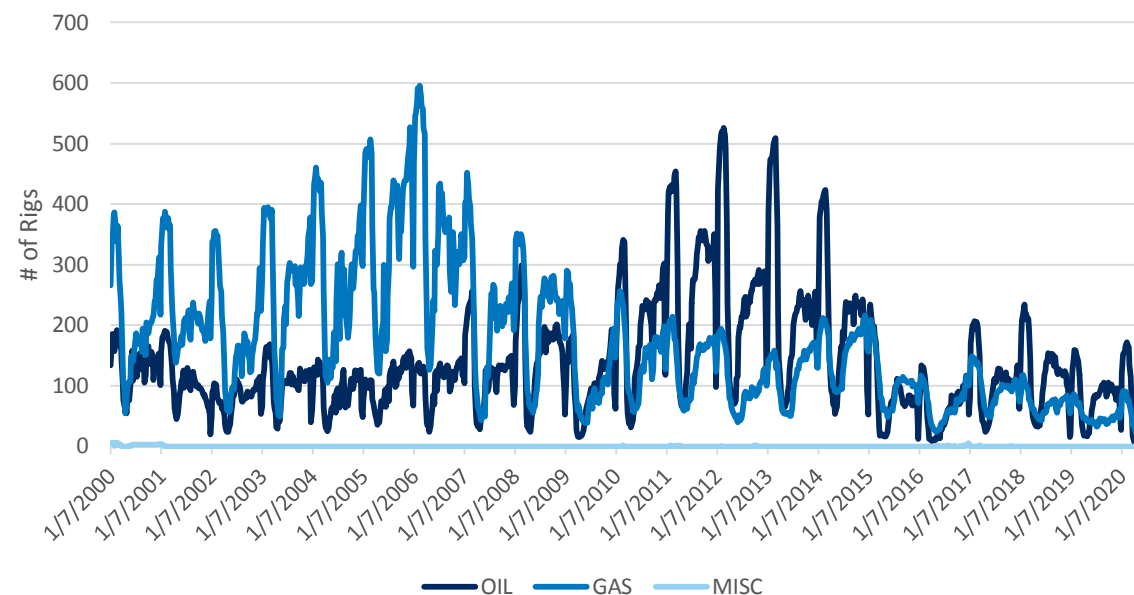

Production and Drilling efficiency

Oil production
thousand barrels/day

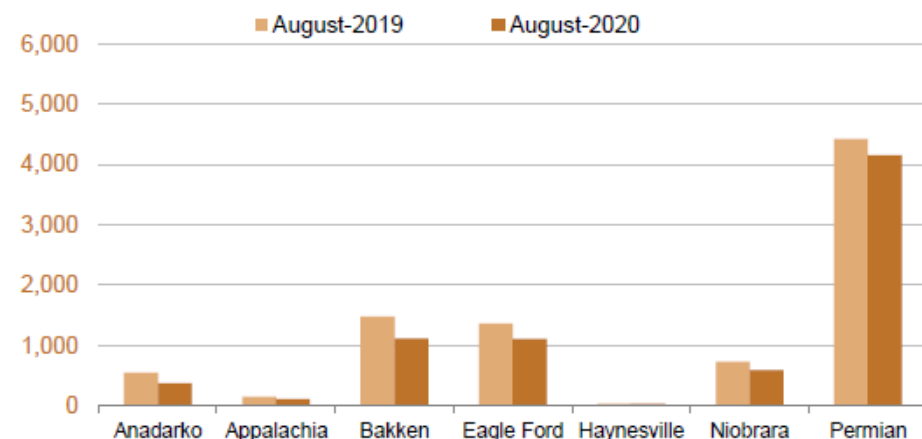

Natural gas production
million cubic feet/day

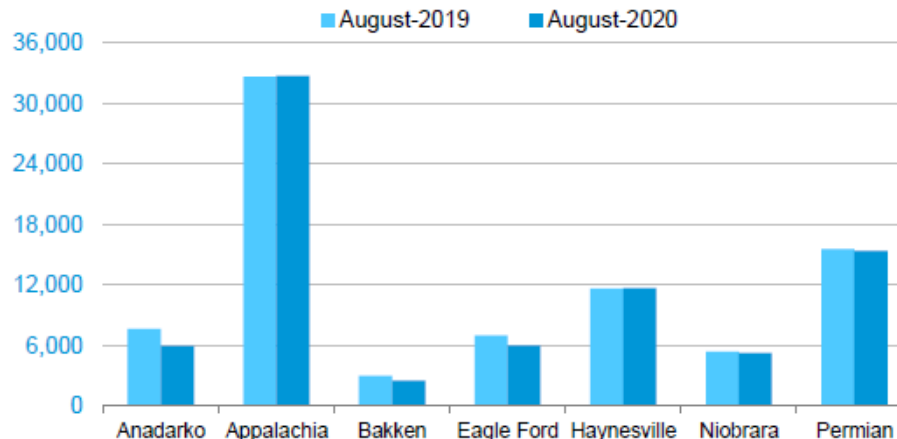

New-well oil production per rig
barrels/day

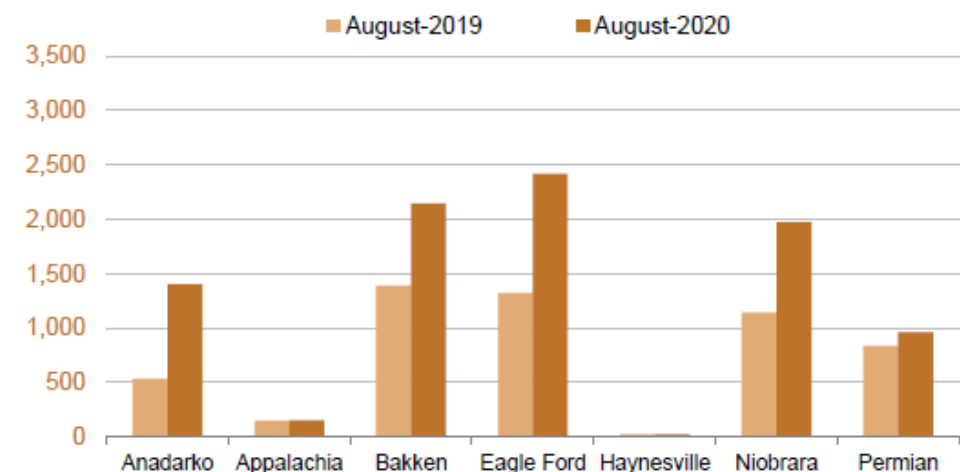

New-well gas production per rig
thousand cubic feet/day

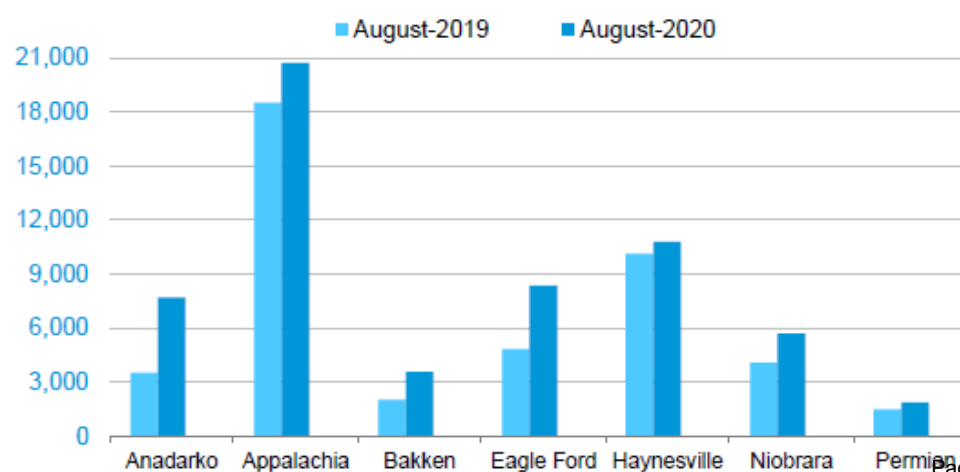

Historic Cash prices (Jan. 1997 – July 2020)

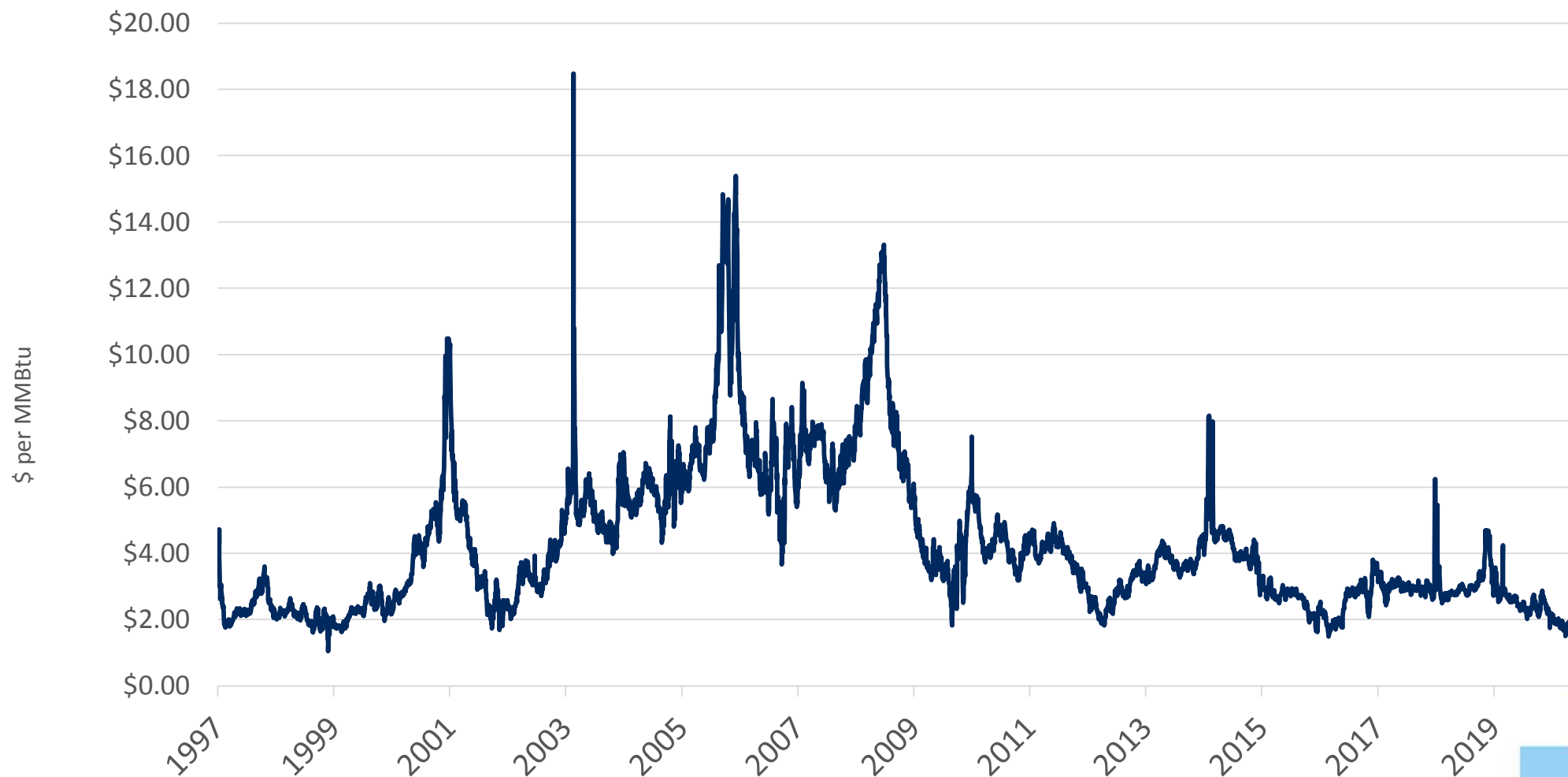



Upstream Emissions

Tom Pardee

Upstream Emissions

- Use based greenhouse gas emissions at the point of combustion and include upstream methane emissions
- Link for Natural Gas Advisory Committee information on upstream methane: <https://www.nwcouncil.org/energy/energy-advisory-committees/natural-gas-advisory-committee>

Global Warming Potential

5th Assessment of the Intergovernmental Panel on Climate Change		
Greenhouse Gas	GWP – 100 Year	GWP – 20 Year
CO ₂	1	1
CH ₄	34	86
N ₂ O	298	268

Global warming potential (GWP) factors for conversion to CO₂ equivalents (CO₂e)

<https://www.c2es.org/content/ipcc-fifth-assessment-report/>

Upstream Emissions Sources and Estimates

- Rockies emissions – The EPA estimates all leakage through a bottoms up analysis. It will estimate leaks based on equipment operated as designed and combines these values to determine an overall rate of 1%. The emissions and sinks study is published yearly and will capture emissions as they change.
- Canadian emissions (British Columbia and Alberta) – A value of 0.77% was developed from data pertaining to the recent environmental impact studies for the PSE Tacoma LNG plant, Kalama Manufacturing and Export Facility and the 2019 Puget Sound Energy IRP.

WSU Natural Gas Methane Study

- Sponsored by EDF and utilities to estimate the leakage of distribution systems
- National project and estimated a loss of **0.1 – 0.2** percent of the methane delivered nationwide
- Western region contributes much less as compared to the East
- “Out of **230 measurements, three large leaks accounted for 50%** of the total measured emissions from pipeline leaks. In these types of emission studies, a few leaks accounting for a large fraction of total emissions are not unusual.”

LDC Upstream Emissions

	Avista Specific Natural Gas	
Combustion	Lbs. GHG/MMBtu	Lbs. CO2e/Mmbtu
CO2	116.88	116.88
CH4	0.0022	0.0748
N2O	0.0022	0.6556
Total Combustion		117.61
Upstream		
CH4	0.313406851	10.66
Total		128.27
Upstream Emissions	Avista's Purchases	Emissions Location
0.77	89.72%	Canada
1.00	10.28%	Rockies
0.79		

*Avista gas purchases

An average of the total volume purchased over the past 5 years by emissions location

Electric Upstream Emissions

	Avista Specific Natural Gas	
Combustion	Lbs. GHG/MMBtu	Lbs. CO2e/Mmbtu
CO2	116.88	116.88
CH4	0.0022	0.0748
N2O	0.0022	0.6556
Total Combustion		117.61
Upstream		
CH4	0.304065693	10.34
Total		127.95
Upstream Emissions	Avista's Purchases	Emissions Location
0.77	100.00%	Canada
1.00	0.00%	Rockies
0.77		

*Avista Purchases

All firm transportation to supply gas is located in Canada



Renewable Natural Gas (RNG)

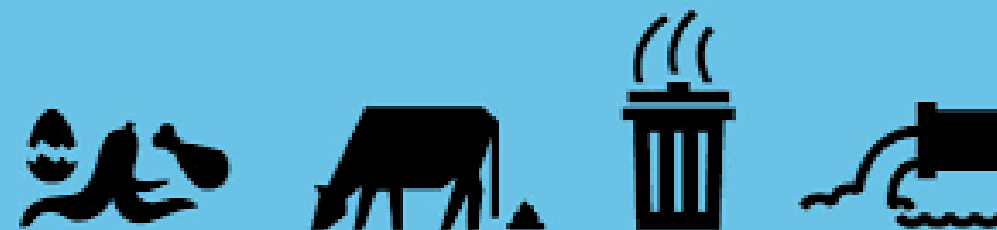

What is Renewable Natural Gas (RNG)?

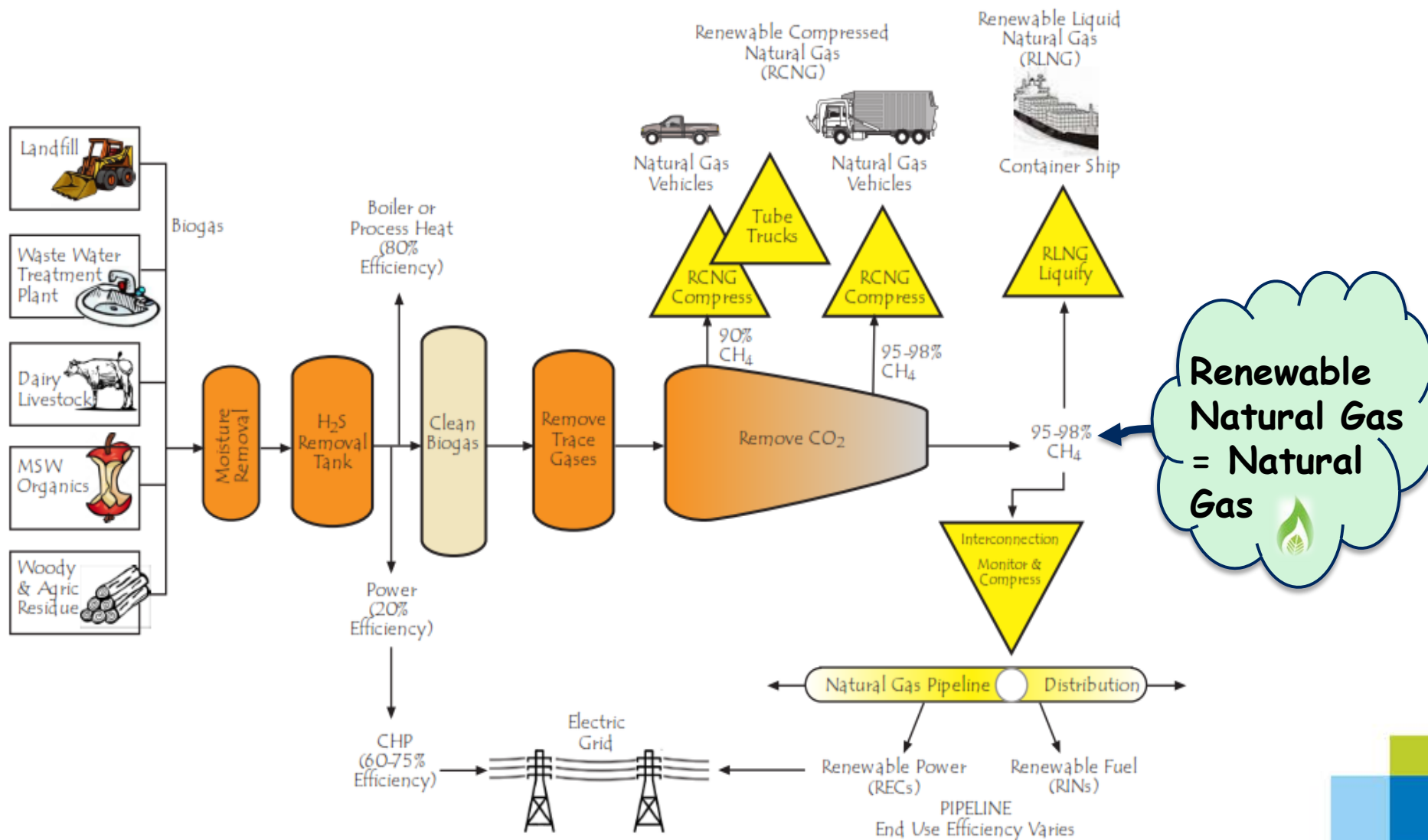

Why does RNG matter?

Climate Change Solution

- Natural gas plays critical role for meeting aggressive green house gas (GHG) reductions goals, RNG even more so!
- Utilizes existing infrastructure
- Advantages of RNG
 - “De-carbonizes” gas stream
 - Gives customers another renewable choice

Carbon Intensity

Fuel Pathway	Carbon Intensity $\frac{gCO_2e}{MJ}$
Diesel*	102.01
Gasoline*	99.78
Fossil CNG†	78.37
Landfill CNG†	46.42
WWTP CNG*	19.34
MSW CNG*	-22.93
Dairy CNG‡	-276.24

*California Code of Regulation Title 17, §95488, Table 6. Carbon intensity for WWTP is the average of two WWTP pathways.

†California Code of Regulation Title 17, §95488, Table 7.

‡Method 2B Application CalBio LLC, Dallas Texas, Dairy Digester Biogas to CNG.

RFS and LCFS Effect on RNG Value

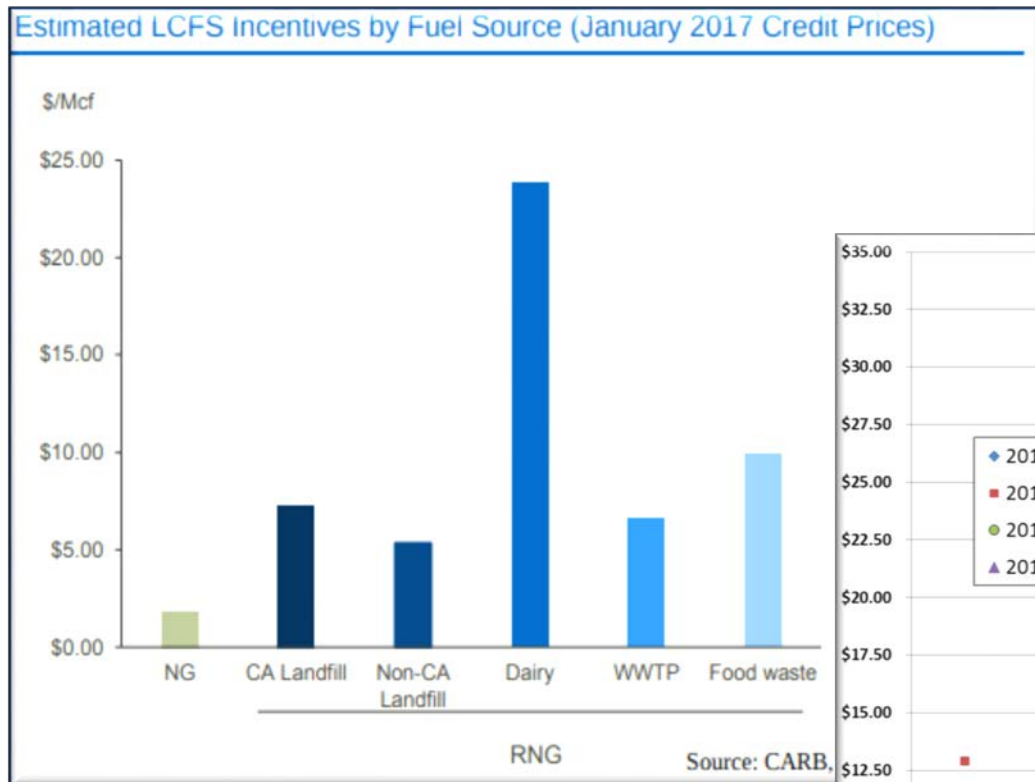

RIN = renewable identification number

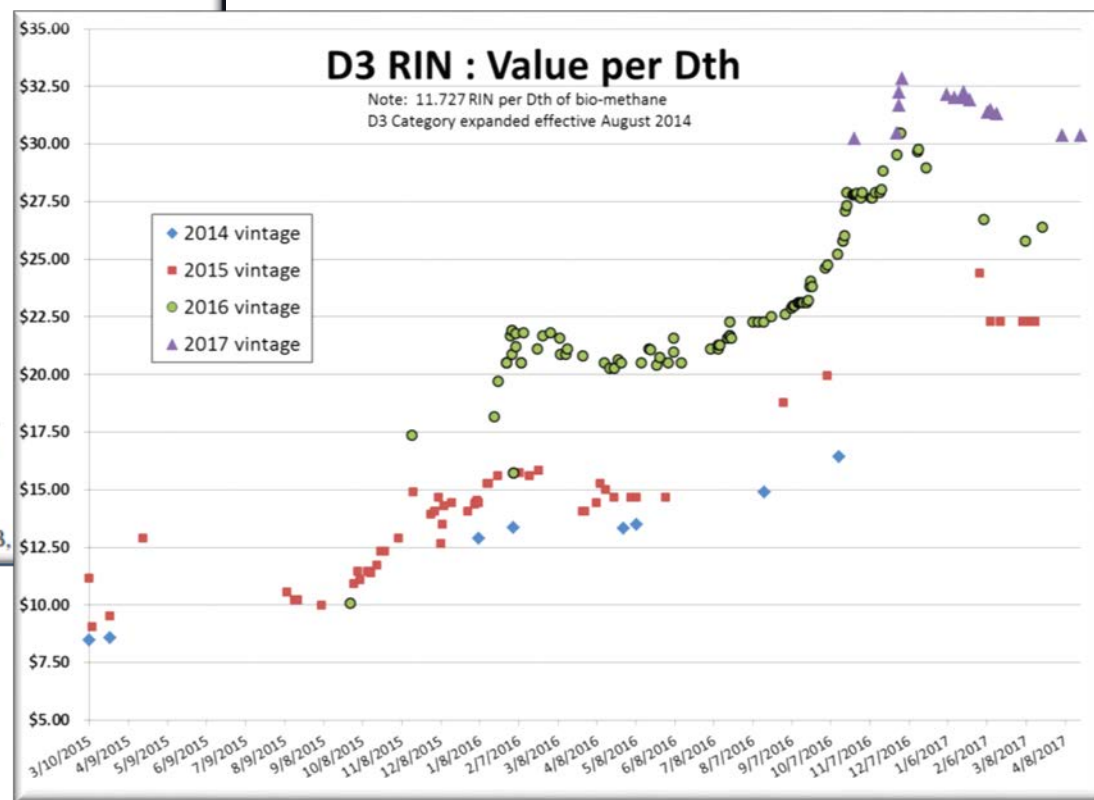

What are the challenges & barriers?

- California RNG market (\$30+/Dth v. \$2/Dth)
 - Vehicle emission incentives shut-out other potential end users
 - Producers see the pot of gold in California
- Financing for producers
 - RIN market is volatile
 - No forward pricing for RNG RINs in carbon market
 - Vehicle market may be approaching saturation in CA
 - Producer/LDC partnerships may make sense

WA RNG Report (HB 2580)

Existing Projects
 Near Term Projects
 Medium Term Projects

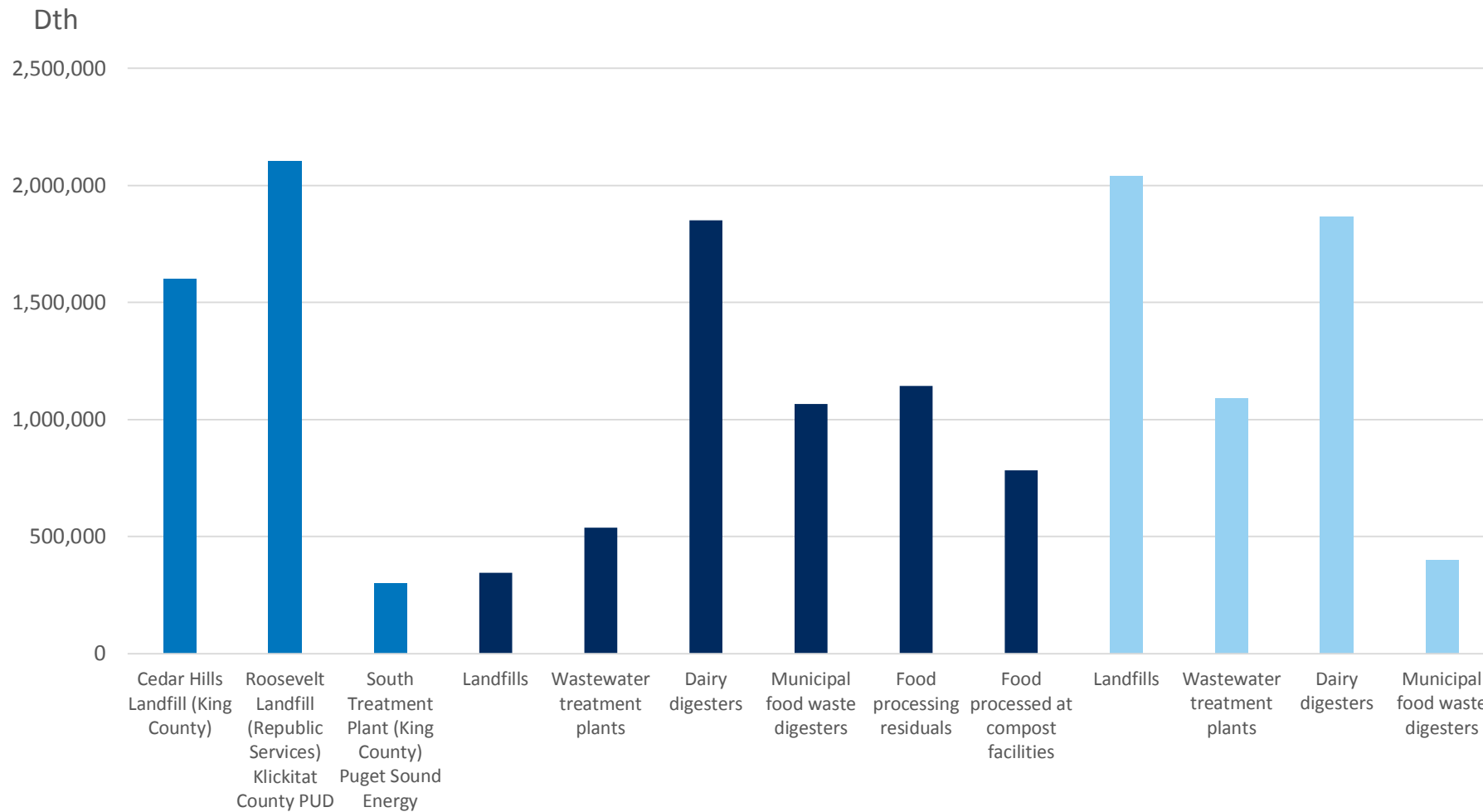

WSU Energy Program, Harnessing Renewable Natural Gas for Low-Carbon Fuel: A Roadmap for Washington State

*Released December 1, 2018



ID RNG NREL Estimates

Total Potential Annual Production = 32 Bcf

Source - Anaerobic	MMBtu per Year
Landfills	3,712,221
Wastewater Treatment	6,196,531
Agriculture Manure	20,220,571
Source-Separated Organics (Solid Waste)	2,311,354
Total	32,440,676

National Renewable Energy Laboratory, NREL Biofuels Atlas

RNG \$ per Dth/MMBtu

Avista Owned and Operated	ID - WA 2035 Premium Estimate (\$ / Dth)
RNG - Landfills	\$7 - \$10
RNG - Waste Water Treatment Plants (WWTP)	\$12 - \$22
RNG - Agriculture Manure	\$28 - \$53
RNG - Food Waste	\$29 - \$53

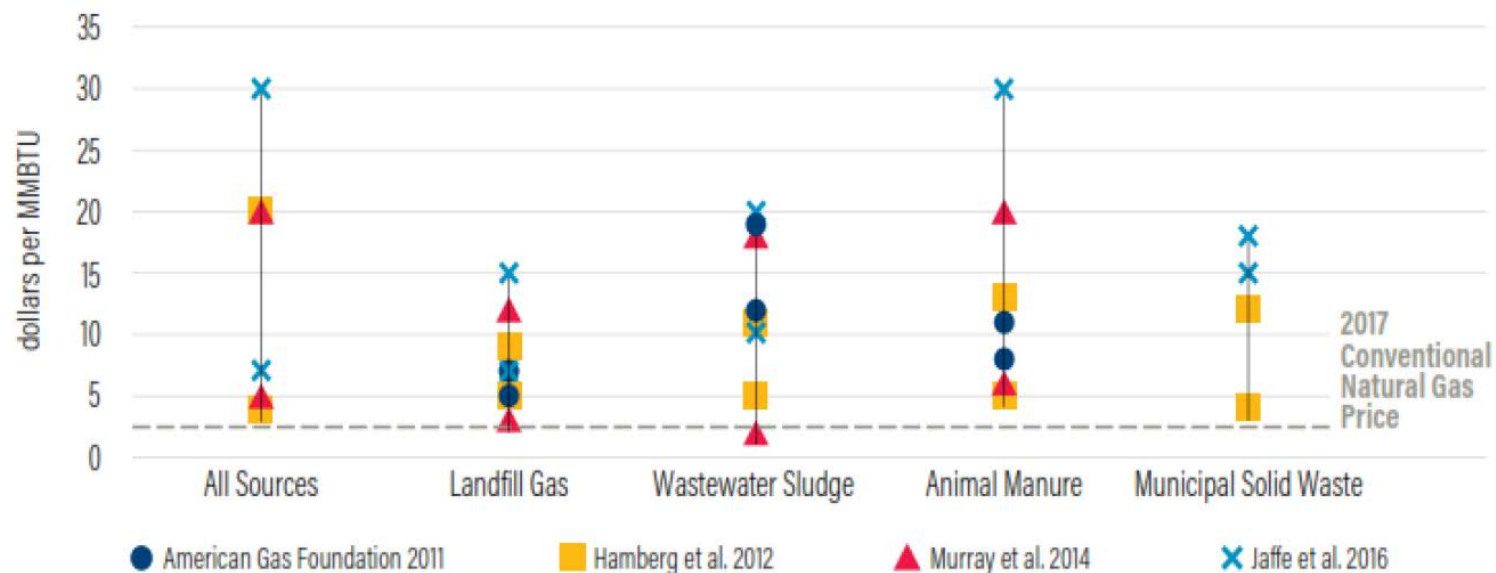

Source: Promoting RNG in WA State

Natural Gas IRP

A detailed level of RNG understanding and evaluation process will be included in the Natural Gas IRP TAC #3 meeting on September 30, 2020



Natural Gas Price Forecast

Michael Brutocao, Natural Gas Analyst
Second Technical Advisory Committee Meeting
August 6, 2020

Henry Hub Expected Price Methodology

- Expected Henry Hub prices derived from a blend of forward market prices on the NYMEX (as of 6/30/2020) and forecasted prices from the 2020 Annual Energy Outlook (EIA) and two consultants

	2020 – 2022	2023	2024	2025	2026 – 2045
NYMEX	100%	75%	50%	25%	-
EIA/AEO	-	8.33%	16.66%	25%	33.33%
Consultant 1	-	8.33%	16.66%	25%	33.33%
Consultant 2	-	8.33%	16.66%	25%	33.33%

Henry Hub Expected Price and Forecast Blending

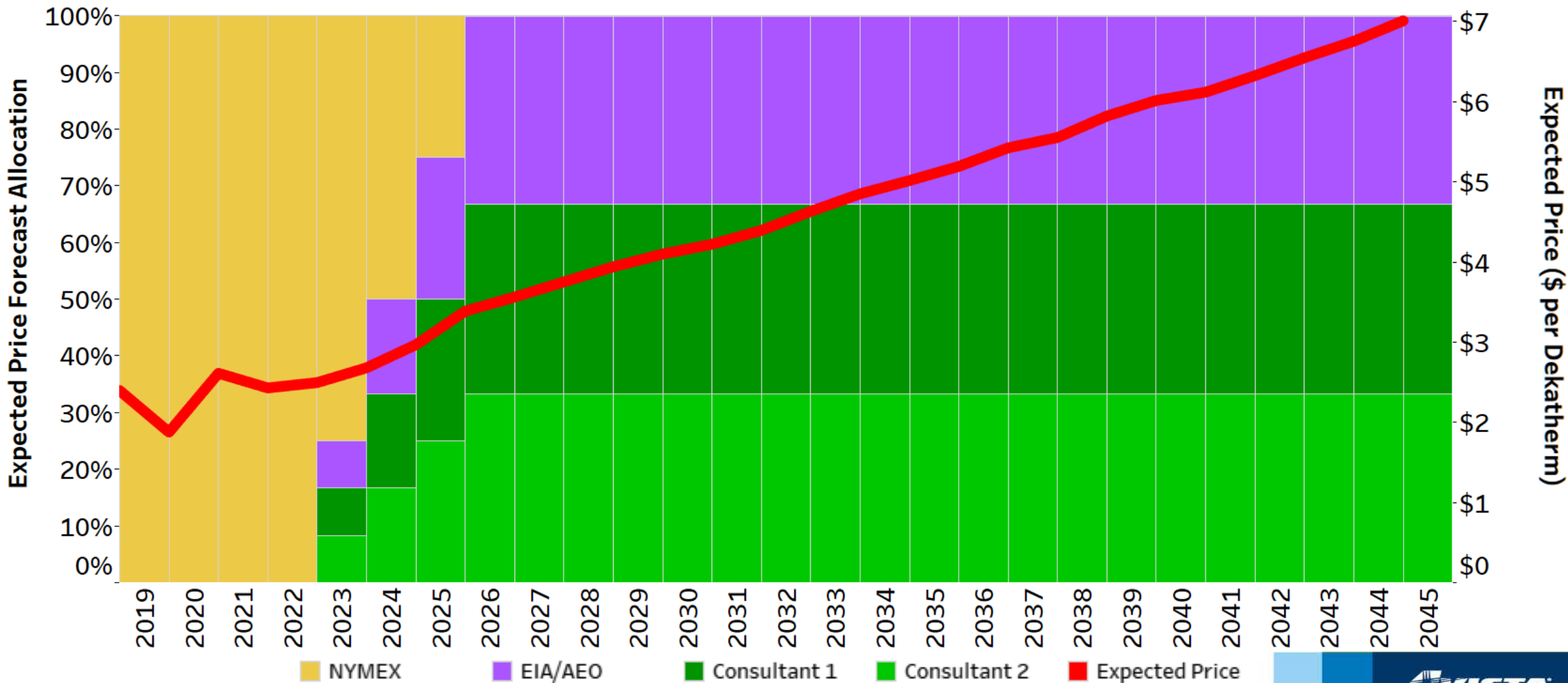

Henry Hub Expected Price and Average Annual Forecasts

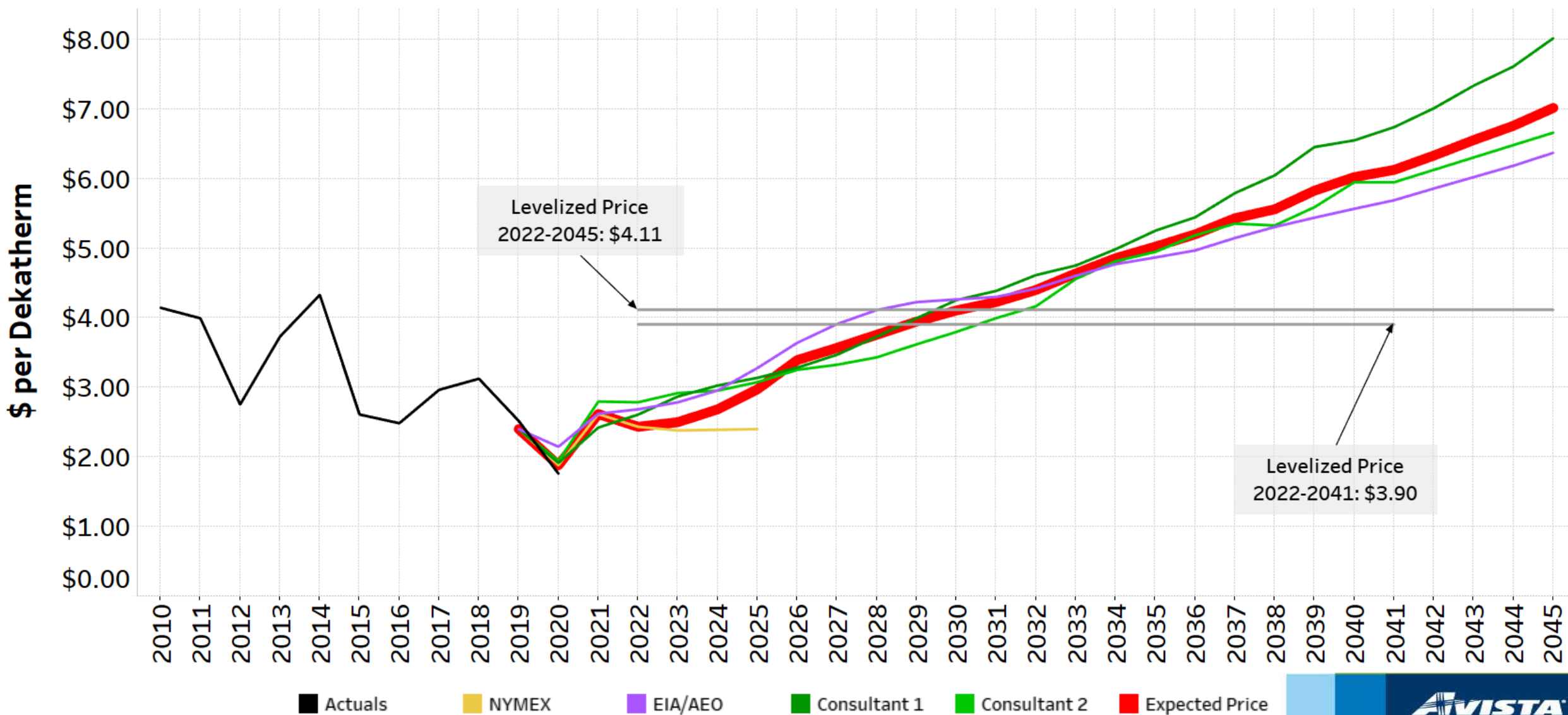

Actuals
 NYMEX
 EIA/AEO
 Consultant 1
 Consultant 2
 Expected Price



Stochastic Price Forecasting Methodology

- Evaluate a set of potential future outcomes based on the probability of occurrence
 - Expected Price used as the input
 - At each period, random price adjustments follow a lognormal distribution based on the Expected Price
 - It is common practice to use lognormal distributions in forecasting prices as they have no upward bound and should not fall below zero
- A single “draw” contains a set of unique price movements
- 500 (electric) and 1000 (gas) draws were evaluated

Sample Stochastic Price Draws

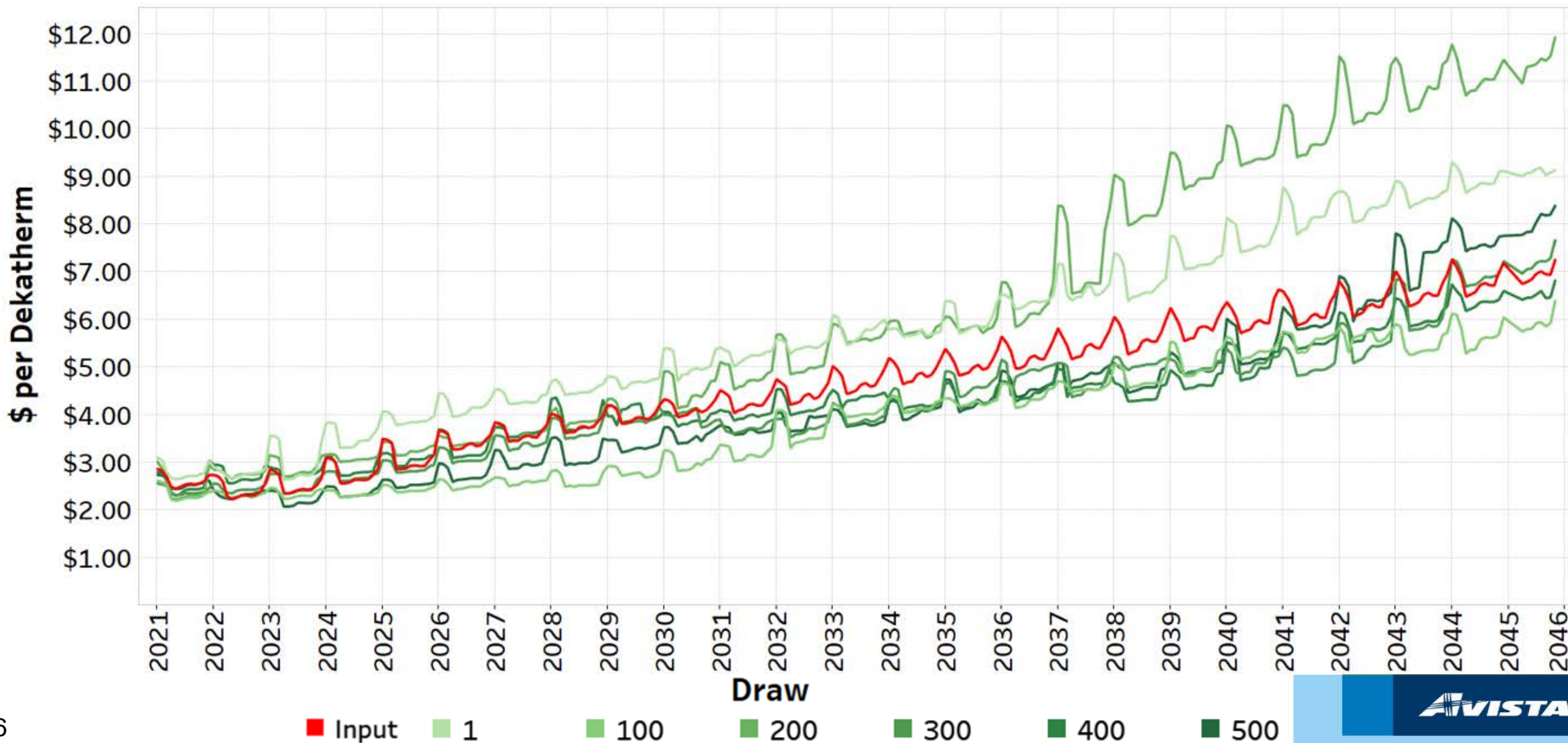

Stochastic Price Draws

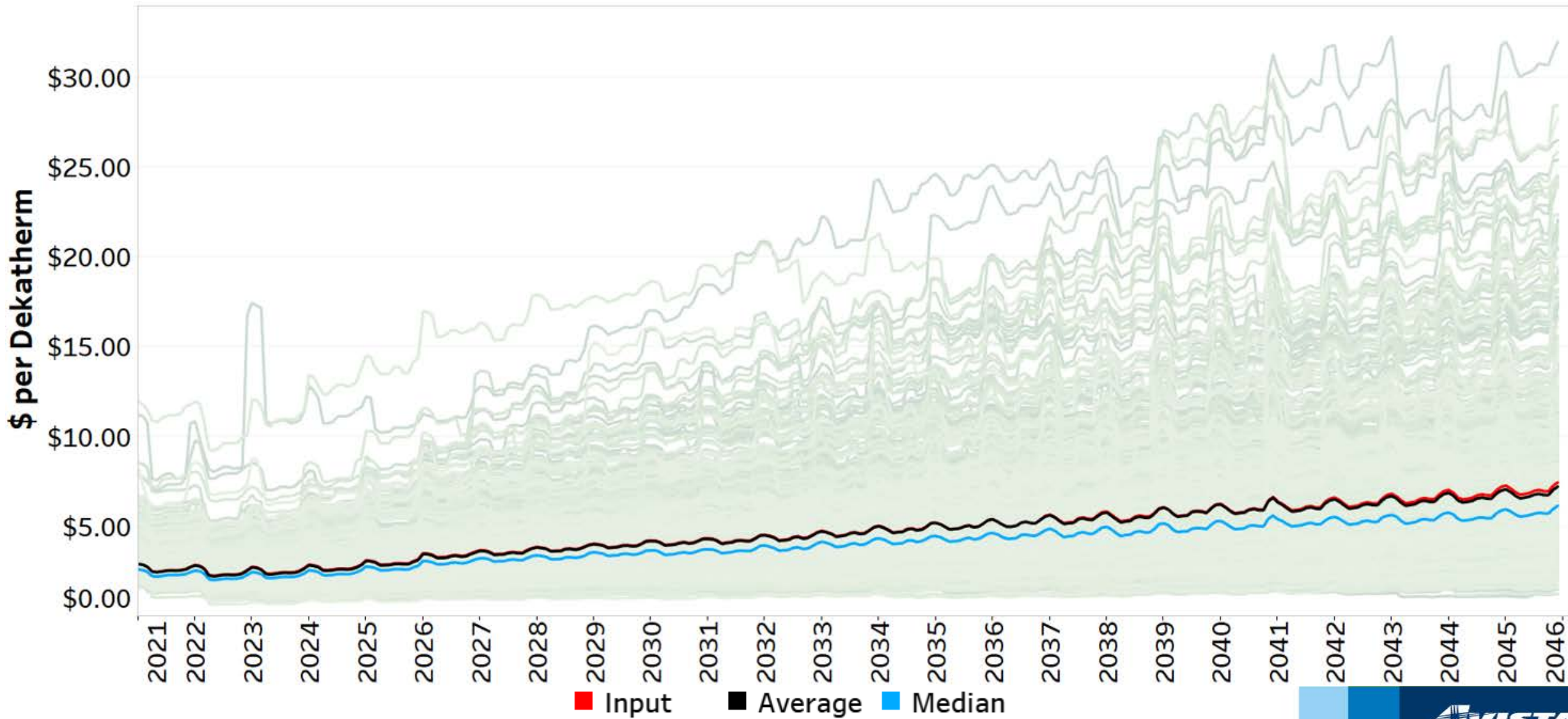

Stochastic Prices (Results from 500 Draws)

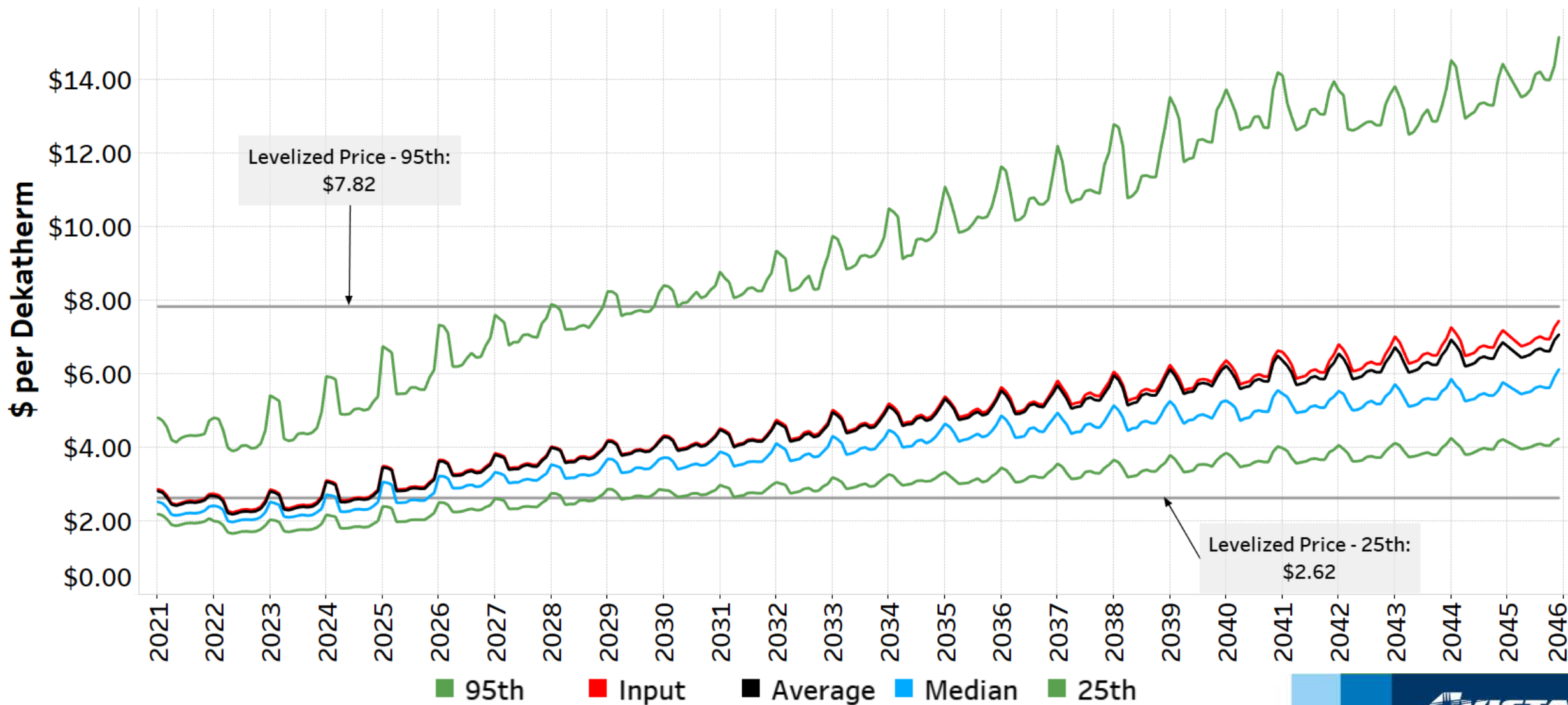

Levelized Stochastic Prices (Results from 500 Draws)

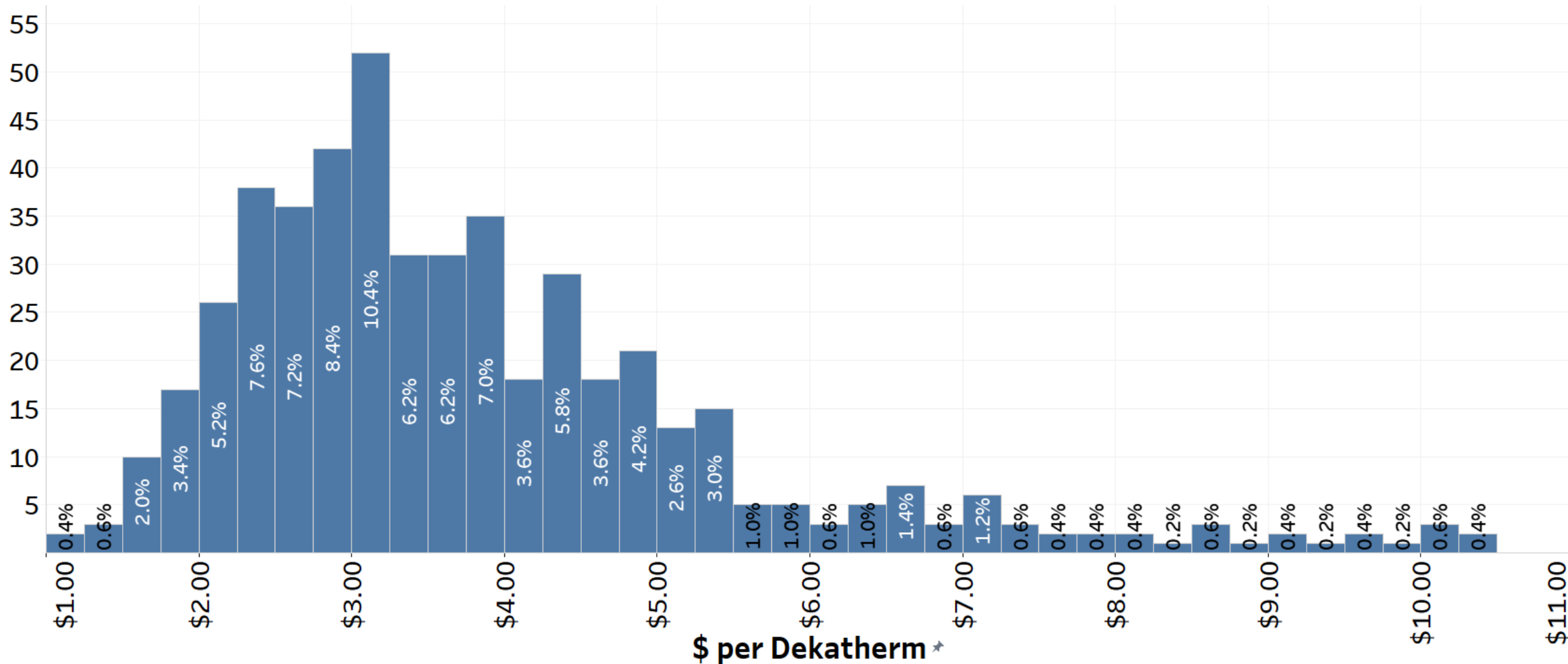

Stochastic Prices (Results from 1000 Draws)

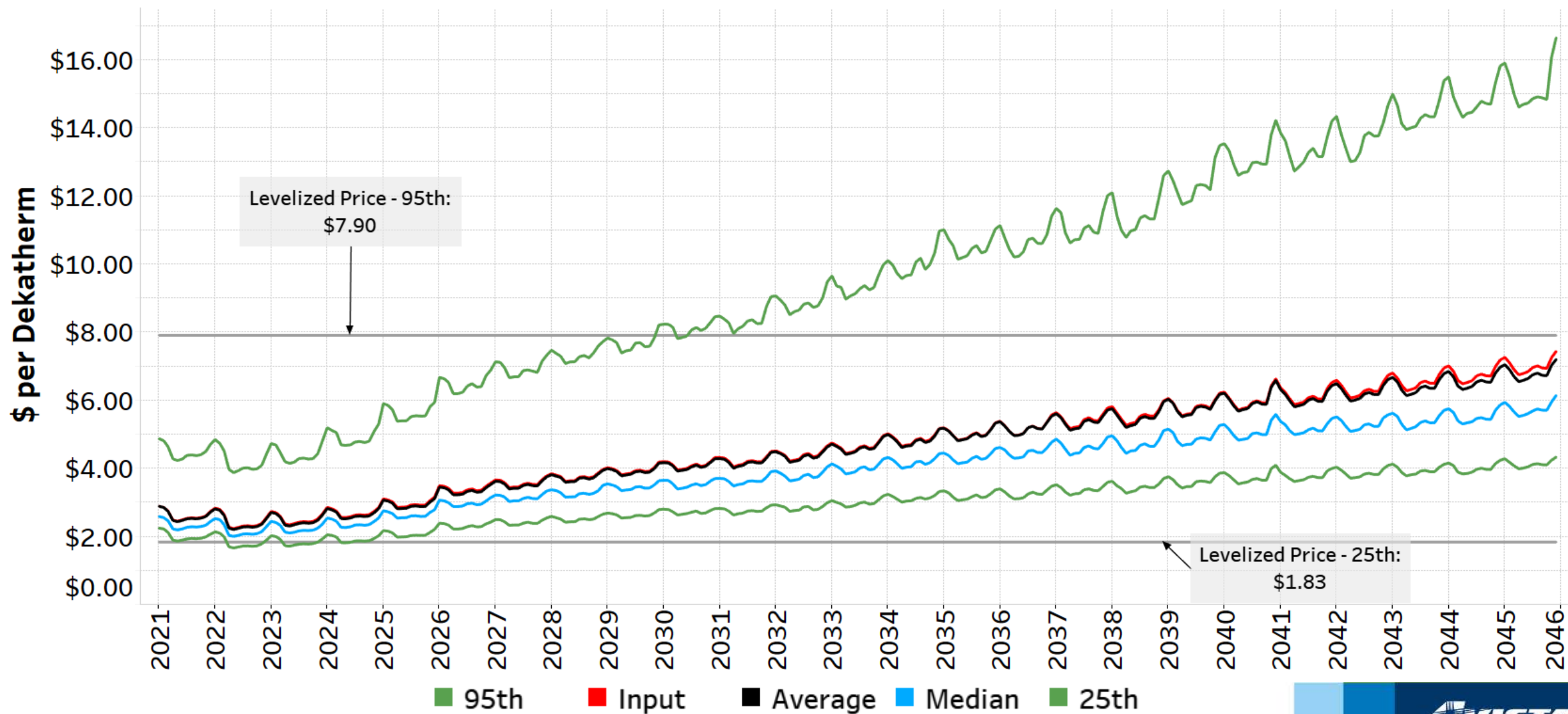

Levelized Stochastic Prices (Results from 1000 Draws)

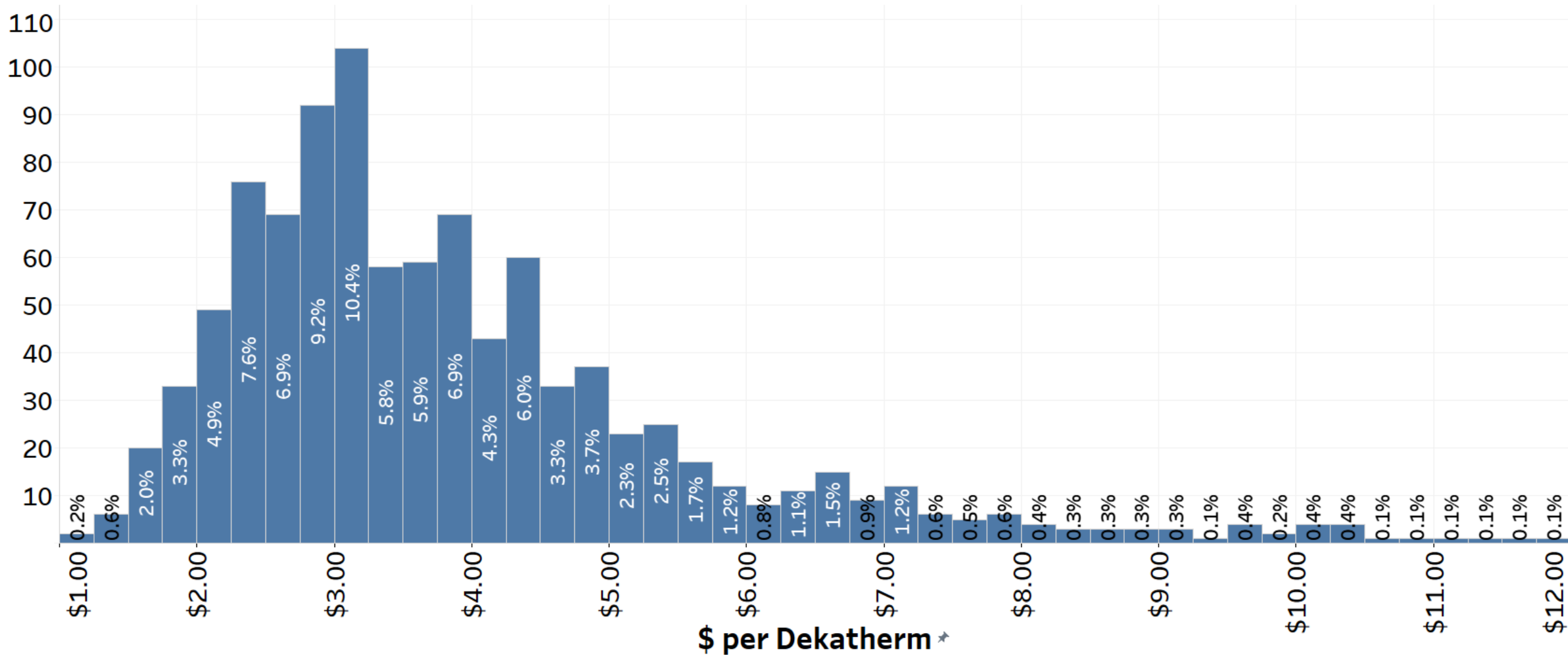

Prices by Gas Hub (Henry Hub Expected Price + Basis)

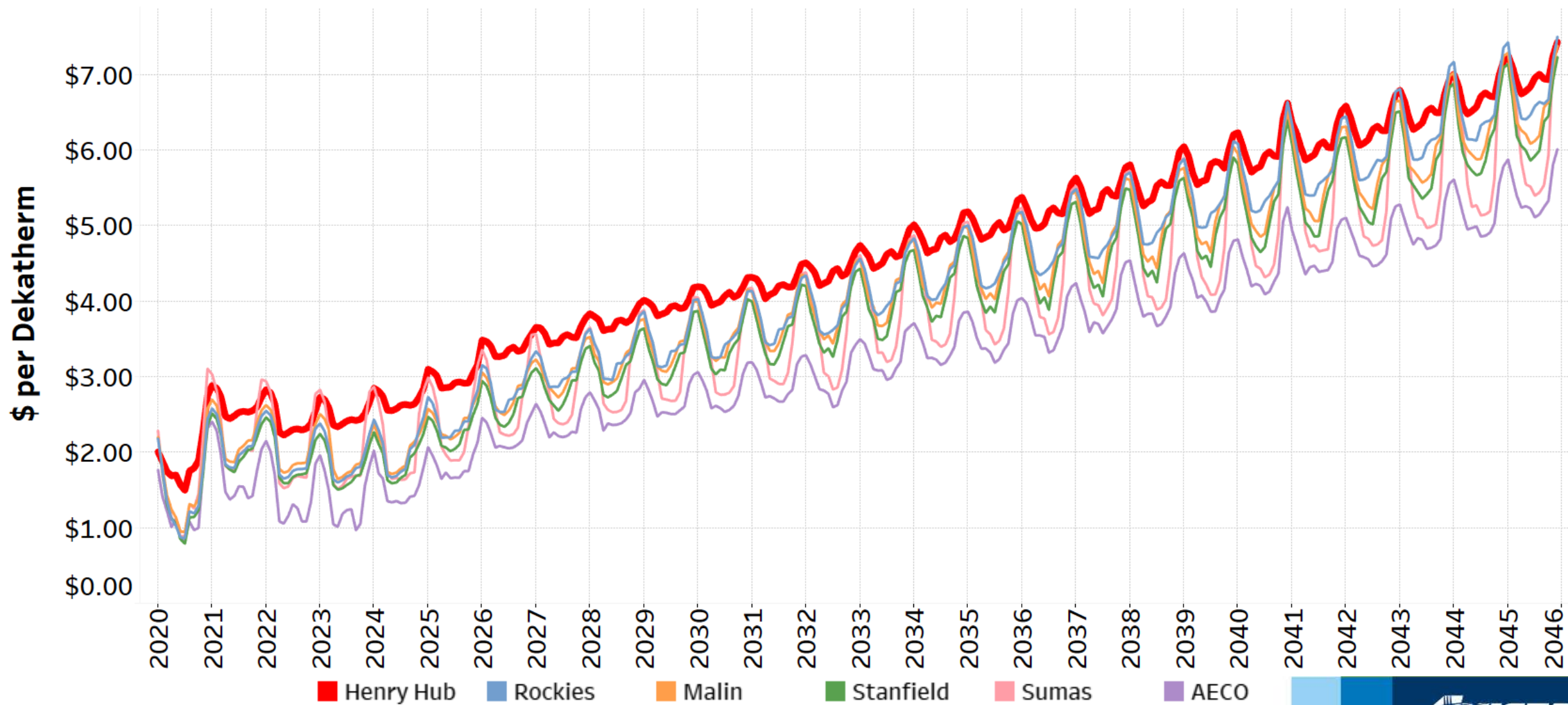

Levelized Prices 2022-2041



Levelized Prices 2022-2045





2021 Electric IRP Regional Energy Policy Update

John Lyons, Ph.D.
Second Technical Advisory Committee Meeting
August 6, 2020

Production and Investment Tax Credits

- Production tax credit \$15/MWh adjusted for inflation (\$25/MWh for 2019) for 10 years for wind construction started by 12/31/20
- Investment tax credit for new solar construction drops from 30% in 2019
 - 26% in 2020
 - 22% in 2021
 - 10% from 2022 onward
- Will be watching for any possible extensions with all of the COVID-19 proposals

State and Provincial Policies

State/Province	No Coal	RPS	Clean Energy/Carbon Goal
Alberta	Yes	Yes	Yes
Arizona	No	Yes	No
British Columbia	Yes	Yes	Yes
California	Yes	Yes	Yes
Colorado	No	Yes	Yes
Idaho	No	No	No
Montana	No	Yes	No
Nevada	No	Yes	Goal
New Mexico	No	Yes	No
Oregon	Yes	Yes	Yes
Utah	No	Goal	No
Washington	Yes	Yes	Yes
Wyoming	No	No	No

Washington

- Clean Energy Transformation Act (CETA) SB 5116:
 - No coal serving Washington customers by end of 2025
 - Greenhouse gas neutral by 2030, up to 20% alternative compliance
 - 2% cost cap over four-year compliance period
 - 100% non-emitting by January 1, 2045
 - Social cost of carbon for new resources
 - Additional reporting and planning requirements
 - Highly impacted and vulnerable community identification and resource planning implications
 - Ongoing rulemaking in various stages for planning and reporting

Washington

- **HB 1257: Clean Buildings for Washington Act**
 - Develop energy performance standards for commercial buildings over 50,000 square feet (2020 – 2028) “... to maximize reductions of greenhouse gas emissions from the building sector”
 - By 2022, natural gas utilities must identify and acquire all available cost-effective conservation including a social cost of carbon at the 2.5% discount rate.(Section 11 and 15)
 - Natural gas utilities may propose renewable natural gas (RNG) programs for their customers and offer a voluntary RNG tariff
 - Building code updates to improve efficiency and develop electric vehicle charging infrastructure

Oregon

Executive Order 20-04

- New GHG reduction goal
 - 45% below 1990 levels by 2035
 - 80% below 1990 levels by 2050
- Directs 16 Oregon agencies to “exercise any and all authority and discretion” to reach GHG reduction goals and “prioritize and expedite” action on GHG reductions “to the full extent allowed by law.”
- Agencies are working on rulemaking and implementation

SB 98

- Development of utility renewable natural gas programs



2021 Electric and Natural Gas IRPs Natural Gas & Electric Coordinated Scenario

James Gall/Tom Pardee
Second Technical Advisory Committee Meeting
August 6, 2020

Scenario Goal

- Understand impact to electric resource planning if customers switch from natural gas to electric service
- Scenario Proposal:
 - By 2030: 50% of Washington Residential & Commercial customers
 - By 2045: 80% of Washington Residential & Commercial customers
- Potential Scenarios:
 - Hybrid natural gas/electric heat pumps
 - Highly efficient technology allows for cold temperature space heating

Converting Natural Gas Load to Electric Load

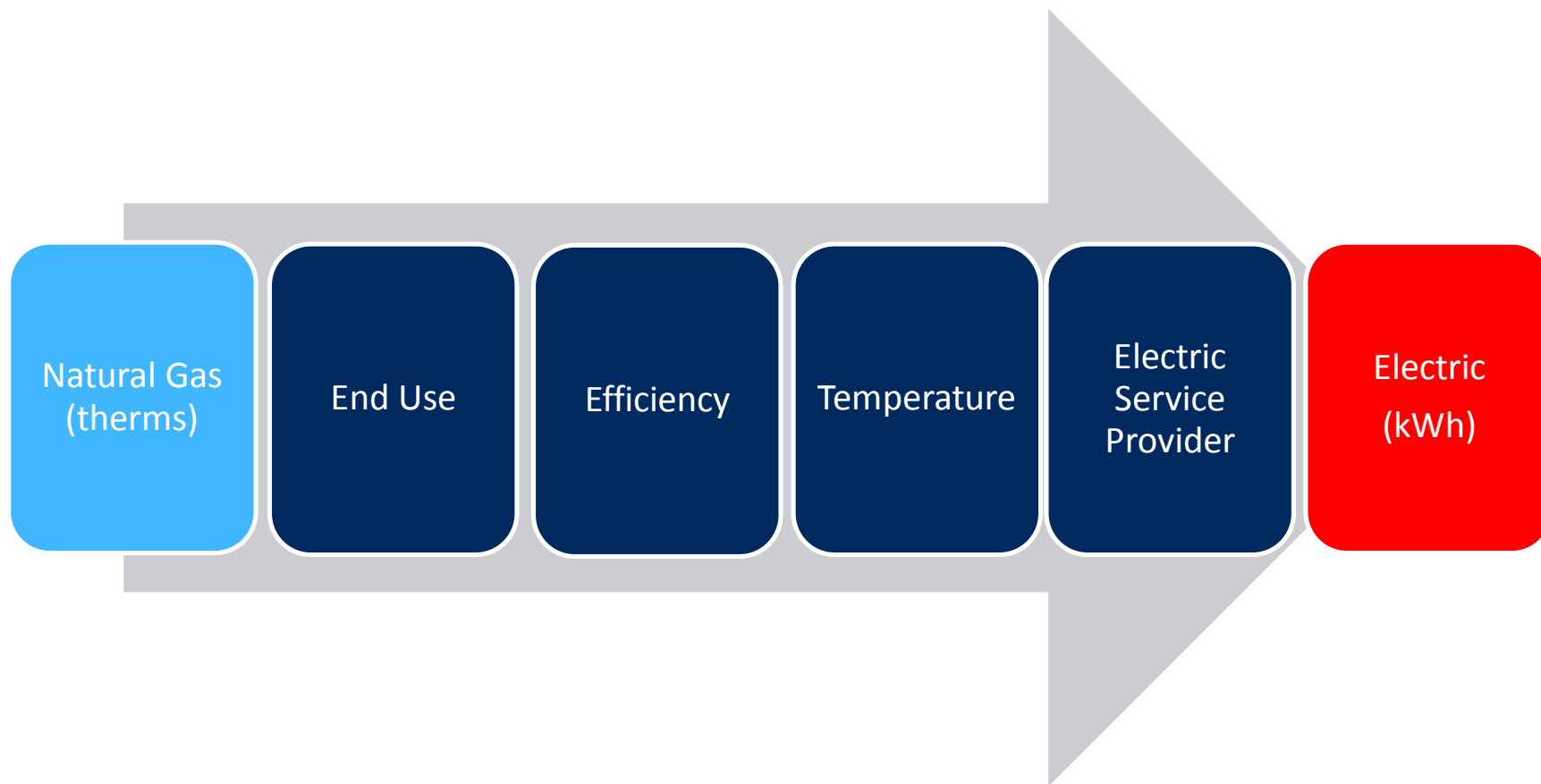

WA Res/Com Natural Gas Load Forecast

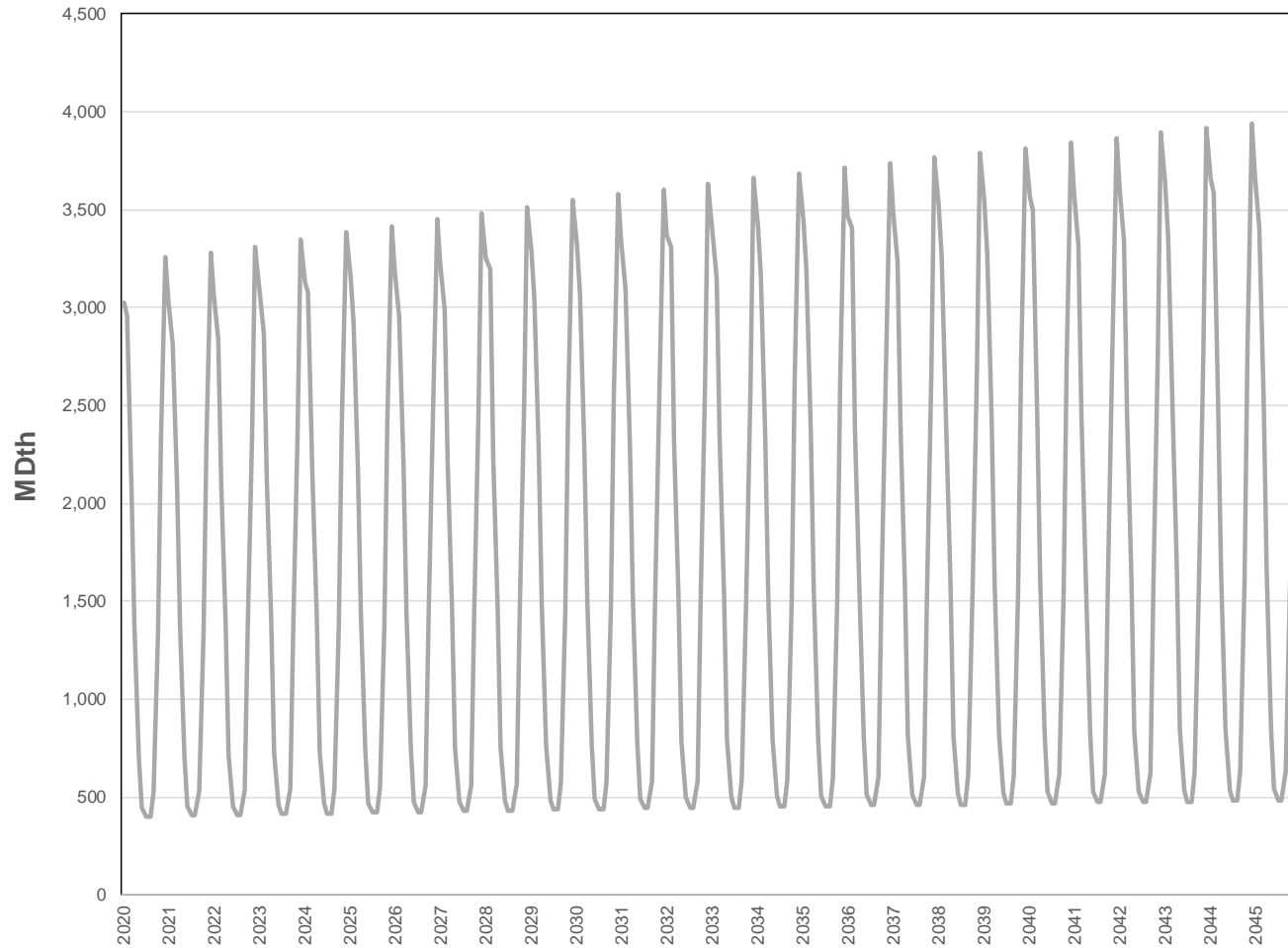

Customer Penetration Forecast

% Natural Gas Customer Reduction (WA Only)

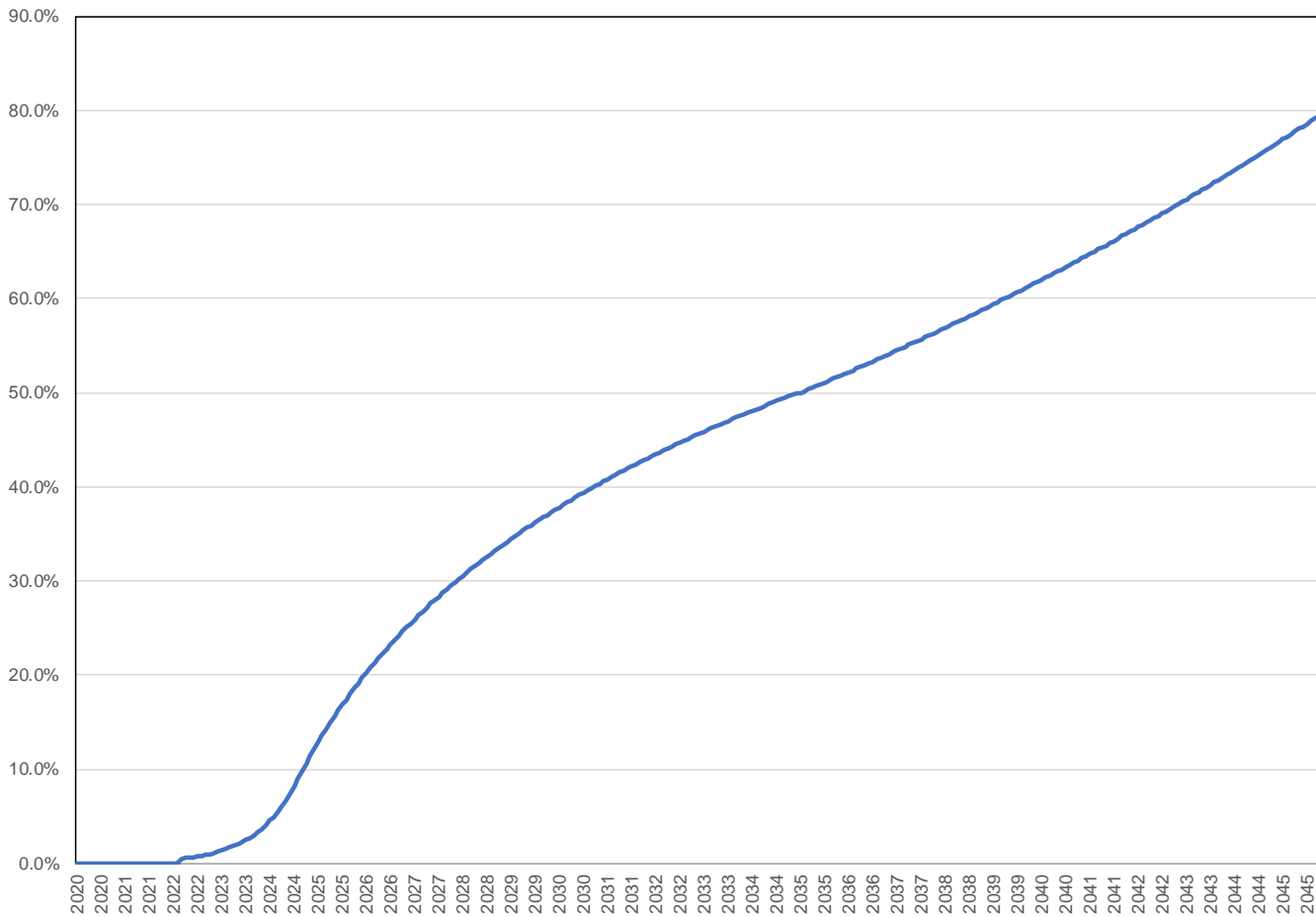

End Use Efficiency

End Use @ 5 Degrees

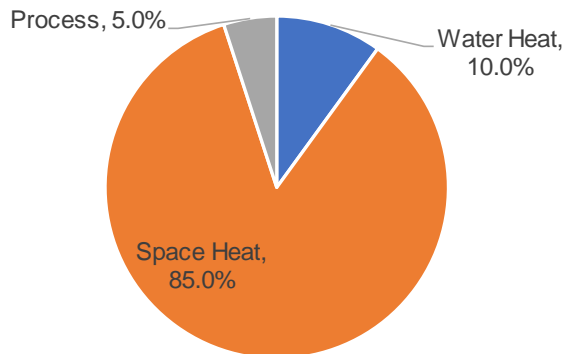

Efficiency @ 5 Degrees

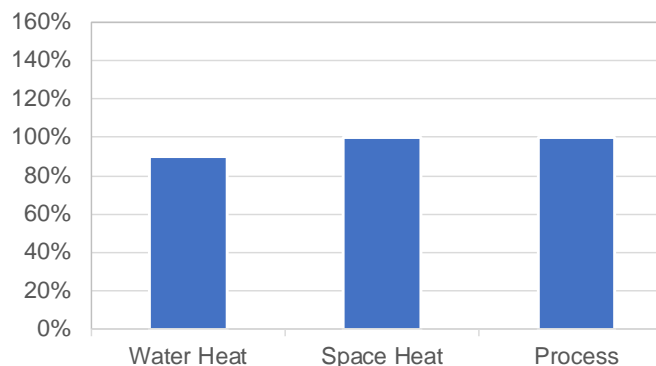

End Use @ 35 Degrees

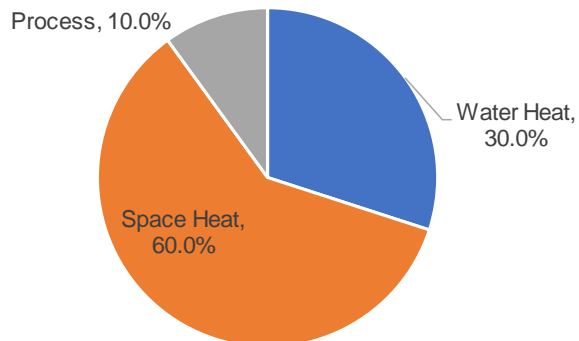

Efficiency @ 35 Degrees

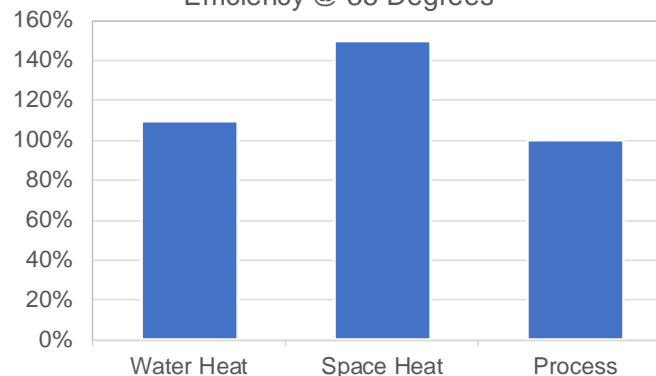

Note: All efficiency conversion use a 10% efficiency benefit to electric

Energy Conversion Factor

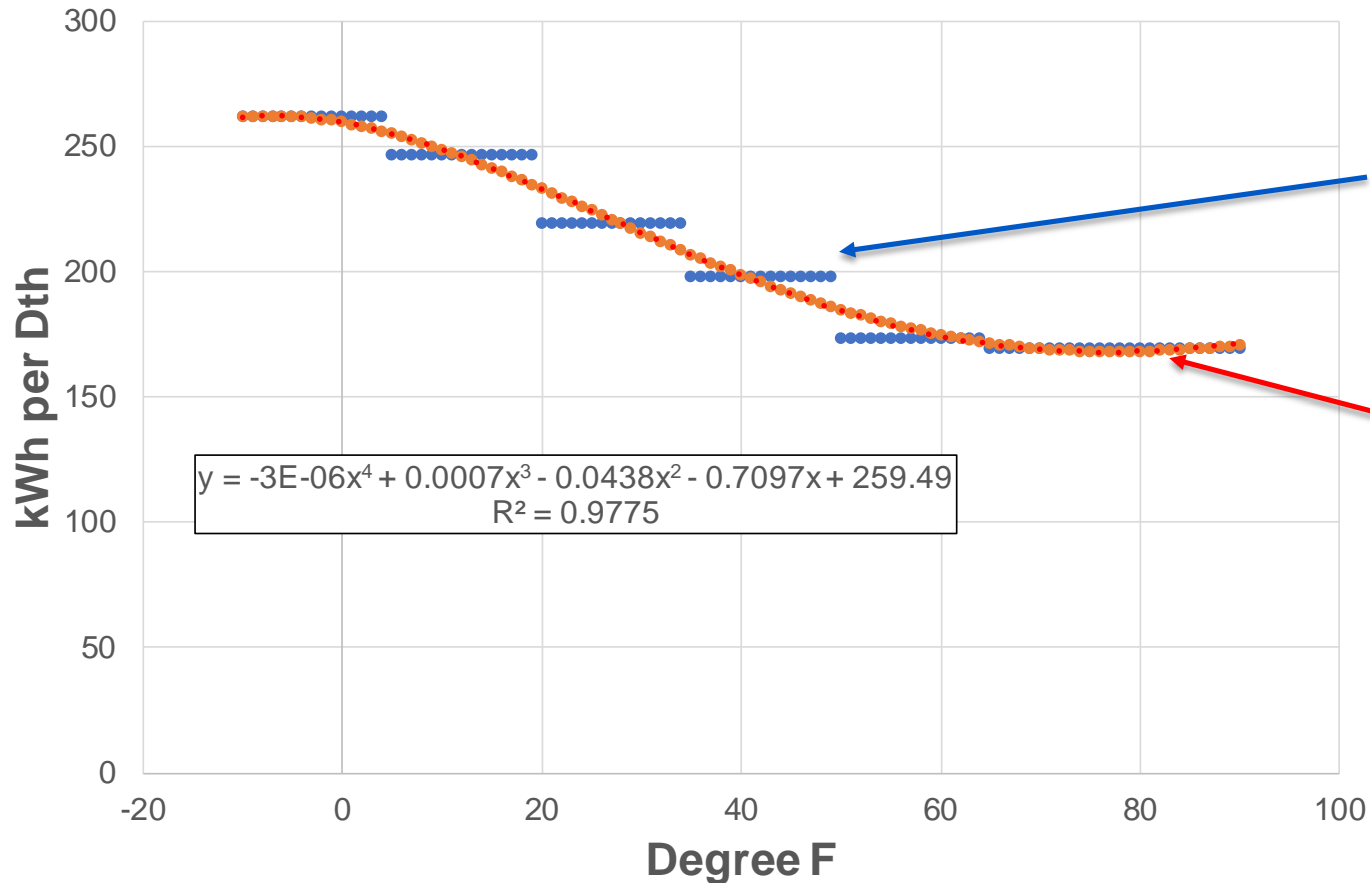

Use
temperature
point
estimates
for
conversion
efficiency

Curve fit to
smooth out
steps

WA Res/Com Natural Gas Load Forecast

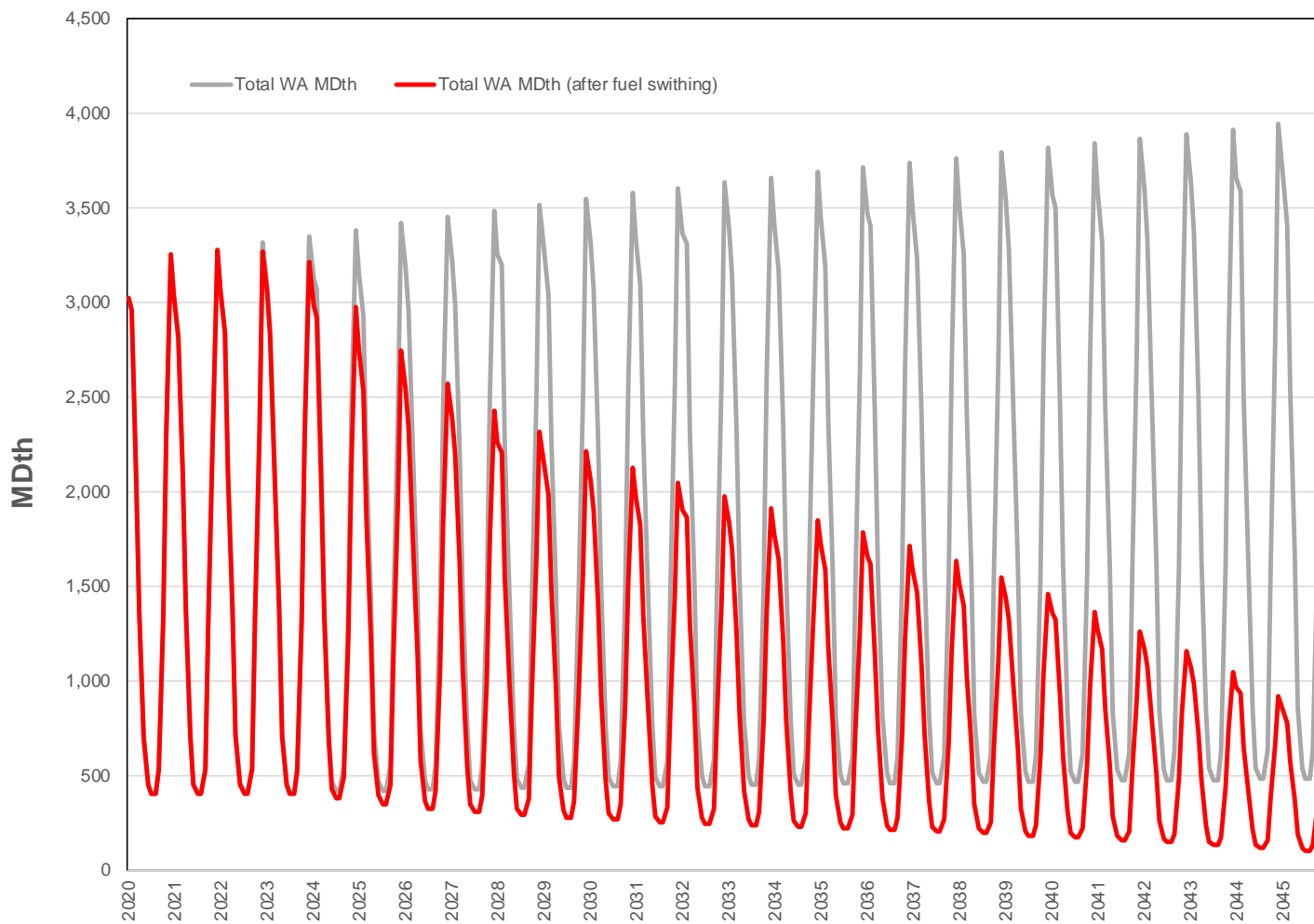

Electric Peak Estimation Methodology

- Natural gas is typically daily nominations, while electric is instantaneous.
 - Hourly flow metering is available for some areas
- Sampled large gate-station hourly instantaneous natural gas flow data
- Use sample data to estimate hourly natural gas load from 2015-2019
- Estimate Peak-to-Energy load factor for each historical month
- Use average monthly load factor for the peak adjustment

Estimated Load Factors (2015-19)

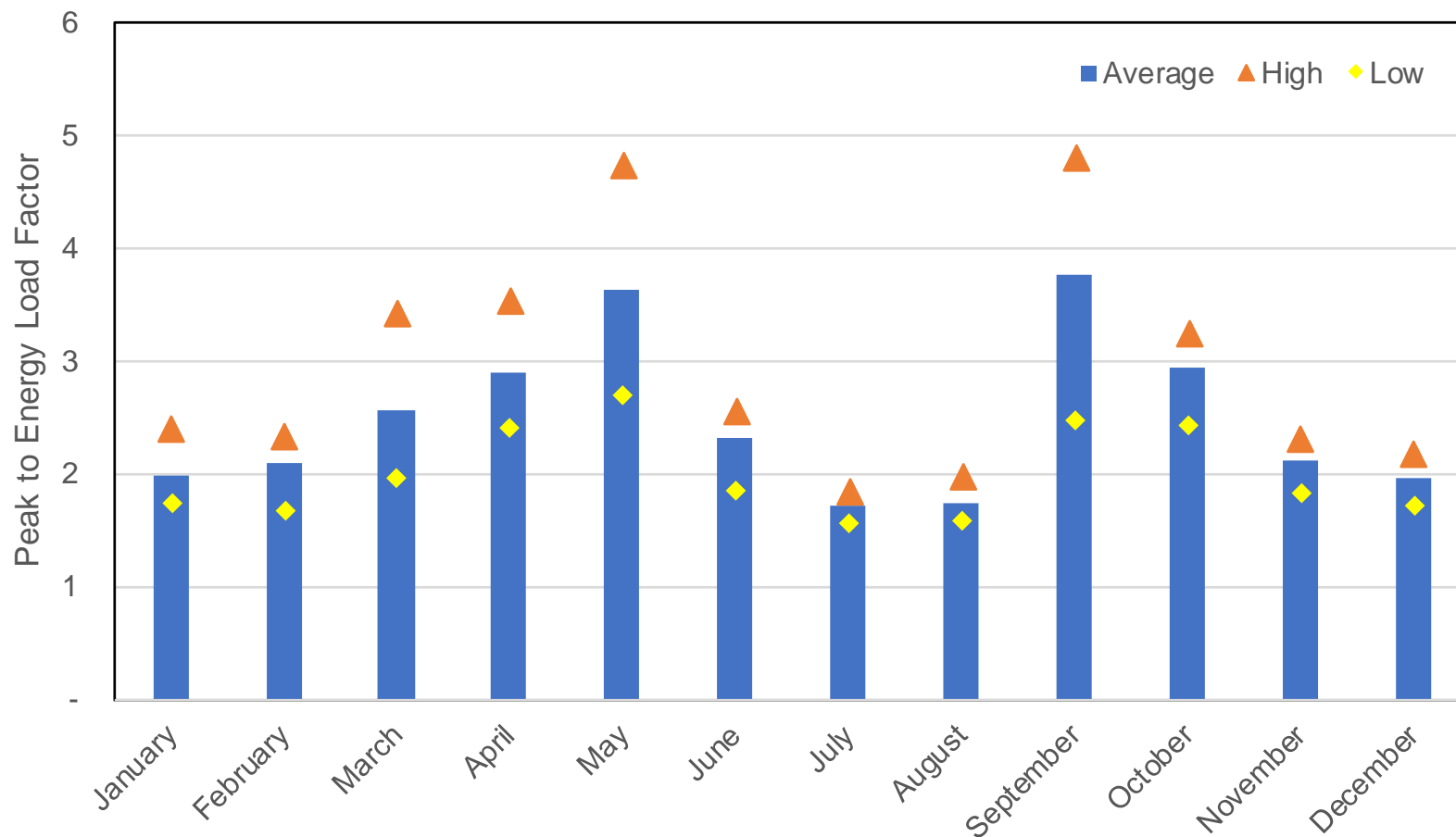

Hourly Electric Load History

2015-2019 Control Area Load + WA LDC as Electric

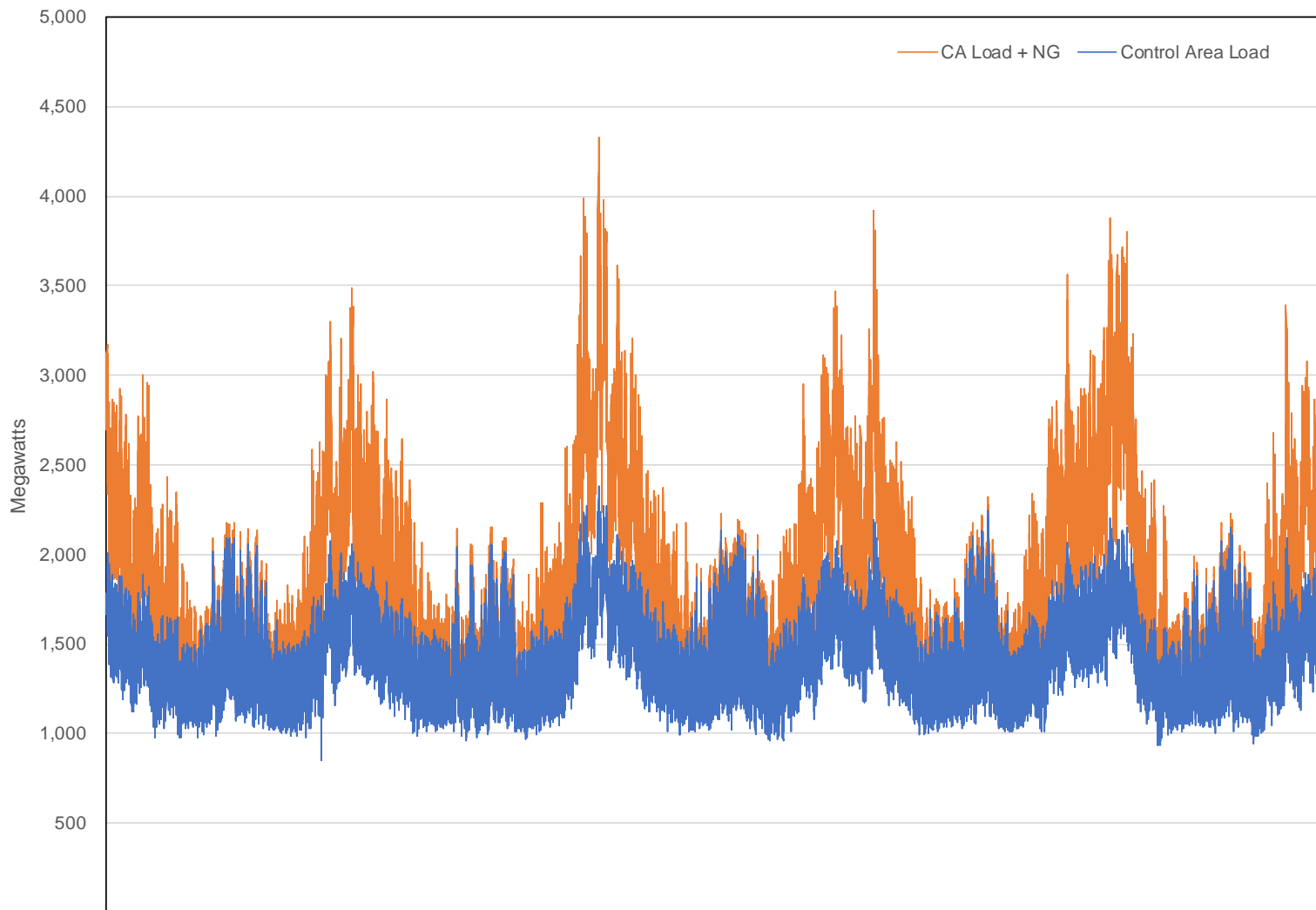

Eastern Washington Electric Service Providers

EIA reported retail sales for 2018

Scenario assumes Avista will receive 75 percent of electric conversions

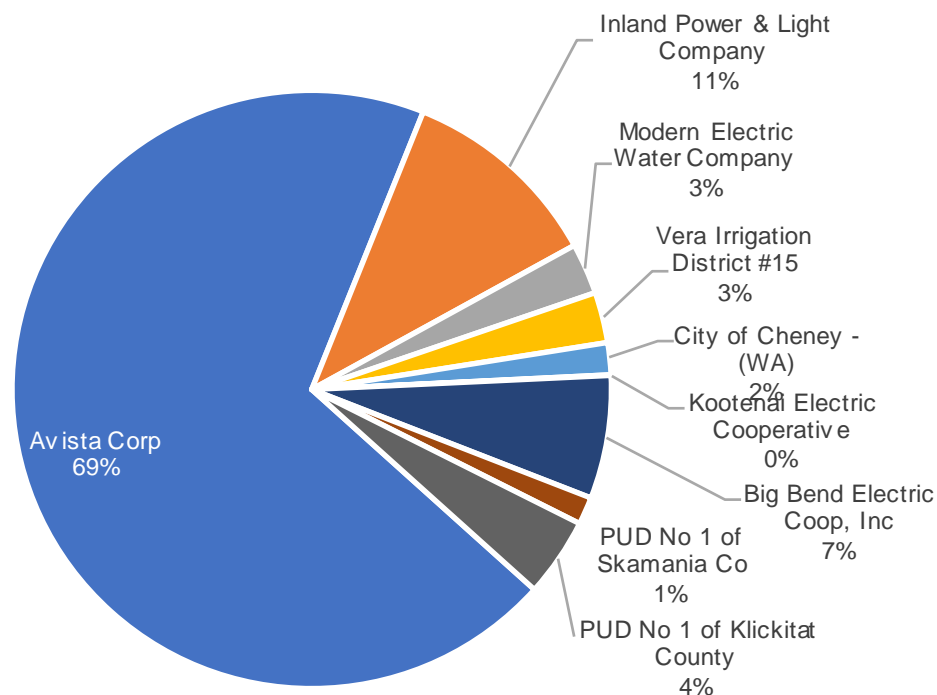

Annual Conversion Load Forecast

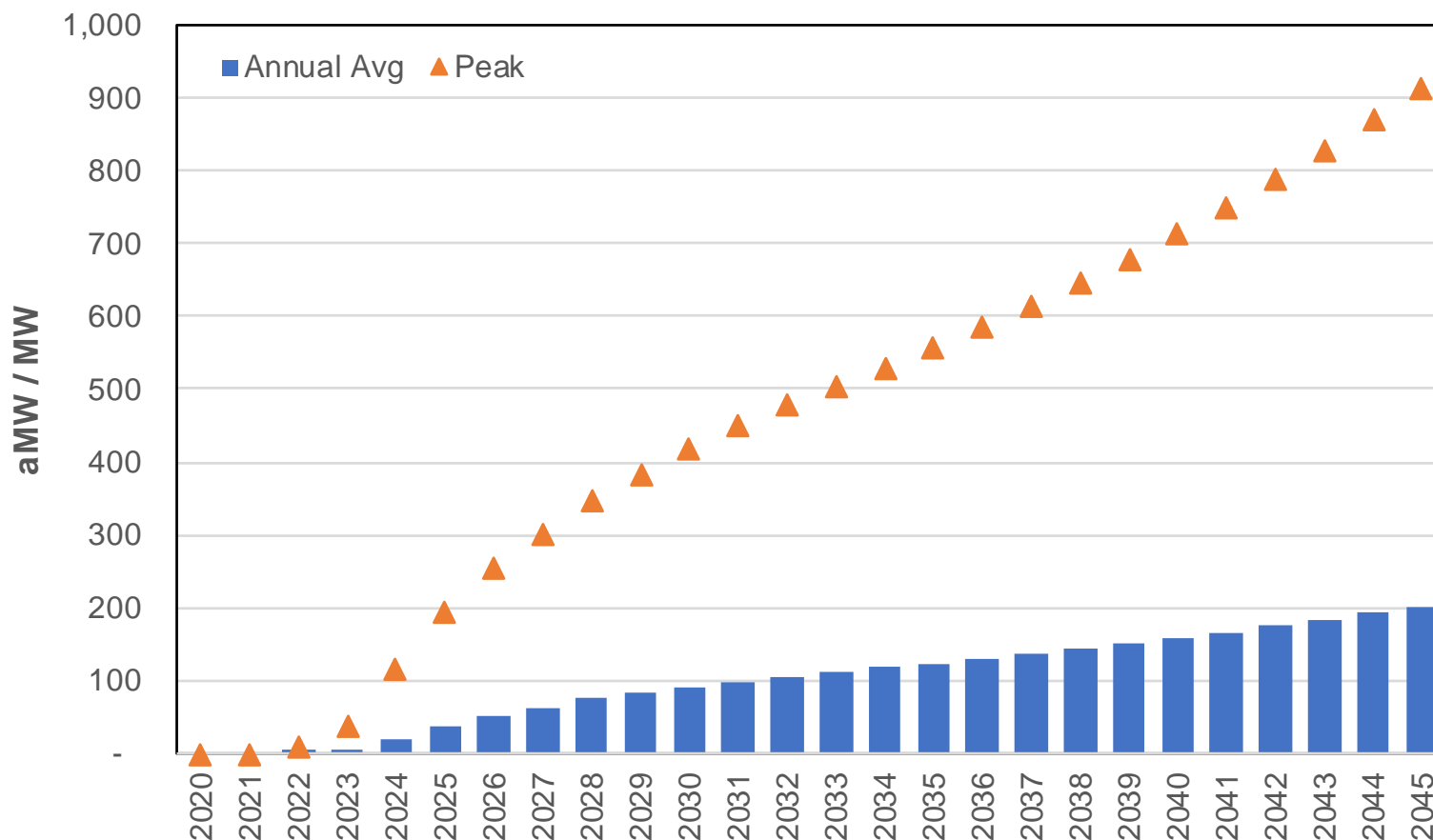

2020 IRP Forecast for 2030 absent fuel conversion:
 Peak: 1,762 MW
 Energy: 1,209 aMW



2030 Monthly Load Forecast

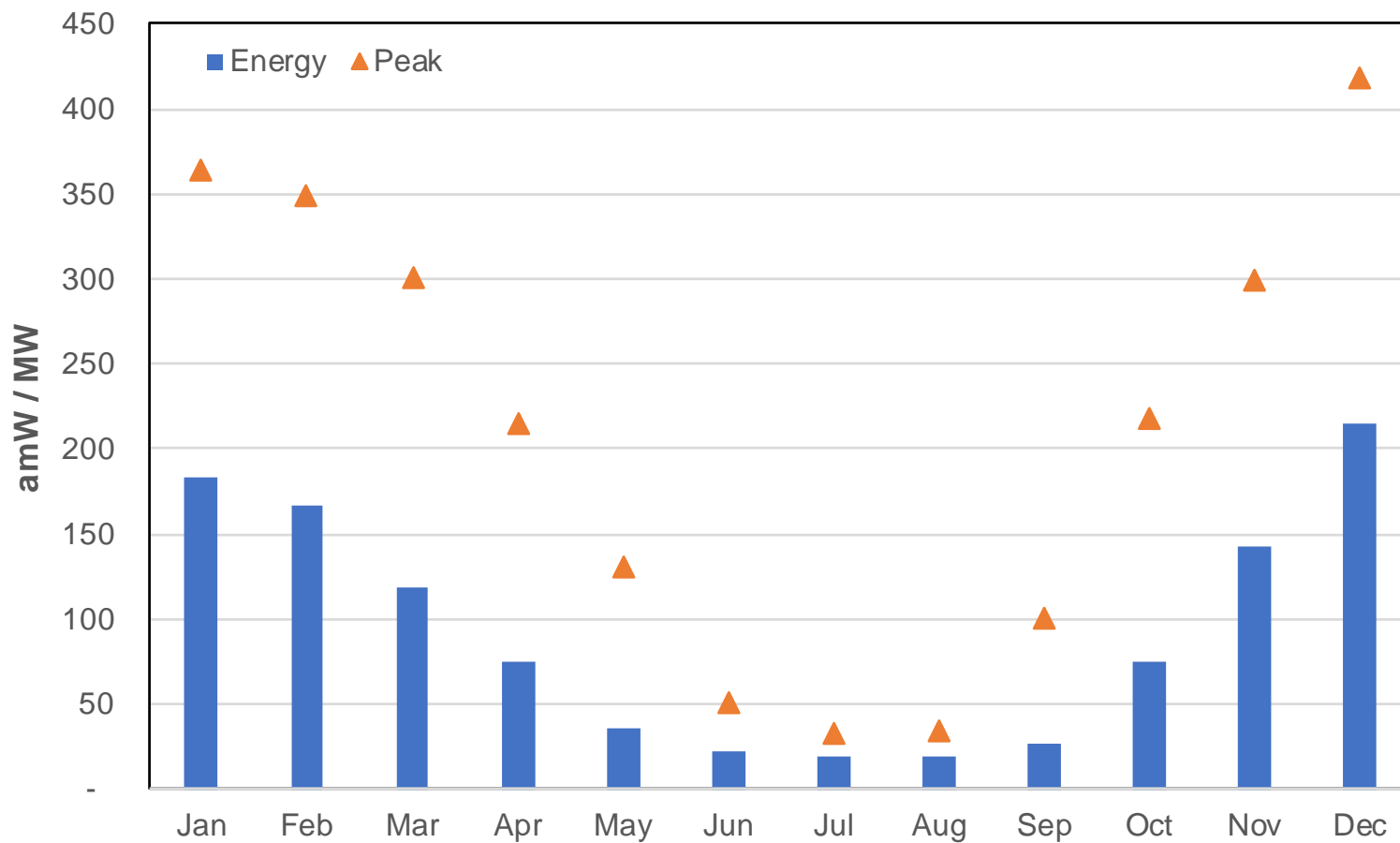

Scenario Analysis- Conversion Rates

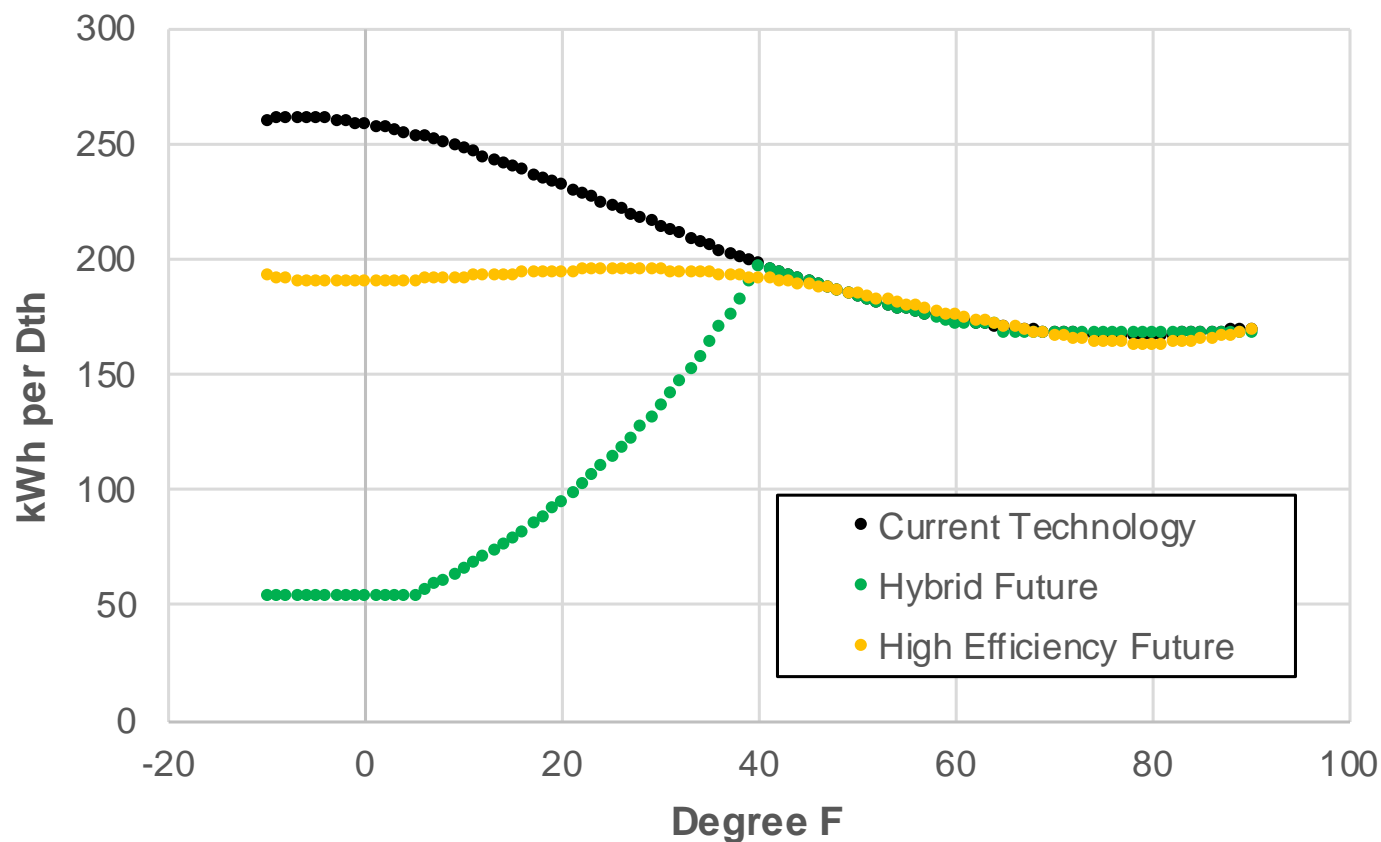

Scenario Analysis- Electric Energy

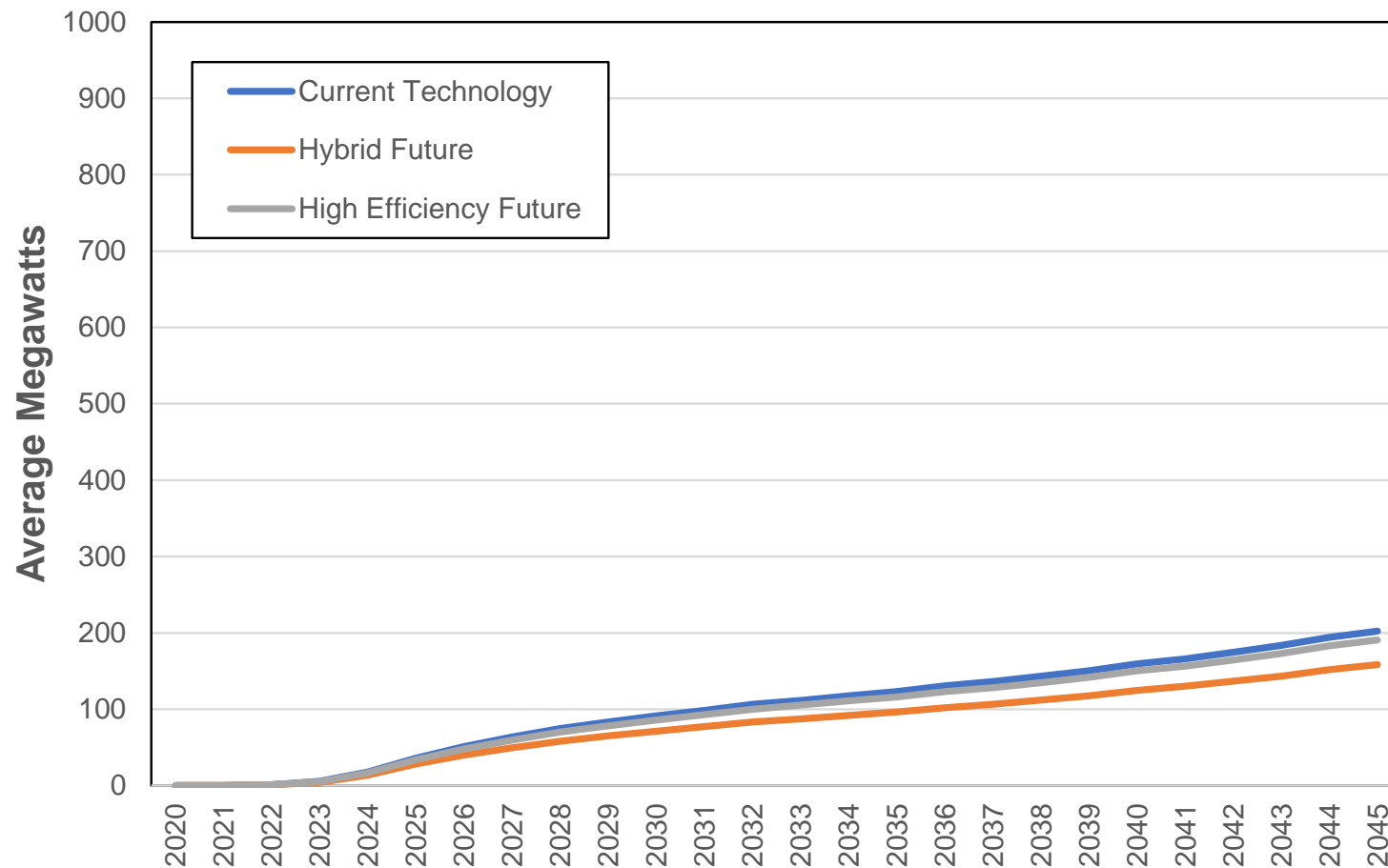

Scenario Analysis: Electric December Peak Load

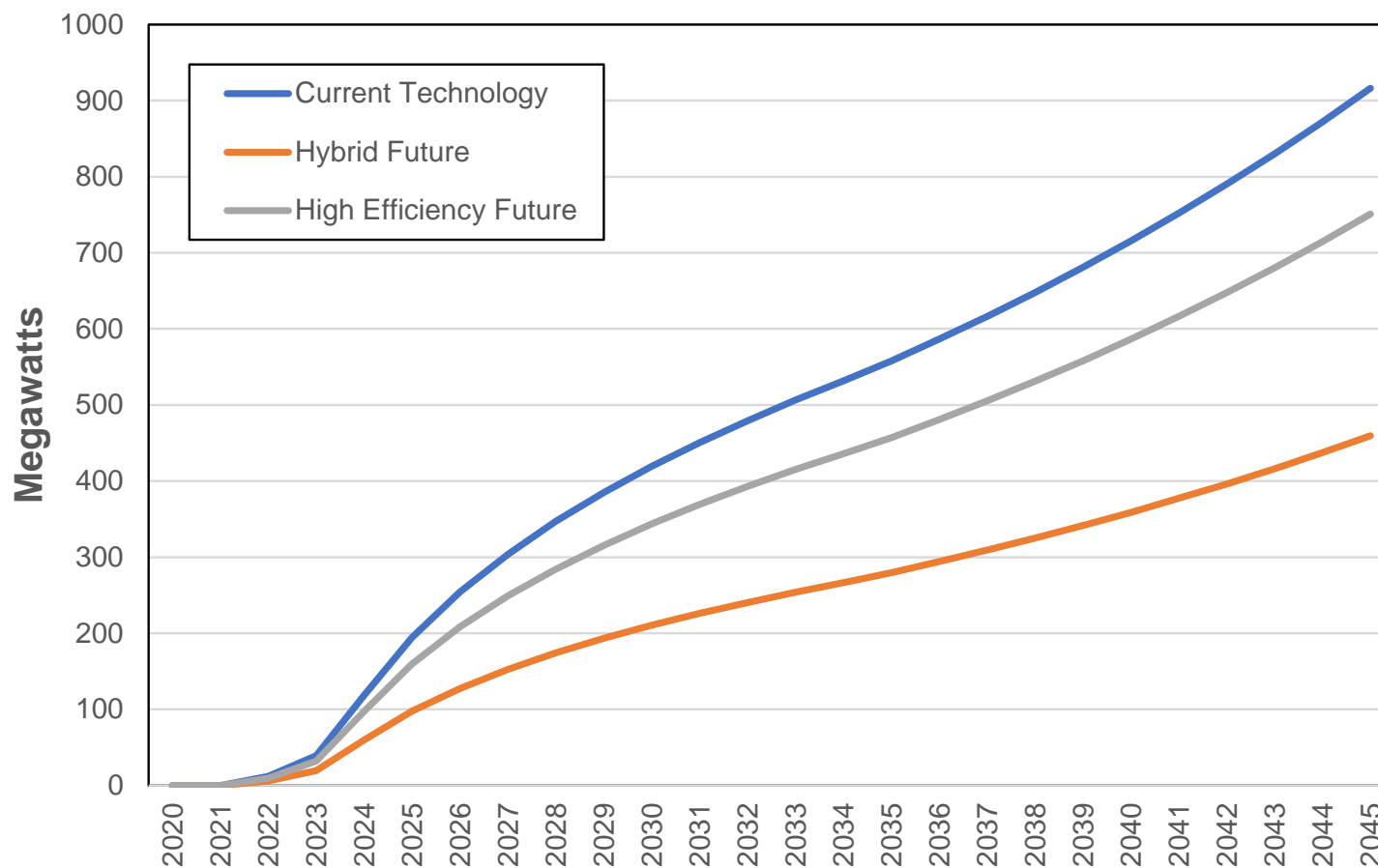

Scenario Analysis: Natural Gas Demand

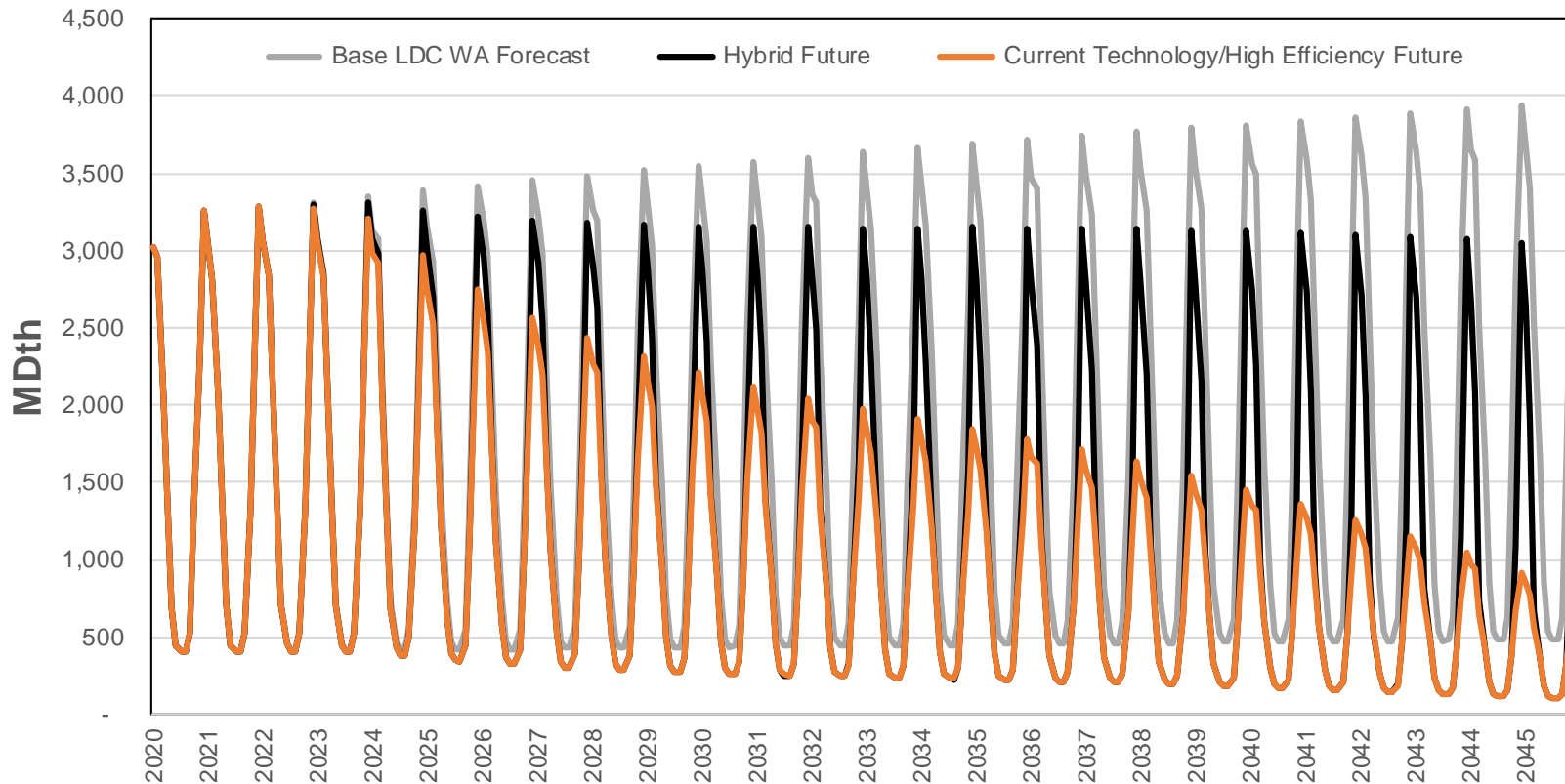

Next Steps

- Input into PRiSM model to determine resource selection and cost
 - Estimate cost meeting CETA requirements
 - Estimate cost using least cost methodology
 - Estimate emissions savings
 - Estimate \$/tonne
- Conduct electric resource adequacy study if time permits



2021 Electric IRP

Washington Vulnerable Populations & Highly Impacted Communities

James Gall, IRP Manager
Second Technical Advisory Committee Meeting
August 6, 2020

Identifying Communities or “Customers”

Highly Impacted Communities

- Cumulative Impact Analysis
- Tribal lands
 - Spokane
 - Colville
- Locations should be available by end of 2020
 - State held workshops in August & September 2019

Vulnerable Populations

- Use Washington State Health Disparities map
 - What is disproportionate on a scale of 1 to 10?
 - Avista proposes areas with a score 8 or higher in either Socioeconomic factors or Sensitive population metrics
- Should we include other metrics to identify these communities?

Environmental Health Disparities Map

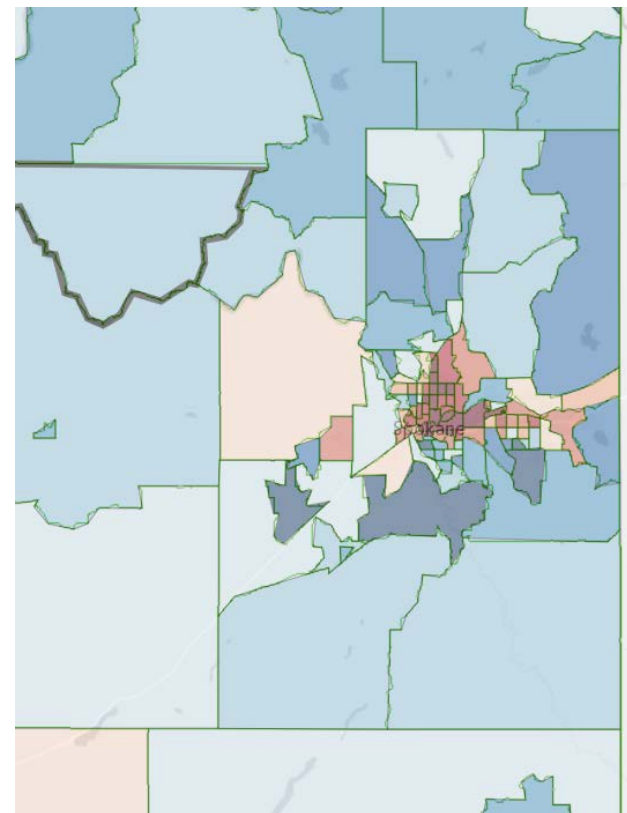
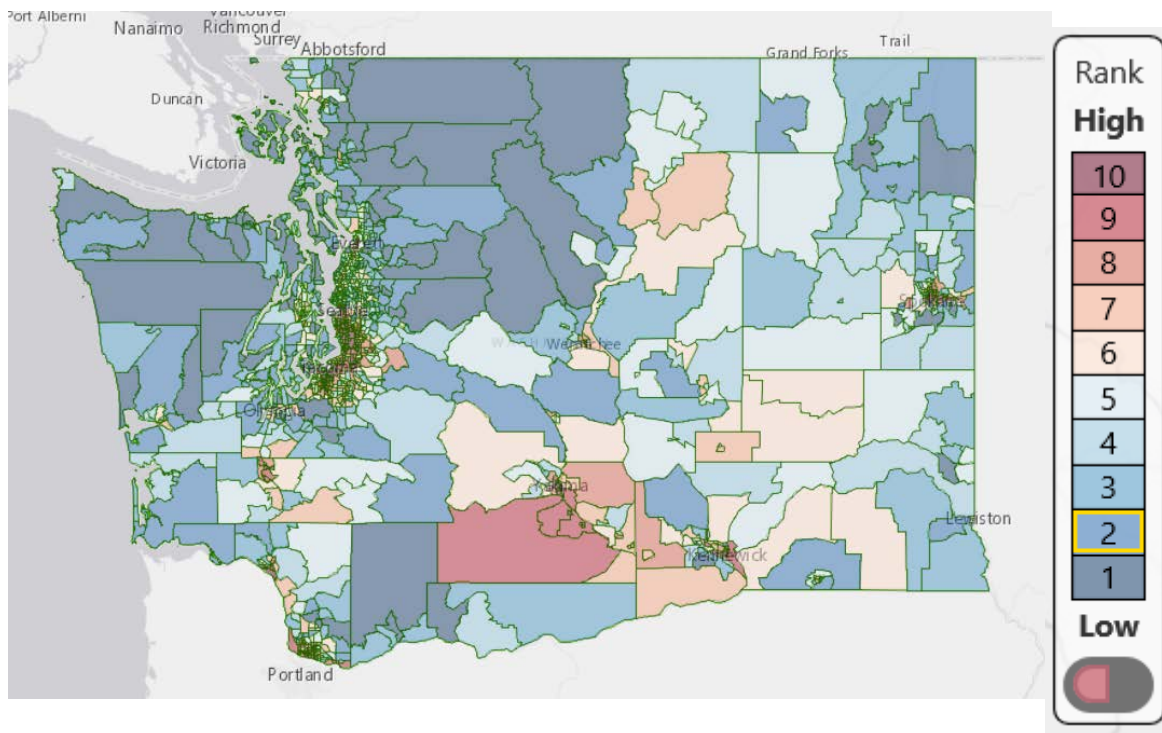

<https://fortress.wa.gov/doh/wtn/wtnibl/>

Department of Health data is divided up by Federal Information Processing Standards (FIPS) Code

Environmental Health Scoring

From WA Department of Health

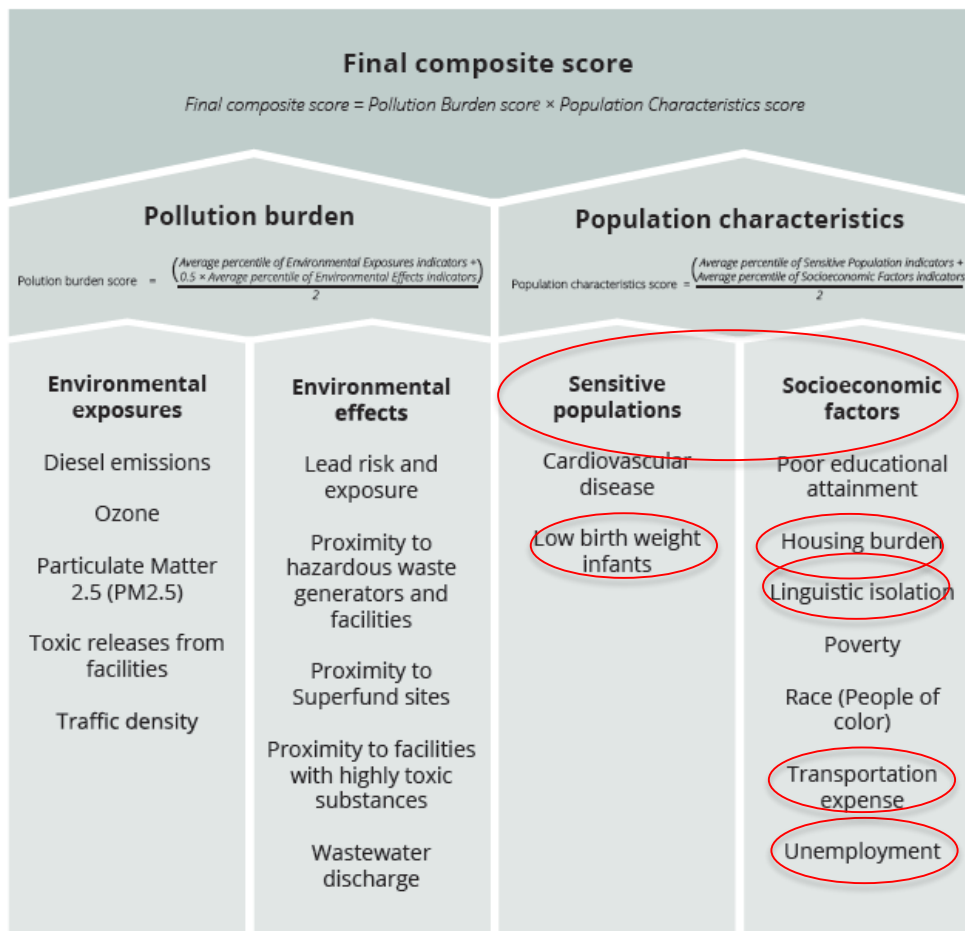

Circle areas match definition of vulnerable population, although access to food & health care, higher rates of hospitalization are not expressively included but are an indication of poverty

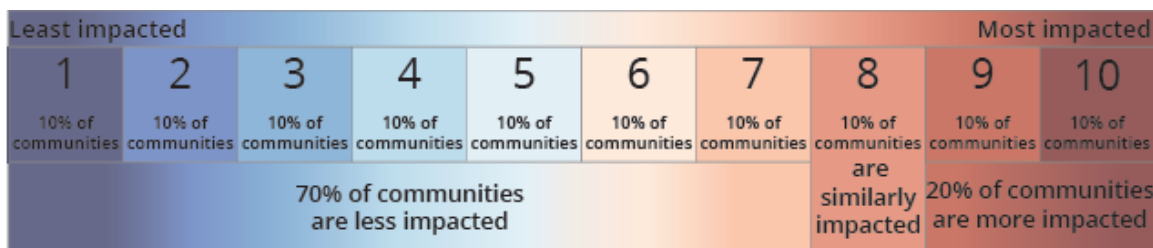

Selected Vulnerable Populations

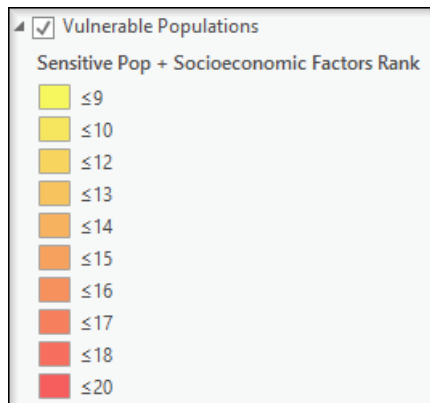

Data is shown by combined score

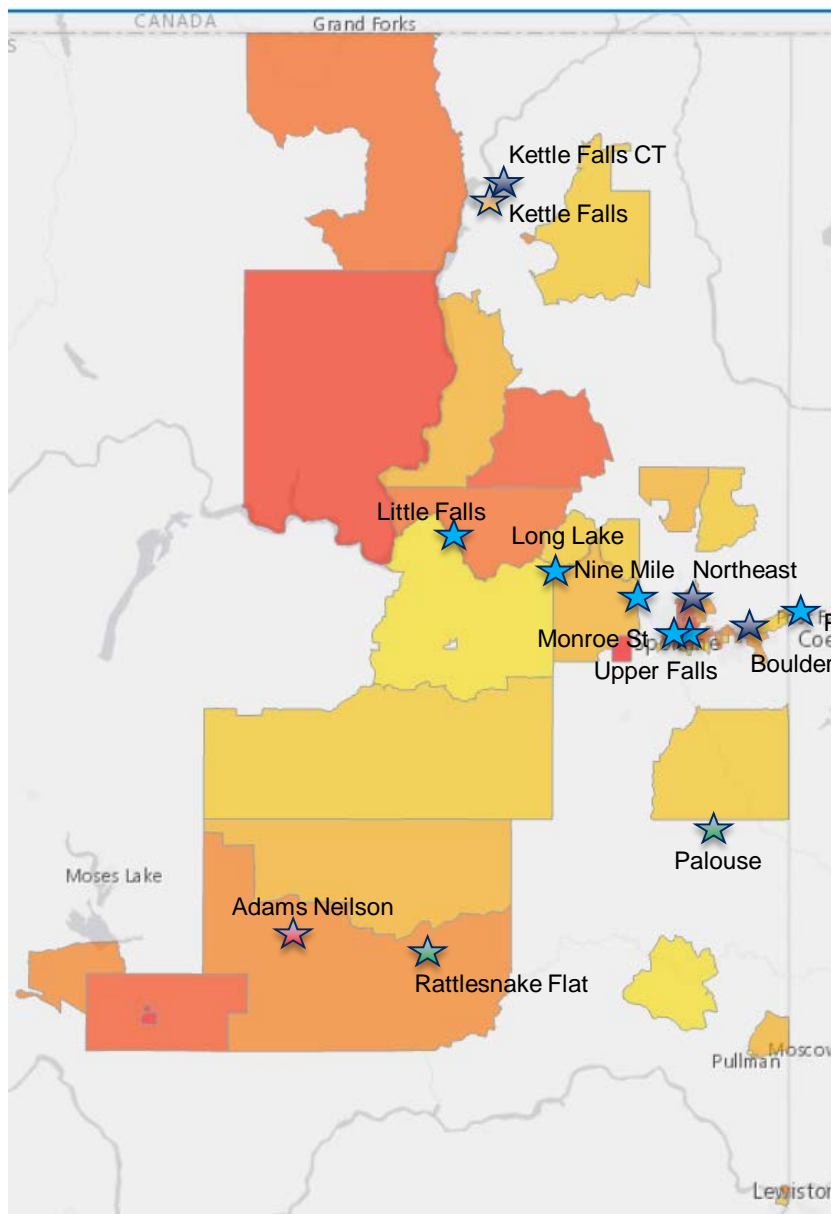

“Large” Resource Legend

- Natural Gas
- Biomass
- Hydro
- Wind
- Solar



Spokane Area "Avista" Vulnerable Populations

- ★ Natural Gas
- ★ Biomass/Other
- ★ Hydro
- ★ Wind
- ★ Solar

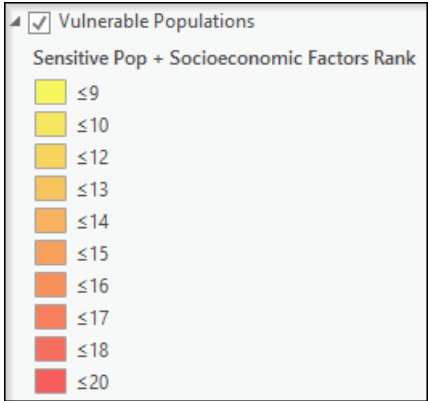

Data is shown by combined score

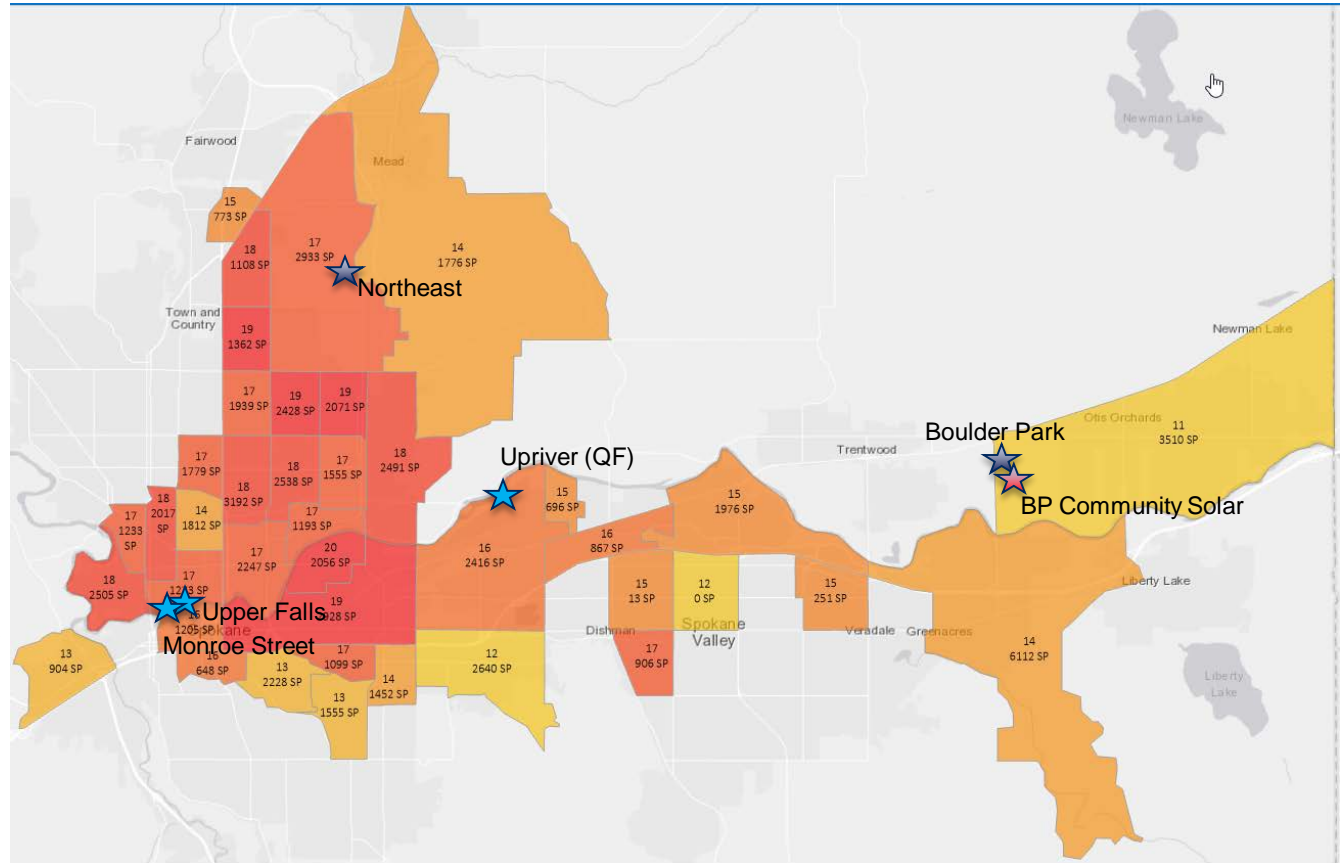

★ Waste-to-Energy (QF)

IRP Metrics *(From Last TAC Meeting)*

Metric	IRP Relationship
Energy Usage per Customer	<ul style="list-style-type: none"> • Expected change taking into account selected energy efficiency then compare to remaining population. • EE includes low income programs and TRC based analysis which includes non-economic benefits.
Cost per Customer	<ul style="list-style-type: none"> • Estimate cost per customer then compare to remaining population. • How do IRP results compare to above 6% of income?
Preference	<ul style="list-style-type: none"> • Should the IRP have a monetary preference? <ul style="list-style-type: none"> • For example- should all customers pay more to locate assets (or programs) in areas with vulnerable populations or highly impacted communities? • If so, how much more?

IRP Metrics *(From Last TAC Meeting)*

Metric	IRP Relationship
Reliability <ul style="list-style-type: none"> • SAIFI: System Average Interruption Frequency Index • MAIFI: Momentary Average Interruption Frequency Index 	<ul style="list-style-type: none"> • Calculate baseline for each distribution feeder and match with communities • Estimate benefits for area with potential IRP distribution projects
Resiliency: <ul style="list-style-type: none"> • SAIDI: System Average Interruption Duration Index • CAIDI: Customer Average Interruption Duration Index • CELID: Customer's Experiencing Long Duration Outages 	<ul style="list-style-type: none"> • Compare to other communities as baseline • May be more appropriate in Distribution plan rather than IRP
Resource Analysis	<ul style="list-style-type: none"> • Estimate emissions (NO_x, SO₂, PM2.5, Hg) from power projects located in/near identified communities • Identify new resource or infrastructure project candidates with benefit to communities; i.e. economic benefit, reliability benefit • Identify how resource can benefit energy security

Energy Use Analysis Results

- Uses five years of customer billing data
- Median income over the same period is used to estimate affordability
- Separated electric only vs electric/gas customers
 - Future enhancement include single/multi family homes, and manufactured homes

Energy/Cost Analysis

Electric Only Customers

Area	Fuel Type	Energy Use	Avg Bill	Income	% Income
Vulnerable Population Areas	Electric	998 KWh	\$98	\$42,730	2.8%
Other Areas	Electric	1,010 KWh	\$100	\$58,834	2.0%

Note: Mean energy use is statistically significantly different when removing energy use data below 100 kWh per month (1,049 kWh vs 1,082 kWh)

Natural Gas/Electric Customers

Area	Fuel Type	Energy Use	Avg Bill	Income	% Income
Vulnerable Population Areas	Electric	820 KWh	\$80		
Other Areas	Electric	875 KWh	\$84		
Vulnerable Population Areas	Gas	52 Therms	\$47	\$44,889	3.4%
Other Areas	Gas	62 Therms	\$56	\$68,250	2.5%

Note: Combined natural gas/electric homes have higher energy burden due to fewer multifamily homes included in the population or all electric home including homes with alternative heat such as wood, propane, oil, pellets. Future analysis needed to validate this hypothesis.

Vulnerable Populations

Electric Only Customers- Energy % of Income

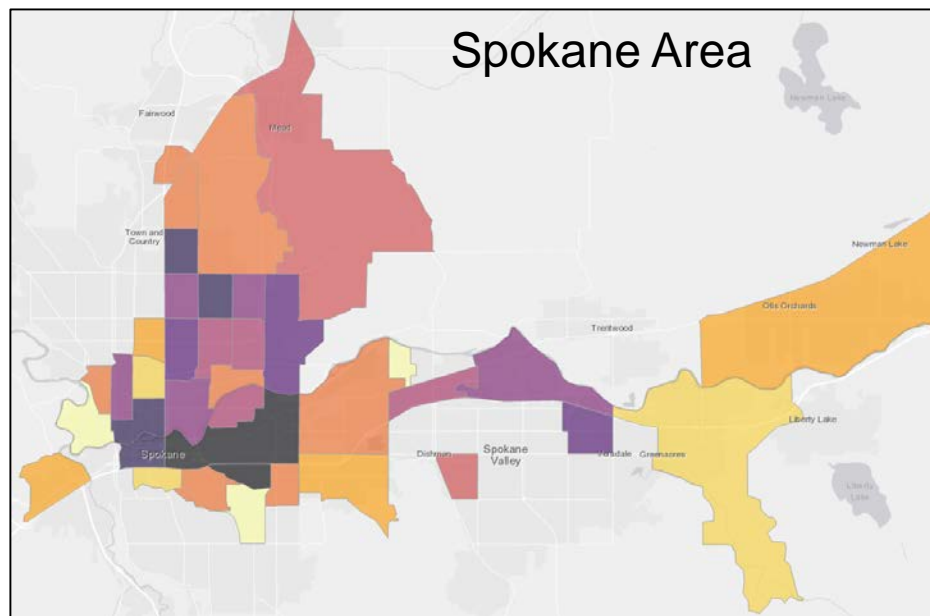
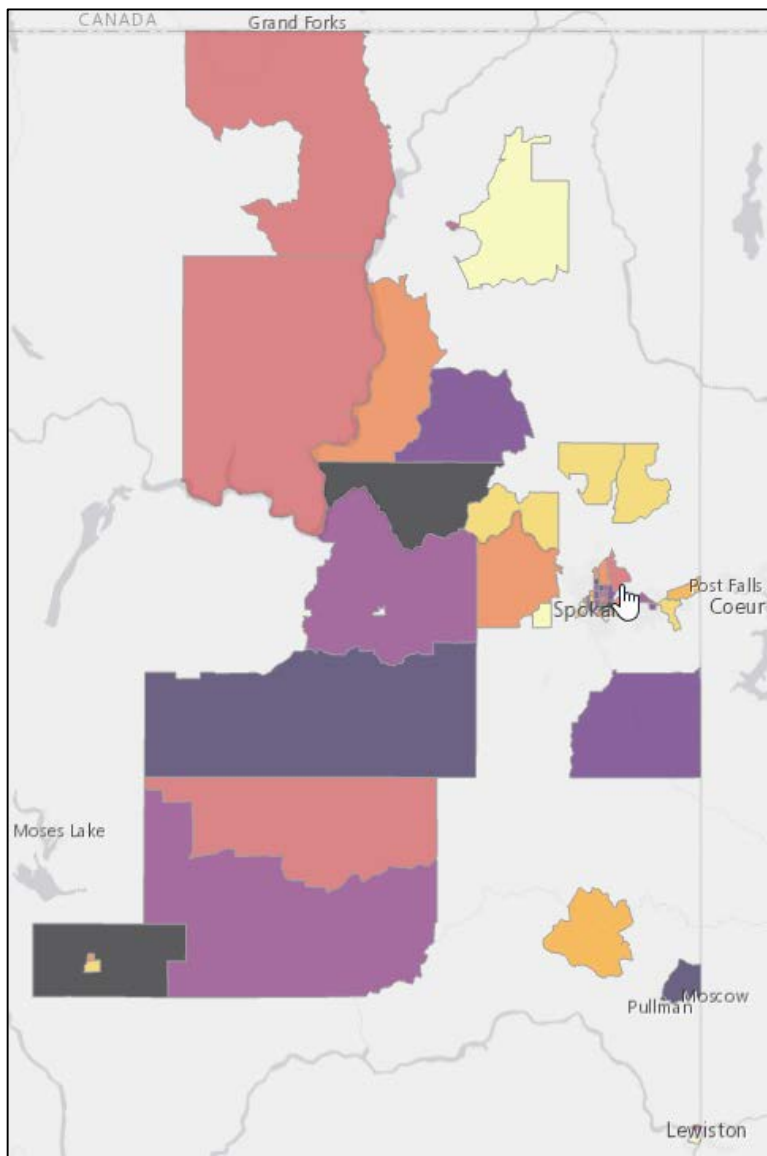

Energy Cost as % of Income - Electric Only

5 Year Avg for Electric Only Customers

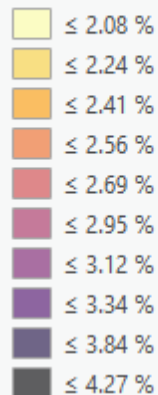

Vulnerable Populations

Gas/Electric Only Customers- Energy % of Income

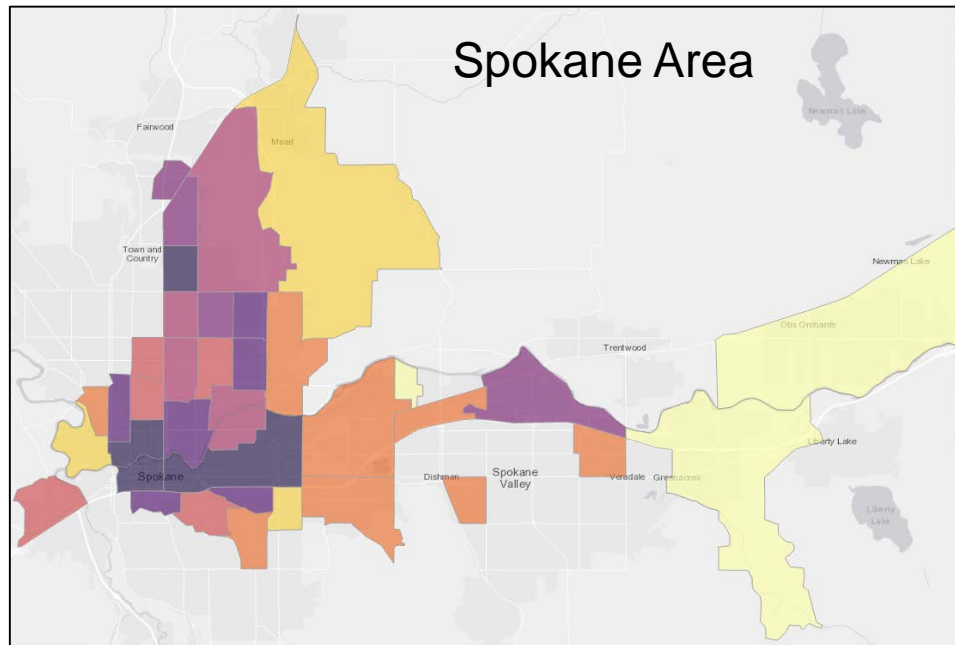
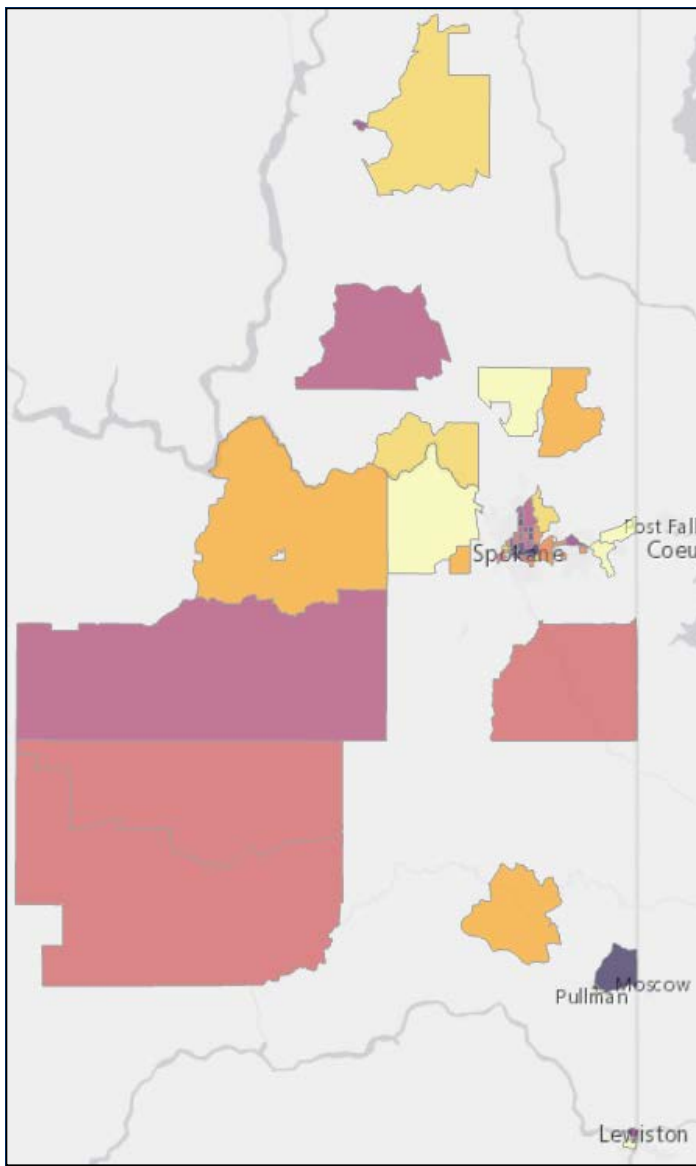

Energy Cost as % of Income - Electric & Gas

5 Year Avg for Customers with Both

- ≤ 2.64 %
- ≤ 2.81 %
- ≤ 3.04 %
- ≤ 3.32 %
- ≤ 3.66 %
- ≤ 4.01 %
- ≤ 4.49 %
- ≤ 5.10 %
- ≤ 7.92 %
- ≤ 11.07 %



Reliability Data- CAIDI

Measure of resilience- minutes of outages per event
Excludes Major Event Days (MED)

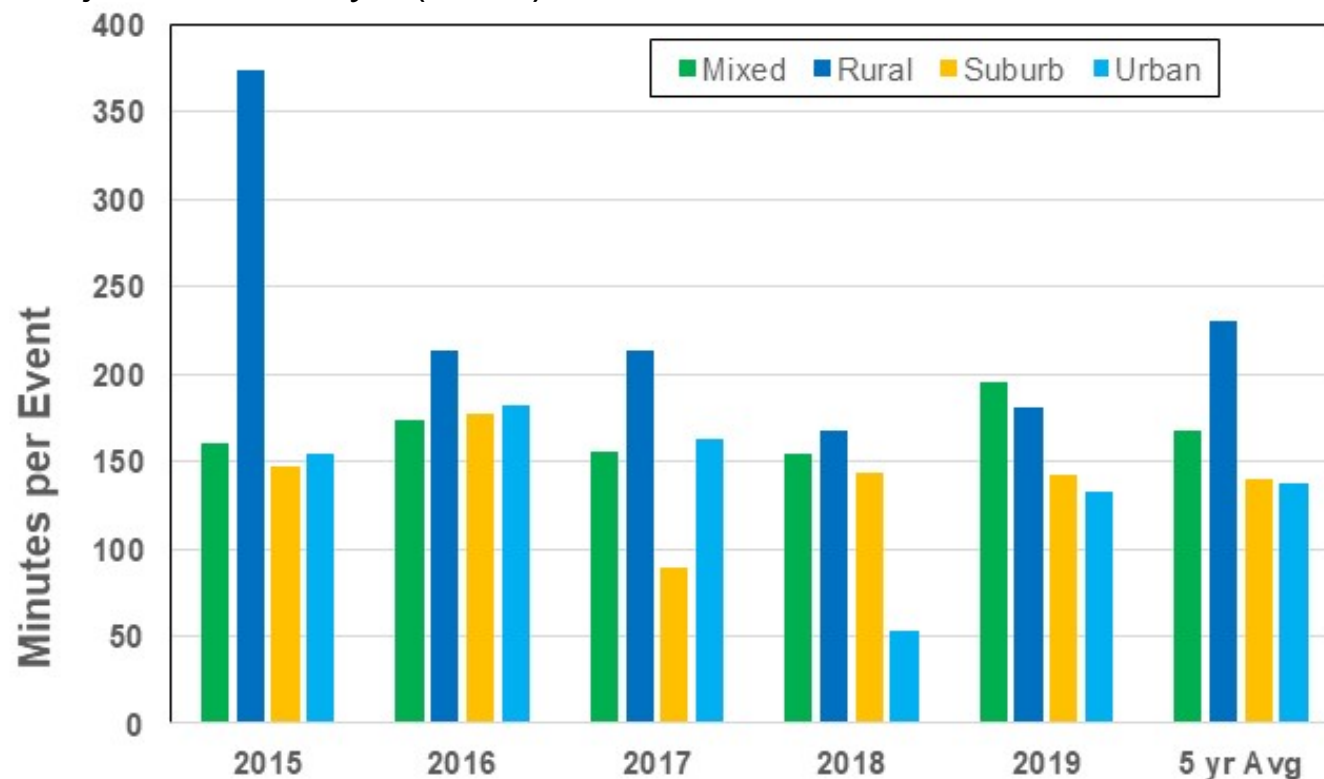

Reliability Data- CEMI

Measure of reliability- Events per Customer

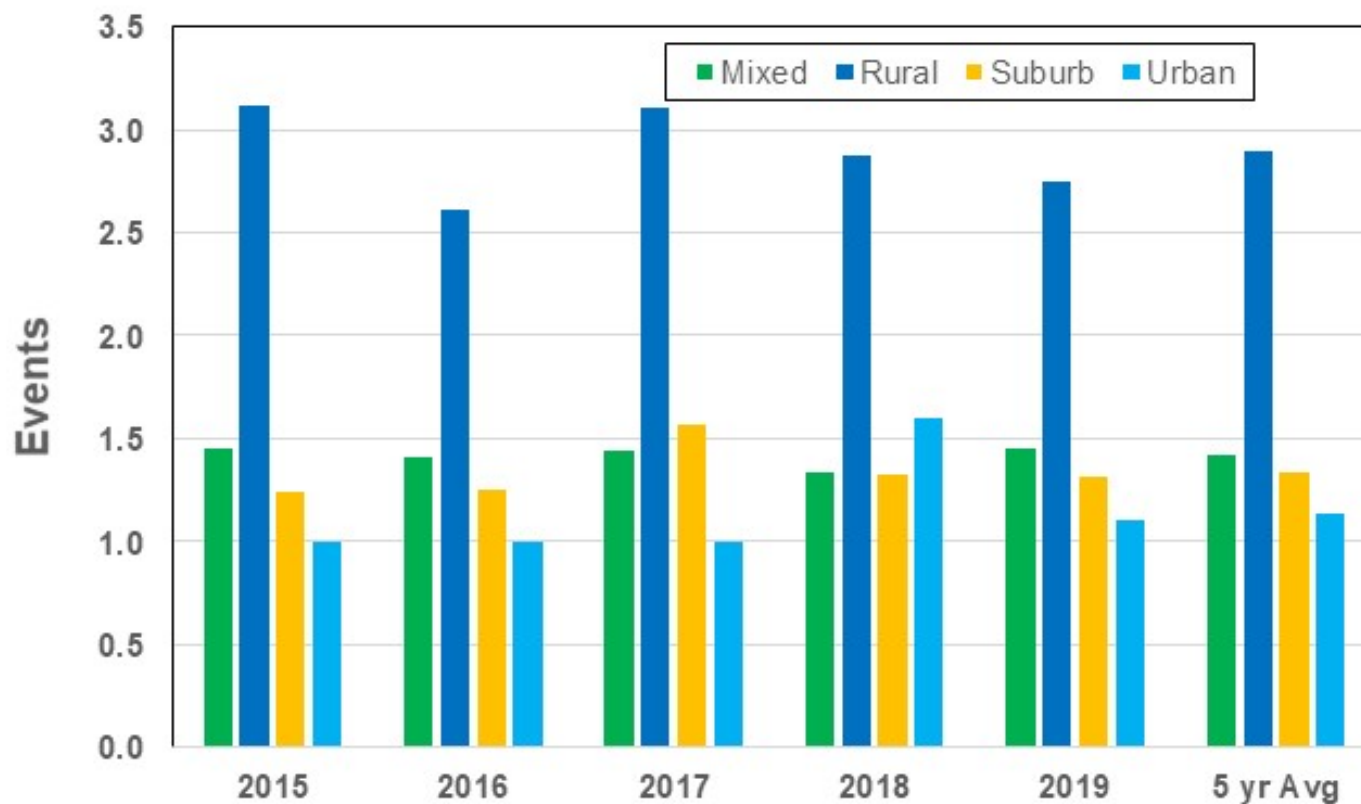

Vulnerable Area vs Non Vulnerable Areas

CAIDI

CEMI

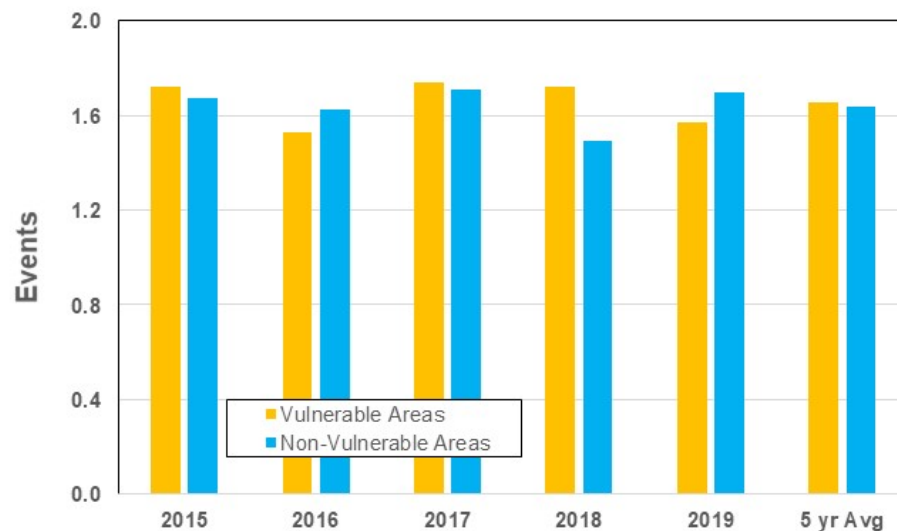
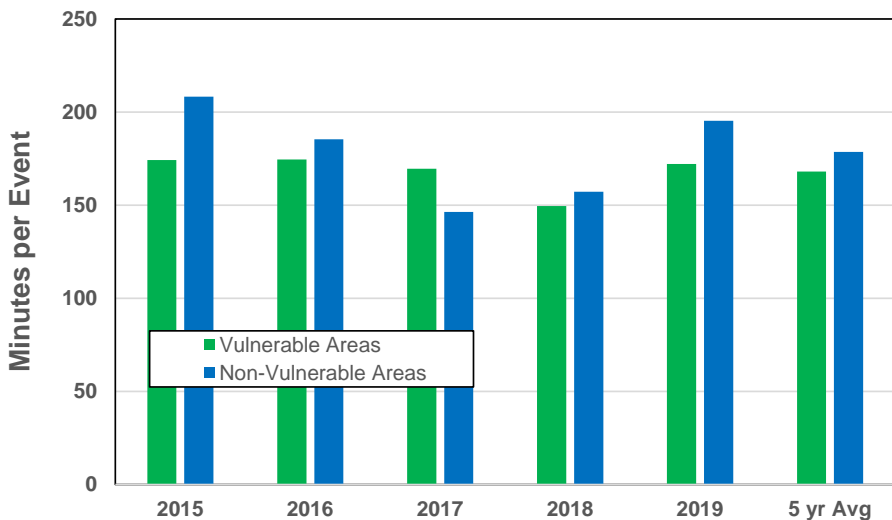

Note: 5 yr Average differences are statistically significantly different

CAIDI- By Feeder Type

Mixed Feeders

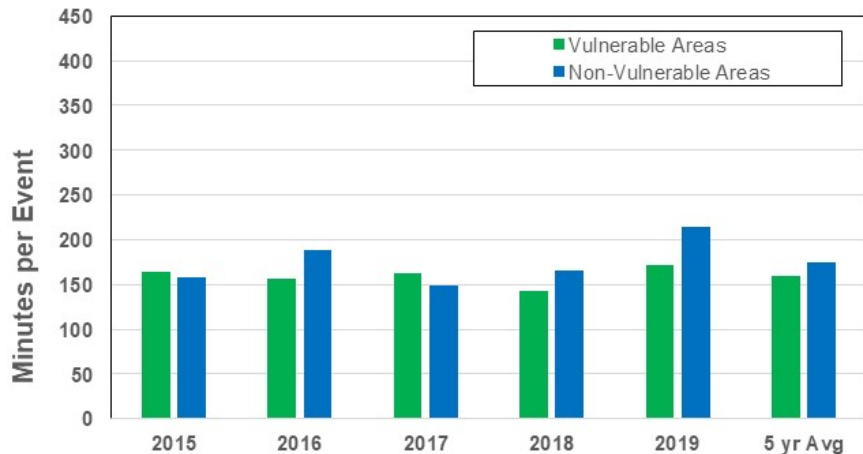

Rural Feeders

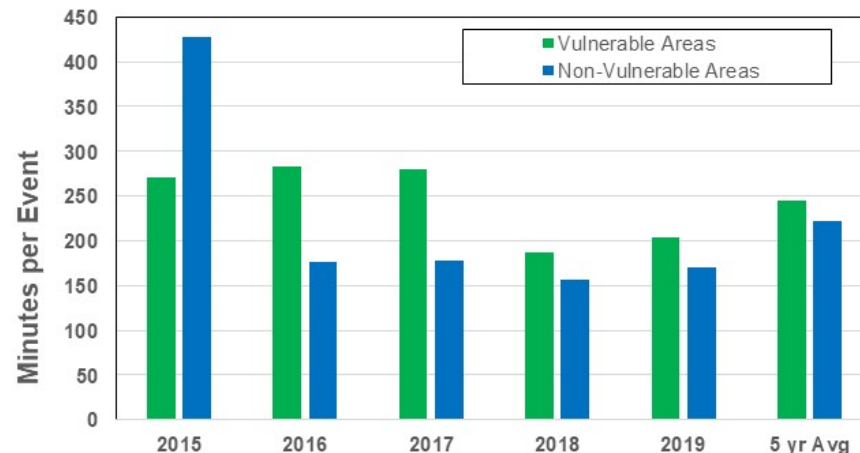

Suburban Feeders

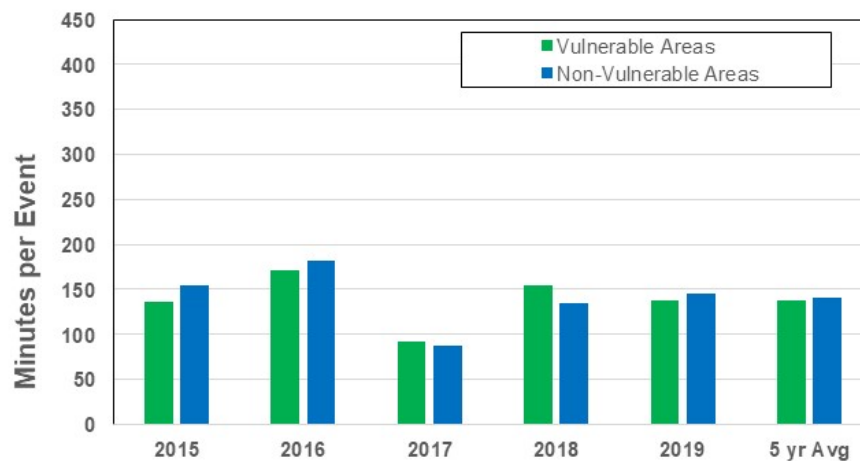

Note: Avista has no vulnerable areas with urban feeders



CEMI- By Feeder Type

Mixed Feeders

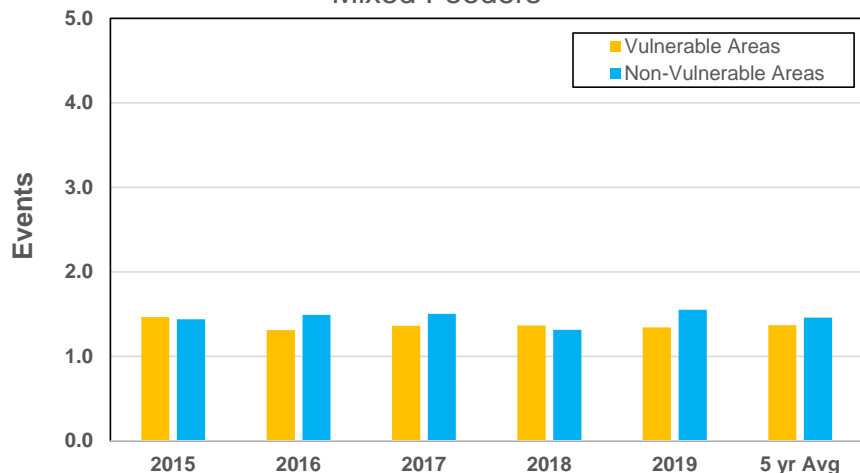

Rural Feeders

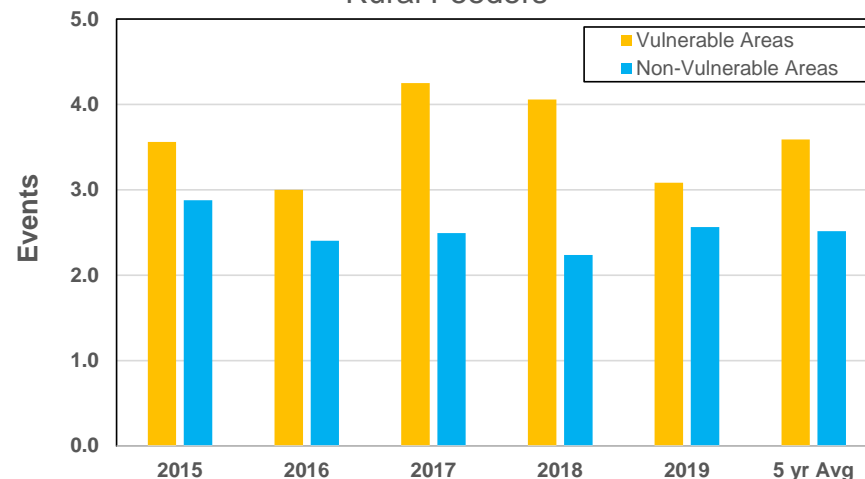

Suburban Feeders

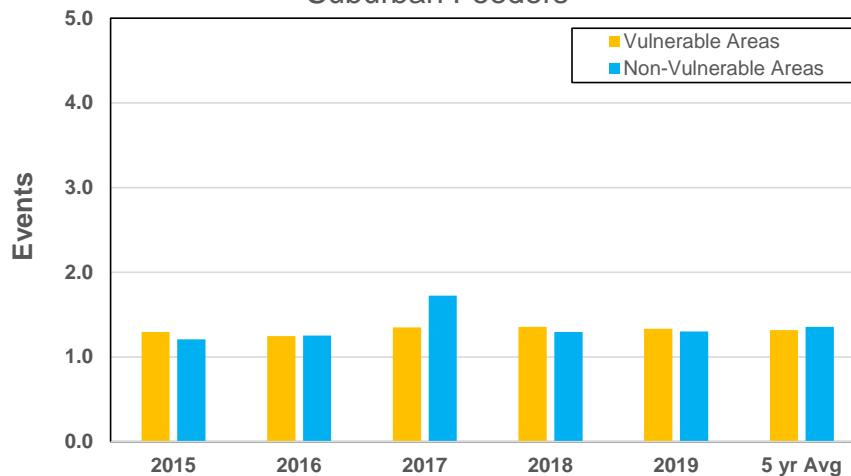

Note: Avista has no vulnerable areas with urban feeders

Avista's Washington Power Plant Air Emissions

Washington SO2 Emissions

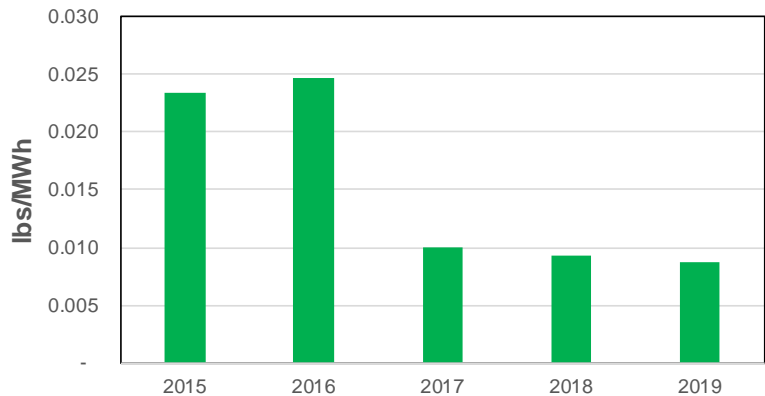

Washington NOx Emissions

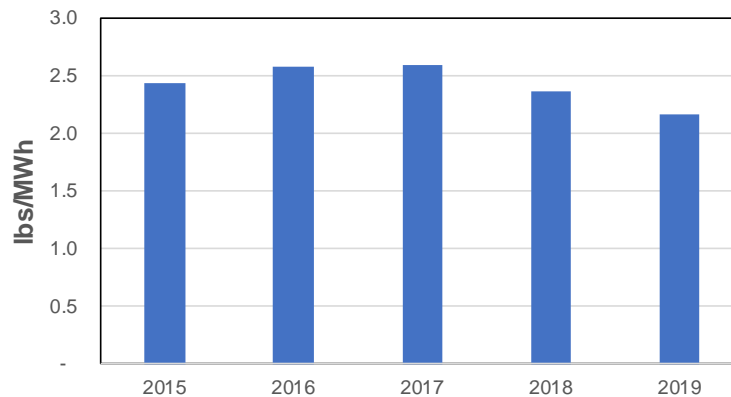

Washington Hg Emissions

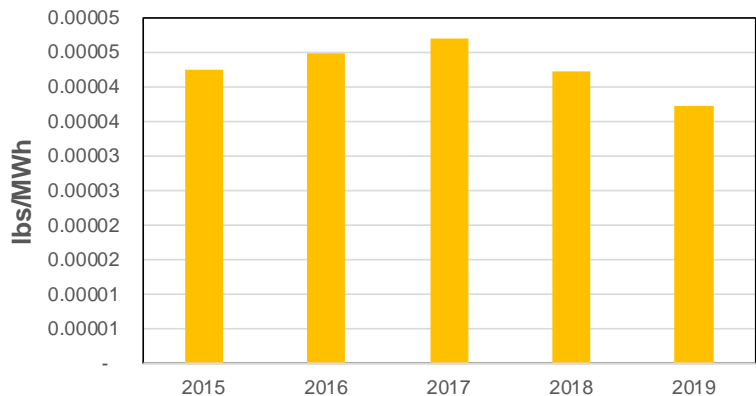

Washington VOC Emissions

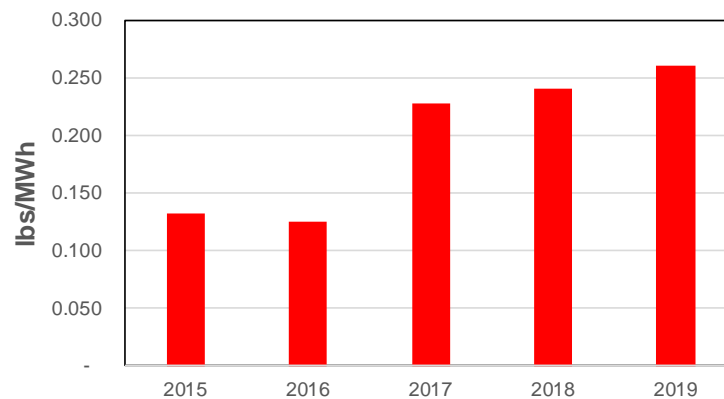

TAC Input

- What other metrics can we provide in an IRP to show vulnerable populations and highly impacted communities are not harmed by the transition to clean energy



Economic, Load, and Customer Forecasts

Grant D. Forsyth, Ph.D.
Chief Economist
Technical Advisory Committee Meeting
August 18, 2020

Main Topic Areas

- **Service Area Economy**
- **Long-run Energy Forecast**
- **Peak Load Forecast**
- **Long-run Gas Customer Forecast**





Service Area Economy

Grant D. Forsyth, Ph.D.
Chief Economist
Grant.Forsyth@avistacorp.com

Distribution of Employment, 2019

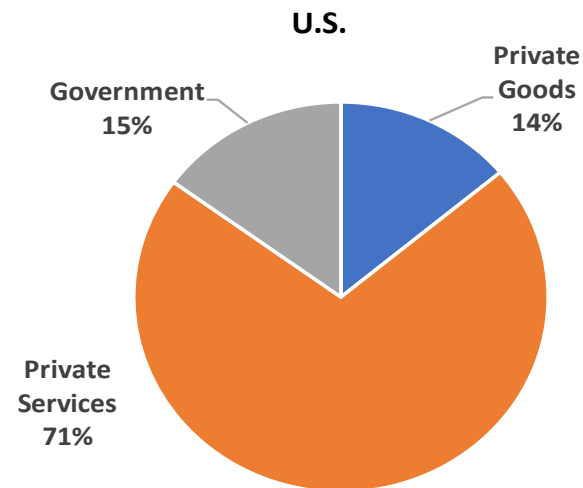
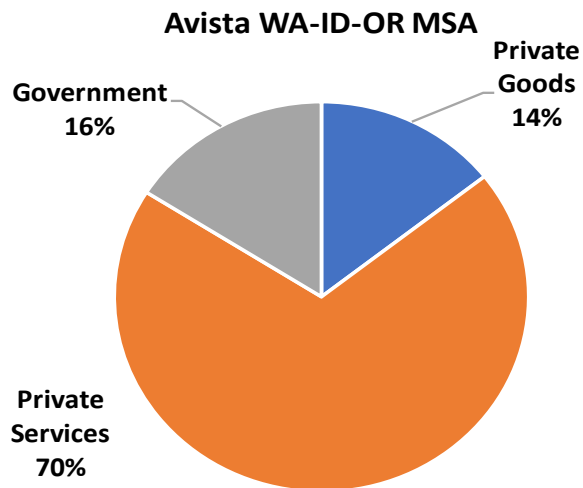

Avista WA-ID-OR MSA Government

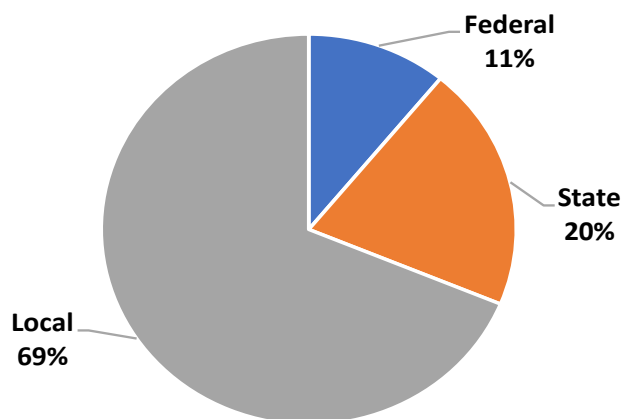

U.S. Government

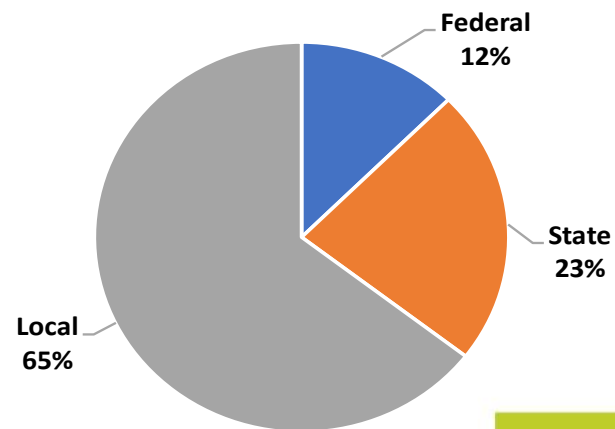

Source: BLS and author's calculations.

Non-Farm Employment Growth, 2009-2020

Non-Farm Employment Growth (Dashed Shaded Box = Recession Period)

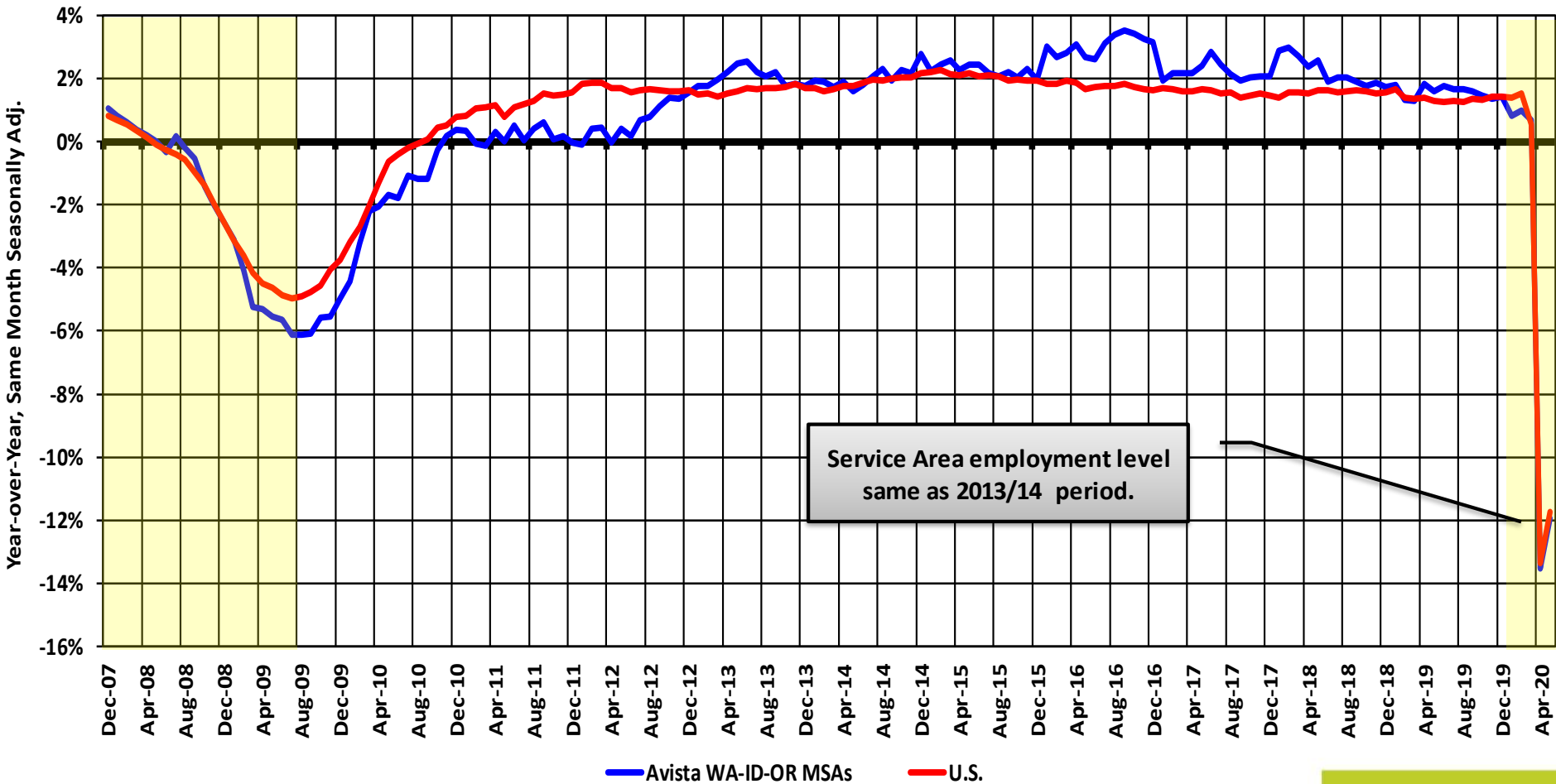

Source: BLS, WA ESD, OR ED and author's calculations.



MSA Population Growth, 2007-2019

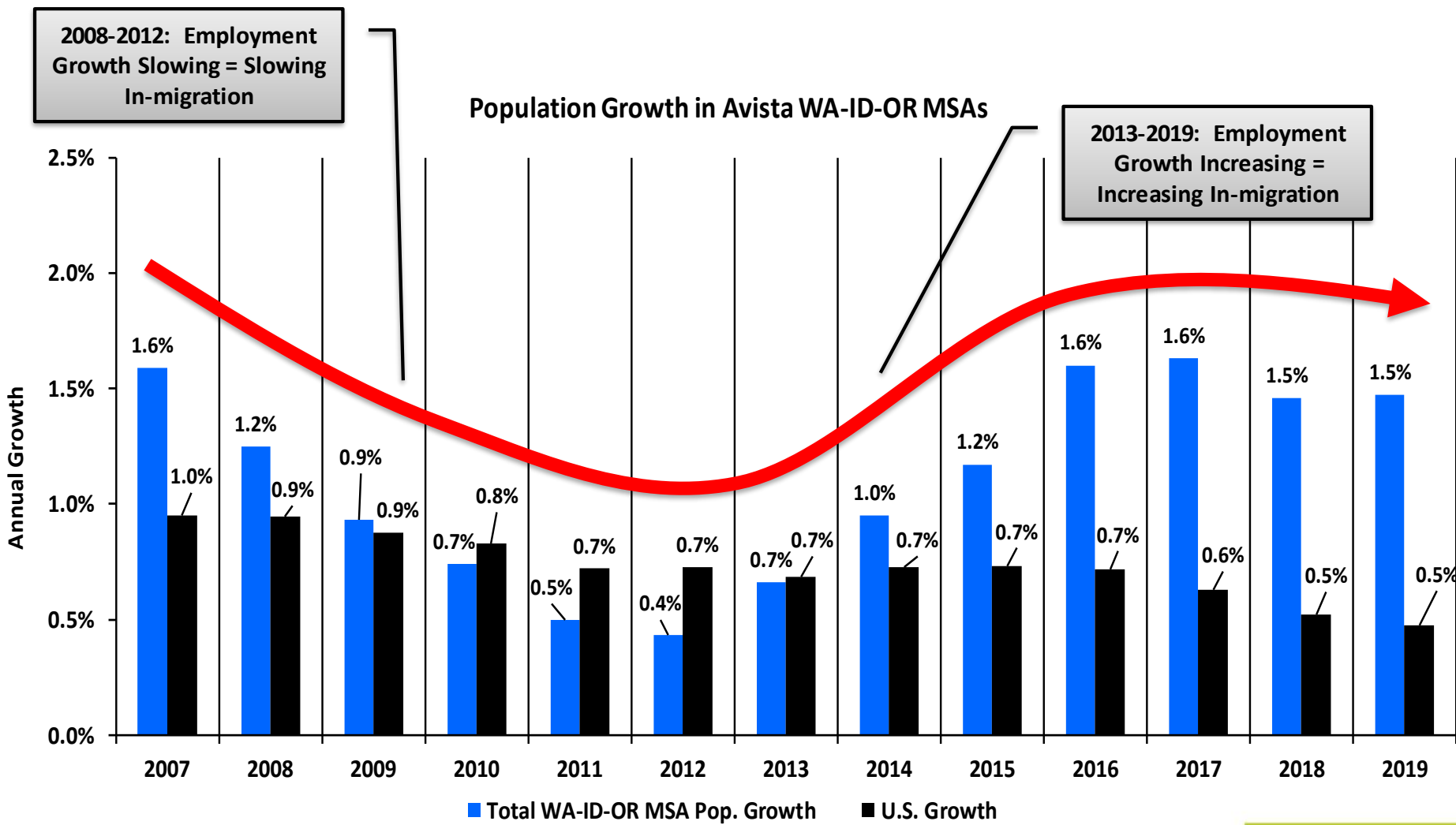

Source: BEA, U.S. Census, and author's calculations.



GDP Growth Assumptions: 2021 IRP vs. 2020 IRP

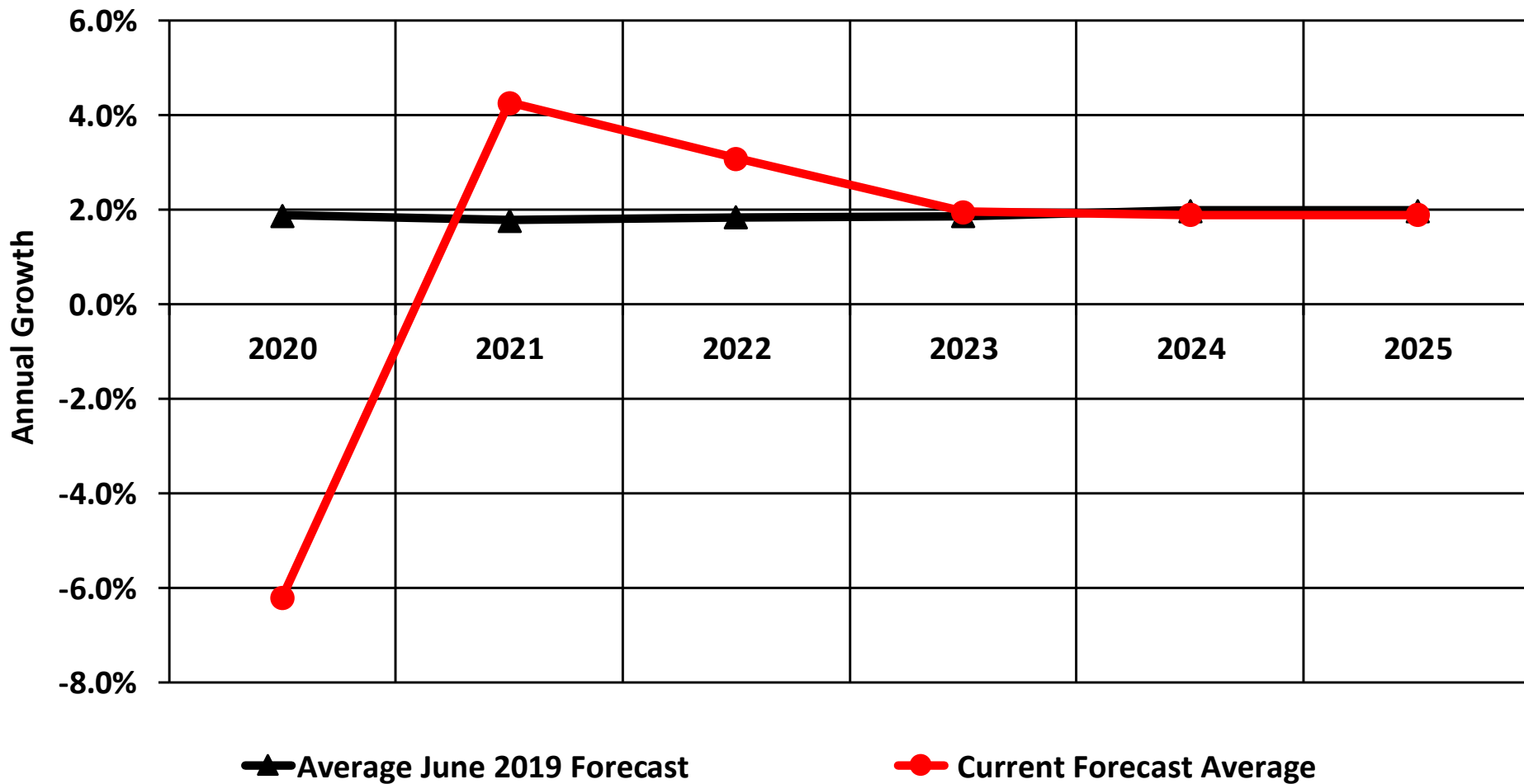

Source: Various and author's calculations.



Long-Term Energy Load Forecast

Grant D. Forsyth, Ph.D.
Chief Economist
Grant.Forsyth@avistacorp.com

Basic Forecast Approach

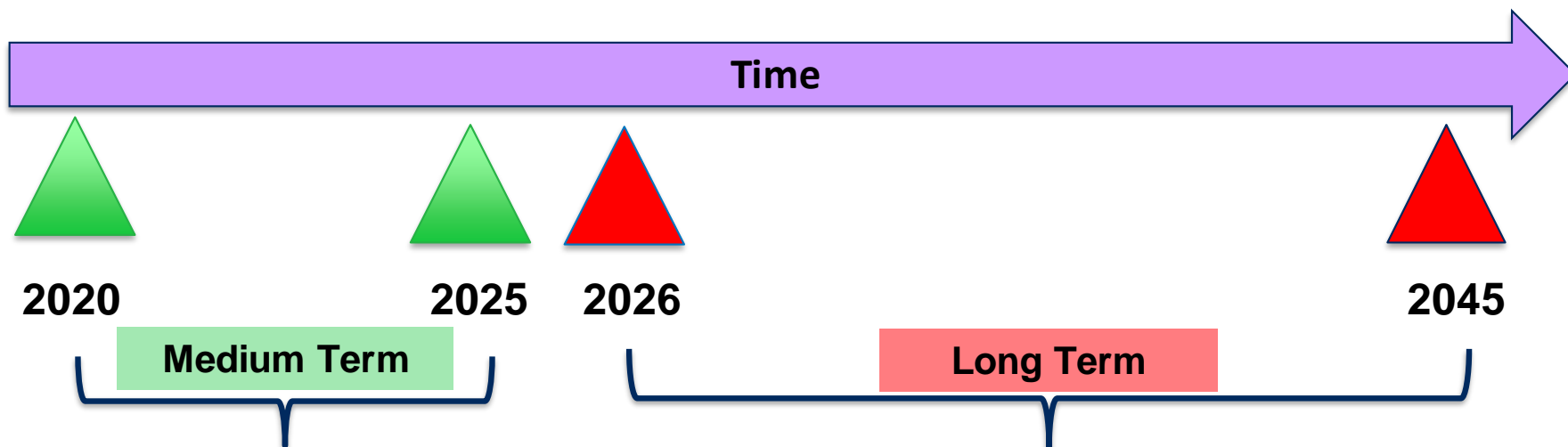

- 1) Monthly econometric model by schedule for each class.
- 2) Customer and UPC forecasts.
- 3) 20-year moving average for "normal weather."
- 4) Economic drivers: GDP, industrial production, employment growth, population, price, natural gas penetration, and ARIMA error correction.
- 5) Native load (energy) forecast derived from retail load forecast.
- 6) Current forecast is the "Summer/Fall Forecast" done in June.

- 1) Boot strap off medium term forecast.
- 2) Apply long-run load growth relationships to develop simulation model for high/low scenarios.
- 3) Include different scenarios for renewable penetration with controls for price elasticity, EV/PHEVs, and natural gas penetration.

The Long-Term Relationship, 2021-2045

Load = Customers X Use Per Customer (UPC)

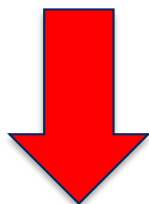

Load Growth \approx Customer Growth + UPC Growth

Assumed to be same as population growth for residential after 2025, commercial growth will follow residential, and slow decline in industrial.

Assumed to be a function of multiple factors including renewable penetration, gas penetration, and EVs/PHEVs.

Residential Customer Growth, 2020-2045

Annual Residential Customer Growth Rates

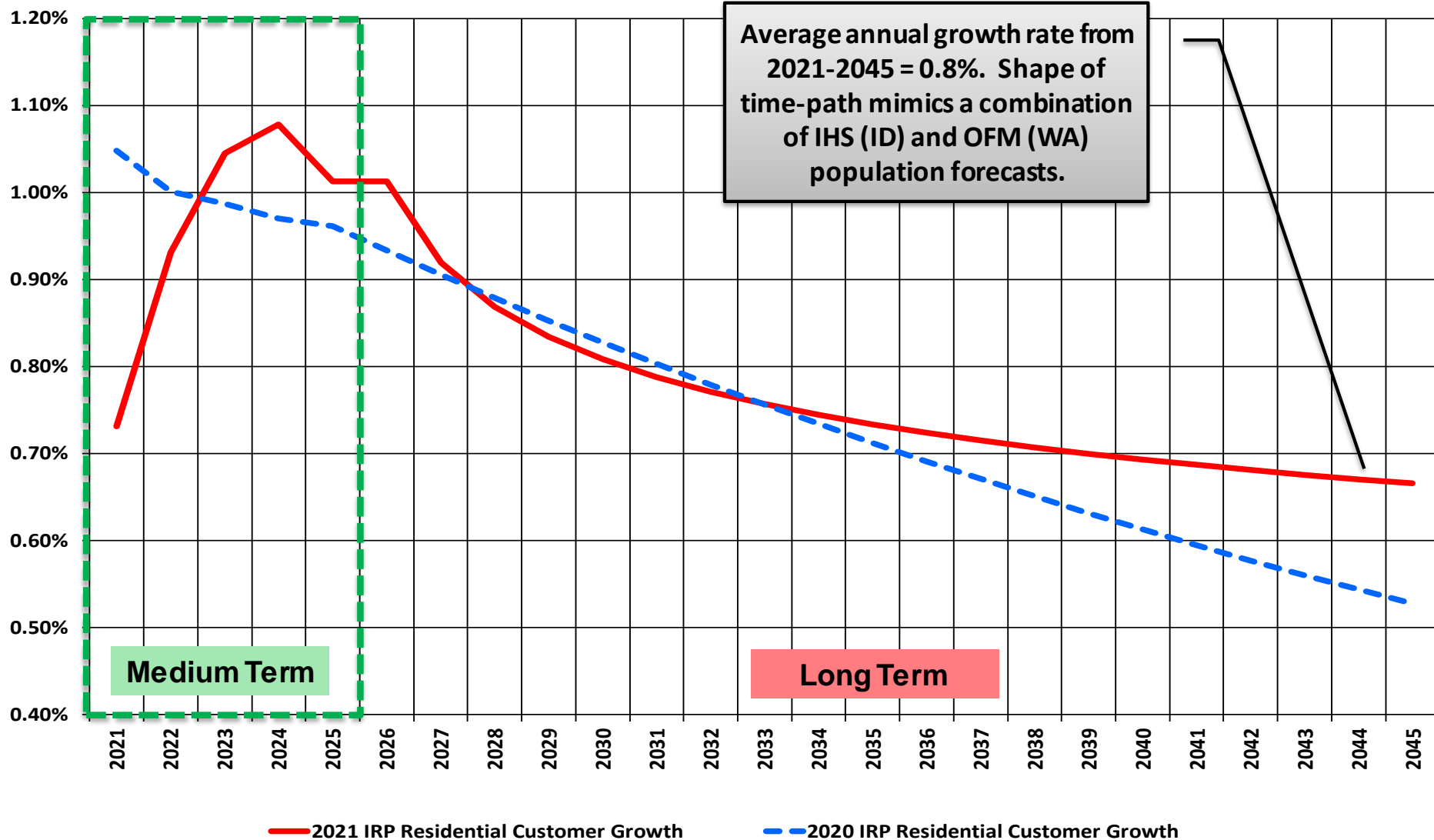

Residential Solar Penetration, 2008-2019

Customer Penetration vs. Customers Since 2008

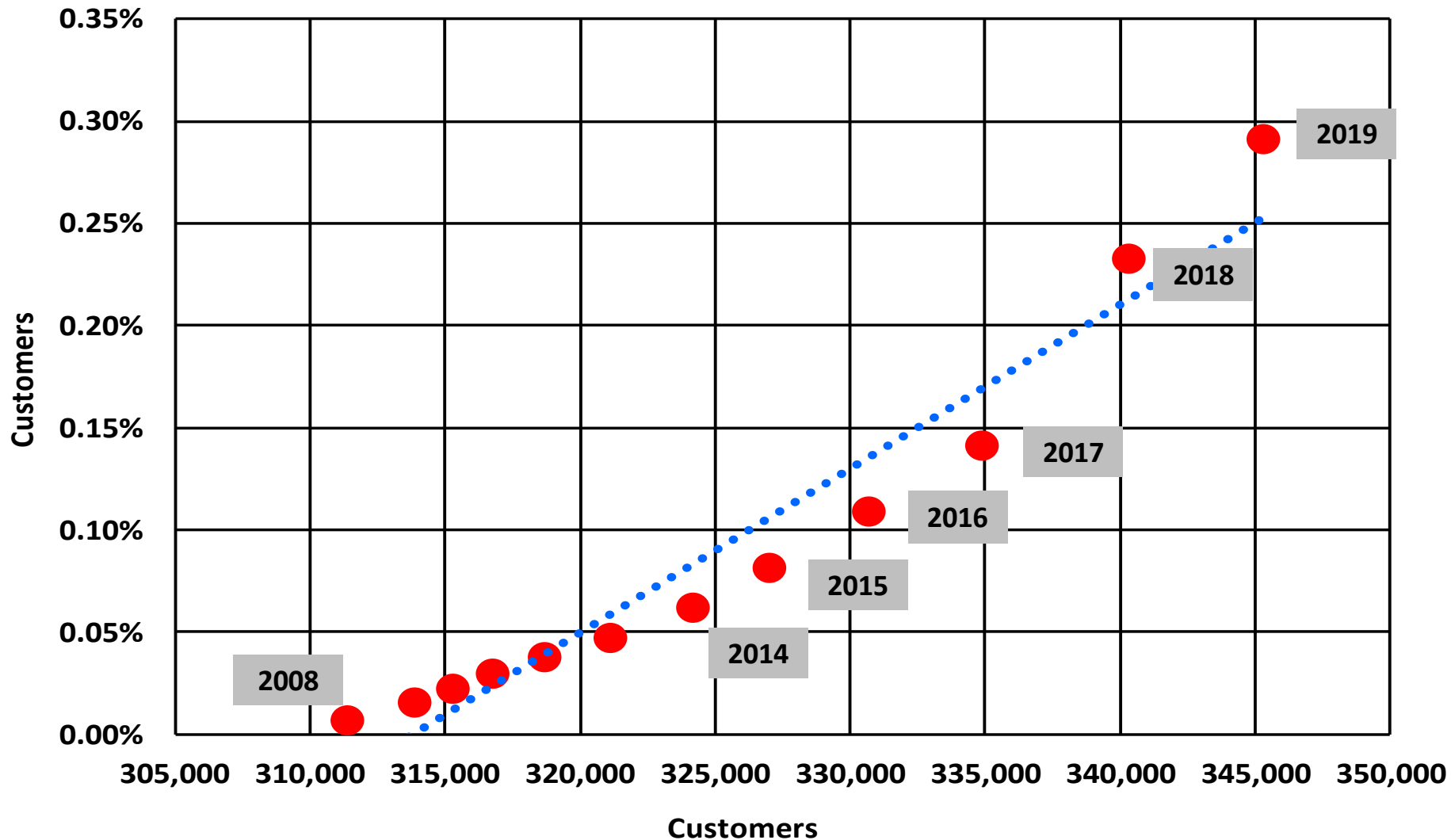

Residential Solar Penetration, 2021-2045

Projected Base-Line Residential Solar Customers

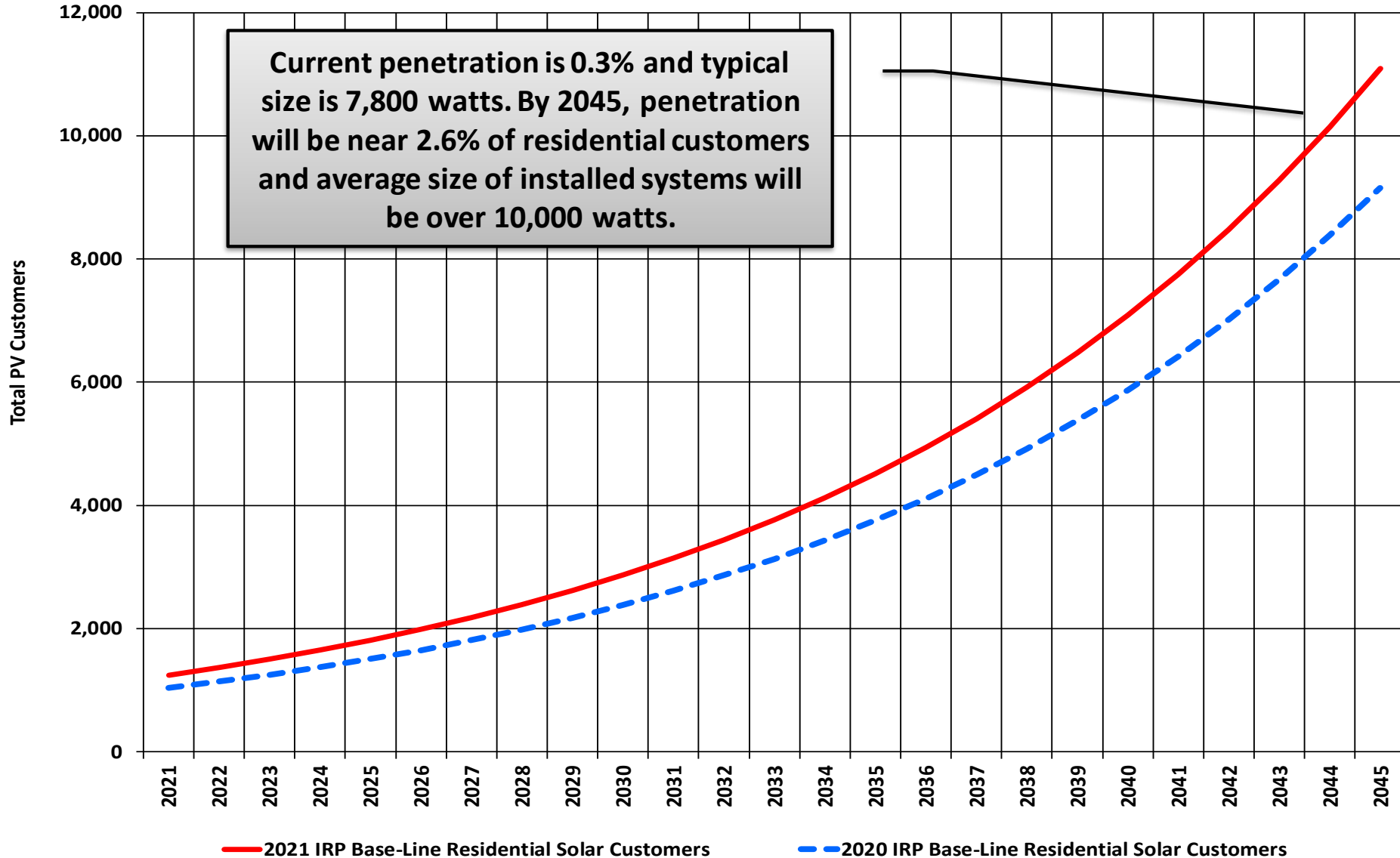

Residential EVs/PHEVs, 2021-2045

Projected Residential EVs/PHEVs

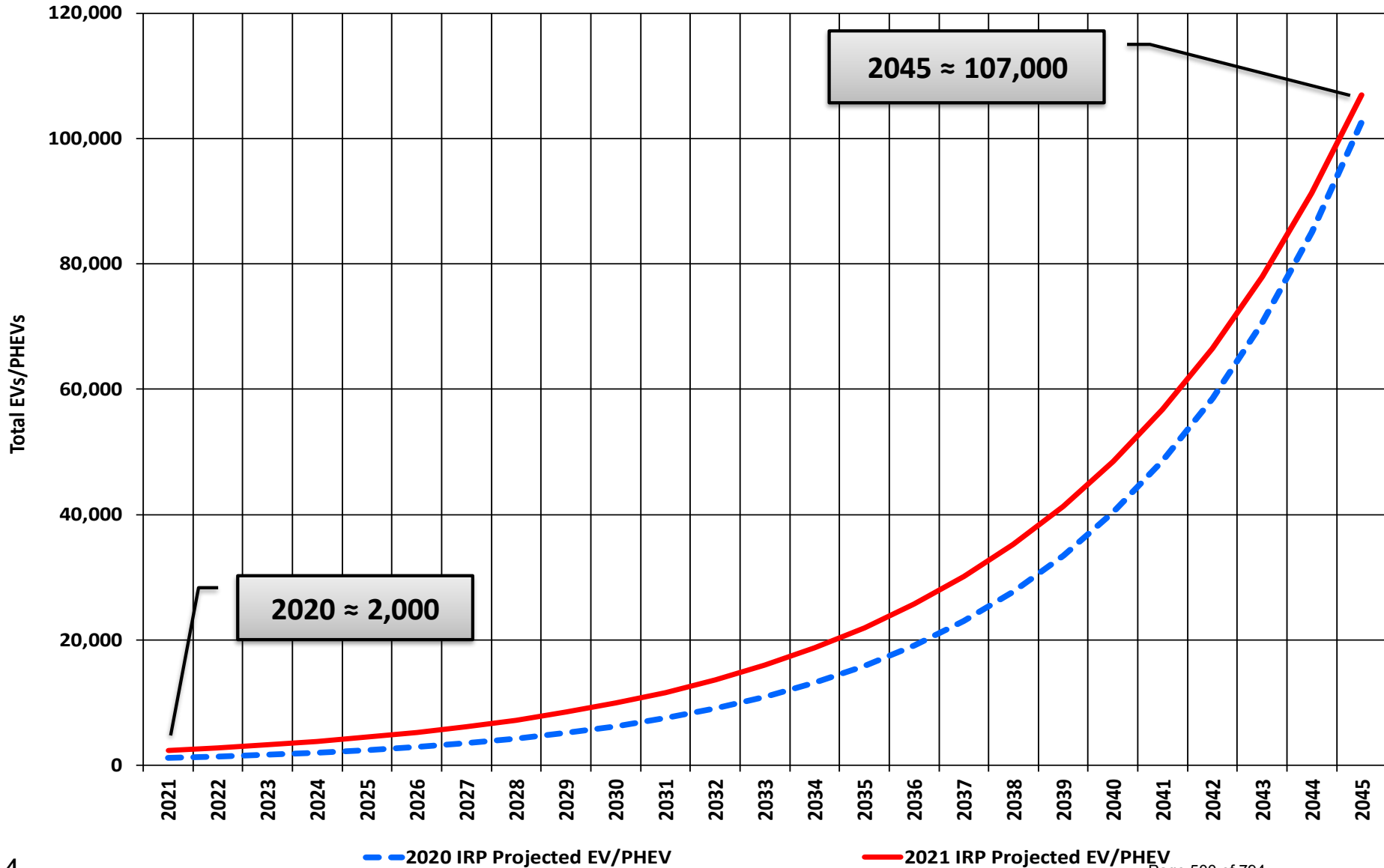

Net Solar and EV/PHEV Impact, 2021-2045

Average Megawatt Impact of Solar and EV/PHEV

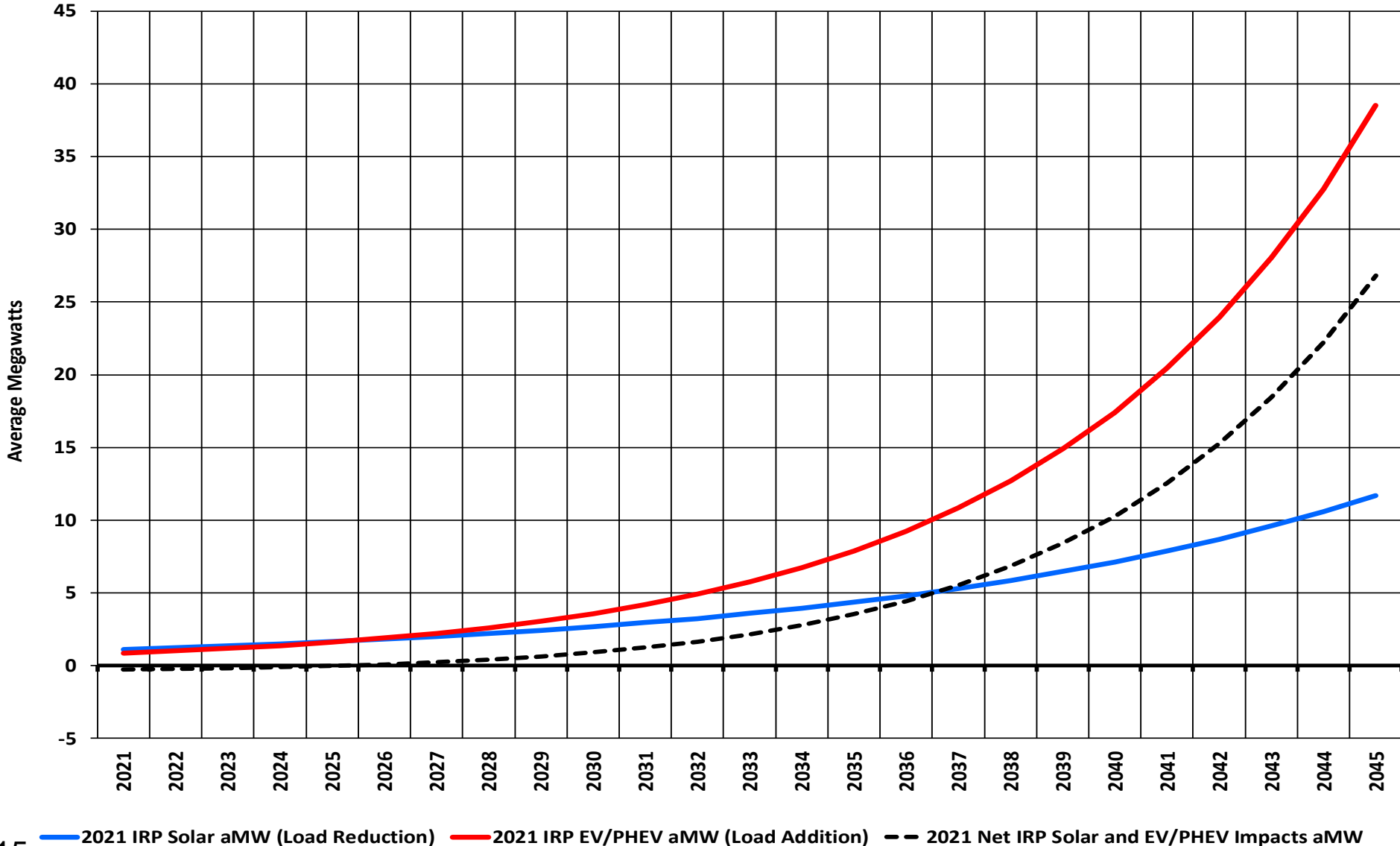

Native Load Forecast, 2021-2045

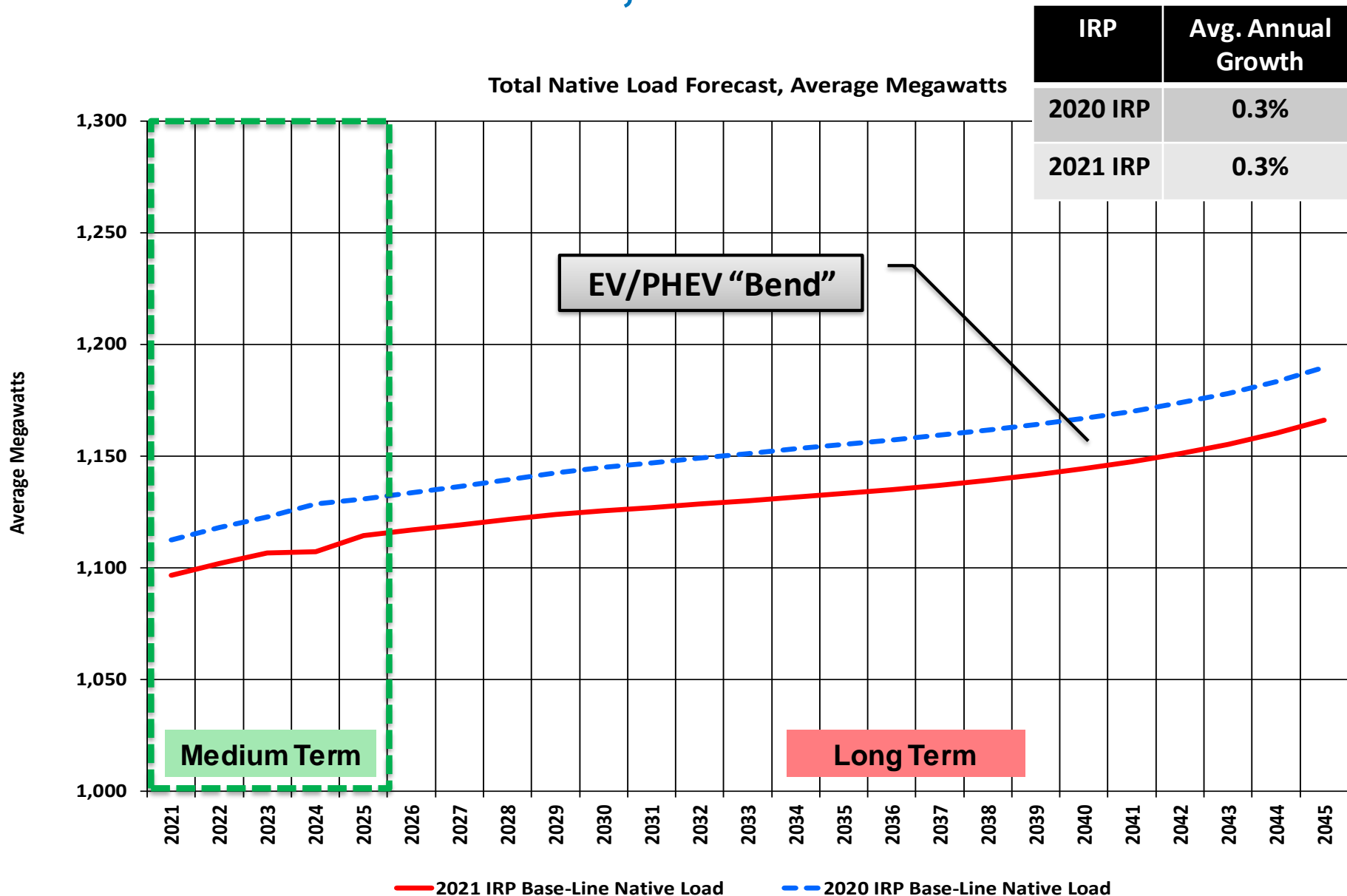

Climate Change: A Trended 20-year Moving Average (Preliminary!)

20-yr MA CDD

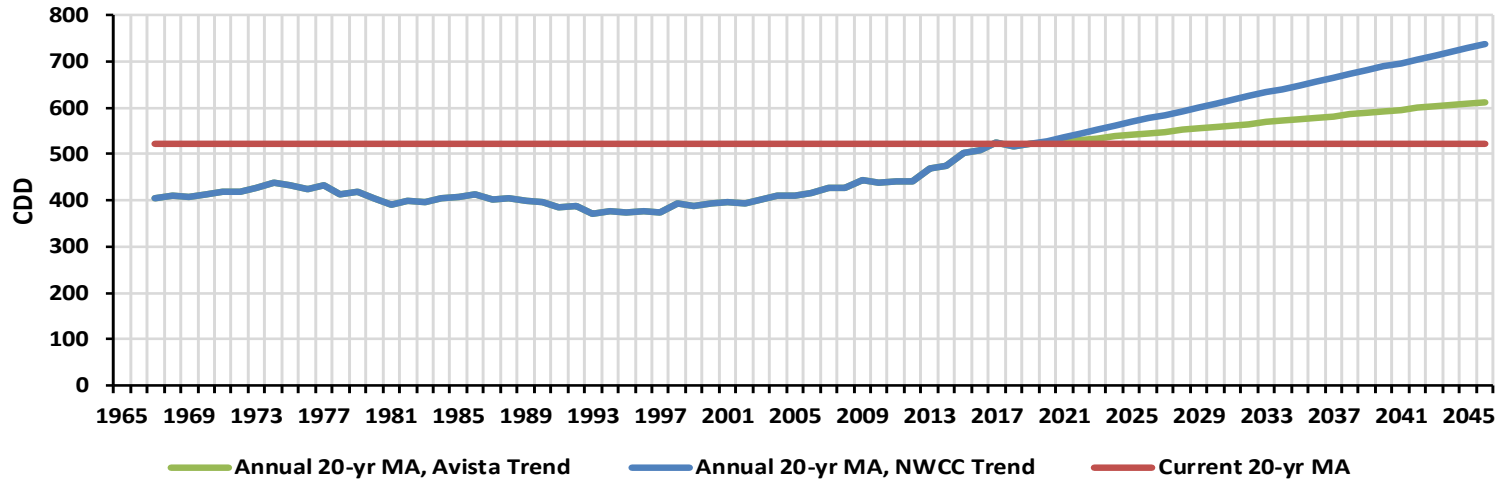

20-yr MA HDD

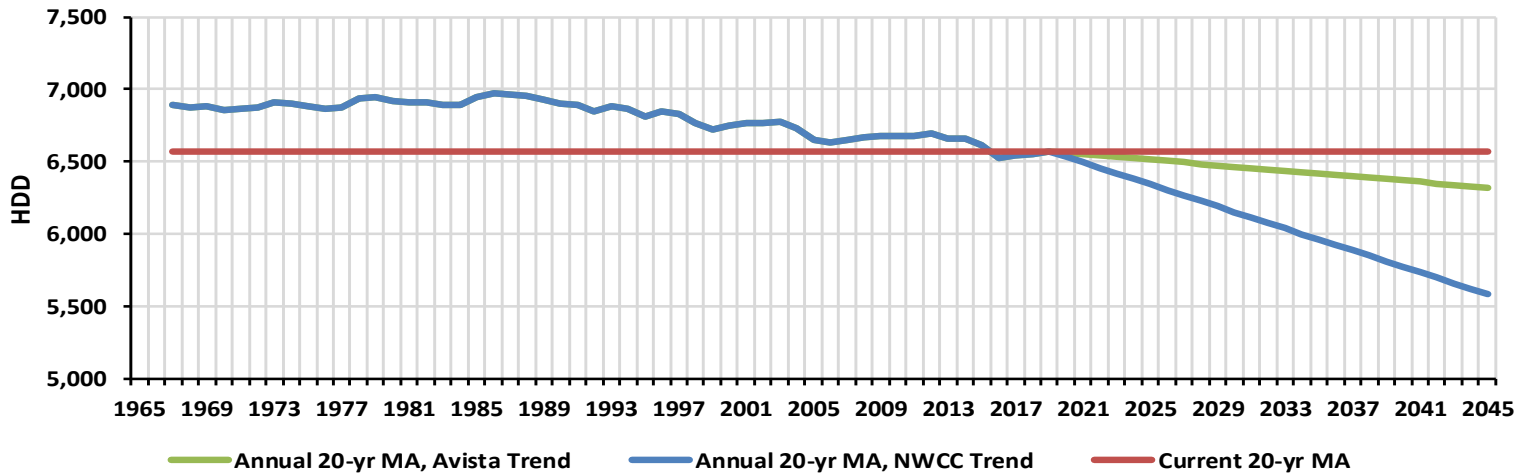

Annual Native Load Forecast with Climate Change, 2026-2045 (Preliminary!)

IRP	Avg. Annual Growth
2021 IRP, No Trend Base-Line	0.23%
2021 IRP, NWCC Trend	0.13%
2021 IRP, Avista Trend	0.21%

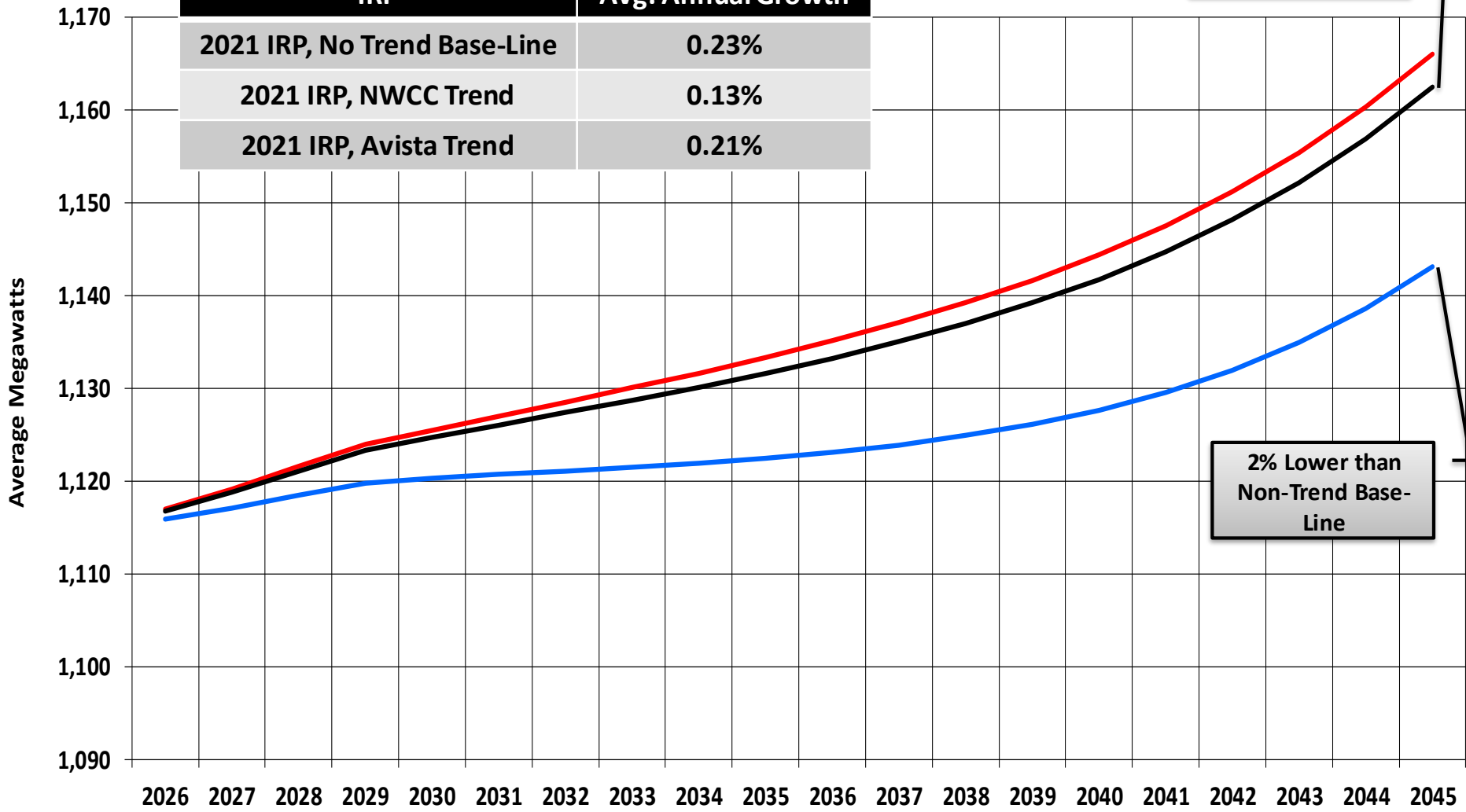

Native Load Growth Forecast, 2021-2045

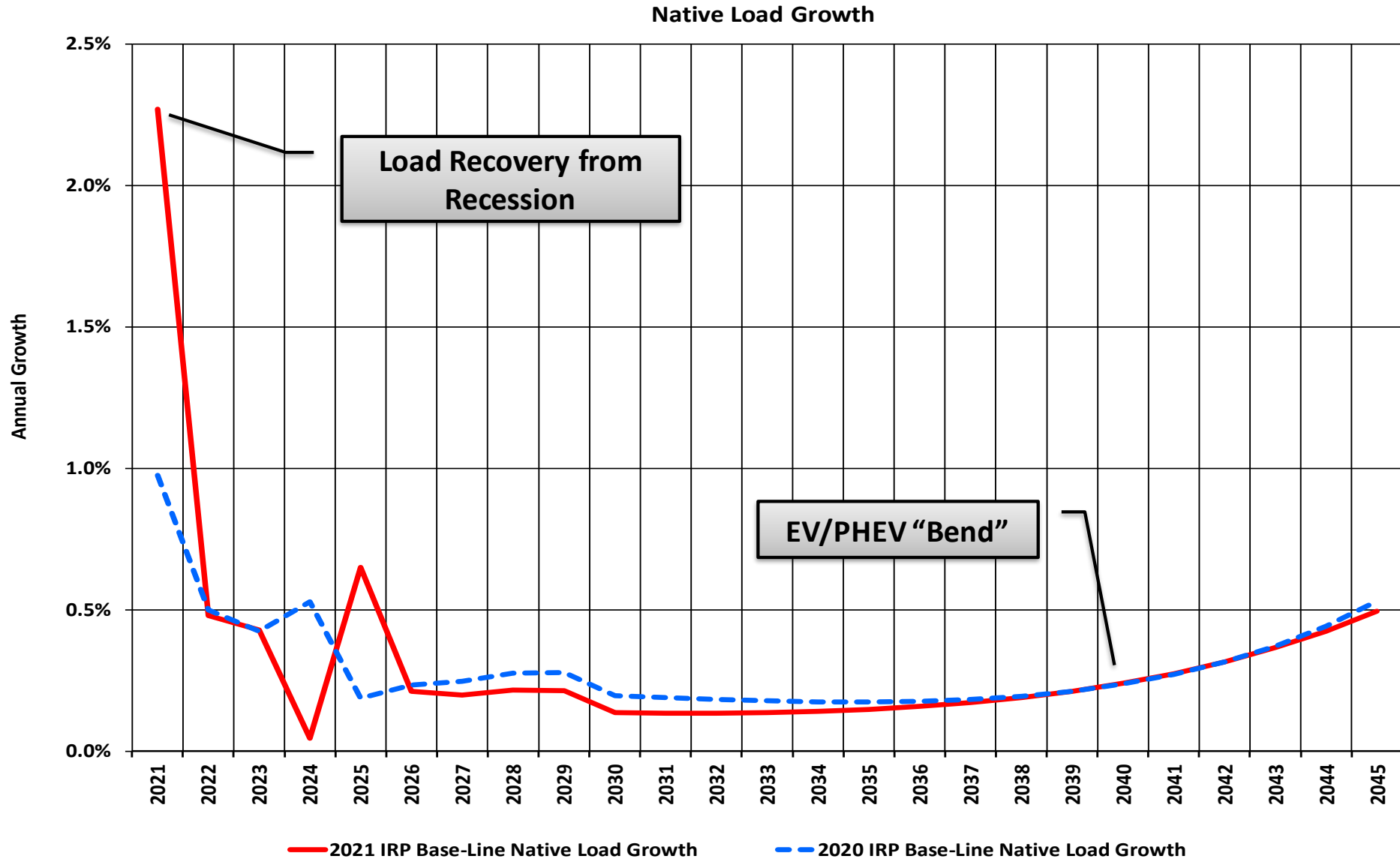

Residential UPC Growth: 2021-2045

Base-Line Scenario: Residential UPC Growth Rate

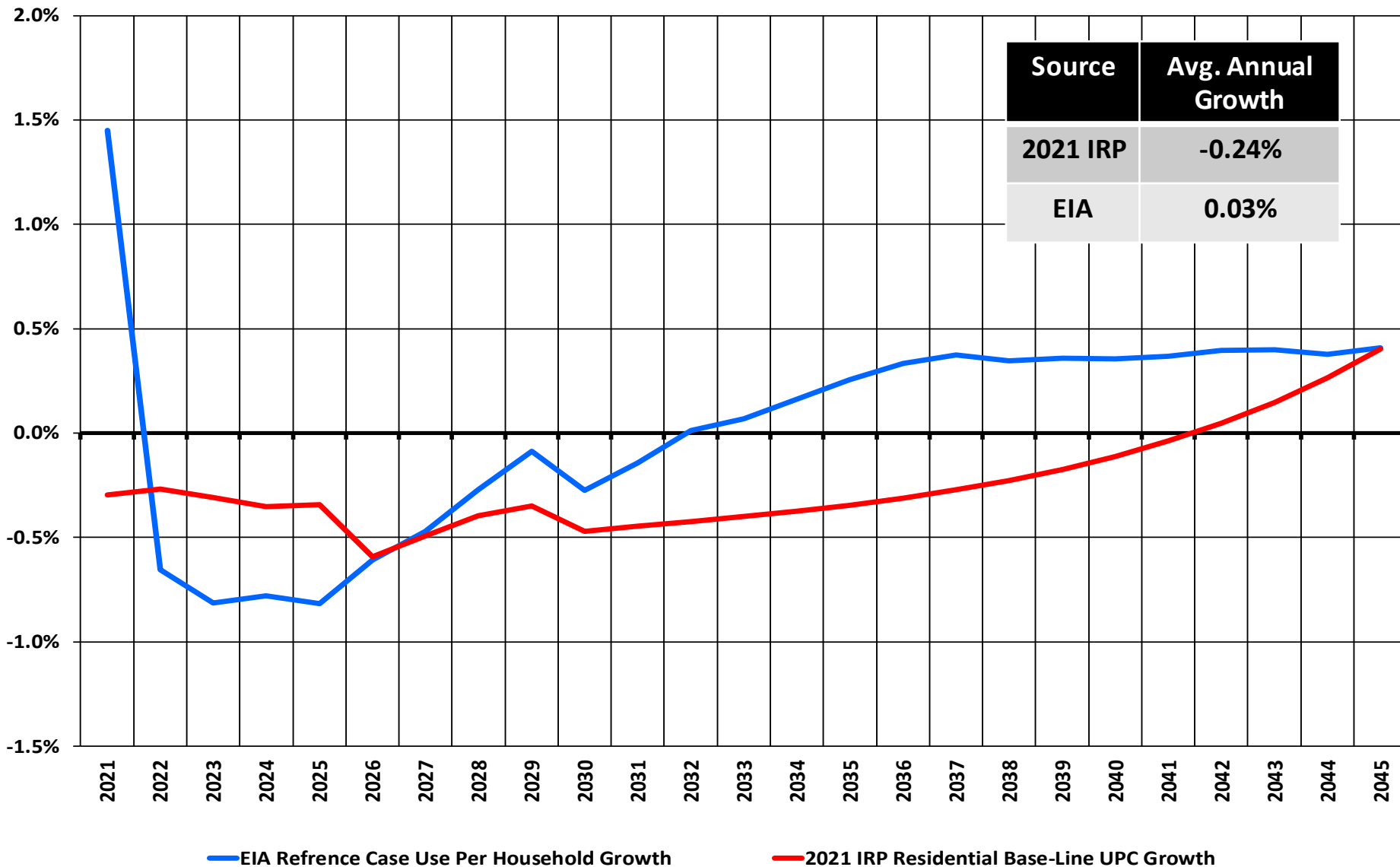



Long-Run Load Forecast: Conservation Adjustment

Grant D. Forsyth, Ph.D.
Chief Economist
Grant.Forsyth@avistacorp.com

Comparison of Native Load Forecasts, 2021-2045

Average Megawatts Load Comparison with Conservation Adjustment

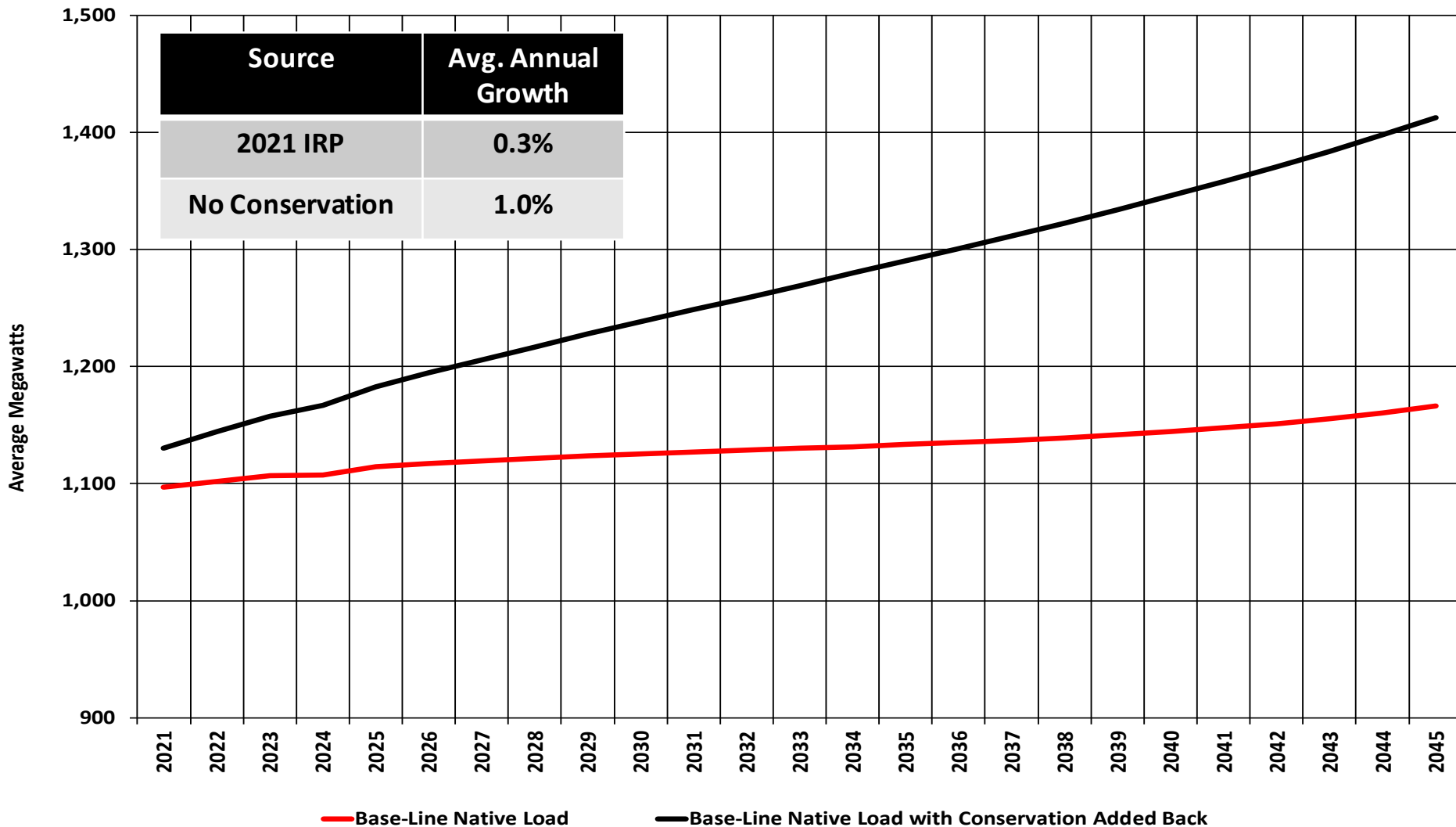



Peak Load Forecast

Grant D. Forsyth, Ph.D.
Chief Economist
Grant.Forsyth@avistacorp.com

The Basic Model

- **Monthly time-series regression model that initially excludes certain industrial loads and EVs (but those are added back in for the final forecast).**
- **Based on monthly peak MW loads since 2004. The peak is pulled from hourly load data for each day for each month.**
- **Explanatory variables include HDD-CDD and monthly and day-of-week dummy variables. The level of real U.S. GDP is the primary economic driver in the model—the higher GDP, the higher peak loads. *Model allows GDP impact to differ between winter and summer.***
- **The coefficients of the model are used to generate a distribution of peak loads by month based on historical max/min temperatures since 1890, holding GDP constant. A starting expected peak load is then calculated using the average peak load simulated for that month going back to 1890. Model shows Avista is a winter peaking utility for the forecast period; however, the summer peak is growing at a faster than the winter peak.**
- **For comparison in the 2021 IRP, peak load is also calculated by averaging simulated peak loads over the last 30 years and 20 years.**
- **The model is also used to calculate the long-run growth rate of peak loads for summer and winter using a forecast of GDP growth under the “*ceteris paribus*” assumption for weather and other factors.**

Peak Forecasts for Winter and Summer, 2021-2045

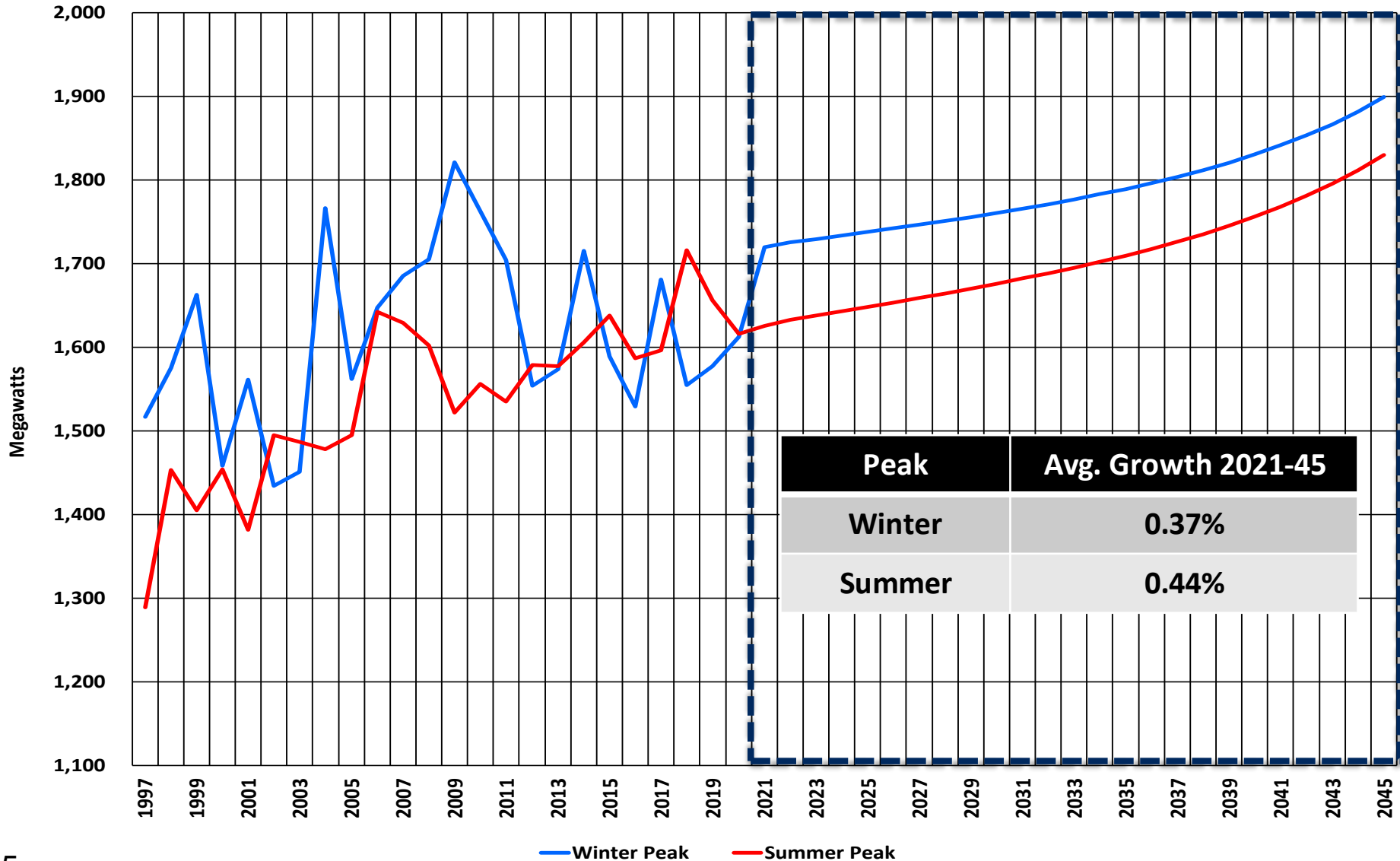

Load Forecasts for Winter Peak, 2011-2043

Winter Peak Forecast: Current and Past

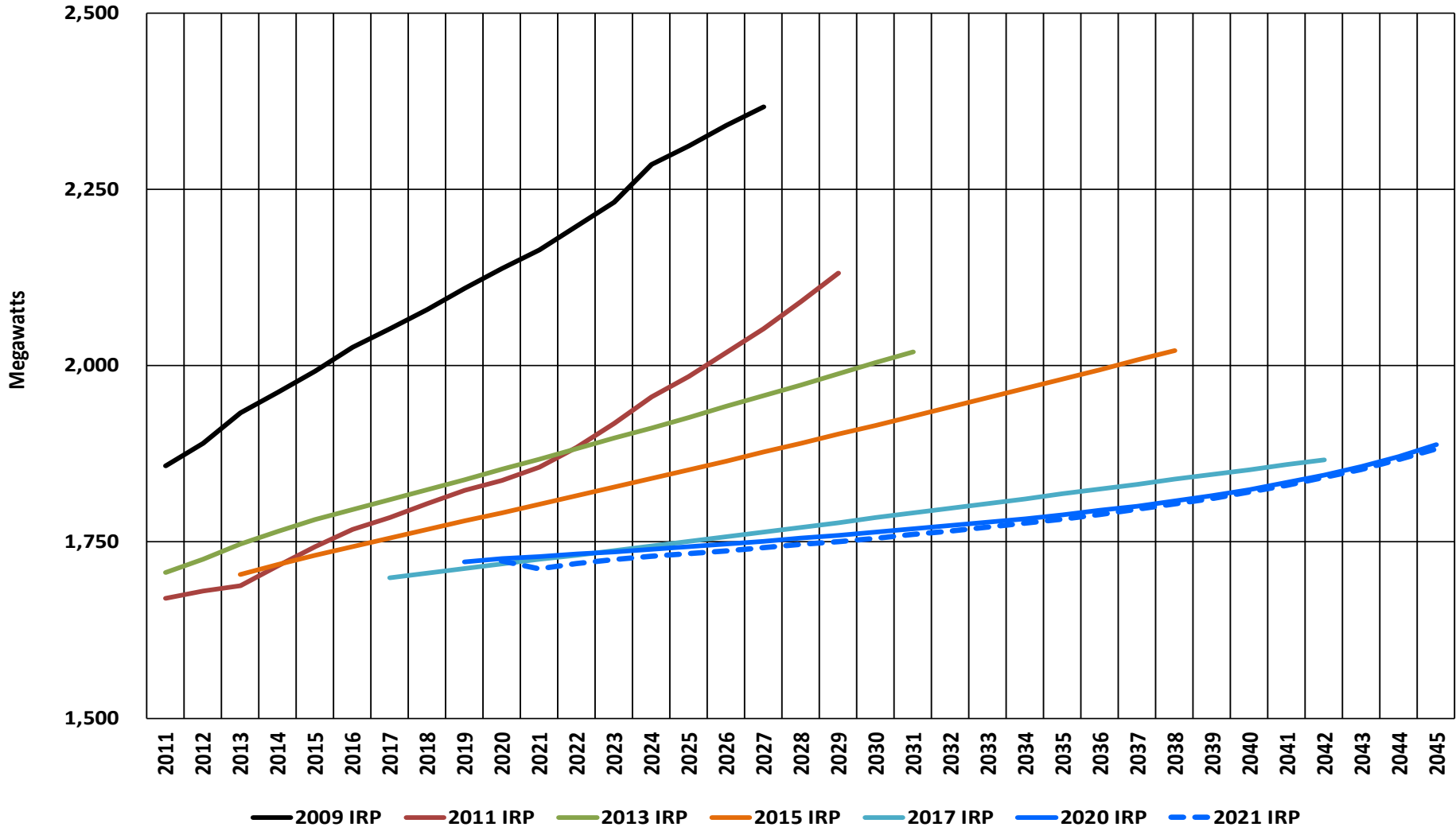

Load Forecasts for Summer Peak, 2011-2045

Summer Peak Forecast: Current and Past

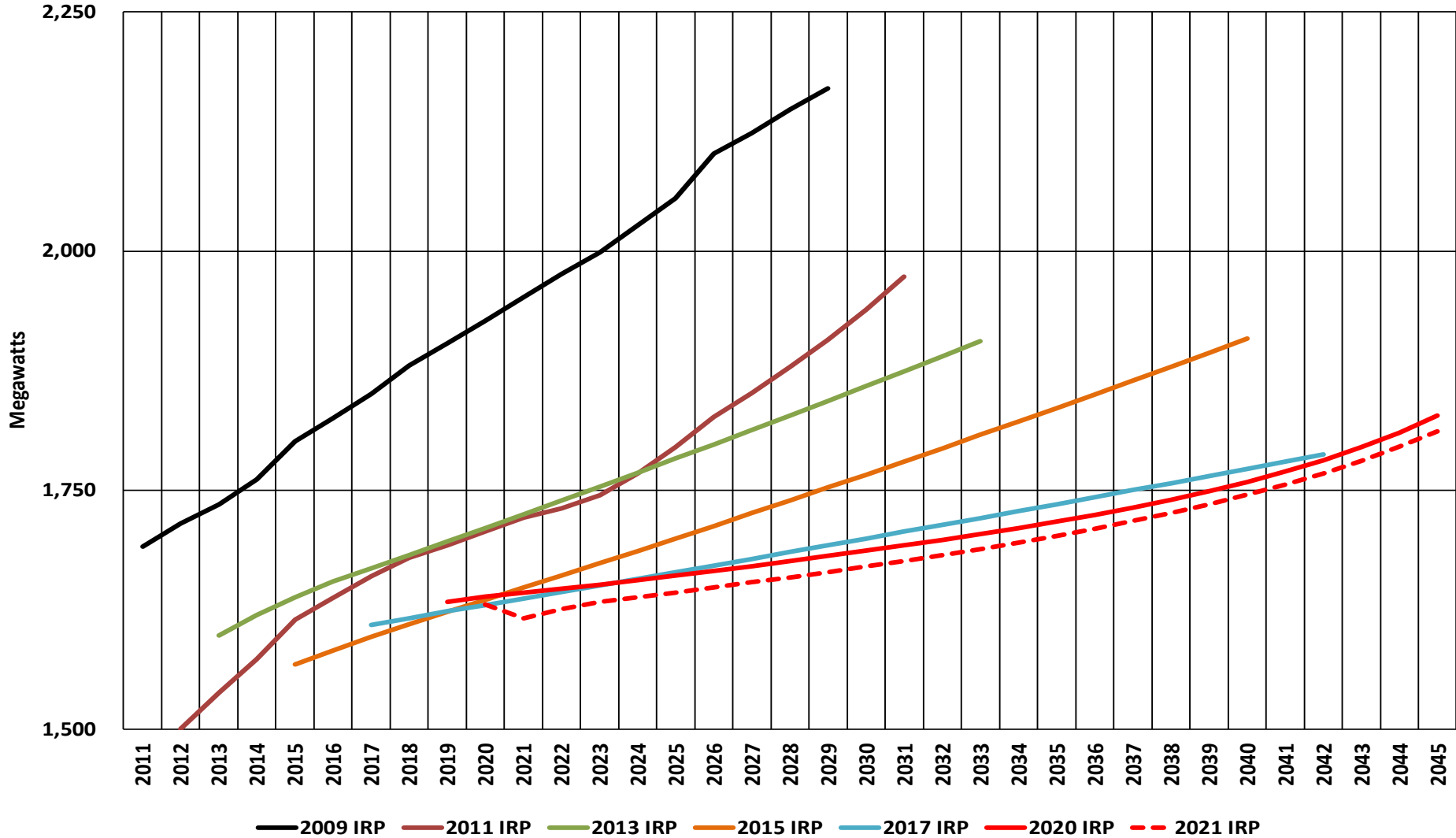

Peak Forecasts for Winter and Summer 30-Year Average Weather, 2021-2045

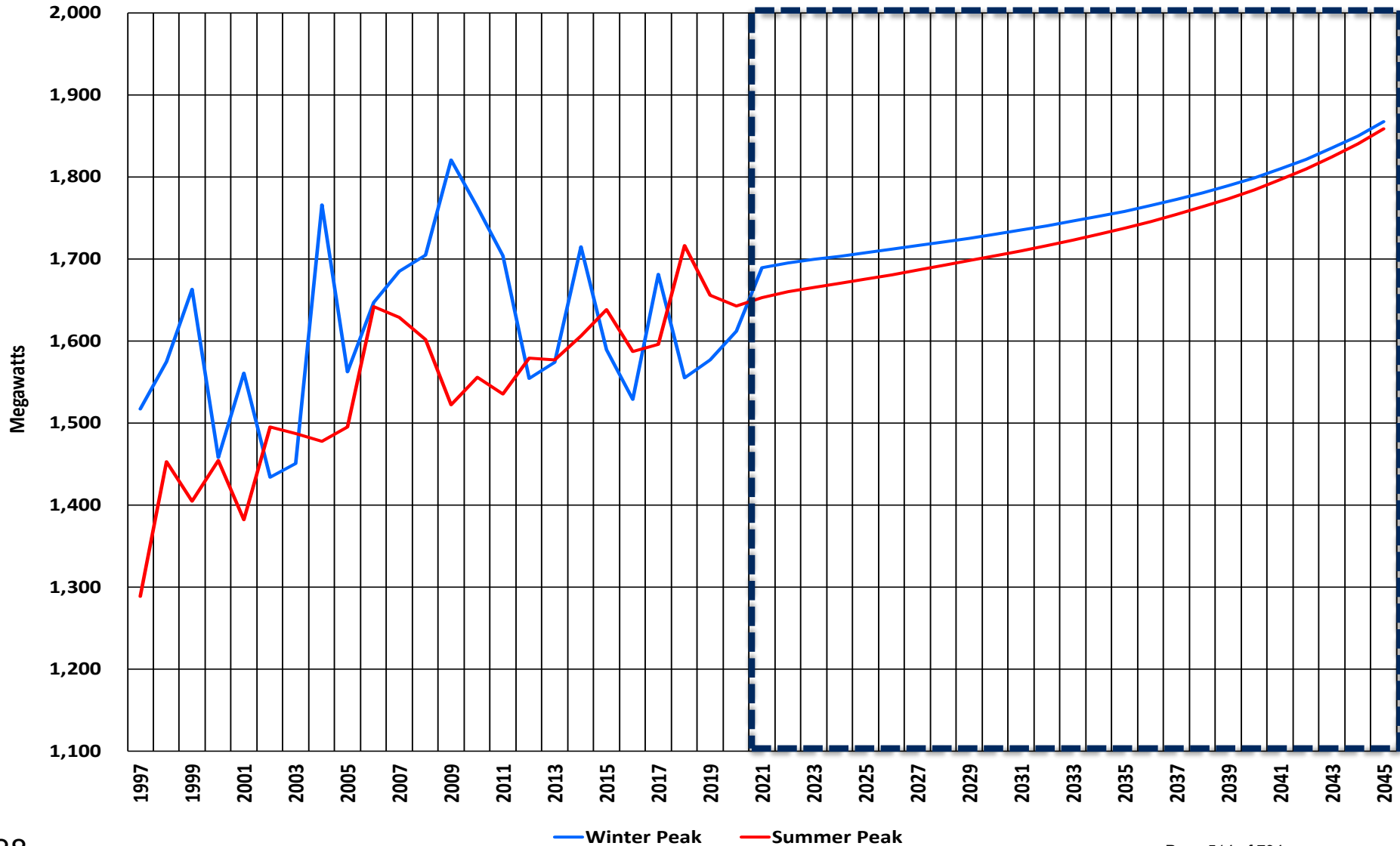

Peak Forecasts for Winter and Summer 20-Year Average Weather, 2021-2045

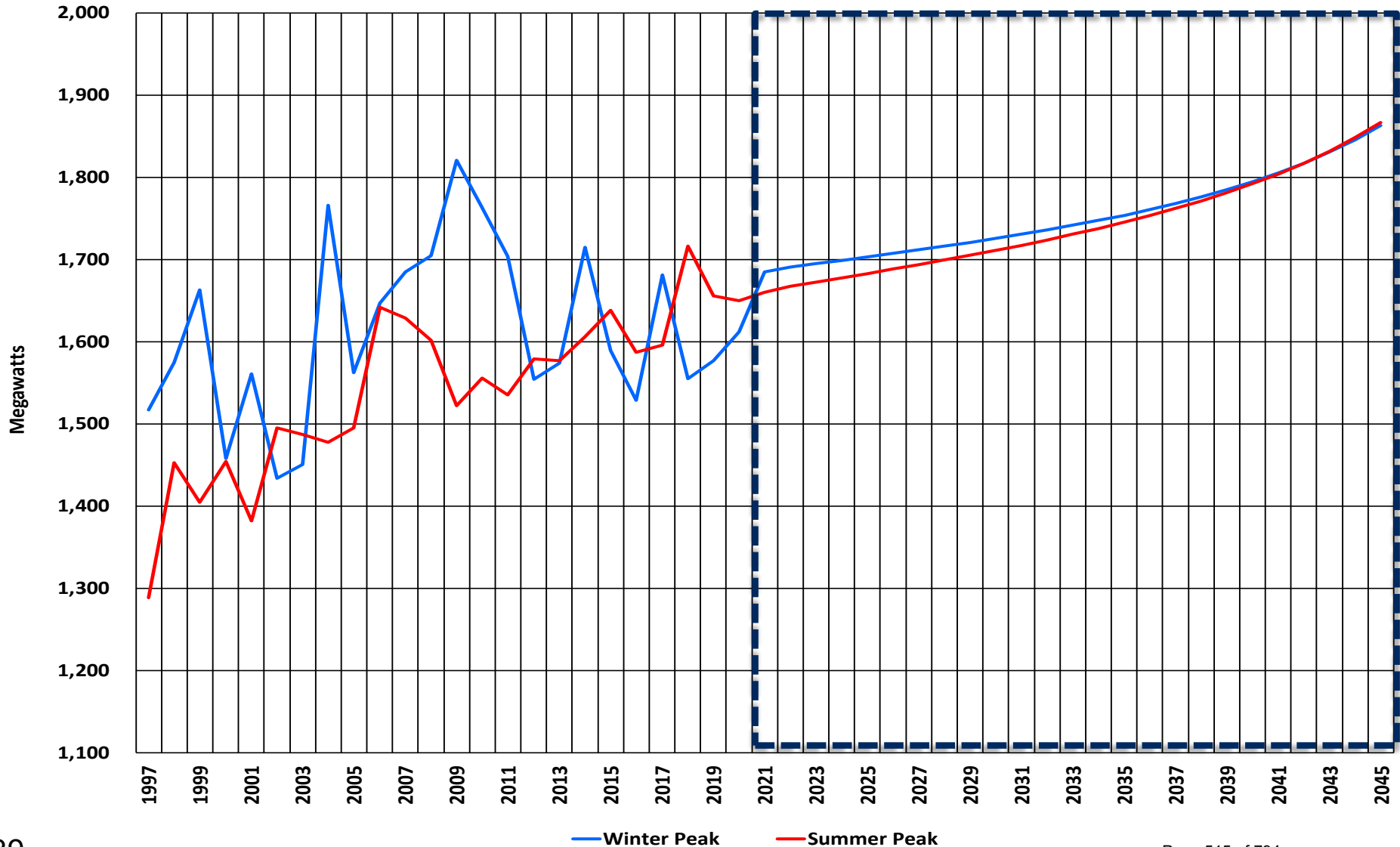



Long-Run Customer Forecast: Natural Gas

Grant D. Forsyth, Ph.D.
Chief Economist
Grant.Forsyth@avistacorp.com

Firm Customers (Meters) by State and Class, 2019

Firm Customers by State

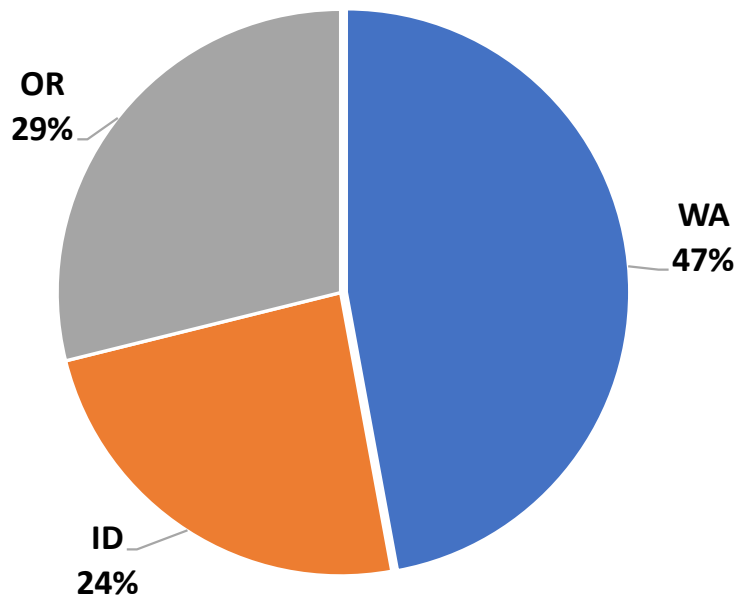

Firm Customers by Class

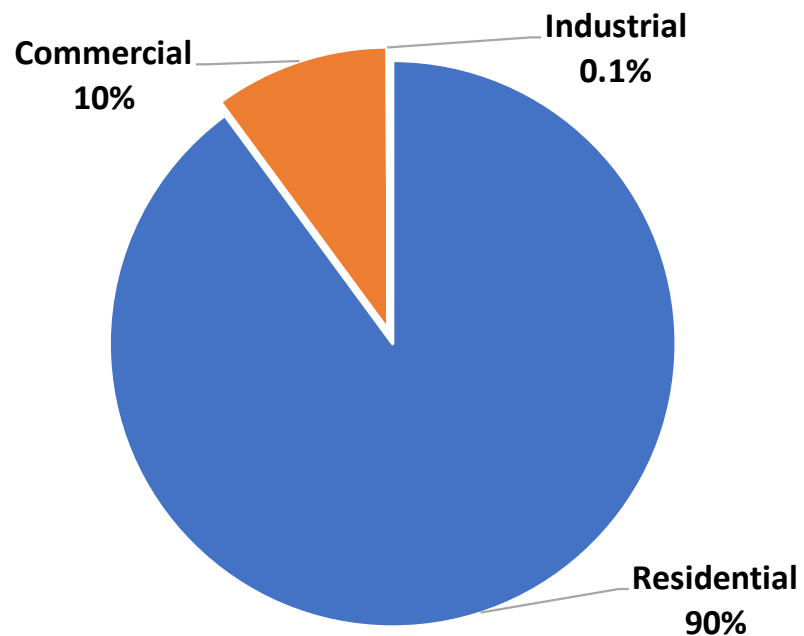

System All Types of Industrial Customers, 1997-2020

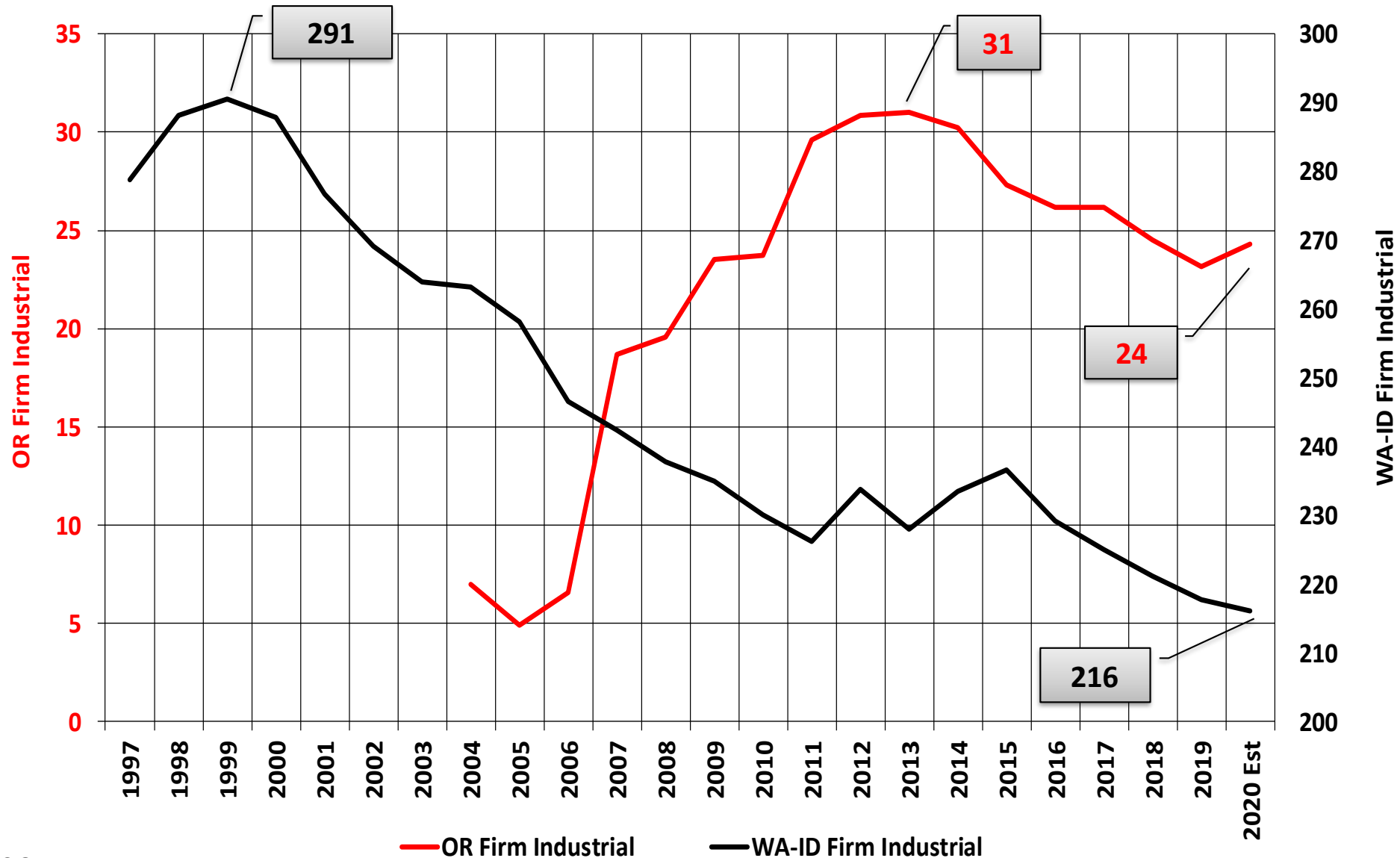

Customer Forecast Models

- Forecast models are structured around each schedule, in each class, by jurisdiction. In the case of OR, this is done individually for each of Avista's service islands.
- Time series transfer function models (models with regressions drivers and ARIMA error terms).
- Simple time series smoothing models (for schedules with little customer variation).
- Same models used for the bi-annual revenue model forecast pushed out to 2045. The forecasts for this IRP were generated from the "Summer/Fall 2020" forecast completed in June.
- Customer forecasts are sent to Gas Supply for inclusion in the SENDOUT model.
- Example of transfer function model: WA sch. 101 residential customers...

Transfer Function Model Example

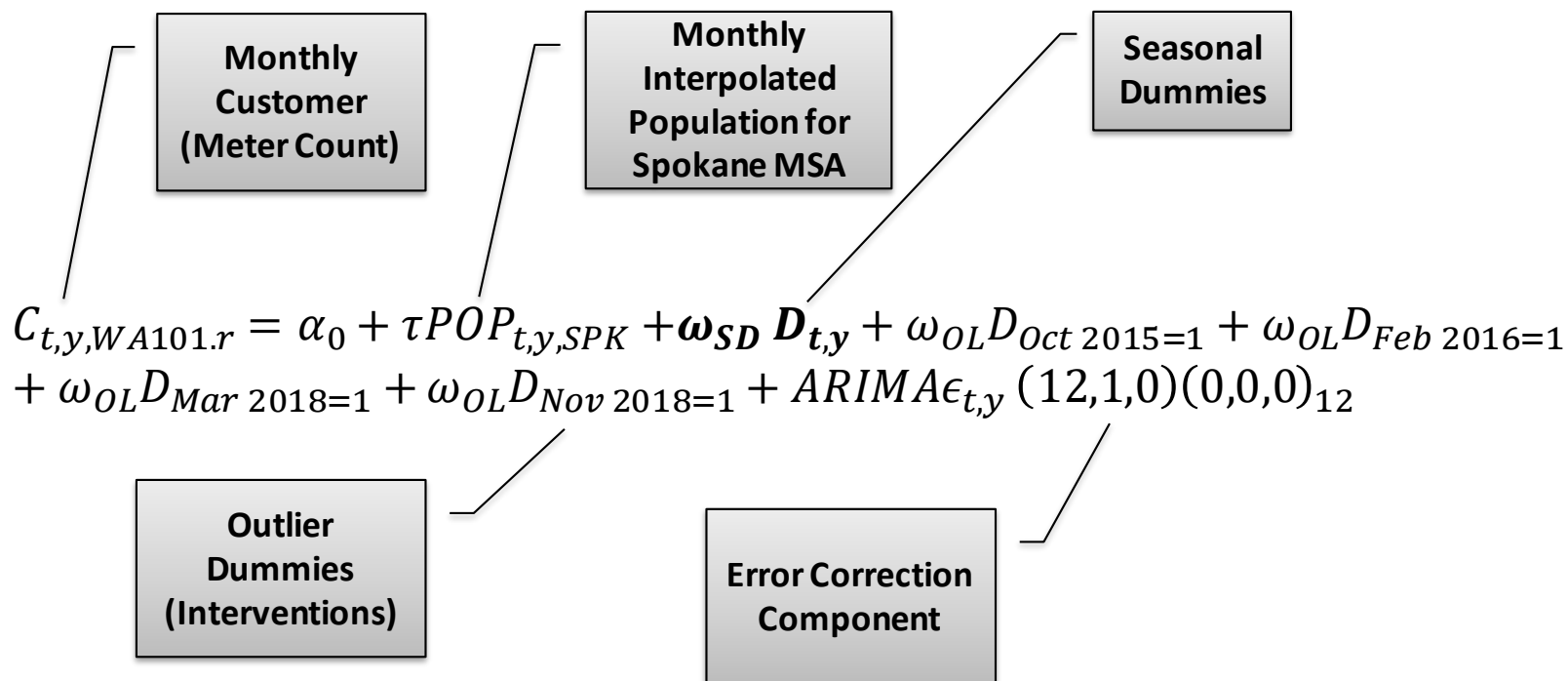

Getting to Population as a Driver, 2020-2025 & 2026-2045

2020-2025 For Spokane, WA; Kootenai, ID, and Jackson+Josephine, OR

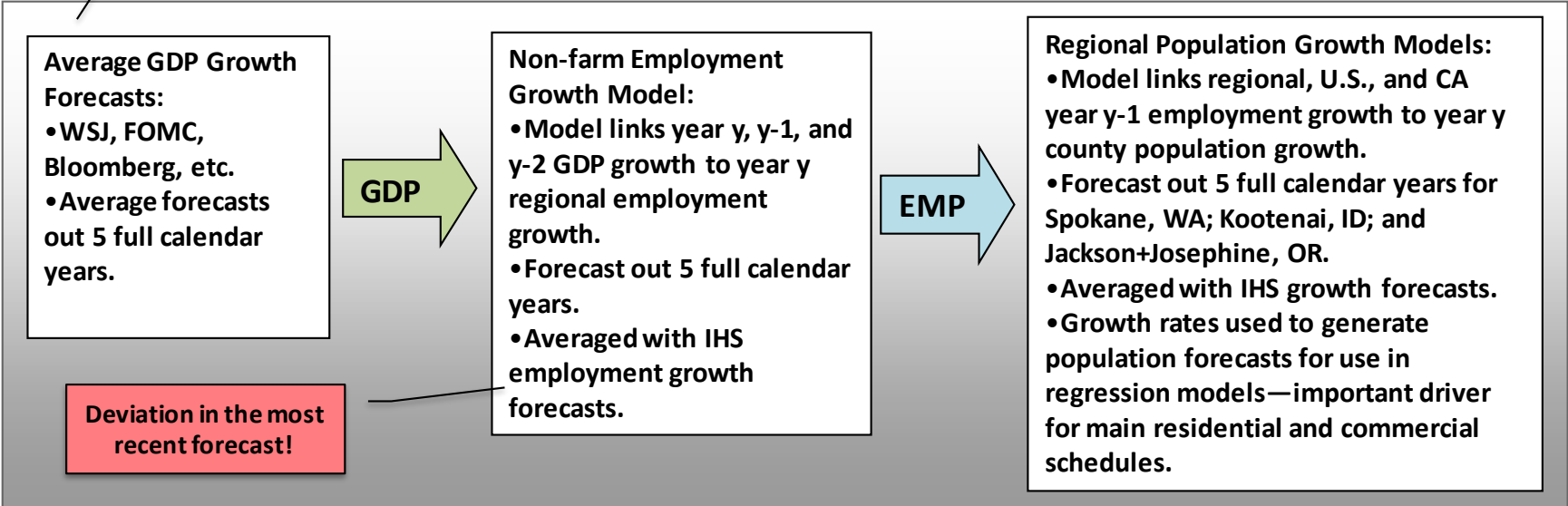

Kootenai and Jackson: IHS population growth forecasts for 2026-2045

Spokane: OFM population growth forecasts for 2026-2045

OR Douglas, Klamath, and Union counties: IHS population growth forecasts for 2020-2045

Monthly Interpolation assumes: $P_N = P_0 e^{rN}$



WA-ID Region Firm Customers, 2021-2040 (2018 IRP)

IRP	Avg. Annual Growth 2021-2040
2021	1.1%
2018	1.2%

≈ +1,400

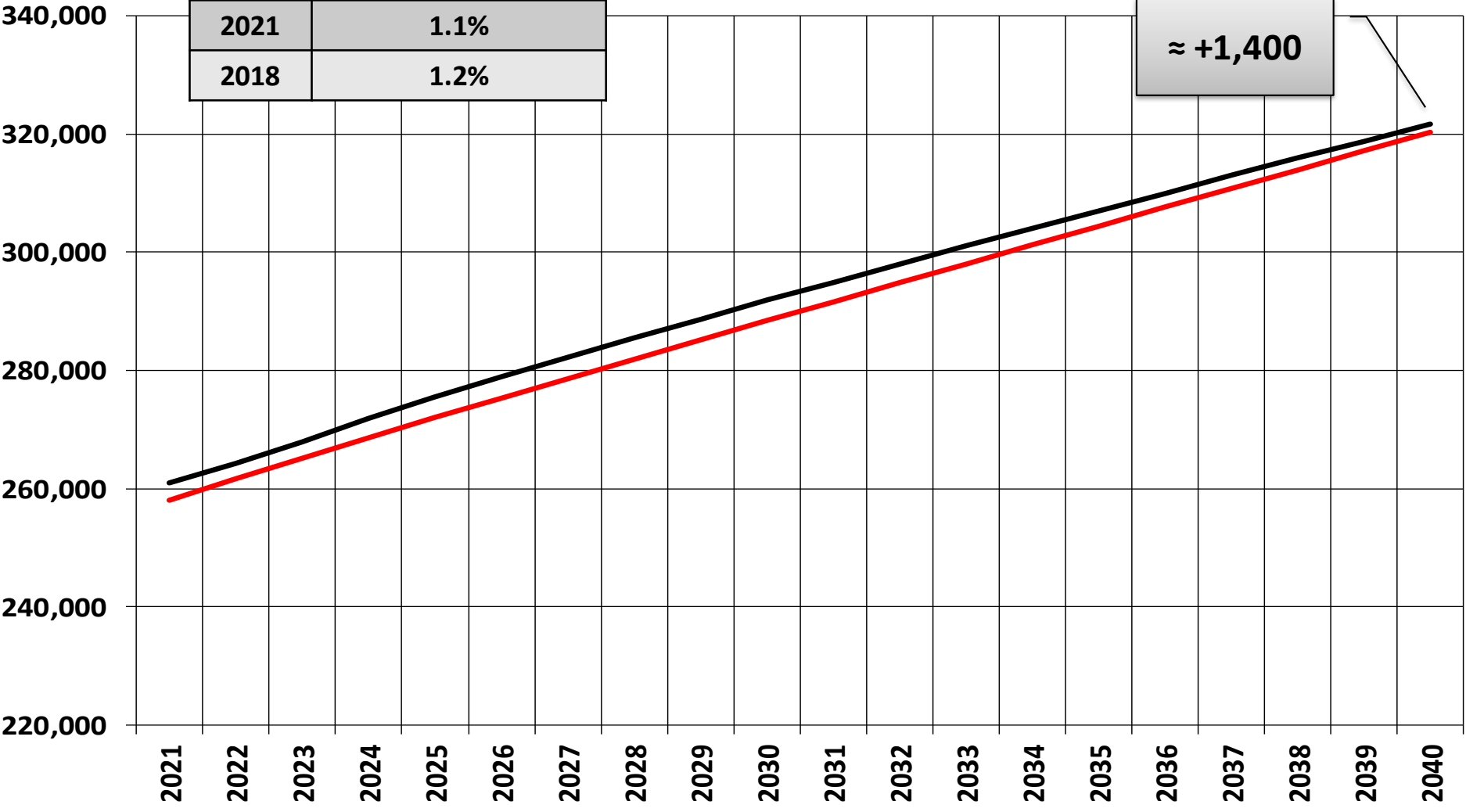

— WA-ID Base-line 2018 — WA-ID Base-line 2021

OR Region Firm Customers, 2021-2040 (2018 IRP)

IRP	Avg. Annual Growth 2021-2040
2021	0.8%
2018	0.9%

≈ -2,800

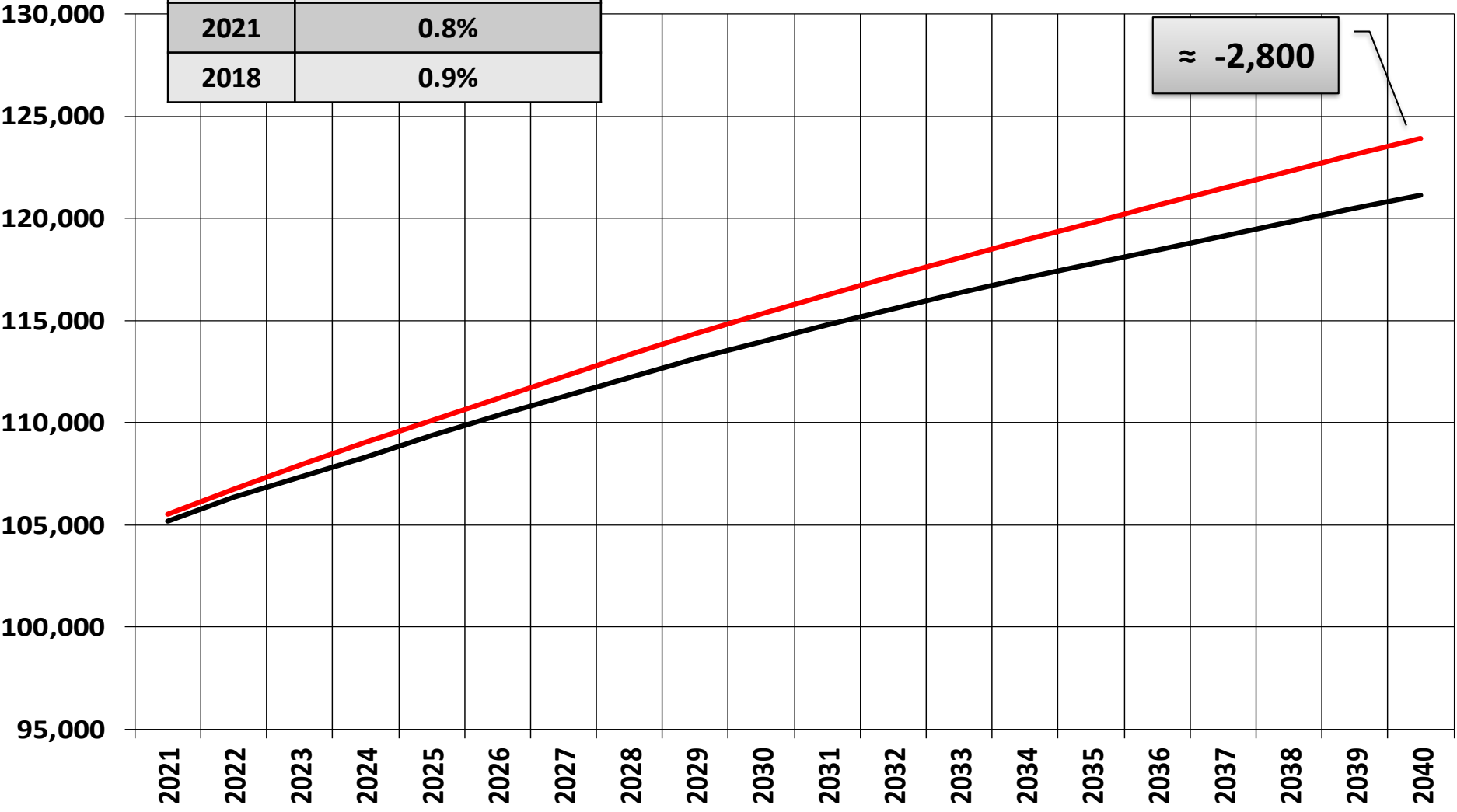

— OR Base-line 2018 — OR Base-line 2021

Medford, OR Region Firm Customers, 2021-2040 (2018 IRP)

IRP	Avg. Annual Growth 2021-2037
2021	0.9%
2018	0.9%

≈ +310

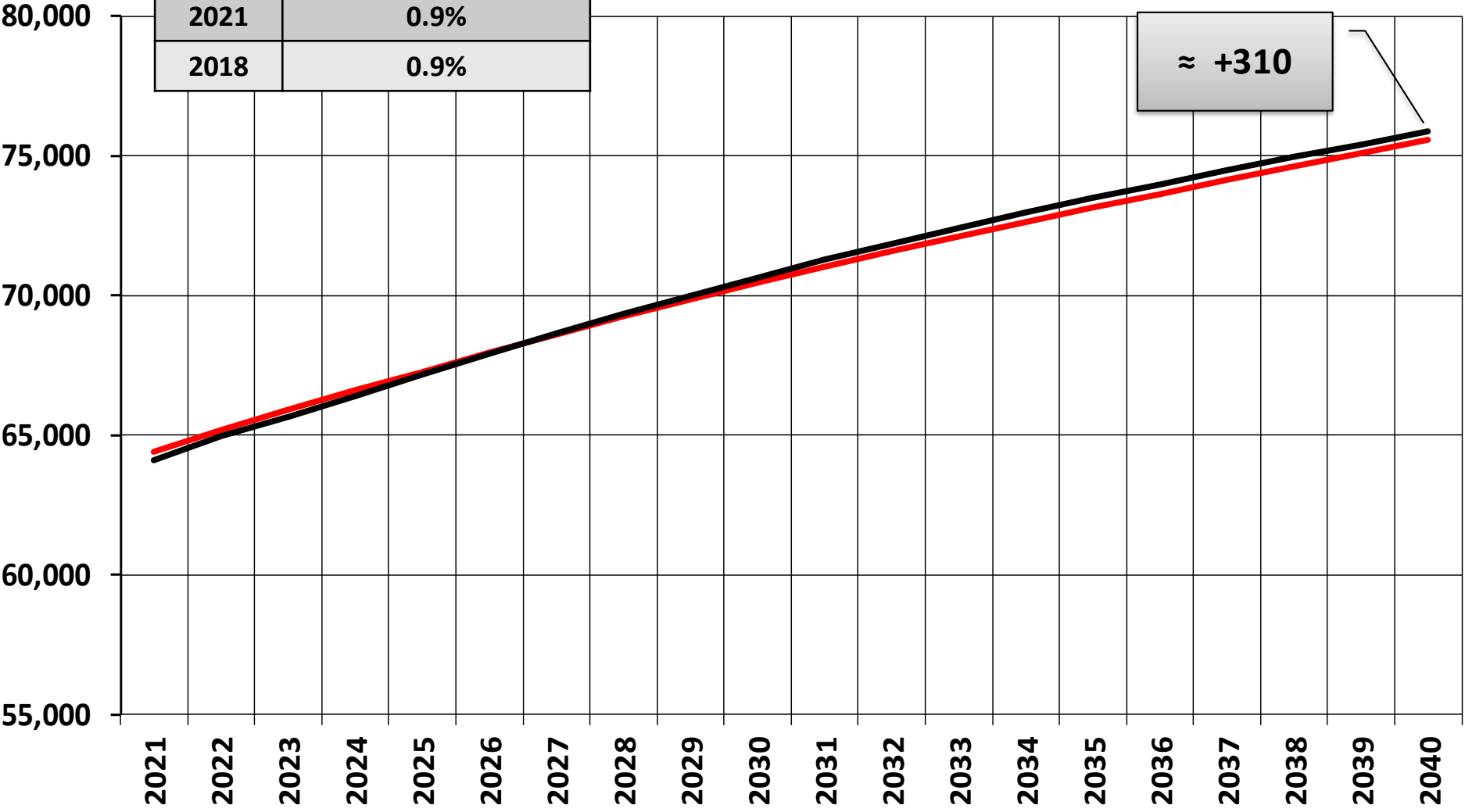

— Medford Base-line 2018 — Medford Base-line 2021

Roseburg, OR Region Firm Customers, 2021-2040 (2018 IRP)

IRP	Avg. Annual Growth 2021-2040
2021	0.4%
2018	0.9%

≈ -1,900

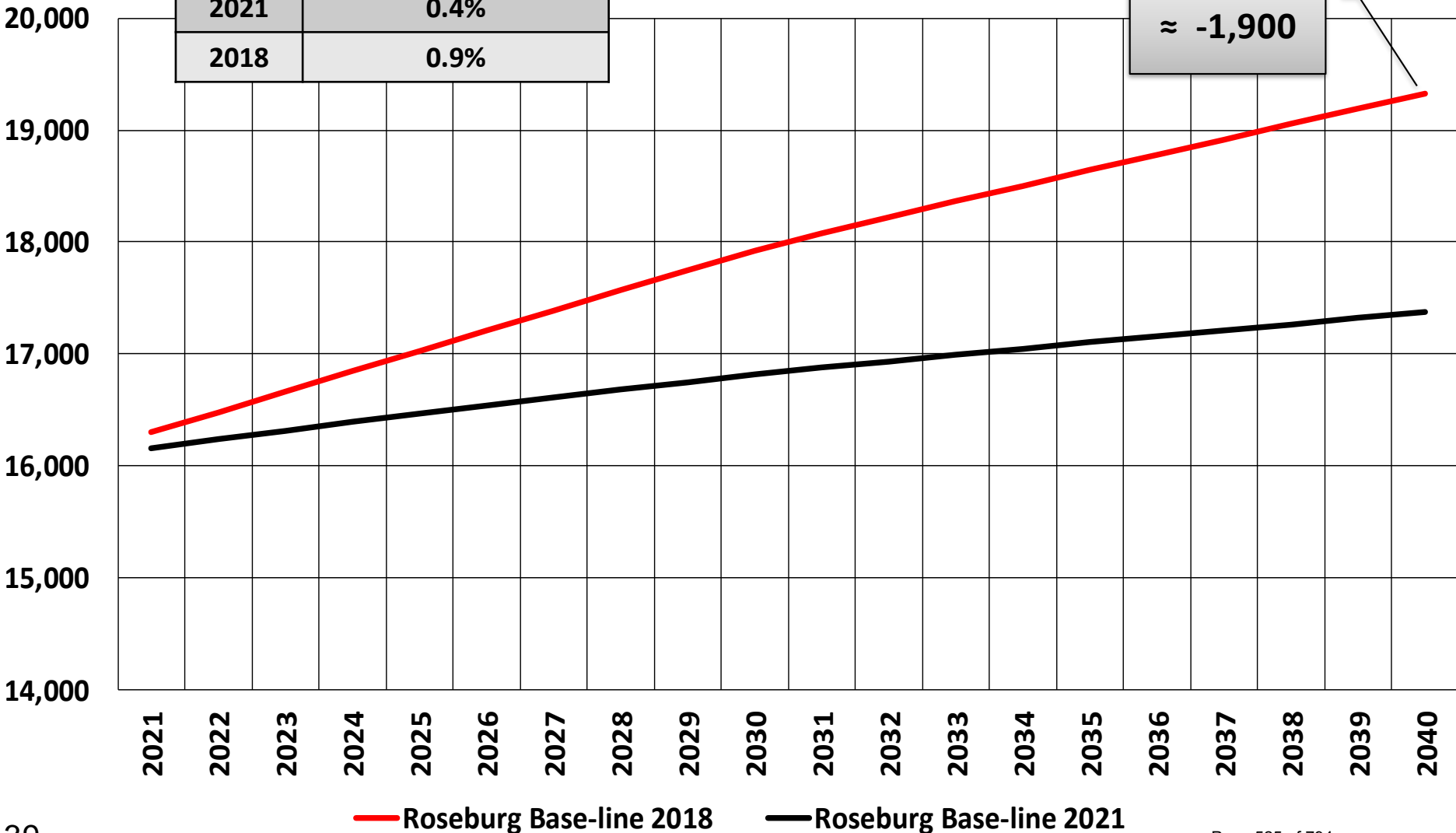

Klamath, OR Region Firm Customers, 2021-2040 (2018 IRP)

IRP	Avg. Annual Growth 2021-2040
2021	0.7%
2018	1.0%

≈ -1,200

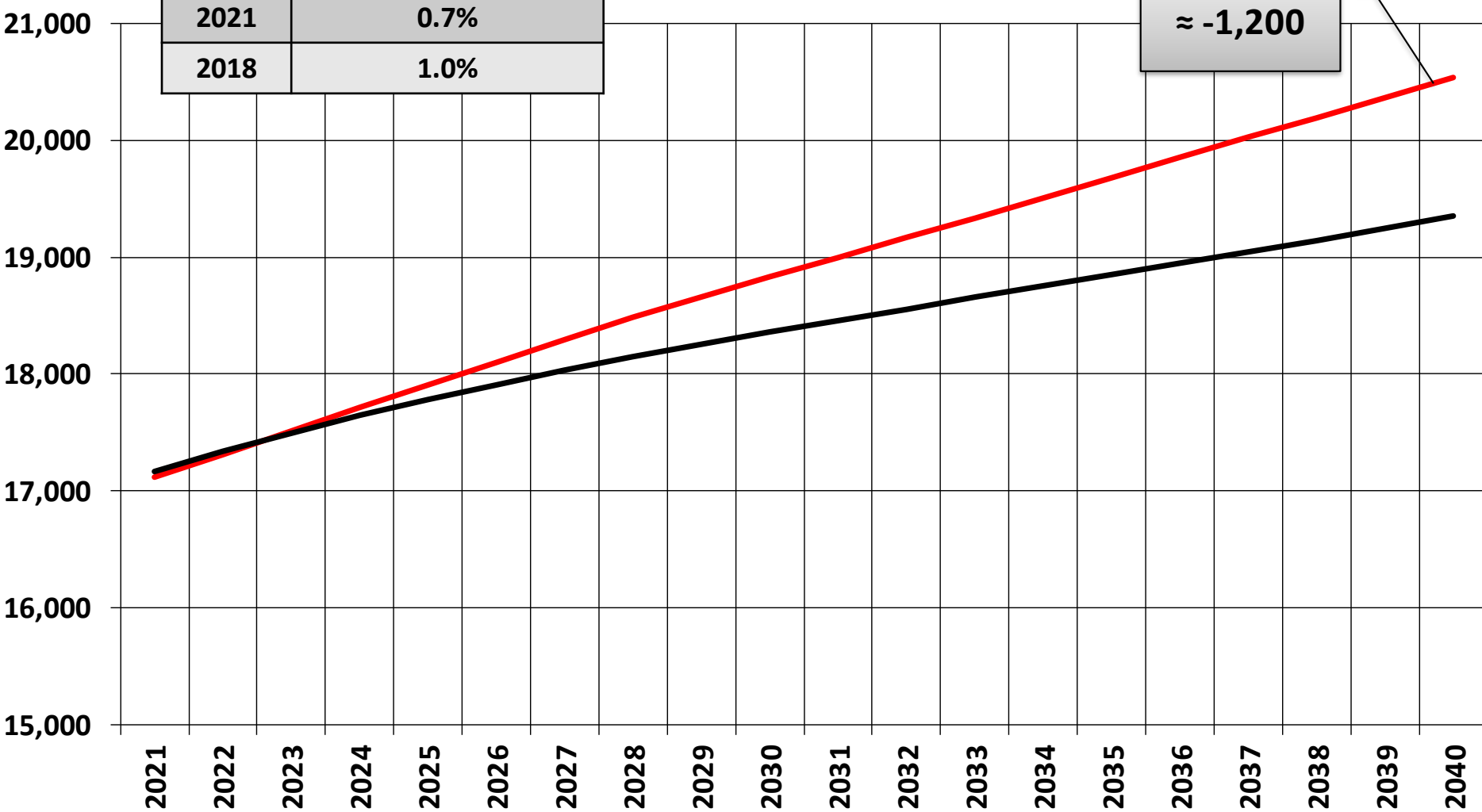

— Klamath Base-line 2018 **—** Klamath Base-line 2021

La Grande, OR Region Firm Customers, 2021-2040 (2018 IRP)

IRP	Avg. Annual Growth 2021-2040
2021	0.5%
2018	0.5%

≈ +30

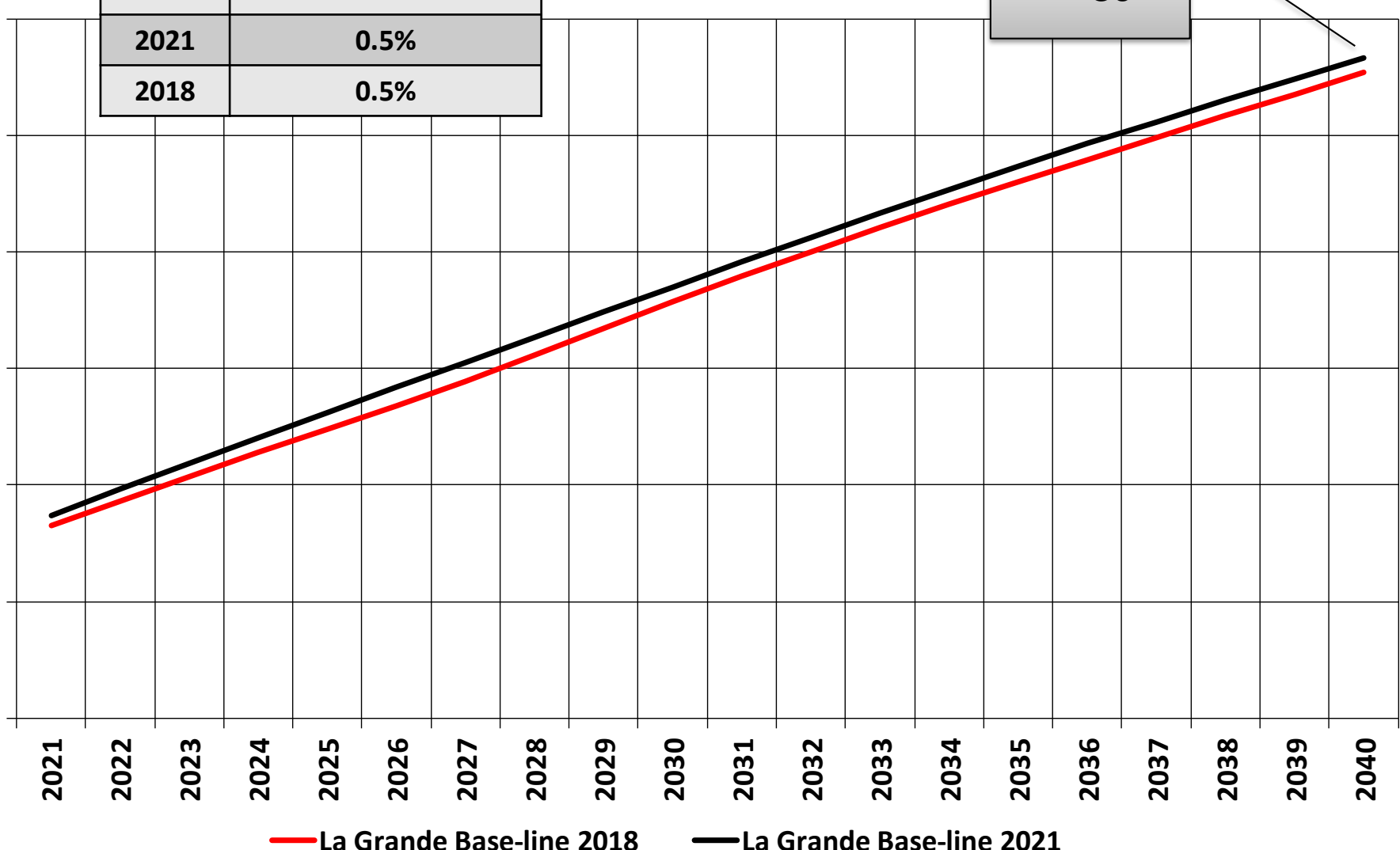

System Firm Customers, 2021-2040 (2018 IRP)

IRP	Avg. Annual Growth 2021-2040
2021	1.0%
2018	1.1%

≈ -1,400

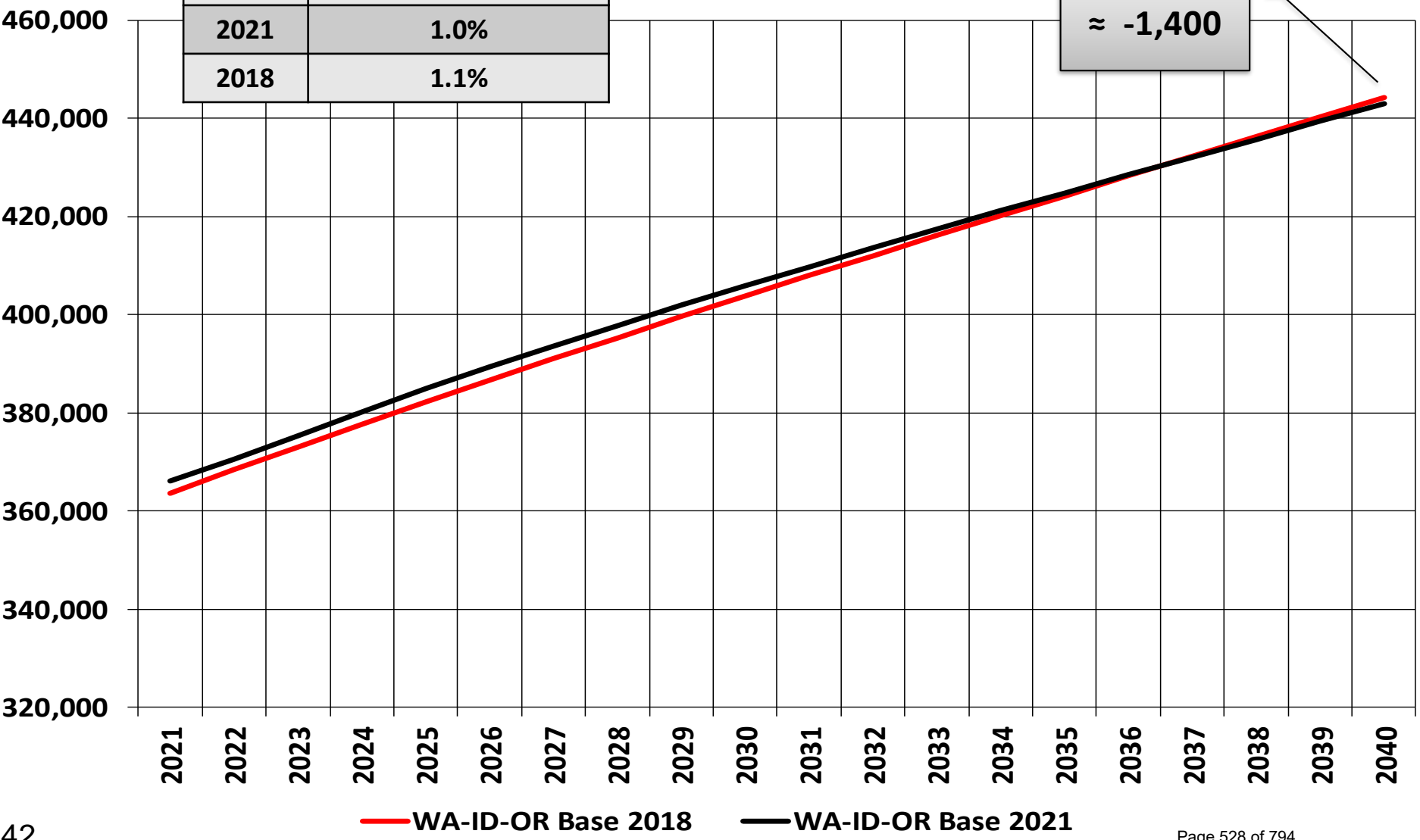

WA-ID Region Firm Customer Range, 2021-2045

Variable	Low Growth	Base Growth	High Growth
WA-ID Customers	0.7%	1.1%	1.5%
WA Population	0.4%	0.7%	1.0%
ID Population	0.8%	1.4%	2.0%
WA-ID Population	0.5%	0.8%	1.2%

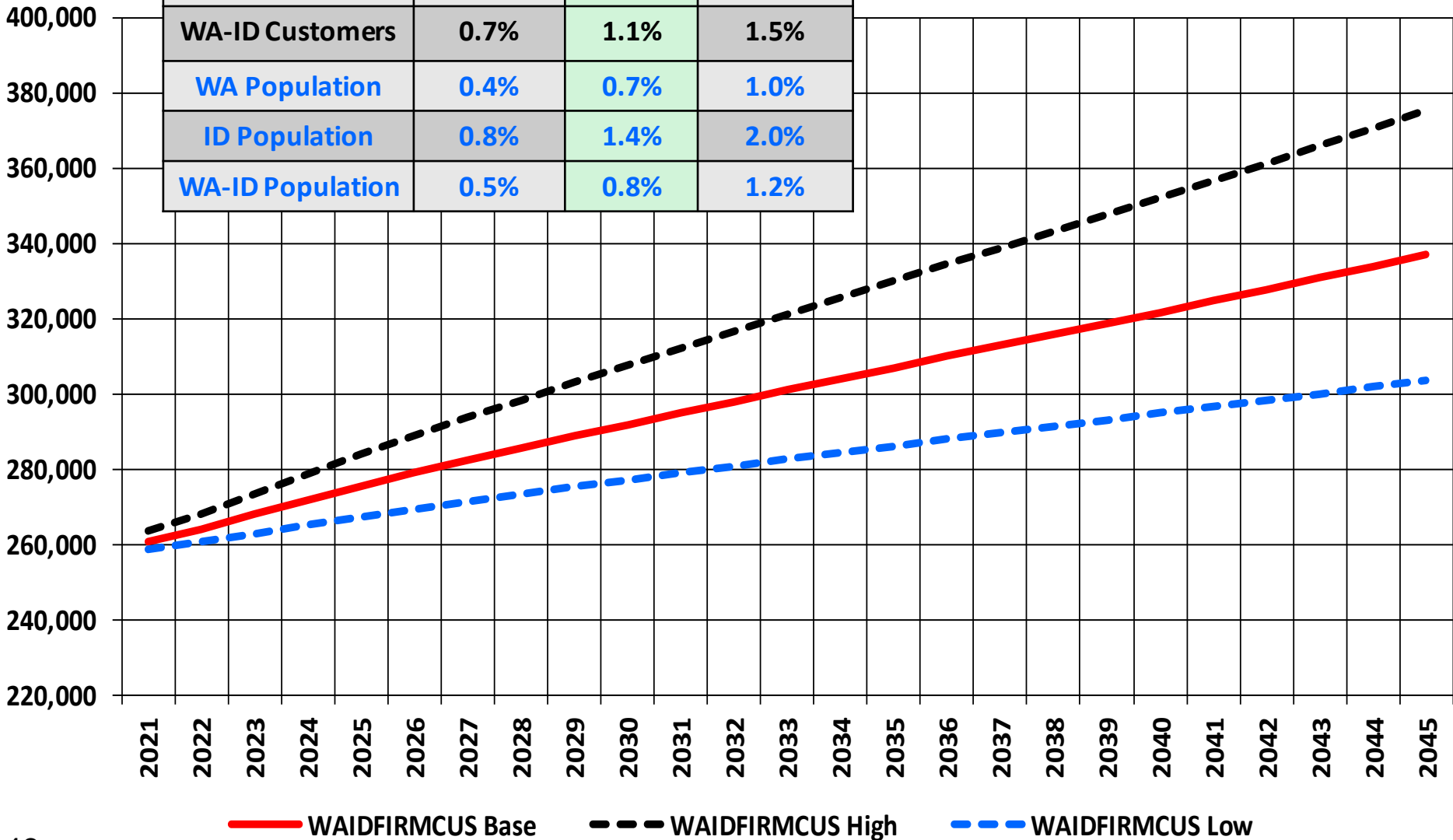

OR Region Firm Customer Range, 2021-2045

Variable	Low Growth	Base Growth	High Growth
Customers	0.5%	0.7%	0.9%
Population	0.3%	0.5%	0.7%

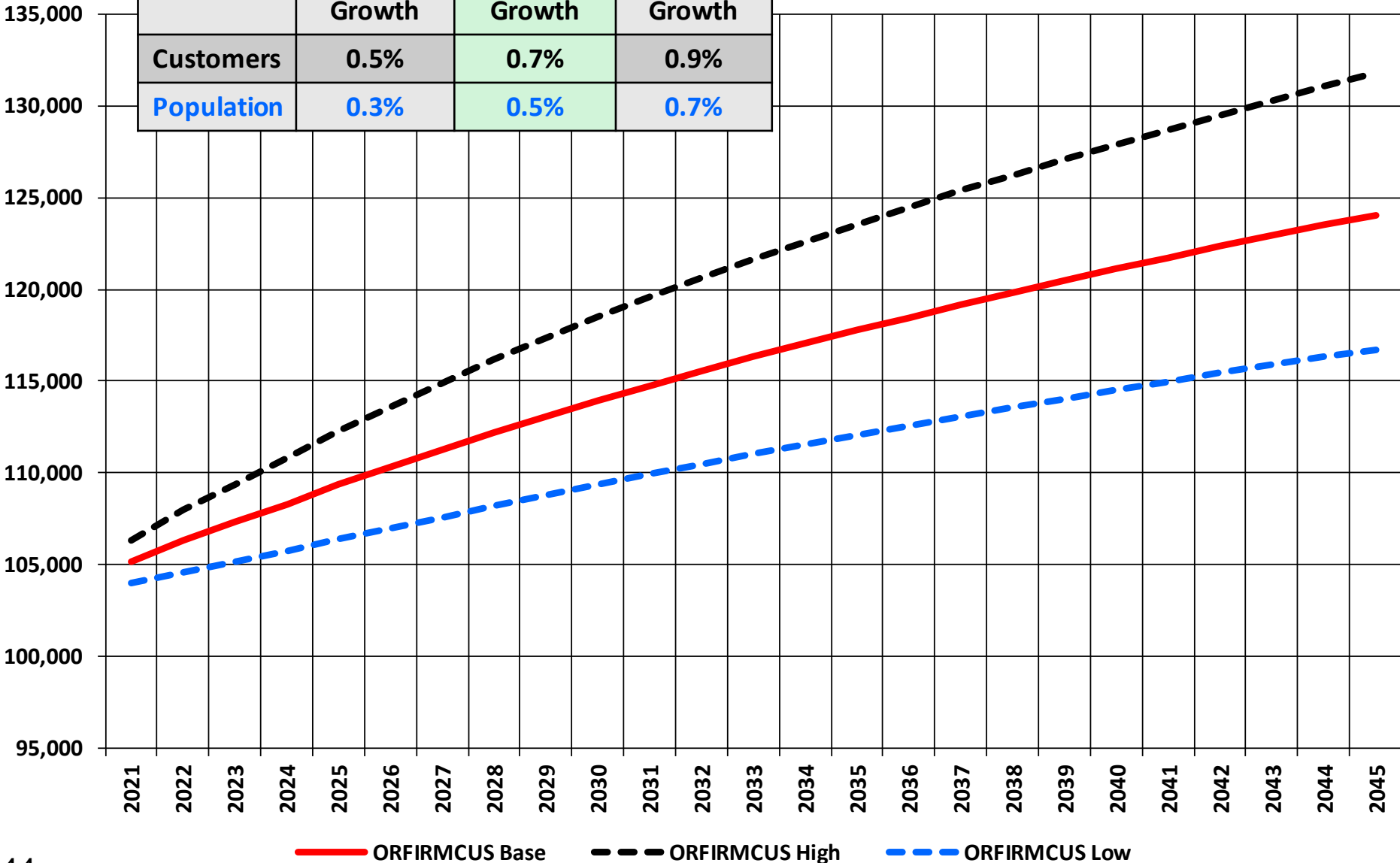

System Firm Customer Range, 2021-2045

Variable	Low Growth	Base Growth	High Growth
Customers	0.6%	1.0%	1.3%
Population	0.4%	0.8%	1.1%

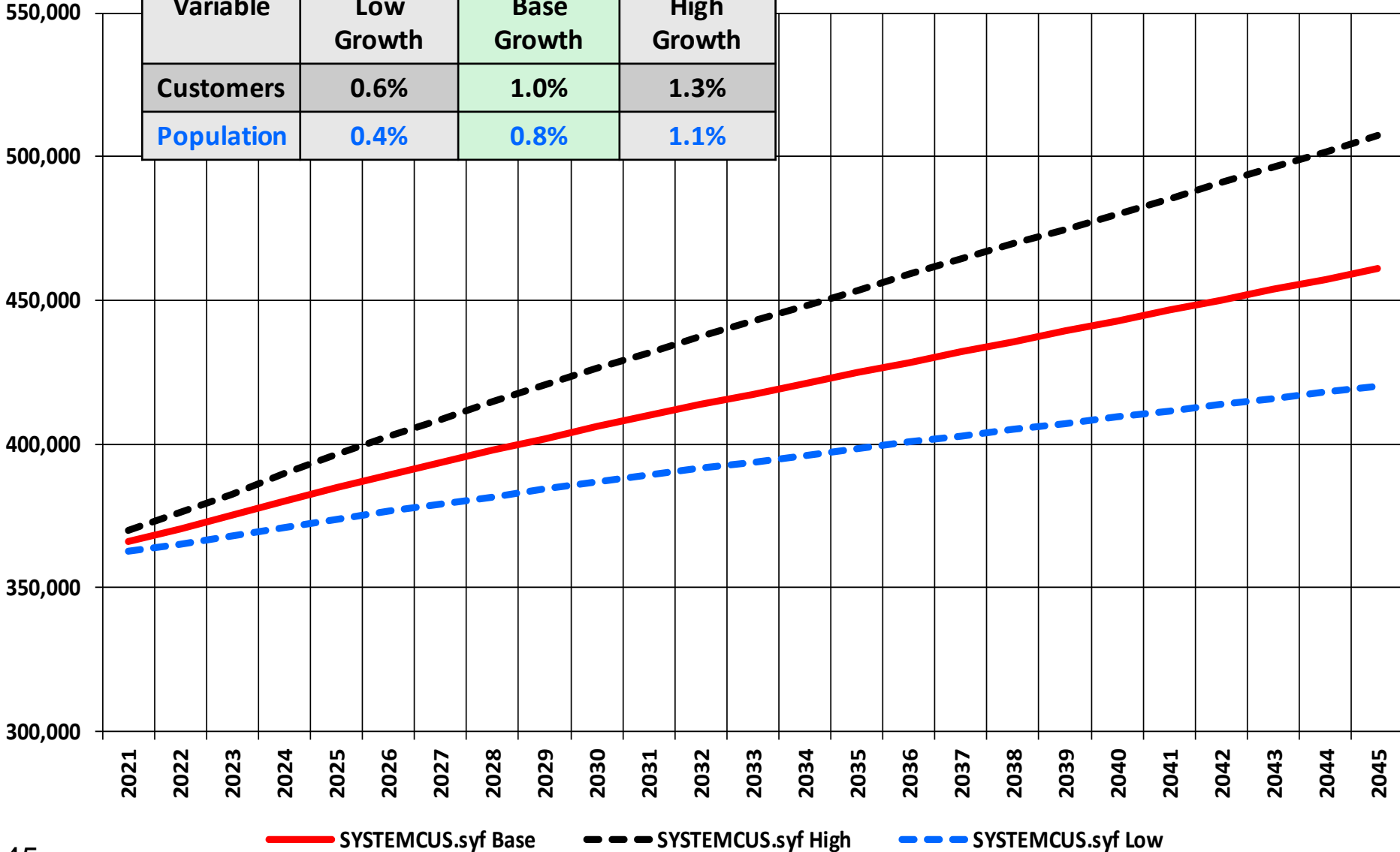

Summary of Growth Rates

System	Base-Case	High	Low
Residential	1.0%	1.4%	0.7%
Commercial	0.5%	0.8%	0.1%
Industrial	-0.8%	2.2%	-3.8%
Total	1.0%	1.3%	0.6%
WA			
System	Base-Case	High	Low
Residential	1.0%	1.3%	0.7%
Commercial	0.4%	0.7%	0.1%
Industrial	-0.8%	1.9%	-3.6%
Total	1.0%	1.3%	0.7%
ID			
System	Base-Case	High	Low
Residential	1.4%	2.0%	0.8%
Commercial	0.4%	1.0%	-0.2%
Industrial	-1.0%	1.8%	-3.4%
Total	1.3%	1.9%	0.7%
OR			
System	Base-Case	High	Low
Residential	0.7%	0.9%	0.5%
Commercial	0.6%	0.8%	0.4%
Industrial	0.0%	4.5%	-10.6%
Total	0.7%	0.9%	0.5%



Avista – 2020 Natural Gas Integrated Resource Plan

Technical Advisory Committee # 3
September 30, 2020

2020 Natural Gas IRP Schedule

TAC 1: Wednesday, June 17, 2020: TAC meeting expectations, 2020 IRP process and schedule, energy efficiency update, actions from 2018 IRP, and a Winter of 2018-2019 review. Procurement Plan and Resource Optimization benefits. fugitive Emissions, Weather Analysis, Weather Planning Standard

TAC 2 (Dual Meeting with Power side): Thursday, August 6, 2020: Market Analysis, Price Forecasts, Cost Of Carbon, Environmental Policies

- Demand Results and Forecasting – August 18, 2020

TAC 3: Wednesday, September 30, 2020: Distribution, Avista's current supply-side resources overview, supply side resource options, renewable resources, Carbon cost, price elasticity, sensitivities and portfolio selection modeling.

TAC 4: Wednesday, November 18, 2020: CPA results from AEG & ETO, review assumptions and action items, final modeling results, portfolio risk analysis and 2020 Action Plan.

Agenda

	Topic Length	Start Time	–	End Time
• Introductions/Agenda	30 minutes	9:00 AM	–	9:30 AM
• Avista and Carbon Reduction	15 minutes	9:30 AM	–	9:45 AM
• Current Supply Side Resources	30 minutes	9:45 AM	–	10:15 AM
• BREAK	15 minutes	10:15 AM	–	10:30 AM
• Renewable Natural Gas	60 minutes	10:30 AM	–	11:30 AM
• Hydrogen	30 minutes	11:30 AM	–	12:00 PM
• LUNCH BREAK	60 minutes	12:00 PM	–	1:00 PM
• Distribution	60 minutes	1:00 PM	–	2:00 PM
• Supply Side Resource Options	30 minutes	2:00 PM	–	2:30 PM
• Carbon Costs/Price Elasticity	30 minutes	2:30 PM	–	3:00 PM
• Sensitivities	30 minutes	3:00 PM	–	3:30 PM



Avista and Carbon Reduction

Jody Morehouse

Director – Natural Gas Supply

Planning for a Deeply Decarbonized Future

Active Energy Policy Environment

- Washington
 - Carbon reduction goal [House Bill 2311](#)
 - RNG/EE [House Bill 1257](#)
- Oregon:
 - RNG [Senate Bill-98](#)
 - Cap and Reduce [Executive Order 20-04](#)

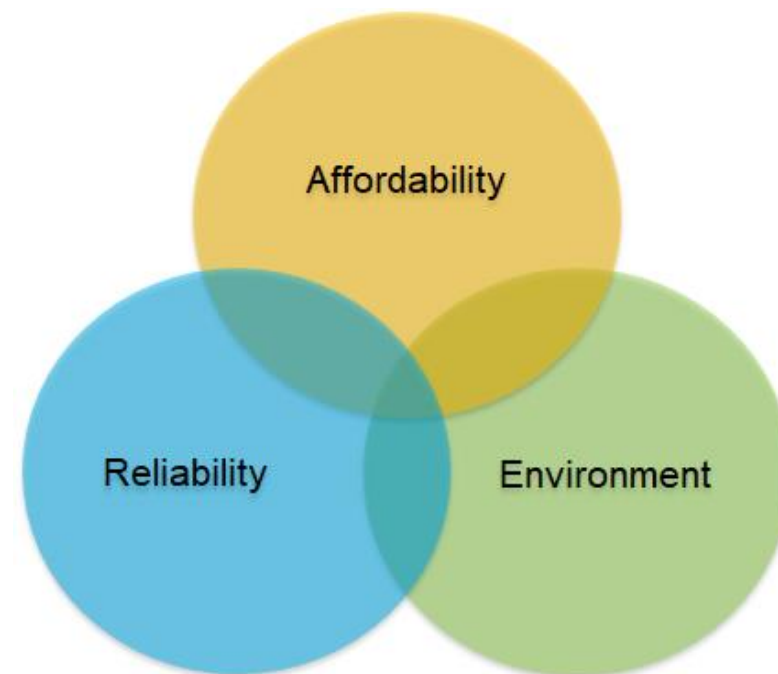

Focus on solutions that balance carbon reduction, affordability, and reliability

Avista's Environmental Objectives

- Build further recognition of Avista's continued commitment to environmental stewardship
- Acquire renewable supplies based on the demand of our customer base and/or policy direction
- Fully account for all costs of natural gas including carbon attributed to upstream emissions
- Continue to engage with state and local governments on all existing and future climate policy
- Increase understanding of how natural gas currently works as part of the energy ecosystem, ensuring that customers have choices for their energy needs that include access to reliable energy at affordable prices
- Demonstrate Avista's leadership in responsibly managing a transition to a cleaner energy mix while being sensitive to customers' and other stakeholders' interests

Natural Gas is an Important Part of a Clean Energy Future

- In the right applications, **direct use of natural gas is best use**
- Natural gas generation provides **critical capacity** as renewables expand until utility-scale storage is cost effective and reliable
- Full electrification can lead to **unintended consequences**:
 - Creates new generation needs that may increase carbon footprint
 - Drives new investment in electric distribution, generation, and transmission infrastructure, causing bill pressure
 - Home and business conversion costs borne by customers
- Customers have paid for a vast pipeline infrastructure that can be utilized for a cleaner future by **transitioning the fuel** and keeping the pipe
- A comprehensive view of the energy ecosystem leads to a **diversified approach to energy supply** that includes natural gas



Benefits of Natural Gas

- **For Customers.** Natural gas is affordable, resilient, and reliable.
- **For Society.** Natural gas is an abundant energy resource produced in North America, which helps lessen our dependency on foreign oil.
- **For Innovation.** Natural gas can play a supporting role in expanding the use of renewable energy sources.
- **For Environment.** Natural gas is the cleanest burning fossil fuel, so it helps reduce smog and greenhouse gas emissions.
- **For Economy.** Natural gas provides nearly a fourth of North America's energy today.





Current Supply Side Resources

Justin Dorr

Resource Manager, Natural Gas Supply

Interstate Pipeline Resources

- The Integrated Resource Plan (IRP) brings together the various components necessary to ensure proper resource planning for reliable service to utility customers.
- One of the key components for natural gas service is interstate pipeline transportation. Low prices, firm supply and storage resources are meaningless to a utility customer without the ability to transport the gas reliably during cold weather events.
- Acquiring firm interstate pipeline transportation provides the most reliable delivery of supply.

Pipeline Contracting

Simply stated: The right to move (transport) a specified amount of gas from Point A to Point B



Contract Types

- Firm transport
 - Point A to Point B
- Alternate firm
 - Point C to Point D
- Seasonal firm
 - Point A to Point B but only in winter
- Interruptible
 - Maybe it flows, maybe it doesn't

Avista's Transportation Contract Portfolio

Avista holds firm transportation capacity on 6 interstate pipelines:

Pipeline	Expirations	Base Capacity Dth
Williams NWP	2025 – 2042 (2035)	290,000
Westcoast (Enbridge)	2026	10,000
TransCanada - NGTL	2024-2046	208,000
TransCanada - Foothills	2024-2046	204,000
TransCanada - GTN	2023-2028	210,000 164,000
TransCanada- Tuscarora	2023	200

Pipeline Overview

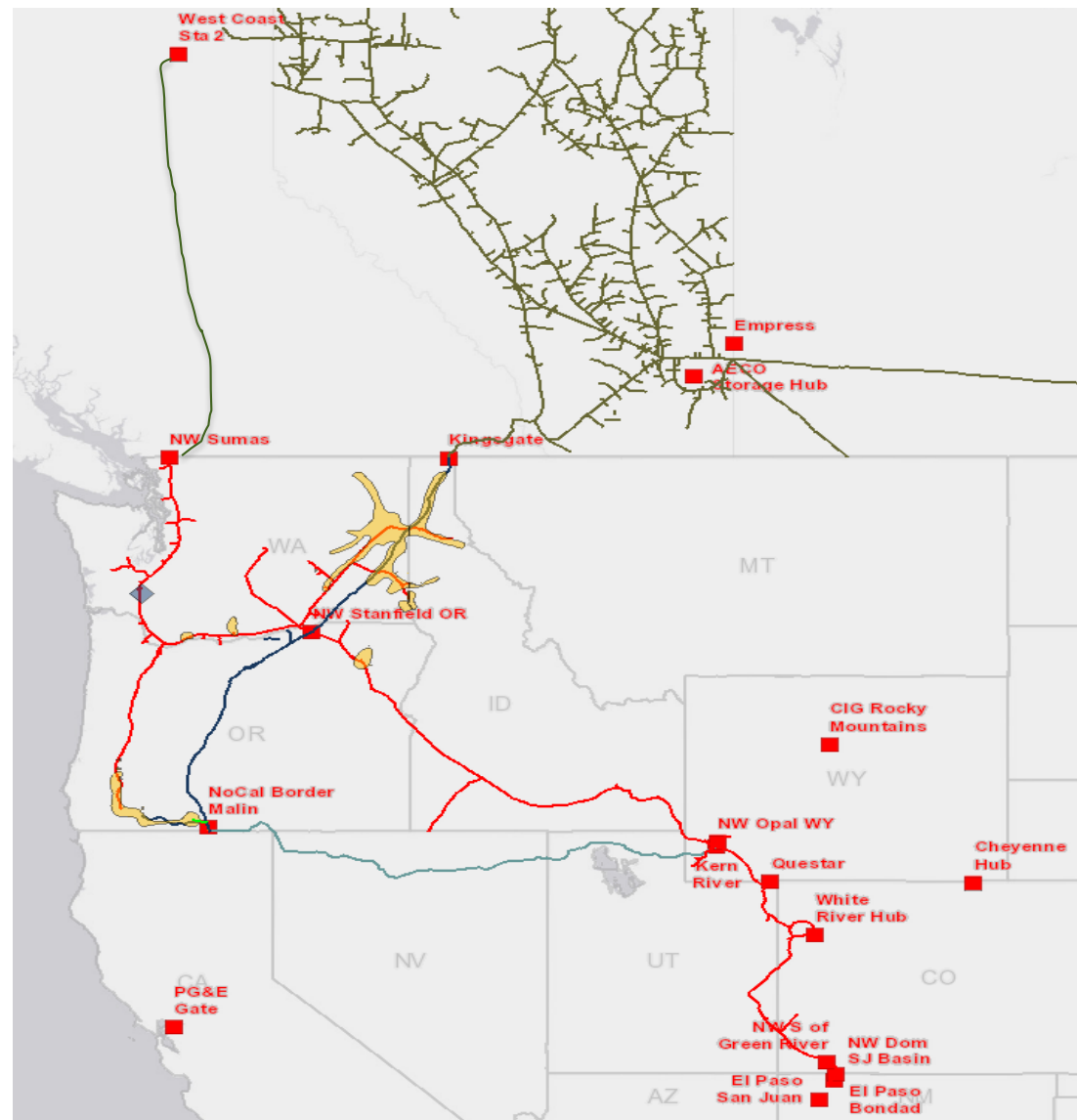

Northwest System – Strategically Located

- > **Low-cost, primary service provider in the Pacific Northwest**
 - 3,900-mile system with 3.8 Bcf/d peak design capacity
 - ~120 Bcf of access to storage along pipeline, with high injection and deliverability capability in market area
- > **Bi-directional design**
 - Provides flexibility (Rockies to market and Sumas to market)
 - Cheapest supply drives flow patterns
 - Provides operational efficiencies through displacement
- > **Supply and market flexibility**
 - 65 receipt points totaling 11.6 Bcf/d of supply from Rockies, Sumas, WCSB, San Juan, emerging shales
 - 366 delivery points totaling 9.7 Bcf/d of delivery capacity



GTN Overview

- Transports WCSB and Rockies natural gas to Washington, Oregon and California
- Approximately 1,377 miles of pipeline
- Kingsgate best efforts receipt capability of approx. 2.87 Bcfd and throughput capacity of approx. 2 Bcfd through Station 14
- Deliveries of up to 1.5 Bcfd to non-California Markets
- Concurrent transport expansions from NIT to Malin:
 - Tranche 1
 - 110 TJ/d (NGTL and FHBC), 100 MDth/d (GTN)
 - November 1, 2022 - Targeted in-service
 - Tranche 2
 - 175 TJ/d (NGTL and FHBC), 150 MDth/d (GTN)
 - November 1, 2023 - Targeted in-service

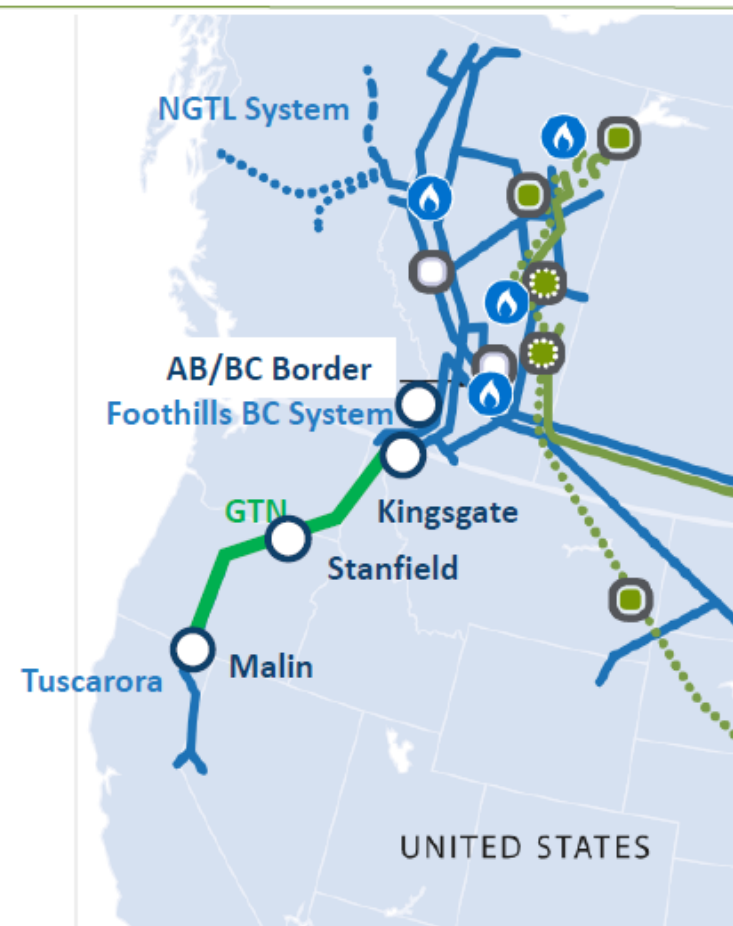

NGTL to Malin West Path expansion



Connecting WCSB supply to key North American markets



Valued transport path for both Supply and End Use Shippers

Concurrent transport expansions from NIT to Malin:

Tranche 1

- 110 TJ/d (NGTL and FHBC), 100 MDth/d (GTN)
- November 1, 2022 - Targeted in-service

Tranche 2

- 175 TJ/d (NGTL and FHBC), 150 MDth/d (GTN)
- November 1, 2023 - Targeted in-service
- **Average** term of awarded capacity:
- **31.3 years** NGTL
- **31.4 years** Foothills BC

FOR DISCUSSION PURPOSES ONLY | SEPTEMBER 2020

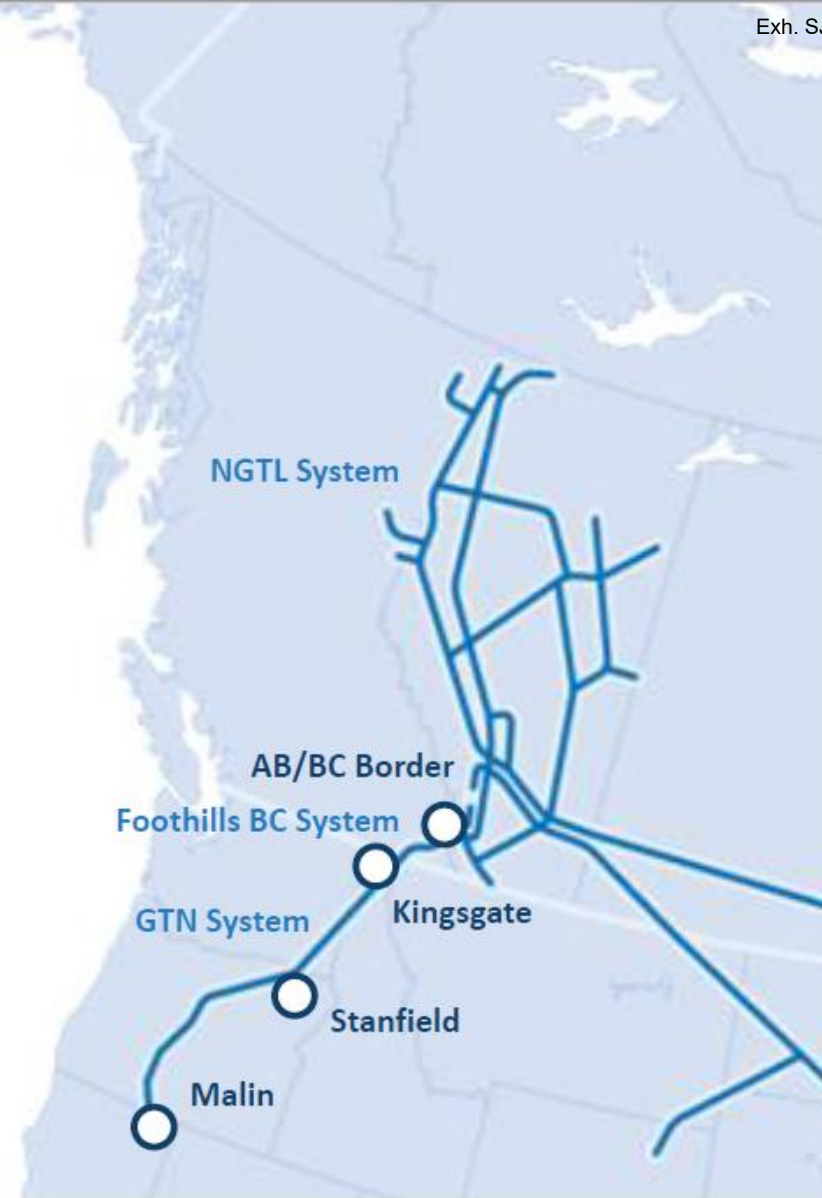

WCSB gas is competitive in key markets, Safety, Toll Competitiveness & Reliability is Our Focus

WCSB (77% TC Energy)

15.6 Bcf/d supply
7.1 Bcf/d intra basin load
8.7 Bcf/d export
4 Bcf/d LNG projected

Pacific

8.3 Bcf/d market
2.2 Bcf/d via TC



NGTL System provides access to **stable** supply source for WCSB end users and allows unique opportunity producers to **compete** in multiple export markets

U.S. Northeast

6.9 Bcf/d market
0.7 Bcf/d via TC

Eastern Canada

4.2 Bcf/d market
2 Bcf/d from WCSB via TC

Chicago (Mid-West)

12.7 Bcf/d end use market
1.6 Bcf/d from WCSB via TC

Flow data based on 2019 Calendar year

FOR DISCUSSION PURPOSES ONLY | SEPTEMBER 2020



1

Storage – A valuable asset

- Peaking resource
- Improves reliability
- Enables capture of price spreads between time periods
- Enables efficient counter cyclical utilization of transportation (i.e. summer injections)
- May require transportation to service territory
- In-service territory storage offers most flexibility

Avista's Storage Resources

Washington and Idaho

Owned Jackson Prairie

- 7.7 Bcf of Capacity with approximately 346,000 Dth/d of deliverability

Oregon

Owned Jackson Prairie

- 823,000 Dth of Capacity with approximately 52,000 Dth/d of deliverability

Leased Jackson Prairie

- 95,565 Dth of Capacity with approximately 2,654 Dth/d of deliverability

The Facility

- Jackson Prairie is a series of deep, underground reservoirs – basically thick, porous sandstone deposits.
- The sand layers lie approximately 1,000 to 3,000 feet below the ground surface.
- Large compressors and pipelines are employed to both inject and withdraw natural gas at 54 wells spread across the 3,200 acre facility.

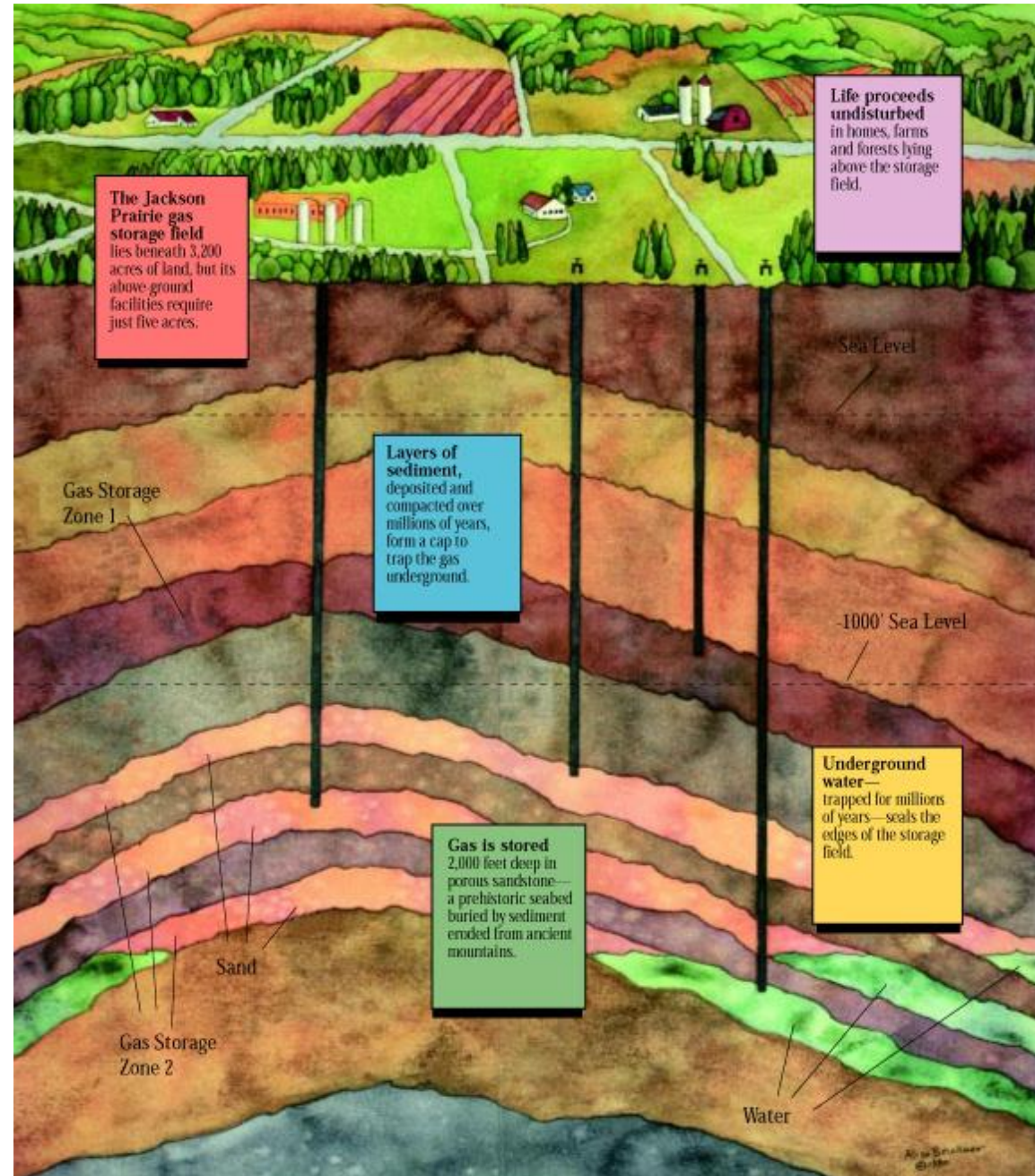



Renewable Natural Gas (RNG)

Michael Whitby, RNG Manager





Advancing RNG at Avista

Avista has been actively preparing to participate in RNG. The following topics covered in this section of the presentation are as follows:

- Renewable Natural Gas (RNG) Explained
- RNG – A Climate Change Solution
- Policy & Regulation
- Industry Reports
- Avista’s Commitment to Carbon Reduction
- Avista’s RNG Program & Team
- Program Considerations
- RNG Market Studies & Voluntary Customer Program
- Pipeline Safety & Interconnection Requirements
- Environmental Attribute Tracking & Banking
- RNG Production Technologies & Project Types
- RNG Opportunities and Challenges
- Cost Effectiveness Evaluation Methodology

Renewable Natural Gas (RNG) Explained

Natural Gas is Critical to a Clean Energy Future



Renewable Natural Gas Explained

Renewable Natural Gas (RNG) is a non-fossil gas resource derived from various renewable waste stream sources including but not limited to landfills, wastewater treatment plants, food waste, and agriculture waste such as dairy farms, and other livestock farms. These feedstocks utilize anaerobic digestion to generate biogas, which in turn can be processed to meet pipeline quality RNG. Forest wood waste can also be converted to biogas via thermal gasification methods and made pipeline ready.

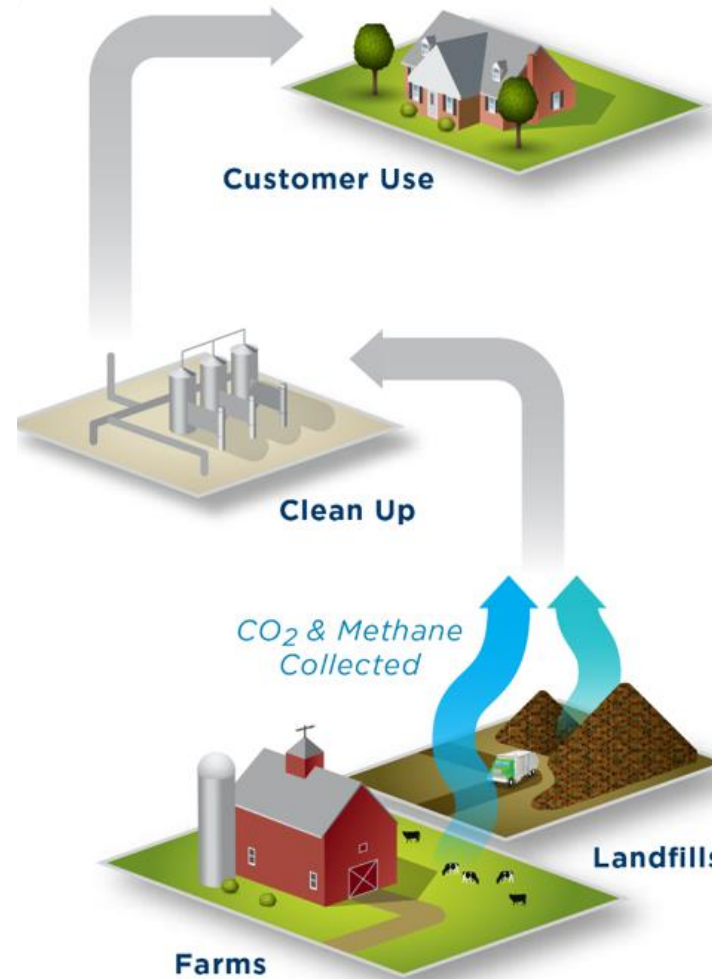

Viable feedstocks that are expected to continually operate and or expand will provide an opportunity for RNG to be produced in perpetuity, and shall serve to displace geologic gas volumes, and capture otherwise fugitive methane. As such, RNG can play an important role in decarbonizing our gas system through RNG customer programs and projects to reduce greenhouse gas (GHG) emissions, and the carbon footprint associated with geologic gas.

RNG is fully interchangeable with conventional natural gas and utilizes the existing natural gas distribution system network to seamlessly serve residential, commercial and industrial end users **without any** additional building improvements, equipment, or special equipment requirements.

RNG – A Climate Change Solution



Natural gas plays critical role for meeting aggressive green house gas (GHG) reductions goals, RNG even more so!

- Advantages of RNG
 - “De-carbonizes” gas stream
 - Gives customers another renewable choice
 - RNG is a strong pathway option for decarbonizing the thermal market
 - RNG utilizes existing infrastructure as it is fully interchangeable with conventional natural gas with no end user equipment modifications or replacement
 - RNG is a more economical solution than electrification which requires the procurement of added renewable electric resources, distribution system upgrades, and has a significant impact to end users due to the necessary replacement of building equipment and systems
 - In the right applications, **direct use of natural gas is best use**
 - Natural gas generation provides **critical capacity** as renewables expand until utility-scale storage is cost effective and reliable



Policy & Regulation:

Washington HB 2580

- RNG study requested by legislature from WA Department of Commerce & WSU Energy Program

Washington HB 1257

- Building efficiency bill that includes RNG
- Requires utilities to offer voluntary RNG programs/products to customers
- Allows utilities to invest in RNG projects and recover the costs

Oregon SB 334

- Directs the Oregon Department of Energy to conduct a biogas and renewable natural gas inventory and prepare a report

Oregon SB 98 & AR 632 Rule Making

- Final rules effective on July 17th 2020
- Allows investment recovery, percent of revenue requirement per year to be determined based on potential project costs & timing, pending petition to participate
- Allows investment in gas conditioning equipment without RFP process



Industry Reports:

Avista is familiar with these relevant industry reports and has utilized them to understand the RNG industry in general as well as the potential in Washington & Oregon

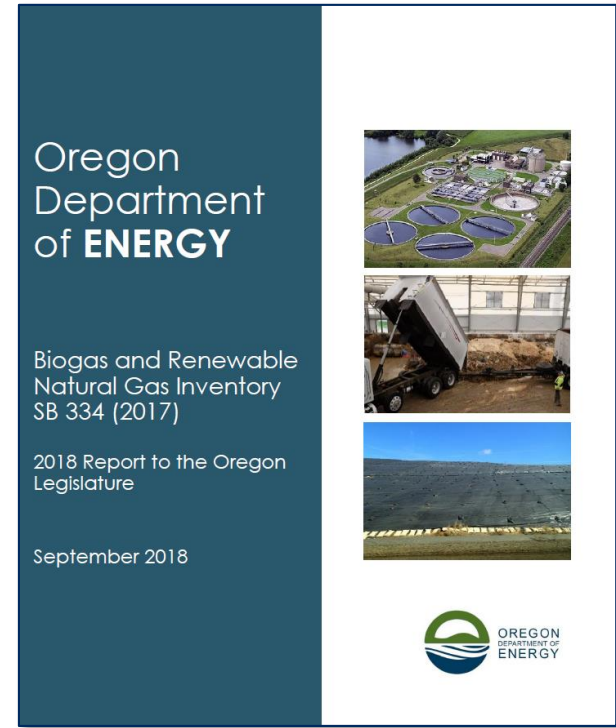
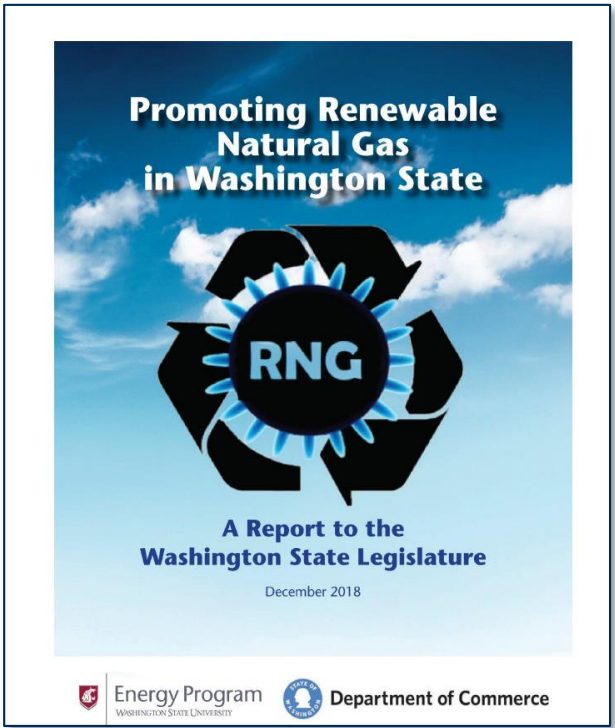
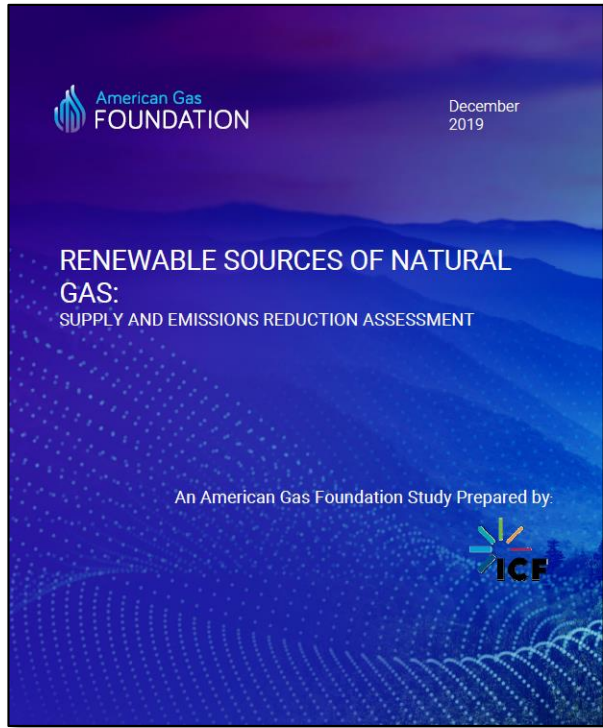



Avista's Commitment to Carbon Reduction

RNG is a Pathway to Decarbonizing the Natural Gas System

- By utilizing waste streams to create green fuel, RNG can play an important role in supporting Avista's environmental strategy
- RNG provides Avista's customers with a new environmentally friendly, low carbon fuel choice, delivered seamlessly via Avista's existing natural gas system



Avista's RNG Program & Team

Avista has been assessing and planning for RNG

- Program Manager in place
- Program Charter in place
- Program Execution Plan drafted
- Participation in the regulatory and rule making process in OR & WA, informal and formal
- Business Development efforts in pursuit of multiple RNG projects continues
- Business Cases developed for consideration in Avista's five year capital planning cycle
- RNG Project accounting established
- Cross-functional team in place to support RNG:
 - Gas Engineering
 - Gas Supply
 - Legal
 - Governmental Affairs
 - Regulatory Affairs
 - Products & Services



Program Considerations

- Evaluate available RNG procurement options
- Pursue potential RNG development opportunities from local RNG feedstock resources under new legislation (Washington HB 1257 & Oregon SB 98)
- Develop an understanding of RNG development cost, cost recovery impacts to customers, resulting supply volumes and RNG costs
- Evaluate potential RNG customer market demands vs. supply
- Participation in rule making and policy:
 - Participation in HB 1257 Policy development
 - Participation in SB 98 Policy Rulemaking via AR 632 informal and formal
 - Cost recovery proposal led by NWGA with input from all four Washington LDC's
 - Collaborative RNG Gas Quality Framework established across four WA LDC's

RNG Market Studies & Voluntary Customer Program



- RNG Commercial Market Study completed in 2019
- RNG Residential Market Survey concluded in September 2020
 - Customers lack understanding of RNG since it is a new concept
 - Customers like the environmental aspects of RNG
 - Customers like to choose their level of participation to manage costs predictably
- Voluntary customer RNG program design will advance based on the studies above
- Estimate voluntary customer program demands
- RNG to be added to Avista's renewables portfolio

Pipeline Safety & Interconnection Requirements



- Avista Gas Quality Specification developed
- Collaborative RNG Gas Quality Framework established across (4) WALDC's
- Avista Interconnection Agreement template developed
- Avista Study Agreement and RNG Producer review process template developed





Environmental Attribute Tracking & Banking

Under OR SB 98 the M-RETS system has been selected to track RNG environmental attributes. Other jurisdictions including Washington may also select this system

- 1 Renewable Thermal Certificate (RTC) = 1 Dekatherm (Dth) of RNG
- Transparent electronic certificate tracking
- Not a certification entity

RTC Creation Process

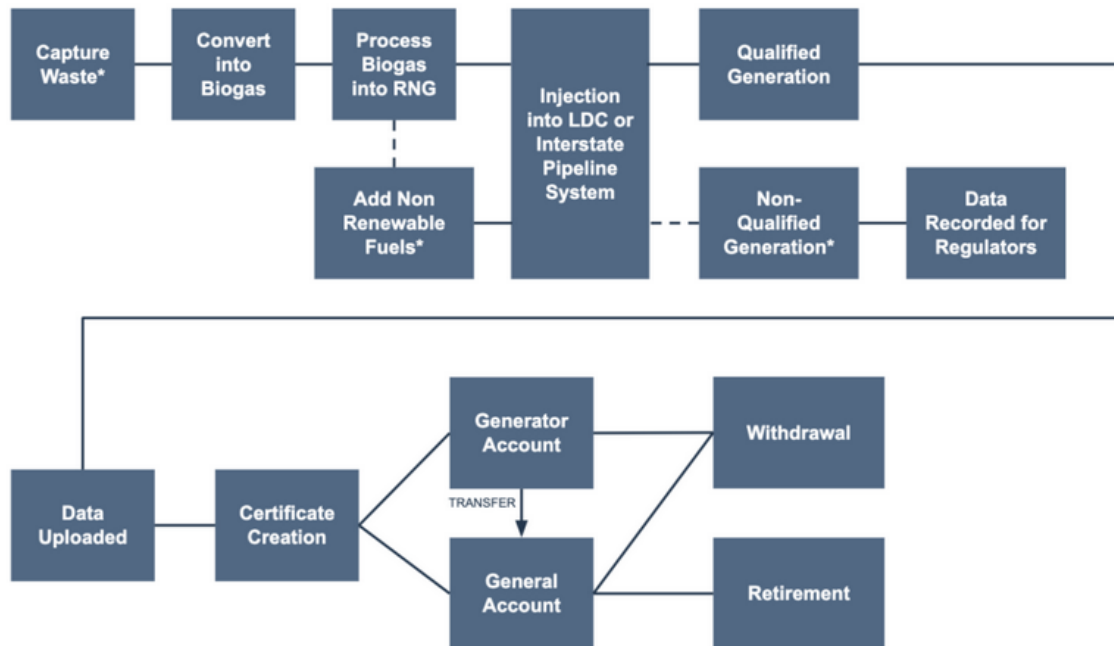

What Does an RTC Look Like?

RTC Information

Dekatherm (Dth) Renewable Thermal = 1 Renewable Thermal Certificate

Certificate Details include:

- Serial Number (See Example)
- Account
- Project
- Thermal Resource
- Feedstock
- Vintage
- Location
- Quantity

Carbon Pathways (If Applicable)
IRE Verification (If Applicable)

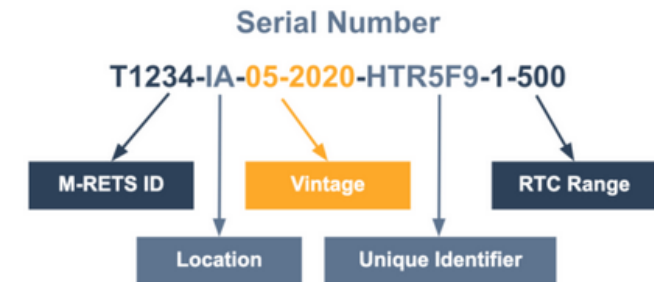



RNG Production Technologies & Project Types

Avista is actively evaluating a handful of potential Anaerobic Digestion Projects throughout Washington and Oregon.

RNG Production Technologies

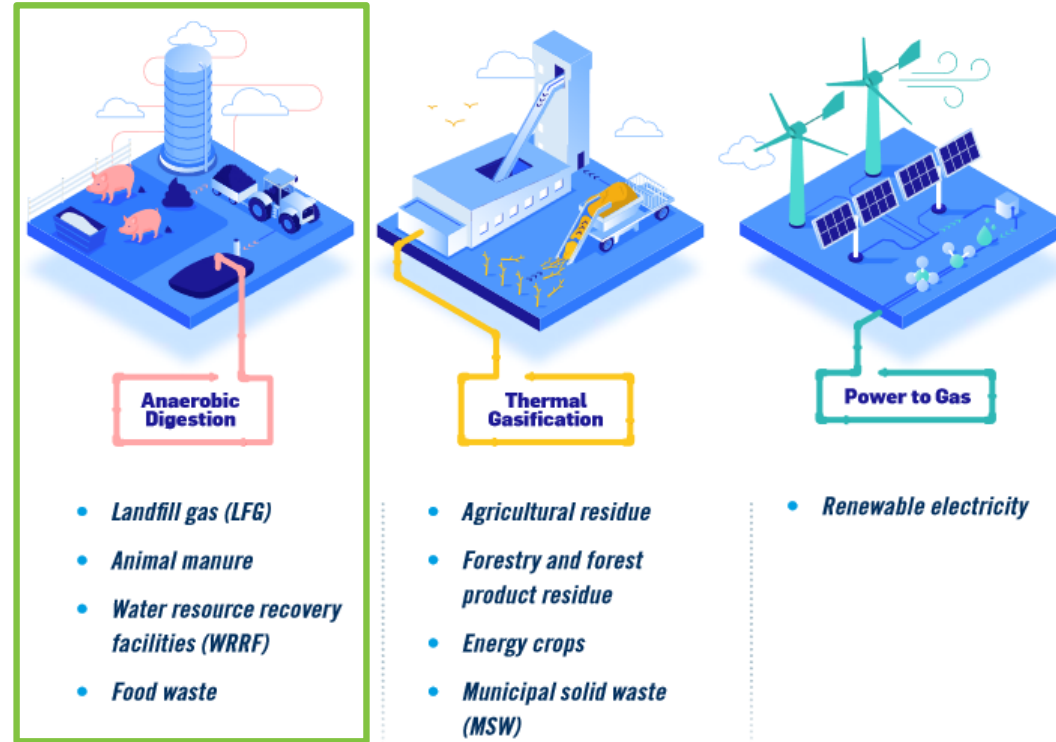

RNG Technologies :

- Conventional RNG: Amine scrub, membrane separation, water wash, PSA
- Hydrogen blending



RNG Opportunities & Challenges

California RNG market (\$30+/Dth v. \$2/Dth)

- Vehicle emission incentives shut-out other potential end users
- Producers see the pot of gold in Federal RIN & California LCFS markets
- RNG supplier cost volatility

Financing for producers

- RIN market is volatile
- No forward pricing for RNG RTC's in carbon market
- Vehicle market may be approaching saturation in CA
- Environmental attribute value for local markets is undefined

RNG Opportunities & Challenges



Utility RNG Projects

- Feedstock owners can now partner with LDC's to cultivate new RNG projects
- Feedstock owners wiliness to partner with the utility's cost of service model. This is a foreign concept to feedstock owners that seek highest value for their biogas
- LDC's are credit worthy partners offering long term off-take contracts to feedstock owners
- Each RNG project is unique with respect to capital development costs & resulting RNG costs
- Each RNG project will vary in size, location and distance to interconnection pipeline, feedstock type, gas conditioning equipment and requirements and operating costs
- Economies of scale – Low volume biogas opportunities face economic challenges
- New RNG Projects can take 2-3 years to develop
- Customers have paid for a vast pipeline infrastructure that can be utilized for a cleaner future by **transitioning the fuel** and keeping the pipe



RNG Opportunities & Challenges

RNG \$ per Dth/MMBtu

Avista Owned and Operated	ID - WA 2035 Premium Estimate (\$ / Dth)
RNG - Landfills	\$7 - \$10
RNG - Waste Water Treatment Plants (WWTP)	\$12 - \$22
RNG - Agriculture Manure	\$28 - \$53
RNG - Food Waste	\$29 - \$53

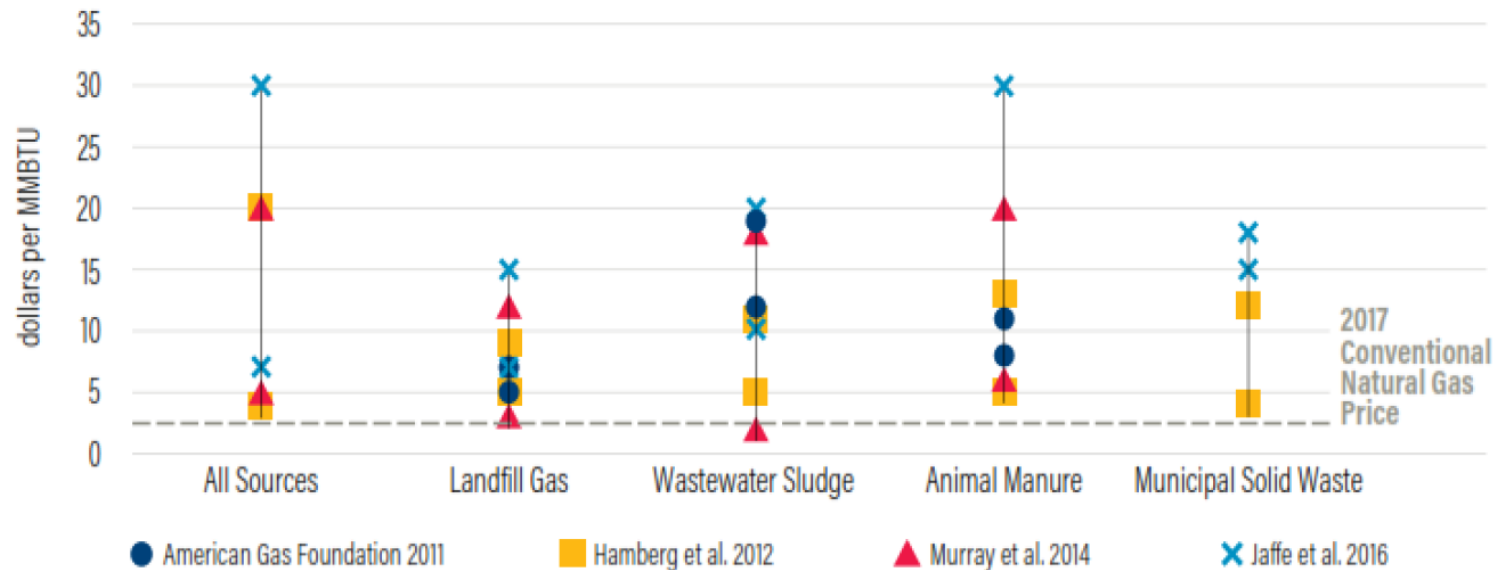

Source: Promoting RNG in WA State



RNG Opportunities & Challenges

Carbon Intensity will play a role in how the environmental attributes / Renewable Thermal Certificate (RTC) values will be determined

Fuel Pathway	Carbon Intensity $\frac{gCO_2e}{MJ}$
Diesel*	102.01
Gasoline*	99.78
Fossil CNG [†]	78.37
Landfill CNG [†]	46.42
WWTP CNG*	19.34
MSW CNG*	-22.93
Dairy CNG [‡]	-276.24

*California Code of Regulation Title 17, §95488, Table 6. Carbon intensity for WWTP is the average of two WWTP pathways.

[†]California Code of Regulation Title 17, §95488, Table 7.

[‡]Method 2B Application CalBio LLC, Dallas Texas, Dairy Digester Biogas to CNG.

RNG Opportunities & Challenges

RNG RTC values within the utility construct cannot compete with the RNG values driven by the RFS RIN & LCFS markets

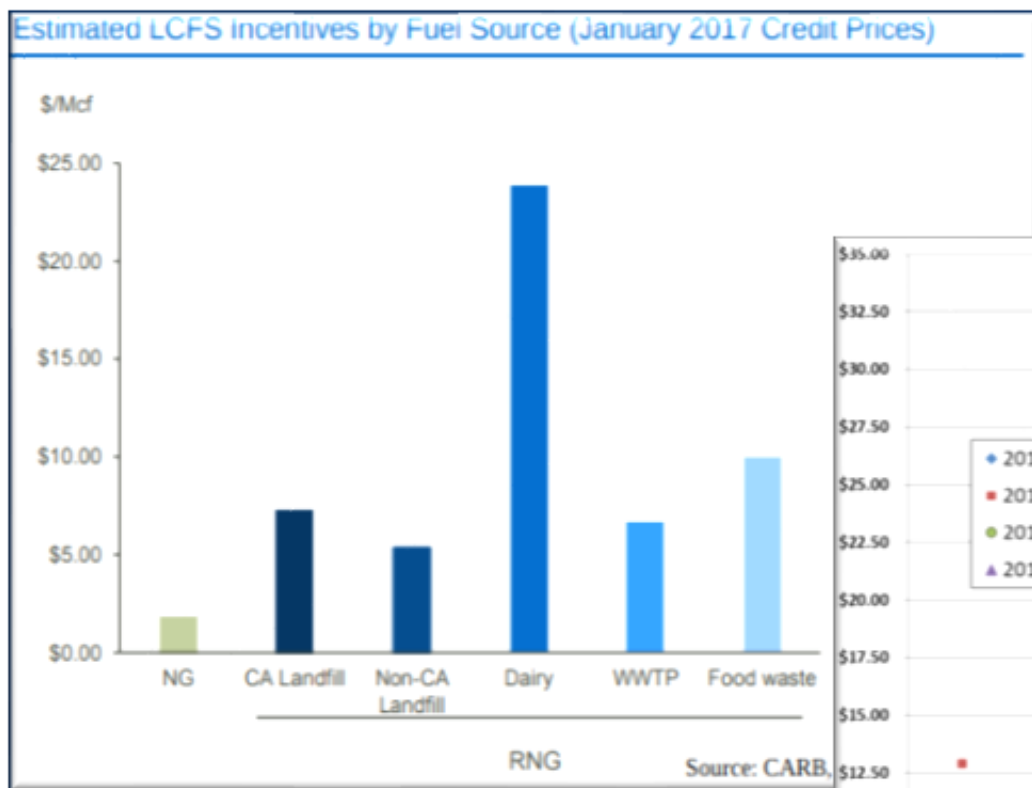

Source: CARB

RIN = renewable identification number

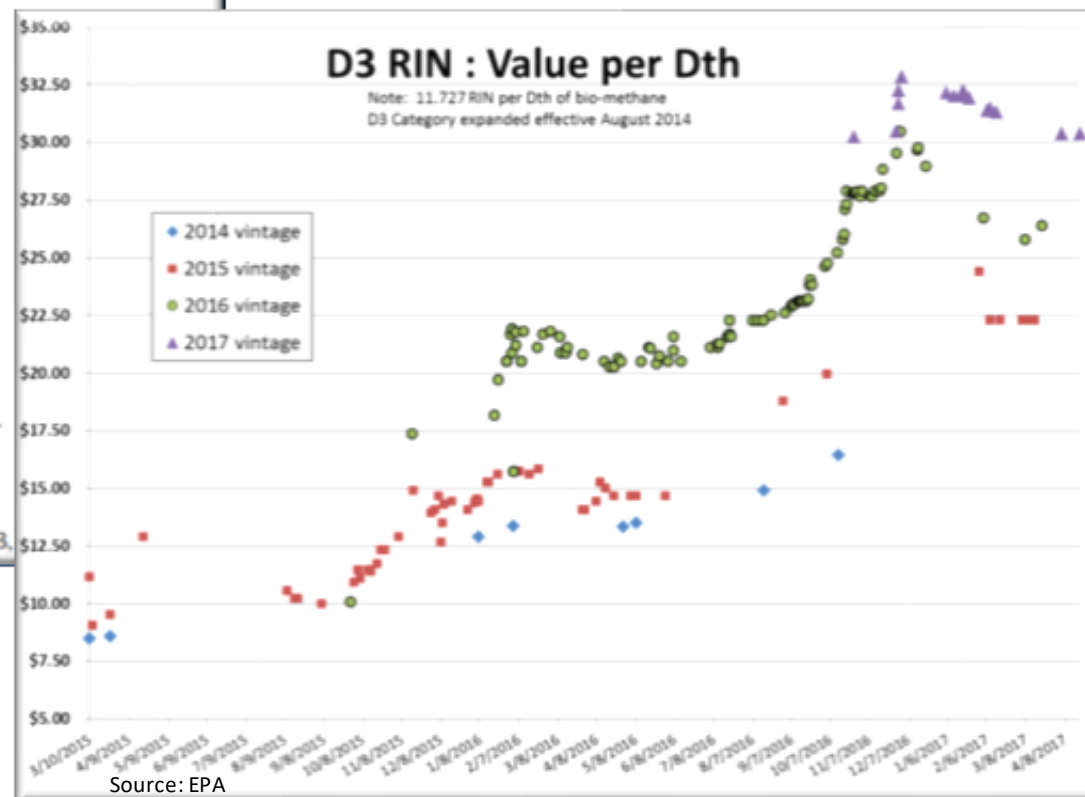

Source: EPA



RNG Opportunities & Challenges

WA RNG Report (HB 2580) – Utility’s have the opportunity to leverage the remaining RNG opportunities to decarbonize the natural gas system

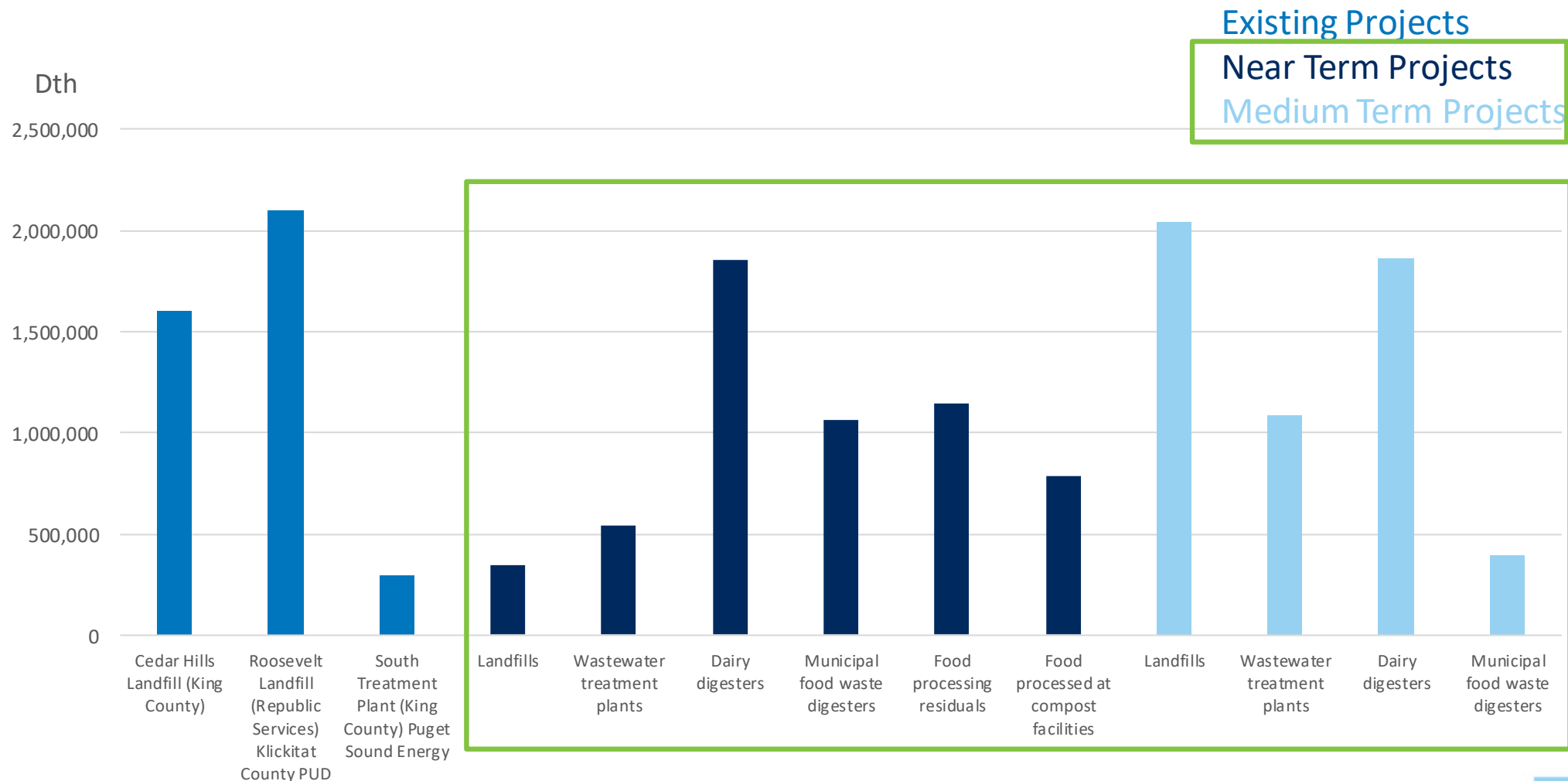

WSU Energy Program, Harnessing Renewable Natural Gas for Low-Carbon Fuel: A Roadmap for Washington State

*Released December 1, 2018

Cost Effectiveness Evaluation Methodology

Developing the Methodology....a work in process

- Avista is creating a cost effectiveness evaluation methodology for evaluating RNG projects. The following slides are a snapshot of Avista's work in progress.
- The methodology shown is derived from OPUC UM2030, also referenced in the OPUC SB 98 AR 632 Rulemaking
- The evaluation method shown herein is subject to input, refinement and reconsideration.





Hydrogen

Tom Pardee
Planning Manager, Natural Gas Supply

Hydrogen

- The energy factor of H2 Low Heating Value (LHV) is roughly equivalent to a gallon of gasoline or 114,000btu
 - This equates to 8.78 kg of H2LHV per Dth
- Most H2 is currently made from reforming natural gas
 - The energy can come from Nuclear (Pink), Renewables (Green) or Fossil fuels (Grey)
- High cost (currently) when compared to energy in a Dth combined with current prices of natural gas
- Hydrogen can only be stored in the pipeline as a % of gas or combined with a carbon source to produce methane.
- Hydrogen is lighter than air and diffuses rapidly (3.8x faster than natural gas) making it more difficult to contain

PtG Process

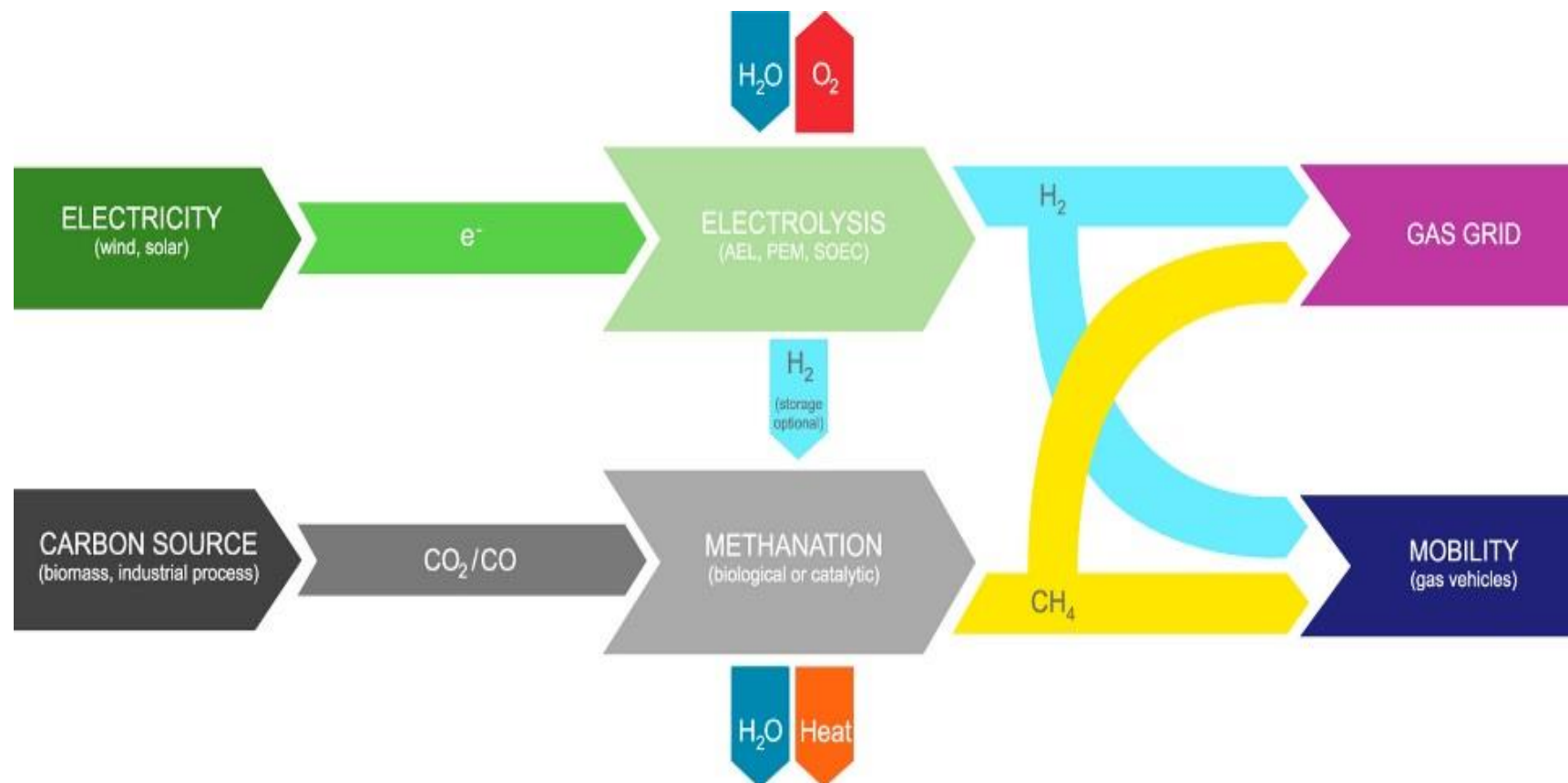

Power to Gas

- Power to Gas (PtG) is a process using power to separate water into hydrogen and oxygen
- Hydrogen can be stored, as a % of gas, in the existing gas grid or used in the mobility sector (blend up to 20%)
- PtG can help to balance excess power from intermittent sources like wind and solar
- PtG can decarbonize the direct use of natural gas
- PtG economics will advance as more renewables are added and the technology matures
- Short term and seasonal energy storage
- Stored in the existing gas pipeline



PtG Benefits

Benefits

- Cleans up the grid using excess power
- Stores the energy for future use in the natural gas pipelines/infrastructure utilizing customer owned resources and are currently available
- Hydrogen is relatively safe as if it is released it quickly dilutes into a non-flammable concentration

Current Renewable Hydrogen Price estimates

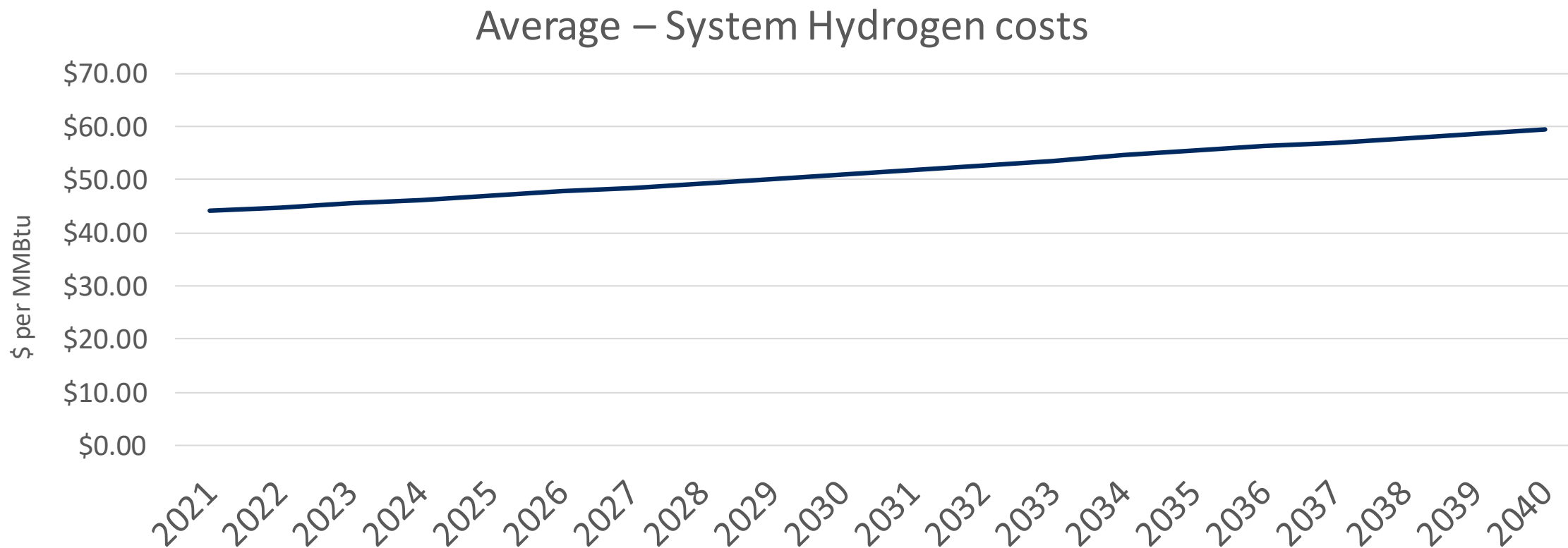

*Assumes Avista owned resources





Distribution Overview

Terrence Browne

Sr. Gas Planning Engineer, Gas Engineering

Mission

- Using technology to plan and design a safe, reliable, and economical distribution system

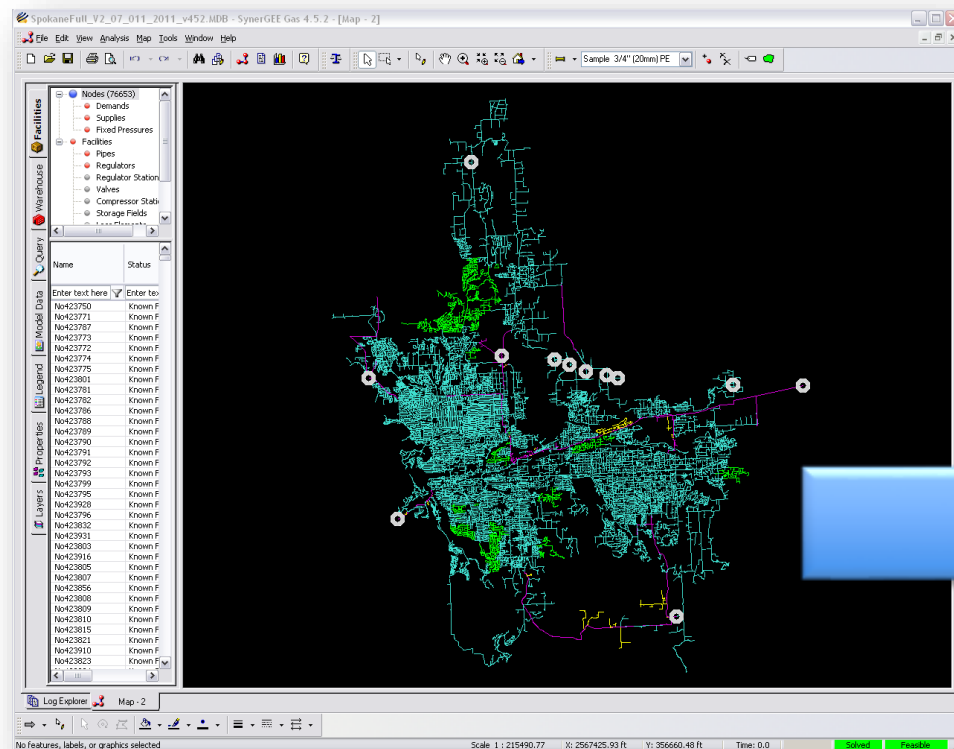

Gas Distribution Planning

- Service Territory and Customers
- Scope of Gas Distribution Planning
- SynerGi Load Study Tool
- Planning Criteria
- Interpreting Results
- Long-term Planning Objectives
- Monitoring Our System
- Communicating Solutions
- Gate Station Capacity Review
- Project Examples

Service Territory and Customer Overview

- Serves electric and natural gas customers in eastern Washington and northern Idaho, and natural gas customers in southern and eastern Oregon
 - Population of service area 1.5 million
 - ▶ 385,000 electric customers
 - ▶ 360,000 natural gas customers

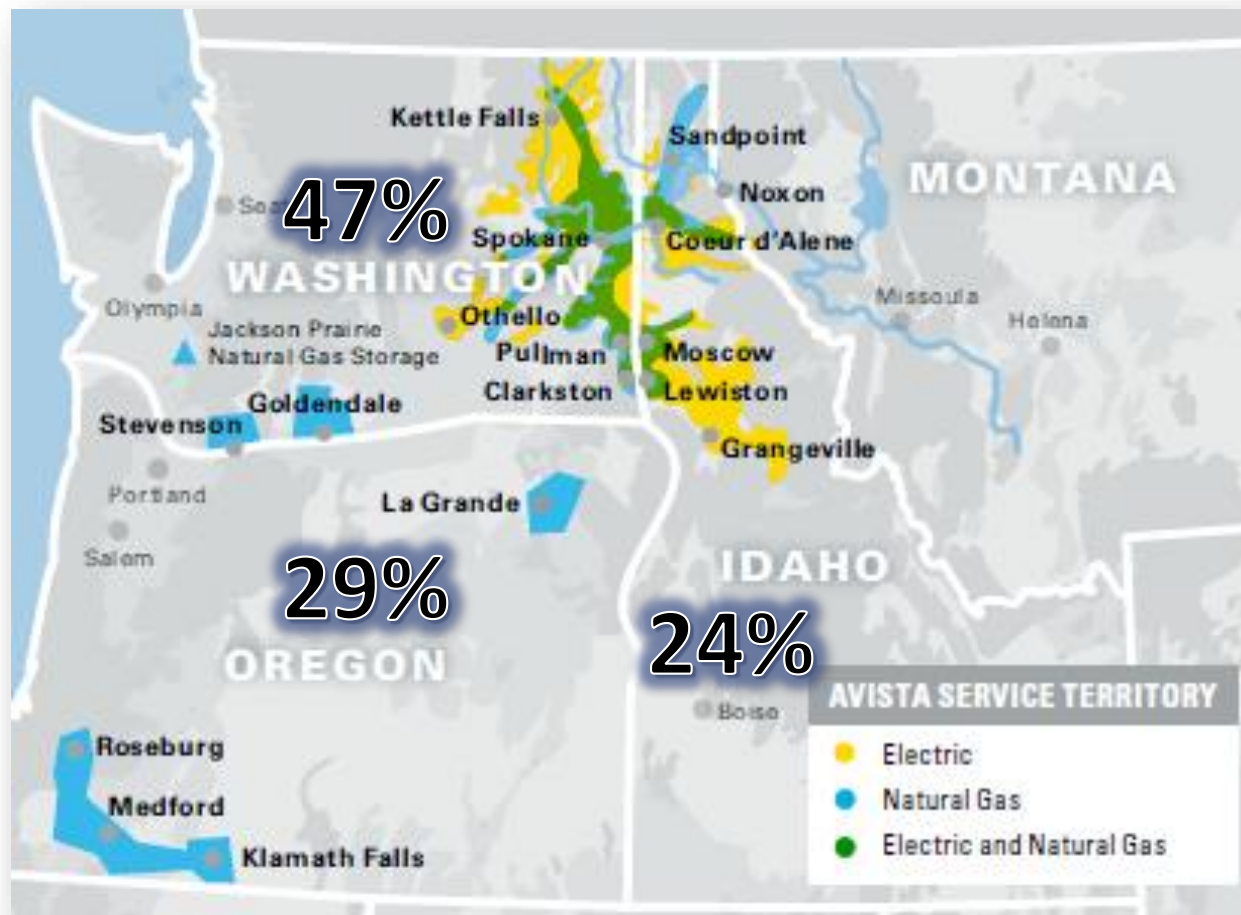

Seasonal Demand Profiles

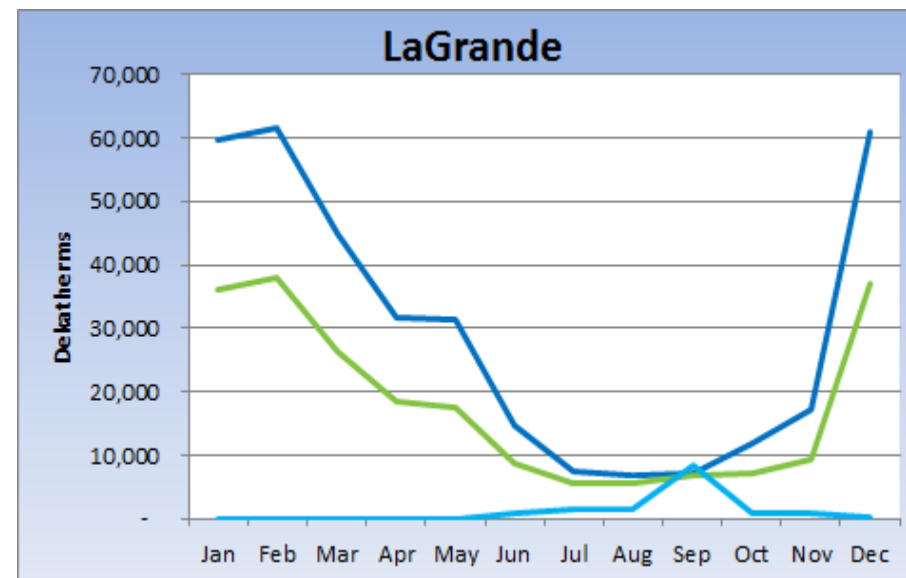
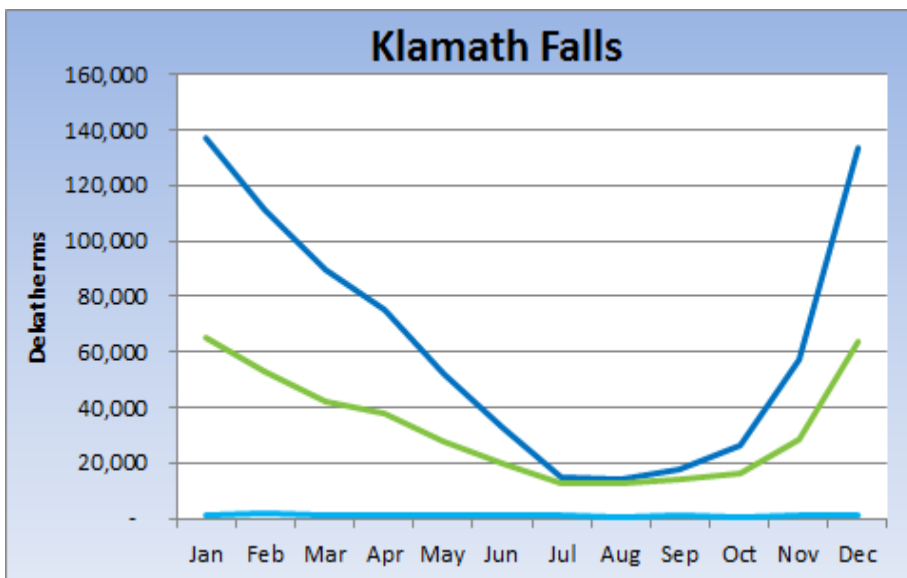
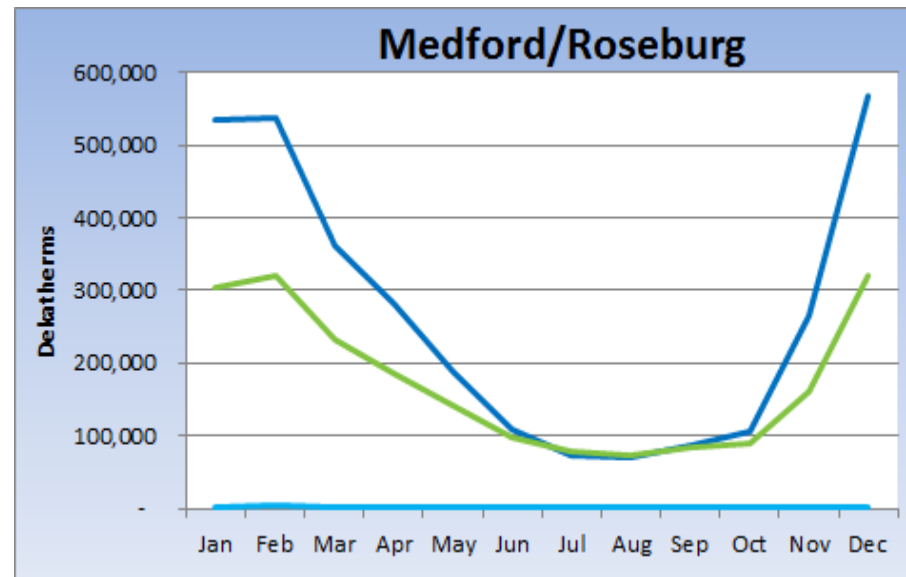
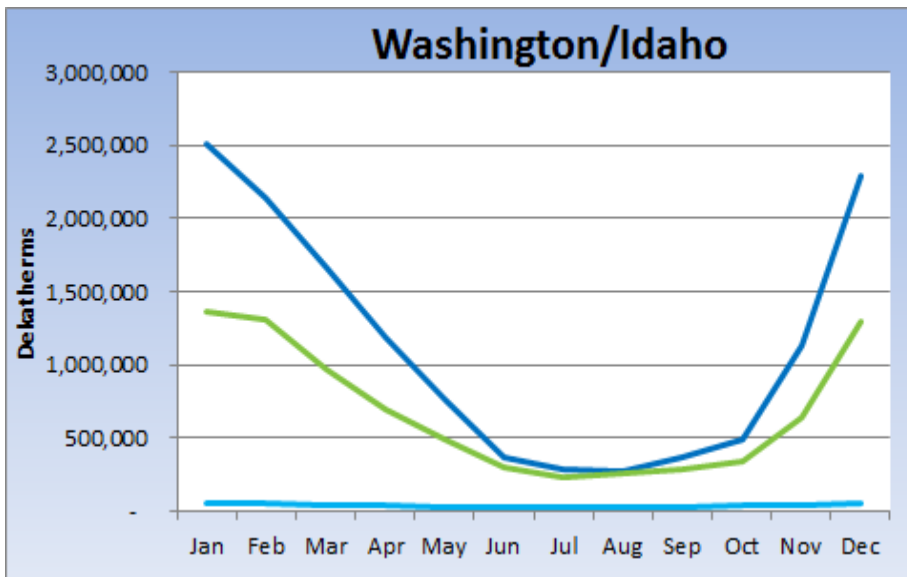

— Residential — Commercial — Industrial



Our Planning Models

- 120 cities
- 40 load study models

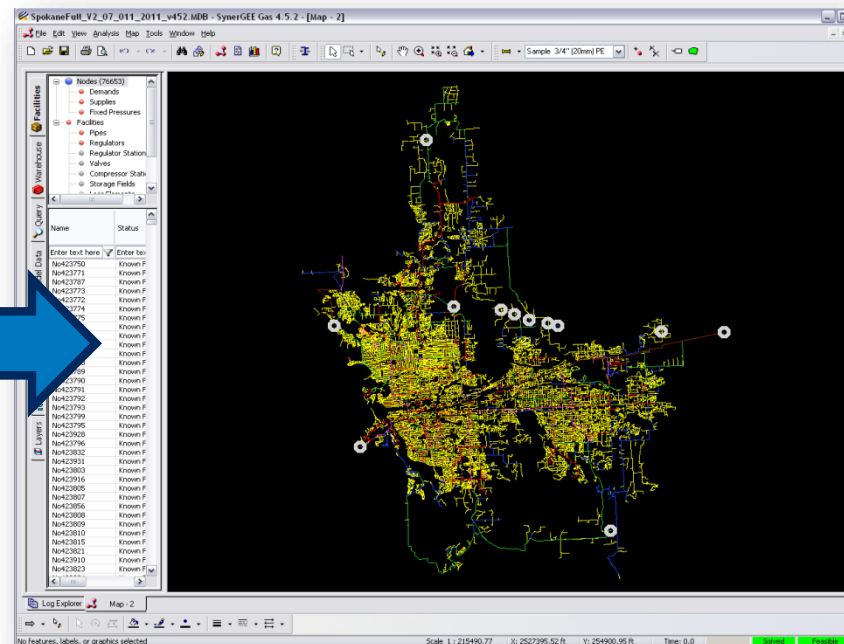
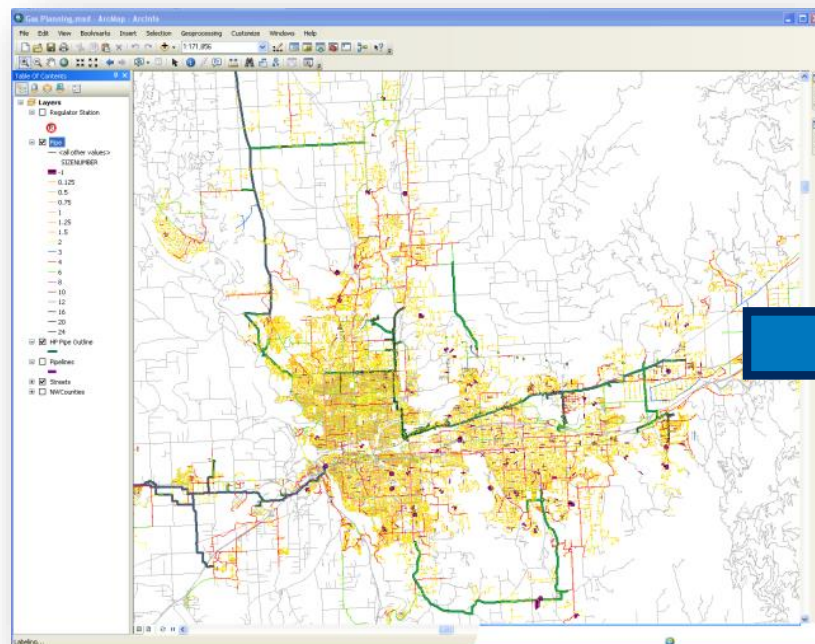

5 Variables for Any Given Pipe

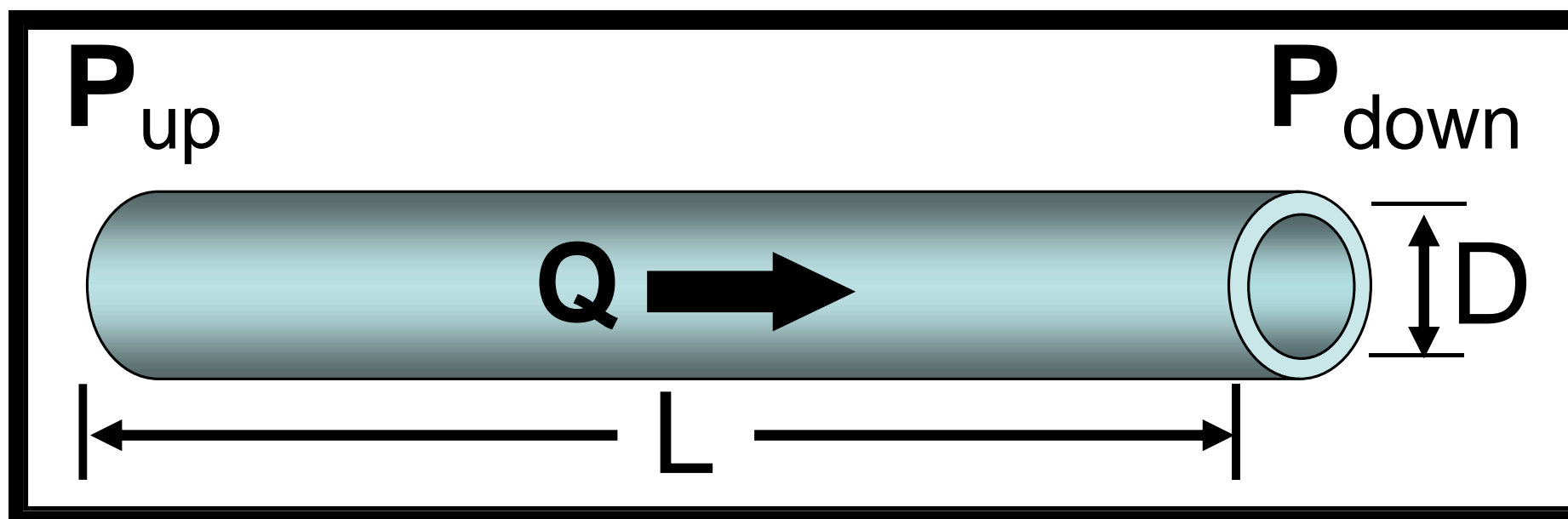

Scope of Gas Distribution Planning

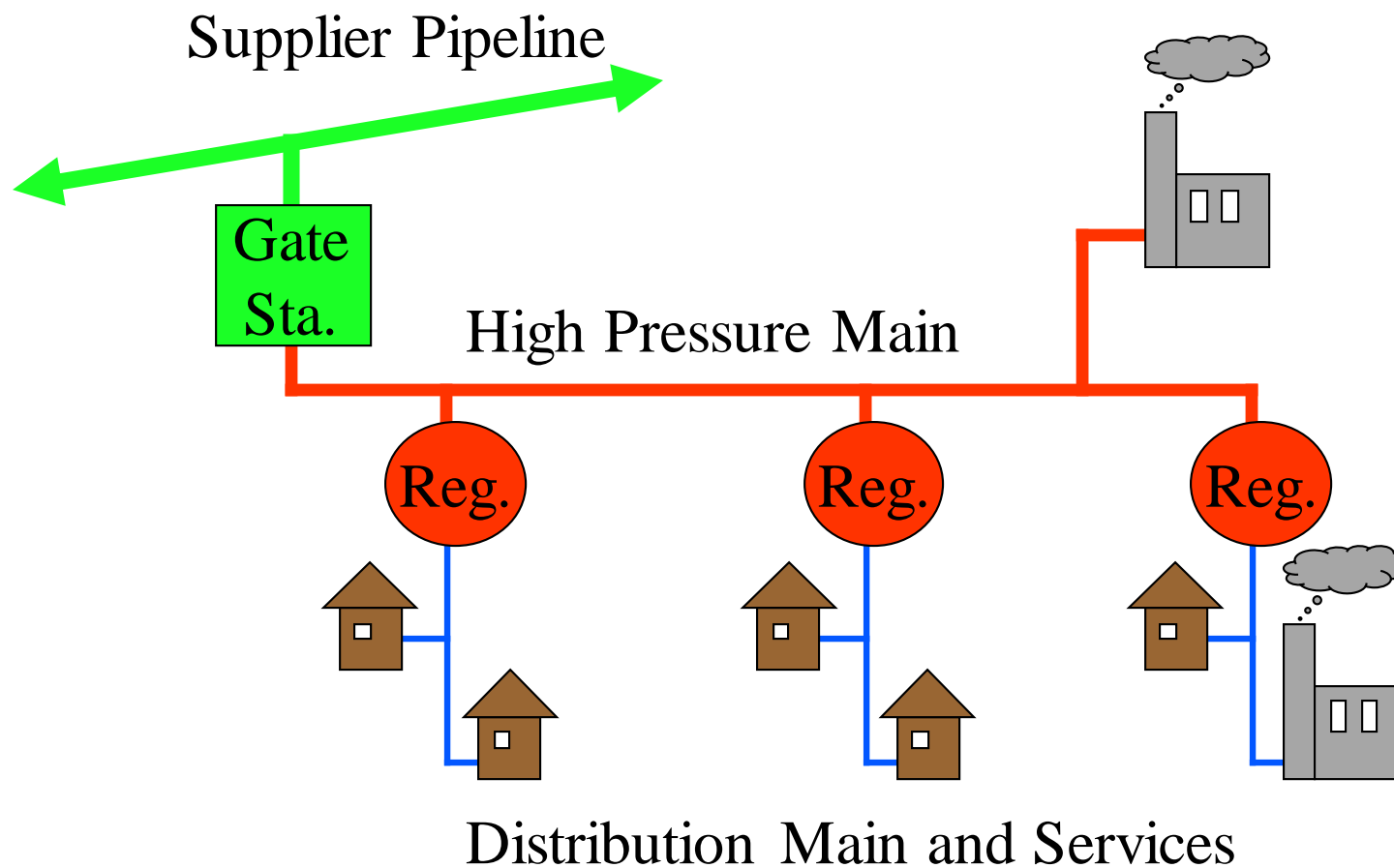

Scope of Gas Distrib. Planning cont.

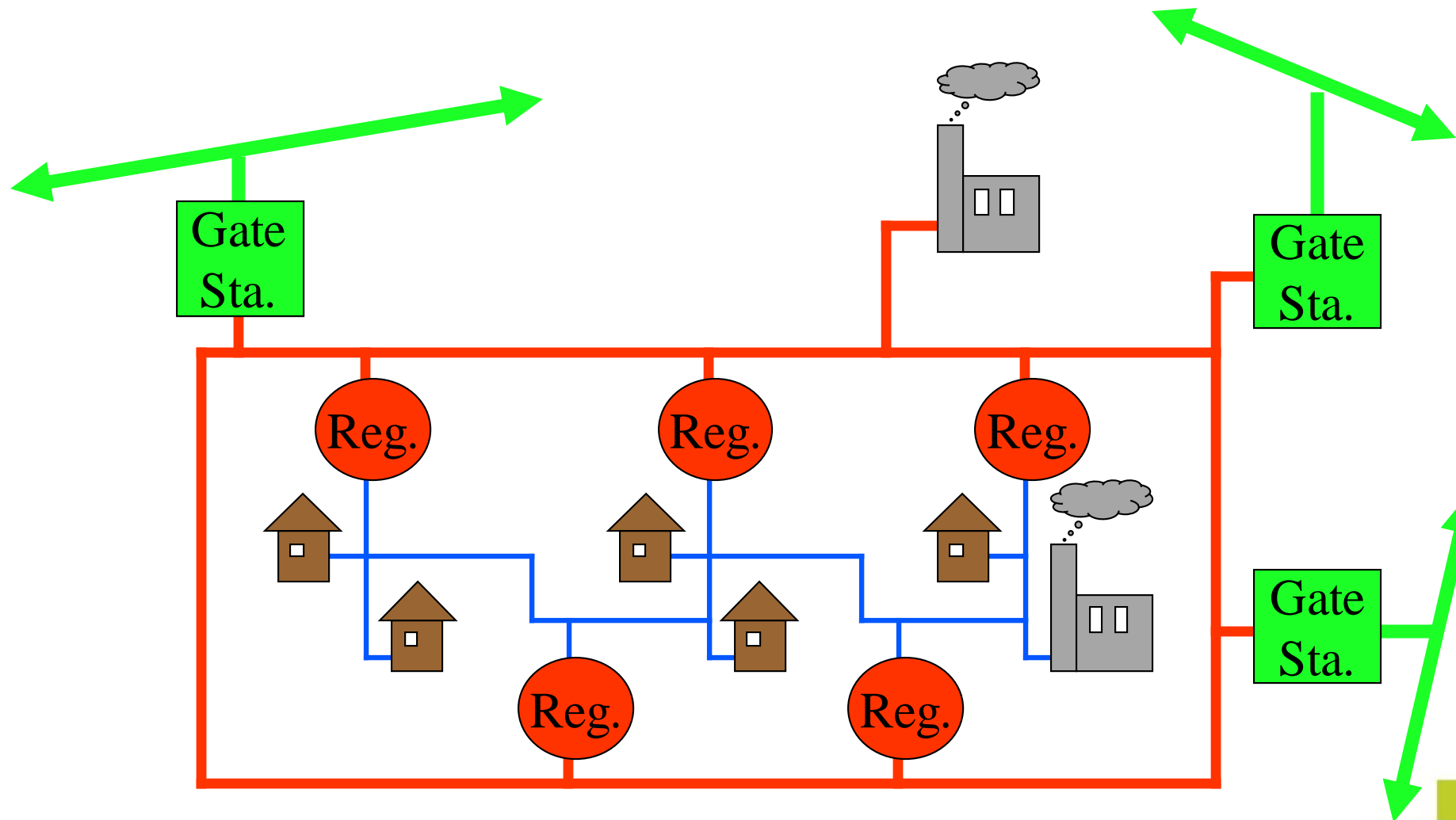

SynerGi (SynerGEE, Stoner) Load Study

- Simulate distribution behavior
- Identify low pressure areas
- Coordinate reinforcements with expansions
- Measure reliability

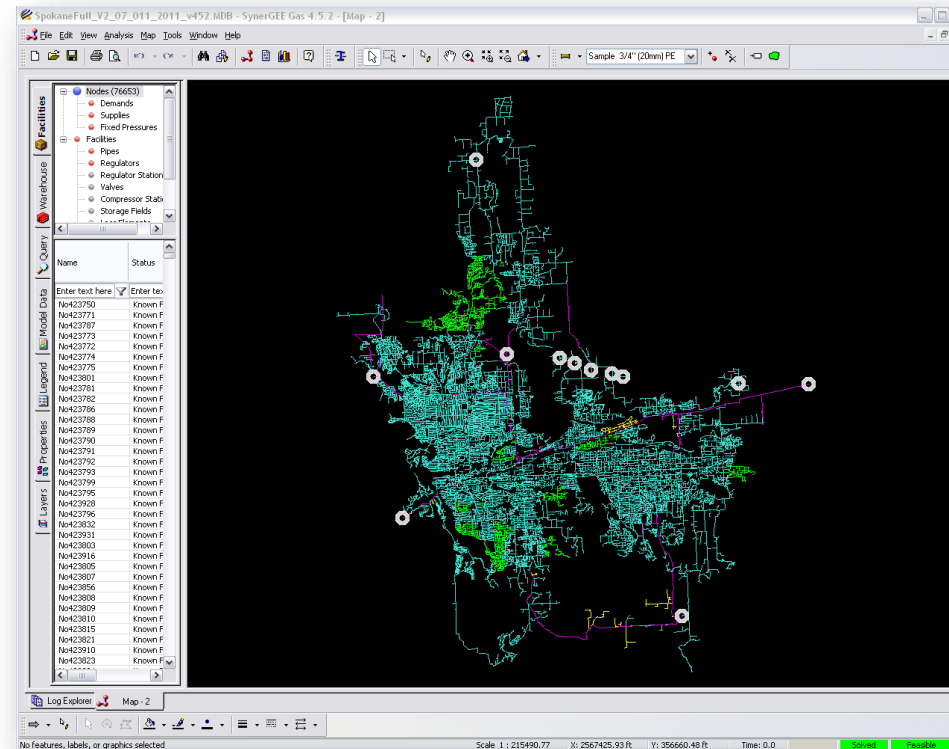

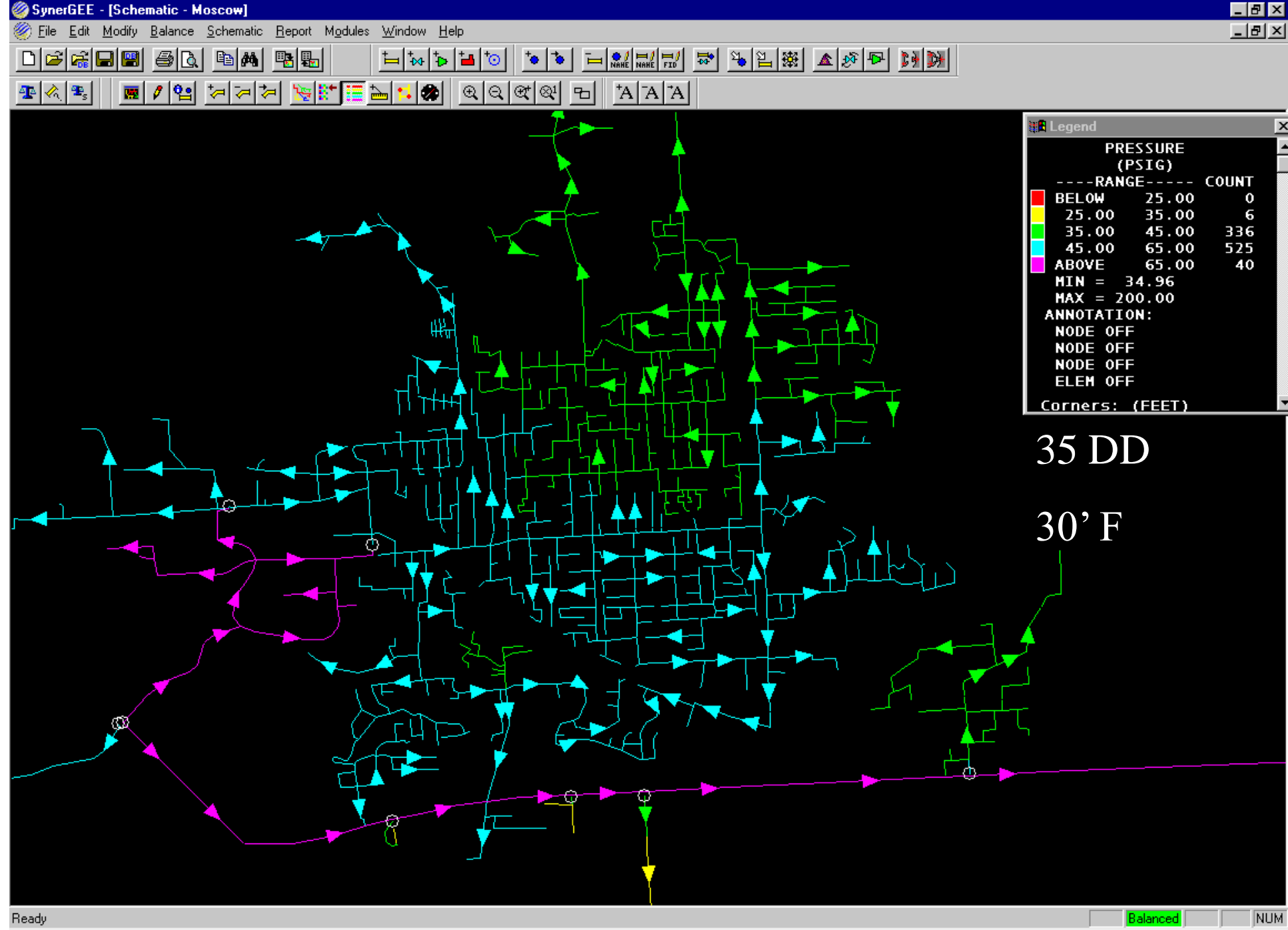

35 DD

30' F



Preparing a Load Study

- Estimating Customer Usage
- Creating a Pipeline Network
- Join Customer Loads to Pipes
- Convert to Load Study



Estimating Customer Usage

- Gathering Data
 - Days of service
 - Degree Days
 - Usage
 - Name, Address, Revenue Class, Rate Schedule...



Estimating Customer Usage cont.

- Degree Days
 - Heating (HDD)
 - Cooling (CDD)
- Temperature - Usage Relationship
 - Load vs. HDD's
 - Base Load (constant)
 - Heat Load (variable)
 - High correlation with residential

Avg. Daily Temperature ('Fahrenheit)	Heating Degree Days (HDD)	Cooling Degree Days (CDD)
85		20
80		15
75		10
70		5
65	0	0
60	5	
55	10	
50	15	
45	20	
40	25	
35	30	
30	35	
25	40	
20	45	
15	50	
10	55	
5	60	
4	61	
0	65	
-5	70	
-10	75	
-15	80	

Load vs. Temperature

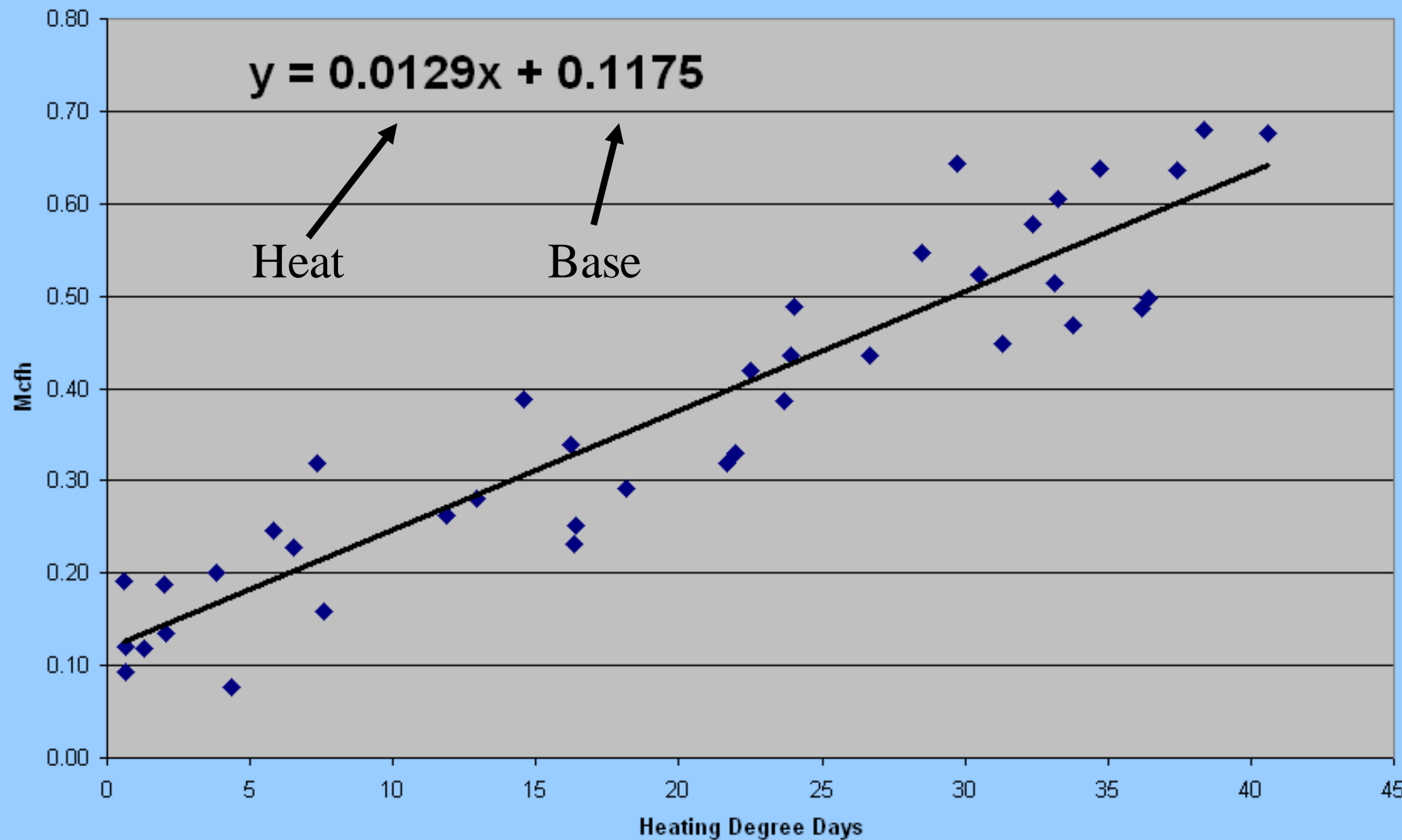

Creating a Pipeline Model

- Elements
 - Pipes, regulators, valves
 - Attributes: Length, internal diameter, roughness
- Nodes
 - Sources, usage points, pipe ends
 - Attributes: Flow, pressure

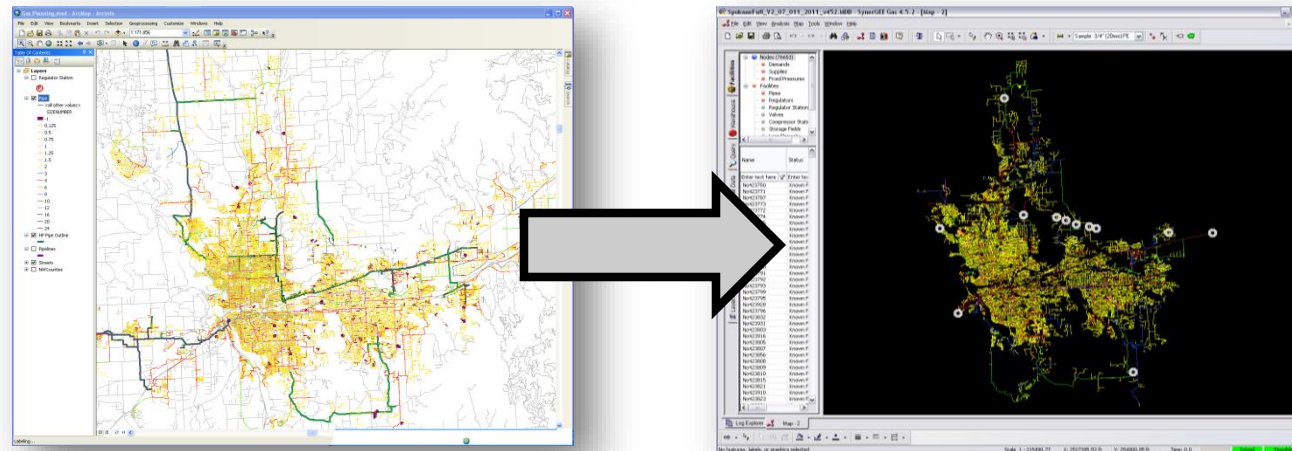

TERRENCE
 File Job Edit View Theme Graphics CAD Window Help
 [Icons: Undo, Redo, Copy, Paste, Print, Save, Open, Close, Home, Search, etc.]
 Scale 1: 26,170 2,526,466.09
 532,193.61

Attributes of Gas Pipes

Length	Gas	Gas_id	Equip_type	Equip_sub	Equipment	Cased_inc	Lock_id	Phase_id	Object_id	Ver_id	Ver_end	Did	Diameter	Year_inst	Joint_use	U
608.82431	4	1	GLS	MPLN	650089771	N	0	0	0	0	0	0	4.00	1999	JT/N	
679.06094	5	1	GLS	MPLN	650089772	N	0	0	0	0	0	0	2.00	1999	JT/N	
1463.75313	6	1	GLS	MSLN	650089774	N	0	0	0	0	0	0	2.00	1999	JT/N	
193.35819	6	1	GLS	MSLN	650089775	N	0	0	0	0	0	0	2.00	1999	JT/N	
435.19989	9	2	GLS	MPLN	650089776	N	0	0	0	0	0	0	2.00	1999	JT/N	
1090.20677	10	1	GLS	MPLN	650089781	N	0	0	0	0	0	0	4.00	1999	JT/N	
522.75341	11	2	GLS	MPLN	650089782	N	0	0	0	0	0	0	2.00	1999	JT/N	
1255.57481	12	2	GLS	MPLN	650089783	N	0	0	0	0	0	0	4.00	1999	JT/N	
822.95617	13	3	GLS	MPLN	650089784	N	0	0	0	0	0	0	4.00	1999	JT/N	
845.53503	14	2	GLS	MSLN	650089785	N	0	0	0	0	0	0	2.00	1999	JT/N	
269.16499	15	3	GLS	MSLN	650089786	N	0	0	0	0	0	0	2.00	1999	JT/N	

OTHER / MISC: Moscow

- Gas Devices
- Gas Pipes
- Diameter annotation
- Dimension annotation
- Exst. Devices
- Exst. Pipes
- Exst. Anno
- Exst. Dimension Anno
- Moscow Streets
- Whitman Co. Streets
- Railroads (Latah Co.)
- Railroads (Whitman Co.)
- Hydro (Latah Co.)
- Hydro (Whitman Co.)



TERRENCE
 File Job Edit View Theme Graphics CAD Window Help
 Scale 1: 26,170 2,512,479.69 533,887.53

Attributes of Moscgeood_cust_3-29-02.shp

Matched_id	Customer_n	House_num	Street_nme	Rural_ory	G	Geocd_q	Aug_usage	Aug_days_o	Aug_degree	Aug_dte
False	U OF I			U OF I LIFE SCIENCE BLDG	G		586.000000	31.000000	32.000000	2001-08-27 01
False	U OF I			MINES 7TH ST & LINE ST	G		0.000000	31.000000	32.000000	2001-08-27 01
False	U OF I			ART & ARCH BLDG	G		210.000000	31.000000	32.000000	2001-08-27 01
False	UNIVERSITY OF IDAHO			ANIMAL DISEASE RESEARCH	G		4558.000000	31.000000	32.000000	2001-08-27 01
False	U OF I			AQUACULTURE INSTITUTE	G		92.000000	31.000000	32.000000	2001-08-27 01
False	U OF I			POULTRY	G		0.000000	31.000000	32.000000	2001-08-27 01
False	U OF I			KIBBIE STADIUM	G		688.000000	31.000000	32.000000	2001-08-27 01
False	B P O E NO 249	3080	HIGHWAY 8		G		6.000000	28.000000	17.000000	2001-08-20 01
False	B P O E NO 249	3080	HIGHWAY 8		G		71.000000	28.000000	17.000000	2001-08-20 01
False	U OF I			MACHINE SHED	G		0.000000	29.000000	17.000000	2001-08-20 01
False	JAMESON COMMERCIAL PR			PEPPERMILL/DR BOWEN	G		9.000000	23.000000	32.000000	2001-08-07 01

OTHER / MISC: Moscow

- Moscgeood_cust_3-29-02
- Gas Devices
- Gas Pipes
- Diameter annotation
- Dimension annotation
- Exst. Devices
- Exst. Pipes
- Exst. Anno
- Exst. Dimension Anno
- Moscow Streets
- Whitman Co. Streets
- Railroads (Latah Co.)
- Railroads (Whitman Co.)
- Hydro (Latah Co.)
- Hydro (Whitman Co.)



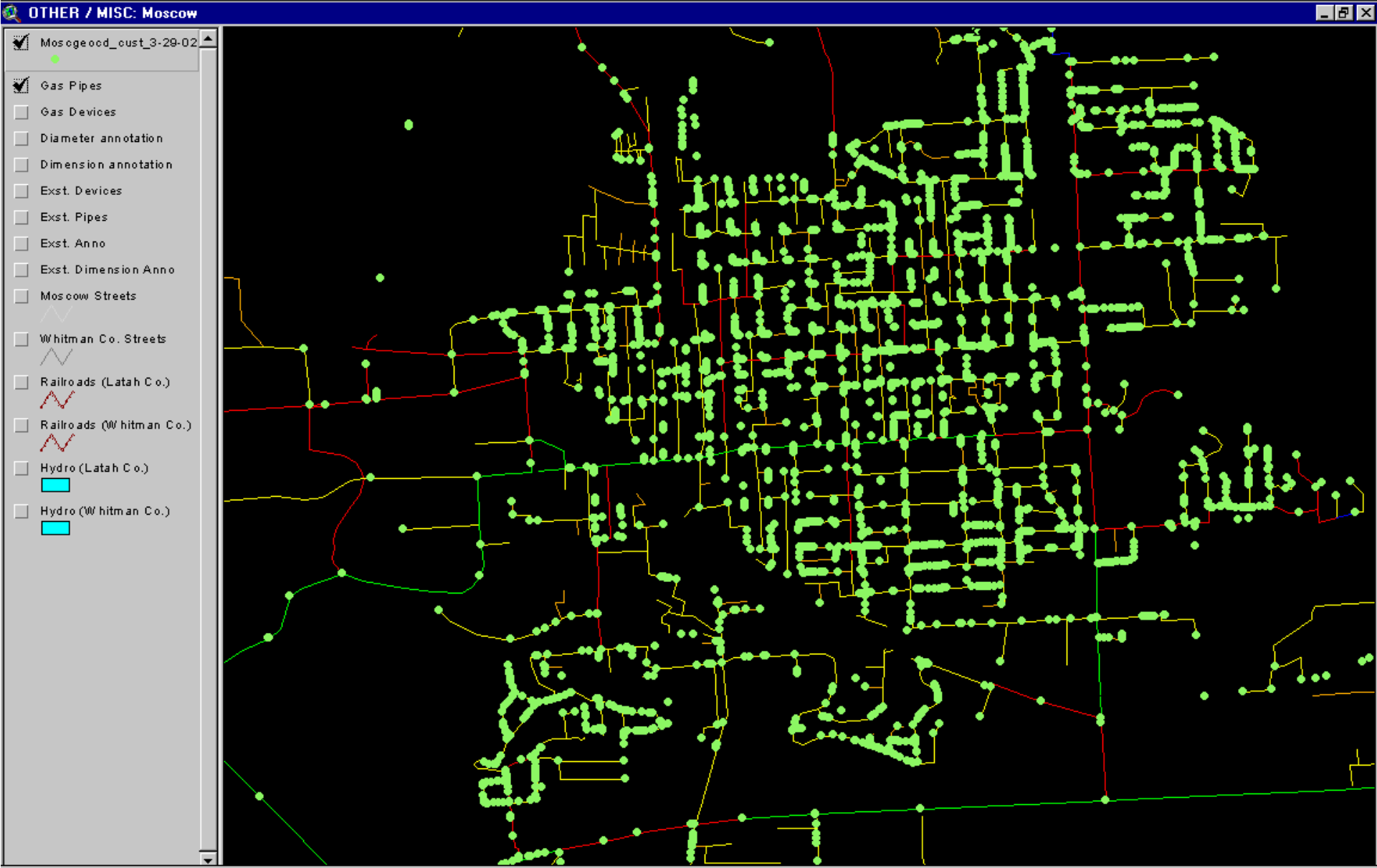

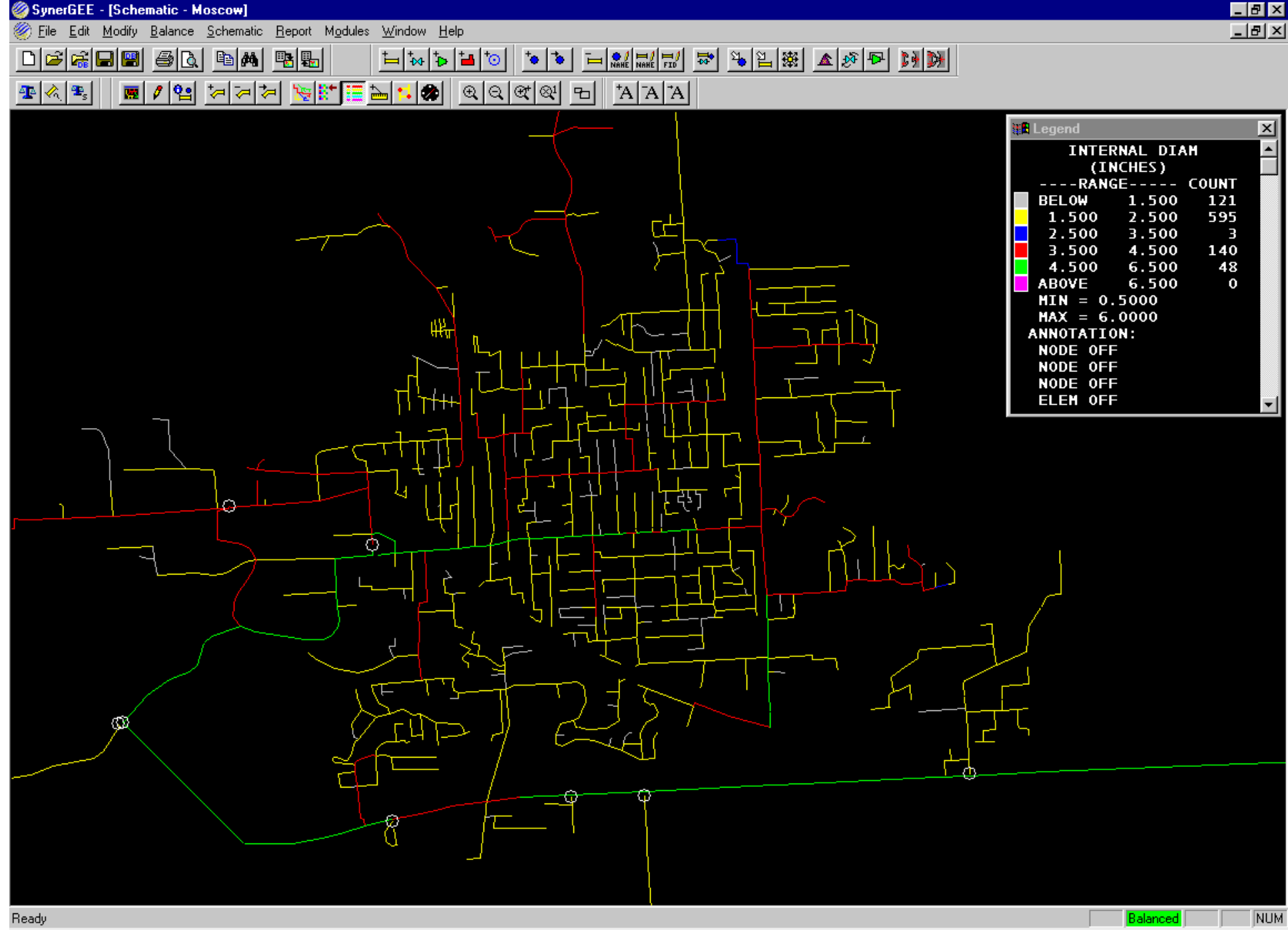

Balancing Model

- Simulate system for any temperature
 - HDD's
- Solve for pressure at all nodes



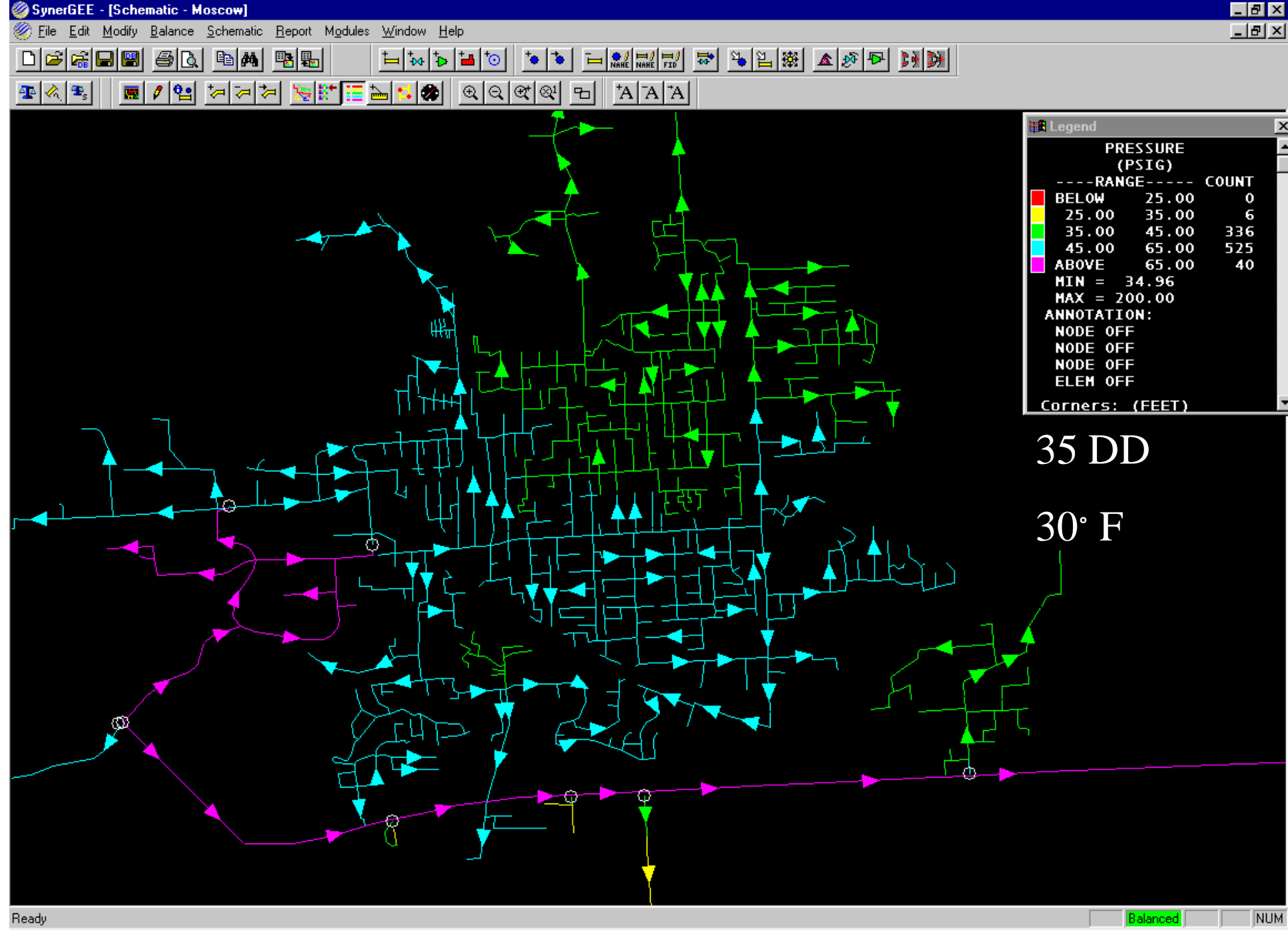

Validating Model



Validating Model cont.

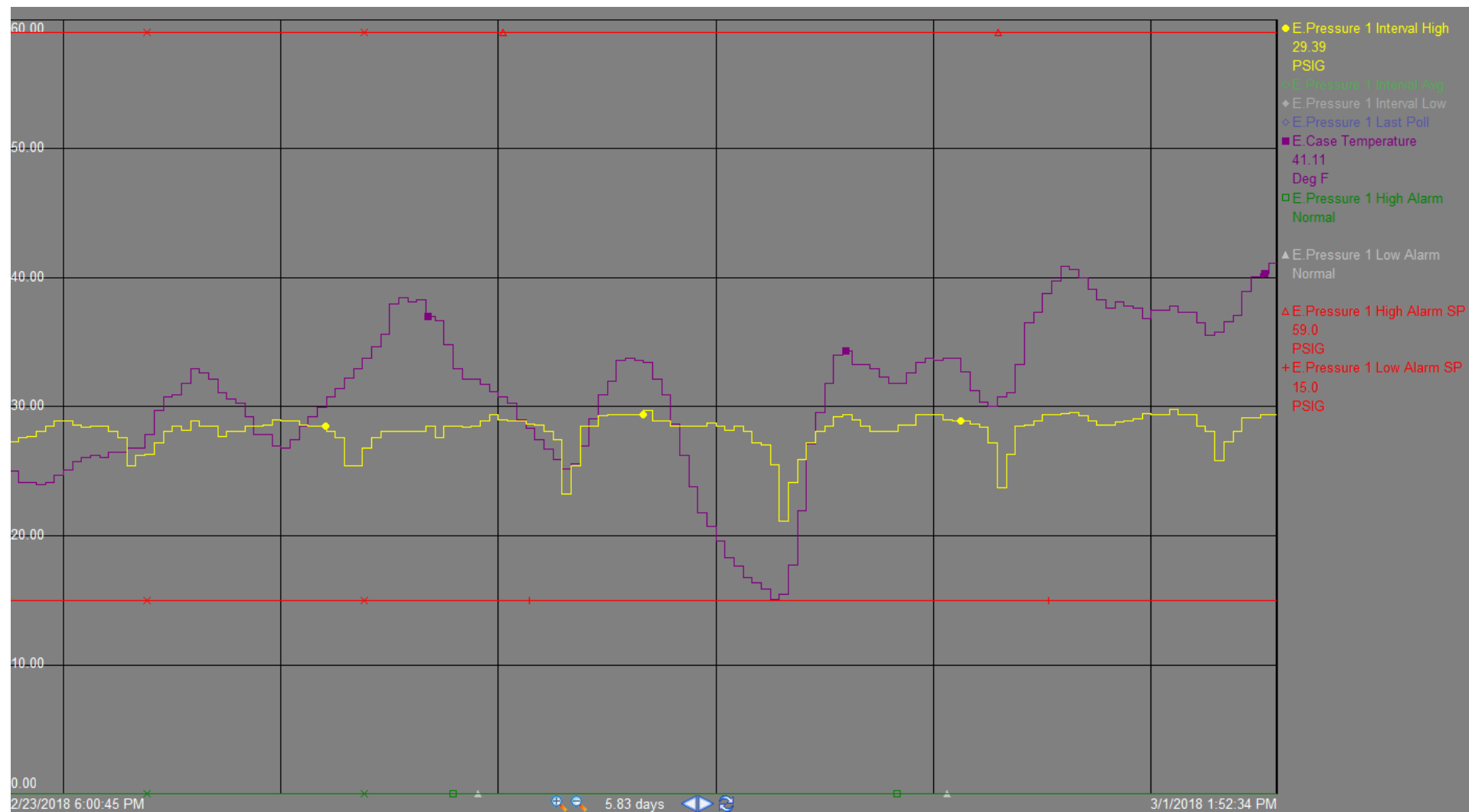

Validating Model cont.

- Simulate recorded condition
- Electronic Pressure Recorders
 - Do calculated results match field data?
- Gate Station Telemetry
 - Do calculated results match source data?
- Possible Errors
 - Missing pipe
 - Source pressure changed
 - Industrial loads

Planning Criteria

- Reliability during design HDD
 - Spokane **77 HDD** (*avg. daily temp. -12' F*)
 - Medford **54 HDD** (*avg. daily temp. 11' F*)
 - Klamath Falls **74 HDD** (*avg. daily temp. -9' F*)
 - La Grande **76 HDD** (*avg. daily temp. -11' F*)
 - Roseburg **51 HDD** (*avg. daily temp. 14' F*)
- Maintain minimum of 15 psig in system at all times
 - 5 psig in lower MAOP areas

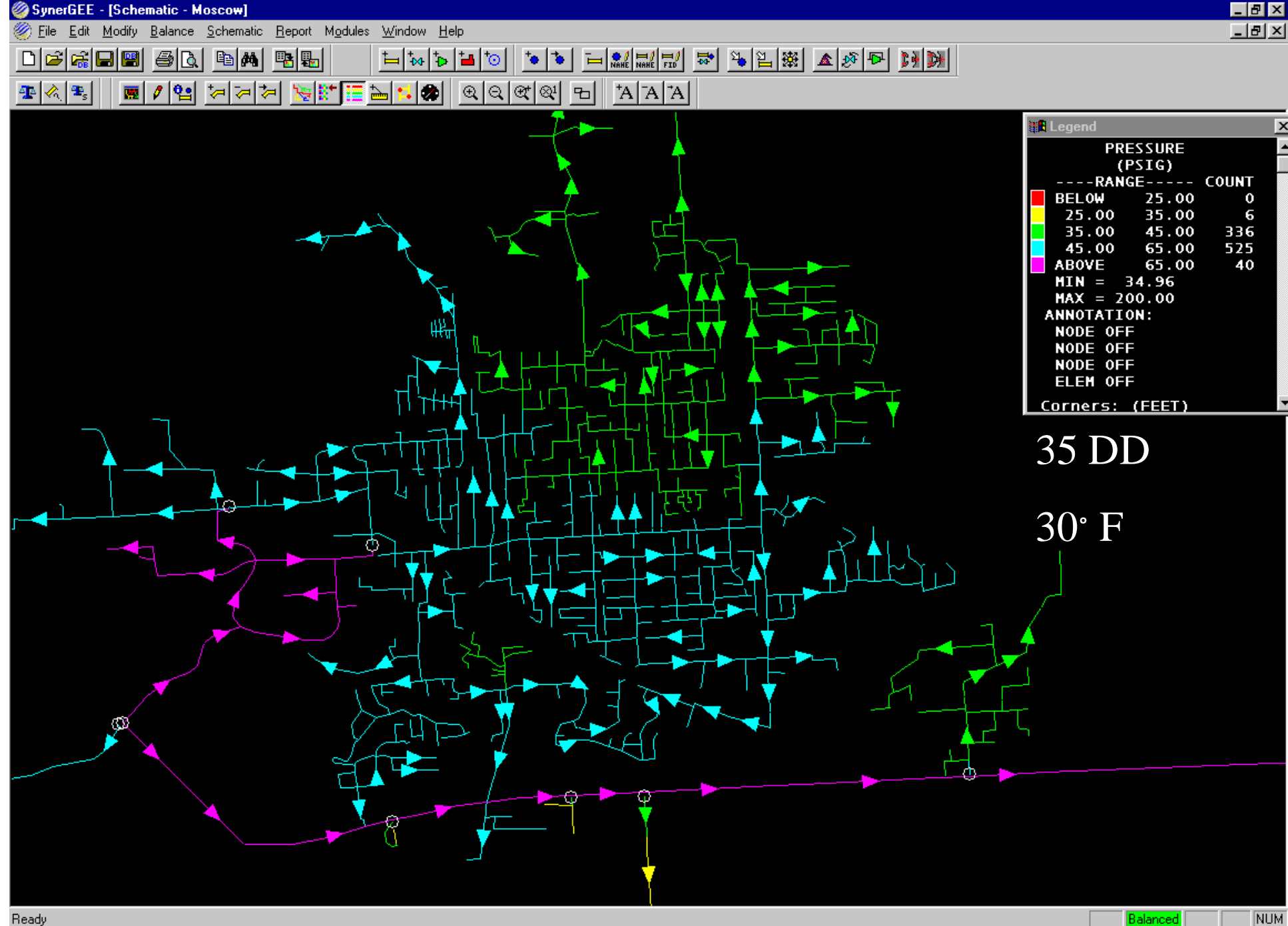

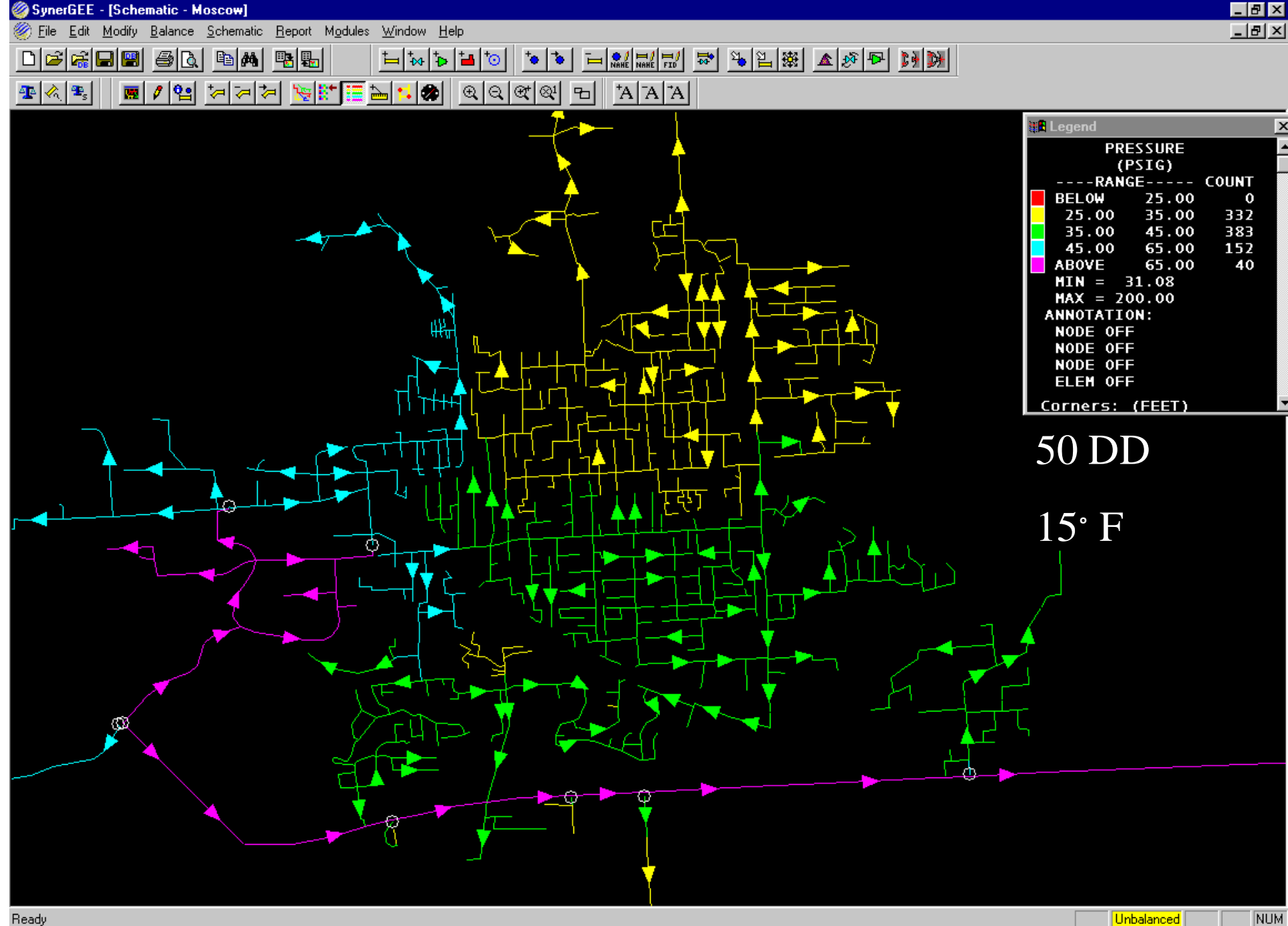

50 DD

15° F



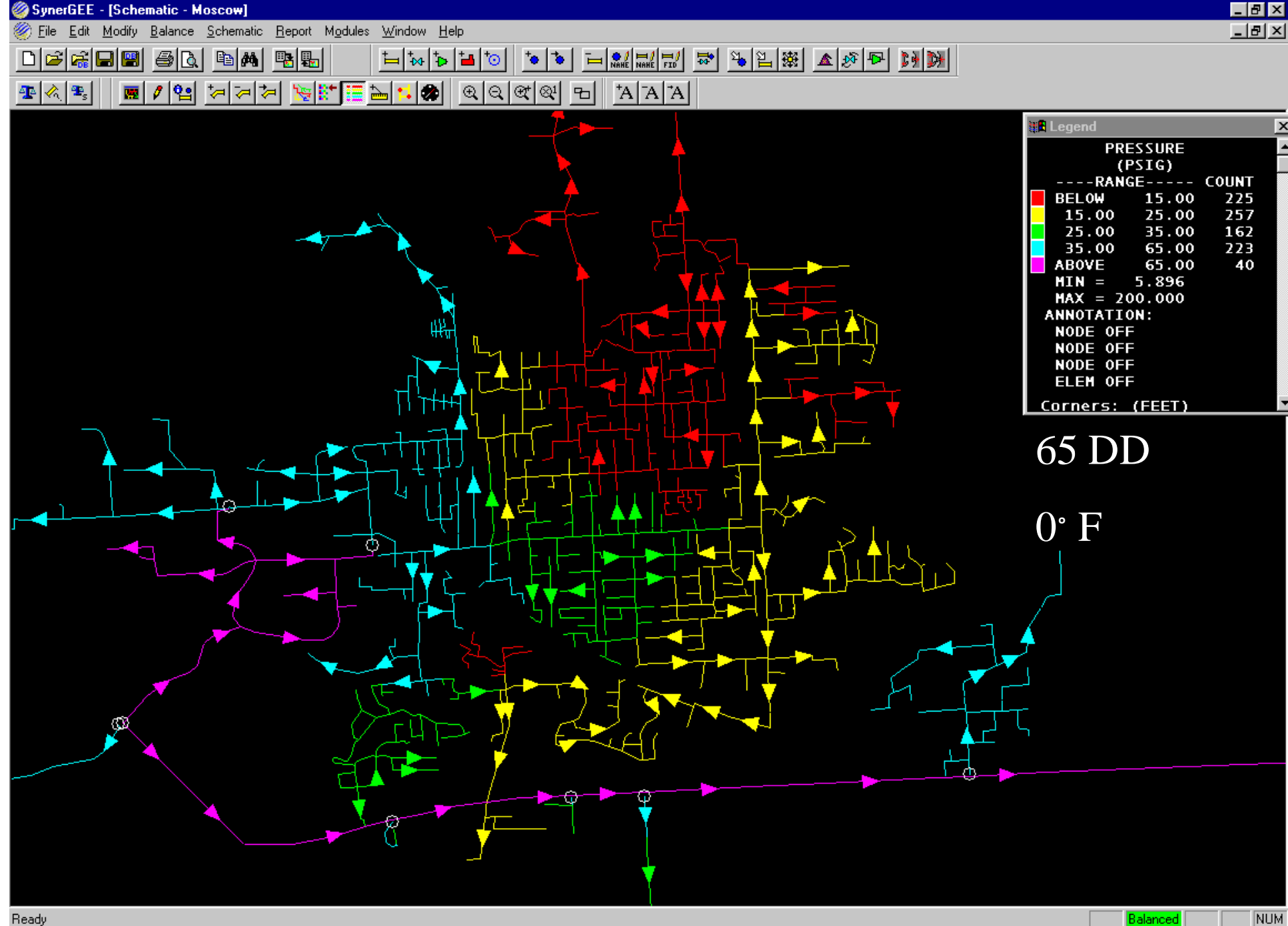

Interpreting Results

- Identify Low Pressure Areas
 - Number of feeds
 - Proximity to source
- Looking for Most Economical Solution
 - Length (minimize)
 - Construction obstacles (minimize)
 - Customer growth (maximize)



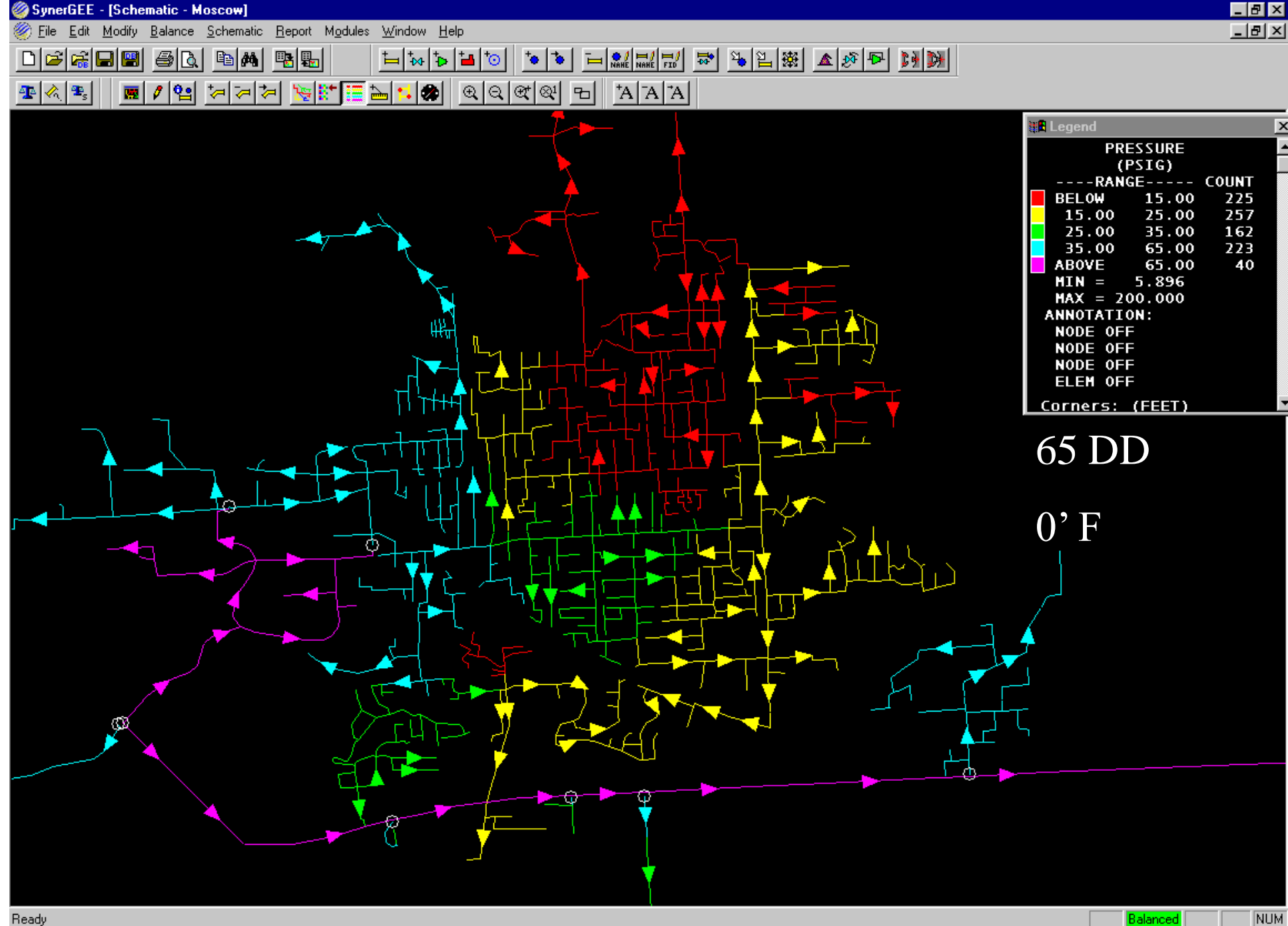

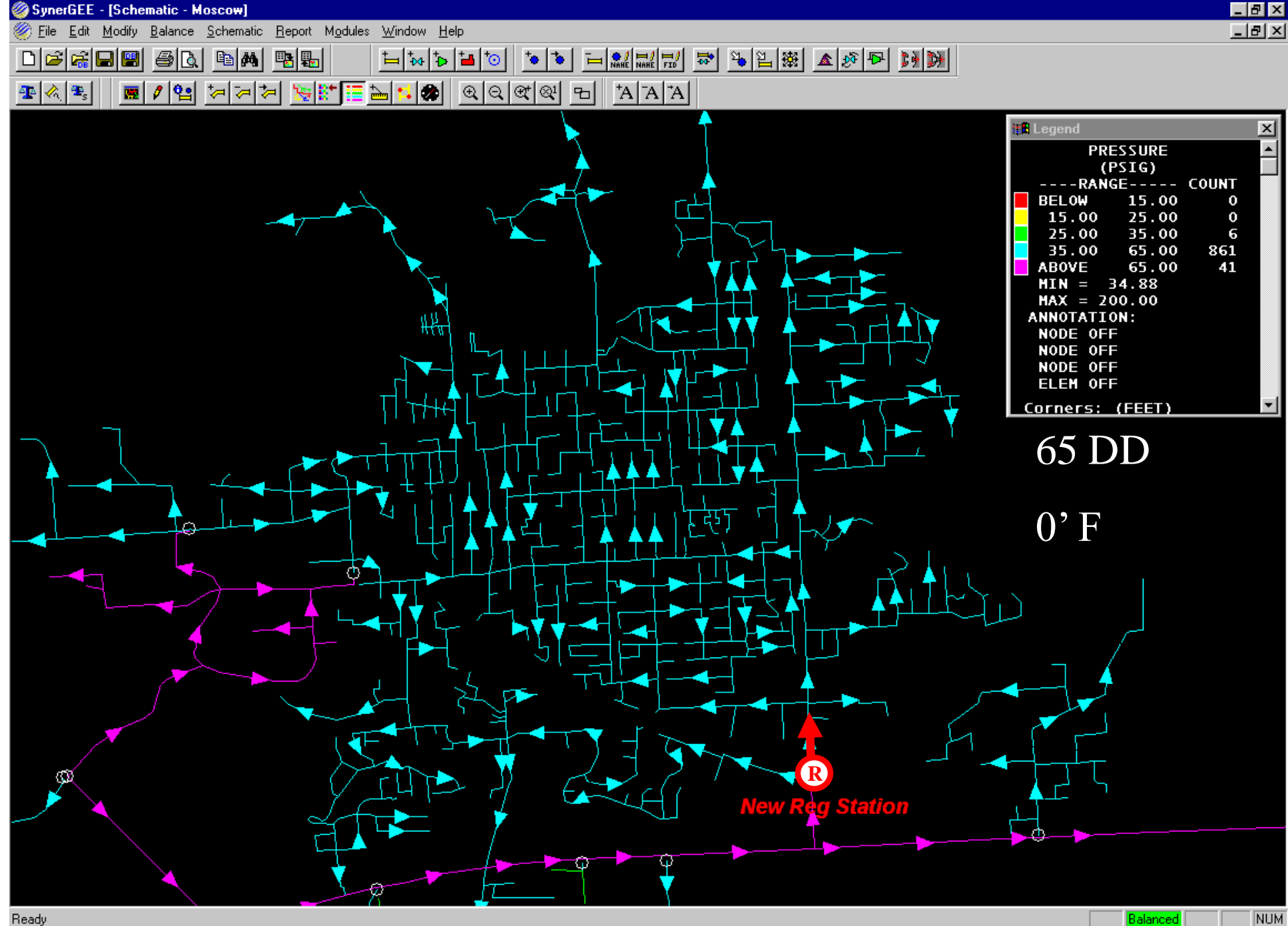

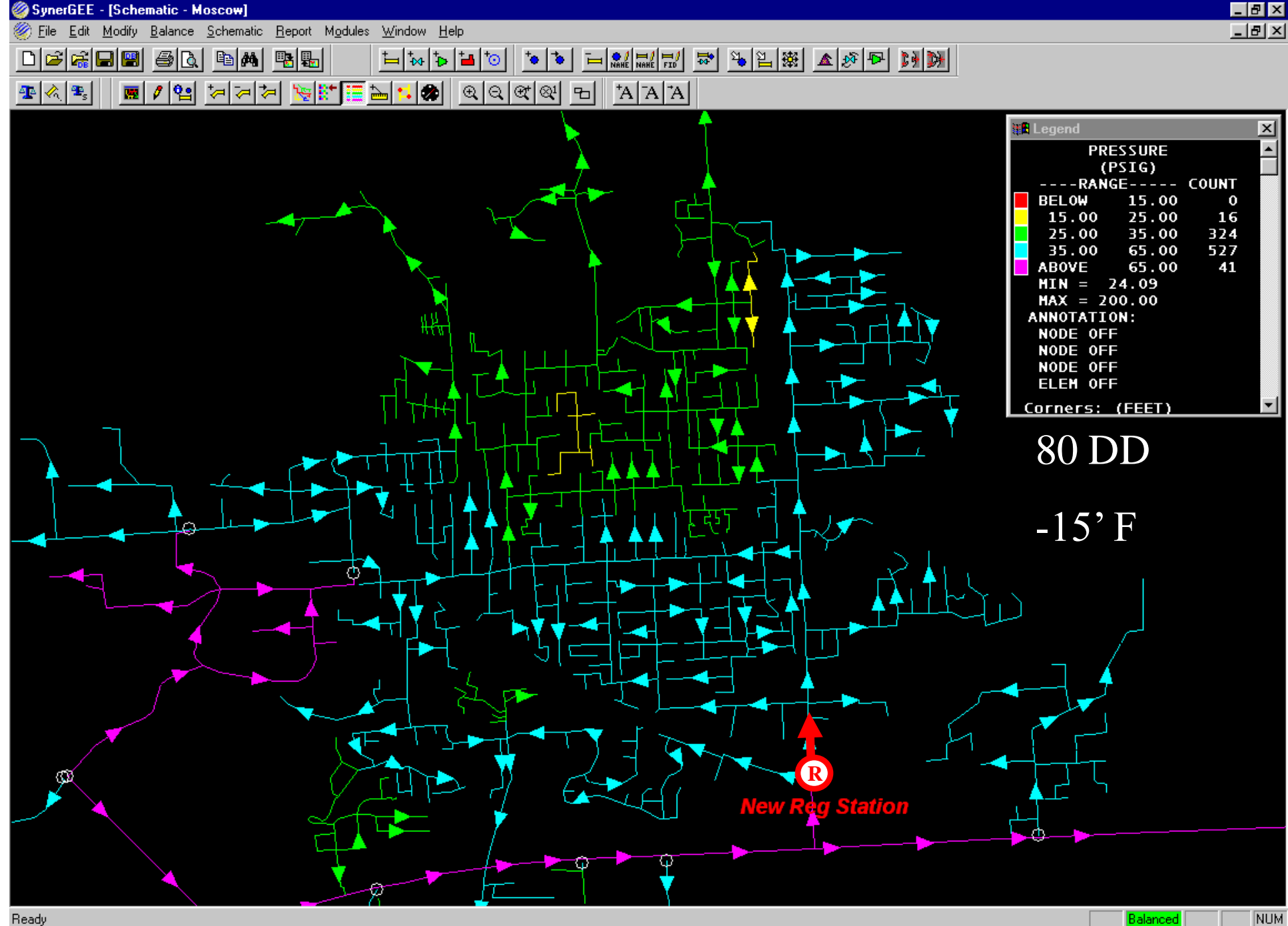

Long-term Planning Objectives

- Future Growth/Expansion
- Design Day Conditions
- Facilitate Customer Installation Targets



Monitoring Our System

- Electronic Pressure Recorders
 - Daily Feedback
 - Real time if necessary
- Validates our Load Studies



Real-time Pressure & Flow Monitoring

PI ProcessBook - [WA GAS DASHBOARD.pdi]

File Edit View Insert Tools Draw Arrange Window Help

3/12/2013 4/16/2013 100%

Y:\PI\AVISTA PI GAS SUMMARY\WA GAS DASHBOARD.pdi

SPOKANE VICINITY

American Linen	Eastern VVA Univ	Inland NV Dairy	Mutual Materials C	Sacred Heart	State Corrections
B.F. Goodrich	Fairchild AFB	Kaiser Mead	NECT	Shamrock Pavi	Travis Foundry
Baker Commodit	Franz Bakery	Kaiser Trentwood	9-Mile CG	SCC	Triumph Group
Boulder Park G	Gonzaga U	Lakeland Village	9-Mile Reg 56	SFCC	VA Hospital
CDA Sunset Reg	Hayford Rd. Reg	Liberty Lake Reg	Perry Wildrose 7	Spokane Court	Valley Medical
Central Pre-Mix	Holy Family Hospi	Lyons Rd Reg 17	Progress Rd Reg	Spokane Industrie	vWhitworth College
Creach	Huntwood	Madison & Thorpe	Pulpwood	Spokane Rock	Waste 2 Energy
Davenport Reg	Inland Asp Valley	Mead CG	Purina Mills	Spo West CG	Waste Mgt CNG
Deaconess Hospi	Inland Asp Perry	Medical Lake C	Quarry Tile	Starr Rd Reg 47	W. St. Asphalt
Eastern St. Hospi		Mica CG	Reg 700	Starr Road CG	W St Asp Velox

COLVILLE

B. C. Arden
Colville Dist. Pres
Chewelah Cntry C
Chewelah Reg
BC Ply Kettle
Kettle Falls Prs
Kettle Falls Gen
Kettle CG-Indian T
Lane Mt Silica

Switchboard ID OR

SCADA Scanning Status ● Scanning

PULLMAN

Pullman Reg 352
Pullman CG
WSU
WSU GWSP

CLARKSTON

Asotin Pressure
Clarkston Reg 43'
Clarkston Svc Ctr
Lower Critchfield
Upper Critchfield

OTHER

Connell CG	Ritzville CG
Goldendale CG	Stevenson CG
Lamb-Weston Boi	Warden CG
Lamb-Weston Fir	WA Potato Co
Lind Pressure	

Legend

Out of Service	Lost Connection
Not Yet In Service	Blinking: In Alarm

General Information

Read Rates Missing Data

Read Rate Trends

ERX #007

West Medford 6 psig
System

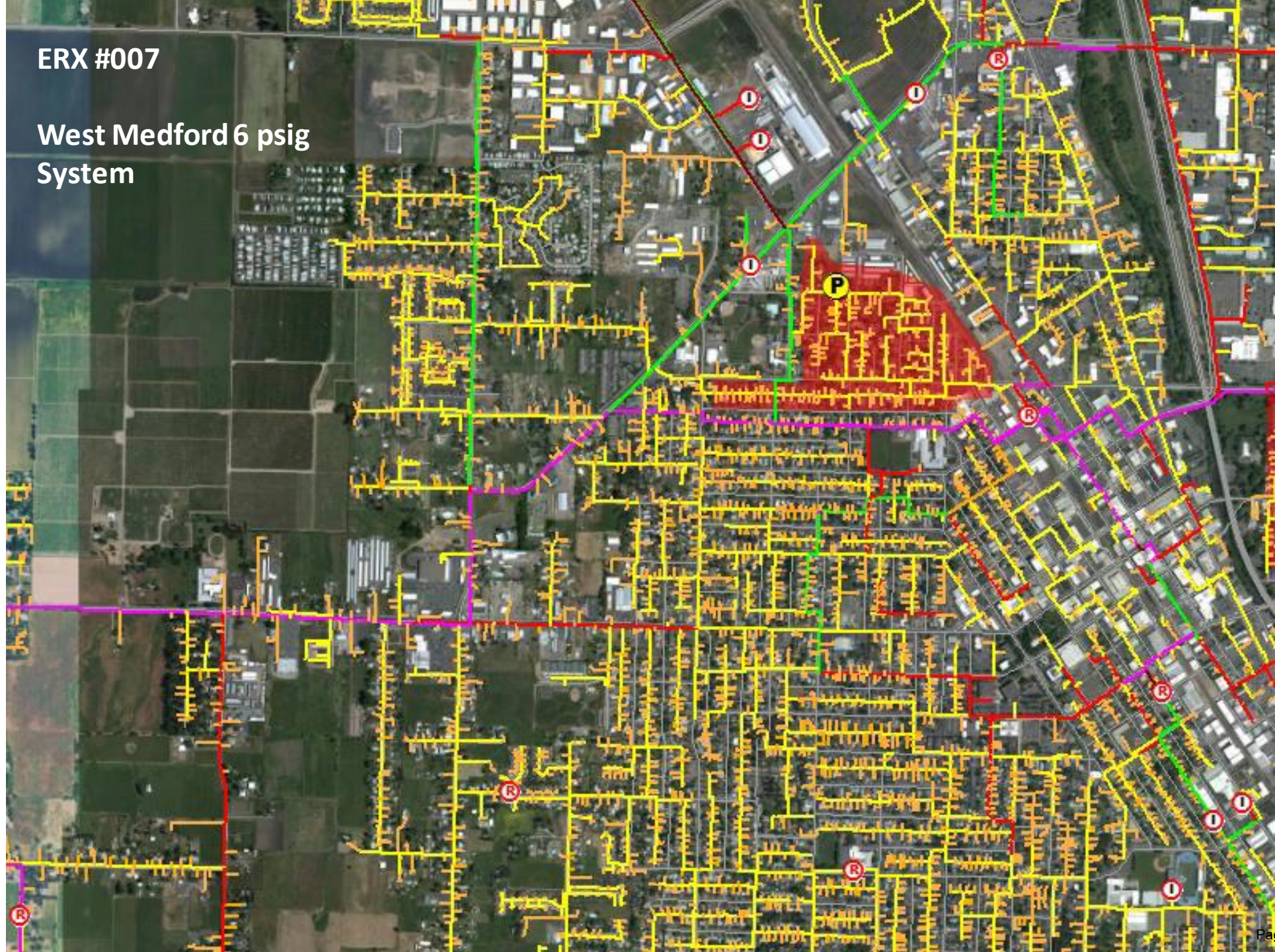

ERX #007: West Medford 6 psig System, OR

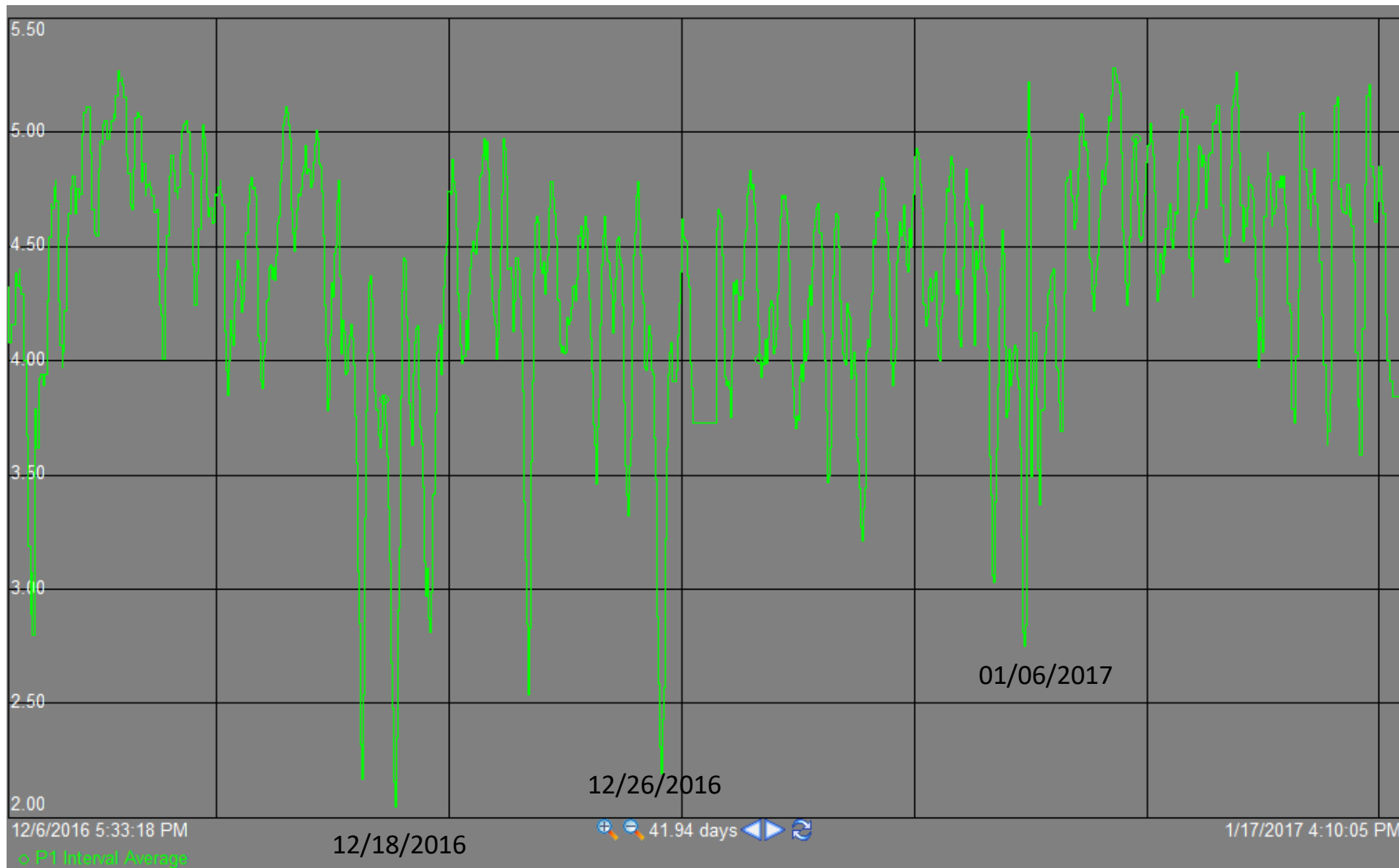

2019-2020 Winter



Gas Load And Weather Forecast Report

Page: 1
 Date: 01/08/20 01:00 PM
 Database: NUCPRD
 gs_fore_temp

Date: 01/08/2020

Area: LAGRANDE

Date:	Hi	Lo	HDD	Load
SUN 01/05/20	39	29	30	3,827
MON 01/06/20	39	32	29	3,984
TUE 01/07/20	44	37	24	3,474
WED 01/08/20	41	30	30	3,636
THU 01/09/20	35	23	35	4,284
FRI 01/10/20	35	27	33	4,220
SAT 01/11/20	39	31	30	3,812
SUN 01/12/20	39	31	30	3,788
MON 01/13/20	33	26	34	4,241
TUE 01/14/20	27	15	43	5,177

Average: 4,044

Area: SPOKANE

Date:	Hi	Lo	HDD	Load
SUN 01/05/20	40	31	31	119,295
MON 01/06/20	44	33	24	108,349
TUE 01/07/20	45	36	24	99,618
WED 01/08/20	40	27	31	113,614
THU 01/09/20	33	26	36	130,326
FRI 01/10/20	34	27	33	127,052
SAT 01/11/20	35	31	32	120,468
SUN 01/12/20	32	23	38	132,989
MON 01/13/20	24	14	46	163,049
TUE 01/14/20	17	1	55	190,891

Average: 130,565

Area: KLAMATH FALLS

Date:	Hi	Lo	HDD	Load
SUN 01/05/20	38	28	33	8,302
MON 01/06/20	45	20	35	7,822
TUE 01/07/20	47	21	29	7,345
WED 01/08/20	38	28	32	7,872
THU 01/09/20	36	21	37	8,027
FRI 01/10/20	39	24	31	7,783
SAT 01/11/20	38	28	32	7,650
SUN 01/12/20	38	30	31	7,617
MON 01/13/20	38	24	34	7,923
TUE 01/14/20	30	20	40	8,786

Average: 7,913

Area: LEWISTON

Date:	Hi	Lo	HDD	Load
SUN 01/05/20	46	34	24	15,796
MON 01/06/20	49	41	18	14,631
TUE 01/07/20	52	38	20	12,168
WED 01/08/20	47	36	24	14,115
THU 01/09/20	39	29	30	17,991
FRI 01/10/20	40	32	28	17,517
SAT 01/11/20	44	37	25	15,788
SUN 01/12/20	42	36	26	16,308
MON 01/13/20	38	31	30	18,342
TUE 01/14/20	31	18	40	22,165

Average: 16,482

Area: MEDFORD

Date:	Hi	Lo	HDD	Load
SUN 01/05/20	47	34	25	27,581
MON 01/06/20	49	30	27	30,760
TUE 01/07/20	40	31	28	32,807
WED 01/08/20	45	38	25	30,458
THU 01/09/20	43	32	28	31,174
FRI 01/10/20	43	33	26	30,409
SAT 01/11/20	42	37	25	27,942
SUN 01/12/20	43	38	26	27,696
MON 01/13/20	40	33	28	31,906
TUE 01/14/20	37	30	31	34,882

Average: 30,562

Area: OTHER

Date:	Hi	Lo	HDD	Load
SUN 01/05/20	0	0	0	210
MON 01/06/20	0	0	0	207
TUE 01/07/20	0	0	0	207

Average: 208

Area: ROSEBURG

Date:	Hi	Lo	HDD	Load
SUN 01/05/20	49	41	20	7,334
MON 01/06/20	53	41	17	7,574
TUE 01/07/20	55	40	18	6,956
WED 01/08/20	48	41	21	7,363
THU 01/09/20	47	35	25	7,888
FRI 01/10/20	48	36	21	7,649
SAT 01/11/20	49	41	20	6,840
SUN 01/12/20	48	42	21	7,201
MON 01/13/20	46	37	23	7,942
TUE 01/14/20	46	35	26	8,553

Average: 7,530

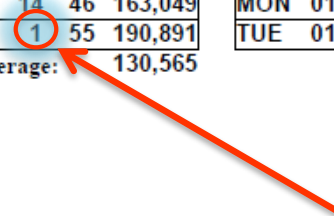

2013-2014 Winter

Area: LaGrande					Area: Klamath Falls					Area: Medford					Area: Roseburg				
Date	Hi	Lo	HDD	Load	Date	Hi	Lo	HDD	Load	Date	Hi	Lo	HDD	Load	Date	Hi	Lo	HDD	Load
SAT 12/7/2013	18	-4	58	6,615	SAT 12/7/2013	21	-16	63	11,170	SAT 12/7/2013	32	11	44	40,462	SAT 12/7/2013	27	18	43	11,843
SUN 12/8/2013	9	-9	65	6,695	SUN 12/8/2013	6	-20	72	12,002	SUN 12/8/2013	25	2	52	47,855	SUN 12/8/2013	26	15	44	13,011
MON 12/9/2013	21	-4	56	5,389	MON 12/9/2013	14	-17	66	11,474	MON 12/9/2013	27	4	50	48,999	MON 12/9/2013	31	17	41	9,984
TUE 12/10/2013	29	16	42	4,897	TUE 12/10/2013	31	-6	52	9,299	TUE 12/10/2013	38	9	41	44,095	TUE 12/10/2013	34	19	38	10,867
WED 12/11/2013	30	15	42	4,689	WED 12/11/2013	36	7	43	8,799	WED 12/11/2013	42	17	35	35,943	WED 12/11/2013	40	28	31	9,197
THU 12/12/2013	35	20	37	4,131	THU 12/12/2013	39	9	41	8,191	THU 12/12/2013	42	20	34	35,273	THU 12/12/2013	40	30	30	8,730
FRI 12/13/2013	41	27	31	3,398	FRI 12/13/2013	42	17	35	7,206	FRI 12/13/2013	44	29	28	29,966	FRI 12/13/2013	42	33	27	8,112
SAT 12/14/2013	38	22	35	3,618	SAT 12/14/2013	45	15	35	6,887	SAT 12/14/2013	48	26	28	27,507	SAT 12/14/2013	43	30	28	7,686
SUN 12/15/2013	41	23	33	3,491	SUN 12/15/2013	47	16	33	6,681	SUN 12/15/2013	50	25	27	26,954	SUN 12/15/2013	45	32	26	7,418
MON 12/16/2013	40	22	34	3,642	MON 12/16/2013	47	16	33	6,812	MON 12/16/2013	49	27	27	27,580	MON 12/16/2013	44	34	26	7,682
Area: Spokane					Area: Lewiston														
Date	Hi	Lo	HDD	Load	Date	Hi	Lo	HDD	Load										
SAT 12/7/2013	15	0	57	195,583	SAT 12/7/2013	18	2	55	31,016										
SUN 12/8/2013	15	-2	58	183,544	SUN 12/8/2013	13	0	59	31,386										
MON 12/9/2013	20	9	51	166,628	MON 12/9/2013	26	8	48	25,901										
TUE 12/10/2013	25	12	46	156,433	TUE 12/10/2013	28	22	40	21,715										
WED 12/11/2013	29	15	43	145,441	WED 12/11/2013	31	17	41	22,022										
THU 12/12/2013	31	20	39	134,506	THU 12/12/2013	34	21	37	19,886										
FRI 12/13/2013	33	26	35	120,774	FRI 12/13/2013	38	29	31	17,448										
SAT 12/14/2013	35	27	34	114,257	SAT 12/14/2013	36	27	33	17,579										
SUN 12/15/2013	36	27	33	114,089	SUN 12/15/2013	38	27	32	17,570										
MON 12/16/2013	34	26	35	120,924	MON 12/16/2013	36	27	33	18,079										

What I do when “things” look bad?

- 1) Notify service area manager
- 2) Show where and at what temperature we think we'll have low pressure
- 3) Identify possible solutions like:
 - Curtailing interruptible customers
 - Ask schools & businesses to voluntarily lower thermostats
 - Bring out CNG trailers
- 4) Continue to monitor forecast to see if temperatures improve or get worse
- 5) Share plan with Gas Controllers
- 6) *Pray for warmer weather...*

Communicating Solutions

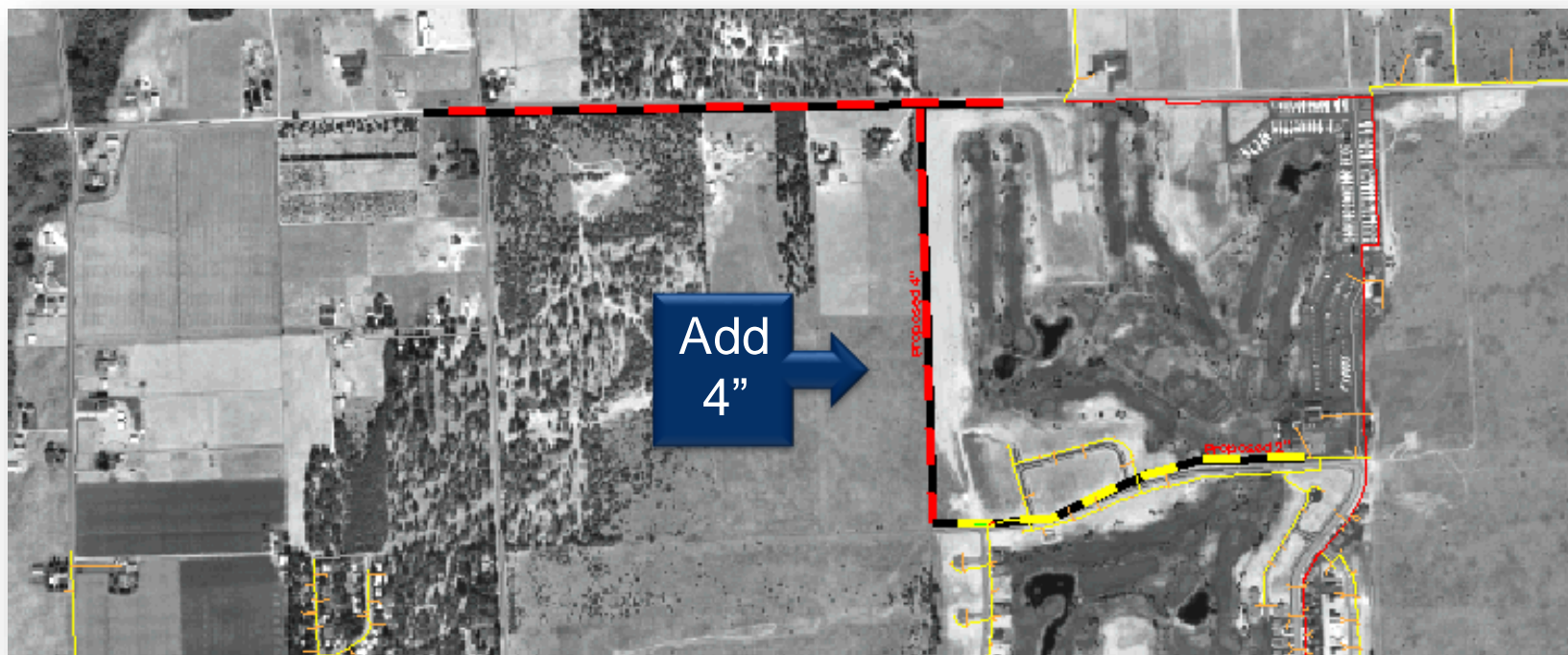

- Gas Planning Proposals
- SIZENUMBER
- 2"
- 4"
- 6"
- >6"

Gas Planning AOI

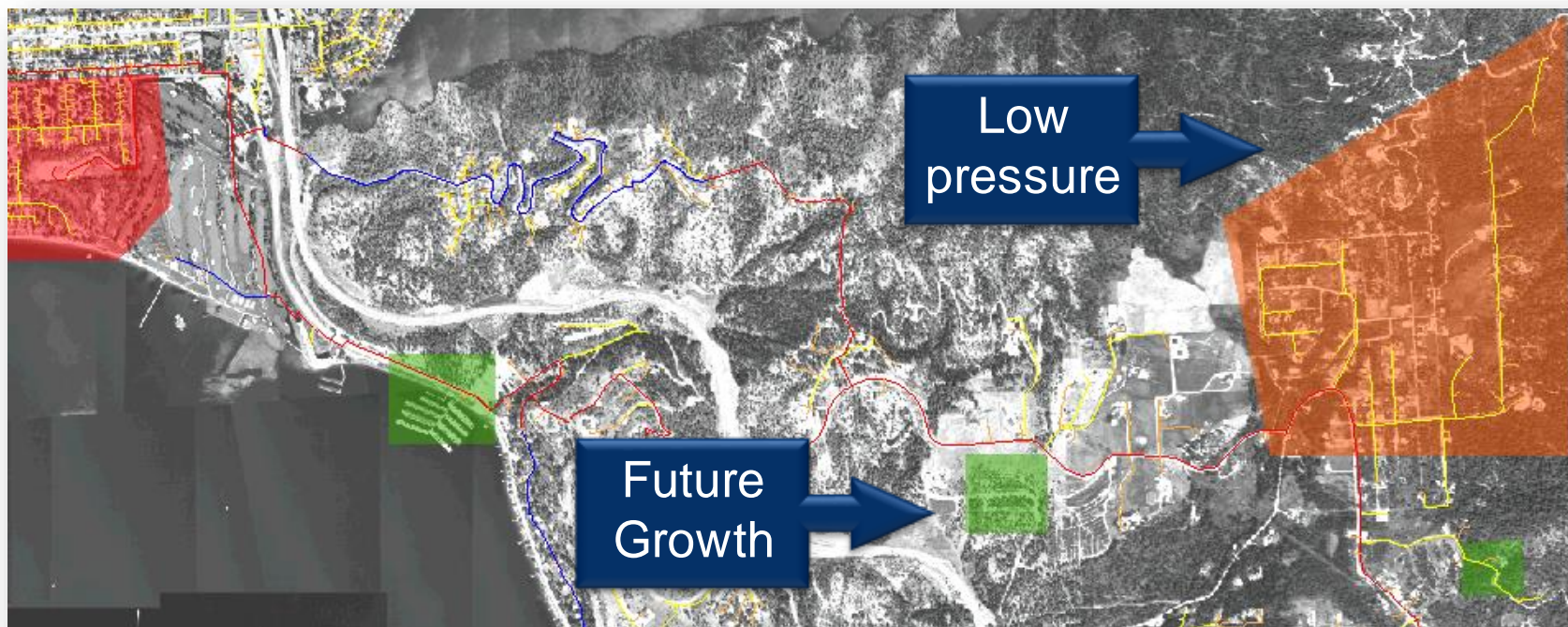

- Gas Planning AOI
- Area Type
- Critical Pressure
- Low Pressure
- Miscellaneous
- New Developments

Solutions: long-term reinforcements

State	Feet of pipe*	Estimated Cost \$*
Idaho	8,000	500,000
Oregon	22,000	1,600,000
Washington	70,000	4,900,000

*projects are subject to change and will be reviewed on a regular basis



Gate Station Capacity Review

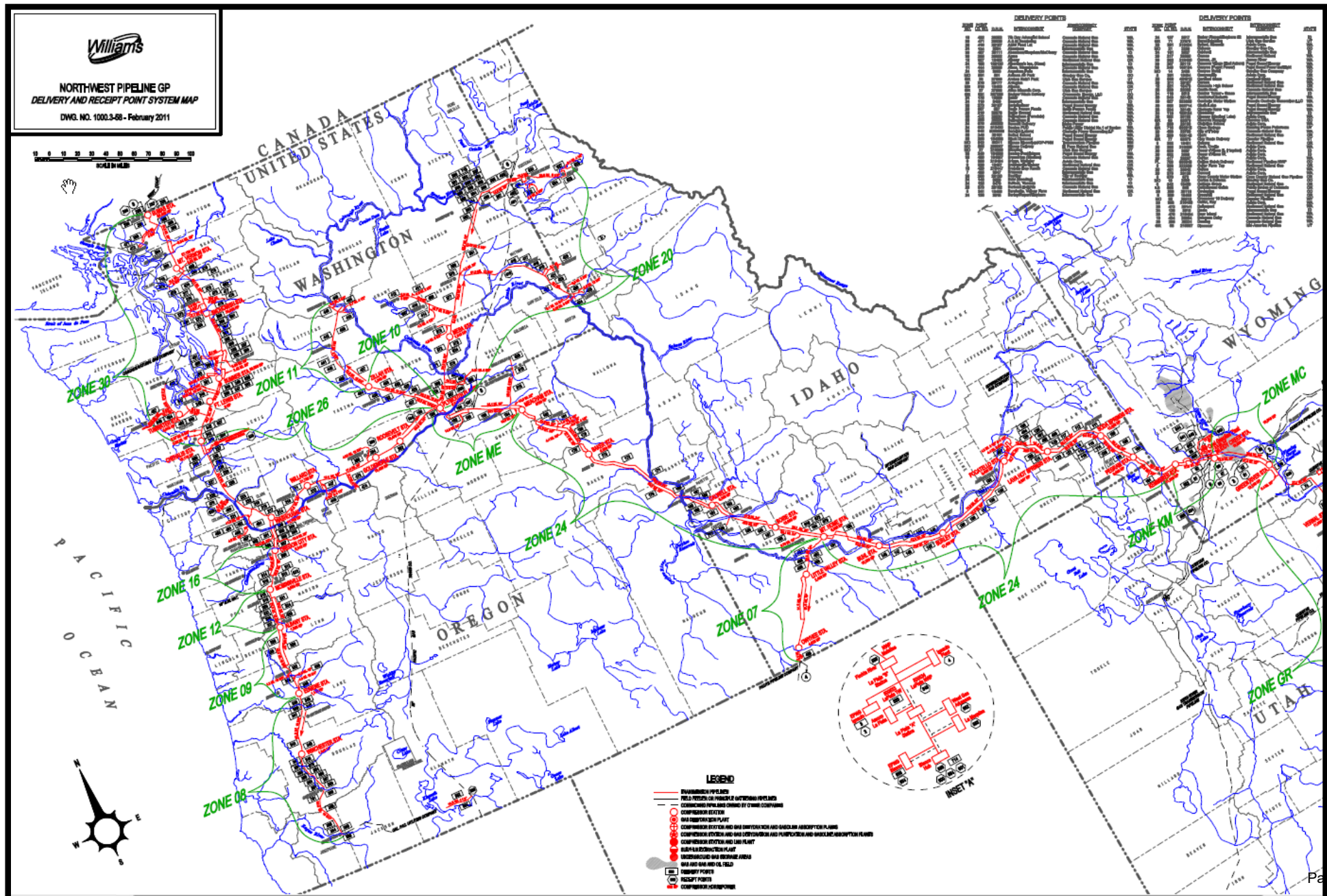

Gate Station Capacity Review (example)

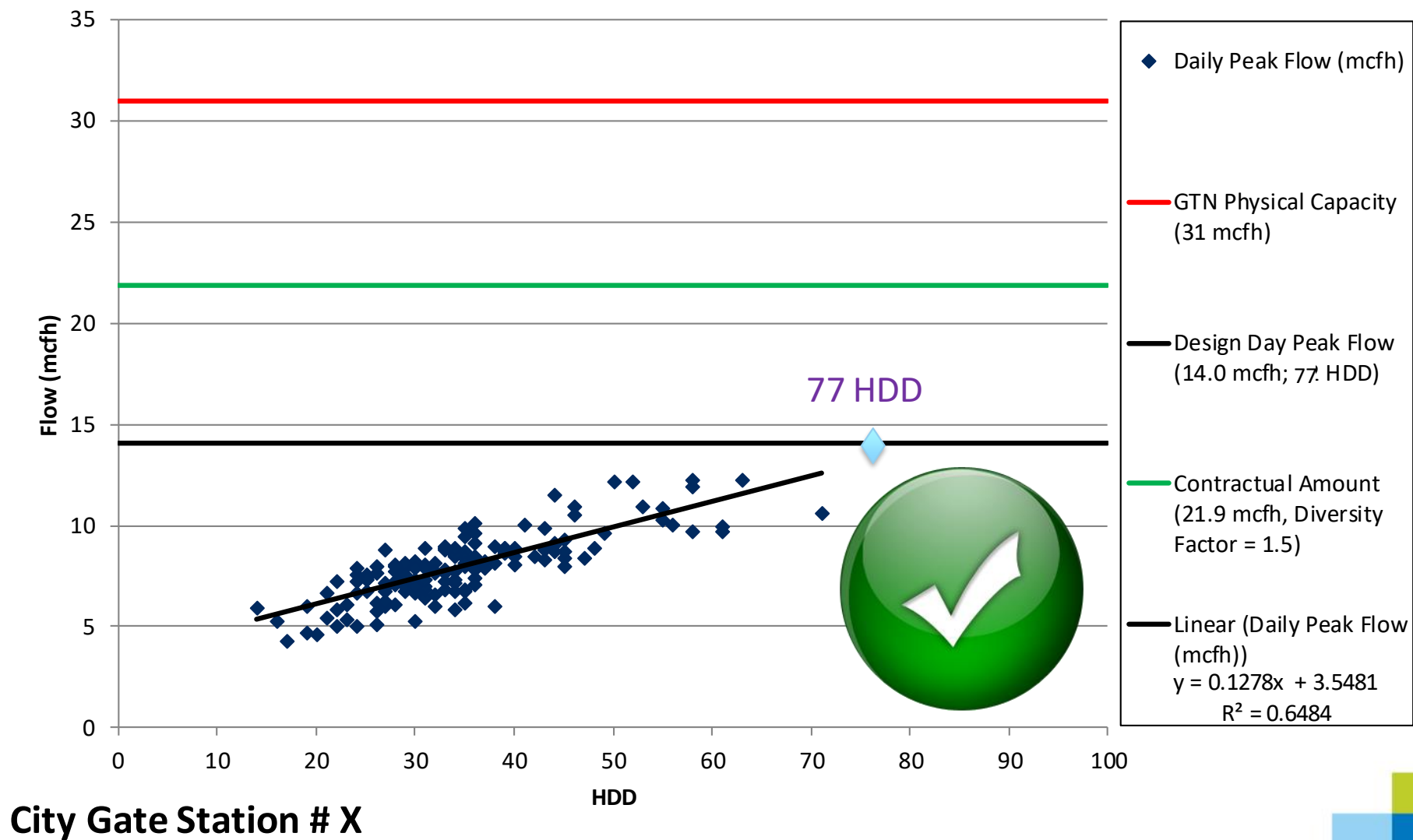

Gate Station Capacity Review (example)

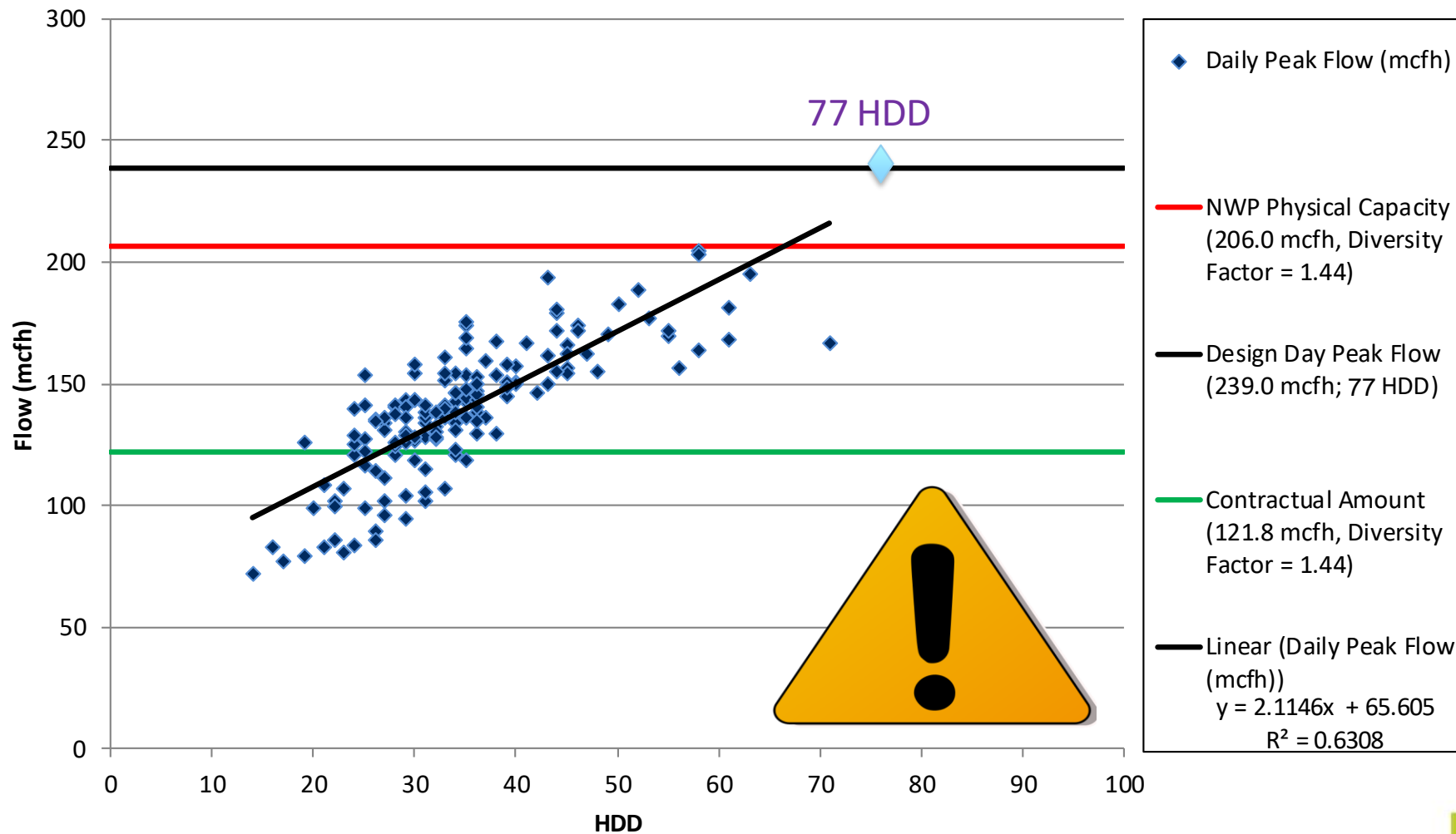

City Gate Station # Y



Recent Projects and Examples



New Agri-Industrial Customer Service Request

Roseburg, OR

Agri-Industrial Customer Service Request

Roseburg, 54 HDD
Before Changes

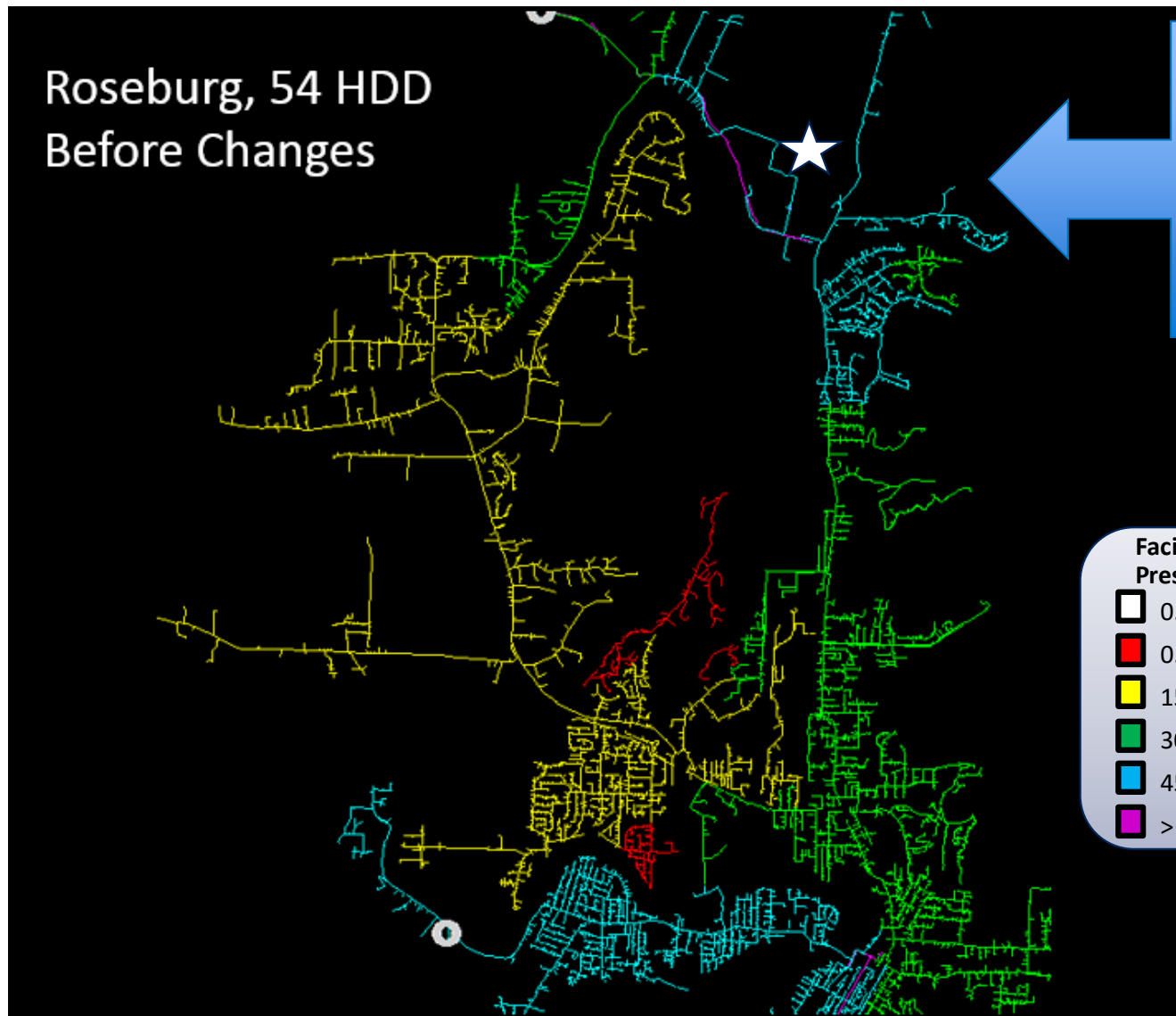

- Conditions:
- 21 Mcfh
 - 15 psig
 - year-round
 - 51 HDD

Facilities Color By:
Pressure (psig)

- 0.00
- 0.01 – 15.00
- 15.01 – 30.00
- 30.01 – 45.00
- 45.01 – 60.00
- > 60.01

Agri-Industrial Customer Service Request

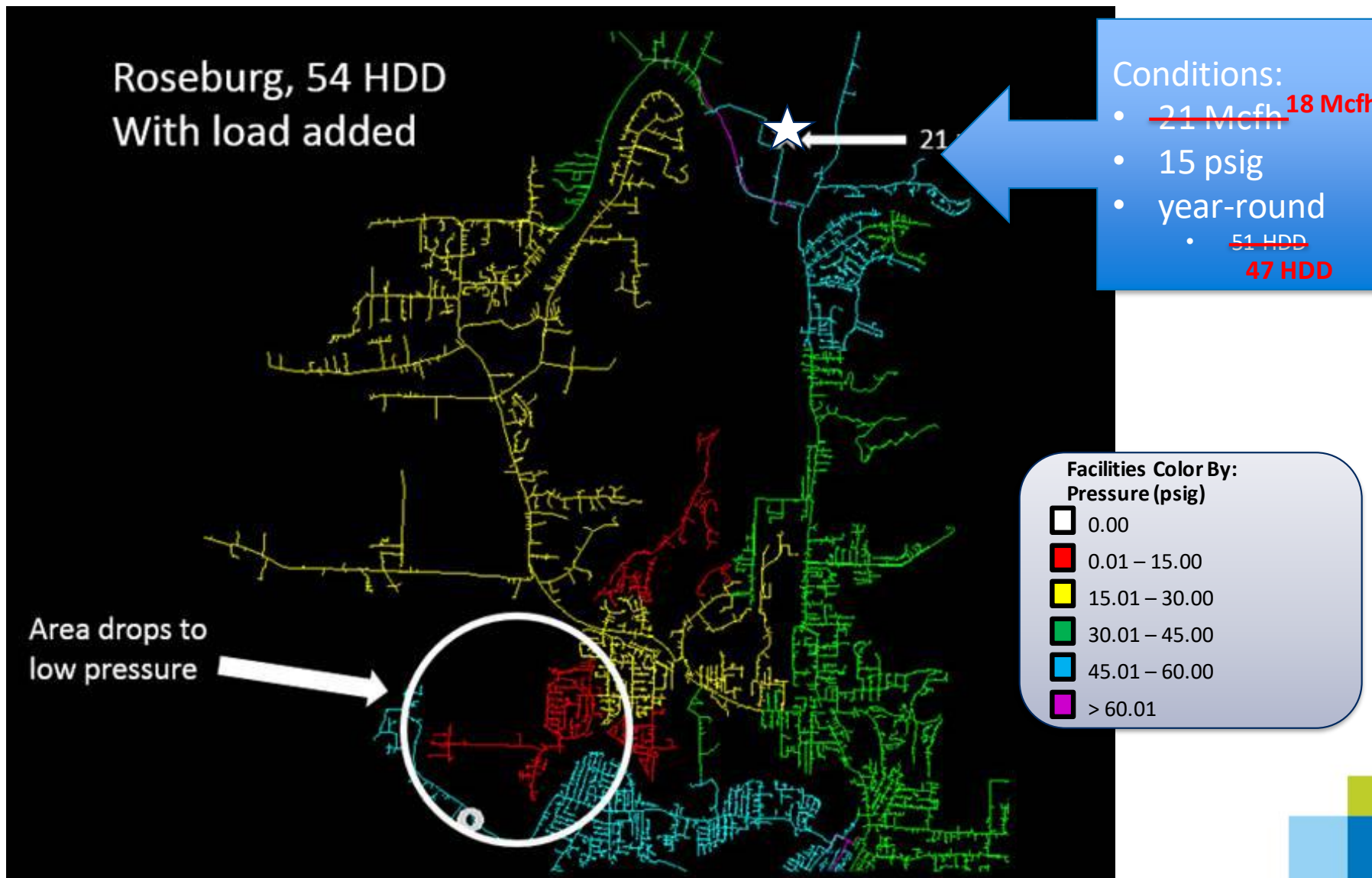



Residential Development Service Request

Deer Park, WA

Residential Development Study

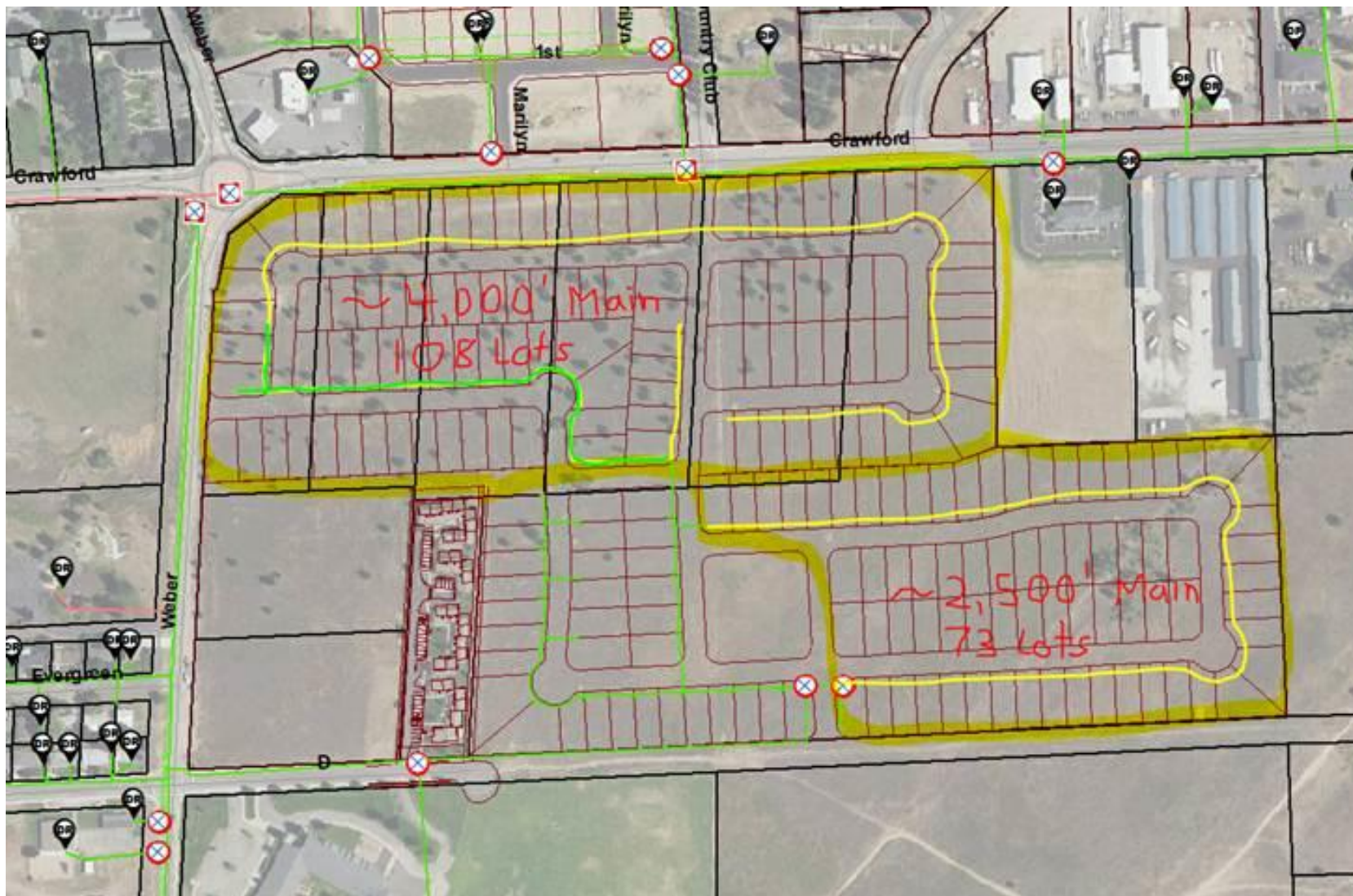

Residential Development Study



Residential Development Study

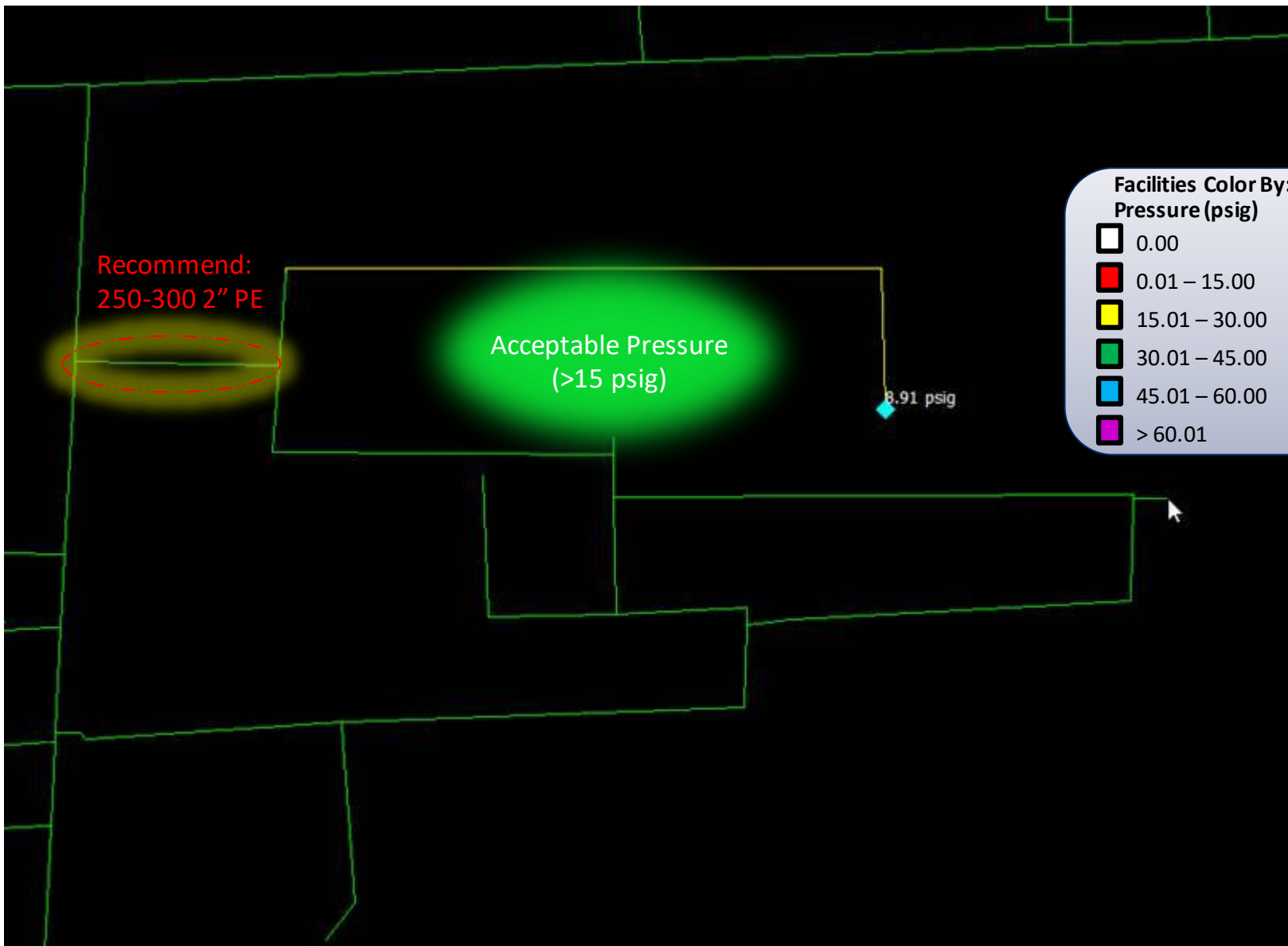



Enbridge Pipeline Rupture Effect on distribution

Medford, OR

Enbridge Pipeline Rupture effect

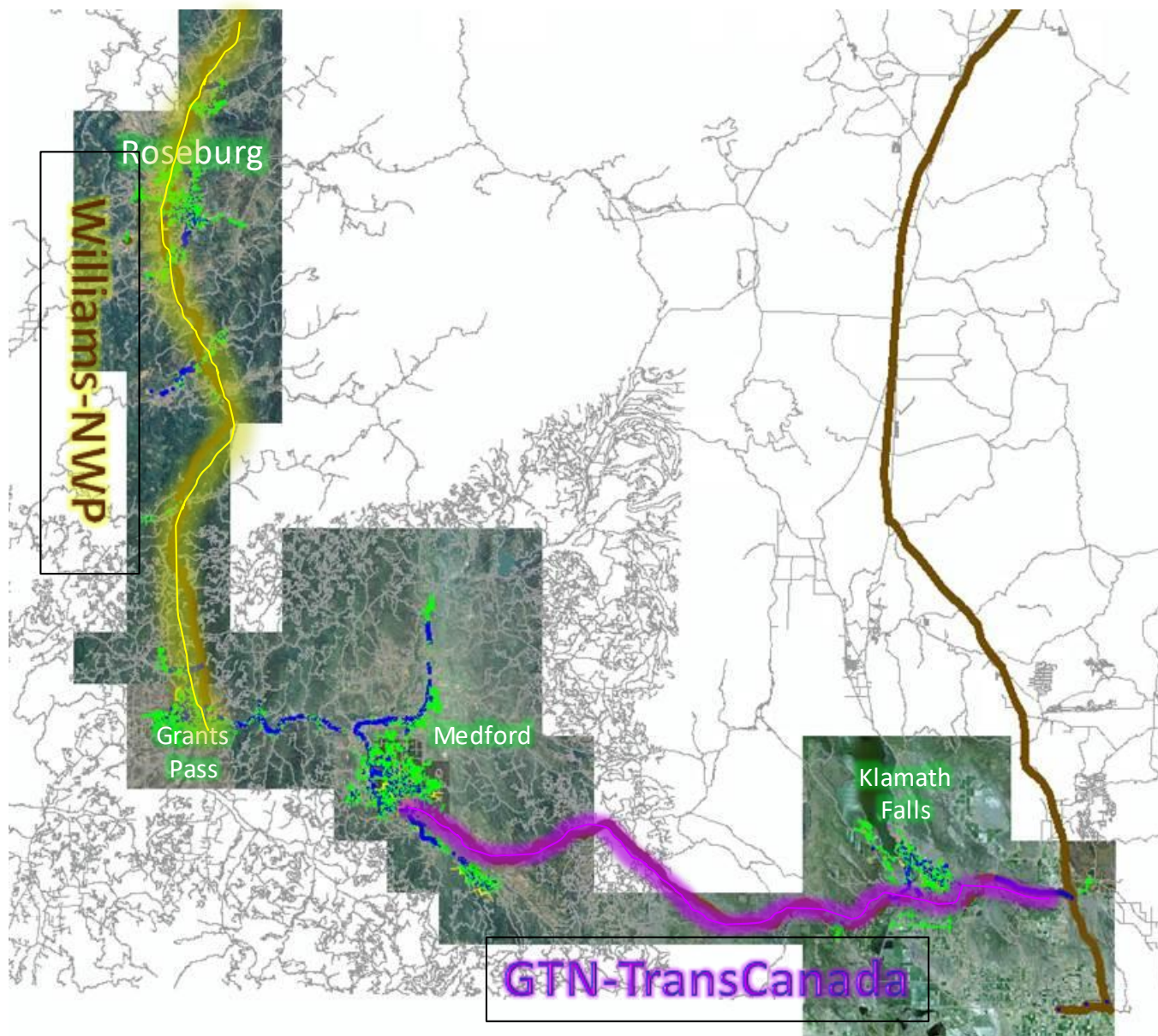

Enbridge Pipeline Rupture effect

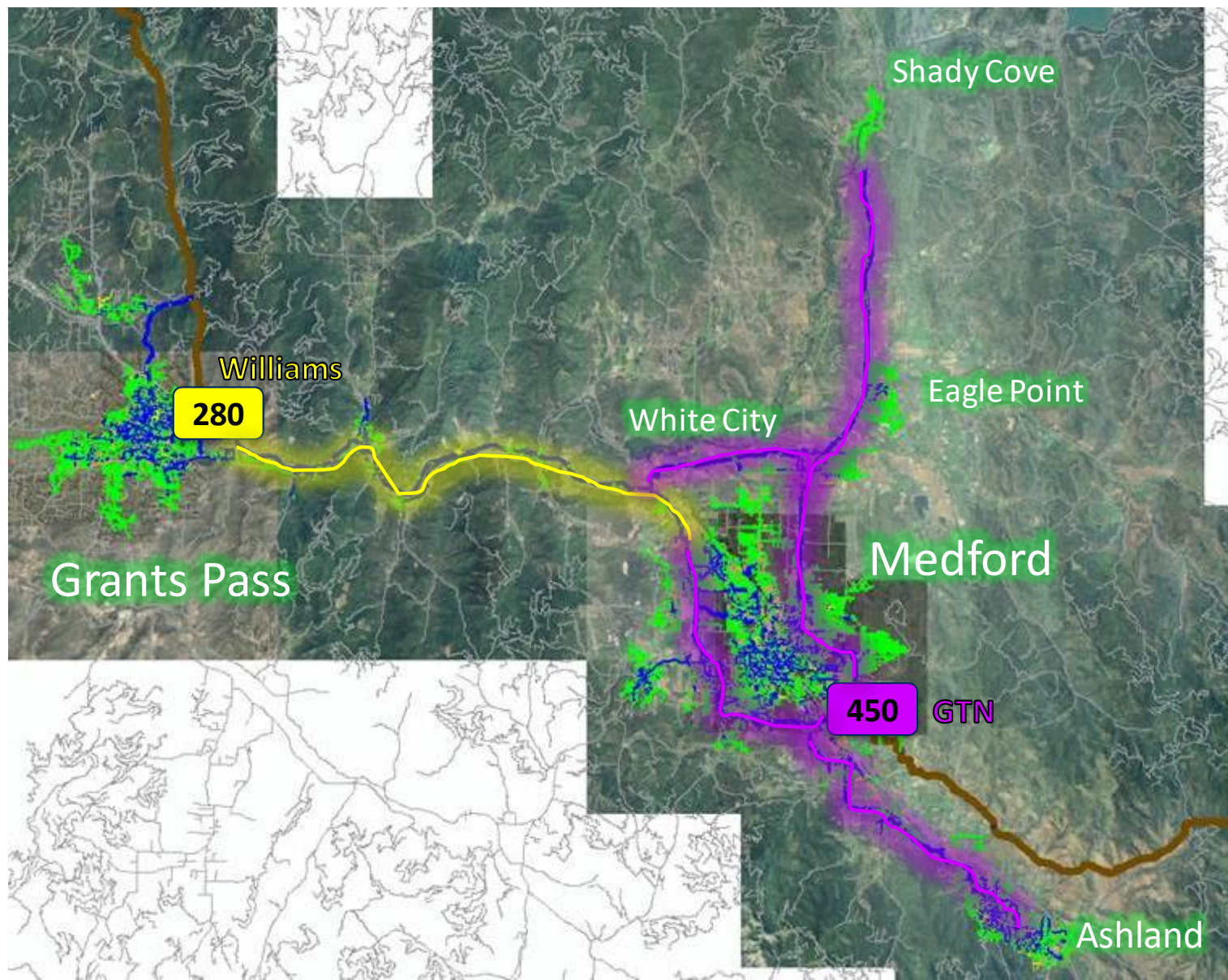

Enbridge Pipeline Rupture effect

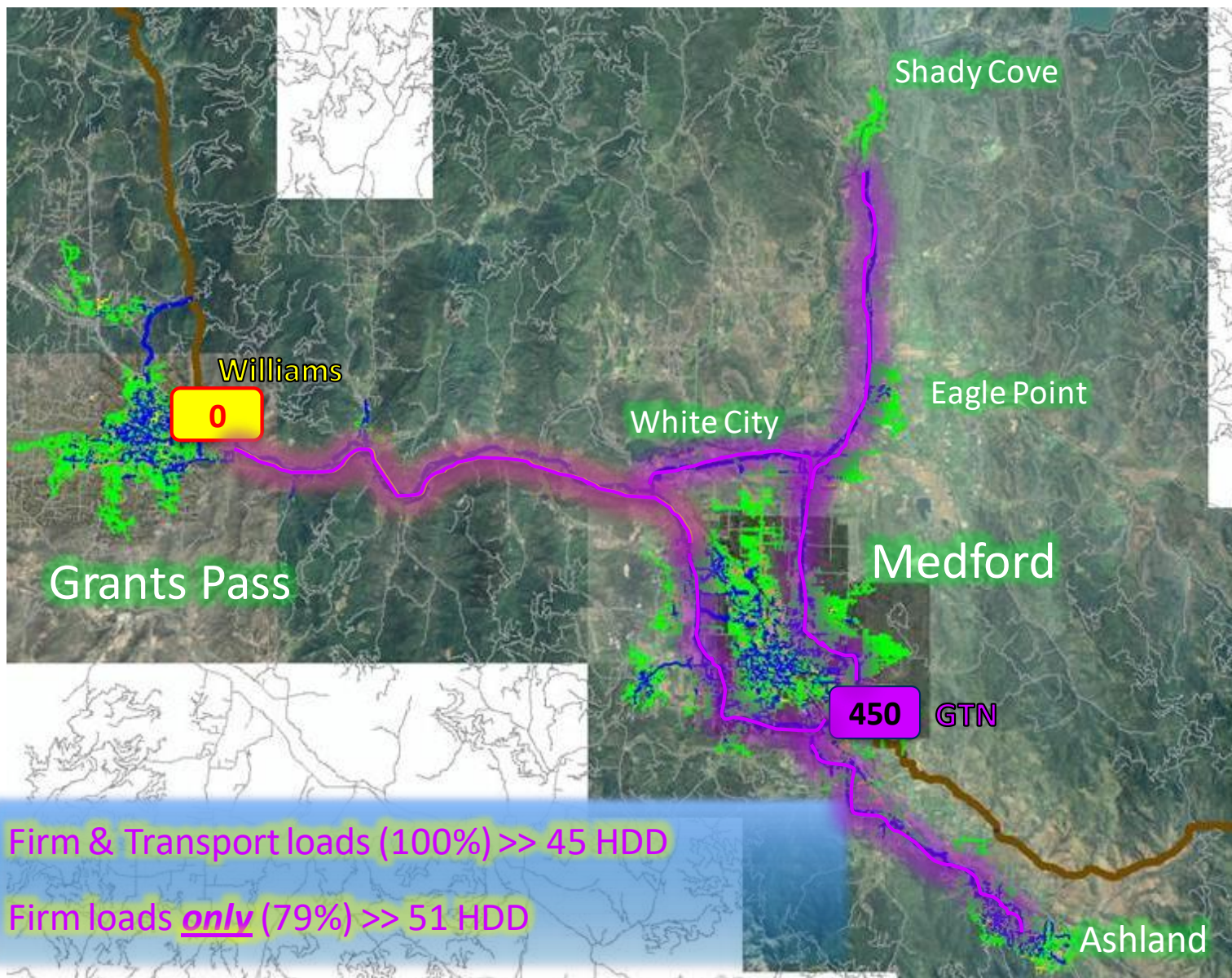

Questions and Discussion

Mission

Using technology to plan and design a safe, reliable, and economical distribution system





Unserved Demand and Supply Side Resource Options

Tom Pardee
Planning Manager, Natural Gas Supply

When unserved demand does show up.....

There are a few questions we need to ask:

1. Why is the demand unserved?
2. What is the magnitude of the short? (i.e Are we 1 Dth or 1000 Dth's short?)
3. What are my options to meet it?

When current resources don't meet demand what could we consider?

- Transport capacity release recalls
- “Firm” backhauls
- Contract for existing available transportation
- Expansions of current pipelines
- Peaking arrangements with other utilities (swaps/mutual assistance agreements) or marketers
- In-service territory storage
- Satellite/Micro LNG (storage inside service territory)
- Large scale LNG with corresponding pipeline build into our service territory
- Structured products/exchange agreements delivered to city gates
- Biogas (assume it's inside Avista's distribution)
- Hydrogen blend (assume it's inside Avista's distribution)
- Avista distribution system enhancements
- Demand side management

New Resource Risk Considerations

- Does it get supply to the gate?
- Is it reliable/firm?
- Does it have a long lead time?
- How much does it cost?
 - New build vs. depreciated cost
 - The rate pancake
- Is it a base load resource or peaking?
- How many dekatherms do I need?
- What is the “shape” of resource?
- Is it tried and true technology, new technology, or yet to be discovered?
- Who else will be competing for the resource?

Potential New Supply Resources Considerations

- Availability
 - By Region – which region(s) can the resource be utilized?
 - Lead time considerations – when will it be available?
- Type of Resource
 - Peak vs. Base load
 - Firm or Non-Firm
 - “Lumpiness”
- Usefulness
 - Does it get the gas where we need it to be?
 - Last mile issues
- Cost

Regional Infrastructure – Potential Projects

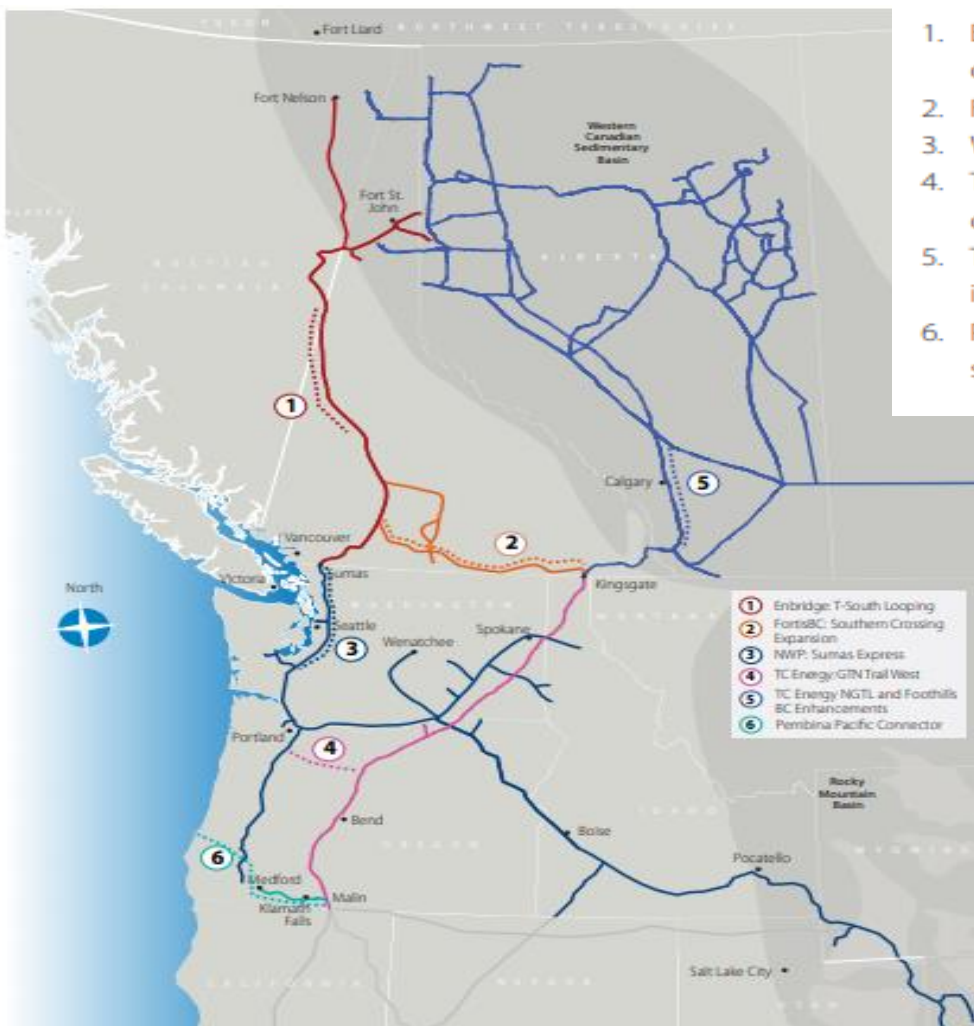

1. Enbridge T-South expansion: addition of 190 million cubic feet per day (MMcf/d) of firm capacity.
2. FortisBC Southern Crossing expansion: addition of 300-400 MMcf/d of bidirectional capacity.
3. Williams Northwest Pipeline (NWP) Sumas Express: still under assessment.
4. TC Energy Gas Transmission Northwest (GTN) Trail West/N-Max: addition of 500 MMcf/d capacity, expandable to 1,000 MMcf/d.
5. TC Energy other system enhancements: two projects to add a combined 525 MMcf/d of incremental firm transportation to the Alberta/BC export delivery point.
6. Pembina Pacific Connector Gas Pipeline (PCGP) Project: Addition of 1,000 MMcf/d capacity to serve proposed Coos Bay LNG export facility.

Supply Resources - Modeled

Additional Resource	Size	Cost/Rates			Availability	Notes
Unsubscribed GTN Capacity	Up to 50,000 Dth	GTN Rate			Now	Currently available unsubscribed capacity from Kingsgate to Spokane
Medford Lateral Exp	50,000 Dth / Day	\$35M capital + GTN Rate			2022	Additional compression to facilitate more gas to flow from mainline GTN to Medford
Hydrogen	166 Dth / Day	WA	ID	OR	Varies	Cost estimates obtained from a consultant; levelized cost includes revenue requirements, expected carbon adder and assumed retail power rate Costs estimates obtained from a consultant for each specific type of RNG; levelized costs include revenue requirements, distribution costs, and projected carbon intensity adder/(savings). This cost also includes any incentives from bills such as Washington House Bill 2580 or Oregon Senate Bill 334
		\$48 / Dth	\$40 / Dth	\$46 / Dth		
Renewable Natural Gas – Distributed Landfill	635 Dth / Day	WA	ID	OR	Varies	
		\$13 / Dth	\$13 / Dth	\$13 / Dth		
Renewable Natural Gas – Centralized Landfill	1,814 Dth / Day	WA	ID	OR	Varies	
		\$11 / Dth	\$11 / Dth	\$12 / Dth		
Renewable Natural Gas – Dairy	635 Dth / Day	WA	ID	OR	Varies	
		\$34 / Dth	\$39 / Dth	\$33 / Dth		
Renewable Natural Gas – Waste Water	513 Dth / Day	WA	ID	OR	Varies	
		\$19 / Dth	\$18 / Dth	\$19 / Dth		
Renewable Natural Gas – Food Waste to (RNG)	298 Dth / Day	WA	ID	OR	Varies	
		\$38 / Dth	\$39 / Dth	\$38 / Dth		
Plymouth LNG	241,700 Dth w/70,500 Dth deliverability	NWP Rate			Now	Provides for peaking services and alleviates the need for costly pipeline expansions Pair with excess pipeline MDDO's to create firm transport

Future Supply Resources – Not Modeled

Other Resources to Consider

Additional Resource	Size	Cost/Rates	Availability	Notes
Co. Owned LNG	600,000 Dth w/ 150,000 of deliverability	\$75 Million plus \$2 Million annual O&M	2024	On site, in service territory liquefaction and vaporization facility
Various pipelines – Pacific Connector, Trails West, NWP Expansion, GTN Expansion, etc.	Varies	Precedent Agreement Rates	2022	Requires additional mainline capacity on NWPL or GTN to get to service territory
Large Scale LNG	Varies	Commodity less Fuel	2024	Speculative, needs pipeline transport
In Ground Storage	Varies	Varies	Varies	Requires additional mainline transport to get to service territory



Carbon Costs

Tom Pardee
Planning Manager, Natural Gas Supply

Cost of Carbon and Sendout

- Monthly costs are loaded into SENDOUT
- These costs will differ based on the requirements or an expected program type by state
- These costs are input at the transportation level in order to correctly account for the cost of carbon in each area regardless of supply basin

Social Cost of Carbon

Figure ES-1: Frequency Distribution of SC-CO₂ Estimates for 2020³

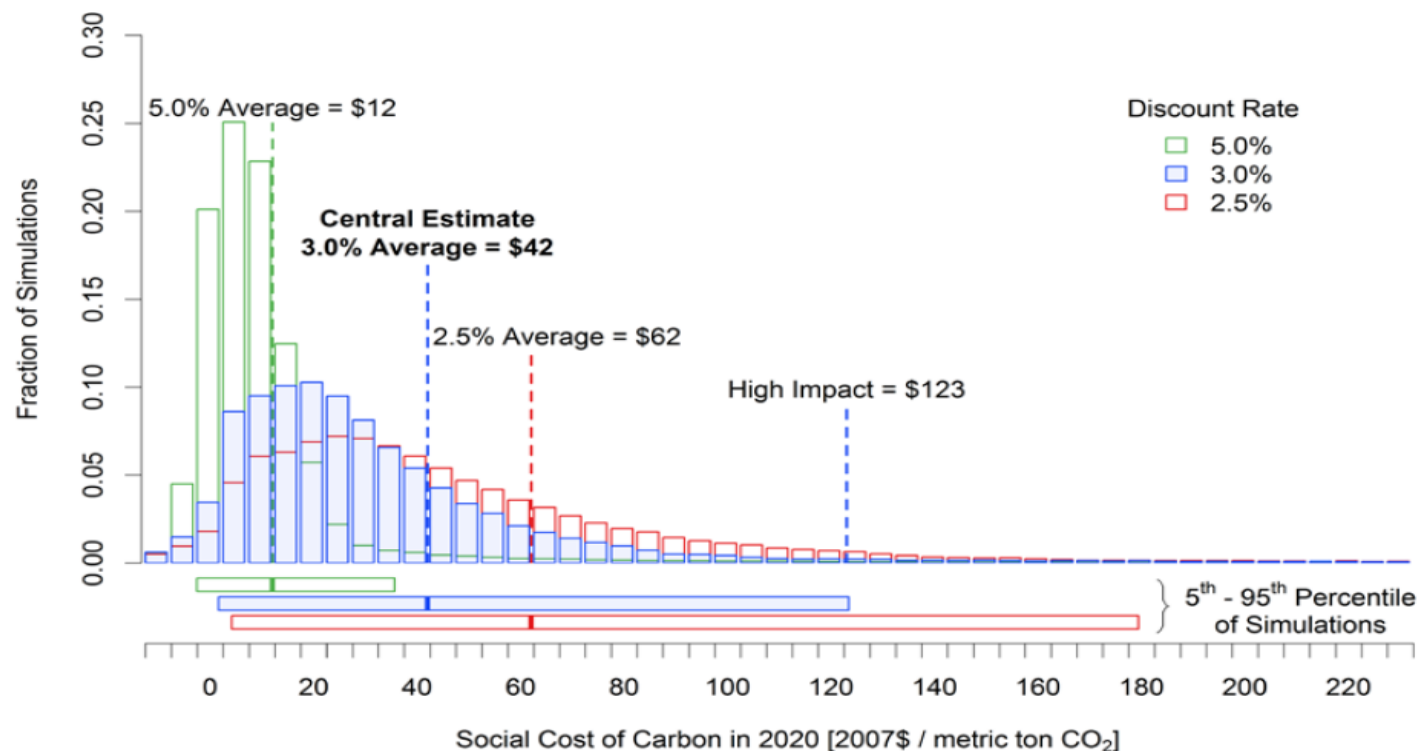

- Social cost of carbon dioxide in 2007 dollars using the 2.5% discount rate, listed in table 2, [technical support document](#): Technical update of the social cost of carbon for regulatory impact analysis under Executive Order No. 12866, published by the interagency working group on social cost of greenhouse gases of the United States government, August 2016.

Washington – Carbon adder

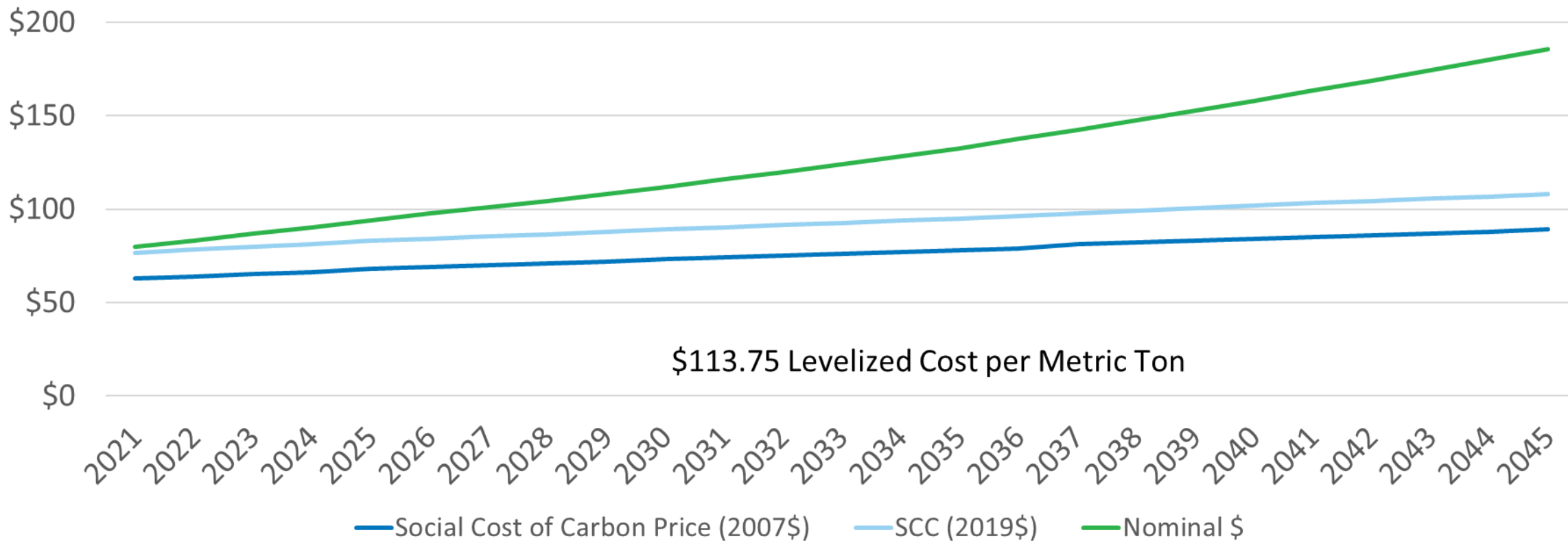

- Social cost of carbon dioxide in 2007 dollars using the 2.5% discount rate, listed in table 2, [technical support document](#): Technical update of the social cost of carbon for regulatory impact analysis under Executive Order No. 12866, published by the interagency working group on social cost of greenhouse gases of the United States government, August 2016.
- Adjust to 2019\$ using Bureau of Economics GDP
- Adjust to Nominal \$ using 2.11% annual inflation rate

Oregon – Carbon adder

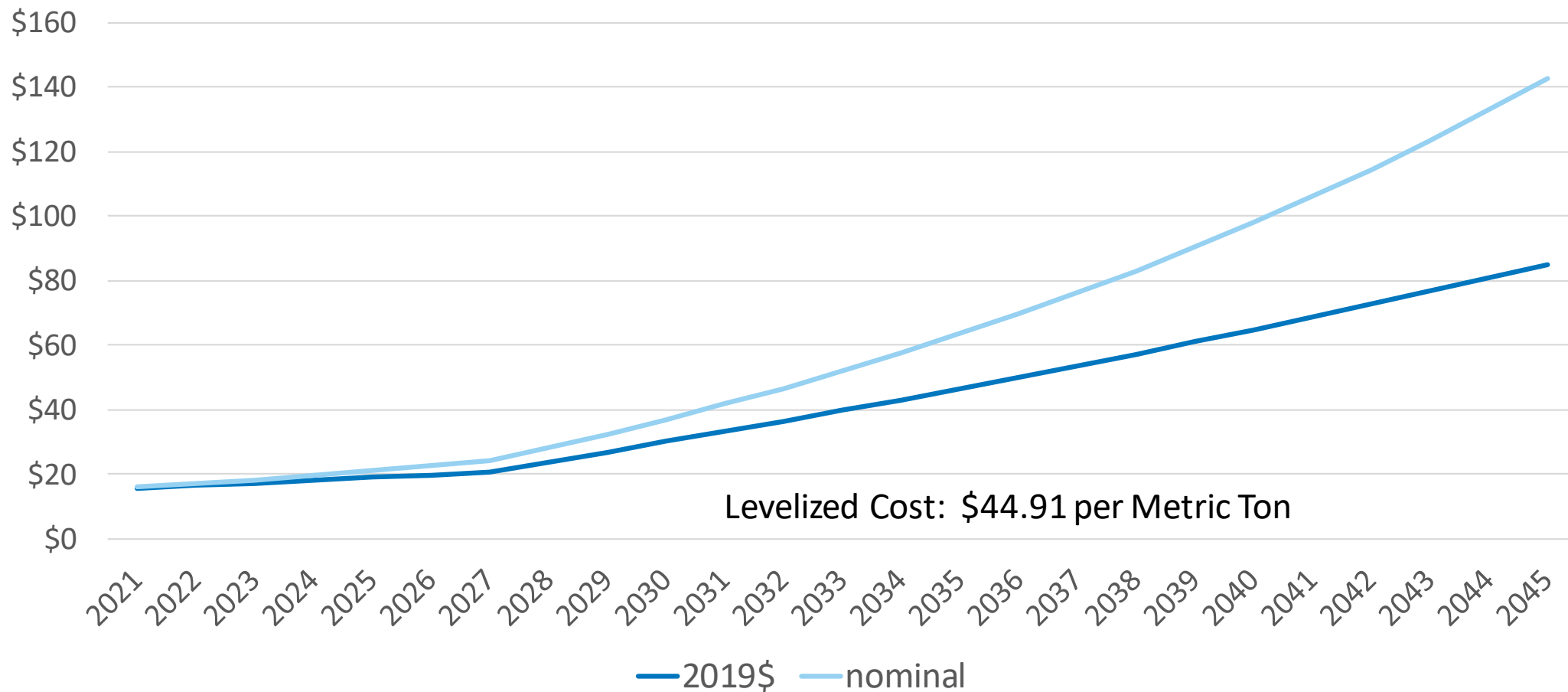

Source: Wood Mackenzie North America gas markets long-term outlook – H1 2020

*Modeled as an expected cost of California’s cap and trade program



All jurisdictions - Carbon adder

High sensitivity

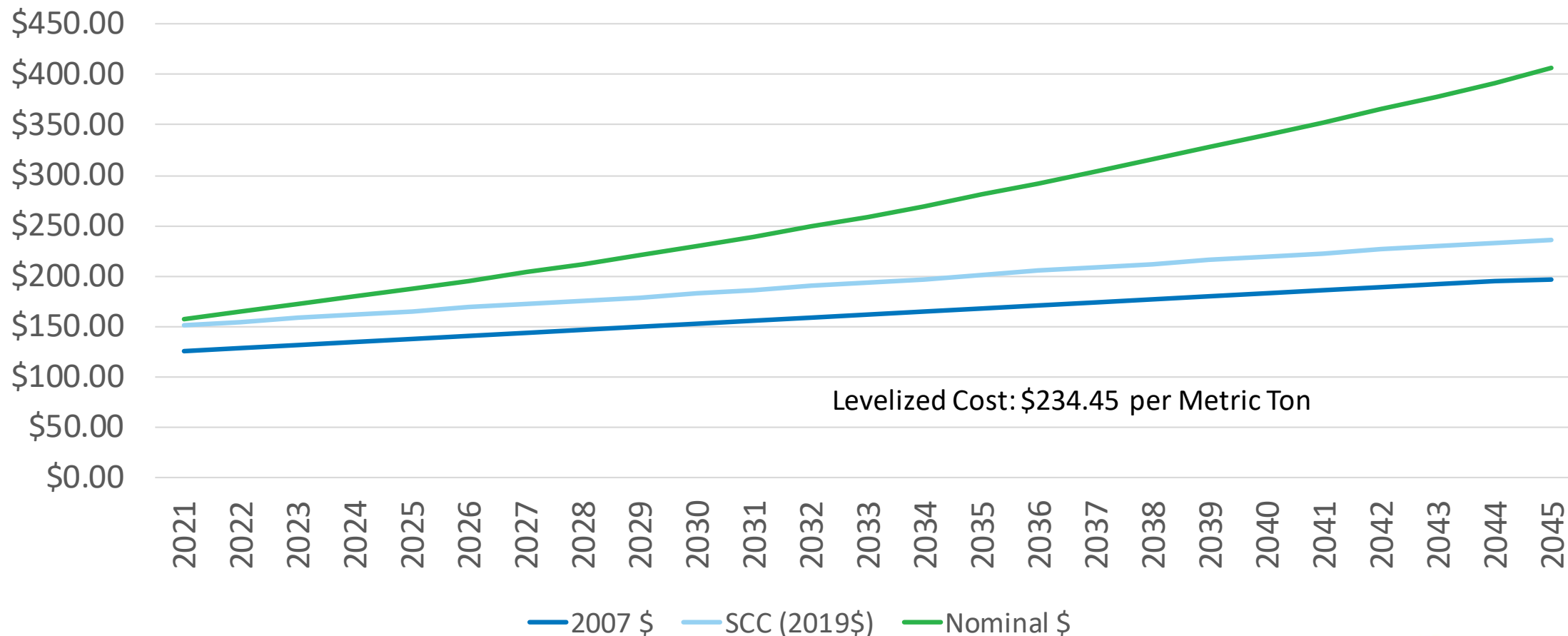

- EPA = [Social Cost of Carbon](#)
- Adjust to 2019\$ using Bureau of Economics GDP
- Adjust to Nominal \$ using 2.11% annual inflation rate

High Carbon Scenario - SCC @ 95% @ 3%



Carbon Costs

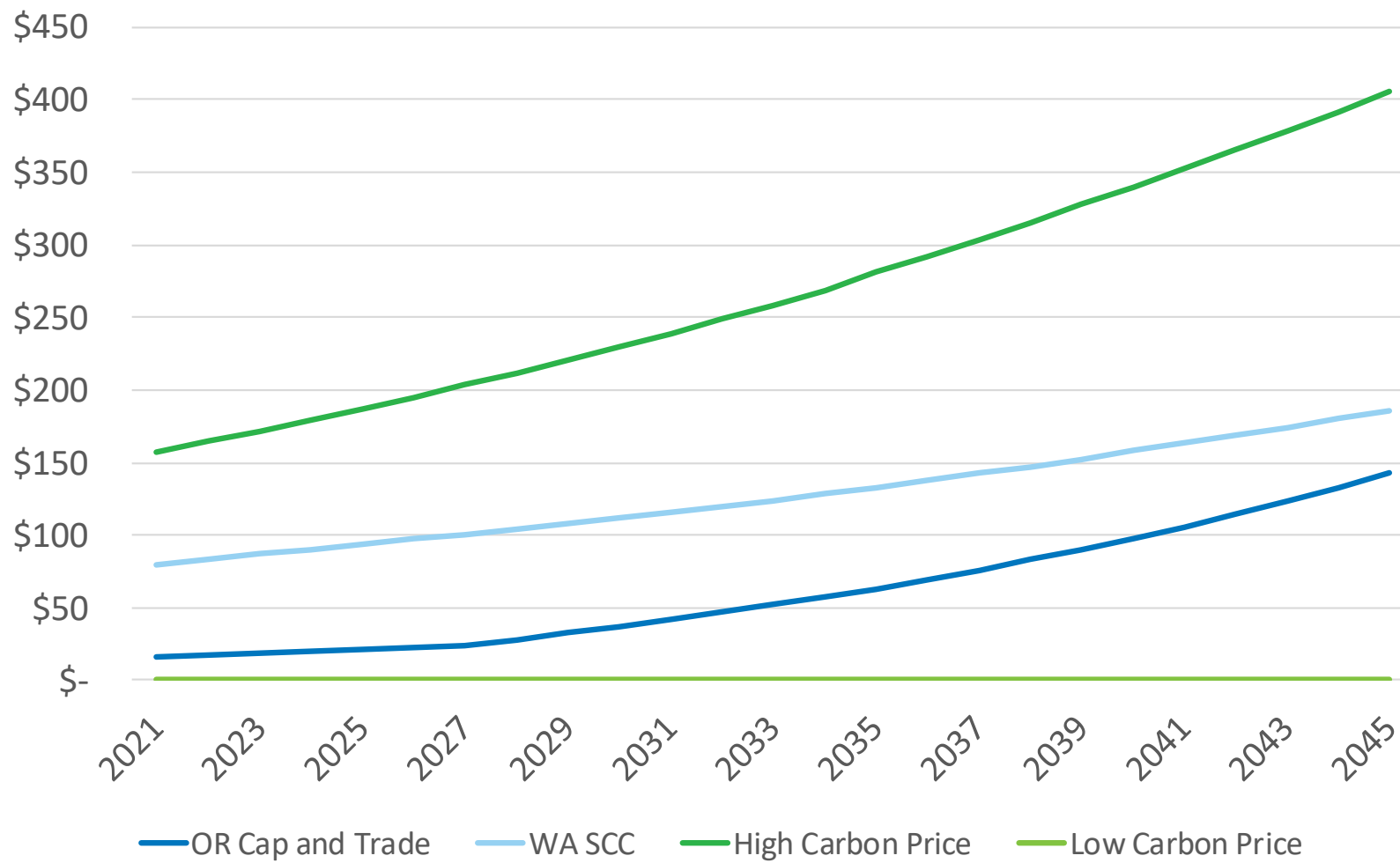

Levelized Cost
per MTCO₂e

\$44.92

\$113.75

\$234.45

\$0



Expected Case

Cost of Carbon by State - Summary

- Washington - Social cost of carbon @ 2.5% discount rate;
 - upstream emissions associated with natural gas drilling and transportation of natural gas to its end use.
- Oregon is based off a Wood Mackenzie estimate for Cap and Trade
- Idaho - carbon prices will not be included



Price Elasticity

Tom Pardee
Planning Manager, Natural Gas Supply

Price Elasticity

Price elasticity is a method used by economists to measure how supply or demand changes based on changes in price.

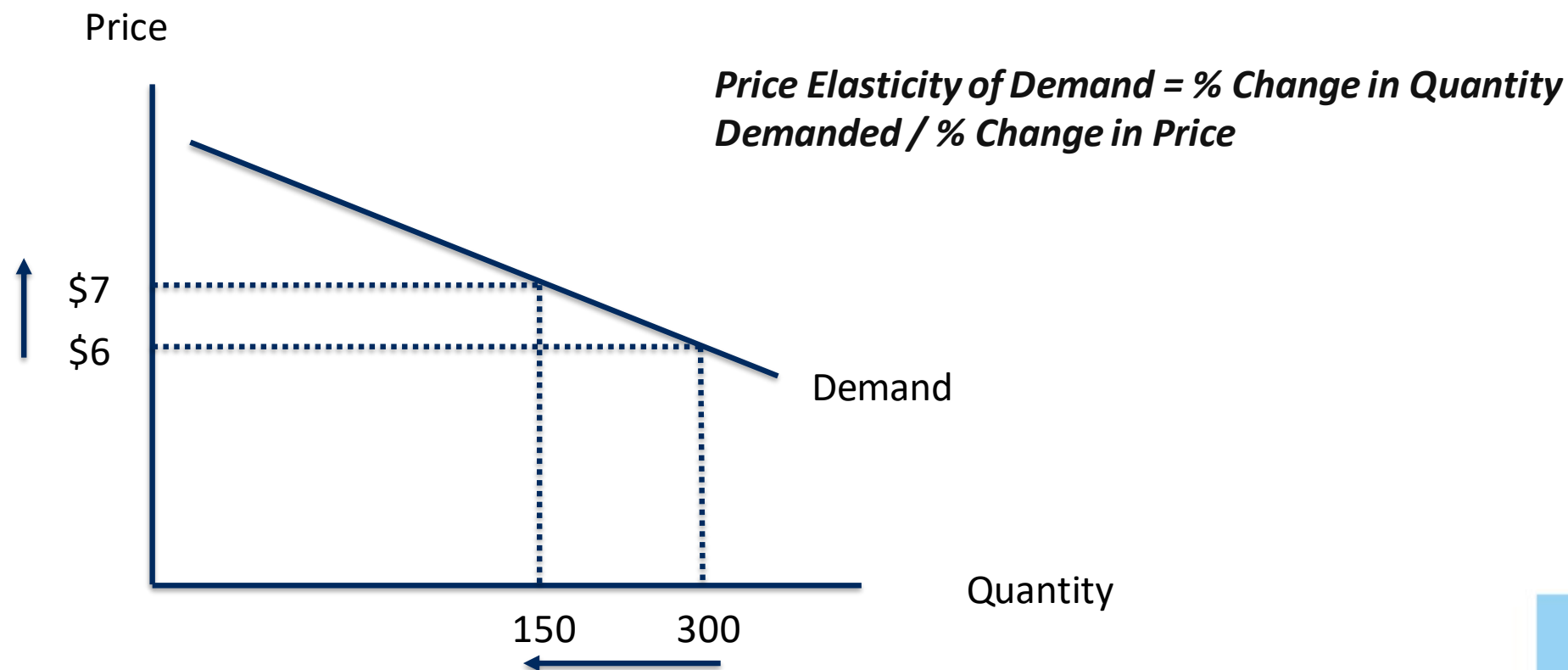

Price Elasticity Factors Defined

- Price elasticity is usually expressed as a numerical factor that defines the relationship of a consumer's consumption change in response to price change.
- Typically, the factor is a **negative** number as consumers normally **reduce** their consumption in response to **higher** prices or will **increase** their consumption in response to **lower** prices.
 - For example, a price elasticity factor of -0.081 means:
 - A 10% price **increase** will prompt a 0.81% consumption **decrease**
 - A 10% price **decrease** will prompt a 0.81% consumption **increase**

Summary

- The elasticity as measured in the Medford and Roseburg areas will be used for the entire system as estimated elasticity.
- 0.81% decrease only for each price rise of 10%
- This elasticity is measured through heat coefficients and annual price changes



Sensitivities

Michael Brutocao
Analyst, Natural Gas Supply

Sensitivities Summary

Influence Type	Sensitivity	Customer Growth Rate	Use per Customer	Weather	Demand Side Management	Prices	Elasticity	First Year System Unserved	Location Unserved
DEMAND INFLUENCING - DIRECT	Reference	Reference	3 Year Historical	20 Year Average	None	Expected	None	-	-
	Reference Plus Peak			2035				Washington	
	Low Cust	Low Growth		Planning Standard				-	-
	High Cust	High Growth		Coldest in 20yrs				2029	Washington
	Alternate Weather Standard	Reference	3 Year Historical	20 Year Average	Expected			-	-
	DSM			2039				Idaho	
	Peak plus DSM		2 Year Historical	Planning Standard	None			-	-
	80% below 1990 emissions – OR/WA only							2035	Washington
	2 Year use per customer Alternate		5 Year Historical		2035			Washington	
	5 Year use per customer Alternate		3 Year Historical		2035			Washington	
	JP Outage Only (0% capacity)				2021			Washington	
	AECO Outage Only (0% capacity)				2020			WA, ID	
	Sumas Outage Only (0% capacity)				2020			Medford	
	Rockies Outage Only (0% capacity)				2020			La Grande	
	JP Outage Only (50% capacity)	2021			Washington				
	AECO Outage Only (50% capacity)	2026			Washington				
	Sumas Outage Only (50% capacity)	2025		Washington					
	Rockies Outage Only (50% capacity)	2025		La Grande					
	NWP Outage (0% capacity)	2020		WA, ID, La Grande					
	GTN Outage (0% capacity)	2020	WA, ID, Klamath Falls						
NWP Outage (50% capacity)	2020	WA, La Grande							
GTN Outage (50% capacity)	2026	Washington							



Sensitivities Summary (Continued)

Influence Type	Sensitivity	Customer Growth Rate	Use per Customer	Weather	Demand Side Management	Prices	Elasticity	First Year System Unserved	Location Unserved
PRICE INFLUENCING - INDIRECT	Expected Prices	Reference	3 Year Historical	Planning Standard	None	Expected	Expected	-	-
	Low Prices					Low		-	-
	High Prices					High		-	-
	Carbon Cost - High (SCC 95% at 3%)							-	-
	Carbon Cost - Expected (SCC 2.5% (WA) & Cap&Red (OR))							-	-
	Carbon Cost - Low \$0							-	-
EMISSIONS INFLUENCING	High Upstream Emissions 2.47% leakage (EDF study)					Expected		-	-
	Expected Upstream Emissions (0.79% leakage)							-	-
	No Upstream Emissions							-	-
	Expected Global Warming Potential (20 Years)							-	-
	Expected Global Warming Potential (100 Years)							-	-

First Year Peak Demand Unserved (11/1/2020 – 10/31/2040)

	Washington	Idaho	La Grande	Medford	Klam Falls	Roseburg
Reference Plus Peak	2035	2039				
High Customer Growth	2029	2038	2035			
Alternate Weather Standard	2035					
Reference Plus Peak Plus DSM		2039				
2-yr Use Per Customer	2035	2039				
5-yr Use Per Customer	2035					
Outage (JP - 0%)	2021	2022		2028		
Outage (JP - 50%)	2021					
Outage (AECO - 0%)	2020	2020				
Outage (AECO - 50%)	2026	2028				
Outage (Sumas - 0%)	2026	2021		2020		2032
Outage (Sumas - 50%)	2025	2038		2035		
Outage (Rockies - 0%)	2021	2023	2020	2031		2033
Outage (Rockies - 50%)	2028	2039	2025			
Outage (NWP - 0%)	2020	2020	2020	2021		2028
Outage (NWP - 50%)	2020	2023	2020	2029		
Outage (GTN - 0%)	2020	2020		2026	2020	2028
Outage (GTN - 50%)	2026	2028				

***Sensitivities not listed above have no unserved demand.**

Demand Sensitivities: Weather

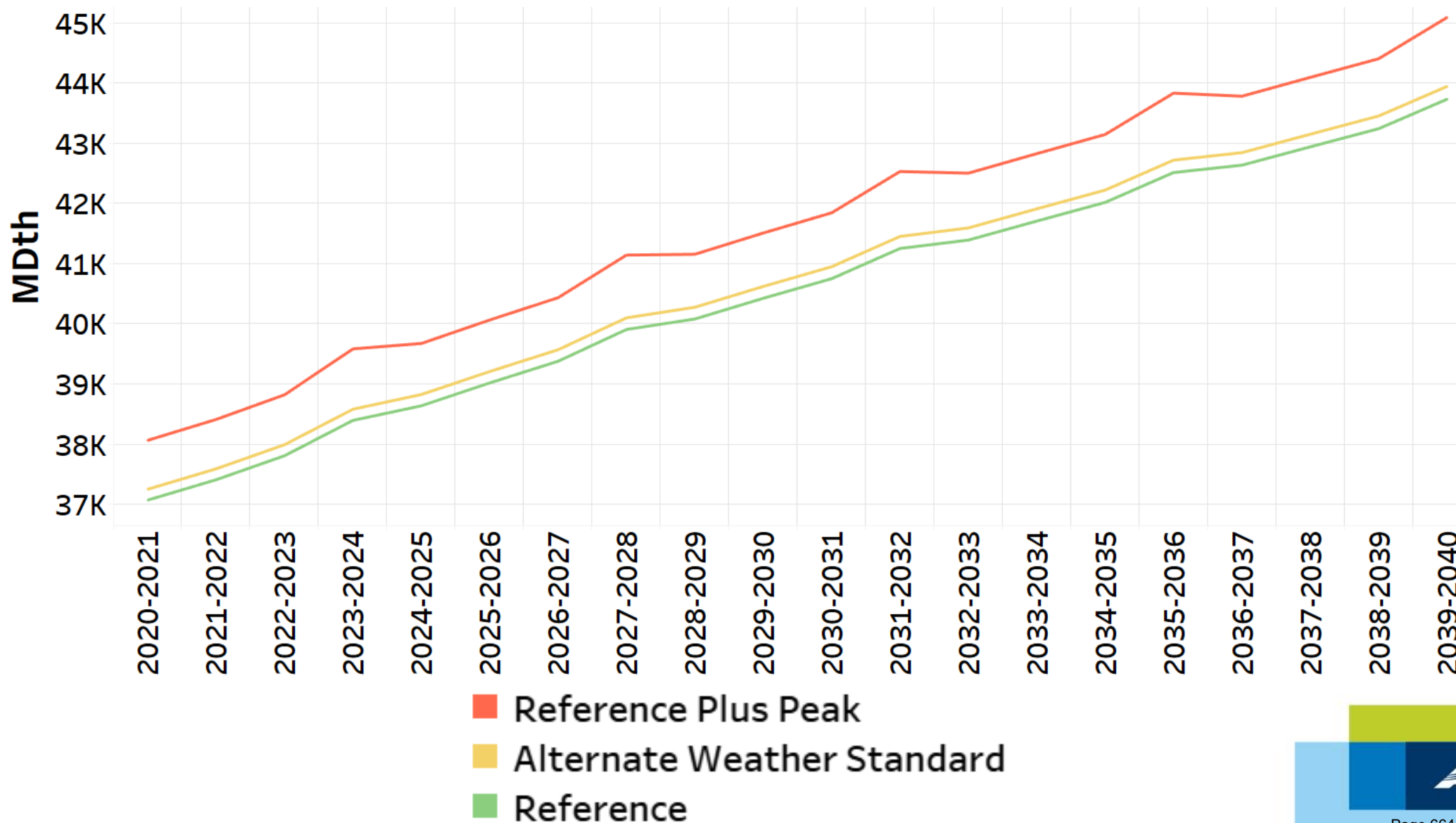

Demand Sensitivities: 80% Below 1990 Emissions

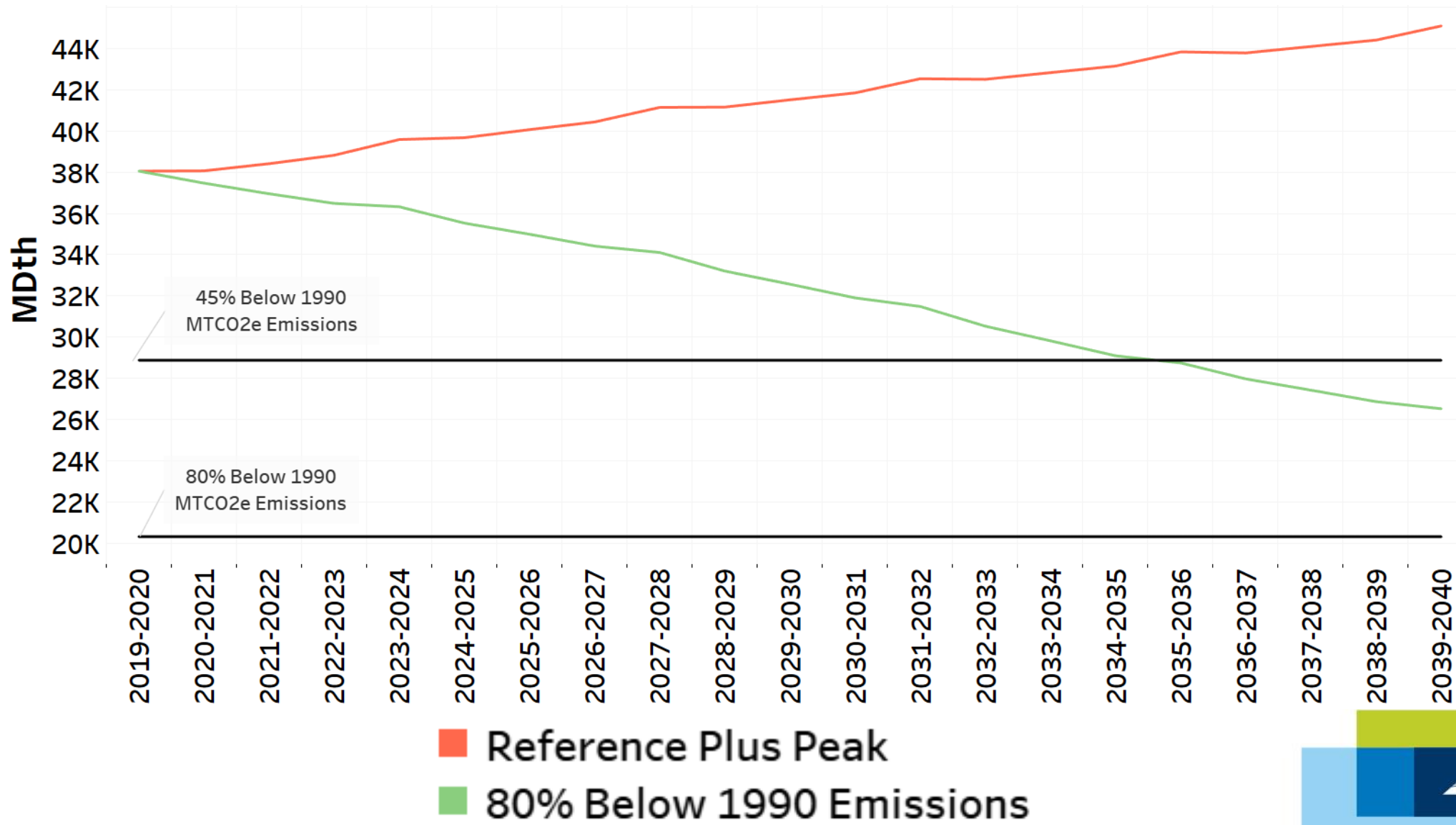

Demand Sensitivities: Demand Side Management

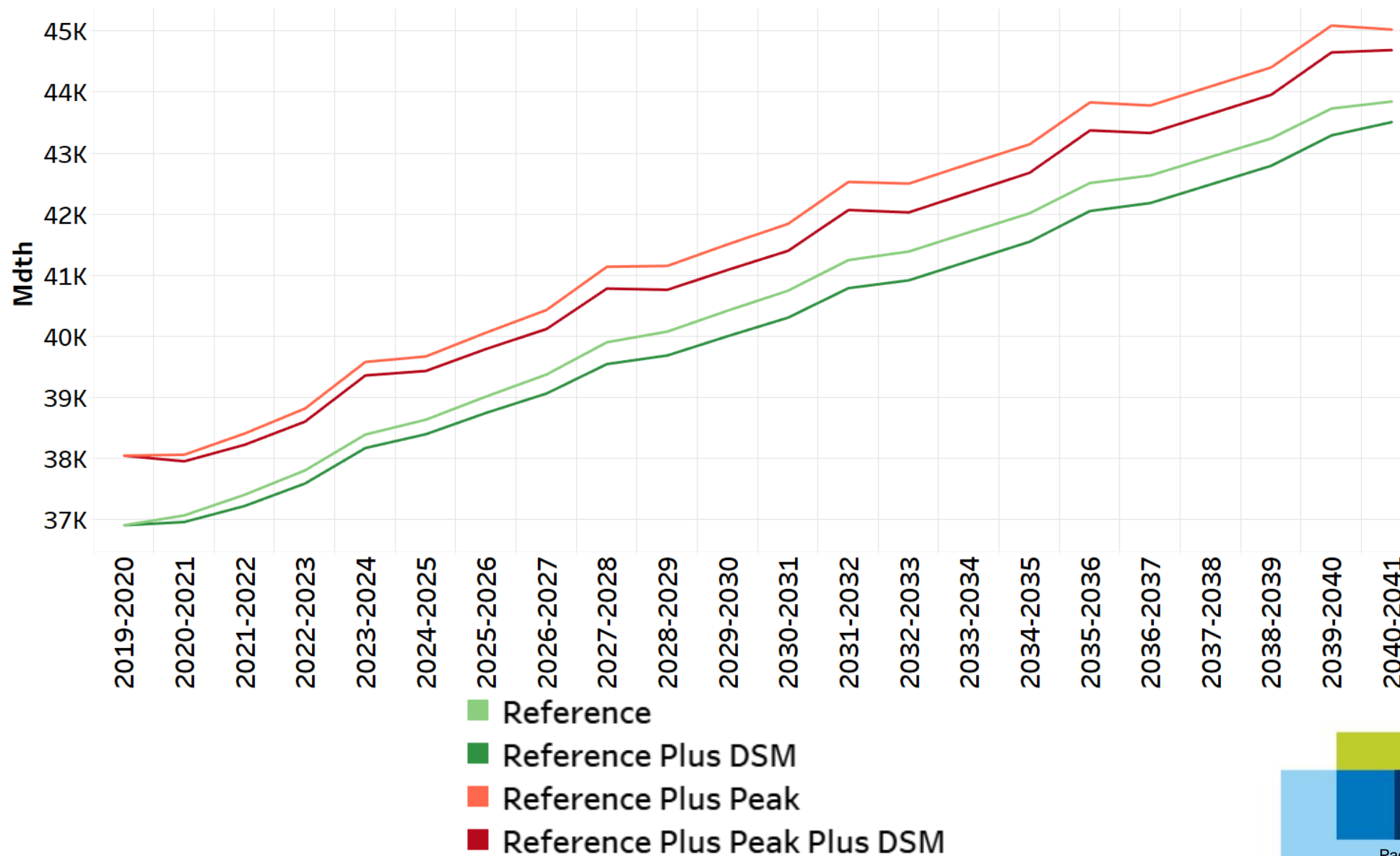

Demand Sensitivities: Use Per Customer

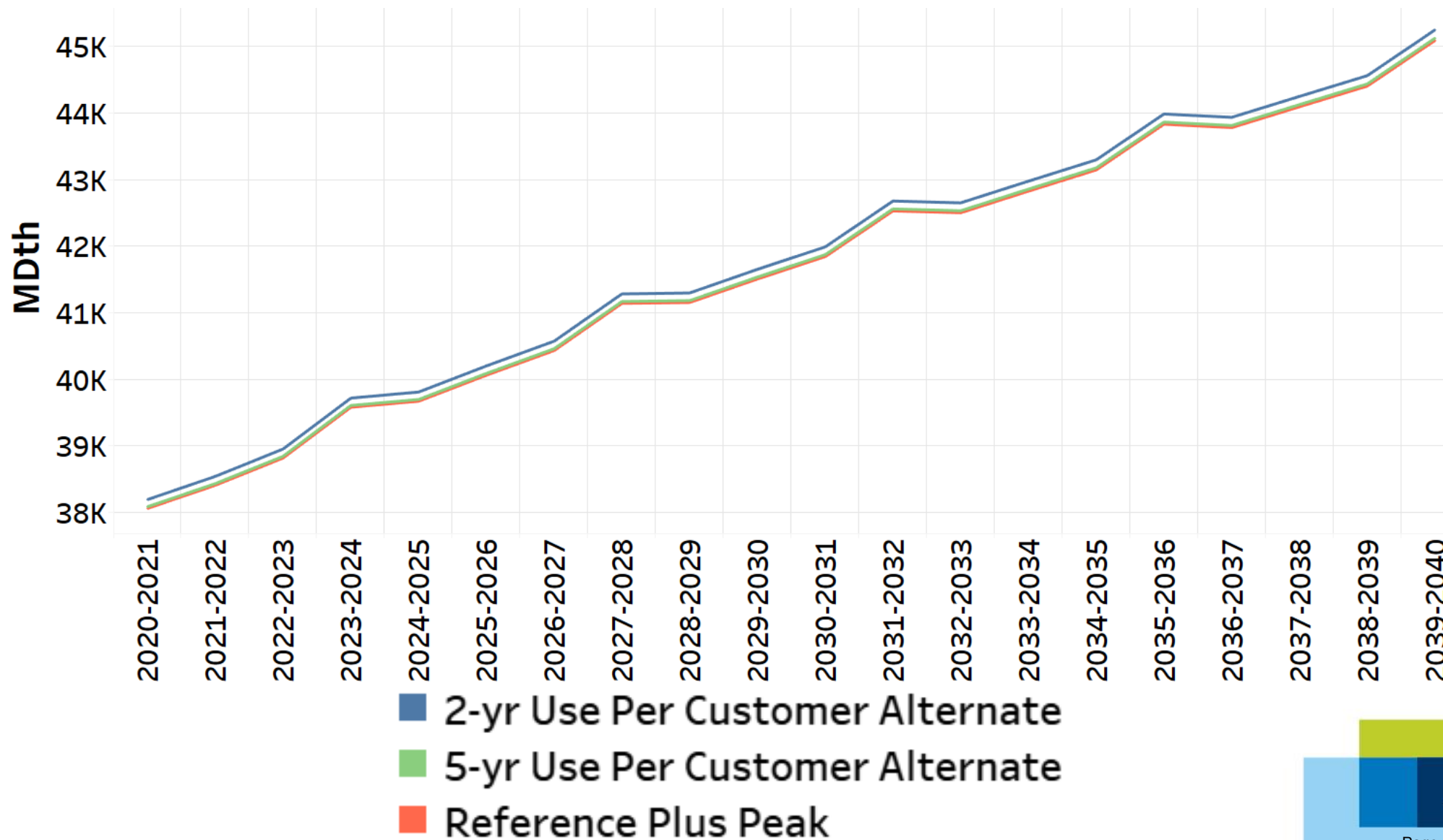

Demand Sensitivities: Customer Growth

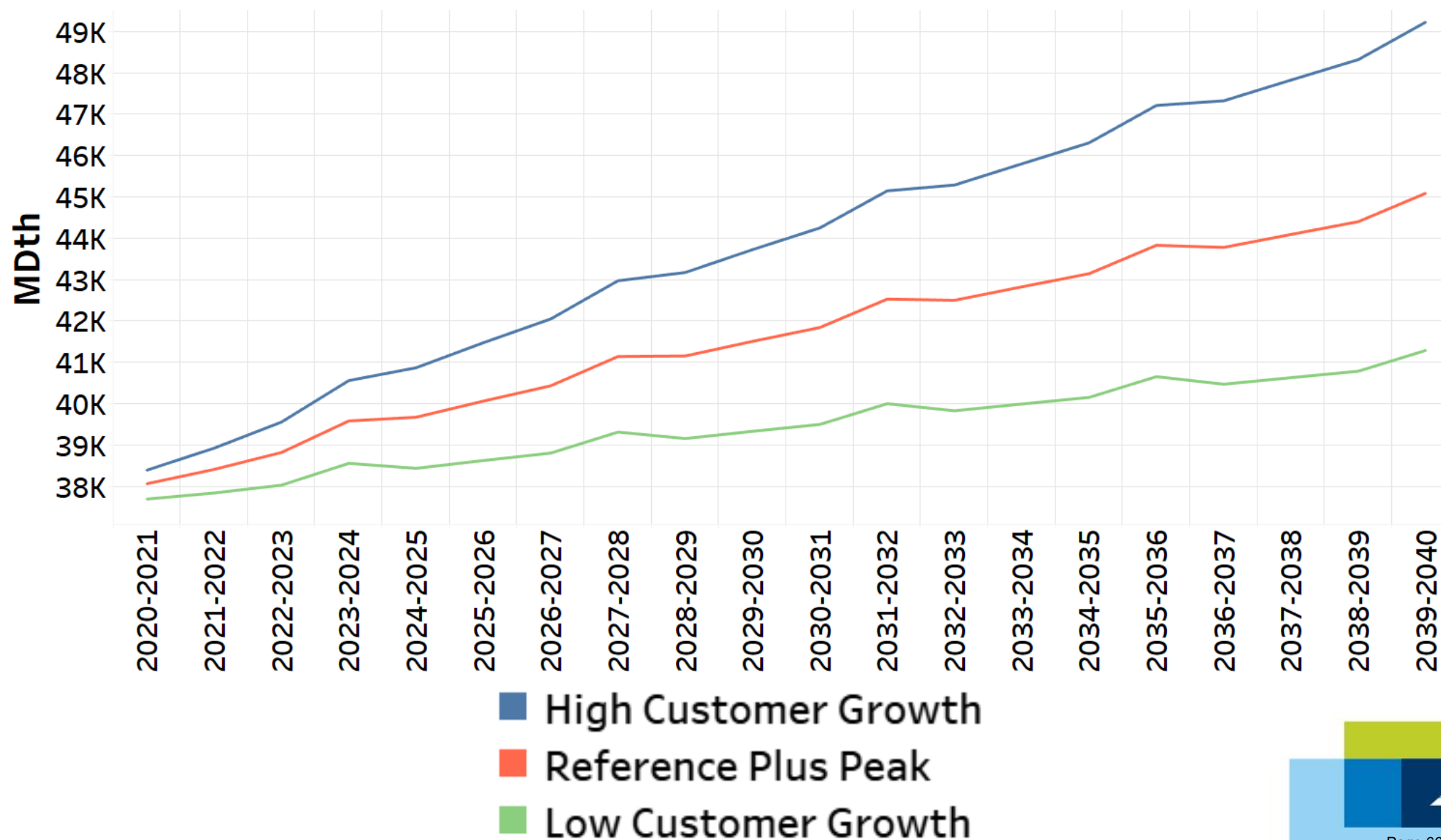

Demand Sensitivities: Price and Carbon Elasticities

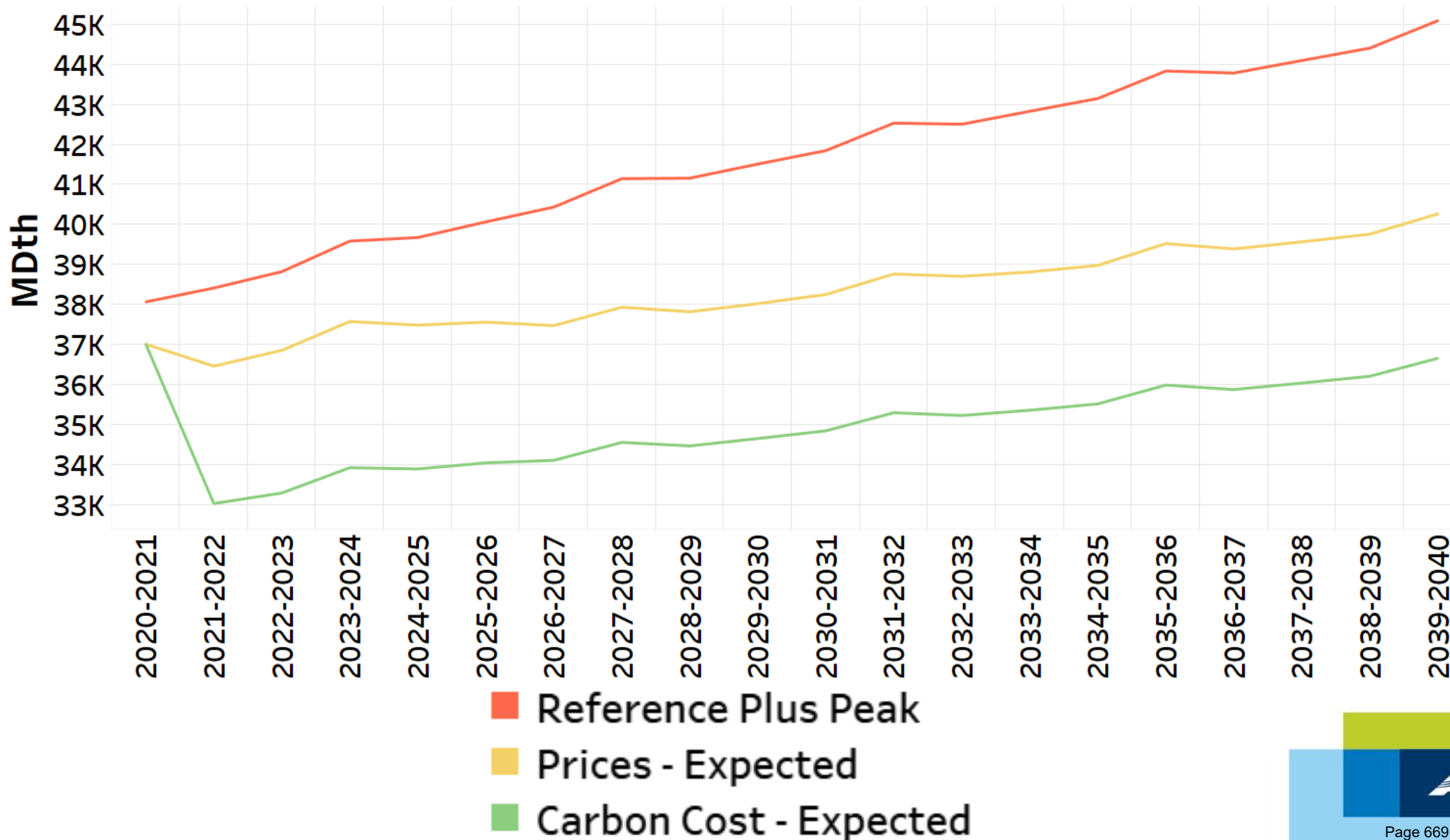

Demand Sensitivities: Price (with Elasticities)

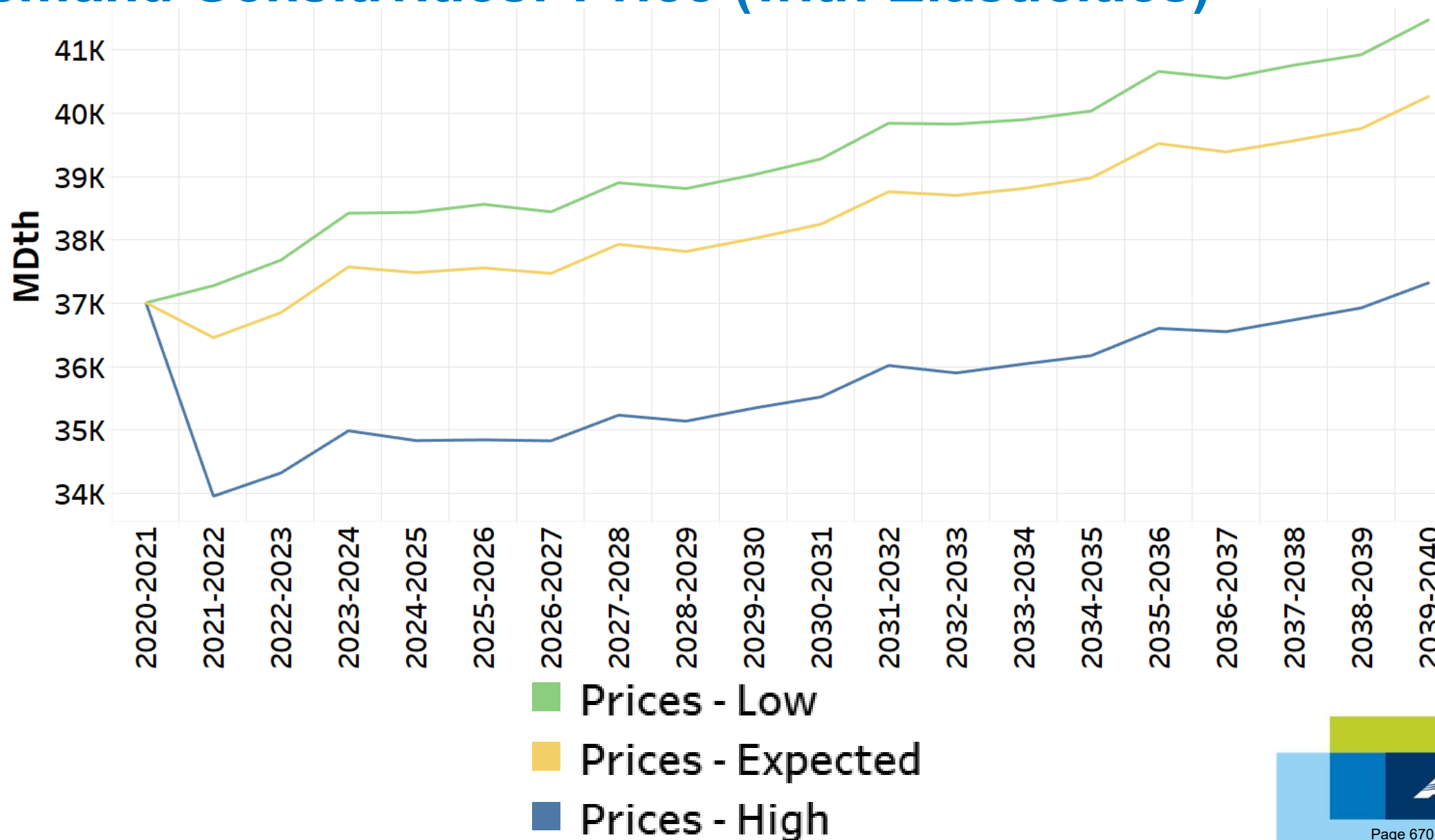

Demand Sensitivities: Carbon (with Elasticities)

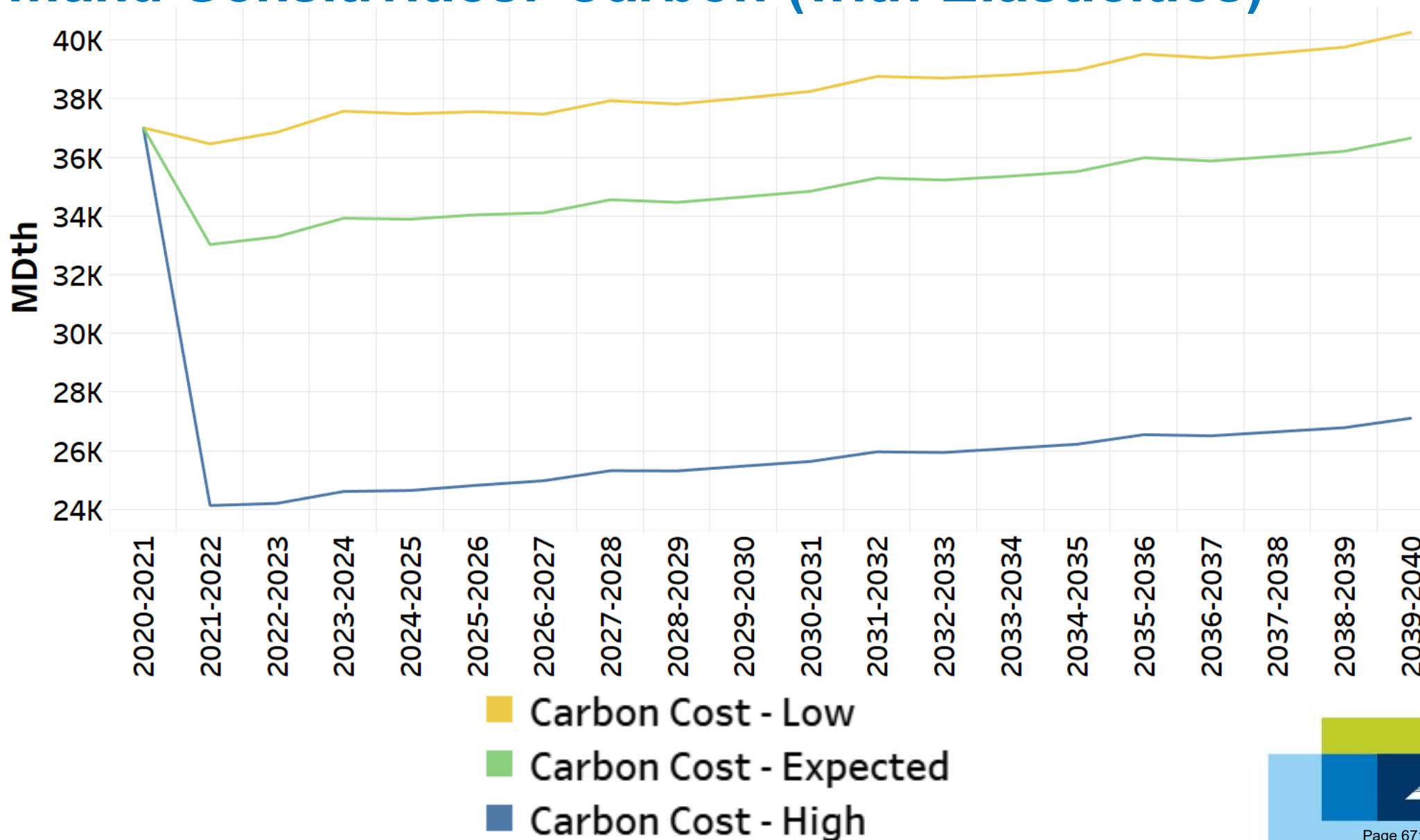

Demand Sensitivities: Upstream Emissions (with Elasticities)

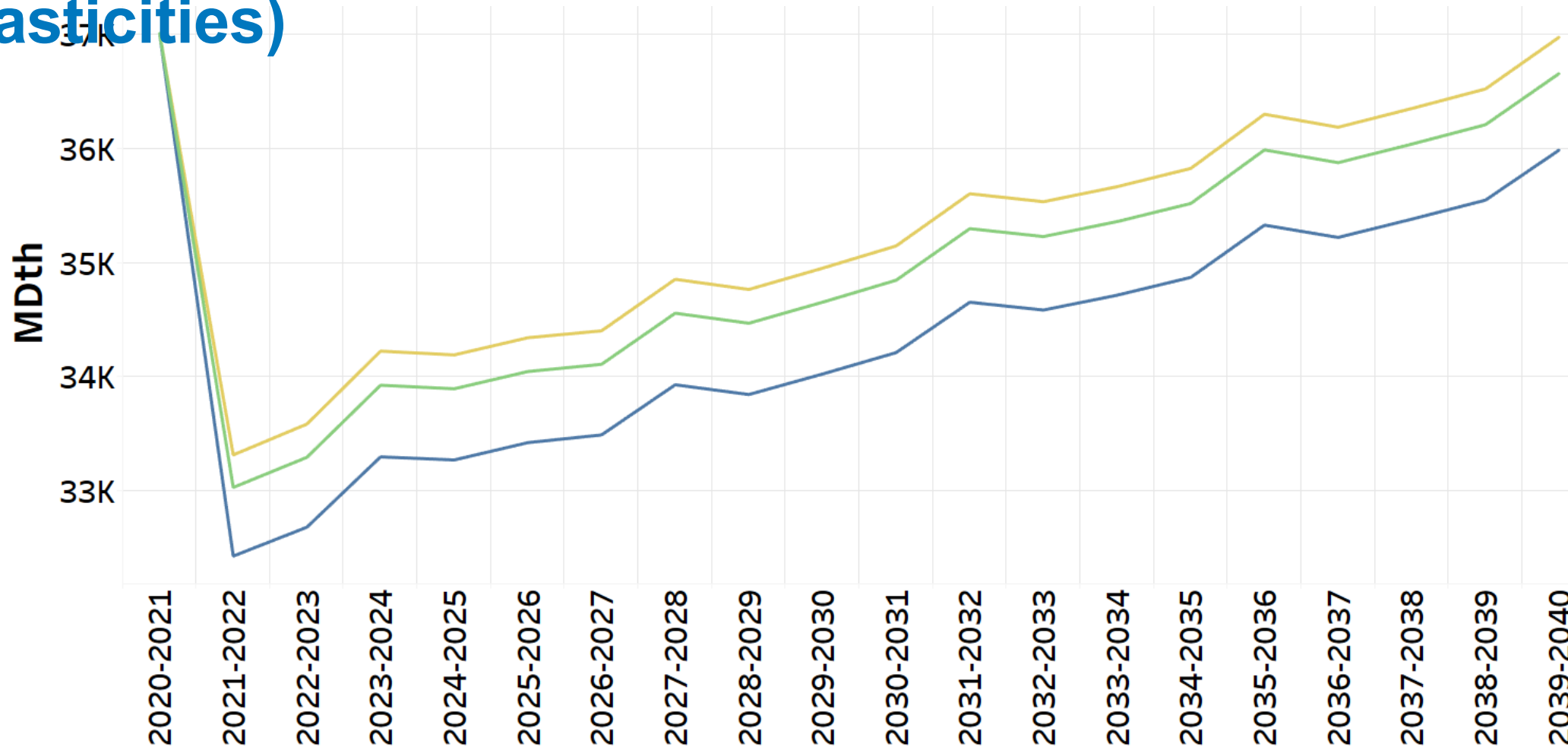

- No Upstream Emissions
- Carbon Cost - Expected
- Expected Upstream Emissions
- High Upstream Emissions



Demand Sensitivities: GWP (with Elasticities)

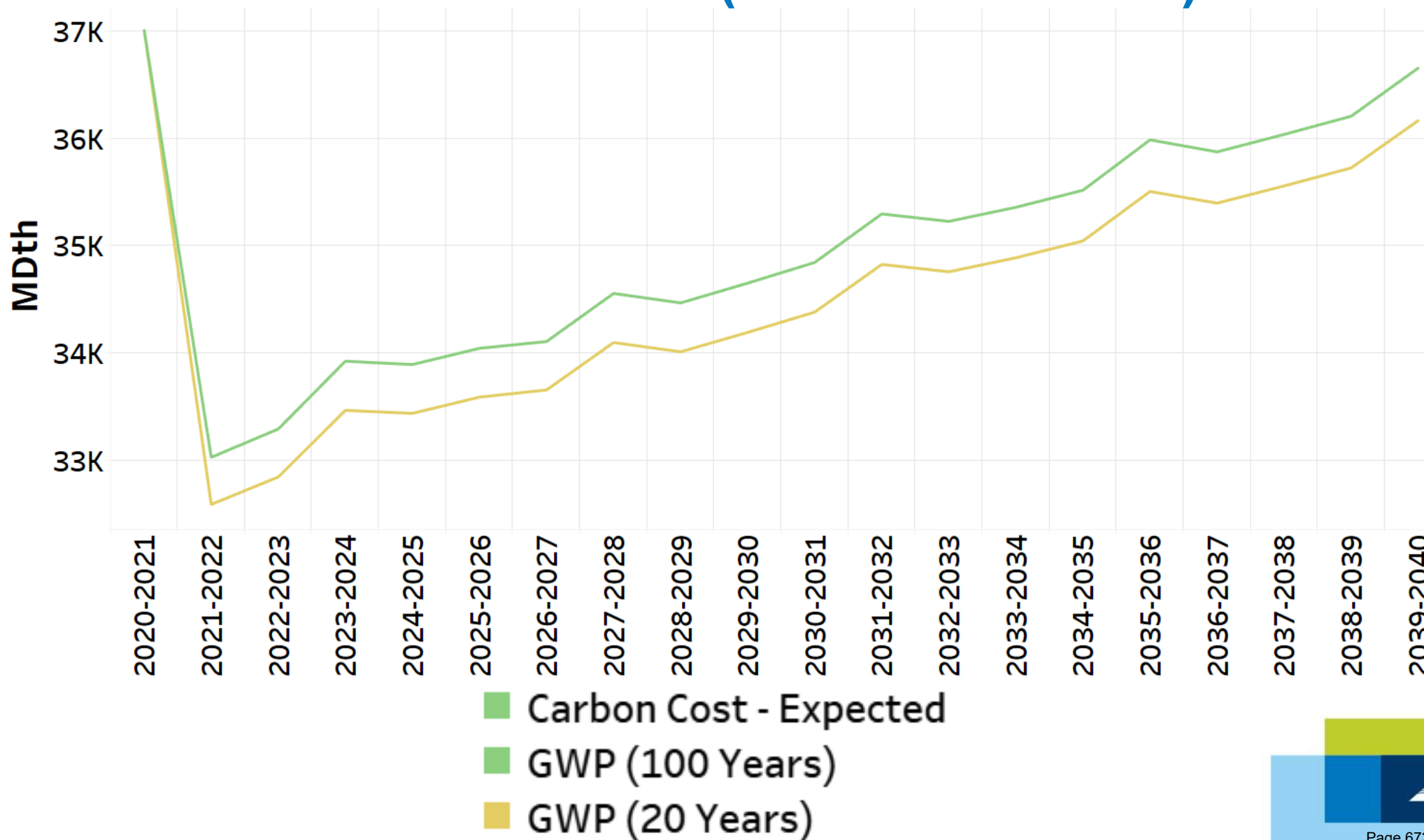

Demand (11/1/2020 – 10/31/2040)

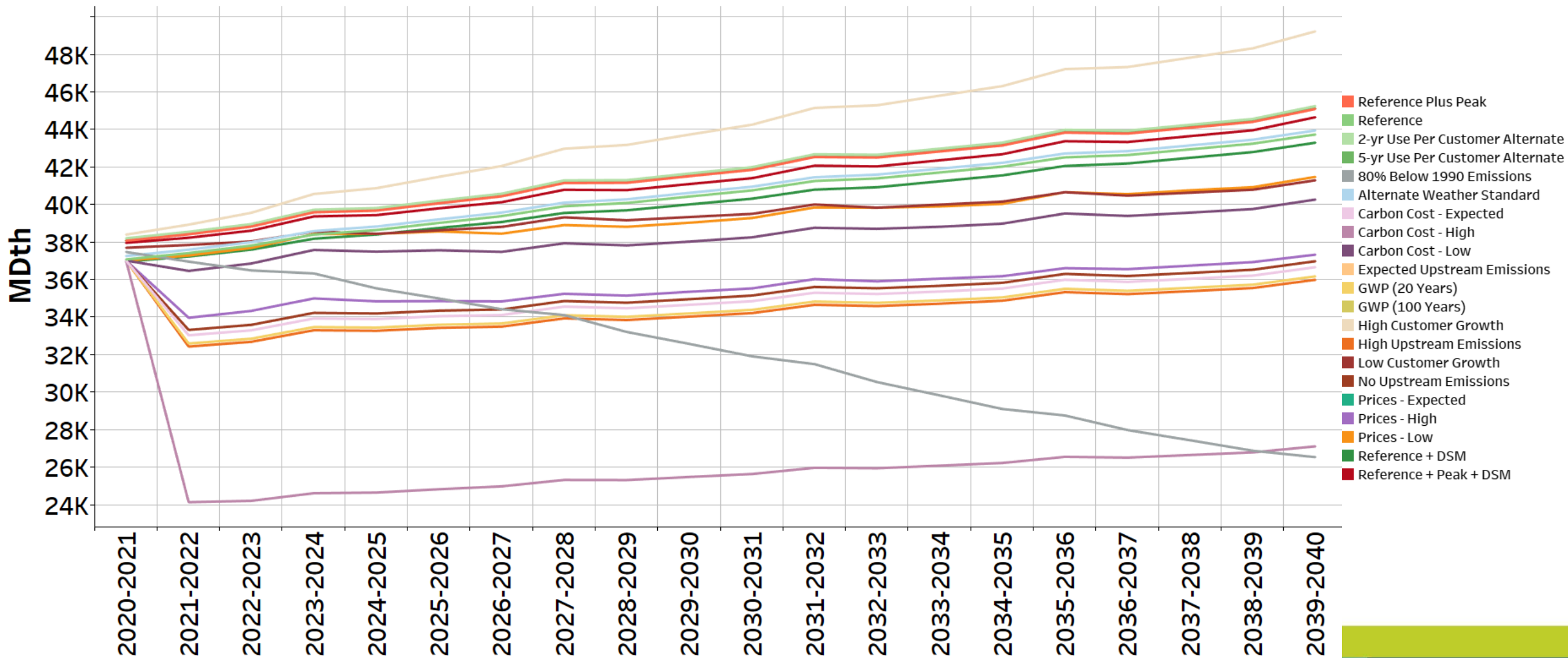

Sensitivities, Scenarios, Portfolios

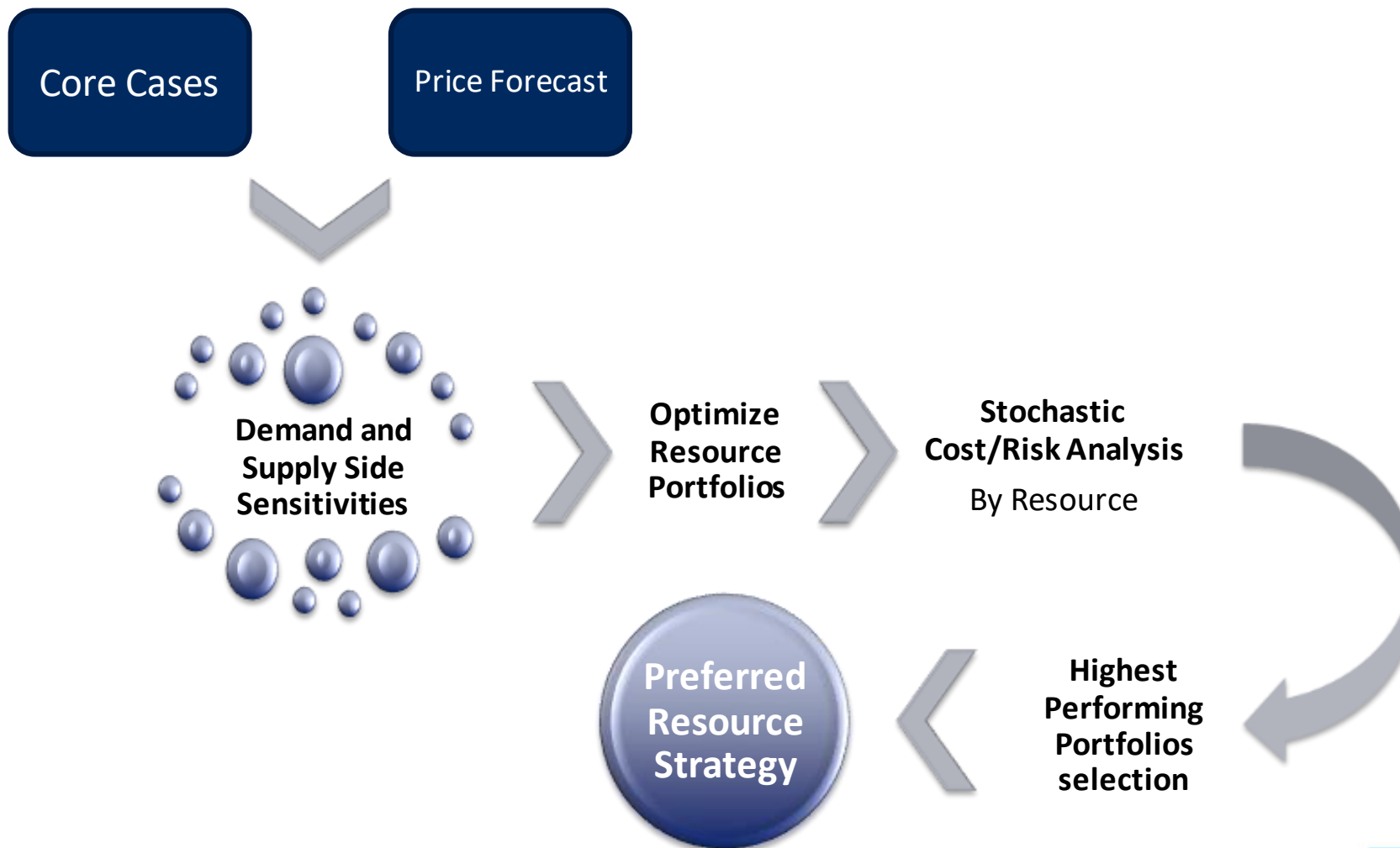

Proposed Scenarios

Proposed Scenarios INPUT ASSUMPTIONS	Expected Case	Average Case	Low Growth & High Prices	Carbon Reduction	High Growth & Low Prices
Customer Growth Rate	Reference Case Cust Growth Rates		Low Growth Rate	Reference Case Cust Growth Rates	High Growth Rate
Use per Customer	3 yr + Price Elasticity				
Demand Side Management	Expected Case CPA		High Prices DSM	Low Prices DSM	
Weather Planning Standard	99% probability of coldest in 30 years	20 year average	99% probability of coldest in 30 years		
GWP	100-Year GWP				
Prices Price curve	Expected		High	Low	
Carbon Legislation (\$/Metric Ton)	SCC @ 2.5% WA; Cap and Trade forecast - OR; NO Carbon adder in ID		Carbon Cost - High (SCC 95% at 3%)	SCC @ 2.5% WA; Cap and Trade forecast - OR; NO Carbon adder in ID	\$0
RESULTS					
First Gas Year Unserved Washington Idaho Medford Roseburg Klamath La Grande					
Scenario Summary					
	Most aggressive peak planning case utilizing Average Case assumptions as a starting point and layering in peak day 99% probability. The likelihood of occurrence is low.	Case most representative of our average (budget, PGA, rate case) planning criteria.	Stagnant growth assumptions in order to evaluate if a shortage does occur. Not likely to occur.	Reduction of the use of natural gas to 80% below 1990 targets in OR and WA by 2050. The case assumes the overall reduction is an average goal before applying figures like elasticity and DSM.	Aggressive growth assumptions in order to evaluate when our earliest resource shortage could occur. Not likely to occur.

*1,000 Draws per scenario will be run stochastically



2020 Natural Gas IRP Schedule

TAC 1: Wednesday, June 17, 2020: TAC meeting expectations, 2020 IRP process and schedule, energy efficiency update, actions from 2018 IRP, and a Winter of 2018-2019 review. Procurement Plan and Resource Optimization benefits. fugitive Emissions, Weather Analysis, Weather Planning Standard

TAC 2 (Dual Meeting with Power side): Thursday, August 6, 2020: Market Analysis, Price Forecasts, Cost Of Carbon, Environmental Policies

- Demand Results and Forecasting – August 18, 2020

TAC 3: Wednesday, September 30, 2020: Distribution, Avista's current supply-side resources overview, supply side resource options, renewable resources, Carbon cost, price elasticity, sensitivities and portfolio selection modeling.

TAC 4: Wednesday, November 18, 2020: CPA results from AEG & ETO, review assumptions and action items, final modeling results, portfolio risk analysis and 2020 Action Plan.



Natural Gas Integrated Resource Plan TAC #4

November 18, 2020

Agenda

1. CPA results from AEG (60 minutes) – Ken Walter
2. CPA results from ETO (60 minutes) – Spencer Moersfelder, Ted Light
3. Break (15 minutes)
4. Sendout Model (15 minutes) – Tom Pardee
5. Review assumptions (30 minutes) – Tom Pardee
6. Lunch break (60 minutes)
7. Final modeling results for Expected Case (60 minutes) – Tom Pardee
8. Final modeling results for Other Scenarios (60 minutes) – Tom Pardee
9. Action Plan and Next Steps (30 minutes) – Tom Pardee

2020 Natural Gas IRP Schedule

TAC 1: Wednesday, June 17, 2020: TAC meeting expectations, 2020 IRP process and schedule, energy efficiency update, actions from 2018 IRP, and a Winter of 2018-2019 review. Procurement Plan and Resource Optimization benefits. fugitive Emissions, Weather Analysis, Weather Planning Standard

TAC 2 (Dual Meeting with Power side): Thursday, August 6, 2020: Market Analysis, Price Forecasts, Cost Of Carbon, Environmental Policies

- Demand Results and Forecasting – August 18, 2020

TAC 3: Wednesday, September 30, 2020: Distribution, Avista's current supply-side resources overview, supply side resource options, renewable resources, Carbon cost, price elasticity, sensitivities and portfolio selection modeling.

TAC 4: Wednesday, November 18, 2020: CPA results from AEG & ETO, review assumptions and action items, final modeling results, portfolio risk analysis and 2020 Action Plan.



2020 CONSERVATION POTENTIAL ASSESSMENT – UPDATE

Prepared for the Avista Technical Advisory Committee

AVISTA 2020 NATURAL GAS CPA

CPA Methodology Overview

- Review of AEG Approach
- Levels of Potential
- Economic Screening and IRP Integration
- Retained enhancements from 2018 Action Plan

Summary of Results

- Summary of Potential
 - High level potential
 - Technical Achievable compared to Economic potential
- Comparison to previous CPA

ABOUT AEG

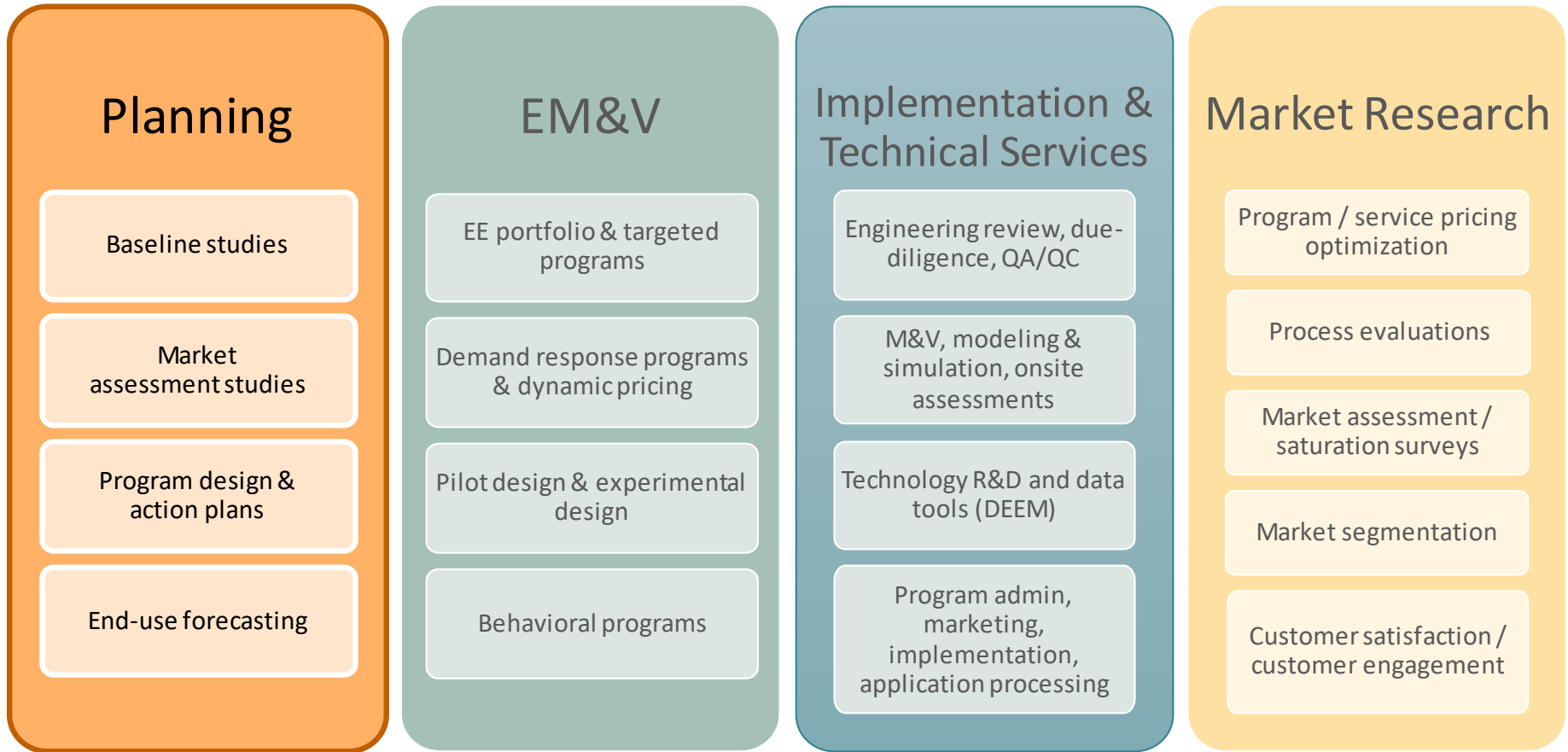

VISION DSM™ Platform

Full DSM lifecycle tracking & reporting

AEG EXPERIENCE IN PLANNING

Including Potential Studies and End-Use Forecasting

AEG has conducted more than 60 planning studies for more than 40 utilities / organizations in the past five years.

AEG has a team of 11 experienced Planning staff plus support from AEG's Technical Services and Program Evaluation groups

Northwest & Mountain:

- Avista*
- BPA*
- Cascade Natural Gas
- Chelan PUD
- Cheyenne LFP
- Colorado Electric*
- Cowlitz PUD*
- Inland P&L*
- Oregon Trail EC
- PacifiCorp*
- PNGC
- PGE*
- Seattle City Light*
- Tacoma Power*

Midwest:

- Ameren Illinois*
- Ameren Missouri*
- Citizens Energy
- Empire District Electric
- Indianapolis P&L*
- Indiana & Michigan Utilities
- Kansas City Power & Light
- MERC
- NIPSCO*
- Omaha Public Power District
- State of Michigan
- Vectren Energy*

Northeast & Mid Atlantic:

- Central Hudson G&E*
- Con Edison of NY*
- New Jersey BPU
- PECO Energy
- PSEG Long Island
- State of Maryland (BG&E, DelMarva, PEPCO, Potomac Edison, SMECO)

Southwest:

- HECO
- LADWP
- NV Energy*
- Public Service New Mexico*
- State of Hawaii
- State of New Mexico
- Xcel/SPS

South:

- OG&E
- Kentucky Power
- Southern Company (APC, GPC, Gulf Power, MPC)
- TVA

Regional & National:

- Midcontinent ISO*
- EEI/IEE*
- EPRI
- FERC

* Two or more studies

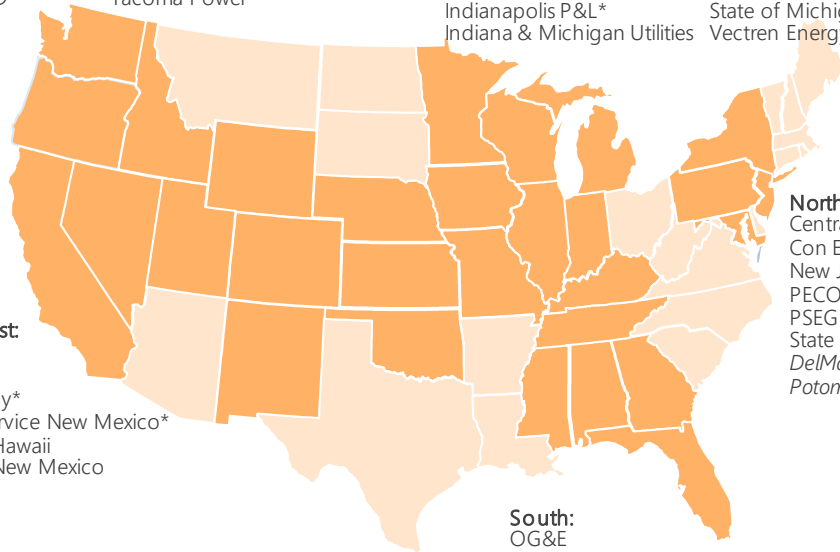



AEG CPA Methodology

CPA OBJECTIVES

The Avista Conservation Potential Assessment (CPA) supports the Company's regulatory filing and other demand-side management (DSM) planning efforts and initiatives.

The two primary research objectives for the 2020 CPA are:

- **Program Planning:** insights into the market for natural gas energy efficiency (EE) measures in Avista's Washington and Idaho service territories
 - For example, CPAs provide insight into changes to existing program measures as well as new measures to consider
- **IRP:** long-term forecast of future EE potential for use in the IRP
 - Economic Achievable Potential (EAP) for natural gas

AEG utilizes its comprehensive LoadMAP analytical models that are customized to Avista's service territory.

OVERVIEW OF AEG'S APPROACH

Overview – Natural Gas CPA

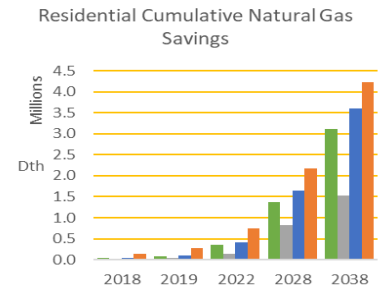
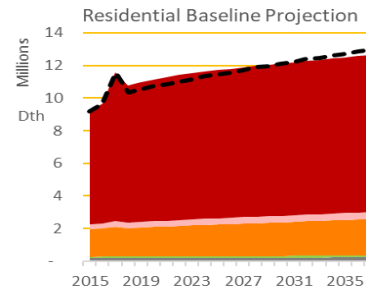
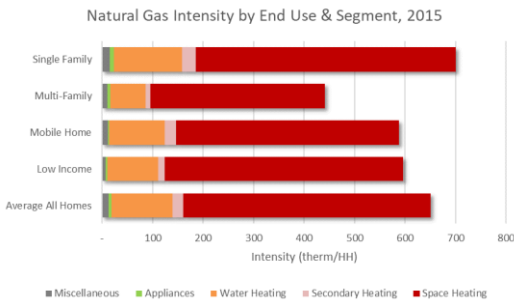
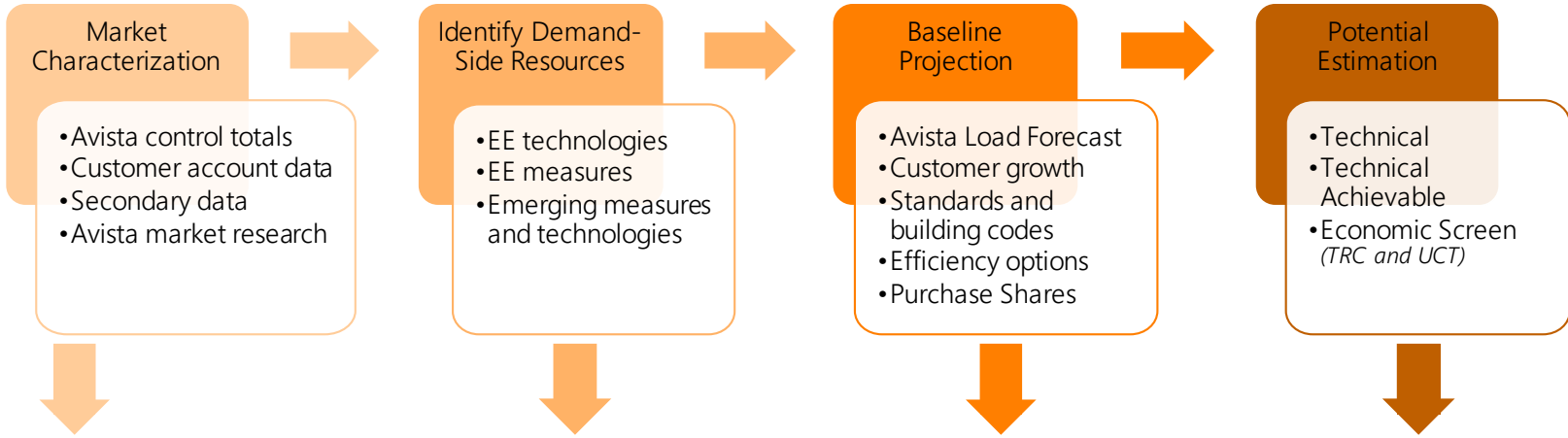

KEY SOURCES OF DATA

Prioritization of Avista Data

Data from Avista was prioritized when available, followed by regional data, and finally well-vetted national data.

Avista sources include:

- 2013 Residential GenPop Survey
- Forecast data and load research
- Recent-year accomplishments and plans

Regional sources include:

- NEEA studies (RBSA 2016, CBSA 2019, IFSA)
- RTF and Power Council methodologies, ramp rates, and measure assumptions

Additional sources include:

- U.S. DOE's Annual Energy Outlook
- Technical Reference Manuals and California DEER
- AEG Research

BASELINE PROJECTION

Overview

“How much energy would customers use in the future if Avista stopped running programs now and in the absence of naturally occurring efficiency?”

- The baseline projection answers this question

The baseline projection is an independent end-use forecast of natural gas consumption at the same level of detail as the market profile

The baseline projection:

Includes

- To the extent possible, the same forecast drivers used in the official load forecast, particularly customer growth, natural gas prices, normal weather, income growth, etc.
- Trends in appliance saturations, including distinctions for new construction.
- Efficiency options available for each technology, with share of purchases reflecting codes and standards (current and finalized future standards)
- Expected impact of appliance standards that are “on the books”
- Expected impact of building codes, as reflected in market profiles for new construction
- Market baselines when present in regional planning assumptions

Excludes

- Expected impact of naturally occurring efficiency (except market baselines)
- Impacts of current and future demand-side management programs

LEVELS OF POTENTIAL

We estimate three levels of potential. These are standard practice for CPAs in the Northwest:

- **Technical:** everyone chooses the most efficient option when equipment fails regardless of cost
- **Achievable Technical** is a subset of technical that accounts for achievable participation within utility programs as well as non-utility mechanisms, such as regional initiatives and market transformation
- **Achievable Economic** is a subset of achievable technical potential that includes only cost-effective measures. Tests considered within this study include UCT, and TRC.

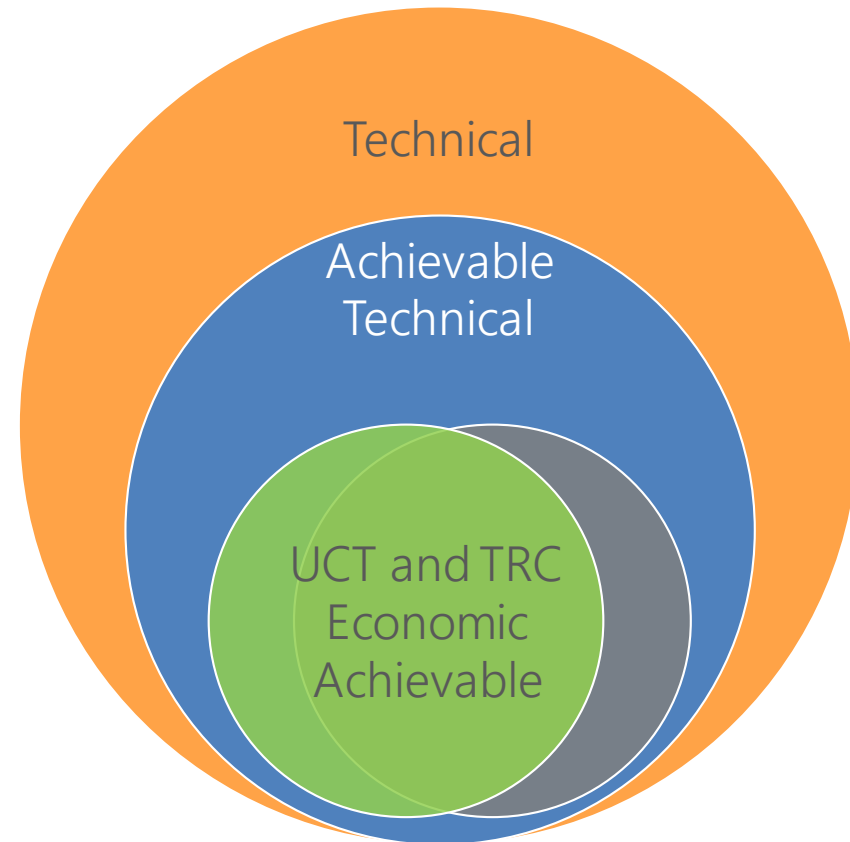

ECONOMIC SCREENING

Two Cost-Effectiveness Tests

In assessing cost-effective, achievable potential within Avista’s Washington and Idaho territories, AEG utilized two cost tests:

- **Utility Cost Test (UCT):** Assesses cost-effectiveness from a utility or program administrator’s perspective.
- **Total Resource Cost Test (TRC):** Assesses cost-effectiveness from the utility’s and participant’s perspectives. Includes non-energy impacts if they can be quantified and monetized.

Component	UCT	TRC
Avoided Energy	Benefit	Benefit
Non-Energy Benefits*		Benefit
Incremental Cost		Cost
Incentive	Cost	
Administrative Cost	Cost	Cost
Non-Energy Costs* (e.g. O&M)		Cost

*Council methodology includes monetized impacts on other fuels within these categories

ENHANCEMENTS RETAINED FROM 2018 CPA

- The Measure Assumptions appendix is again available, containing UES data and other key assumptions and their sources
- **Fully Balanced TRC.** Using the same process developed in the 2018 CPA, the balanced TRC test includes an expanded scope of documentable and quantifiable impacts, including:
 1. 10% Conservation Credit in Washington
 2. Quantified and monetized non-energy impacts (e.g. water, detergent, wood)
 3. Projected cost of carbon in Washington
 4. Heating calibration credit for secondary fuels (12% for space heating, 6% for secondary heating)
 5. Electric benefits for applicable measures (e.g. cooling savings for smart thermostats, lighting and refrigeration savings for retrocommissioning)

GAS ENERGY EFFICIENCY POTENTIAL

Potential Summary –WA & ID All Sectors

Projections indicate that gas savings of 1.5% of baseline consumption per year are Technically Achievable, and 0.8% per year is cost effective under the UCT test.

- TAP savings are 643,198 Dth in 2022, and 4,906,228 Dth in 2030
- UCT savings are 261,833 Dth in 2022 and 2,124,189 Dth in 2030
- Across the study period, ~46% of TAP savings are UCT cost-effective

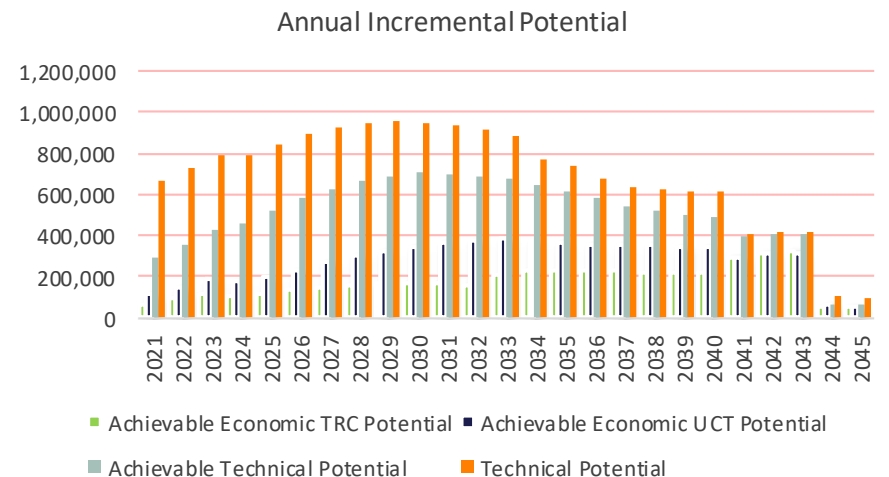
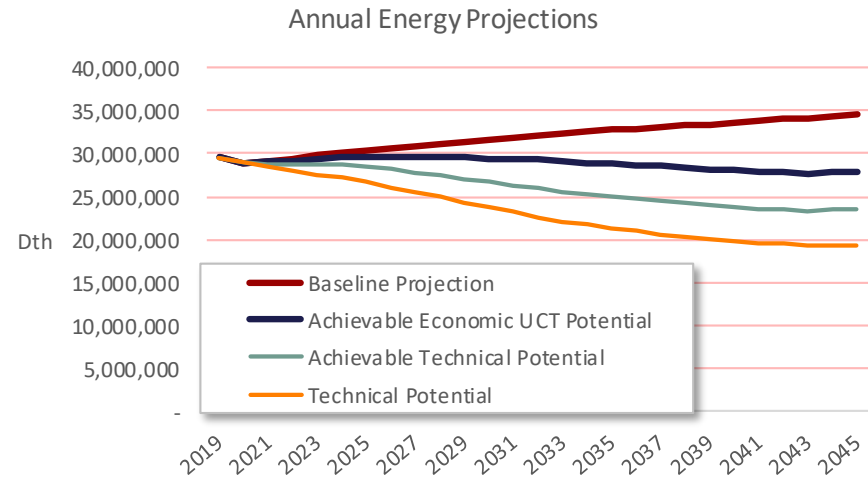

GAS EE POTENTIAL, CONTINUED

Potential Summary – WA & ID, All Sectors

Cumulative UCT Gas Savings (Dth) by Sector

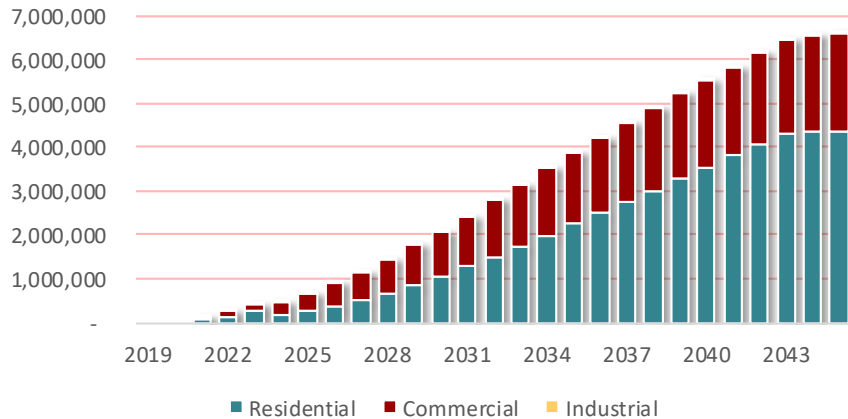

Cumulative Gas Savings, Selected Years

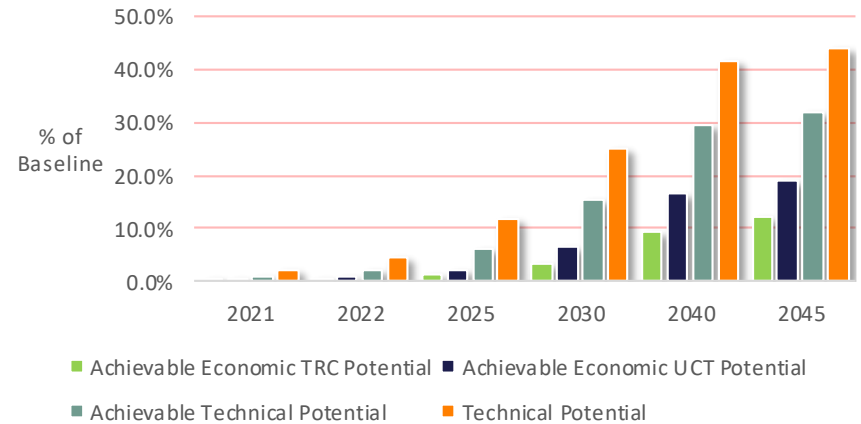

Summary of Energy Savings (Dth), Selected Years	2021	2022	2025	2030	2040	2045
Reference Baseline	29,137,671	29,434,469	30,325,189	31,617,083	33,626,695	34,510,725
Cumulative Savings (Dth)						
Achievable Economic TRC Potential	68,091	163,156	364,805	1,125,806	3,188,178	4,257,057
Achievable Economic UCT Potential	111,637	261,833	686,706	2,124,189	5,585,922	6,625,682
Achievable Technical Potential	290,015	643,198	1,879,807	4,906,228	9,853,874	10,970,898
Technical Potential	662,737	1,387,924	3,587,536	7,862,508	13,922,189	15,068,864
Energy Savings (% of Baseline)						
Achievable Economic TRC Potential	0.2%	0.6%	1.2%	3.6%	9.5%	12.3%
Achievable Economic UCT Potential	0.4%	0.9%	2.3%	6.7%	16.6%	19.2%
Achievable Technical Potential	1.0%	2.2%	6.2%	15.5%	29.3%	31.8%
Technical Potential	2.3%	4.7%	11.8%	24.9%	41.4%	43.7%
Incremental Savings (Dth)						
Achievable Economic TRC Potential	68,091	95,046	117,484	165,797	218,288	49,635
Achievable Economic UCT Potential	111,637	150,478	202,477	345,896	343,741	56,935
Achievable Technical Potential	290,015	355,639	522,562	701,742	483,964	58,801
Technical Potential	662,737	730,524	845,047	950,617	611,563	98,433

GAS EE TOP MEASURES

Achievable Economic UCT Potential

Rank	Measure / Technology (Ranked by 1st year potential)	Achievable Economic UCT Potential (Dth)				% of Total
		2021	2022	2023	2030	
1	Residential - Furnace	35,602	81,473	134,334	136,211	6.4%
2	Residential - Gas Furnace - Maintenance	13,403	30,912	48,232	177,842	8.4%
3	Commercial - Water Heater	8,854	25,070	46,662	292,125	13.8%
4	Commercial - Space Heating - Heat Recovery Ventilator	7,569	15,162	22,499	65,615	3.1%
5	Commercial - Boiler	6,643	17,112	30,155	131,730	6.2%
6	Residential - Insulation - Ceiling, Installation	5,253	11,641	19,390	99,329	4.7%
7	Residential - ENERGY STAR Connected Thermostat	4,435	9,925	16,719	114,399	5.4%
8	Commercial - HVAC - Duct Repair and Sealing	3,777	7,461	11,046	33,252	1.6%
9	Commercial - Insulation - Wall Cavity	3,337	9,043	17,710	123,408	5.8%
10	Residential - Water Heater	2,954	9,266	19,112	162,884	7.7%
11	Industrial - Process Heat Recovery	2,849	5,670	8,461	21,943	1.0%
12	Commercial - Gas Boiler - Insulate Steam Lines/Condensate Tank	2,517	4,965	7,337	21,733	1.0%
13	Commercial - Insulation - Roof/Ceiling	2,507	6,823	13,348	89,849	4.2%
14	Commercial - Water Heater - Central Controls	1,901	3,766	5,585	13,155	0.6%
15	Commercial - Gas Boiler - Hot Water Reset	1,822	4,002	6,598	30,638	1.4%
16	Commercial - Gas Boiler - High Turndown	1,230	2,424	3,578	8,452	0.4%
17	Commercial - Fryer	1,210	2,946	5,199	29,424	1.4%
18	Commercial - Building Automation System	590	1,735	3,703	61,280	2.9%
19	Commercial - Water Heater - Faucet Aerator	581	1,269	2,079	9,046	0.4%
20	Commercial - Kitchen Hood - DCV/MUA	529	1,055	1,577	5,057	0.2%
Total of Top 20 Measures		107,565	251,718	423,324	1,627,371	76.6%
Total Cumulative Savings		111,637	261,833	445,437	2,124,189	100.0%

GAS EE TOP MEASURES

UCT & TRC Potential vs Technical Achievable

Rank	Measure / Technology (Ranked by 10-year TAP)	2030 Savings (Dth)			% of TAP	
		TAP	UCT	TRC	UCT	TRC
1	Residential - Windows - High Efficiency	670,667	905	0	0.1%	0.0%
2	Residential - Combined Boiler + DHW System (Storage Tank)	410,862	0	0	0.0%	0.0%
3	Residential - Combined Boiler + DHW System (Tankless)	338,983	0	0	0.0%	0.0%
4	Commercial - Water Heater	292,125	292,125	292,125	100.0%	100.0%
5	Residential - ENERGY STAR Homes	198,515	198,833	0	100.2%	0.0%
6	Residential - Gas Furnace - Maintenance	191,846	177,842	0	92.7%	0.0%
7	Residential - Water Heater	163,124	162,884	0	99.9%	0.0%
8	Residential - Insulation - Wall Cavity, Installation	162,690	8,840	0	5.4%	0.0%
9	Residential - Insulation - Ceiling, Installation	145,717	99,329	0	68.2%	0.0%
10	Residential - Furnace	136,211	136,211	136,211	100.0%	100.0%
11	Residential - ENERGY STAR Connected Thermostat	136,197	114,399	0	84.0%	0.0%
12	Commercial - Boiler	131,730	131,730	131,730	100.0%	100.0%
13	Residential - Insulation - Floor/Crawlspace	128,866	56,643	0	44.0%	0.0%
14	Commercial - Insulation - Wall Cavity	123,131	123,408	115,763	100.2%	94.0%
15	Commercial - Water Heater - Solar System	112,885	0	0	0.0%	0.0%
16	Residential - Windows - Low-e Storm Addition	108,983	0	121,262	0.0%	111.3%
17	Commercial - Insulation - Roof/Ceiling	97,447	89,849	31,527	92.2%	32.4%
18	Residential - Insulation - Ceiling, Upgrade	83,492	0	0	0.0%	0.0%
19	Residential - Insulation - Basement Sidewall	81,620	0	0	0.0%	0.0%
20	Commercial - Building Automation System	74,305	61,280	0	82.5%	0.0%
Total of Top 20 Measures		3,789,395	1,654,278	828,619		
Total Cumulative Savings		4,906,228	2,124,189	1,125,806	43.3%	22.9%

ACHIEVABLE POTENTIAL COMPARISON

Comparison with Prior Potential Study (2021-2038 TAP)

- The previous CPA included potential for 2018-2020, which is removed here
- For the 2021-2038 period, the current study shows quite a bit more **Technical Achievable** potential
- However, **UCT Cost Effective** potential is lower for this period.
 - Largest drop is in Residential water heating, due to a combination of factors:
 - Lower Water Heater unit savings
 - Removal or reduction in WA of HB-1444 affected water saving measures
 - New potential from measures like combination DHW+Boiler systems is expensive

Sector (All States)	End Use	2038 TAP Savings (Dth)		Diff.
		Prior CPA	Current Study	
Residential	Space Heating	2,879,487	4,019,918	1,140,431
	Secondary Heating	62,068	37,249	-24,819
	Water Heating	2,264,651	2,382,341	117,690
	Appliances	3,455	21,880	18,425
	Miscellaneous	2,682	3,172	490
Commercial	Space Heating	1,328,855	1,523,386	194,530
	Water Heating	268,621	903,545	634,924
	Food Preparation	136,388	139,204	2,816
	Miscellaneous	51	173	122
Industrial	Space Heating	7,145	8,125	980
	Process	15,435	40,310	24,875
	Miscellaneous	369	0	-369
Grant Total		6,969,208	9,079,303	2,110,095

Sector (All States)	End Use	2038 UCT Savings (Dth)		Diff.
		Prior CPA	Current Study	
Residential	Space Heating	2,274,729	2,071,662	-203,067
	Secondary Heating	0	0	0
	Water Heating	2,223,975	943,071	-1,280,904
	Appliances	1,258	0	-1,258
	Miscellaneous	0	0	0
Commercial	Space Heating	1,131,121	1,088,143	-42,978
	Water Heating	135,582	638,616	503,033
	Food Preparation	136,388	139,204	2,816
	Miscellaneous	45	148	103
Industrial	Space Heating	1,747	6,906	5,159
	Process	14,367	34,395	20,028
	Miscellaneous	369	0	-369
Grant Total		5,919,582	4,922,145	-997,437

ACHIEVABLE POTENTIAL

2030 Savings (TAP) by UCT Cost Bundle – WA + ID All Sectors

2030 TAP	
UCT \$/Therm	Savings (Dth)
\$0.00 - \$0.10	616,956
\$0.10 - \$0.20	213,315
\$0.20 - \$0.30	371,273
\$0.30 - \$0.40	146,027
\$0.40 - \$0.50	431,922
\$0.50 - \$0.60	219,860
\$0.60 - \$0.70	132,429
\$0.70 - \$0.80	222,526
\$0.80 - \$0.90	184,609
\$0.90 - \$1.00	55,730
\$1.00 - \$1.10	94,636
\$1.10 - \$1.20	91,213
\$1.20 - \$1.30	140,536
\$1.30 - \$1.40	215,089
\$1.40 - \$1.50	111,421
\$1.50 - \$1.60	109,370
\$1.60 - \$1.70	228,011
\$1.70 - \$1.80	158,836
\$1.80 - \$1.90	625,317
\$1.90 - \$2.00	54,020
\$2 or more	483,133

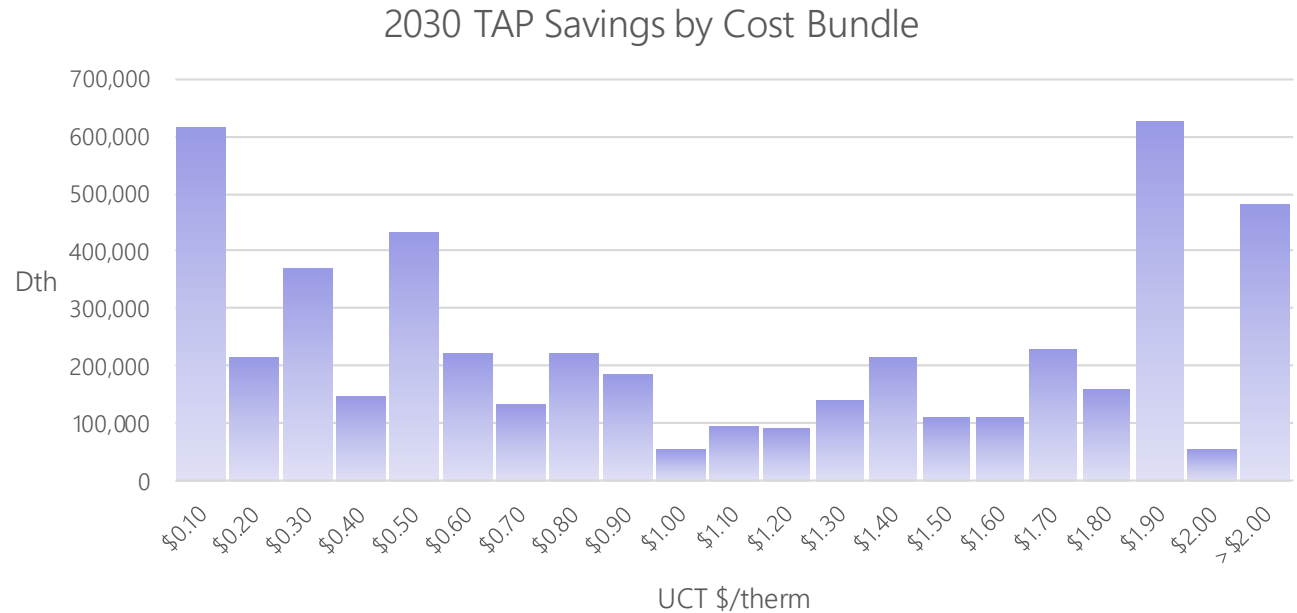



THANK YOU!

Ingrid Rohmund, Sr. Vice President, Consulting
irohmund@appliedenergygroup.com

Ken Walter, Project Manager
kwalter@appliedenergygroup.com

Kelly Marrin, Managing Director
kmarrin@appliedenergygroup.com

Tommy Williams, Lead Analyst
twilliams@appliedenergygroup.com



Energy Trust of Oregon

Energy Efficiency Resource Assessment Study

November 18, 2020



Agenda

- About Energy Trust
- 2019 Achieved Savings
- Resource Assessment Overview and Background
- Methodology
- Results
- Questions/Discussion

About us

Independent
nonprofit

Serving 1.6 million customers of
Portland General Electric,
Pacific Power, NW Natural,
Cascade Natural Gas and Avista

Providing access
to affordable
energy

Generating
homegrown,
renewable power

Building a
stronger Oregon
and SW
Washington

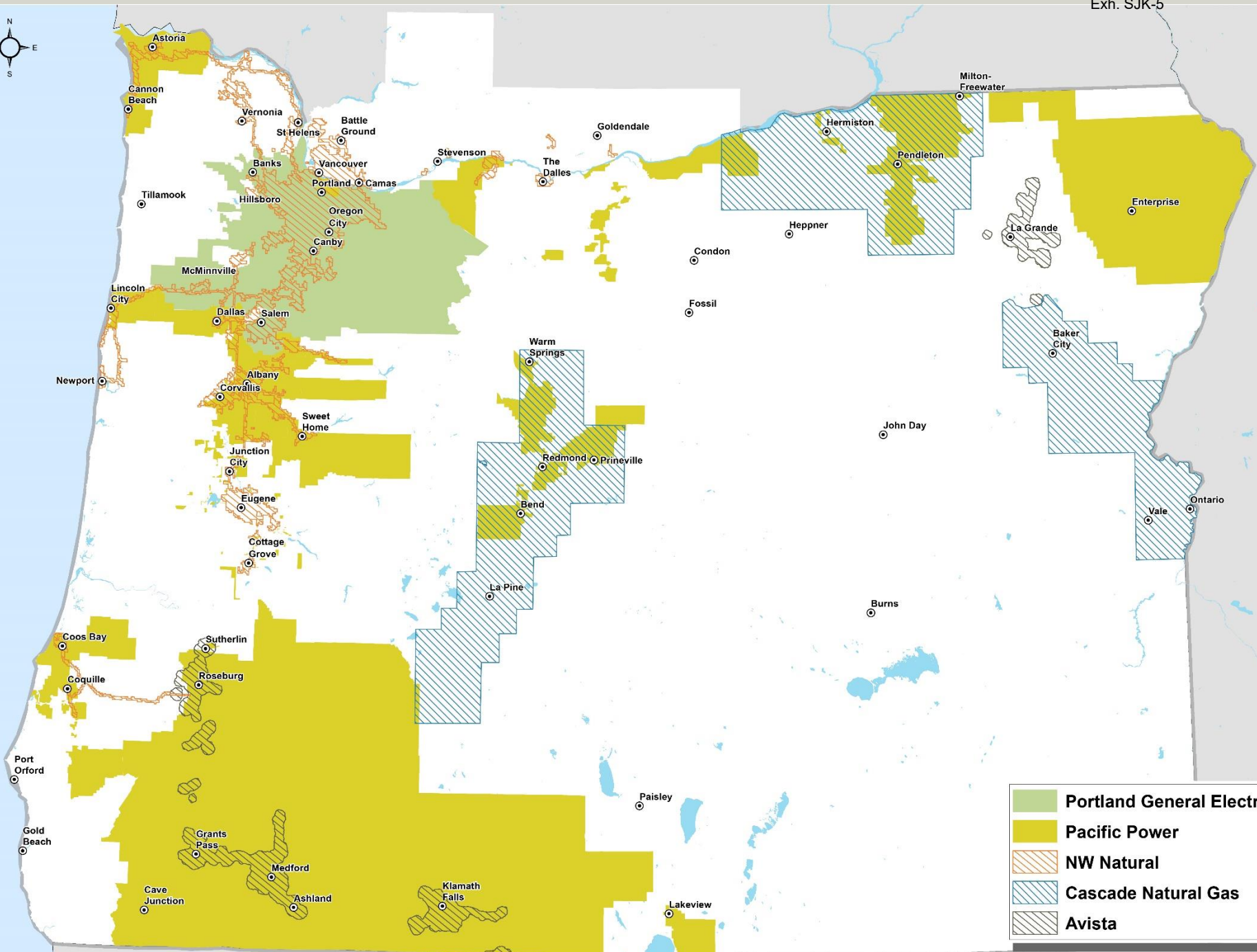

15 years of affordable energy

From Energy Trust's investment of \$1.5 billion in utility customer funds:

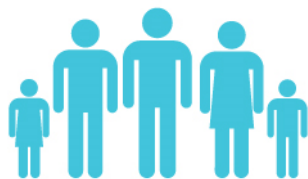

Nearly 660,000 sites

transformed into energy efficient, healthy, comfortable and productive homes and businesses



10,000 clean energy systems generating renewable power from the sun, wind, water, geothermal heat and biopower



\$6.9 billion in savings over time on participant utility bills from their energy-efficiency and solar investments



20 million tons of carbon dioxide emissions kept out of our air, equal to removing 3.5 million cars from our roads for a year

A clean energy power plant

607 average megawatts saved

121 aMW generated

52 million annual therms saved

Enough energy to power **564,000** homes
and heat **100,000** homes for a year

Avoided **20** million tons of carbon dioxide

Energy Trust's 2019 Achievements for Avista

Energy Trust Savings Achievements – 2019

- Energy Trust began serving Avista customers in Oregon in 2016.
- Overall achieved 107% of goal
 - Goal 360k Therms
 - Achieved 384k Therms
- Anticipate continued success as we solidify trade ally and customers relationships.

2019 Energy Trust Goals to Actuals

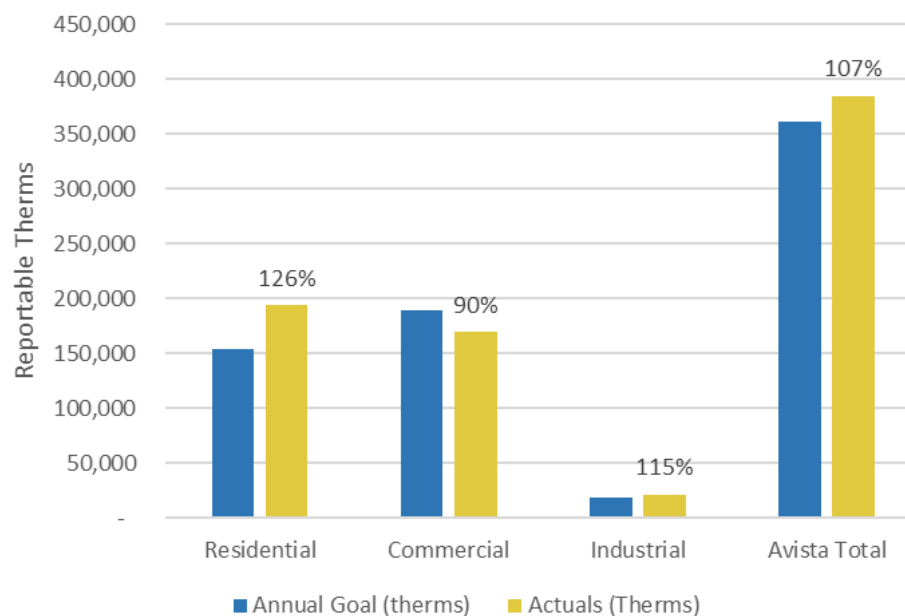

Energy Trust achieved 107% of goal in Avista service territory

Resource Assessment: Purpose, Overview and Background

Resource Assessment (RA) Purpose

- Provides estimates of energy efficiency potential that will result in a reduction of load on Avista's system for use in Avista's Integrated Resource Plan (IRP).
- The purpose is to help Avista strategically plan future investment in both supply side and demand side resources.





Resource Assessment Overview

- What is a resource assessment?
 - Model that provides an estimate of energy efficiency resource potential achievable over a 20-year period
 - 'Bottom-up' approach to estimate potential starting at the measure level and scaling to a service territory
- Energy Trust uses a model in *Analytica* that was developed by Navigant Consulting
 - The *Analytica* model calculates Technical, Achievable and Cost-Effective Achievable Energy Efficiency Potential.
 - Final program/IRP targets are established via ramp rates that are applied outside of the model.
- Data inputs and assumptions in the model are updated in conjunction with IRP about every two years.

Additional Resource Assessment Background

- Informs utility IRP work & Energy Trust strategic and program planning.
- Does not specify mechanism of savings acquisition (e.g. programs, market transformation, codes & standards)
- Does not dictate source or measure mix of annual energy savings acquired by programs
- Does not set incentive levels



20-Year Forecast Methodology

Forecasted Potential Types

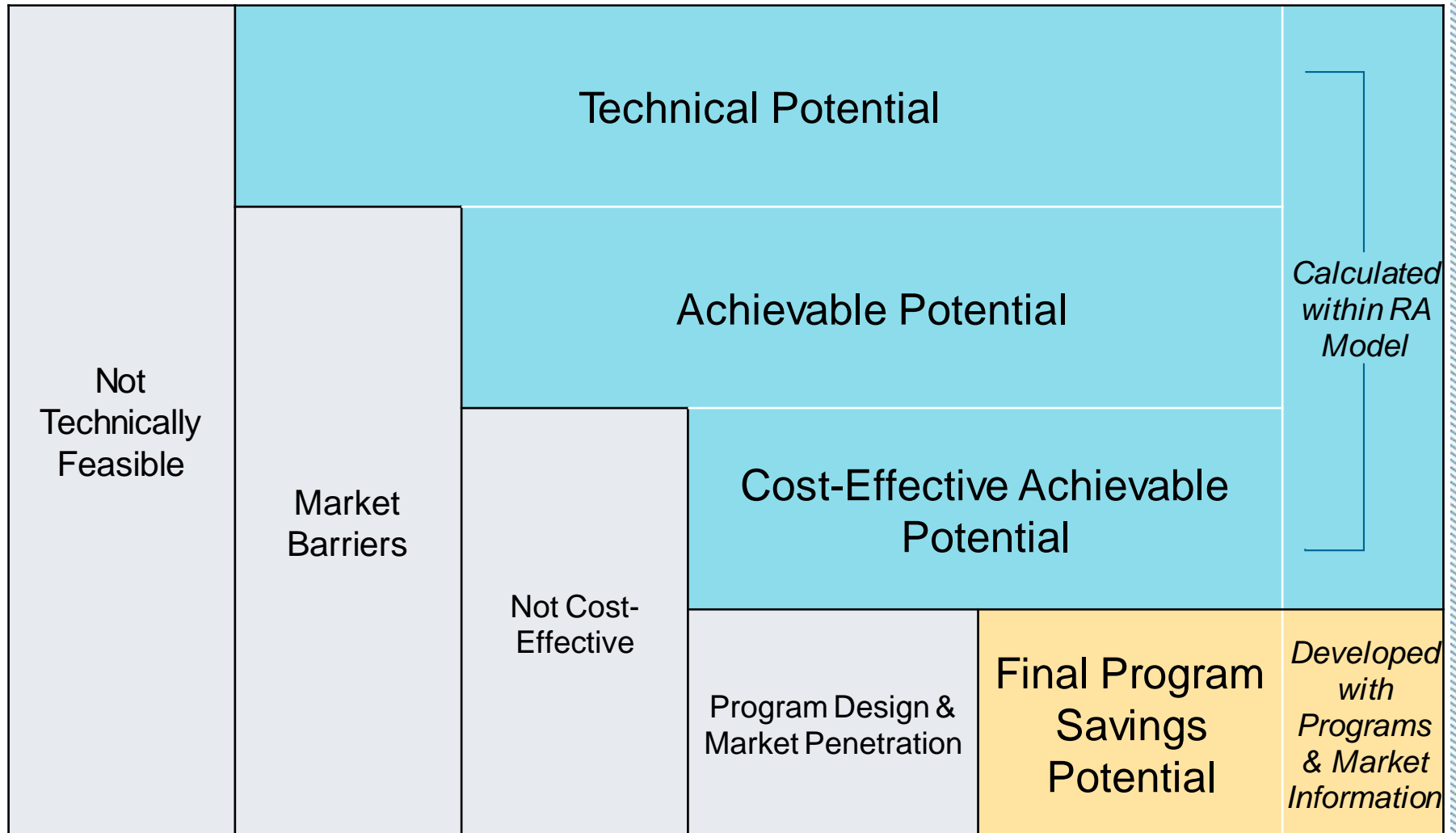

20-Year IRP EE Forecast Flow Chart

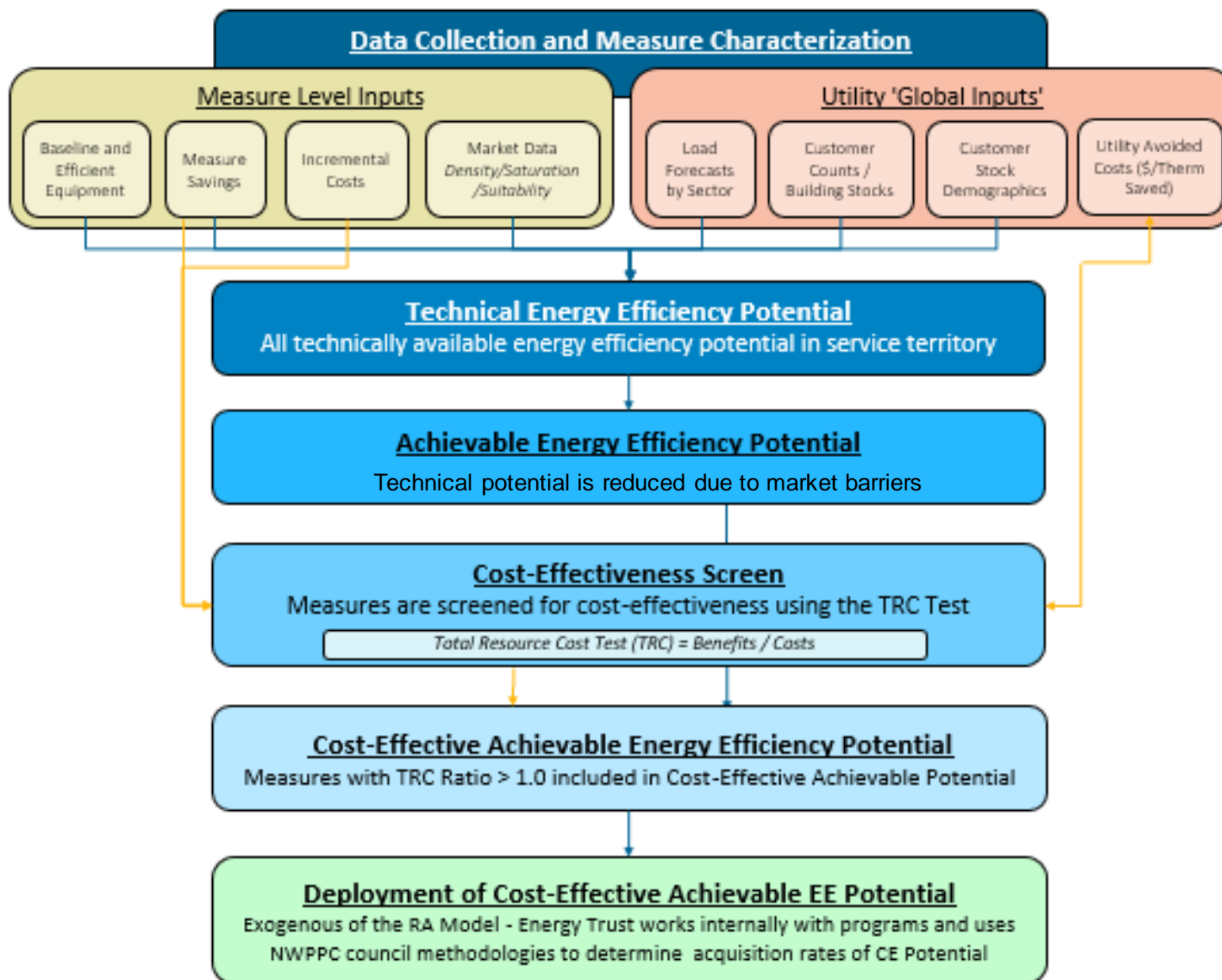

RA Model inputs

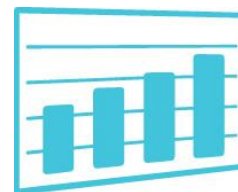

Measure Inputs

Measure Definition:

- Baseline & Efficient equipment
- Applicable customer segments
- Installation type*
- Measure Life

Measure Savings

Measure Cost

- Incremental cost for lost opportunity measures
- Full cost for retrofit measures

Market Data

- Density
- Saturation of baseline equipment
- Technical suitability

Utility Inputs

Customer and Load Forecasts

Used to scale measure level savings to a service territory

- Residential Stock: Count of homes
- Commercial Stock: Floor Area
- Industrial Stock: Customer load

Avoided Costs

Customer Stock Demographics:

- Heating fuel splits
- Water heat fuel splits

**Retrofit, Replace on Burnout, or New Construction*

Model Updates

- The RA Model is a 'living' model and Energy Trust makes continuous improvements to it.
- Measure updates, new measures and new emerging technologies updated in model
- Alignment with high-level NW Power Council Power Plan deployment methodologies to obtain cost-effective achievable savings within market sectors and replacement types.



Example Measure: Residential Gas Tank Water Heater (>0.70 EF)

Key Measure Inputs:



- Baseline: 0.60 EF gas water heater
- Replacement Type: Replacement on Burnout / New
- Measure Incremental Cost: \$218
- Conventional (not emerging, no risk adjustment)
- Lifetime: 13 years
- Savings: 31.6 therms (annual)
- Non-Energy Benefits: \$5.34 per year
- Customer Segments: SF, MF, MH
- Density, Saturation, Suitability
- Competing Measures: All efficient gas water heaters

Incremental Measure Savings Approach (Competition group: Gas water heaters)

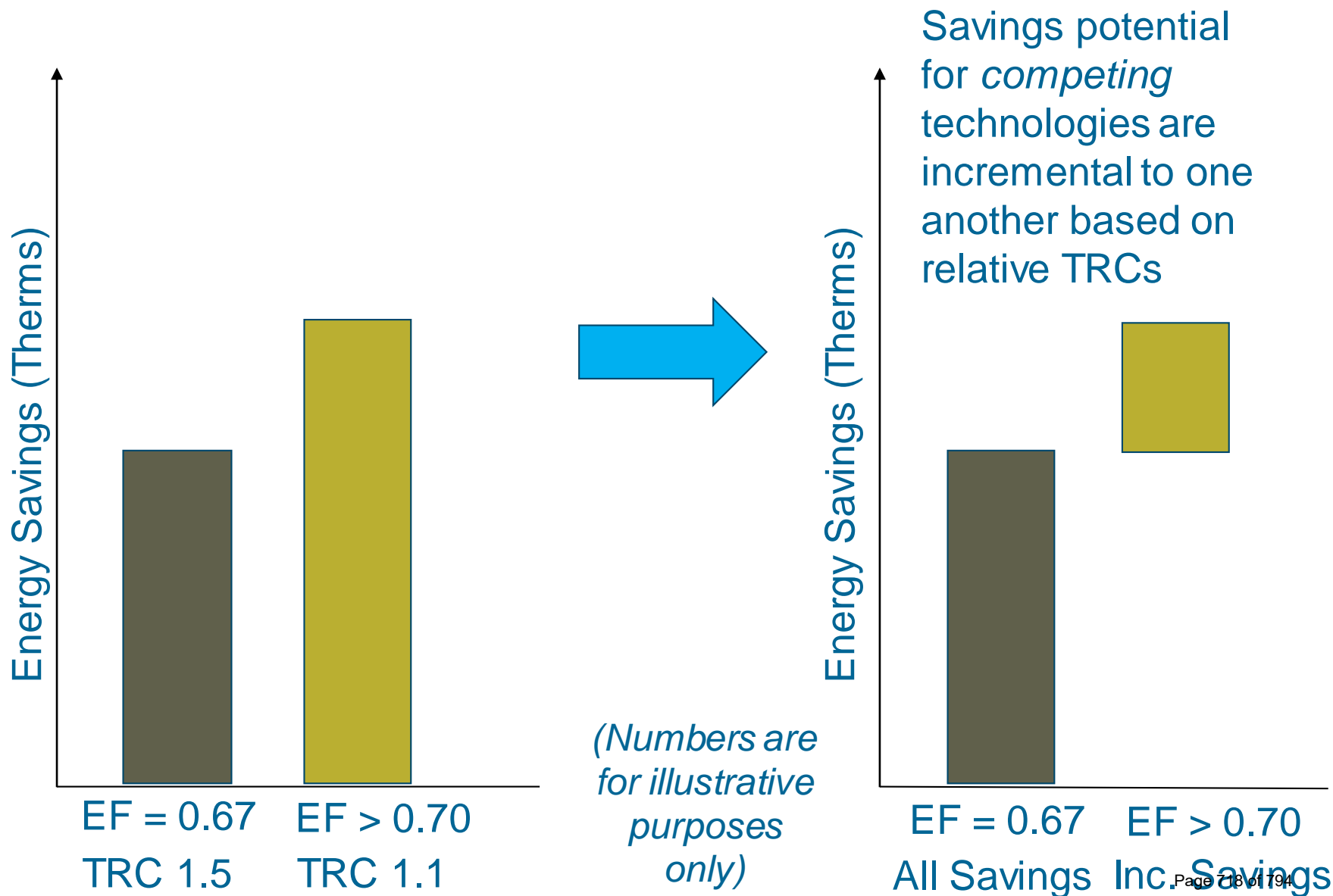



Cost-Effectiveness Screen

- Energy Trust utilizes the Total Resource Cost (TRC) test to screen measures for cost effectiveness

$$\text{TRC} = \frac{\text{Measure Benefits}}{\text{Total Measure Cost}}$$

- If TRC is > 1.0 , it is cost-effective
- Measure Benefits:
 - Avoided Costs (provided by Avista)
 - Annual measure savings x NPV avoided costs per therm
 - Quantifiable Non-Energy Benefits
 - Water savings, etc.

Total Measure Cost:

- The total cost of the EE measure (full cost if retrofit, incremental over baseline if replacement)

Cost-Effectiveness Override

Energy Trust applied this to measures found to be NOT Cost-Effective in the model but are offered through Energy Trust programs.

Reasons:

1. Blended avoided costs may produce different results than utility specific avoided costs
2. Measures offered under an OPUC exception per UM 551 criteria.

The following measures had the CE override applied (all under OPUC exception):

- Com Clothes Washers
- Res Insulation (ceiling, floor, wall)
- Res Clothes Dryers
- Res New Homes Packages

Emerging Technologies

Residential	Commercial	Industrial
<ul style="list-style-type: none"> • Path 5 Emerging Super Efficient Whole Home • Window Replacement (U<.20), Gas SF • Absorption Gas Heat Pump Water Heaters • Advanced Insulation 	<ul style="list-style-type: none"> • DOAS/HRV - GAS Space Heat • Gas-fired HP HW • Gas-fired HP, Heating • Advanced Windows 	<ul style="list-style-type: none"> • Gas-fired HP Water Heater • Wall Insulation- VIP, R0-R35

- Model includes savings potential from emerging technologies
- Factors in changing performance, cost over time
- Use risk factors to hedge against uncertainty

Risk Factors for Emerging Technologies

Exh. SJK-5

Risk Category	10%	30%	50%	70%	90%
Market Risk (25% weighting)	Requires new/changed business model Start-up, or small manufacturer Significant changes to infrastructure Requires training of contractors. Consumer acceptance barriers exist.		Training for contractors available. Multiple products in the market.	Trained contractors Established business models Already in U.S. Market Manufacturer committed to commercialization	
Technical Risk (25% weighting)	Prototype in first field tests. A single or unknown approach	Low volume manufacturer. Limited experience	New product with broad commercial appeal	Proven technology in different application or different region	Proven technology in target application. Multiple potentially viable approaches.
Data Source Risk (50% weighting)	Based only on manufacturer claims	Manufacturer case studies	Engineering assessment or lab test	Third party case study (real world installation)	Evaluation results or multiple third party case studies

Results

Outputs of Potential Type

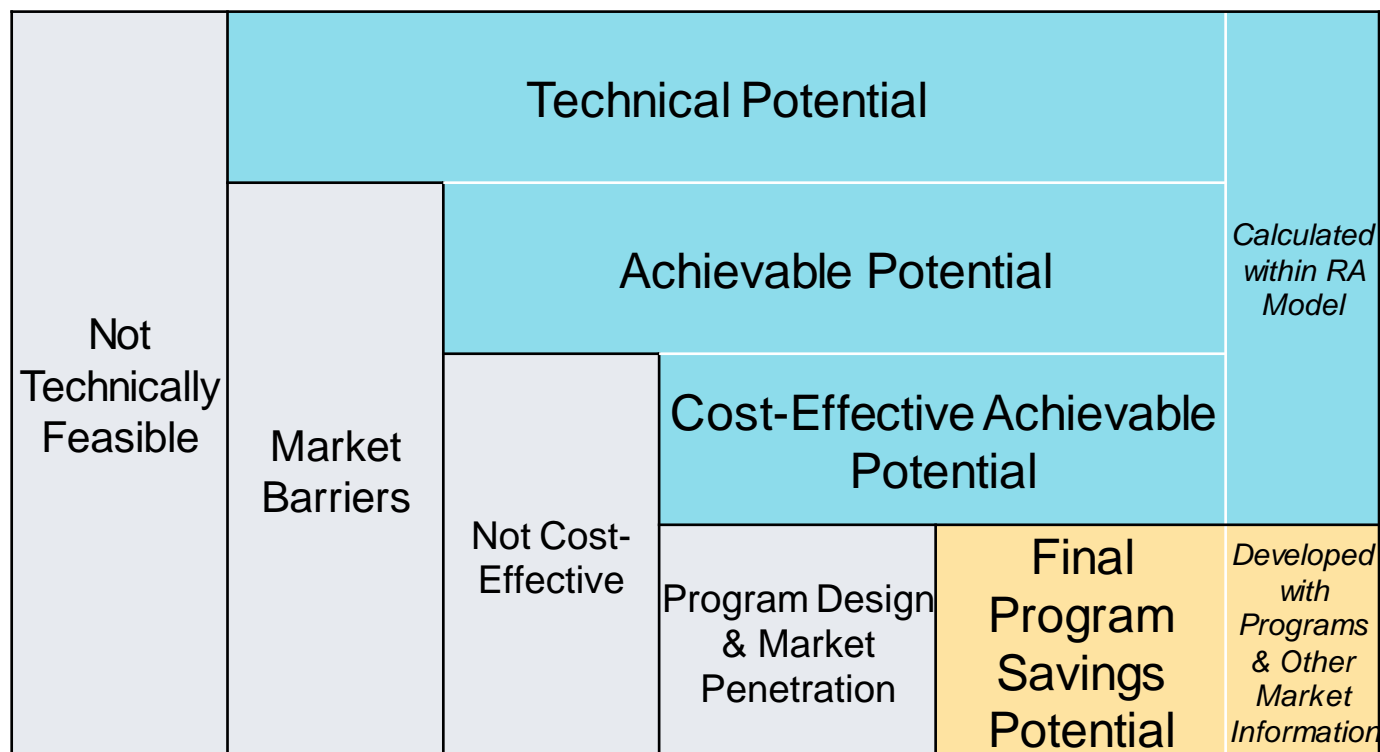

The RA Model estimates the in Technical, Achievable and Cost-Effective Achievable potential

Final Program Savings Potential is deployed exogenously of the model using the Cost-Effective Achievable potential from the RA model in combination with program expertise on what can be achieved

Overall Cumulative Savings Results

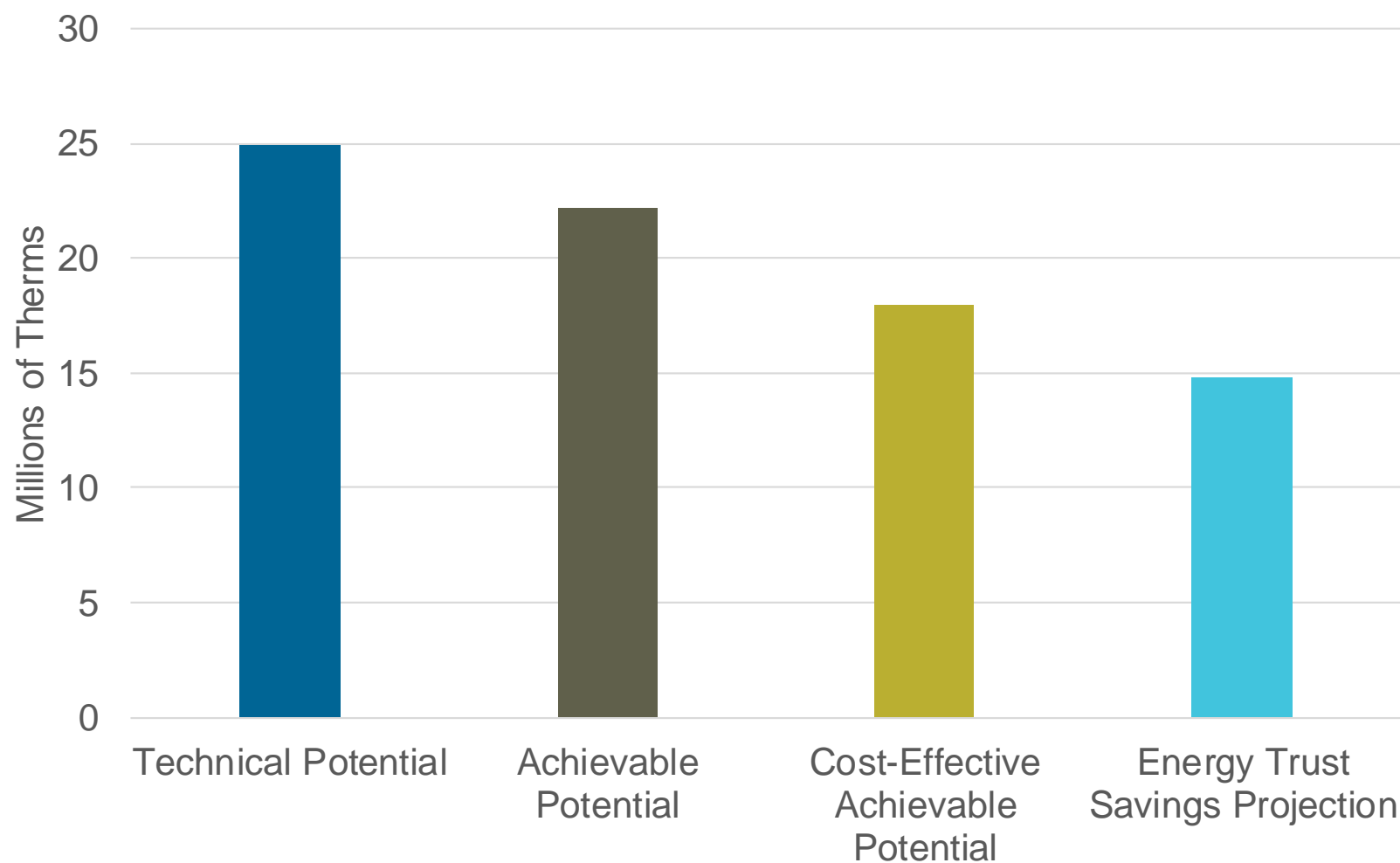

RA Model Results

Technical, Achievable, and Cost-Effective Achievable

Cumulative Potential by Type and Year

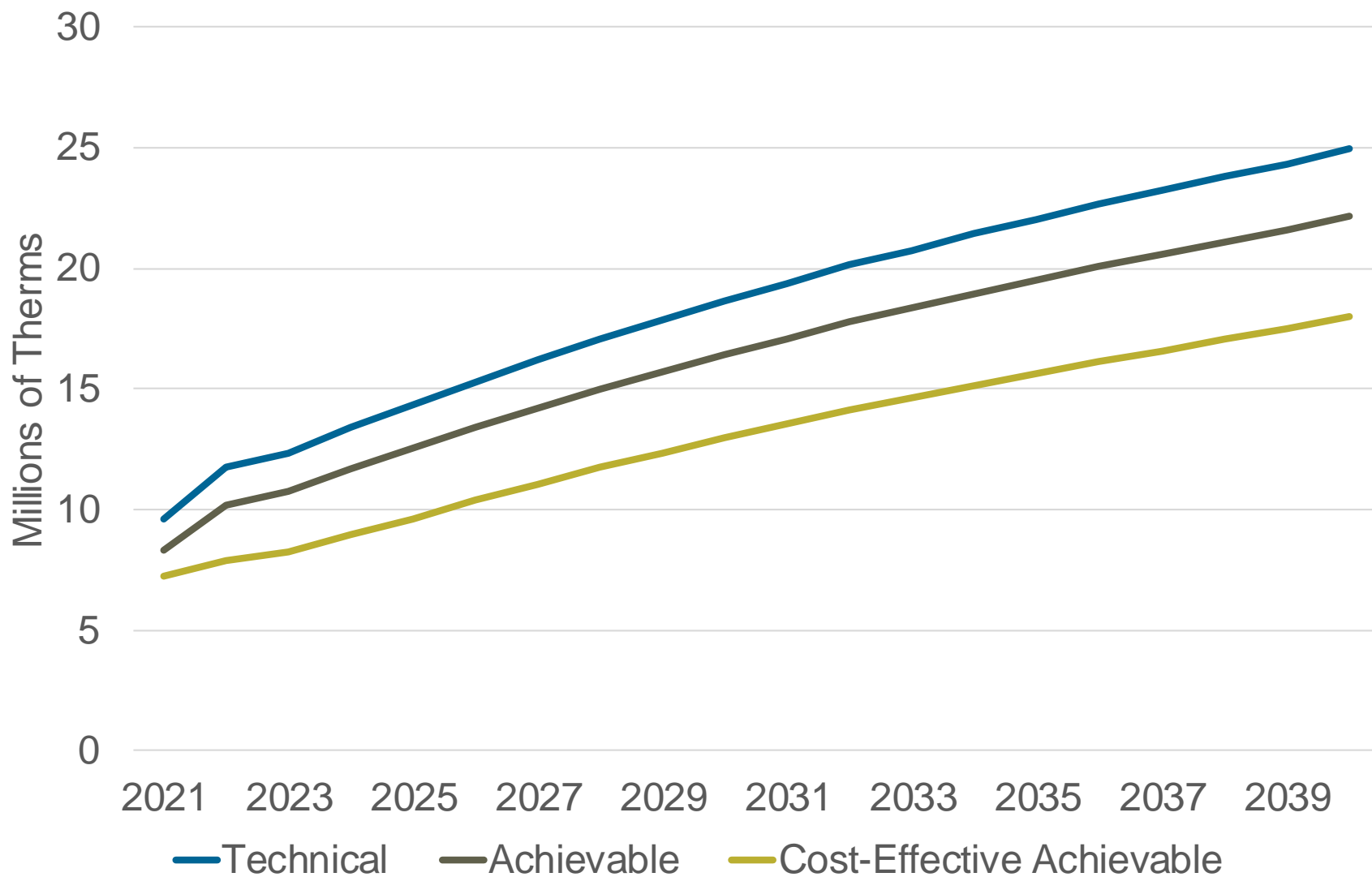

Contribution of Emerging Technology

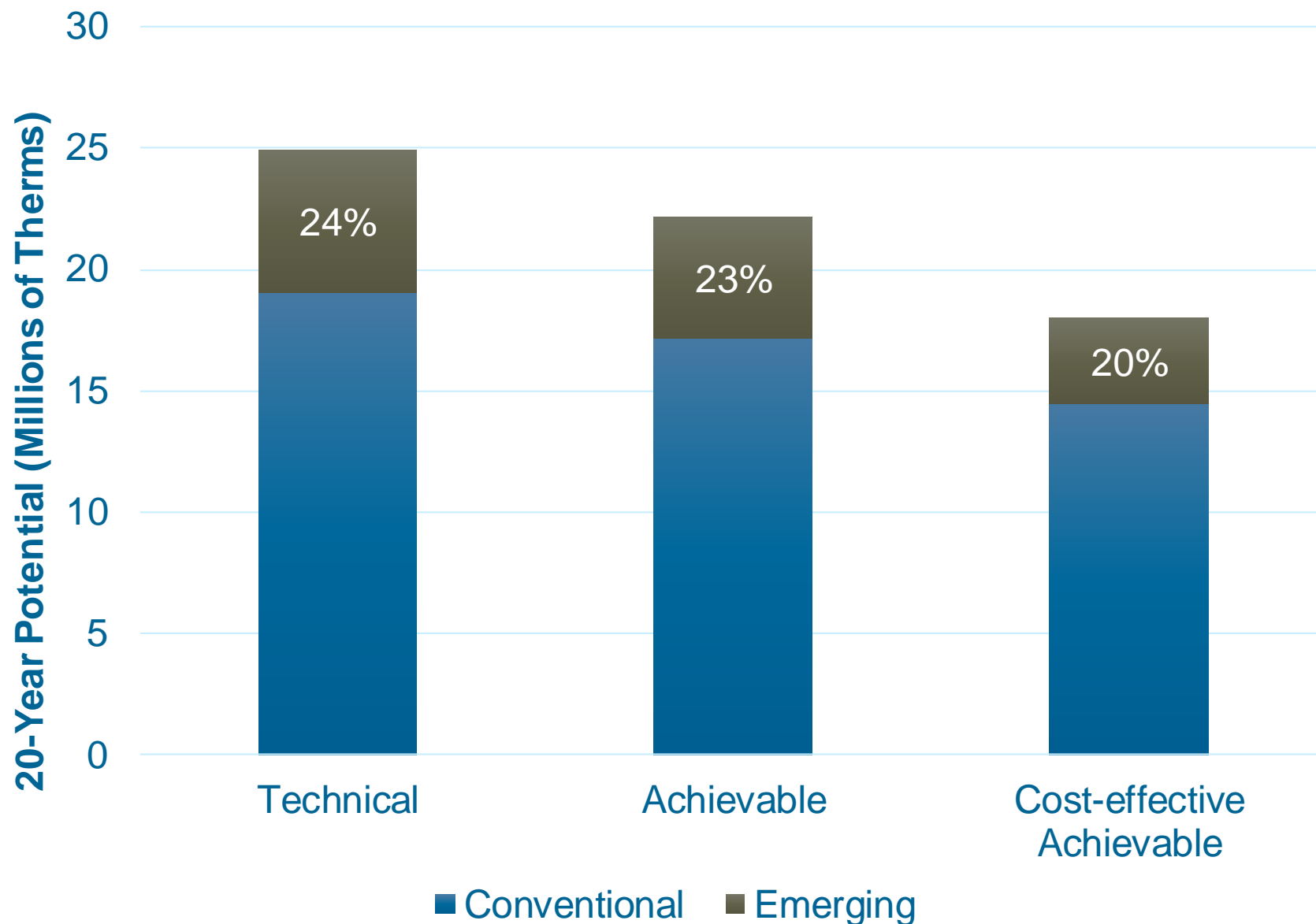

Cumulative Potential by Sector and Type

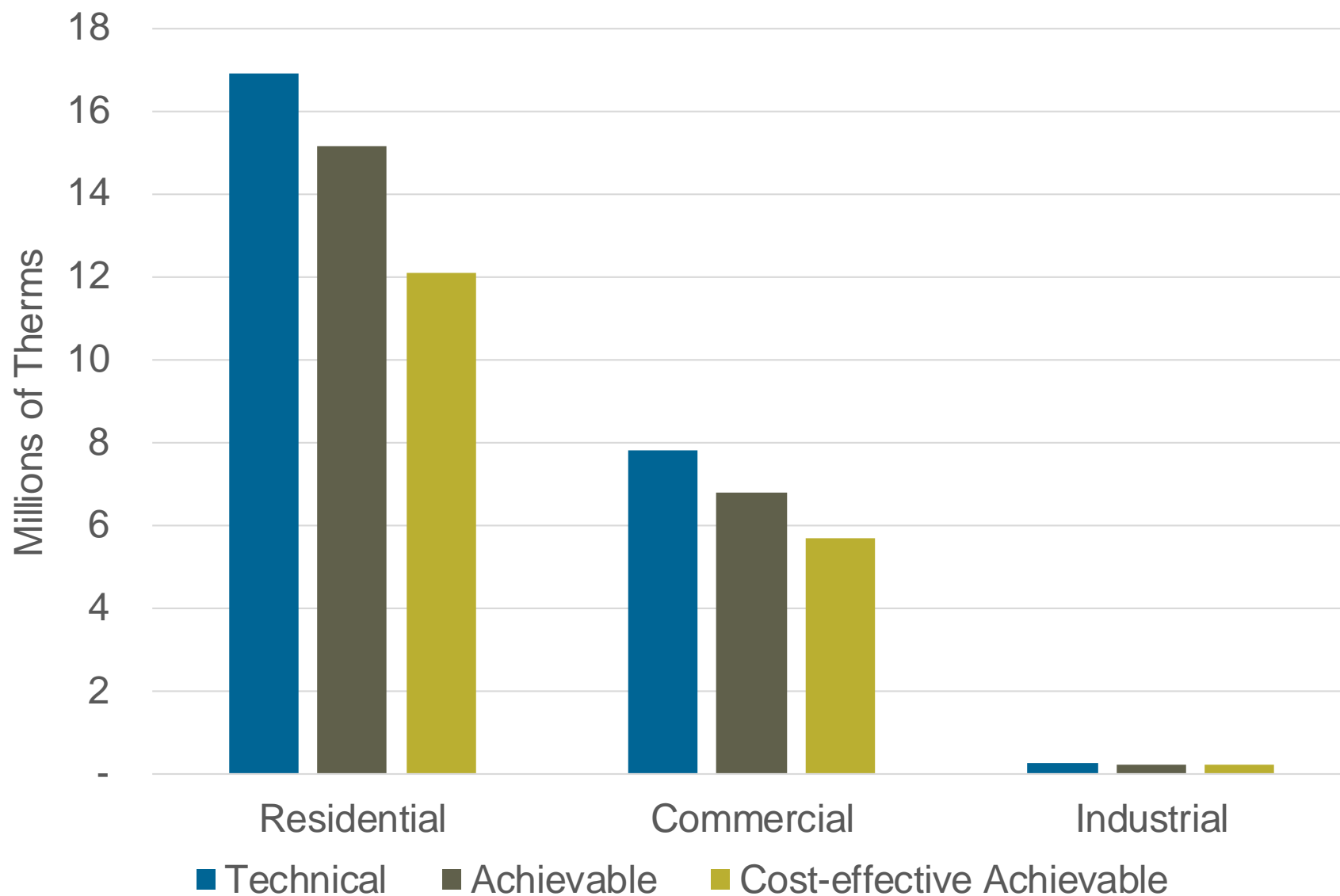

Cost-effective Achievable Potential by End Use

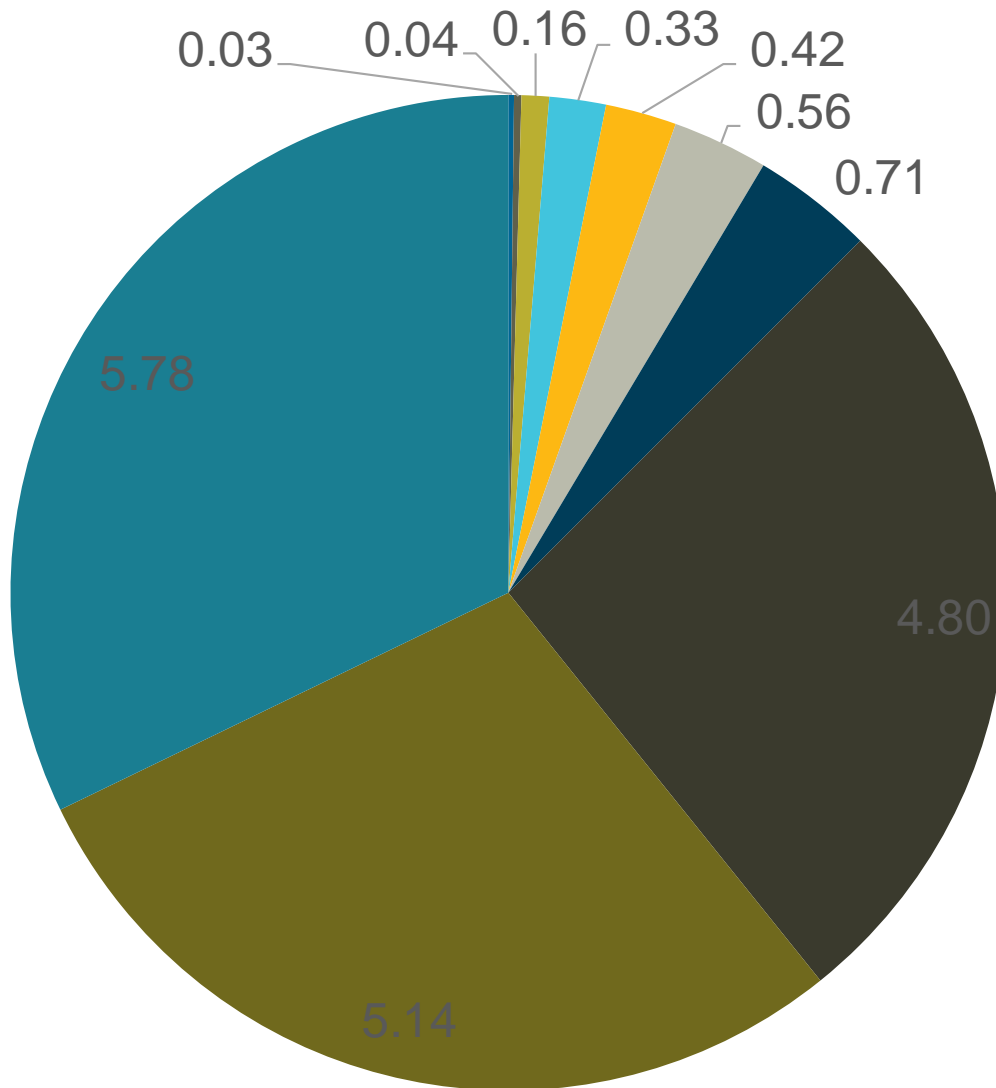

Cost-Effective Override Effect – (Millions of Therms)

Sector	Potential with Override	Potential without Override	Difference
Residential	12.1	10.9	1.2
Commercial	5.7	5.7	0.0
Industrial	0.2	0.2	0.0
Total	18.0	16.8	1.2

Measures with CE Override in Model:

- Res Insulation (ceiling, floor, wall)
- Res Clothes Dryers
- Res New Homes Packages
- Com Clothes Washers

Top-20 Measures

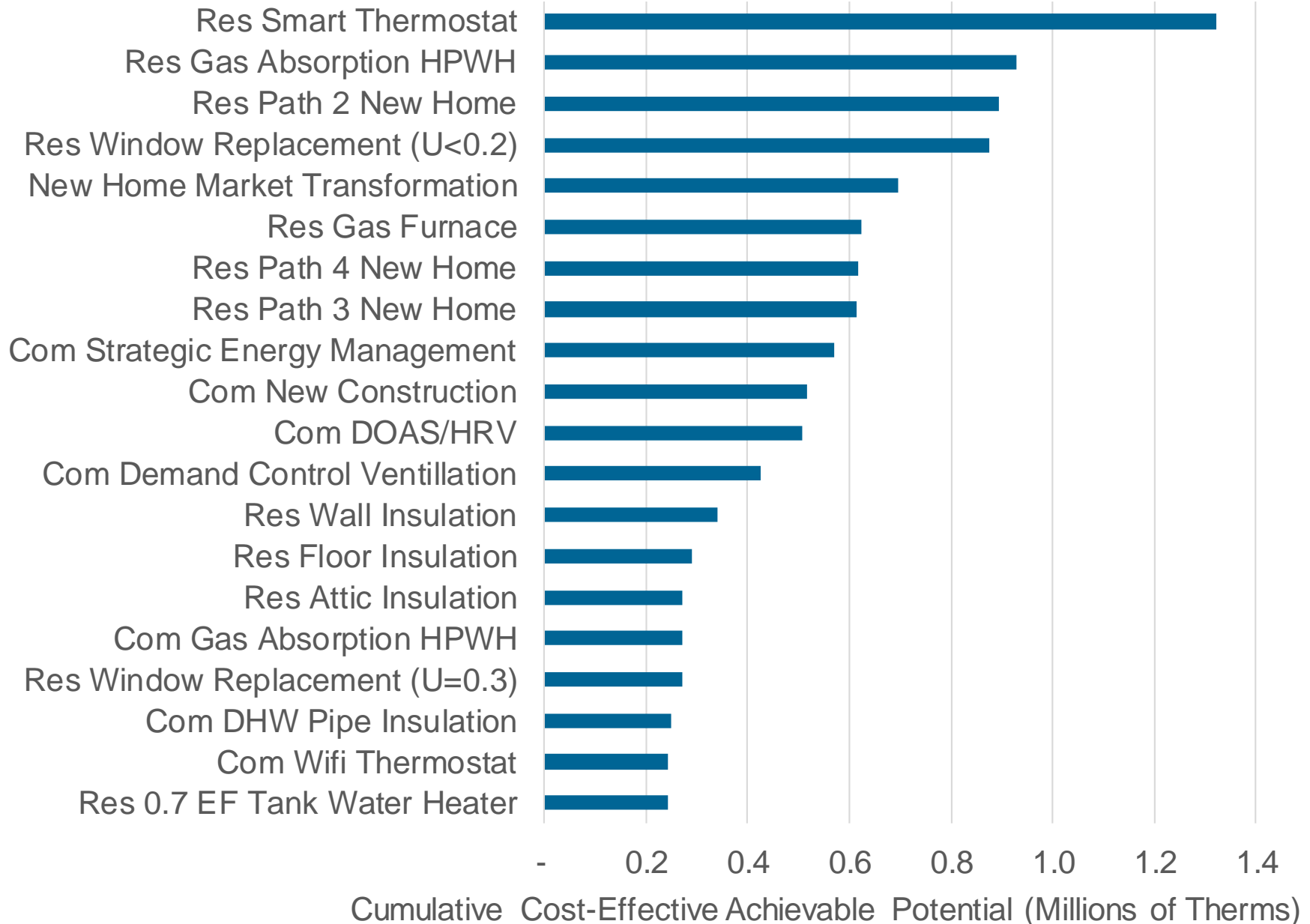

Final Savings Projections - Deployed Results

Final Savings Projection Methodology

Energy Trust sets the first five years of energy efficiency acquisition to program performance and budget goals.

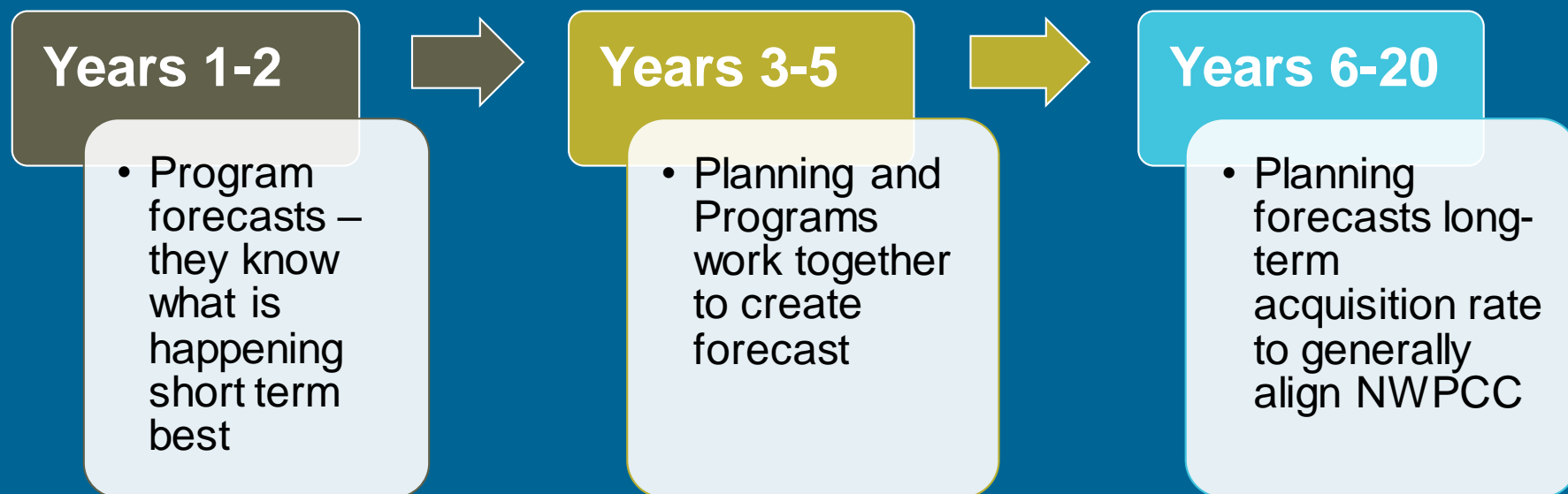

Cumulative Potential by Type – Millions of Therms

	Technical Potential	Achievable Potential	Cost-Effective Achievable Potential	Energy Trust Savings Projection
Residential	16.9	15.2	12.1	8.2
Commercial	7.8	6.8	5.7	6.1
Industrial	0.3	0.2	0.2	0.5
All Sectors	24.9	22.2	18.0	14.8

Not all Cost-Effective Potential is projected to be achieved because:

- Lost opportunity with 'Replacement' and 'New Constr.' measures
- Hard to reach measures (e.g. insulation)
- Other market barriers identified by programs & new service territory

Cost-Effective Savings

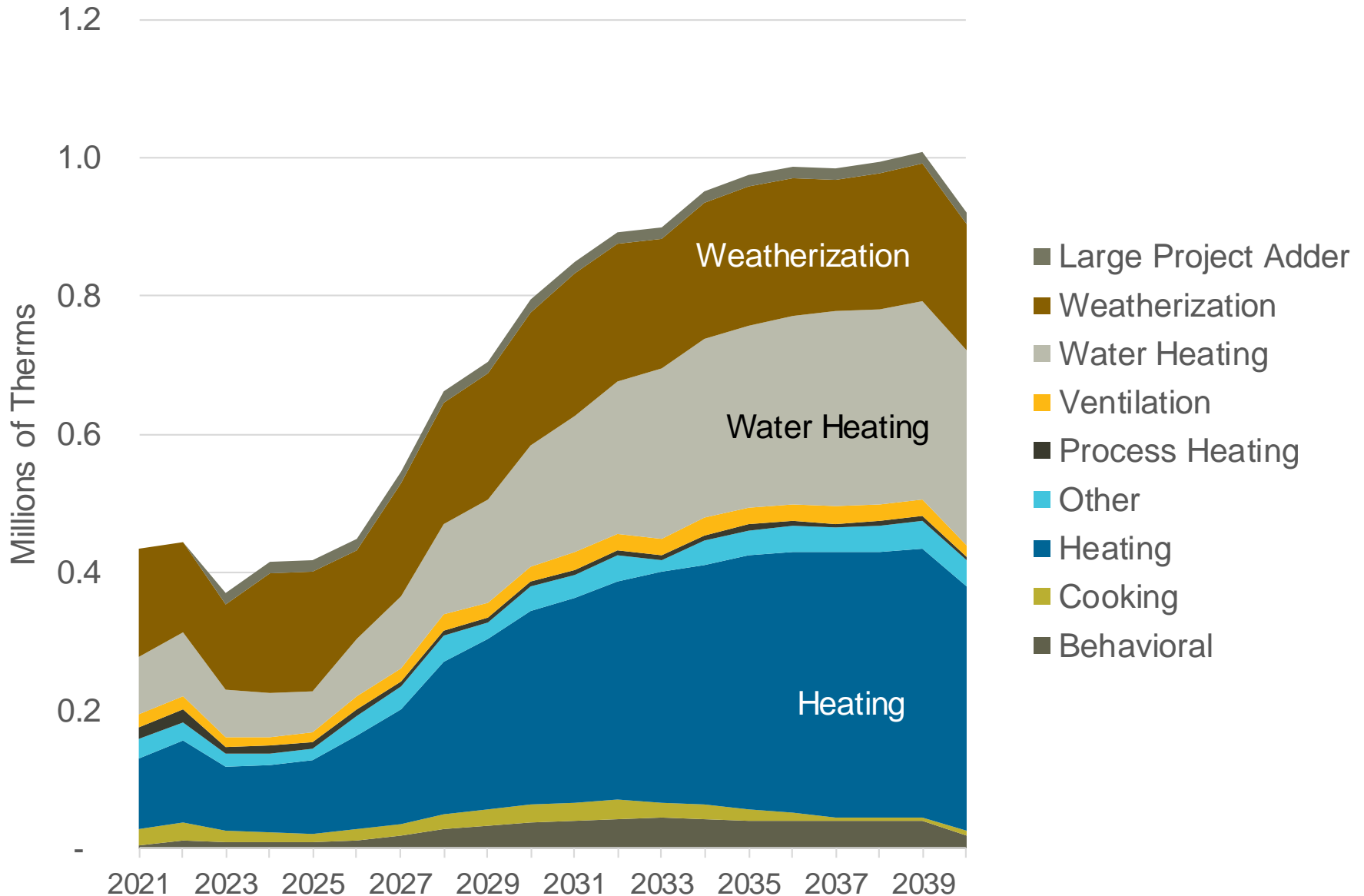

Projected Savings as Percent of Annual Load

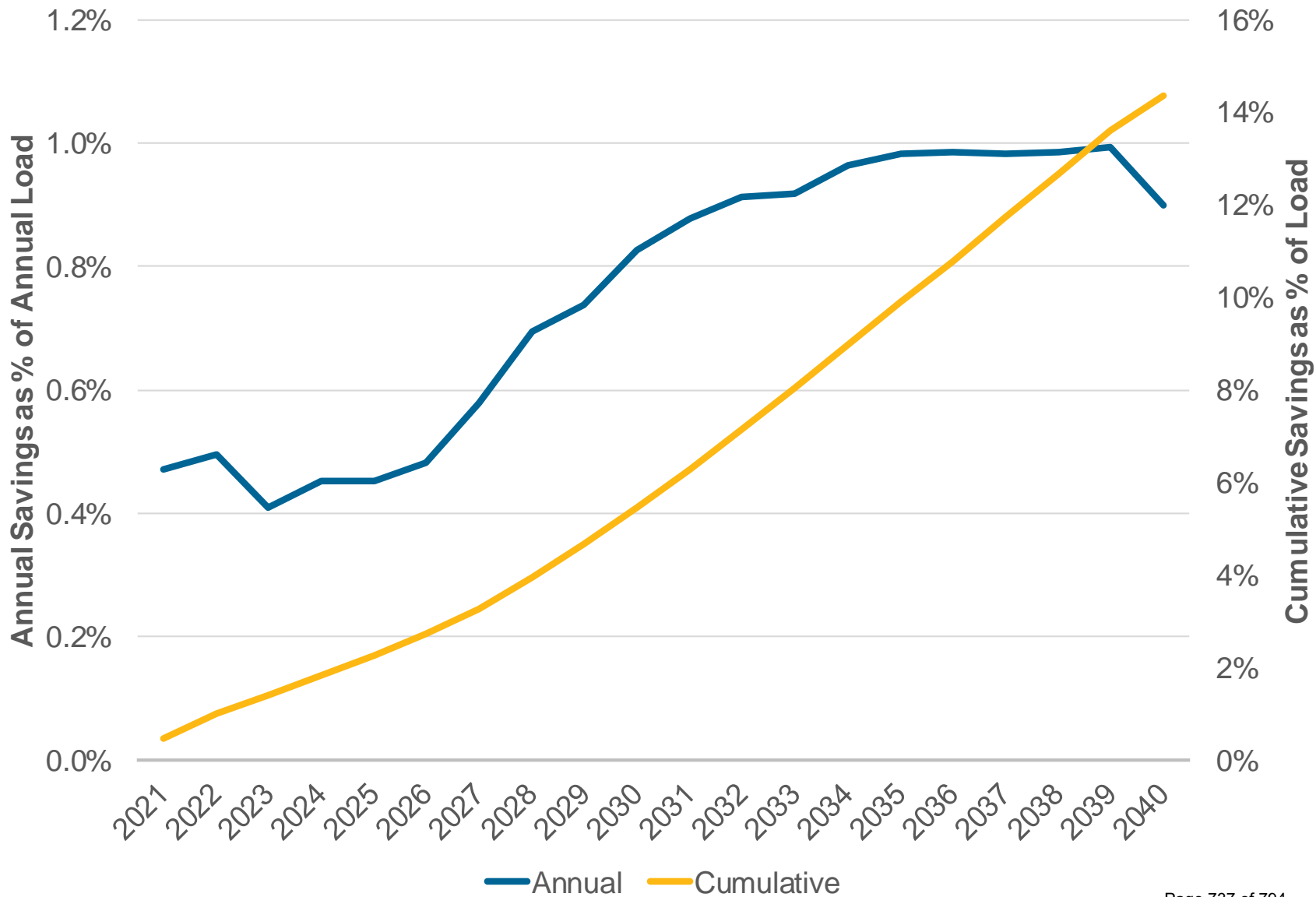

Levelized Cost Supply Curve

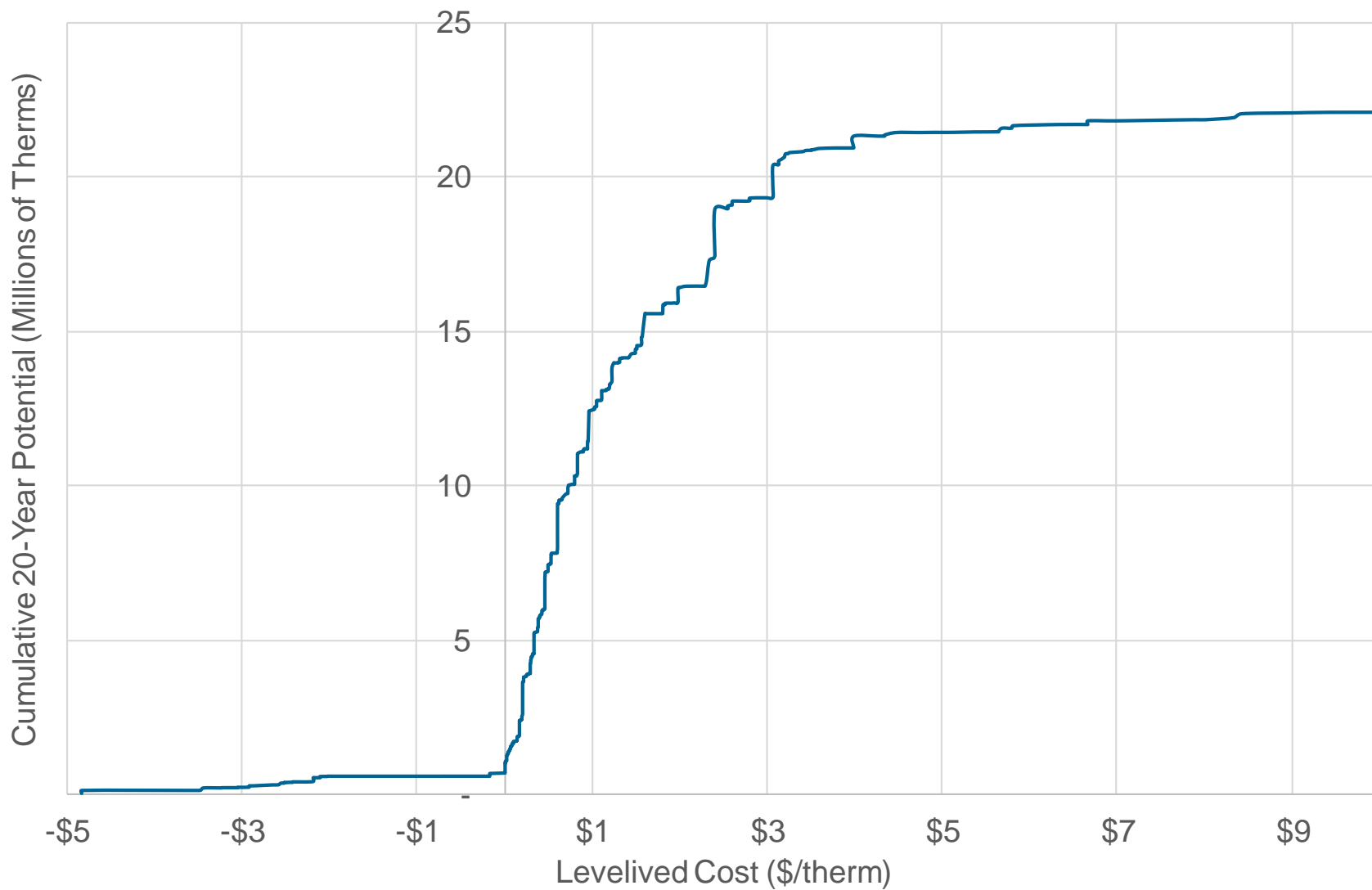

Benefit Cost Ratio Supply Curve

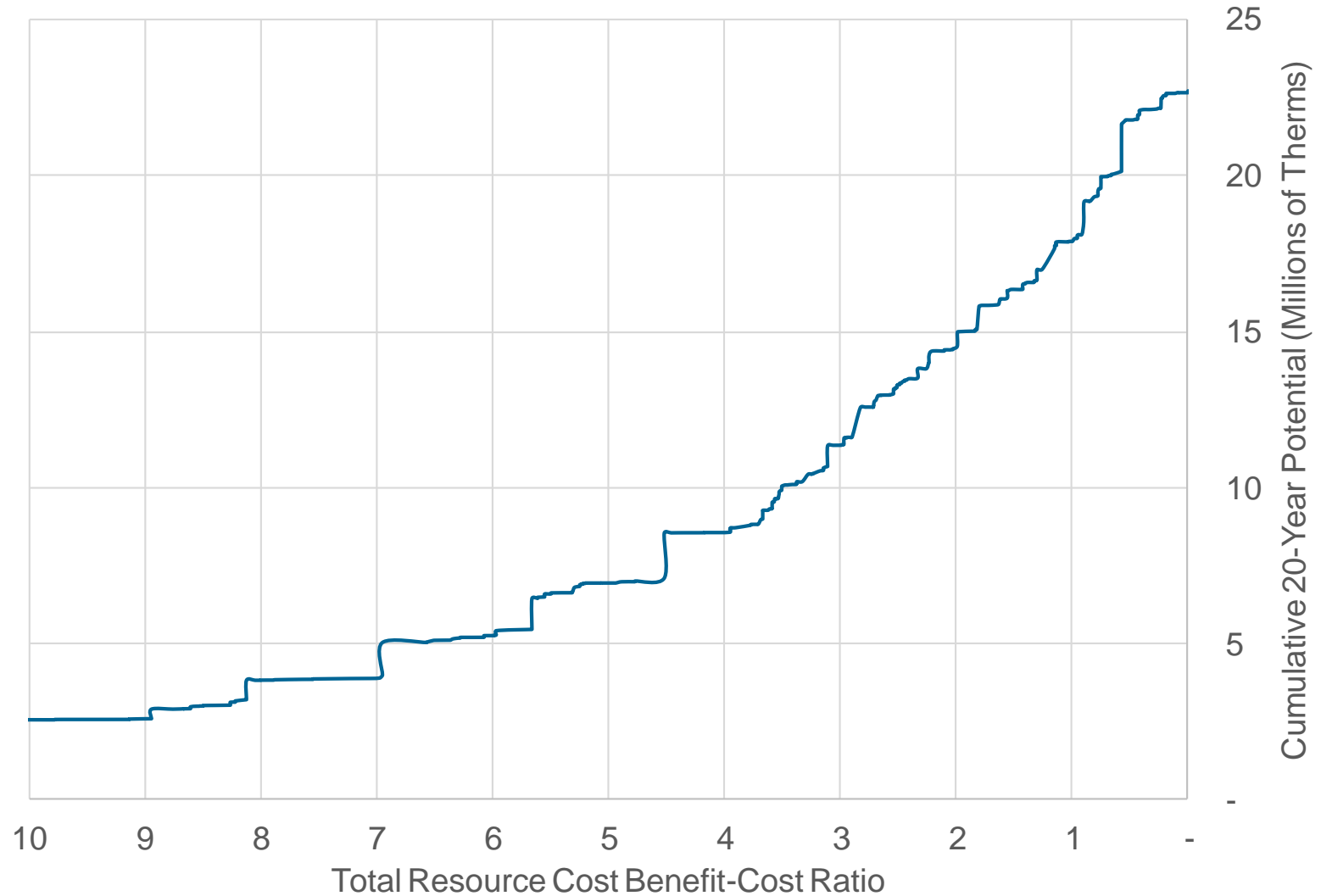



Thank you

Spencer Moersfelder,
Planning Manager

spencer.moersfelder@energytrust.org
503.548.1596

Ted Light,
Lighthouse Energy Consulting

ted@lighthouseenergynw.com
503.395.5310



Sendout Model

Modeling Transportation In SENDOUT®

- Start with a point-in-time look at each jurisdiction's resources
 - Contracts – Receipt and Delivery Points
 - Rates
- Contractual vs. Operational
 - Contractual can be overly restrictive
 - Operational can be overly flexible
- Incorporating operational realities into our modeling can defer the need to acquire new resources
- Gas Supply's job is to get gas from the supply basin to the pipeline citygate
- Gas Engineering/Distribution's job is to take gas from the pipeline citygate to our customers
- The **major** limiting factor is receipt quantity – how much can you bring into the system?

Modeling Challenges

- Supply needs to get gas to the gate
- Contracts were created years ago, based on demand projections at that point in time
- Stuff happens (i.e. growth differs from forecast)
- Sum of receipt quantity and aggregated delivery quantity don't identify resource deficiency for quite some time however.....
- The aggregated look can mask individual city gate issues, and the disaggregated look can create deficiencies where they don't exist
- In many cases, operational capacity is greater than contracted
- Transportation resources are interconnected (two pipes can serve one area)
- WARNING – we need to be mindful of the modeling limitations

What is in SENDOUT®?

Inside:

- Demand forecasts at an aggregated level
- Existing firm transportation resources and current rates
 - Receipt point to aggregated delivery points/“zone”
 - Jurisdictional considerations
 - Long term capacity releases
- Potential resources, both supply and demand side

What is outside SENDOUT®?

Outside:

- Gate station analysis
 - Forecasted demand behind the gate
 - Growth rates consistent with IRP assumptions
 - Actual hourly/daily city gate flow data
 - Gate station MDDO's
 - Gate station operational capacities

Supply

Interconnect

Demand

Transport

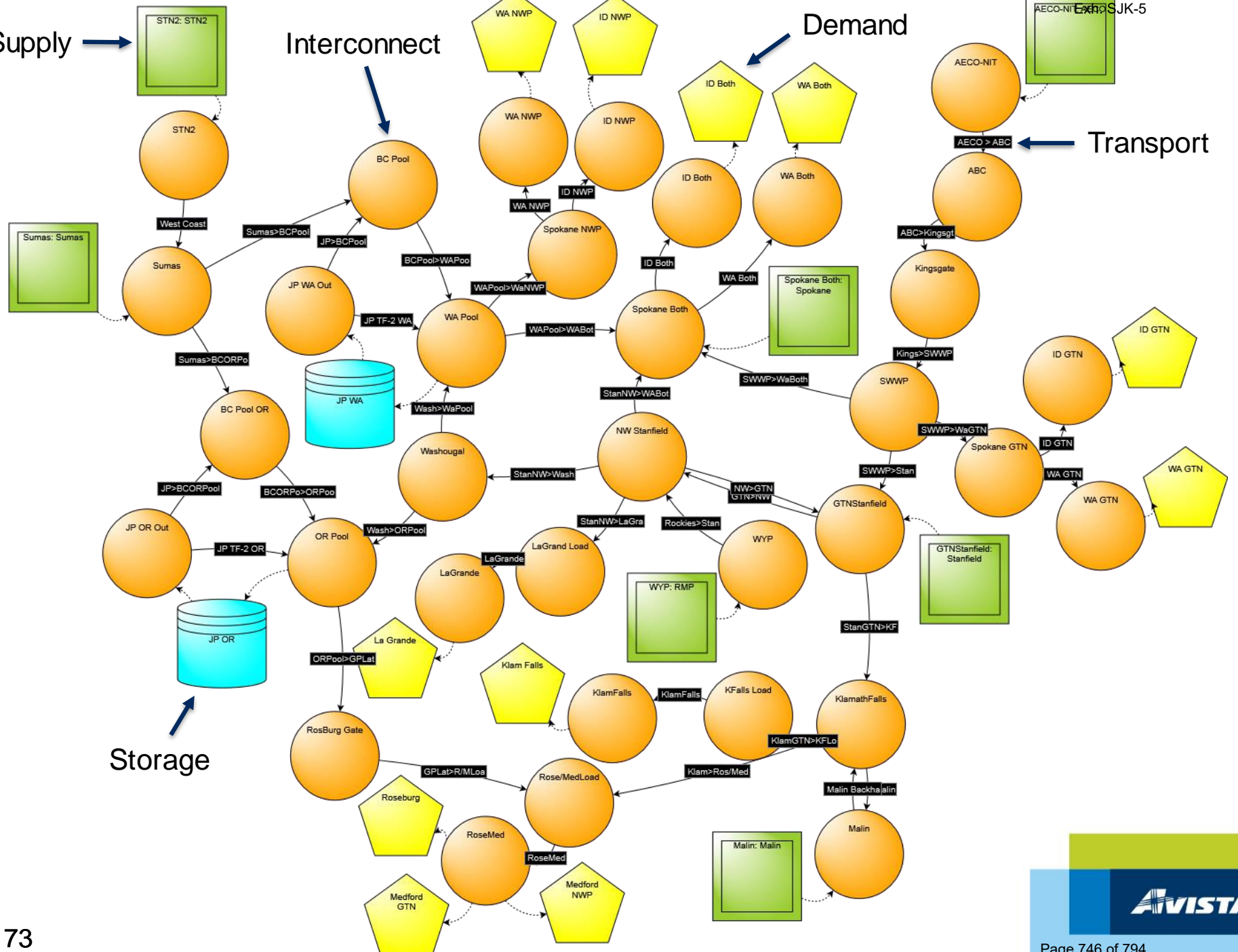

Storage

New Planning Software

- Avista is looking for a new software solution to model our natural gas system and the increasingly complex system with carbon reduction goals
- We hope to have this software available for the next round of Integrated Resource Planning (IRP) and to model it in parallel with Sendout



Assumptions Review

Firm Customers (Meters) by State and Class, 2019

Firm Customers by State

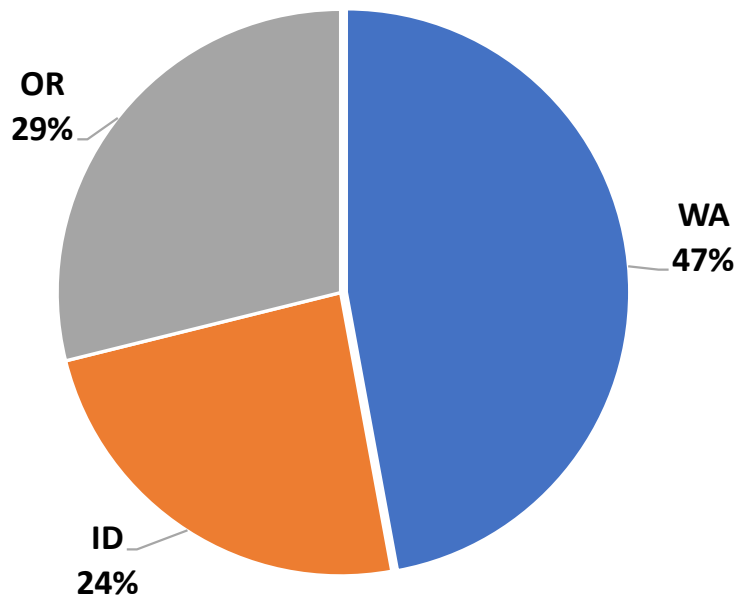

Firm Customers by Class

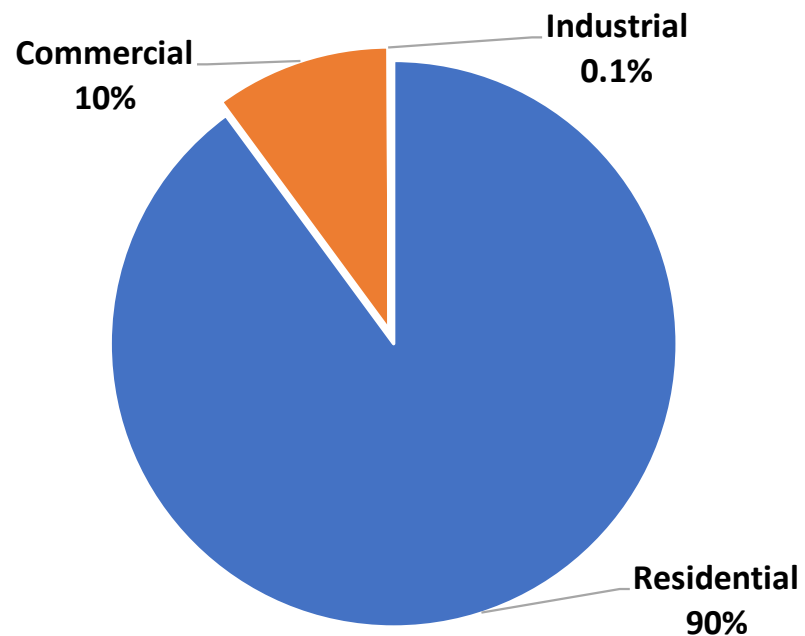

WA-ID Region Firm Customer Range, 2021-2045

Variable	Low Growth	Base Growth	High Growth
WA-ID Customers	0.7%	1.1%	1.5%
WA Population	0.4%	0.7%	1.0%
ID Population	0.8%	1.4%	2.0%
WA-ID Population	0.5%	0.8%	1.2%

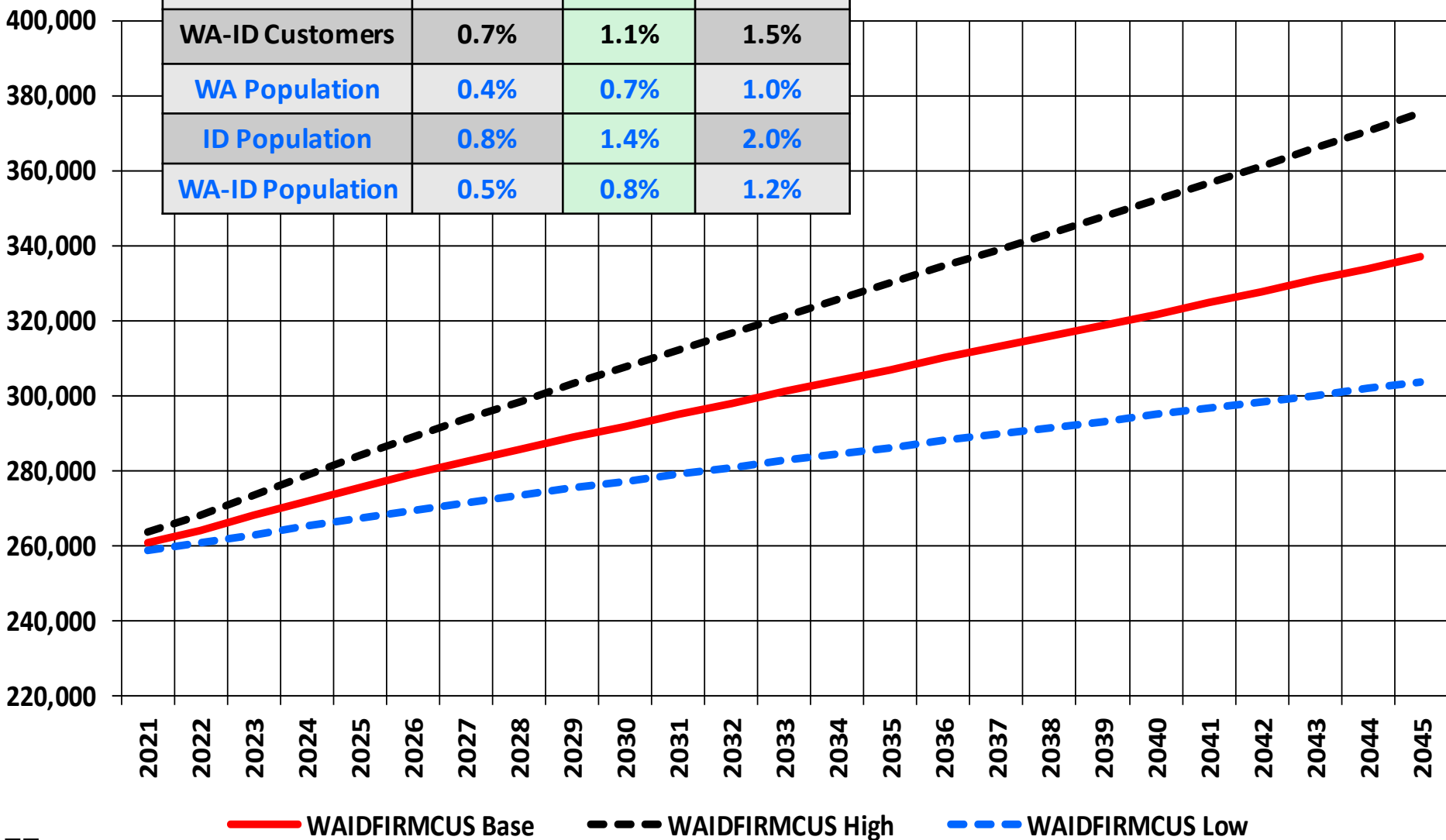

OR Region Firm Customer Range, 2021-2045

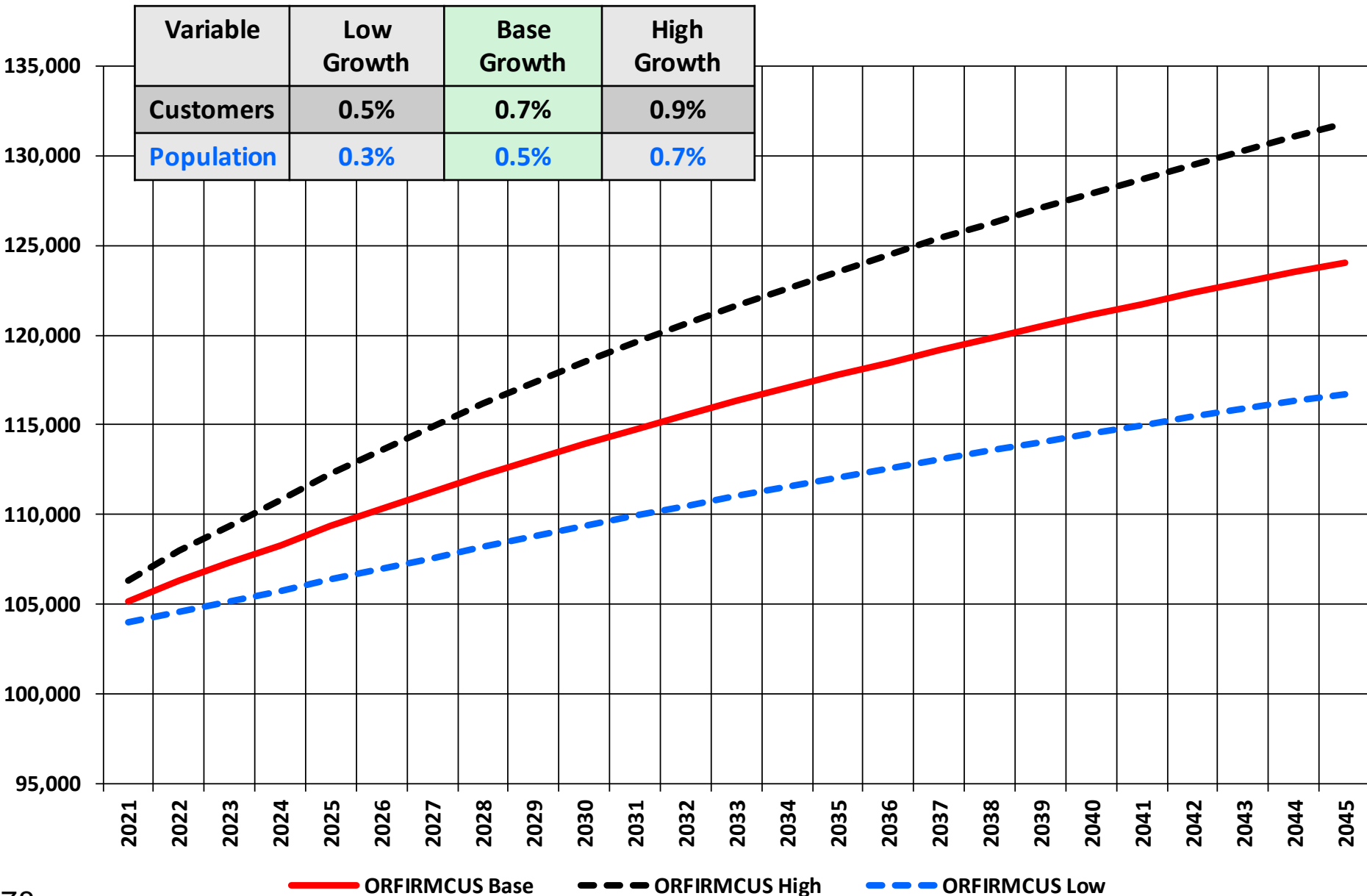

System Firm Customer Range, 2021-2045

Variable	Low Growth	Base Growth	High Growth
Customers	0.6%	1.0%	1.3%
Population	0.4%	0.8%	1.1%

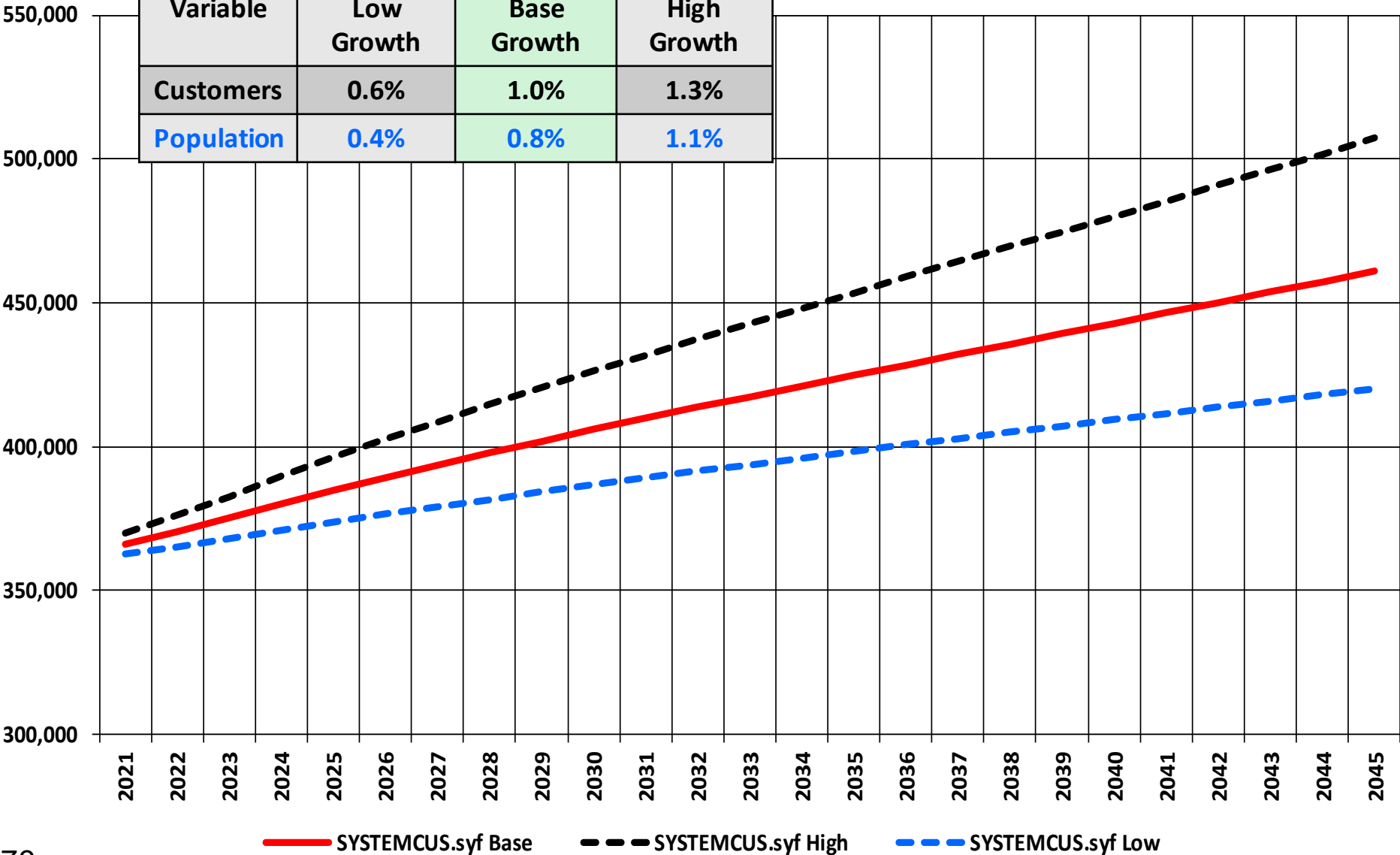

Summary of Growth Rates

System	Base-Case	High	Low
Residential	1.0%	1.4%	0.7%
Commercial	0.5%	0.8%	0.1%
Industrial	-0.8%	2.2%	-3.8%
Total	1.0%	1.3%	0.6%
WA			
System	Base-Case	High	Low
Residential	1.0%	1.3%	0.7%
Commercial	0.4%	0.7%	0.1%
Industrial	-0.8%	1.9%	-3.6%
Total	1.0%	1.3%	0.7%
ID			
System	Base-Case	High	Low
Residential	1.4%	2.0%	0.8%
Commercial	0.4%	1.0%	-0.2%
Industrial	-1.0%	1.8%	-3.4%
Total	1.3%	1.9%	0.7%
OR			
System	Base-Case	High	Low
Residential	0.7%	0.9%	0.5%
Commercial	0.6%	0.8%	0.4%
Industrial	0.0%	4.5%	-10.6%
Total	0.7%	0.9%	0.5%

Base Coefficients (July and August Averaged)



- ID Res
- WA Res



- Klamath Falls Res
- LaGrande Res
- Medford Res
- Roseburg Res



Heat Coefficients

Planning Area - Residential Class	2 Year	3 Year	5 Year
Roseburg (Oregon)	0.008829	0.008046	0.00699
Medford (Oregon)	0.00639	0.0065	0.006068
La Grande (Oregon)	0.006223	0.007297	0.00665
Klamath Falls (Oregon)	0.005284	0.005268	0.004902
Idaho	0.006445	0.006344	0.005896
Washington	0.006307	0.006313	0.005957

*Avg. of monthly heat coefficient



*Historic Data – adjusted by price elasticity and DSM

Price Elasticity

- The elasticity as measured in the Medford and Roseburg areas will be used for the entire system as estimated elasticity.
- 0.81% decrease only for each price rise of 10%
- This elasticity is measured through heat coefficients and annual price changes

Avista Weather Planning Standard

- Utilize coldest day for each of the past 30 years with a 99% probability supply can be fulfilled

Area	99% Probability Avg. Temp
La Grande	-11
Klamath Falls	-9
Medford	11
Roseburg	14
Spokane	-12

Henry Hub Expected Price and Average Annual Price Forecasts

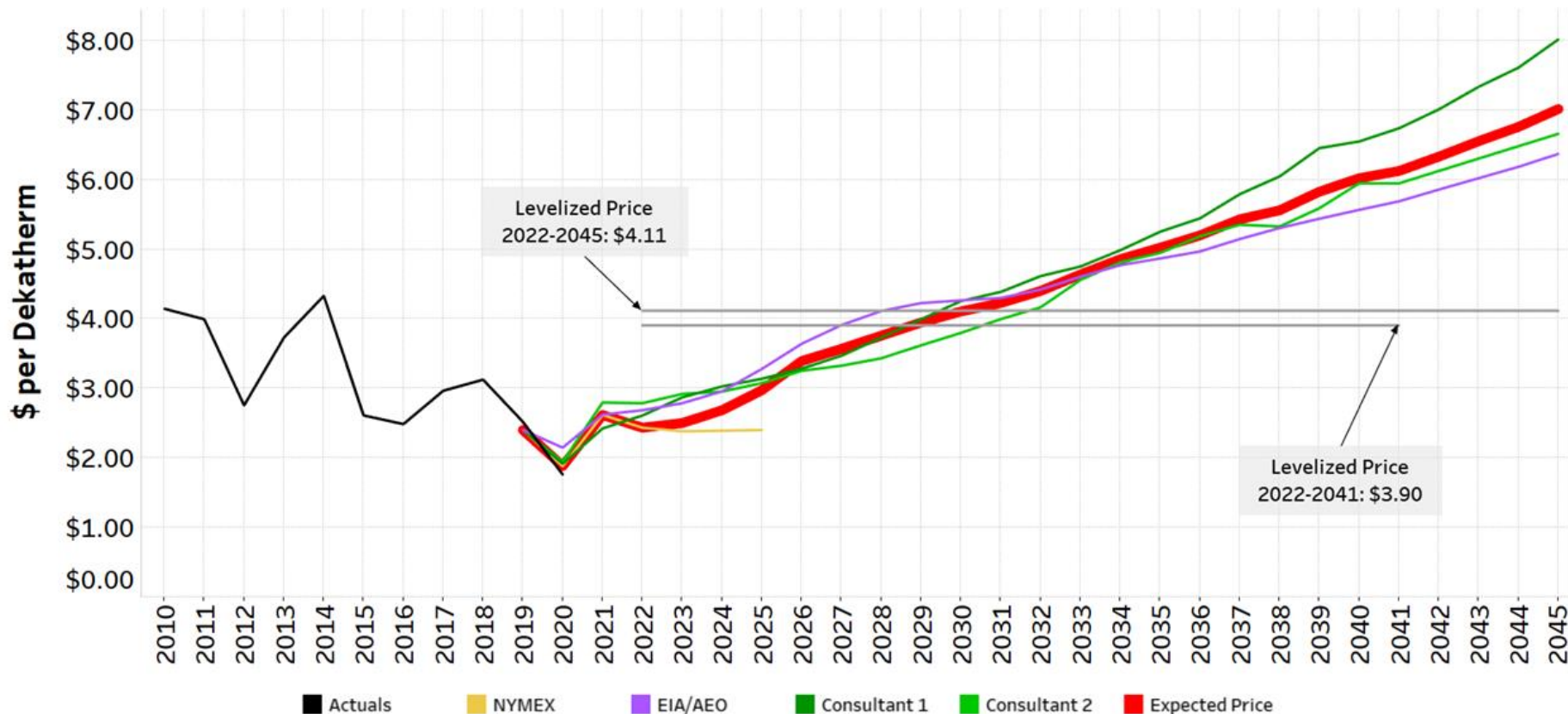

Stochastic Prices (Results from 1000 Draws)

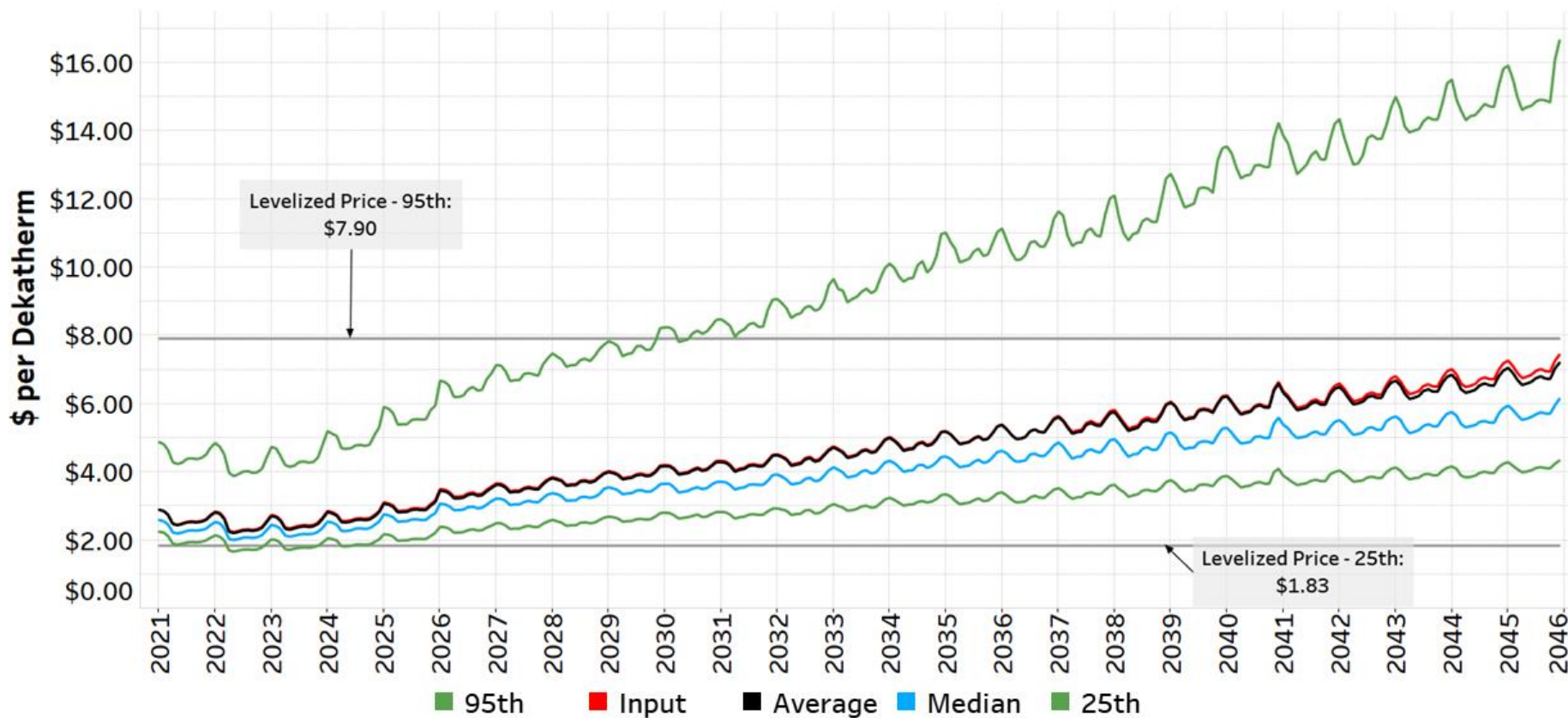

2020 Henry Hub Prices - Nominal

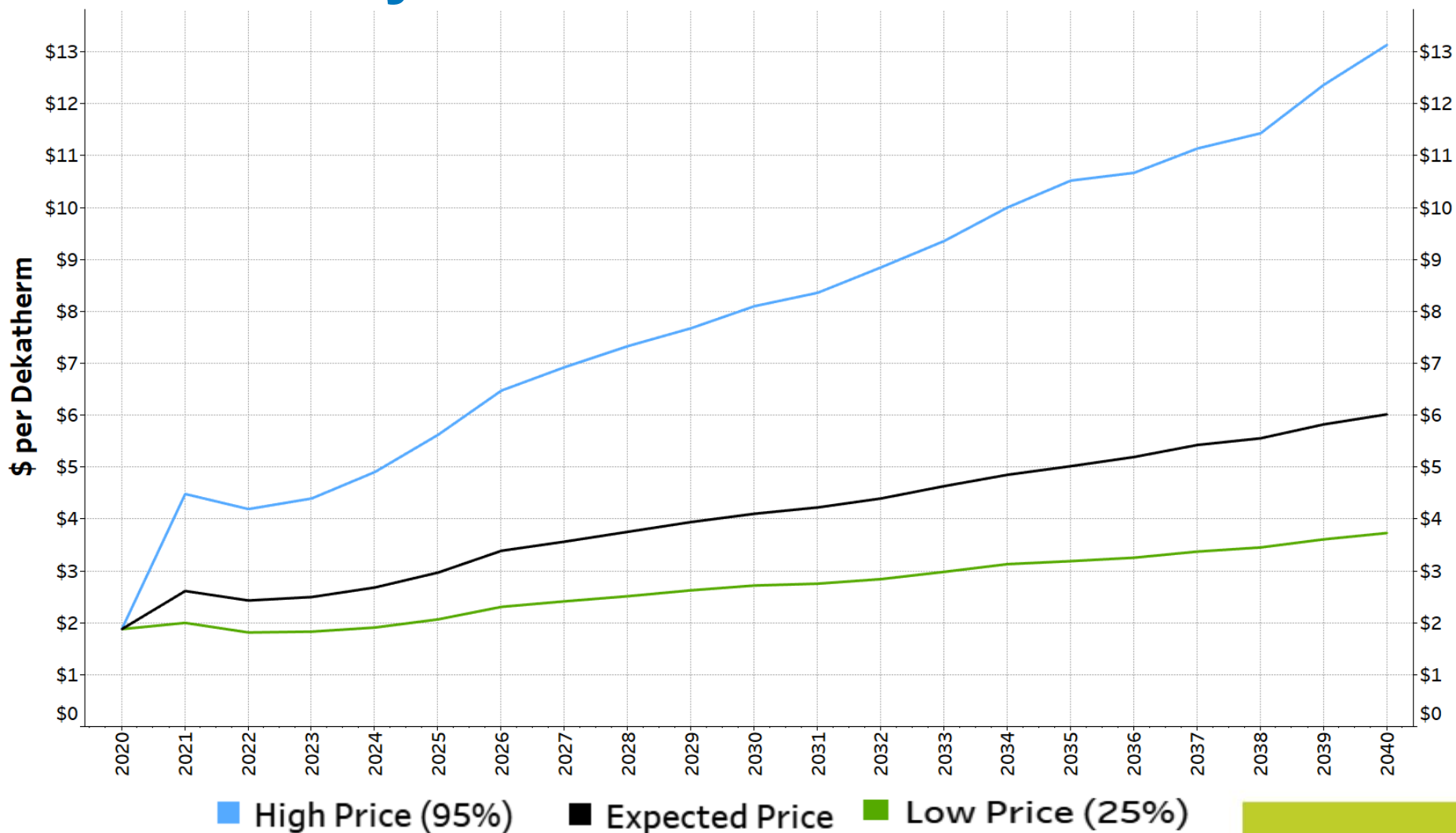

Prices by Gas Hub (Henry Hub Expected Price + Basis)

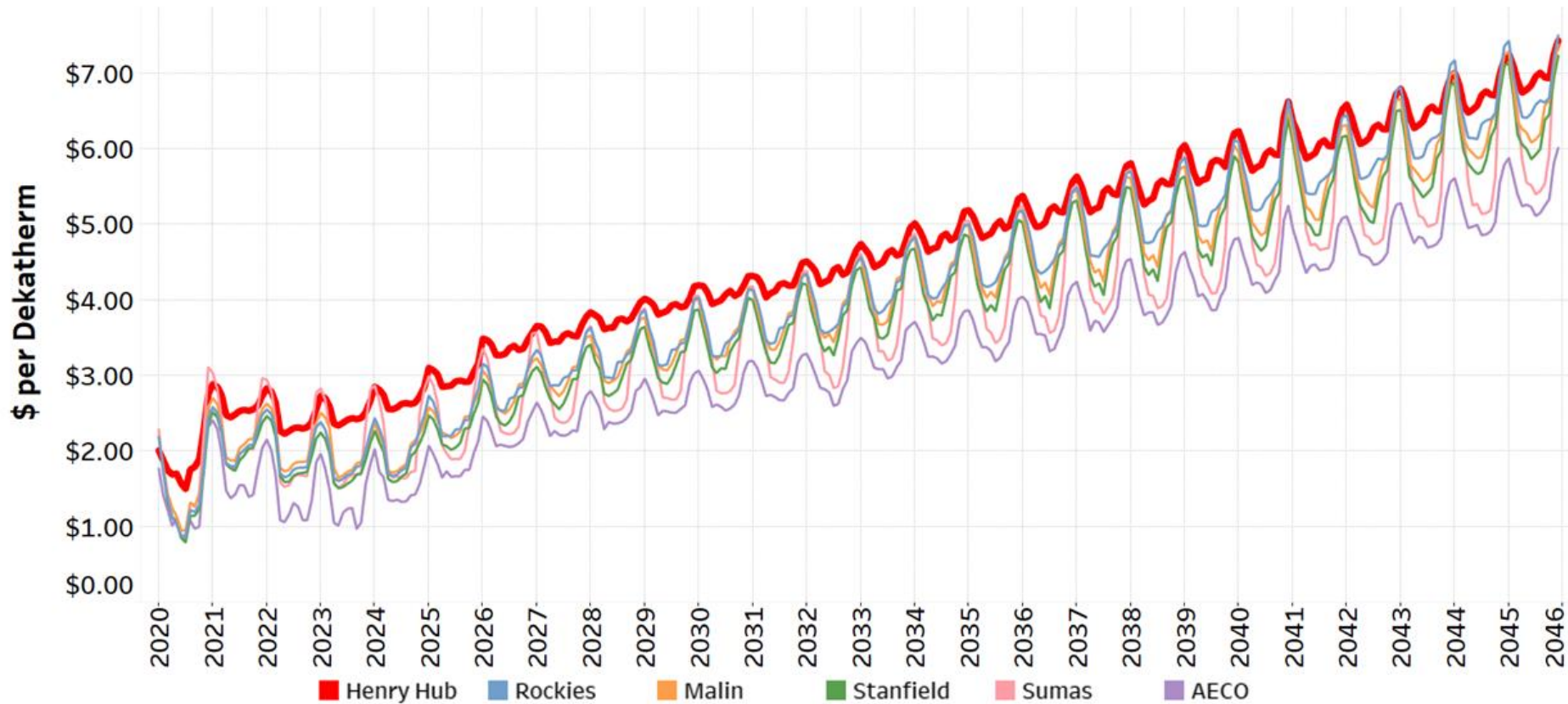

Expected Case

Cost of Carbon by State - Summary

- Washington - Social cost of carbon @ 2.5% discount rate;
 - upstream emissions associated with natural gas drilling and transportation of natural gas to its end use.
- Oregon is based off a Wood Mackenzie estimate for Cap and Trade
- Idaho - carbon prices will not be included

Carbon Costs

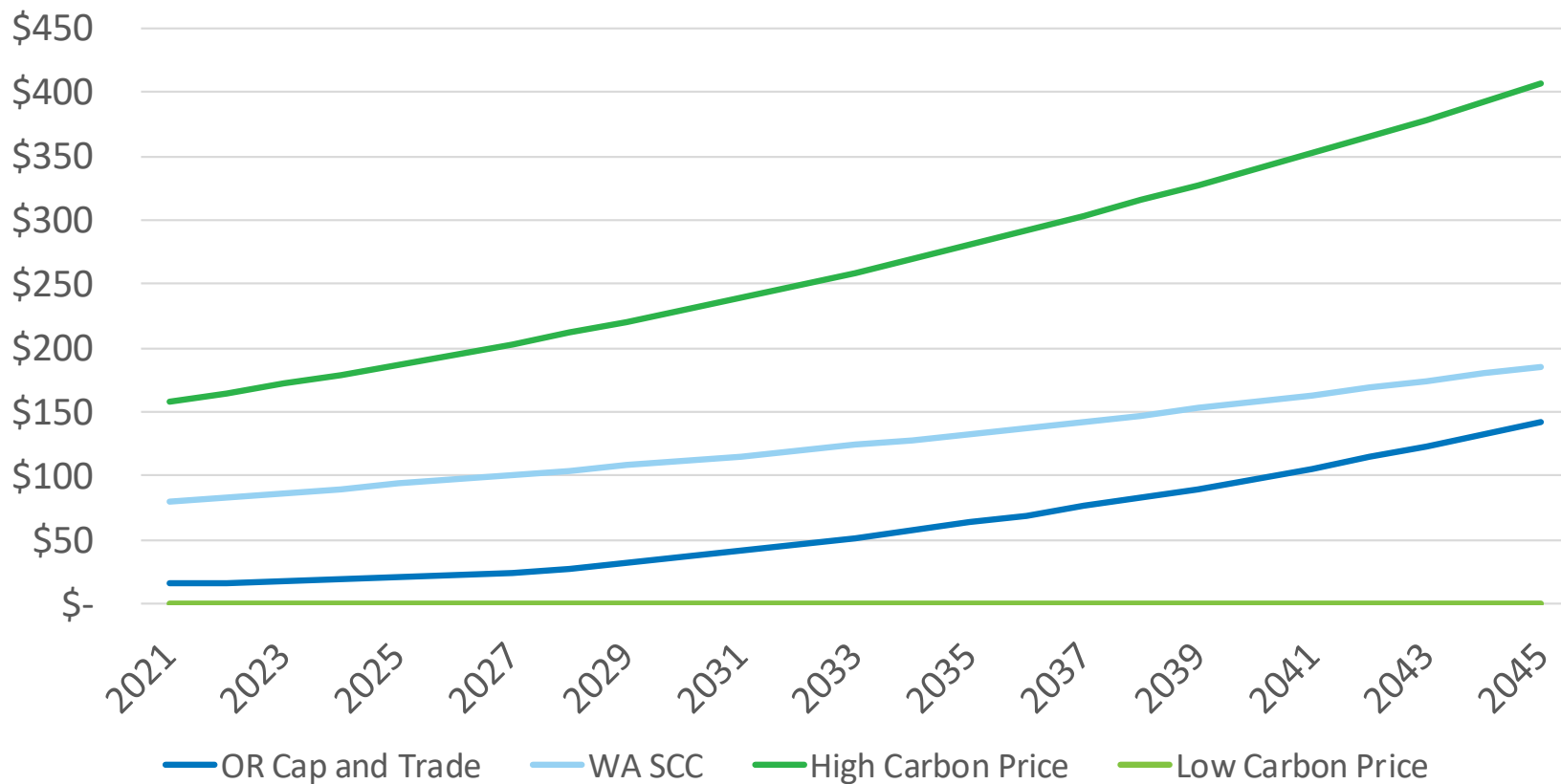

Levelized
Cost per
MTCO₂e

\$44.92

\$113.75

\$234.45

\$0

Carbon Costs

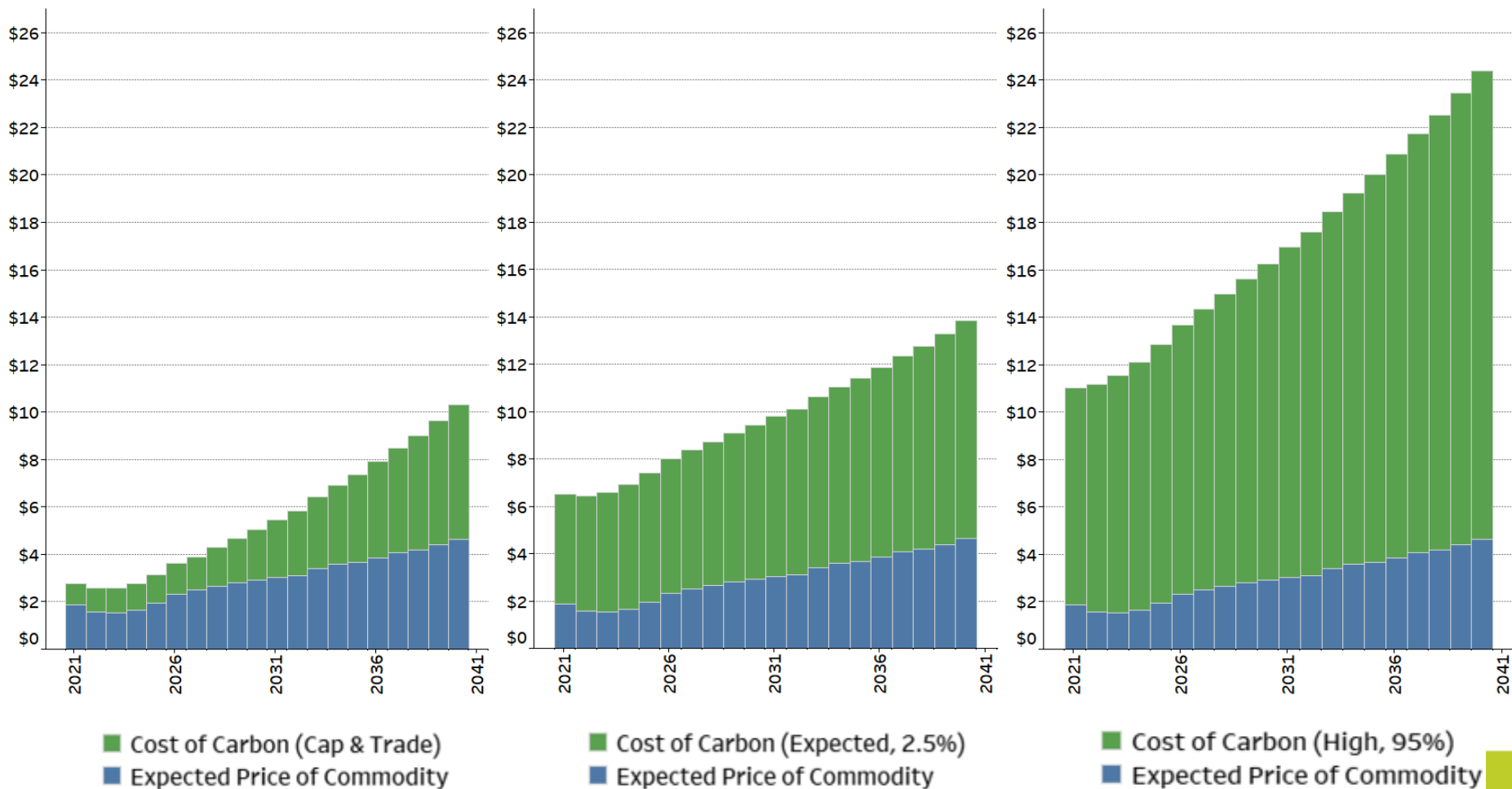

LDC Upstream Emissions

	Avista Specific Natural Gas	
Combustion	Lbs. GHG/MMBtu	Lbs. CO2e/Mmbtu
CO2	116.88	116.88
CH4	0.0022	0.0748
N2O	0.0022	0.6556
Total Combustion		117.61
Upstream		
CH4	0.313406851	10.66
Total		128.27
Upstream Emissions	Avista's Purchases	Emissions Location
0.77	89.72%	Canada
1.00	10.28%	Rockies
0.79		

→ 34 GWP

*Avista gas purchases

An average of the total volume purchased over the past 5 years by emissions location

Avoided Cost Comparison

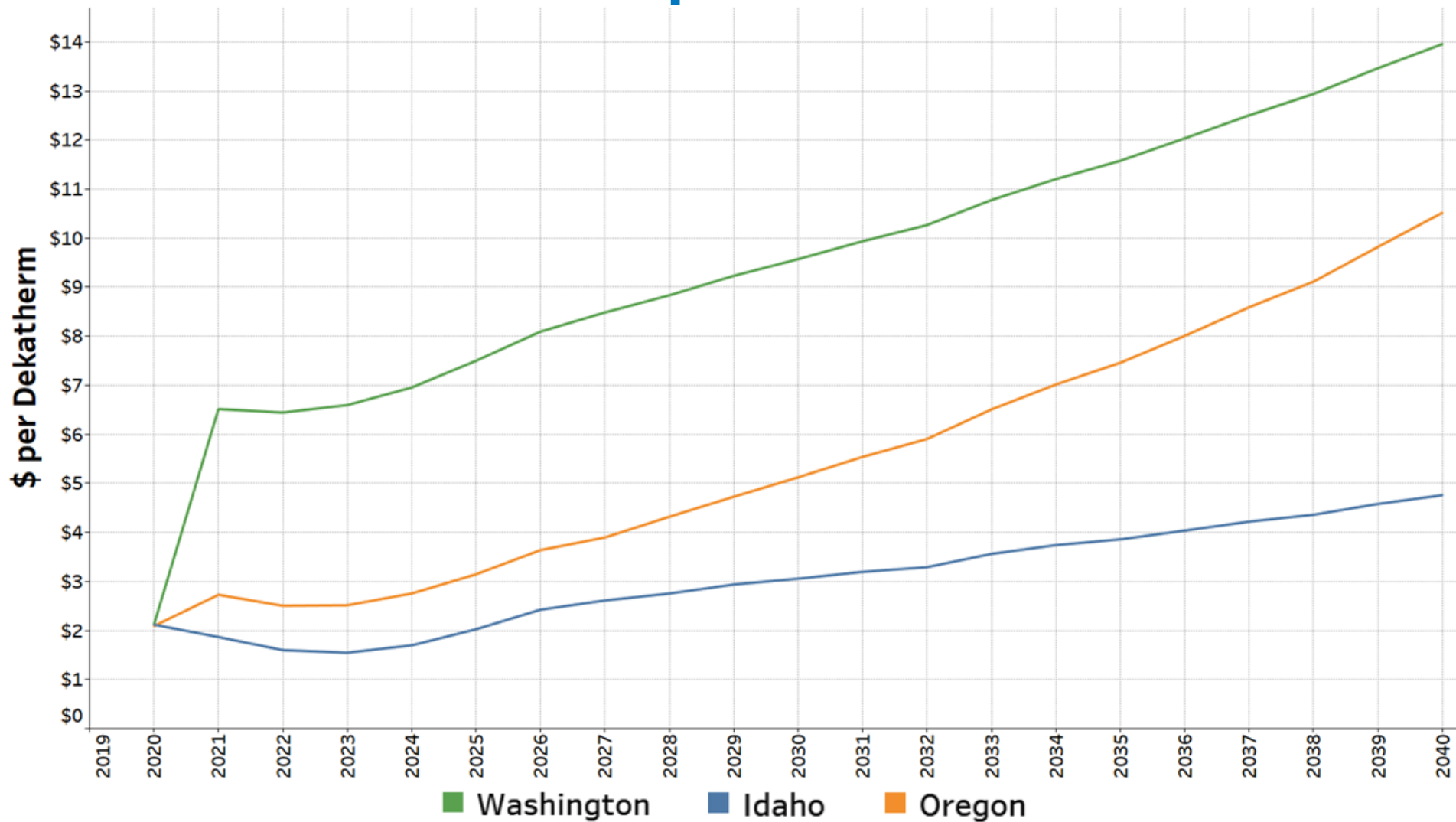

DSM

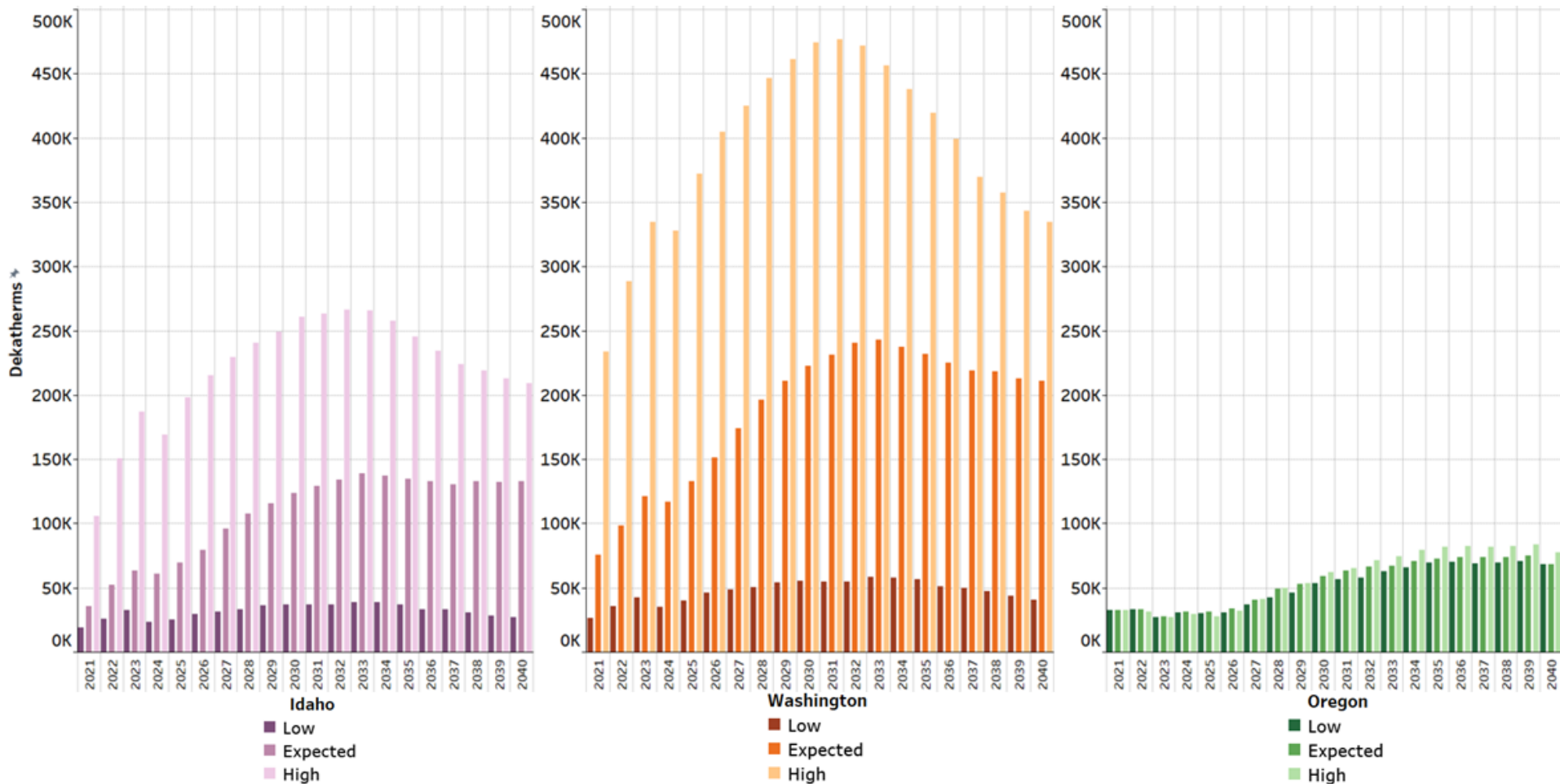



Expected Case

Safe Harbor Statement

This document contains forward-looking statements. Such statements are subject to a variety of risks, uncertainties and other factors, most of which are beyond the Company's control, and many of which could have a significant impact on the Company's operations, results of operations and financial condition, and could cause actual results to differ materially from those anticipated.

For a further discussion of these factors and other important factors, please refer to the Company's reports filed with the Securities and Exchange Commission. The forward-looking statements contained in this document speak only as of the date hereof. The Company undertakes no obligation to update any forward-looking statement or statements to reflect events or circumstances that occur after the date on which such statement is made or to reflect the occurrence of unanticipated events. New risks, uncertainties and other factors emerge from time to time, and it is not possible for management to predict all of such factors, nor can it assess the impact of each such factor on the Company's business or the extent to which any such factor, or combination of factors, may cause actual results to differ materially from those contained in any forward-looking statement.

Proposed Scenarios

Proposed Scenarios	Expected	Average	Low Growth	Carbon Reduction	High Growth
INPUT ASSUMPTIONS	Case	Case	& High Prices		& Low Prices
Customer Growth Rate	Reference Case Cust Growth Rates		Low Growth Rate	Reference Case Cust Growth Rates	High Growth Rate
Use per Customer	3 yr + Price Elasticity				
Demand Side Management	Expected Case CPA		High Prices DSM	Low Prices DSM	
Weather Planning Standard	99% probability of coldest in 30 years	20 year average	99% probability of coldest in 30 years		
GWP	100-Year GWP				
Prices	Expected		High	Low	
Price curve					
Carbon Legislation (\$/Metric Ton)	SCC @ 2.5% WA; Cap and Trade forecast - OR; NO Carbon adder in ID		Carbon Cost - High (SCC 95% at 3%)	SCC @ 2.5% WA; Cap and Trade forecast - OR; NO Carbon adder in ID	
				\$0	

Existing Resources vs. Peak Day Demand

Expected Case – Washington/Idaho (DRAFT)

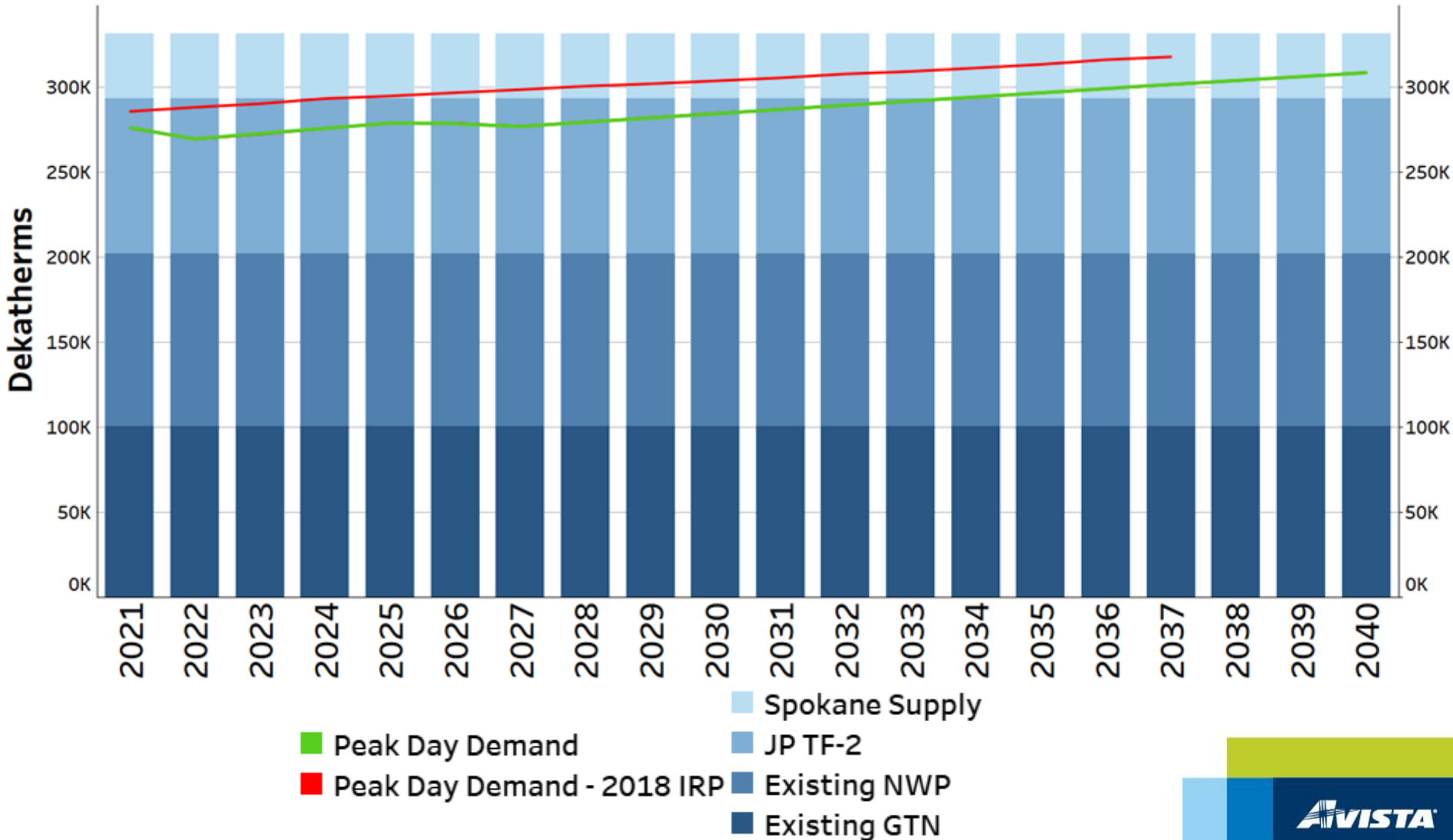

Existing Resources vs. Peak Day Demand

Expected Case – Medford/Roseburg (DRAFT)

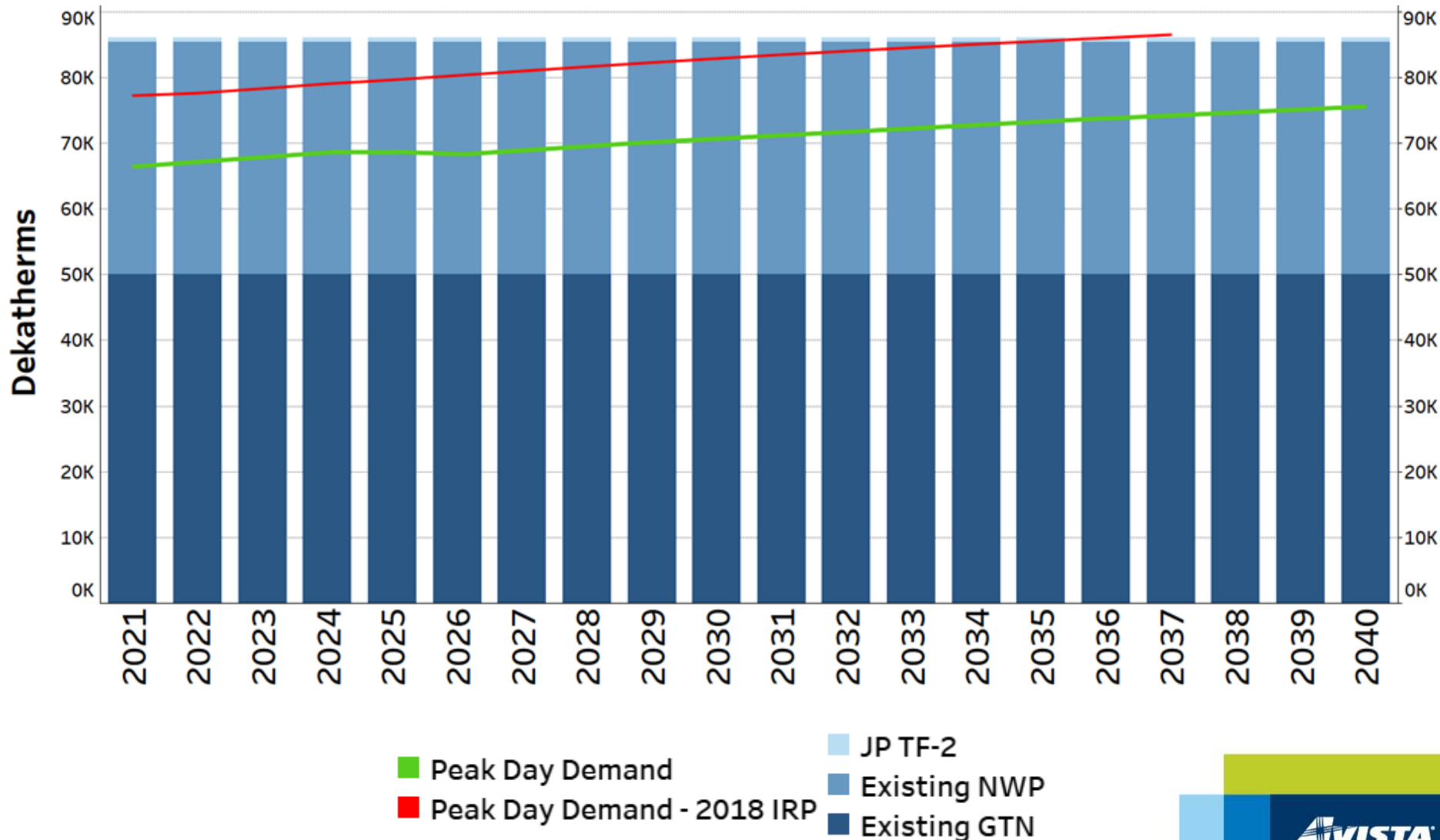

Existing Resources vs. Peak Day Demand

Expected Case – Klamath Falls (DRAFT)

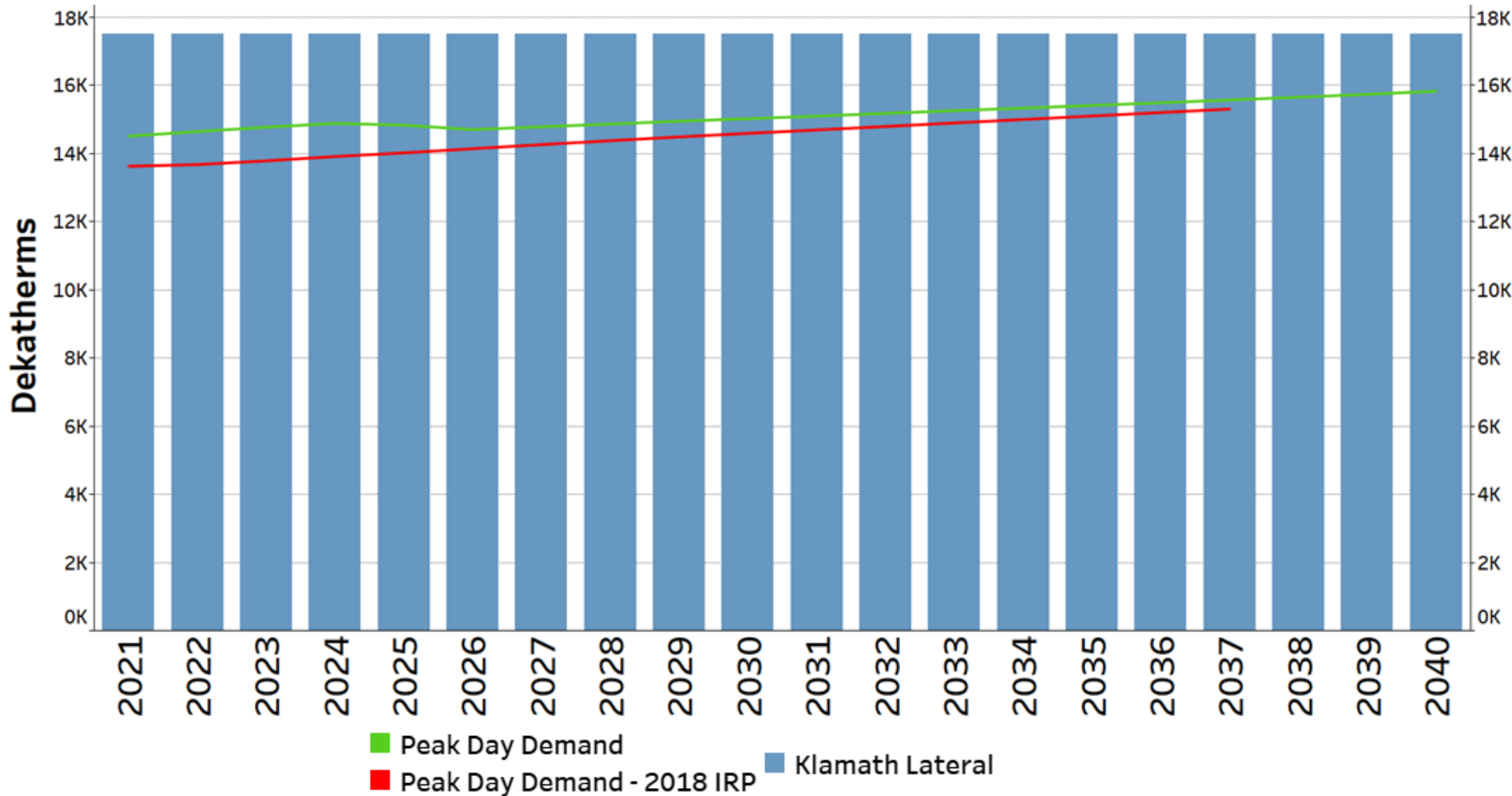

Existing Resources vs. Peak Day Demand

Expected Case – La Grande (DRAFT)

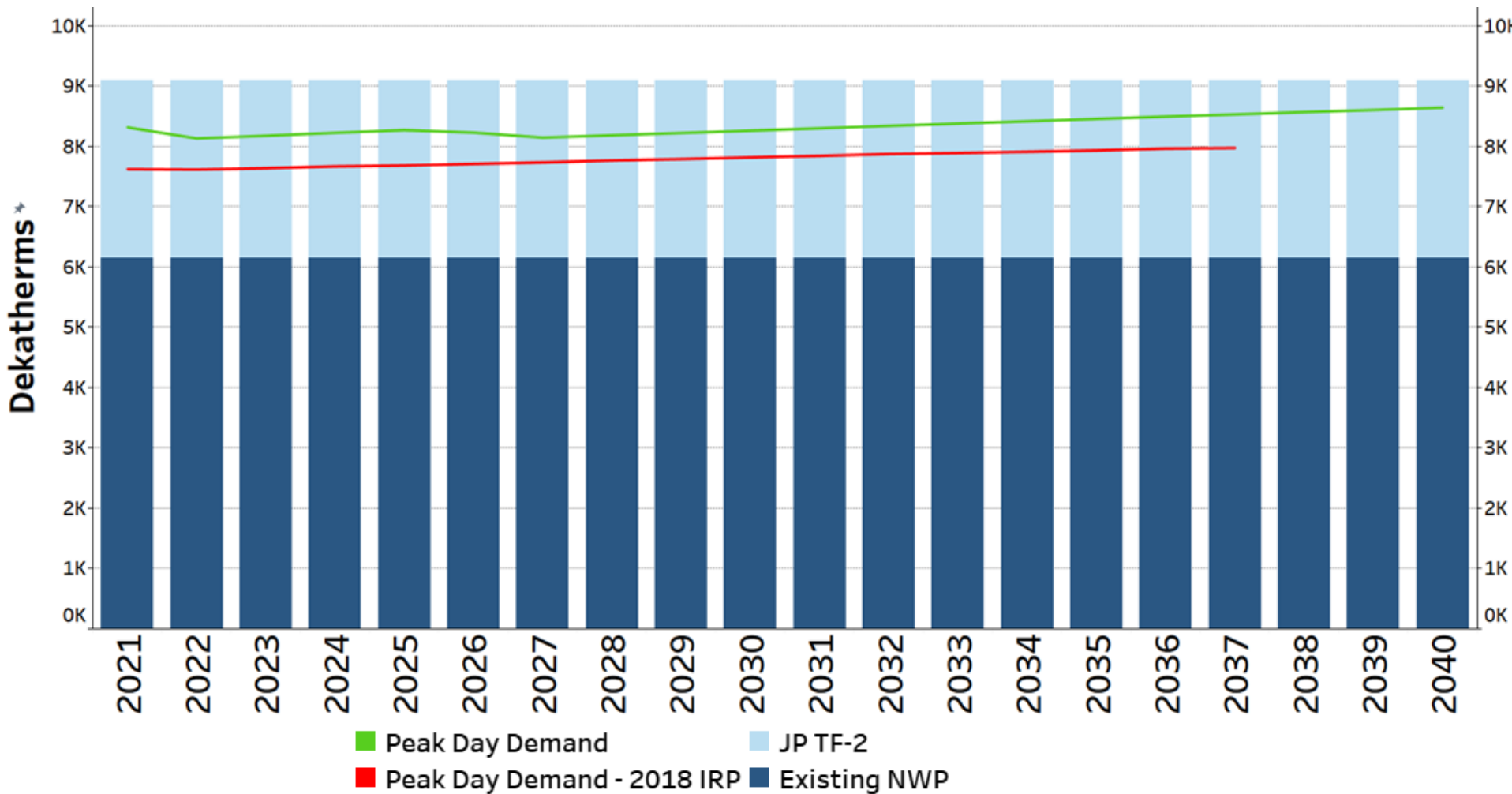

Expected Case - Emissions

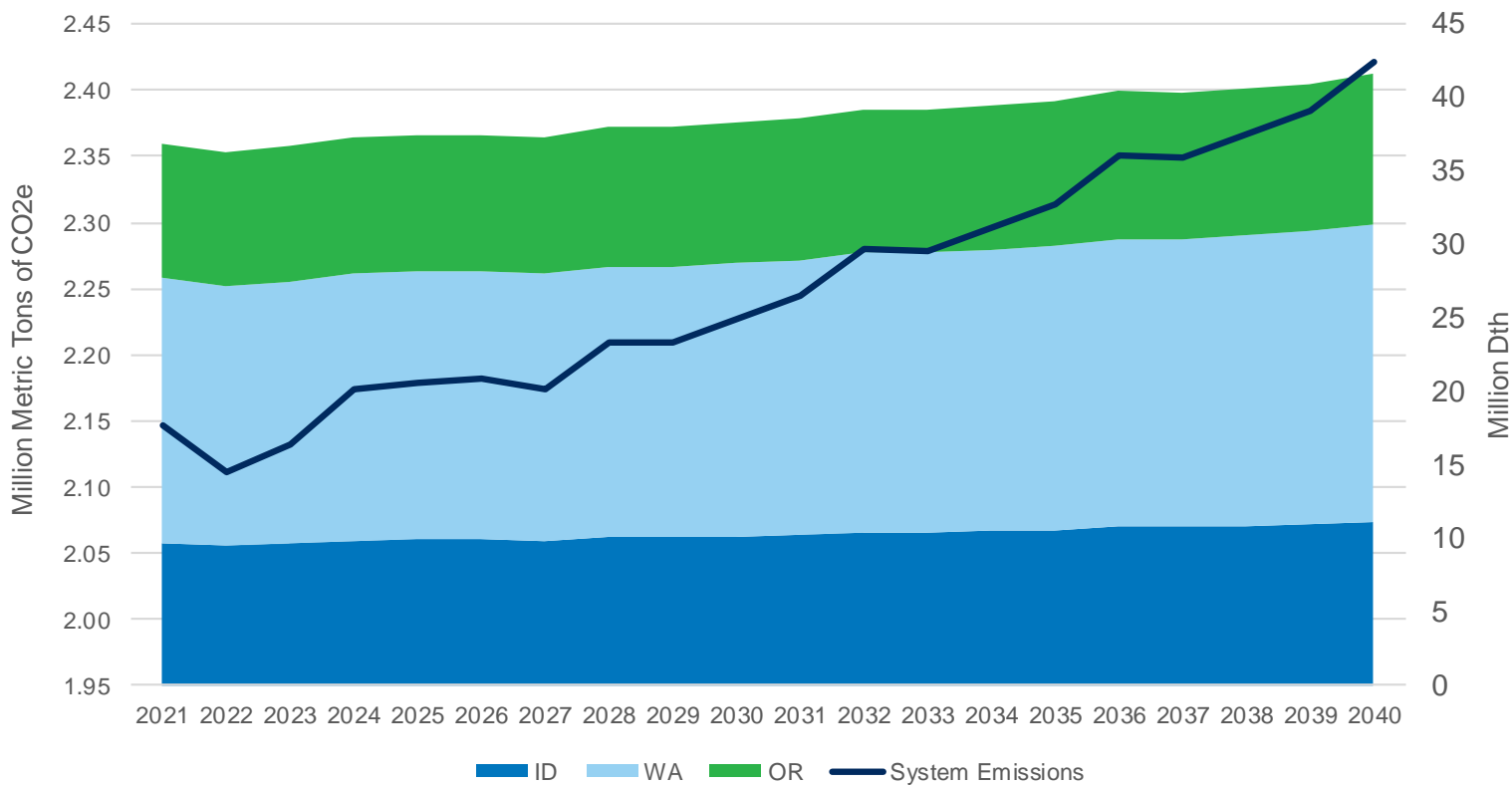

Expected Case Costs

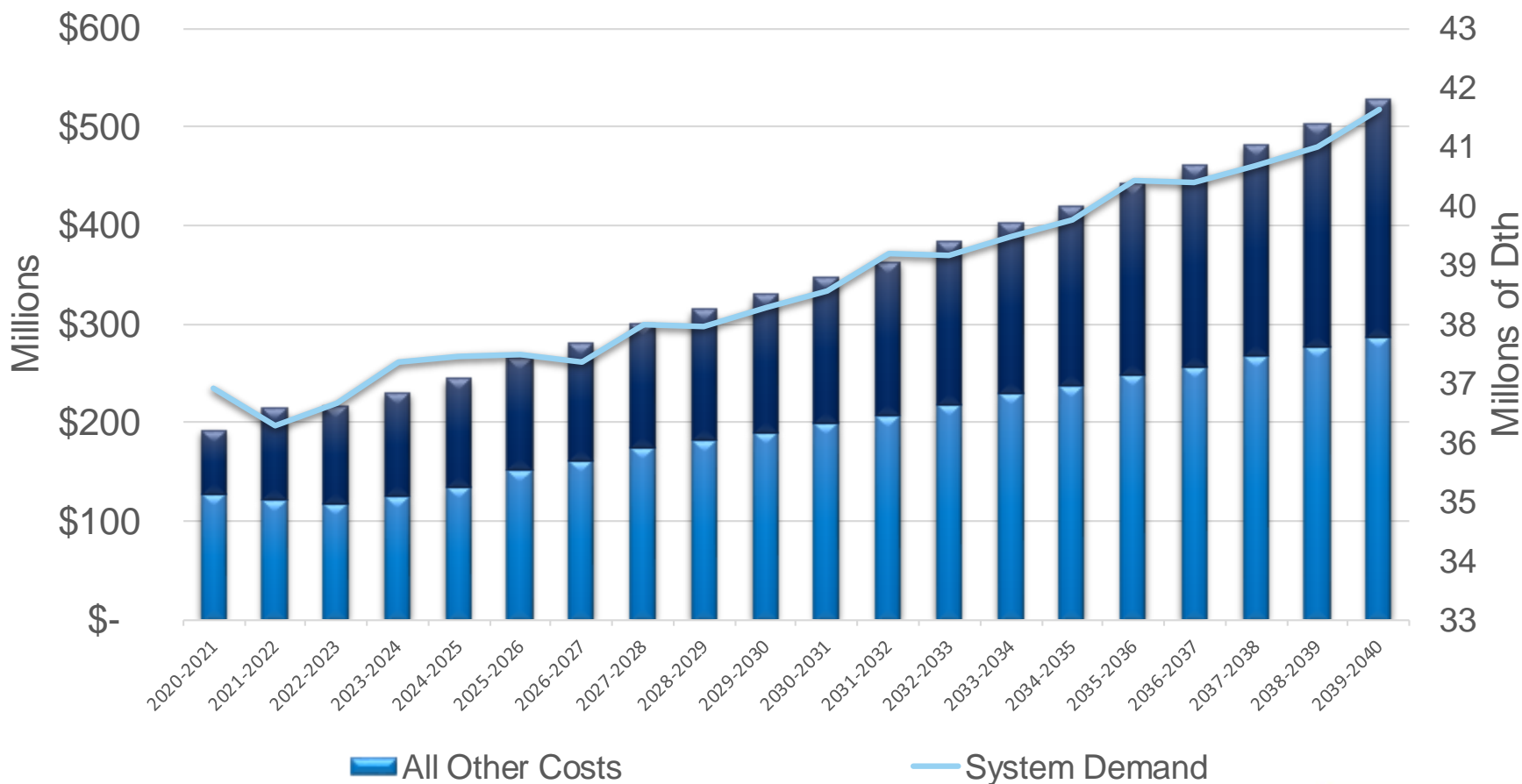

\$3.9B

\$3B



Expected Case distribution

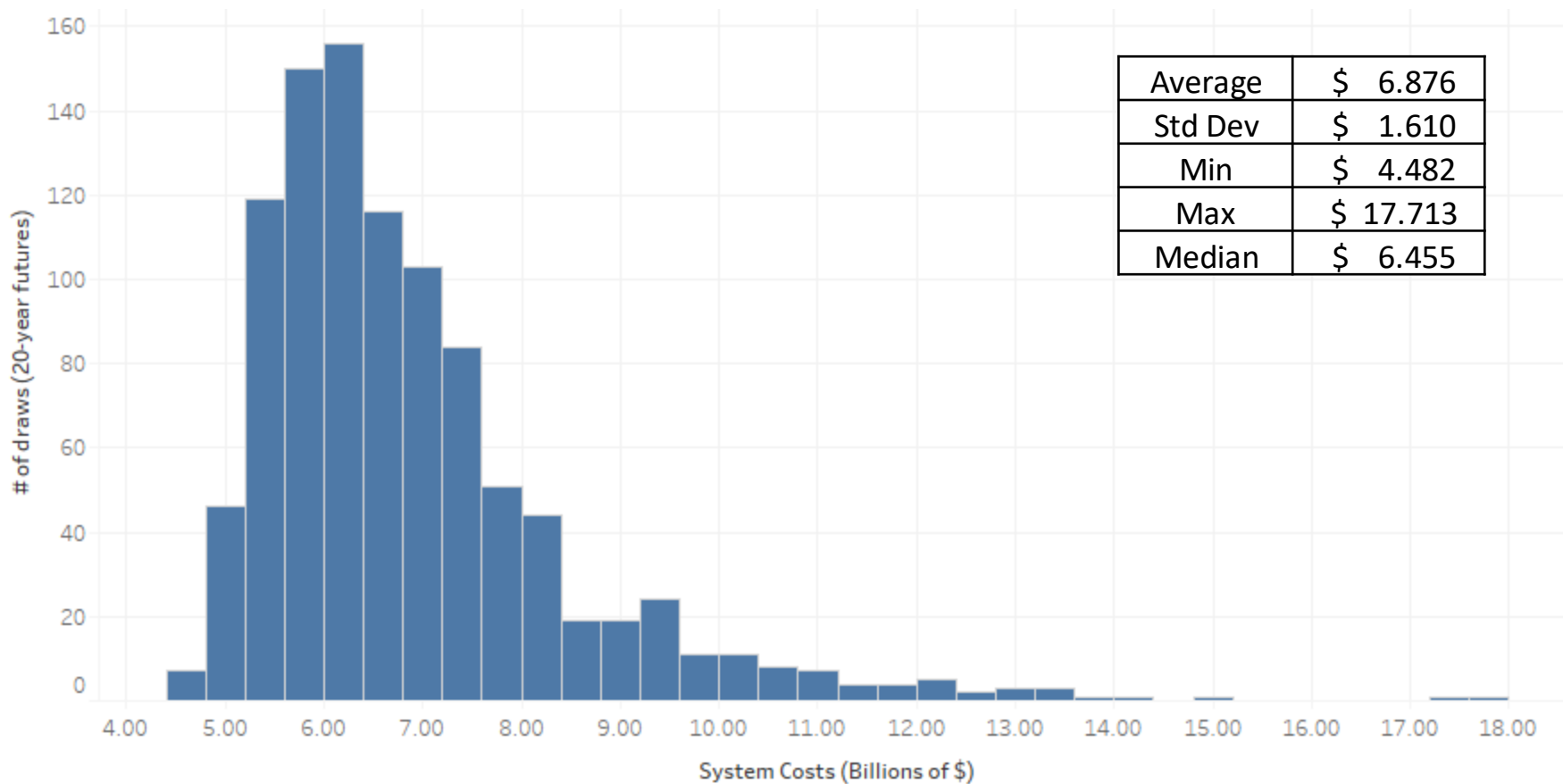

Expected Case 1,000 Draws

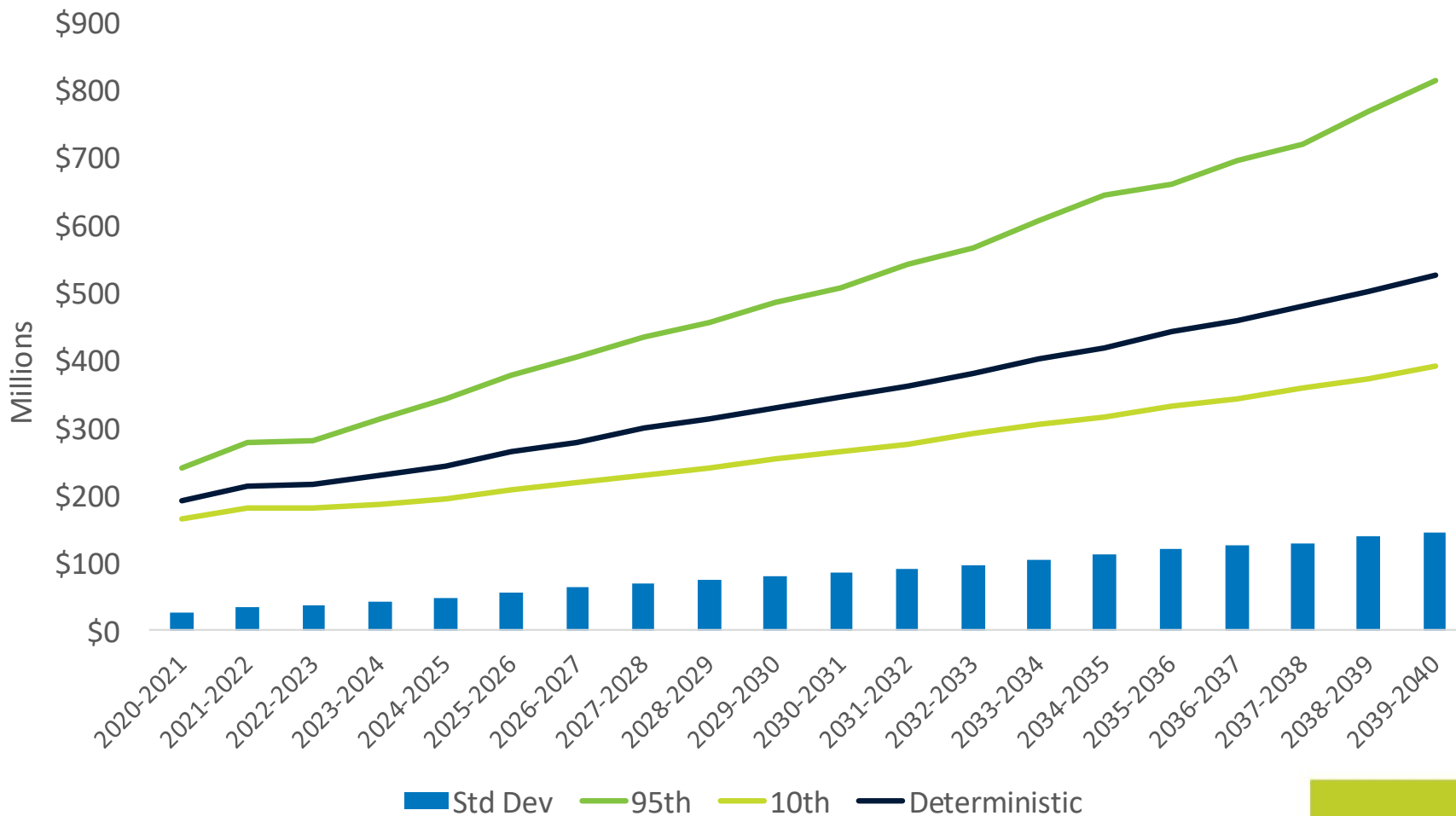



Other Scenarios

Energy Demand



Emissions

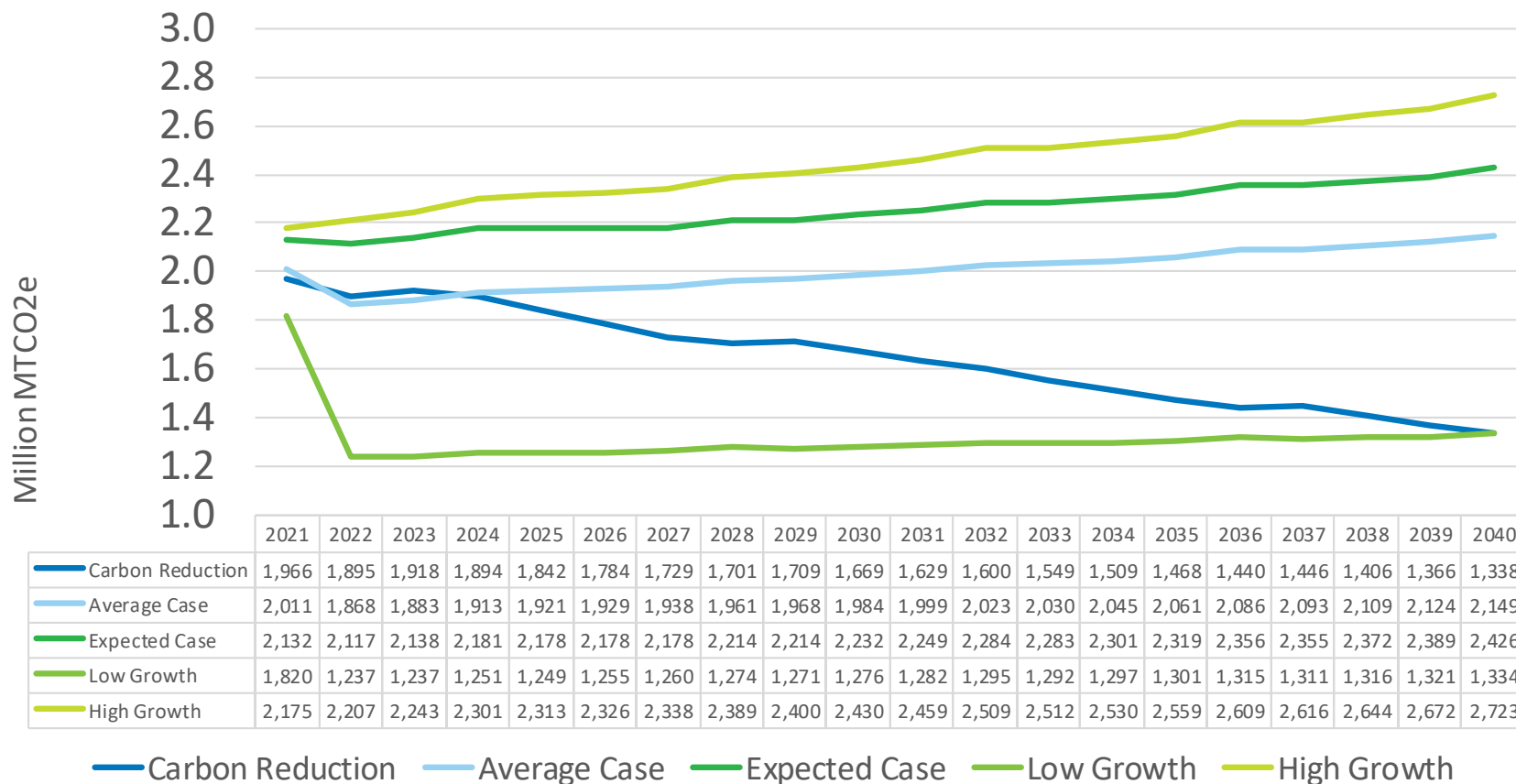

Average Case

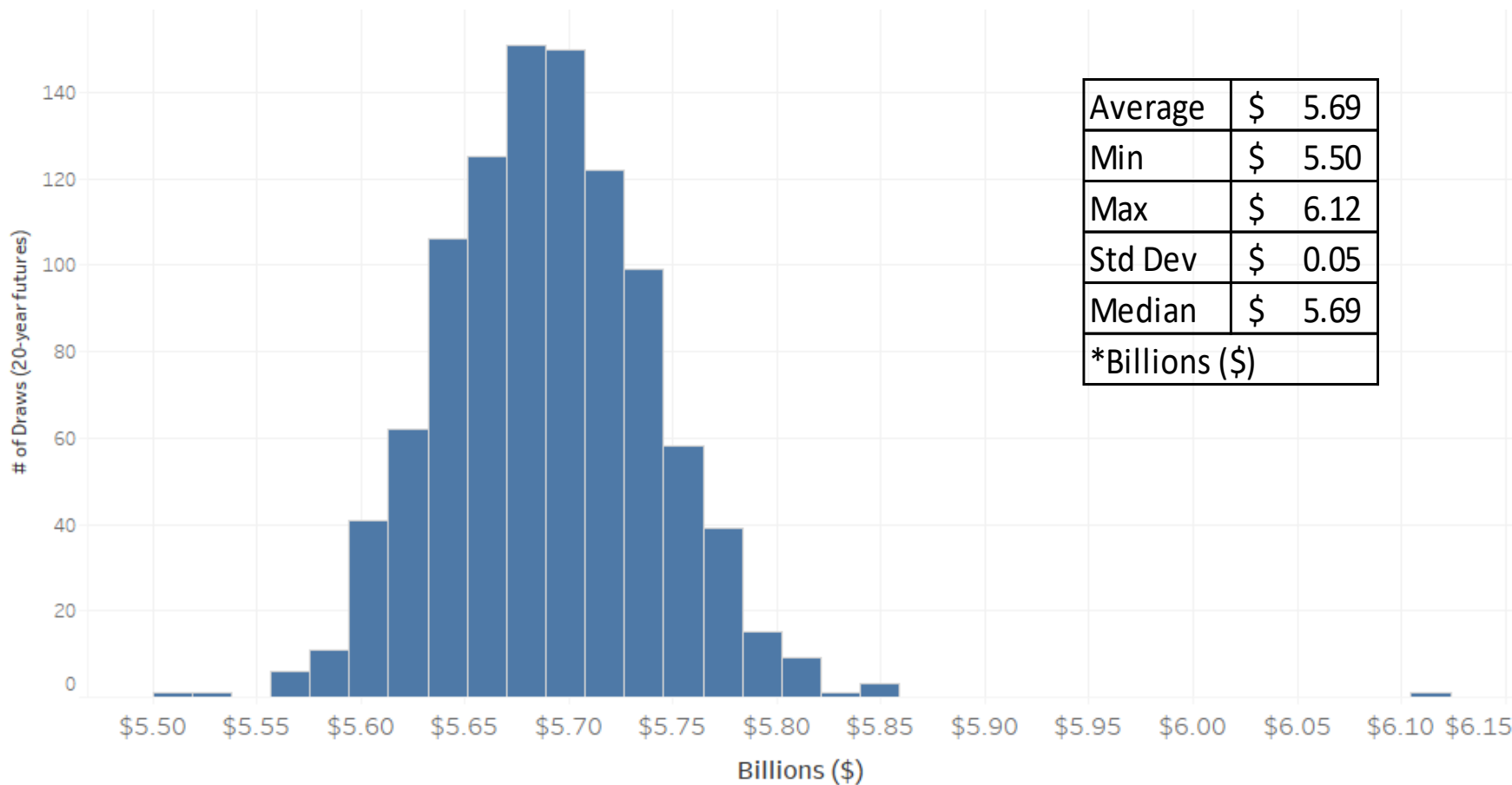

Low Growth and High Prices

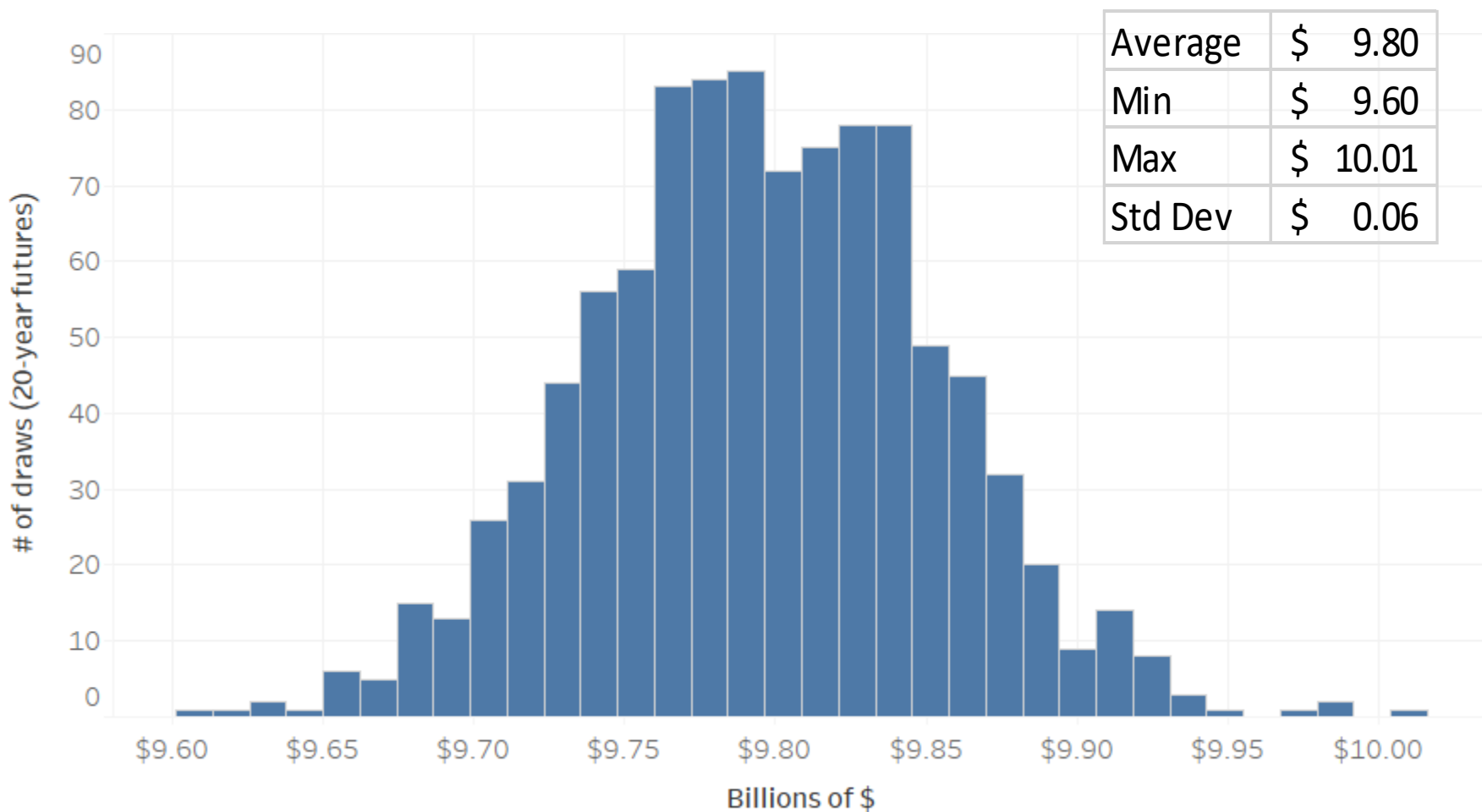

High Growth & Low Prices Least Cost/Risk - RNG solve

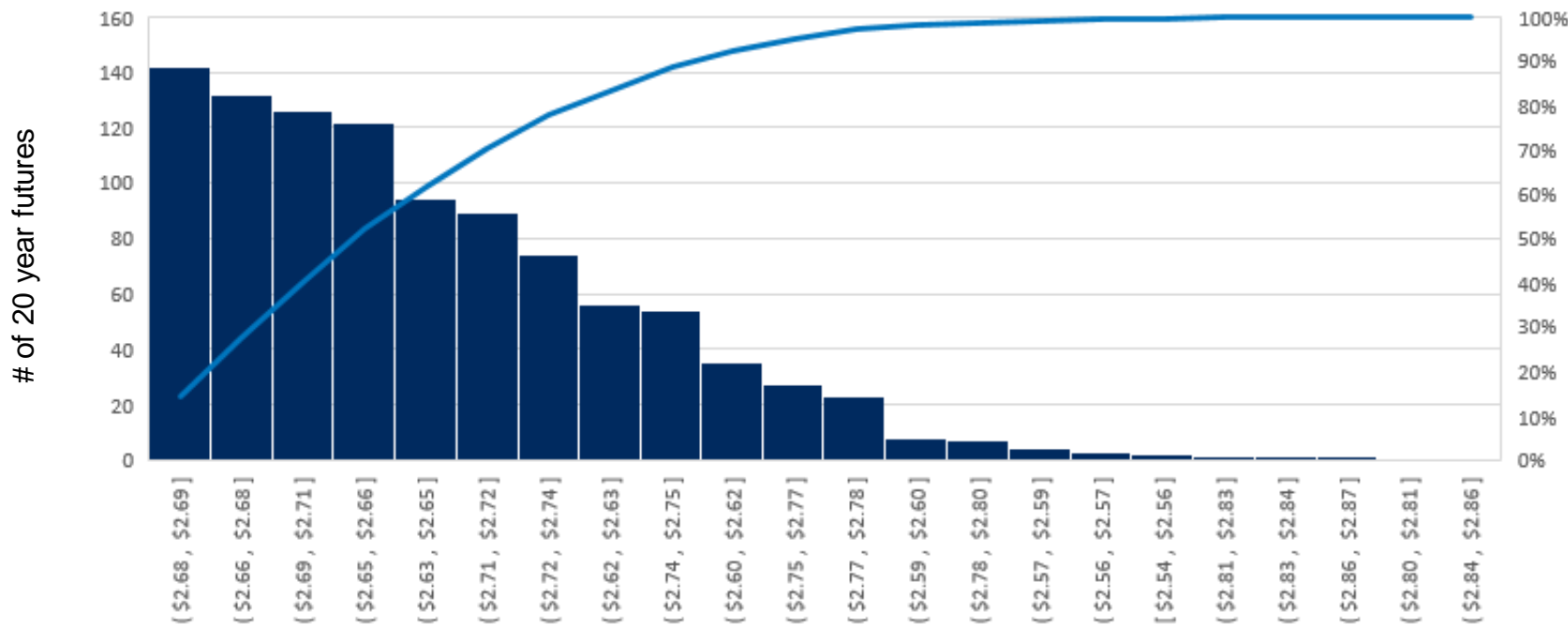

Solve - No Unserved	Average	Stddev	Median	Max	Min
RNG Resources Only	\$ 2.683	\$ 0.043	\$ 2.681	\$ 2.861	\$ 2.542
Plymouth, RNG in La Grande	\$ 2.721	\$ 0.043	\$ 2.719	\$ 2.901	\$ 2.580
GTN - RNG in La Grande	\$ 2.734	\$ 0.042	\$ 2.675	\$ 2.855	\$ 2.540
Medford Lateral Expansion, RNG in La Grande	\$ 2.734	\$ 0.044	\$ 2.731	\$ 2.915	\$ 2.600

*\$ in Billions

**1,000 draws each scenario

Carbon Reduction Scenario

Carbon Reduction scenario

- Carbon reduction goals to meet 2035 targets of 45% below 1990 emissions and criteria are not known
- Any actual availability of physical RNG resources and rate impact by year can be further studied in future Integrated Resource Plans
- Actual projects will be considered on an ad-hoc basis to determine costs and environmental attributes which may make different RNG types a least cost solution
- Exact 1990 emissions are not known and are estimated based on prior 10k's
- Many of the rules from EO 20-04 will be coming out after this IRP is submitted
- Allowances are not considered

Resources Considered

Resource	Dth per year	Levelized Cost Per Dth (Year 1)
Distributed Renewable Hydrogen Production - WA	60,509	\$47.25
Distributed Renewable Hydrogen Production - OR	60,509	\$48.01
Distributed LFG to RNG Production - WA	231,790	\$15.90
Centralized LFG to RNG Production - WA	662,256	\$14.11
Dairy Manure to RNG Production - WA	231,790	\$14.30
Wastewater Sludge to RNG Production - WA	187,245	\$23.34
Food Waste to RNG Production - WA	108,799	\$33.14
Distributed LFG to RNG Production - OR	231,790	\$14.34
Centralized LFG to RNG Production - OR	662,256	\$12.54
Dairy Manure to RNG Production - OR	231,790	\$30.59
Wastewater Sludge to RNG Production - OR	187,245	\$20.36
Food Waste to RNG Production - OR	108,799	\$37.46

*Prices include carbon intensity, carbon costs, capital and overhead, and electricity and are considered Avista owned and operated

**Estimates are from a Black and Veach study

Carbon Intensity

Source	Current Carbon Intensity (g CO ₂ e/MJ)	Percent of estimated Carbon reduction as compared to natural gas (as base value)	lbs. per Dth
Natural Gas	78.37		128.27
Landfill	46.42	41%	75.98
Dairy	-276.24	-452%	(580.40)
WWT	19.34	75%	31.65
Solid Waste	-22.93	-129%	(165.80)

Source: California Air Resources Board

*Green H₂ is considered to have no carbon or -128.27 lbs. per Dth as compared to Natural Gas

Climate Goals

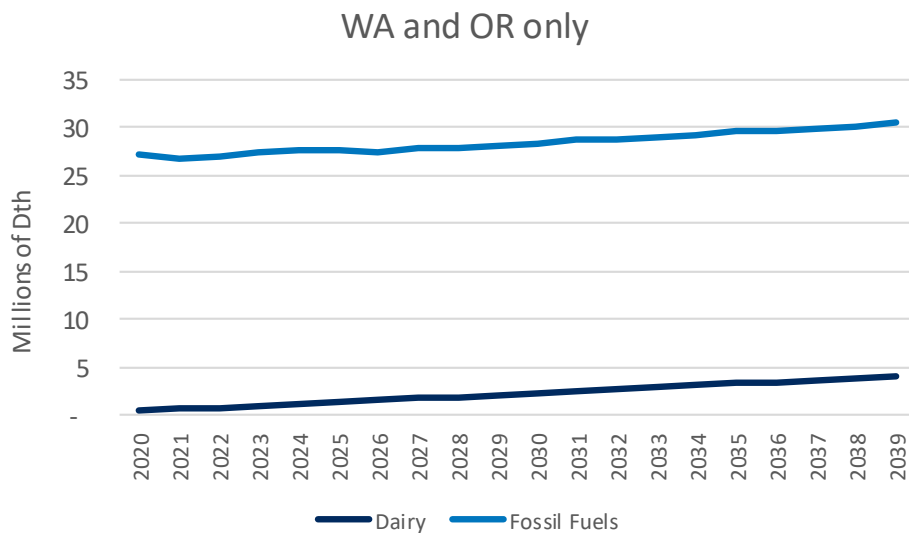
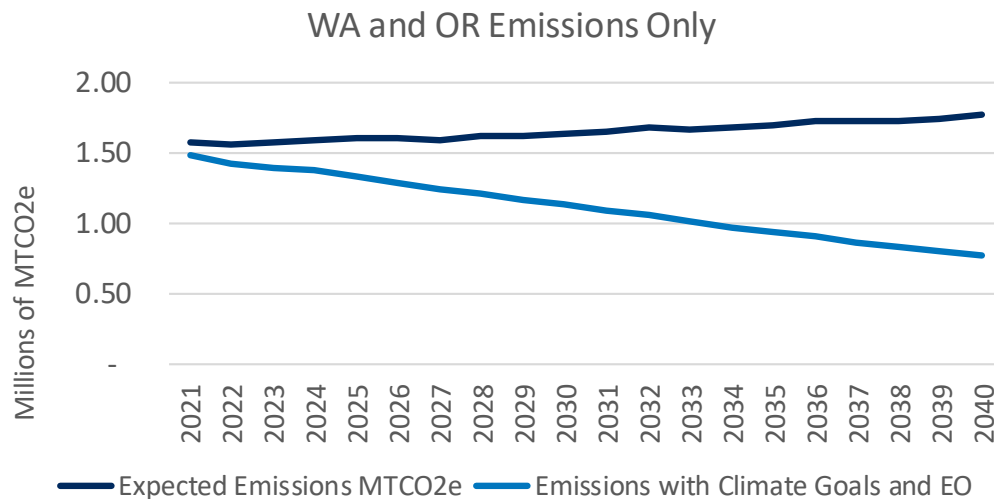

Resources Needed

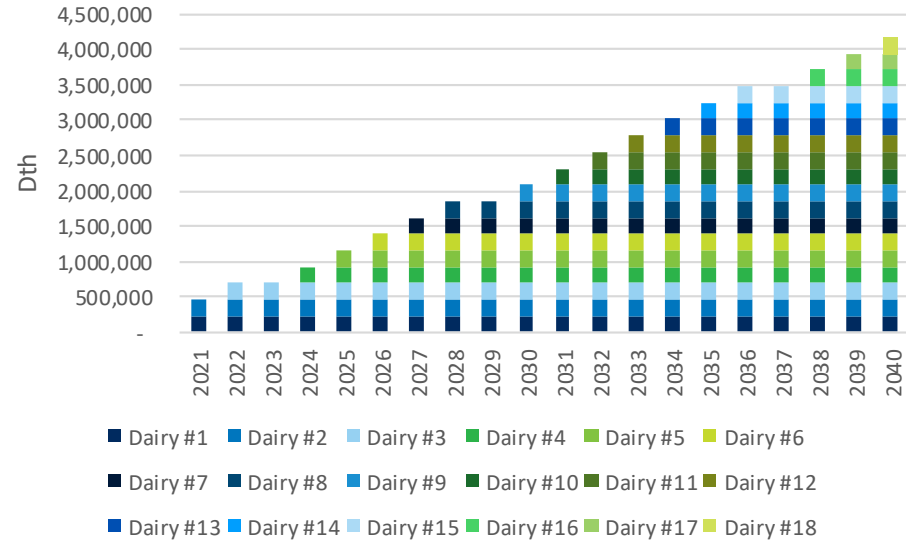

Estimated Dairy Costs

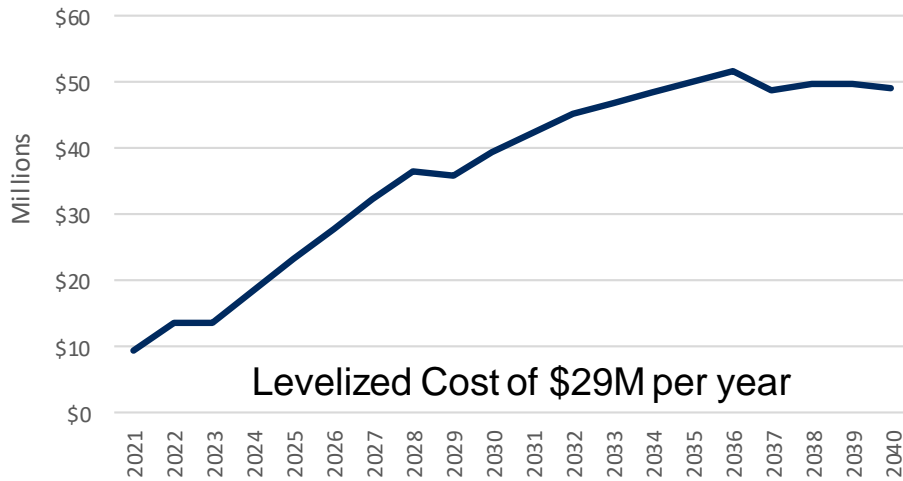

Levelized Cost of \$29M per year

Carbon Reduction

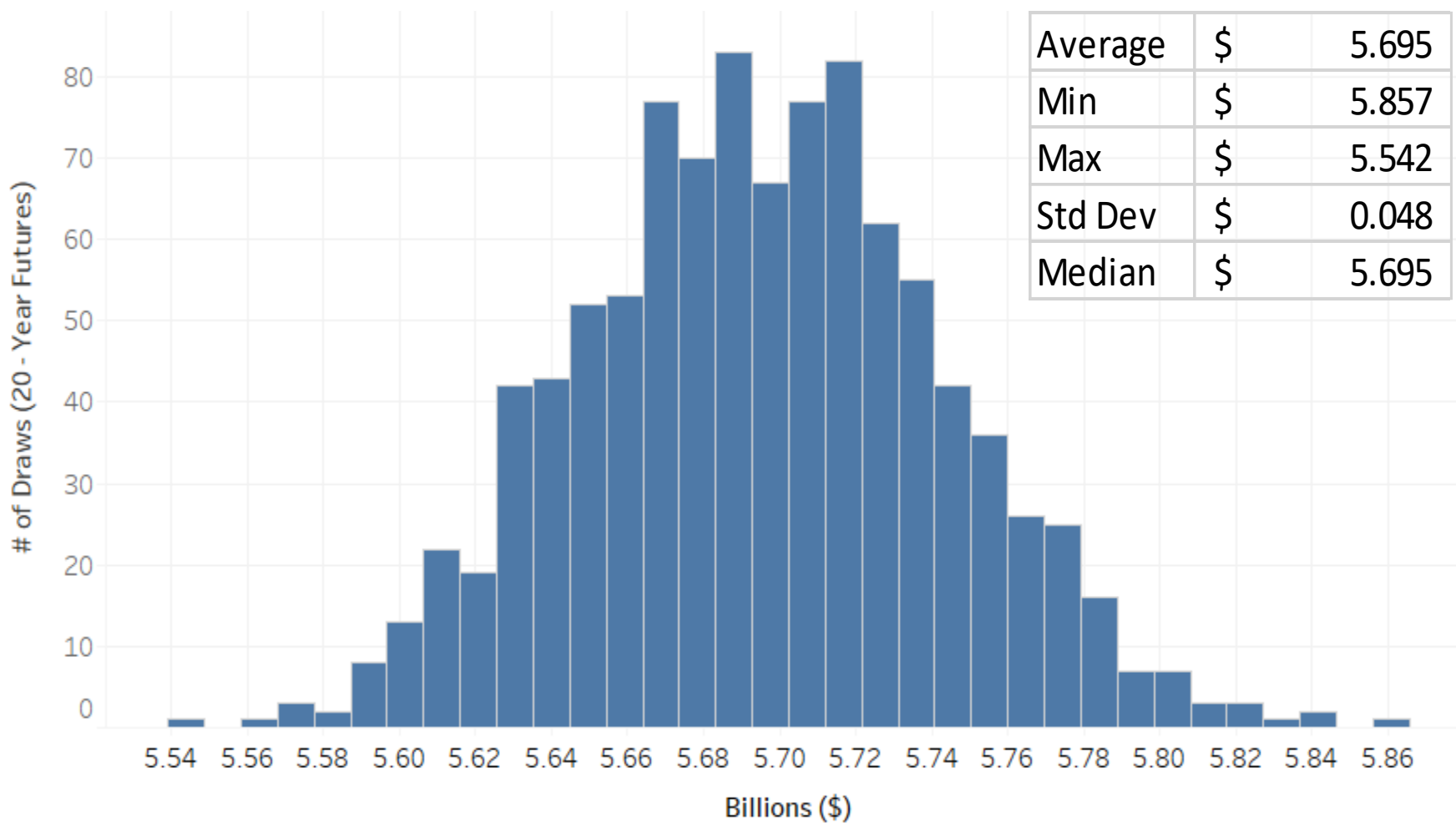

Carbon Reduction Summary

- Dairy
 - With a high carbon intensity and its ability to reduce emissions dairy becomes the preferred resource in this IRP to reduce carbon
 - As the cost of carbon gets higher dairy becomes more economic as the carbon intensity combined with the SCC creates a low price
 - Unlike some other RNG resources a dairy farm has the potential to be reproduced unlike a landfill or waste water treatment plants
- Hydrogen
 - If the high carbon offset of dairy can be mitigated with a lower price of H2 this is both the primary and viable path
 - Green H2 has a large potential to offset emissions and provide the amount of energy demand forecasted
- Carbon offsets through allowances and the associated costs need to be considered to fully understand least cost and least risk
- Other RNG type programs will be modeled at a detailed level as projects are available and depending on costs and offsets could change least cost and least risk solution

Action Plan

- Further model carbon reduction
- Investigate new resource plan modeling software and integrate Avista's system into software to run in parallel with Sendout
- Model all requirements as directed in Executive Order 20-04
- Avista will ensure Energy Trust (ETO) has sufficient funding to acquire therm savings of the amount identified and approved by the Energy Trust Board

Next Steps

2020 Natural Gas IRP Draft Timeline

The following is Avista's tentative 2020 Natural Gas IRP timeline:

- June - November 2020 – Technical Advisory Committee meetings
- December 2020 – Prepare draft of IRP
- January 4, 2021 – Draft of IRP document sent to TAC
- February 1, 2021 – Comments on draft due back to Avista
- February 2021 – TAC final review meeting (if necessary)
- March 2021 – Final editing and printing of IRP
- April 1, 2021 – File IRP submission to Commissions and TAC