

BEFORE THE
WASHINGTON UTILITIES & TRANSPORTATION COMMISSION

UG-__
GENERAL RATE APPLICATION
OF
NORTHWEST NATURAL GAS COMPANY

December 31, 2018

Direct Exhibit of Andrew C. Middleton

ENVIROMENTAL MITIGATION HISTORY

Exh. ACM-3

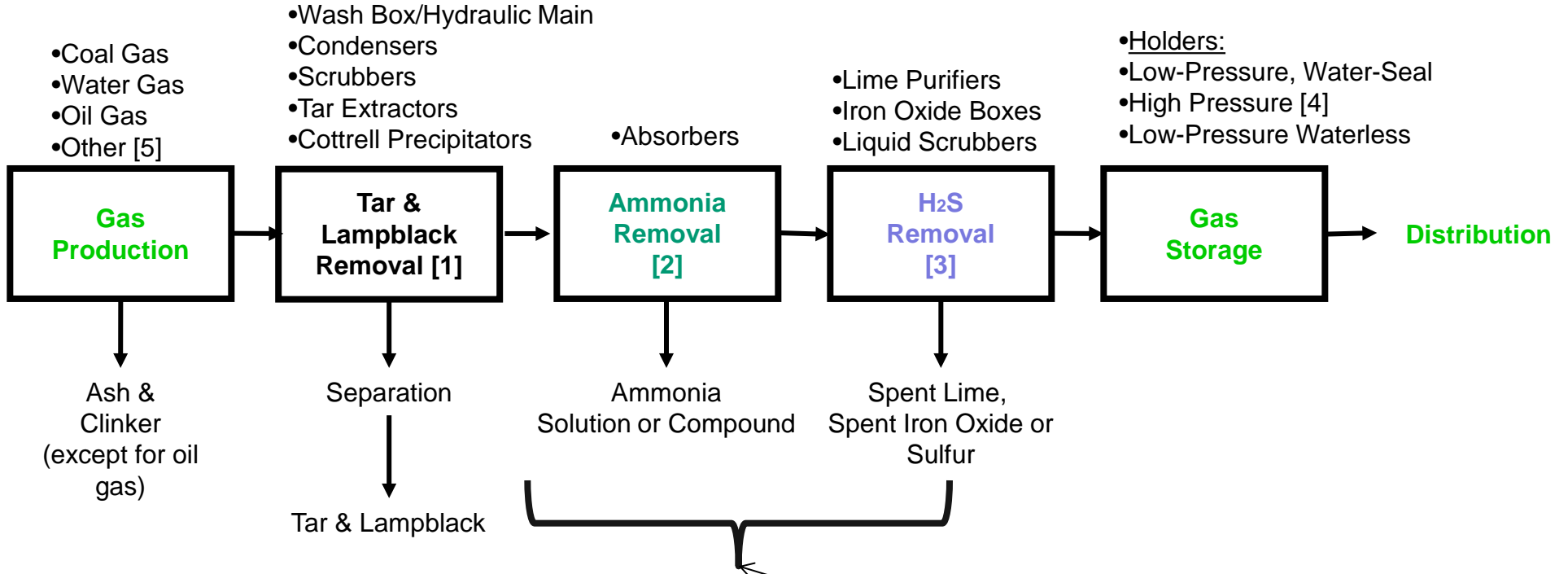

Notes:

[1] Not all of these processes were necessarily at an MGP; water gas included a relief holder in this step to equalize gas flow from cyclical production; lampblack removal was for oil gas manufacture

[2] In coal gas processes only; water gas and oil gas did not typically contain significant ammonia

[3] For coal gas and oil gas using crude oil, cyanide would also be removed here; water gas did not typically contain significant cyanide

[4] Pressurization of manufactured gas generated condensate

[5] Depending on which other process, the gas purification steps may have varied from this diagram

Light Oil and/or Naphthalene recovery might also be incorporated in the gas purification steps depending on the process and scale of gas manufacture.

Exhibit 2: Schematic Diagram of the Overall General Gas Manufacturing, Purification and Storage Processes