

# 2021 Electric Integrated Resource Plan Appendices



# 2021 Electric IRP Appendices

## Table of Contents

### Appendix A – 2021 IRP Technical Advisory Committee Presentations & Meeting Notes

Technical Advisory Committee Meeting 1 Presentations (Page 2)

Technical Advisory Committee Meeting 1 Minutes (Page 84)

Technical Advisory Committee Meeting 2 (Page 97)

Technical Advisory Committee Meeting 2 Minutes (Page 200)

Technical Advisory Committee Meeting 2.5 (Page 215)

Technical Advisory Committee Meeting 2.5 Minutes (Page 261)

Technical Advisory Committee Meeting 3 (Page 270)

Technical Advisory Committee Meeting 3 Minutes (Page 421)

Technical Advisory Committee Meeting 4 (Page 432)

Technical Advisory Committee Meeting 4 Minutes (Page 517)

Technical Advisory Committee Meeting 4.5 (Page 523)

Technical Advisory Committee Meeting 4.5 Minutes (Page 561)

Technical Advisory Committee Meeting 5 (Page 565)

Technical Advisory Committee Meeting 5 Minutes (Page 637)

Public Participation Meeting 6 (Page 645)

### Appendix B – 2021 Electric IRP Work Plan (Page 683)

### Appendix C – Public Participation Comments (Page 689)

### Appendix D – Confidential Historical Generation Operation Data (Page 833)

Appendix E – AEG Conservation & Demand Response Potential Assessment (Page 835)

Appendix F – Avoided Cost Calculations (Page 979)

Appendix G – Transmission 10- year plan (2020) and 2019-2020 Avista System Assessment (Page 985)

Appendix H – New Resource Table for Transmission (Page 1065)

Appendix I – Publicly Available Inputs and Models (Page 1067)

Appendix J – Confidential Inputs and Models (Page 1091)

Appendix K – Load Forecast Supplement (Page 1095)

# 2021 Electric Integrated Resource Plan

## Appendix A – 2021 Technical Advisory Committee Presentations and Meeting Minutes





*2021 Electric Integrated Resource Plan*  
**Technical Advisory Committee Meeting No. 1 Agenda**  
 Thursday, June 18, 2020  
 Virtual Meeting

<b>Topic</b>	<b>Time</b>	<b>Staff</b>
Introductions	9:00	
TAC Expectations and Process Overview	9:05	Lyons
2020 IRP Acknowledgement	9:45	Lyons
Break	10:15	
CETA Rulemaking Update	10:30	Bonfield
Modeling Process Overview	11:00	Gall
Lunch	12:00	
Generation Options	1:00	Hermanson
Break	2:00	
Highly Impacted Communities Discussion	2:15	Gall
Adjourn	3:30	



# 2021 Electric IRP TAC Expectations and Process Overview

John Lyons, Ph.D.  
First Technical Advisory Committee Meeting  
June 18, 2020

# Updated Meeting Guidelines

- IRP team is working remotely, still available by email and phone for questions and comments
- Some processes are taking longer remotely
- Adding stakeholder feedback form to the IRP website – posted with responses
- Researching best way to share other IRP data
- Virtual IRP meetings on Skype until back in the office and able to hold large group meetings
- TAC presentations and notes will still be posted on IRP page

# Virtual TAC Meeting Reminders

- Please mute mics unless speaking or asking a question
- Use the Skype chat box to write out or let us know you have a question or comment
- Respect the pause
- Please try not to speak over the presenter or a speaker who is voicing a question or thought
- Remember to state your name before commenting for the note taker
- This is a public advisory meeting – presentations and comments will be recorded and documented



# Integrated Resource Planning

The Integrated Resource Plan (IRP):

- Required by Idaho and Washington\* every other year
  - Covering timing of 2020 and 2021 IRPs in next presentation
- Guides resource strategy over the next twenty + years
- Current and projected load & resource position
- Resource strategies under different future policies
  - Generation resource choices
  - Conservation / demand response
  - Transmission and distribution integration
  - Avoided costs
- Market and portfolio scenarios for uncertain future events and issues

# Technical Advisory Committee

- The public process piece of the IRP – input on what to study, how to study, and review of assumptions and results
- Wide range of participants involved in all or parts of the process
  - Ask questions
  - Help with soliciting new members
- Open forum while balancing need to get through all of the topics
- Welcome requests for studies or different assumptions.
  - Time or resources may limit the number or type of studies
  - Earlier study requests allow us to be more accommodating
  - **August 1, 2020** is the study request deadline
- Planning team is available by email or phone for questions or comments between the TAC meetings

# 2021 Electric IRP TAC Schedule

- TAC 1: Thursday, June 18, 2020
- TAC 2: Thursday, August 6, 2020 (Joint with Natural Gas TAC)
- TAC 3: Tuesday, September 29, 2020
- TAC 4: Tuesday, November 17, 2020
- TAC 5: Thursday, January 21, 2021
- Public Outreach Meeting: February 2021
- TAC agendas, presentations and meeting minutes available at: <https://myavista.com/about-us/integrated-resource-planning>

# 2021 IRP Key Dates – Work Plan

- Identify Avista's supply resource options – May 2020
- Finalize natural gas price forecast – June 2020
- Finalize demand response options – July 2020
- Finalize energy efficiency options – July 2020
- Update and finalize energy and peak forecast – July 2020
- Finalize electric price forecast – August 2020
- Transmission and distribution studies due – August 2020
- Determine portfolio and market future studies – August 2020
- Due date for TAC study requests – August 1, 2020
- Finalize PRiSM model assumptions – September 2020
- Simulate market scenarios in Aurora – September 2020
- Portfolio analysis and reliability analysis – October 2020
- Present portfolio analysis to TAC – November 2020

# 2021 IRP Public Data Release Schedule

- Supply Side Resource Options – June 2020
- Conservation Potential Study Data – July 2020
- Demand Response Potential Study Data – July 2020
- Peak & energy Load Forecast – July 2020
- Wholesale Natural Gas Price Forecast – August 2020
- Wholesale Electric Price Forecast – September 2020
- Transmission Interconnect Costs – September 2020
- Existing Resource Data – September 2020
- Annual Capacity Needs Assessment – November 2020

# 2021 IRP Key Document Dates

- Filed 2021 IRP Work Plan April 1, 2020
- Internal IRP draft released at Avista on December 4, 2020
- External draft released to the TAC on January 4, 2021
- Comments and edits from TAC due on March 1, 2021
- Final editing and printing – March 2020
- Final IRP submission to Commissions and TAC on April 1, 2021

# Today's TAC Agenda

9:00 – Introductions

9:05 – TAC Expectations and Process Overview, Lyons

9:45 – IRP Acknowledgement, Lyons

10:15 – Break

10:30 – CETA Rulemaking Update, Bonfield

11:00 – Modeling Process Overview, Gall

Noon – Lunch

1:00 – Generation Options, Hermanson

2:00 – Break

2:15 – Highly Impacted Communities Discussion, Gall

3:30 – Adjourn



# 2020 Electric IRP Acknowledgement Update

John Lyons, Ph.D.  
First Technical Advisory Committee Meeting  
June 18, 2020



# Normal Acknowledgement Process

- Avista's electric IRP previously submitted to Idaho and Washington Commissions every other August in odd years
- Commissions set periods for public comments and meetings
- Acknowledgements issued detailing IRP outcomes, comments and expectations for the next IRP
- Normally, we provide details about the acknowledgments in this meeting

# How The IRP Changed

- Expectations and passage of the Clean Energy Transformation Act (CETA) in 2019 led to six month IRP extensions
  - February 28, 2020 in Idaho in AVU-E-19-01 Order No. 34312
  - Washington further extended until April 1, 2021
  - Two IRPs in two years

# Idaho

- AVU-E-19-01 (<https://puc.idaho.gov/case/Details/3633>)
- Requests from the Mayor of Sandpoint, Idaho, Idaho Forest Group, Idaho Conservation League and Embodied Virtue for the IPUC to hold a public hearing in North Idaho
- IPUC set a deadline of August 19, 2020 for public comments about the IRP with Avista replies due September 2, 2020
- Will update the TAC on future comments and acknowledgement
- Ongoing discussions with Commission Staff and ICL concerning several aspects about modeling, Colstrip and the impact of CETA on Idaho customers

# Washington

- Submitted the 2020 IRP to the Washington UTC
- Washington Commission temporarily suspended issuing IRP acknowledgement letters in UE-180738 Order 02 until December 31, 2020
- Progress filed report filed on October 25, 2019 to accommodate CETA rulemaking
  - Commission cannot legally acknowledge an IRP without meeting certain CETA guidelines which still need to have rulemaking completed
- Next draft electric IRP must be submitted by January 4, 2021 and final 2021 electric IRP must be submitted by April 1, 2021
- No specific requirements or expectations from an acknowledgment letter from the 2020 IRP

# Washington

- 2021 IRP expectations are going to focus on the results of CETA rulemaking

Some Washington UTC requests on the work plan include:

- Provide opportunity for stakeholder input on the CPA before finalizing the options
- How equity issues required under CETA will be incorporated in the IRP (TAC 1 and TAC 2)
- Extending participation beyond the TAC through some form of public outreach at a higher level before the end of the IRP process (February 2021)
- Concerns over draft CEIP being included in the IRP
- Provide a general outline of when Avista will provide data or files for stakeholder review and comment deadlines (first presentation today)

# DRAFT



# Clean Energy Transformation Act (CETA)

## Overview and Implementation Status

Shawn Bonfield, Sr. Manager Regulatory Policy & Strategy  
First Technical Advisory Committee Meeting  
June 18, 2020

# CETA: A Brief Overview

- Senate Bill 5116 – passed by legislature in 2019
- Applies to all electric utilities in WA and sets specific milestones to reach required 100% clean electric supply
- By 2025 – eliminate coal-fired resources from serving WA customers
- By 2030 – electric supply must be greenhouse gas neutral,
- By 2045 – electric supply must be 100% renewable or be generated from zero-carbon resources

## Washington Greenhouse Gas Emissions

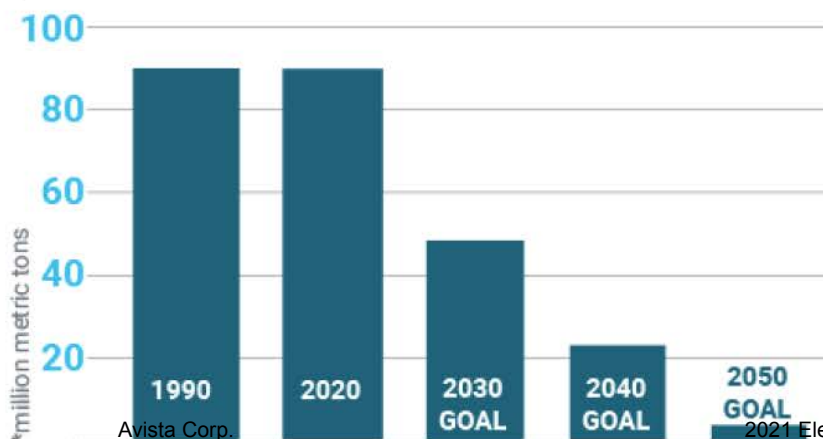

## Washington Clean Energy Transformation Act



# CETA: Additional Details

## Utilities must:

- Ensure the equitable distribution of energy and nonenergy benefits and reduction of burdens to vulnerable populations and highly impacted communities
- Ensure long-term and short-term public health and environmental benefits and reduction of costs and risks
- Ensure energy security and resiliency
- Make progress toward and meet the standards of the law:
  - While maintaining and protecting the safety, reliable operation, and balancing of the electric system
  - At the lowest reasonable cost



EQUALITY



EQUITY



Energy Independence Act (2006)

Clean Energy Transformation Act (2019)

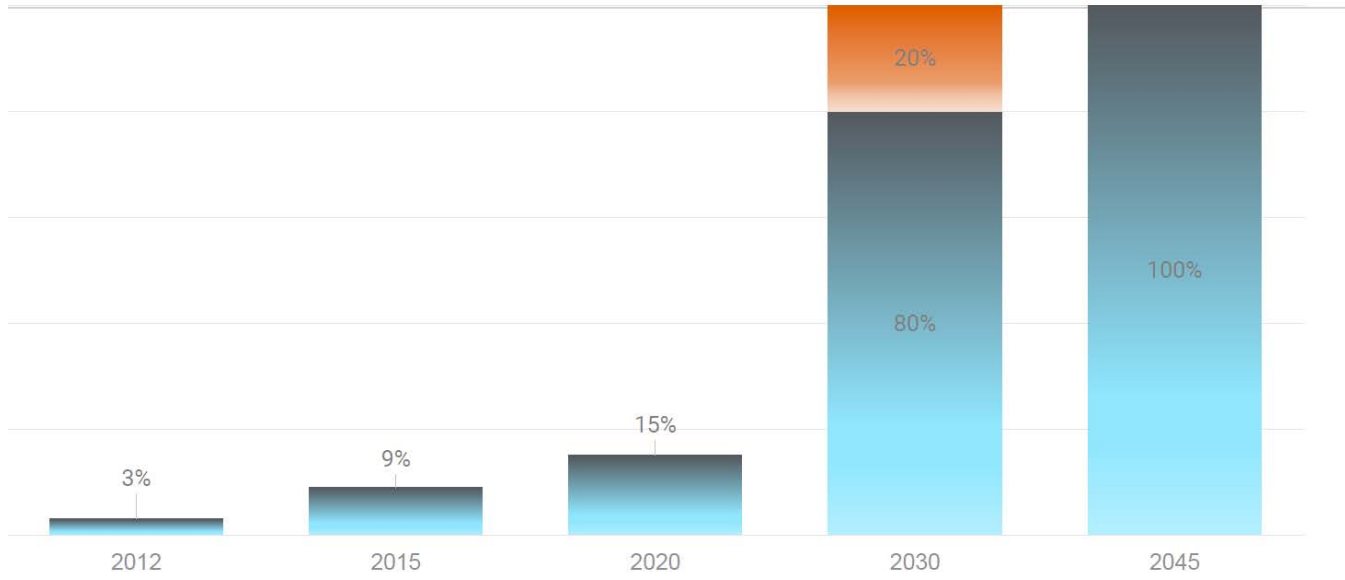

# WA utilities' existing resource mix

Source: WA Department of Commerce

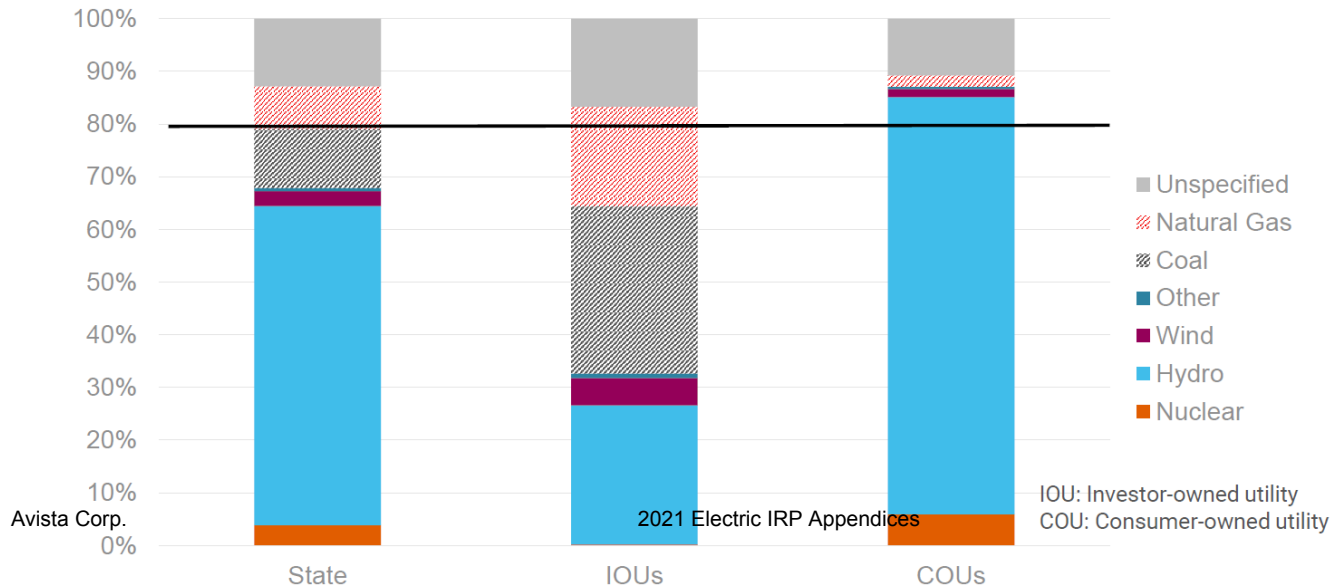

# Key dates

Dec 2020	Agencies complete initial rules
Jan 2022	Utilities submit 1 <sup>st</sup> clean energy implementation plans (2022-2025)
Jun 2022	Agency rules on market transactions and double-counting
Dec 2025	Deadline to remove coal from portfolios
Jan 2026	2 <sup>nd</sup> CEIP submitted (2026-2029)
2030	GHG Neutral standard takes effect
2045	100% Clean Electricity standard takes effect

Source: WA Department of Commerce

# UTC CETA Implementation Plan UE-190485 (Closed)

- Phase 0 – overall implementation plan
  - Process timeline and scope of issues
- Phase I - August 2019 to January 1, 2021
  - Elements that must be complete by January 1, 2021 as required by Section 10 of SB 5116
  - Publish the social cost of carbon on UTC's website by September 15, 2019
  - Initiate dockets for various rulemakings relating to CETA implementation
- Phase II – January 1, 2021 to June 30, 2022
  - Rulemakings with deadlines after January 1, 2021
  - Amend IRP rules to incorporate Cumulative Impact Analysis
  - Carbon and Electricity Markets Rulemaking

# Social Cost of Carbon

## U-190730 (Closed)

- New section added to chapter 80.28 RCW, outlining cost of greenhouse gas emissions resulting from the generation of electricity and use of natural gas, the UTC must adjust the social cost of carbon to reflect the effect of inflation.
- Social Cost of Carbon published on UTC website in September 2019:
  - <https://www.utc.wa.gov/regulatedIndustries/utilities/Pages/SocialCostofCarbon.aspx>

# Energy Independence Act (EIA) Rulemaking – UE-190652

- E2SSB 5116: Amending WAC 480-109, Energy Independence Act (EIA) rules
  - a. Streamline E2SSB 5116 with EIA rules. ( § 10(3))
  - b. Discuss equitable distribution of benefits.
  - c. Discuss low-income definition, if needed. ( § 2(25))
  - d. Discuss energy assistance need definition, if needed. ( § 2(16))
  - e. Consider incorporating low-income energy efficiency target.
  - f. Incorporate updates to hydro eligibility and tracking. ( § § 28 and 29)

**Status: Written comments due on draft rules July 6<sup>th</sup>. Rule adoption hearing set for July 28<sup>th</sup>.**

# Clean Energy Implementation Plan (CEIP) Rulemaking UE-191023

- E2SSB 5116: New Chapter, Clean Energy Implementation Plans (CEIPs)
  - a. Provide guidelines for Clean Energy Implementation Plans. ( § 6)
  - b. Discuss equitable distribution of benefits. ( § 4(8))
  - c. Develop incremental cost methodology at the beginning of the rulemaking. ( § 6)
  - d. Address reporting and compliance, and the penalty process. ( § 9(1)(a))

**Status: First draft of rules released May 5, 2020 with comments due June 2, 2020. Second set of draft rules to be released in July timeframe.**

# Electric IRP Updates Rulemaking UE-190698

- E2SSB 5116 and EHB 1126: Amending WAC 480-100-238, Electric Integrated Resource Plans (IRP)
  - a. Update inputs to IRPs (e.g., hydro eligibility and tracking; resource adequacy; distributed energy resources principles from EHB 1126; and demand response).
  - b. Update structure of IRPs.
  - c. Update public involvement process.
  - d. Update outputs of IRP Clean Energy Action Plans. ( § 14(2))
  - e. Incorporate the social cost of carbon into IRPs. ( § 14(3)(a))
  - f. Refine the development of avoided costs to reflect E2SSB 5116 and social cost of carbon.
  - g. Develop resource value test based on review of E2SSB 5116 and social cost of carbon.
  - h. Discuss equitable distribution of benefits. ( § 4(8))
  - i. Discuss assessment informed by cumulative impact analysis, as needed. ( § 14(1)(k))
  - j. Amend IRP rules to incorporate the Cumulative Impact Analysis complete by Department of Health workgroup. (ch. 288, § 14(11))
  - k. Incorporate distributed energy resources elements from EHB 1126. (ch. 205, § 1)

**Status: Development and preparation of draft rules ongoing.**

# Purchase of Electricity (PoE) Rulemaking UE-190837

- E2SSB 5116: Amending WAC 480-107, Resource Acquisition (Requests for Proposals, or RFP)
  - a. Incorporate existing work on RFPs from Docket U-161024.
  - b. Ensure that the E2SSB 5116 standard is met in construction and acquisition of property and the provision of electric service. ( § 5)
  - c. Incorporate resource adequacy considerations. ( § 6(2)(a)(iv))
  - d. Discuss equitable distribution of benefits. ( § 6(1)(c)(iii))

**Status: Second round of draft rules issued June 1, 2020 with comments due June 29, 2020.**



# Carbon & Electricity Markets Workgroup

## UE-190760

- E2SSB 5116: With the Department of Commerce, initiate a Carbon and Electricity Markets Workgroup for regular discussions to inform Phase II rulemaking.
- Define requirements for load met with market purchases. (ch. 288, § 13)

**Status: Workgroup to hold four educational workshops to set a base of understanding. Second workshop scheduled for June 10, 2020. Public work sessions to begin in Fall 2020 with rulemaking complete June 30, 2021.**

# Department of Commerce Rulemakings

- Thermal Renewable Energy Credits – applies to all utilities
- Reporting and demonstration of compliance – applies to all utilities
- CEIP for consumer-owned utilities – ensure alignment with UTC rules
- Cost methodology for rate impact – applies to all utilities

Rules effective January 1, 2021

# Department of Ecology Rulemakings

- Ecology is starting rulemaking for Chapter 173-444 WAC, Clean Energy Transformation Rule to implement parts of the Clean Energy Transformation Act assigned to Ecology. The rulemaking will:
  - Establish a process to determine what types of energy transformation projects may be eligible to meet the Clean Energy Transformation Act.
  - Establish a process and requirements to develop standards, methodologies, and procedures to evaluate energy transformation projects.
  - Provide greenhouse gas emission factors for electricity.
- Timeline
  - Spring 2020 – develop and prepare rule language
  - Summer 2020 – public hearing and comment
  - December 2020 – adopt rule
  - January 2021 – rule effective



# 2021 Electric IRP Modeling Process Overview

James Gall, IRP Manager  
First Technical Advisory Committee Meeting  
June 18, 2020

# IRP Planning Models

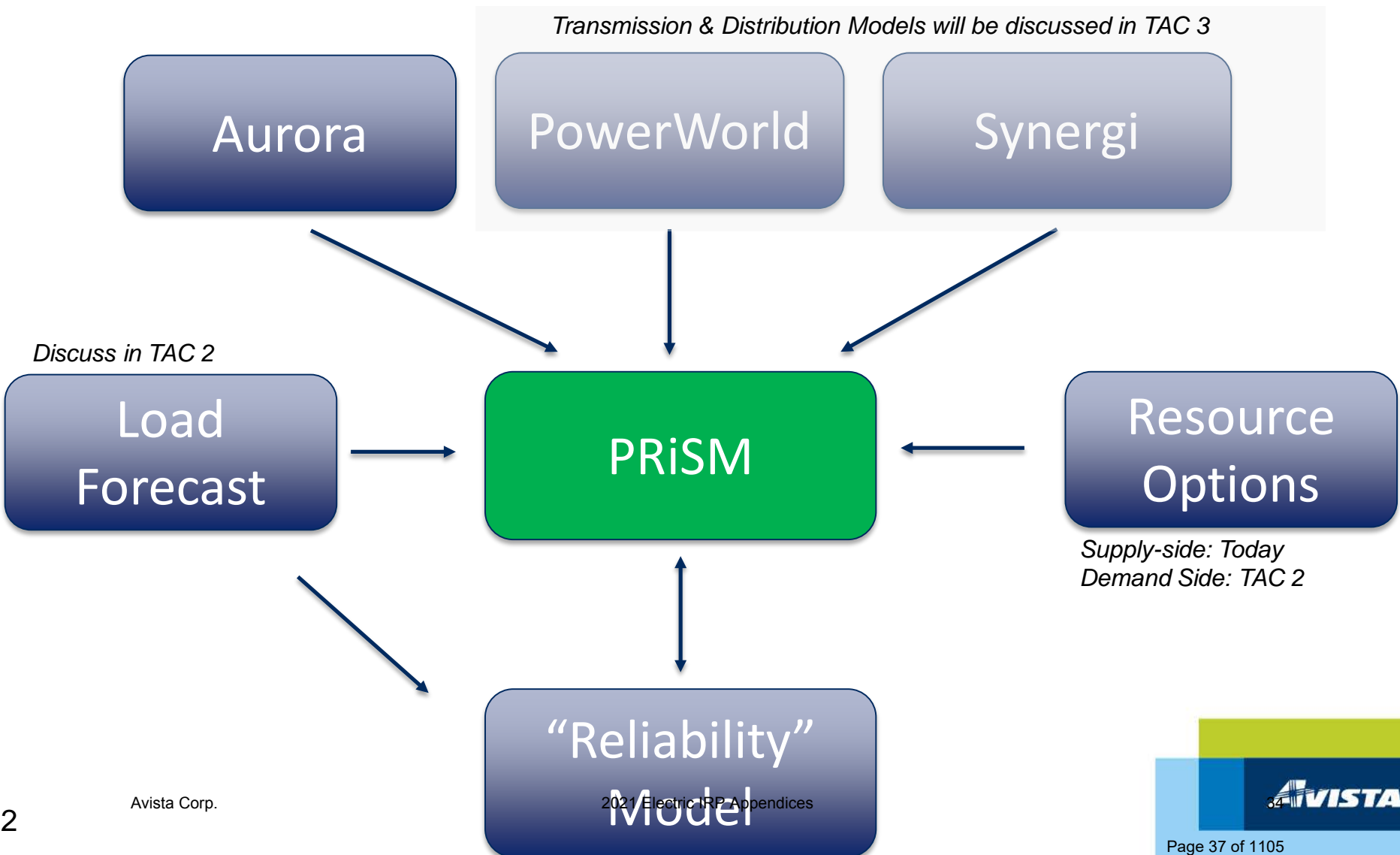

# Aurora



- Electric Market- Production Cost Model
- Developed by Energy Exemplar
- Industry standard and widely used in the Pacific Northwest
- Avista started using software for the 2003 IRP
- Simulates generation dispatch to meet load allowing for system constraints

## Inputs:

- Regional loads\*
- Fuel prices\*
- Fuel availability\*
- Resources (availability\*)
- New resources costs
- Transmission
- System Constraints

## Outputs:

- Market prices
- Energy mix
- Transmission usage
- Emissions
- Power plant margins, generation levels, fuel costs
- Avista's variable power supply costs

\*Stochastic input  
Avista Corp.

# Aurora Pricing Methodology

- Each area contains a load and resources.
- Aurora dispatches resources to meet the load for each hour.
- Resource dispatch is dependent on fuel availability (wind, solar, hydro) and economic dispatch of the resource (fuel price).
- The model includes resource outages for maintenance and forced outage.
- For each location and hour, the model estimate a wholesale electric price using the marginal resource to serve the load.

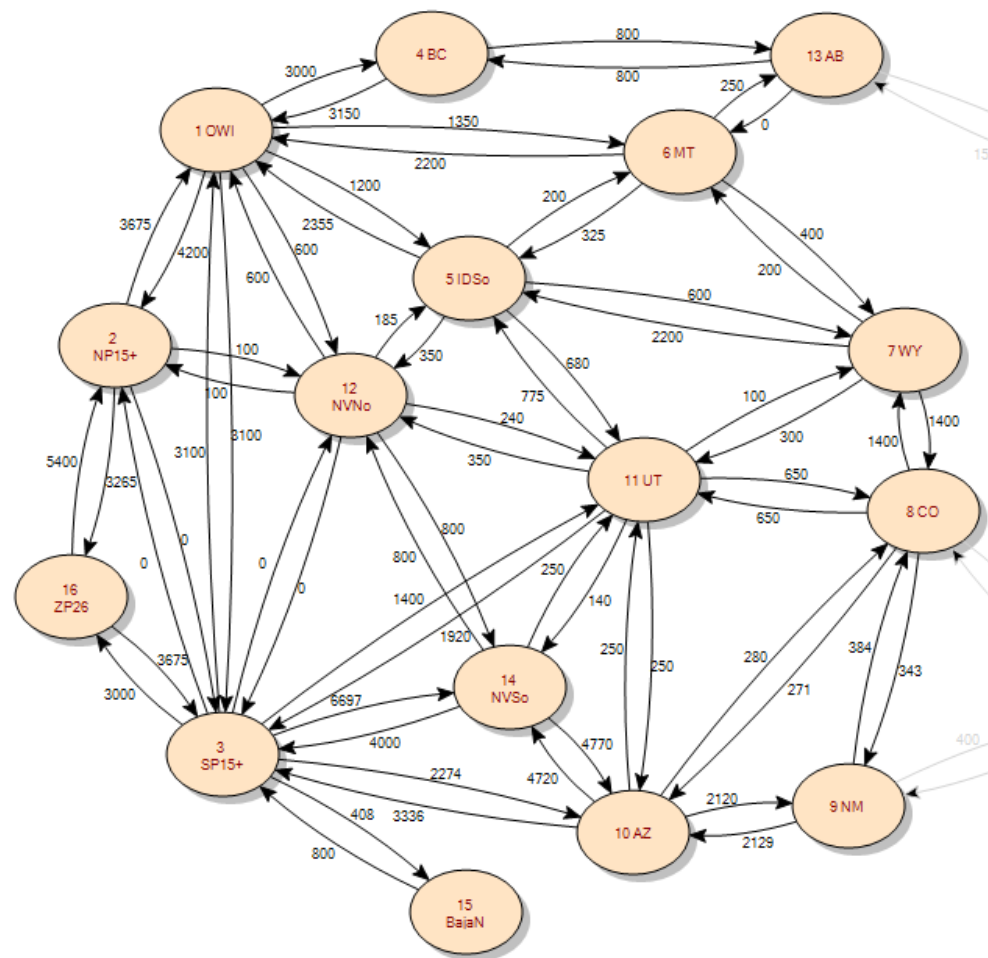

# Stochastic vs. Deterministic Analysis

- Deterministic analysis forecasts for a specific set of inputs.
  - Easier to understand
  - Works great for sensitivity analysis of specific changes
- Stochastic analysis forecasts for a range of inputs.
  - Range (or distribution) of results
  - Works great to understand risks of the inputs with variation
- Avista uses mean value of stochastic analysis for its Expected Case scenario.

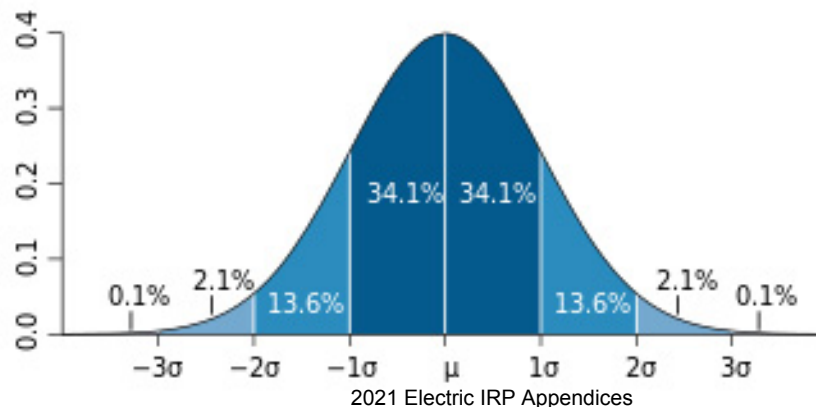



# Aurora Model Assumptions

- Forecast will start with the 2020 IRP
  - Uses latest available database from Energy Exemplar
- Proposed database changes
  - Natural gas prices (TAC 2)
  - Include new resource additions and announced retirements
  - Include known state/province environmental laws; including adjustments for oversupply events
  - Review inputs for load and new resources options
    - EV/rooftop solar forecast
    - New resources cost
  - Add proprietary Avista system information
  - Add stochastic distribution of regional hydro, natural gas, wind, and loads
- Avista will discuss non-confidential modeling changes in TAC 3
- All other Aurora assumptions are default values

# Aurora Run Process

- Once inputs are finalized (July 2020)
- Run Long Term “LT” study to estimate new resource additions for the full hourly study
- Test reliability under 500 simulations of varying hydro, load, forced outage, and wind conditions for future year (i.e. 2035)
- Update LT study to reflect any “need” for new resources and validate regional reliability
- Run deterministic study
- Run stochastic study (500 simulations, each hour for 2022-45)
- Run scenarios

# What Aurora Outputs are used?

- Resource dispatch for Avista existing resources and resource options
  - Estimate profitability of each supply and demand side resource
  - Estimate dispatch for REC calculation for CETA
- Value the cost to serve Avista's load
- Estimate the emissions associated with supply side and storage resources
- Estimate regional emission rates for savings for energy efficiency resources
- Gain understanding of the region market
- Data is used to populate PRiSM Model

# PRiSM- Preferred Resource Strategy Model

- Internally developed using Excel based linear/mixed integer program model (What's Best & Gurobi)
- Selects new resources to meet Avista's capacity, energy, and renewable energy requirements
- Outputs:
  - Power supply costs (variable and fixed)
  - Power supply costs variation
  - New resource selection (generation/conservation)
  - Emissions
  - Capital requirements



2021 Electric IRP Appendices



# What's new with PRiSM for this IRP

- New resources may be added to either WA, ID, or combined customer requirements.
- Existing resources will be allocated to each state using the PT ratio (~65% WA and ~35% ID).
- States may sell RECs between states.
- Washington's former share of Colstrip units will be assigned to new "shareholder" portfolio after 2025.

# Social Cost of Carbon (SCC)

- Social cost of carbon will be applied for new resource options for Washington customers; including
  - “Resulting” dispatch of natural gas resources from Aurora forecast of future real-time operations.
  - upstream emissions associated with natural gas drilling and transportation used to run facility.
  - manufacturing, construction, and operation of all resources (using NREL study).
  - storage and market resources will include estimate based on the average emissions rate of the region.
  - energy efficiency resources will use the hourly marginal emission rate of the region and reduction.
  - SCC will not be used for biomass/geothermal resources
- SSC prices will not be included for Idaho customers; although Avista could study this as a scenario

# Social Cost of Carbon Prices

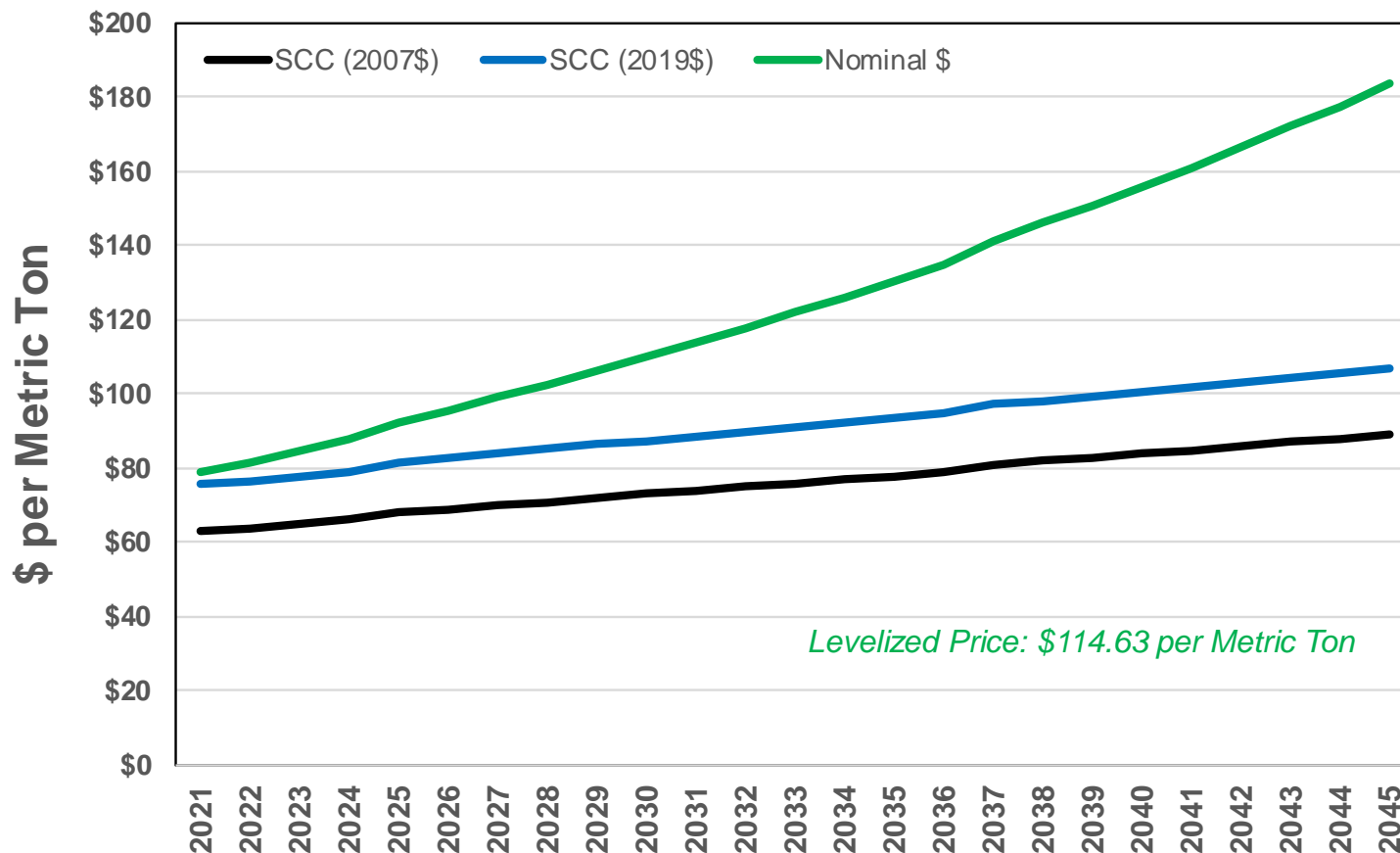

*Levelized Price: \$114.63 per Metric Ton*

- Social cost of carbon dioxide in 2007 dollars using the 2.5% discount rate, listed in table 2, [technical support document](#): Technical update of the social cost of carbon for regulatory impact analysis under Executive Order No. 12866, published by the interagency working group on social cost of greenhouse gases of the United States government, August 2016.
- Adjust to 2019\$ using Bureau of Economics GDP
- Adjust to Nominal \$ using 2.11% annual inflation rate

# Issues not finalized

- Prices of REC transfer between states
  - Avista acquires new qualifying resources to meet Washington's portion of the law, although it may transfer RECs between Idaho and Washington for the 20% portion of CETA
- How to count REC's toward meet the "80%" portion of CETA
  - Must bundled RECs only qualify if meeting Avista WA state load each hour?
  - Serve any WA state load or any utility load?
  - Avista needs clarification from WUTC



# What is Reliability Planning

- Estimate the probability of failure to serve all load
  - Avista's reliability target is 95% of all simulations serve 100% of load and reserve requirements
- Model randomizes events
  - Hydro, weather (load, wind, resource capacity), forced outages
- Typically large sample size 1,000 simulations
- Can be used to validate if a portfolio is reliable
  - Estimate the required planning reserve margin (PRM)
  - May be used to estimate peak credits for new resources (ELCC)
- Gold standard: regional wide program with enforced requirements to each utility
  - Set required methodology, planning margin, and resource contribution based on regional model

# Reliability Modeling

- 2020 IRP included ELCC analysis for a new resource alternatives and Avista Preferred Resource Portfolio for the year 2030
- Avista sees areas to improve in reliability modeling
  - Quantity of future years
  - Create ELCC curve for new resources
  - Study all portfolio's reliability requirements
  - Improve model speed
    - Single year study takes 3 days
  - Create dynamic capability with PRiSM

# Options to Address Reliability Modeling

Option	Pros	Cons
Continue using existing model (ARAM- excel model with solver)	<ul style="list-style-type: none"> <li>• Results reliable for Avista system</li> <li>• Fully developed</li> <li>• Potential for modest speed improvements</li> <li>• Control intellectual property</li> </ul>	<ul style="list-style-type: none"> <li>• Slow</li> <li>• Limited to two processes</li> <li>• User data/knowledge intensive</li> </ul>
Build custom professional software	<ul style="list-style-type: none"> <li>• Likely faster speed</li> <li>• Reliable results</li> <li>• Potential to integrate with PRISM</li> </ul>	<ul style="list-style-type: none"> <li>• Time to implement</li> <li>• Cost</li> </ul>
Adapt Aurora	<ul style="list-style-type: none"> <li>• User knowledge</li> <li>• Cost</li> <li>• Flexibility</li> <li>• Data management</li> <li>• Parallel processing limit by machines</li> </ul>	<ul style="list-style-type: none"> <li>• Slow (cost to speed up-Gurobi)</li> <li>• Hydro logic- results in higher LOLP</li> <li>• May only work for LOLH</li> <li>• Storage logic is slow</li> </ul>
New Genesis Model (Power Council)	<ul style="list-style-type: none"> <li>• Regional standard</li> <li>• Addresses regional market availability issues</li> <li>• Strong hydro logic</li> <li>• New technology</li> </ul>	<ul style="list-style-type: none"> <li>• Regional focus</li> <li>• Model in progress; not available for this IRP</li> </ul>
Purchase Software/Hire Consultant	<ul style="list-style-type: none"> <li>• Flexibility</li> <li>• Data management</li> <li>• Reliable results ?</li> </ul>	<ul style="list-style-type: none"> <li>• Cost</li> <li>• Implementation time</li> <li>• Risk</li> </ul>
Regional Resource Adequacy Market	<ul style="list-style-type: none"> <li>• Clear requirements for load and resources on a regional basis</li> <li>• Best case scenario</li> </ul>	<ul style="list-style-type: none"> <li>• Market in development not ready for this IRP</li> <li>• May have to make estimates for future years</li> </ul>

# Reliability Next Steps

- Continue testing Aurora application with Gurobi to understand speed improvements and result improvements
- If we use ARAM
  - Remain with single year study (2030 or 2035)
  - Use 2020 IRP ELCC estimates
  - Estimate ELCC curves for key resources (wind/ storage)
  - Conduct study for each portfolio- may result in different planning margins
  - Move to using RA logic for next IRP if a regional program is developed
- Aurora option may expand options to additional forecast years and ELCC studies
- Update progress with TAC once solution is finalized

# Data Availability Proposal

- **Aurora**
  - Model requires licensing agreement with Energy Exemplar
  - Avista specific data is confidential
  - Model results will be retained by Avista
  - Avista will provide summary level results for all studies (i.e. regional prices, regional emissions, regional dispatch)
- **PRISM**
  - All files will be available, includes annual data for each of 500 simulations for Avista resources and load
  - Requires What's Best and Gurobi license to solve, but results are fully visible
- **Load Forecast**
  - Models are confidential; models includes specific customer information and confidential data
  - Monthly energy and peak data will be available by state, along with break down between new +/- loads (i.e. rooftop solar, electric vehicles, and natural gas)
  - Full discussion of process will be covered in TAC 2
- **Resource Costs**
  - Supply-side resources spreadsheet will be available with all calculations
  - Demand-side resources; measure list and costs will be public for energy efficiency and demand response.
- **Transmission & Distribution**
  - All models and data are confidential
  - Avista will provide cost and requirements for resource integration as provided in prior IRPs
  - Full discussion of process will be covered in TAC 3
- **Reliability Planning**
  - Availability will depend on modeling solution
  - Results will be retained and available



# 2021 Electric IRP Generation Resource Options

Lori Hermanson, Senior Power Supply Analyst  
First Technical Advisory Committee Meeting  
June 18, 2020

# Overview & Considerations

- The assumptions discussed are “today’s” estimates – likely to be periodically revised
- IRP supply-side resources are commercially available technologies with potential for development within or near Avista service territory
- Resource costs vary depending on location, equipment, fuel prices and ownership; while IRPs use point estimates, actual costs will be different.
- Certain resources will be modeled as purchase power agreements (PPA) while others will be modeled as Avista “owned”. These assumptions do not mean they are the only means of resource acquisition.
- No transmission or interconnection costs are included at this time.
- Natural gas prices are 2020 IRP prices and will be revised with the “final” assumptions
- An Excel file will be distributed with all resources, assumptions and cost calculations for TAC members to review and provide feedback.

## Outlook Since Last IRP

- Natural gas small CT – 4.4% ↑
- Natural gas CCCT - 5.8% ↑
- Solar – 8% ↓
- Wind – 0.3% ↓
- Lithium Ion Storage – 8% ↑

*Gas turbines 2022 vs 2020; others are 2022 vs 2022*



# Proposed Natural Gas Resource Options

## Peakers

- Simple Cycle Combustion Turbine (CT)
  - Aero and frame units
  - Smaller units 44 MW to 84 MW
- Hybrid CT
  - 92 MW
- Reciprocating Engines
  - 9 MW to 18 MW units with up to 10 engines

## Baseload

- Both modern and advanced Combined Cycle CT (CCCT) will be evaluated
  - Smaller option 249 MW (3x2)
  - Larger options 311 MW to 587 MW (1x1)
- Large 2x1 technology not modeled

Natural gas turbines are modeled using a 30-year life with Avista ownership

# Renewable Resource Options

## All Purchase Power Agreement (PPA) Options

### Wind

- On-system wind (100 MW)
- Off-system wind (100 MW)
- Montana wind (100 MW)
- Offshore wind (100 MW)
  - Share of a larger project

### Solar

- Fixed PV Array (5 MW AC)
- On-System Single Axis Tracking Array (100 MW AC)
- Off-system Single Axis Tracking Array (100 MW AC) located in southern PNW
- On-System Single Axis Tracking Array (100 MW AC) with 25 MW 4 hour lithium-ion storage resource
- May model alternative solar with smaller battery configurations

# Other “Clean” Resource Options

- Geothermal (25 MW)
  - Off-system PPA
- Biomass (25 MW)
  - i.e. Kettle Falls 3 or other
- Nuclear (100 MW)
  - Off-system PPA share of a mid-size facility
- Renewable Hydrogen
  - Fuel Cell (25 MW)
  - Natural Gas Turbine Retrofit

# Storage Technologies

## Lithium-Ion

- Assumes: 88% round trip efficiency (RTE), 10-year operating life
- Assumes Avista ownership
- 5 MW Distribution Level
  - 6 hours (30 MWh)
- 25 MW Transmission Level
  - 4 hours (100 MWh)
  - 8 hours (200 MWh)
  - 16 hours (400 MWh)

## Other Storage Options

- Assumes 20 to 30-year life and Avista ownership
- 25 MW Vanadium Flow (70% RTE)
  - 4 hours (100 MWh)
- 25 MW Zinc Bromide Flow (67% RTE)
  - 4 hours (100 MWh)
- 25 MW Liquid Air (60-70% RTE)
- 100 MW Pumped Hydro
  - Share of larger project
  - PPA assumption

*Updates to storage costs are likely as additional information becomes available*

Avista Corp.

# Resource Upgrades

- **Rathdrum CT** [*natural gas peaker*]
  - 5 MW by 2055 uprates
  - 24 MW add supplemental compression
  - 17 MW (summer), 0 MW (winter) Inlet Evaporation
- **Kettle Falls** [*biomass*]
  - 12 MW by repowering with larger turbine during replacement
- **Long Lake 2<sup>nd</sup> Powerhouse** [*hydroelectric*]
  - 68 MW, 12 aMW with additional powerhouse located at the current “cutoff” dam
- **Cabinet Gorge** [*hydroelectric*]
  - 110 MW, 18 aMW using the “bypass” tunnels to capture runoff spill

# Natural Gas Fixed & Variable Costs

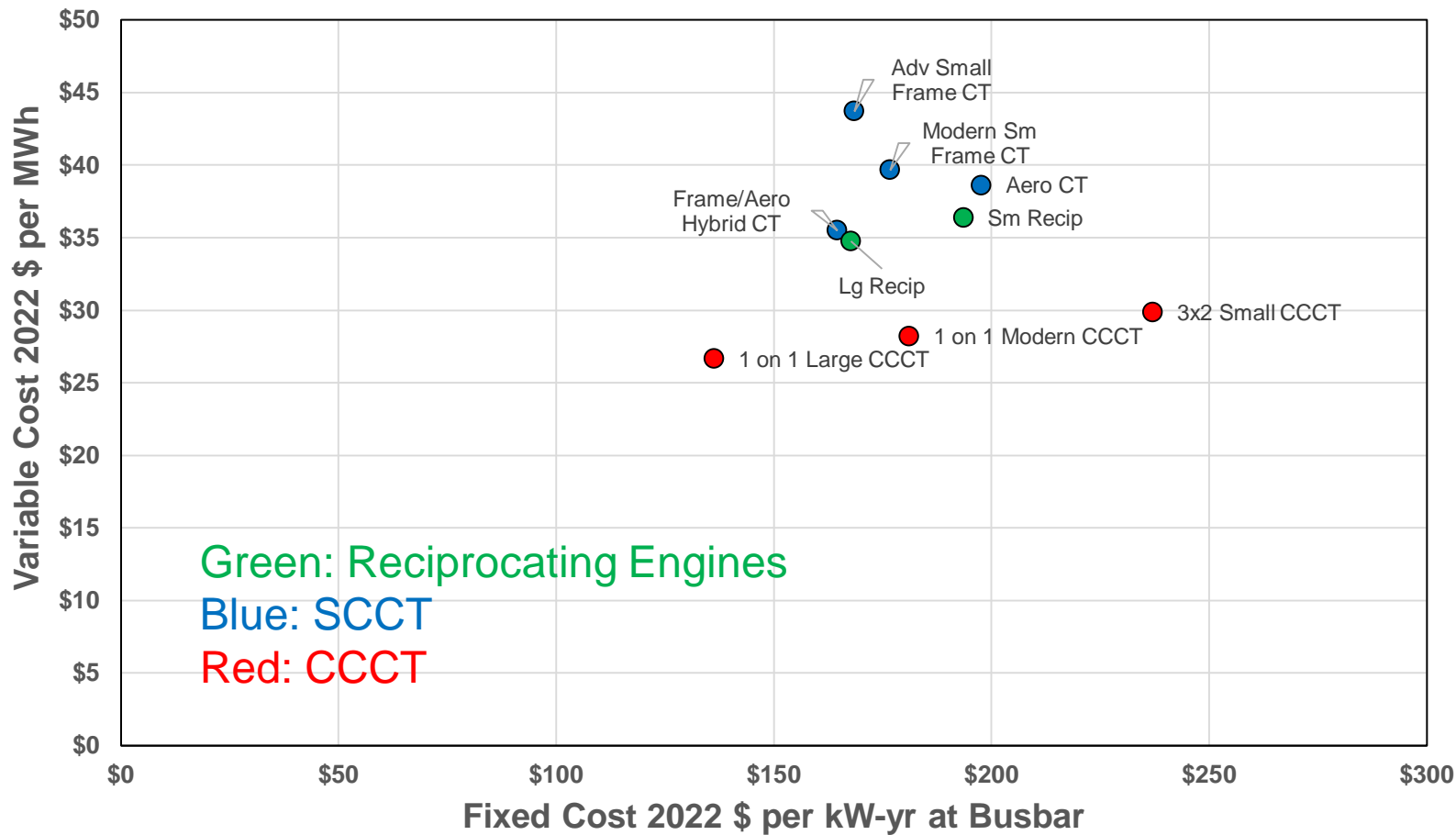

# PPA Resource Cost Analysis

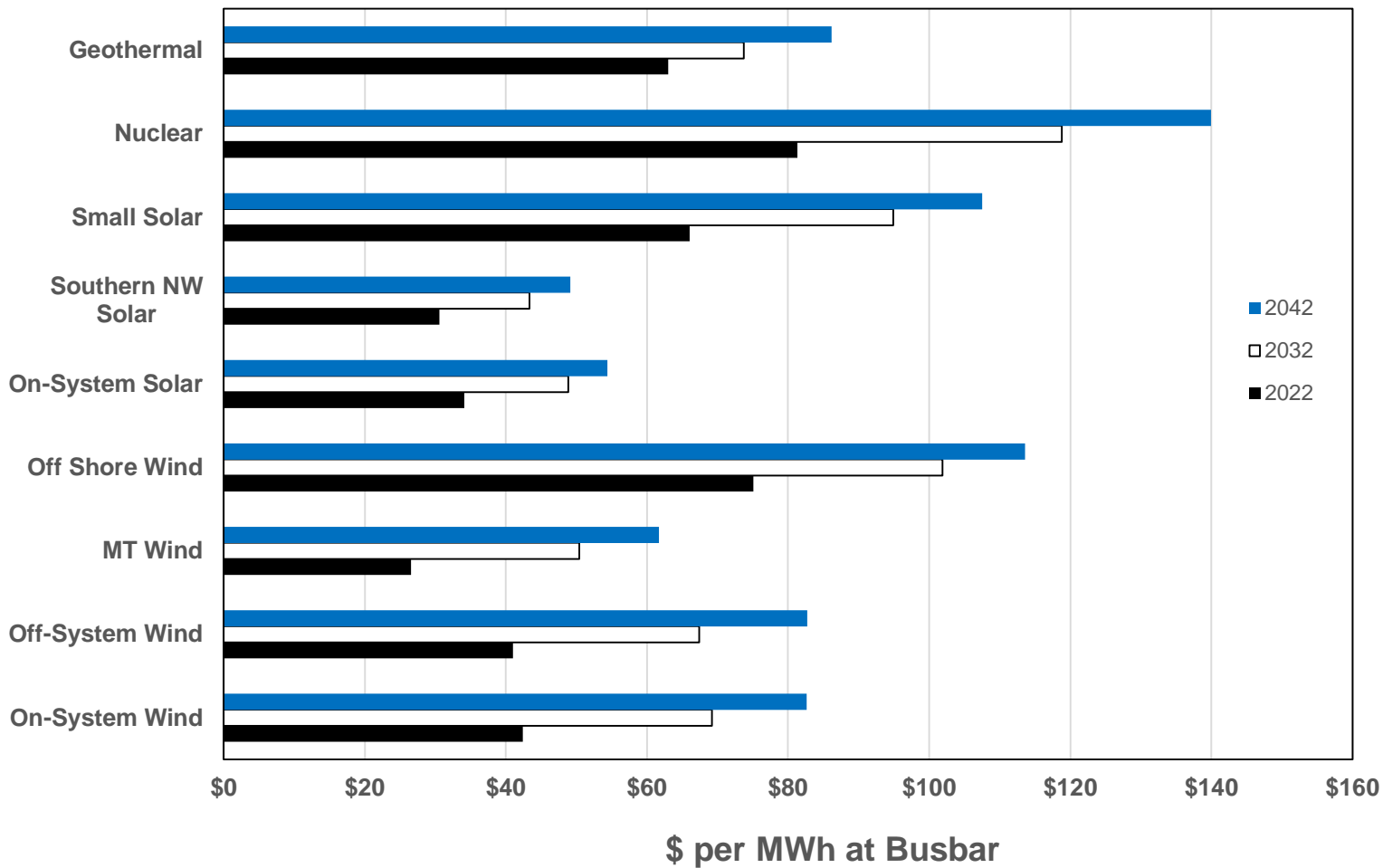

# Storage Costs

## Capacity based cost analysis

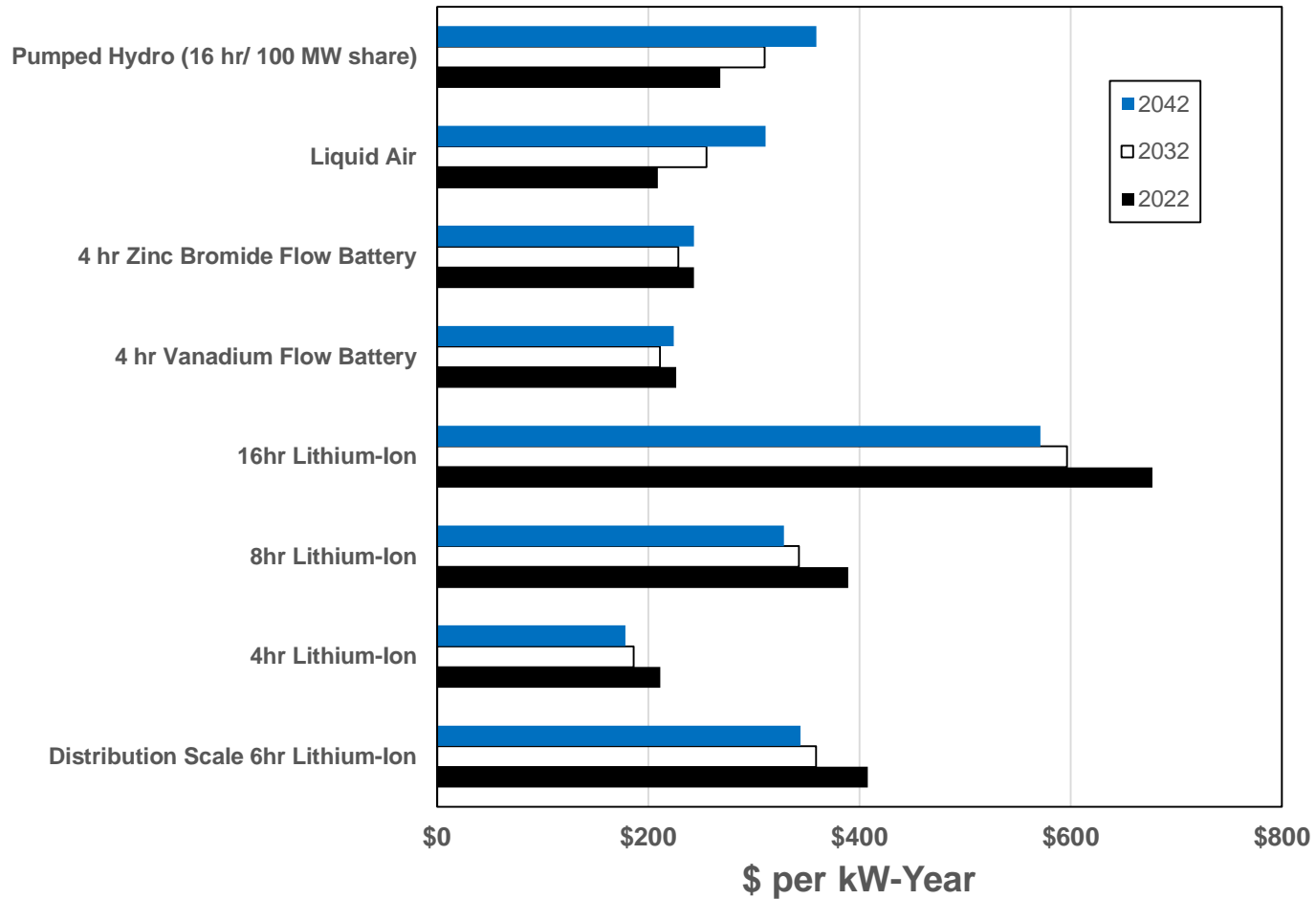



# Storage Costs

## Energy based cost analysis

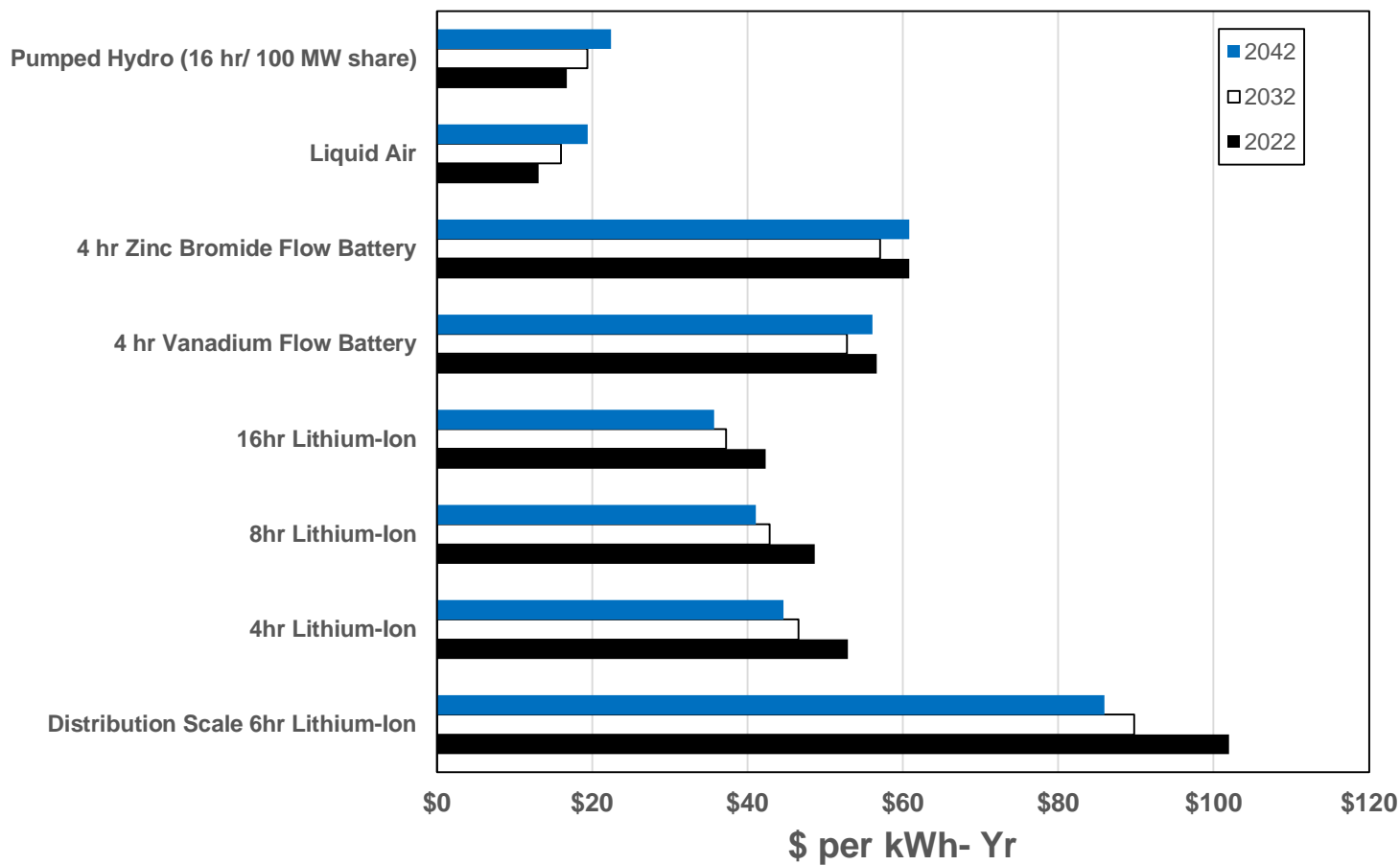

# Facility Upgrade Cost Analysis

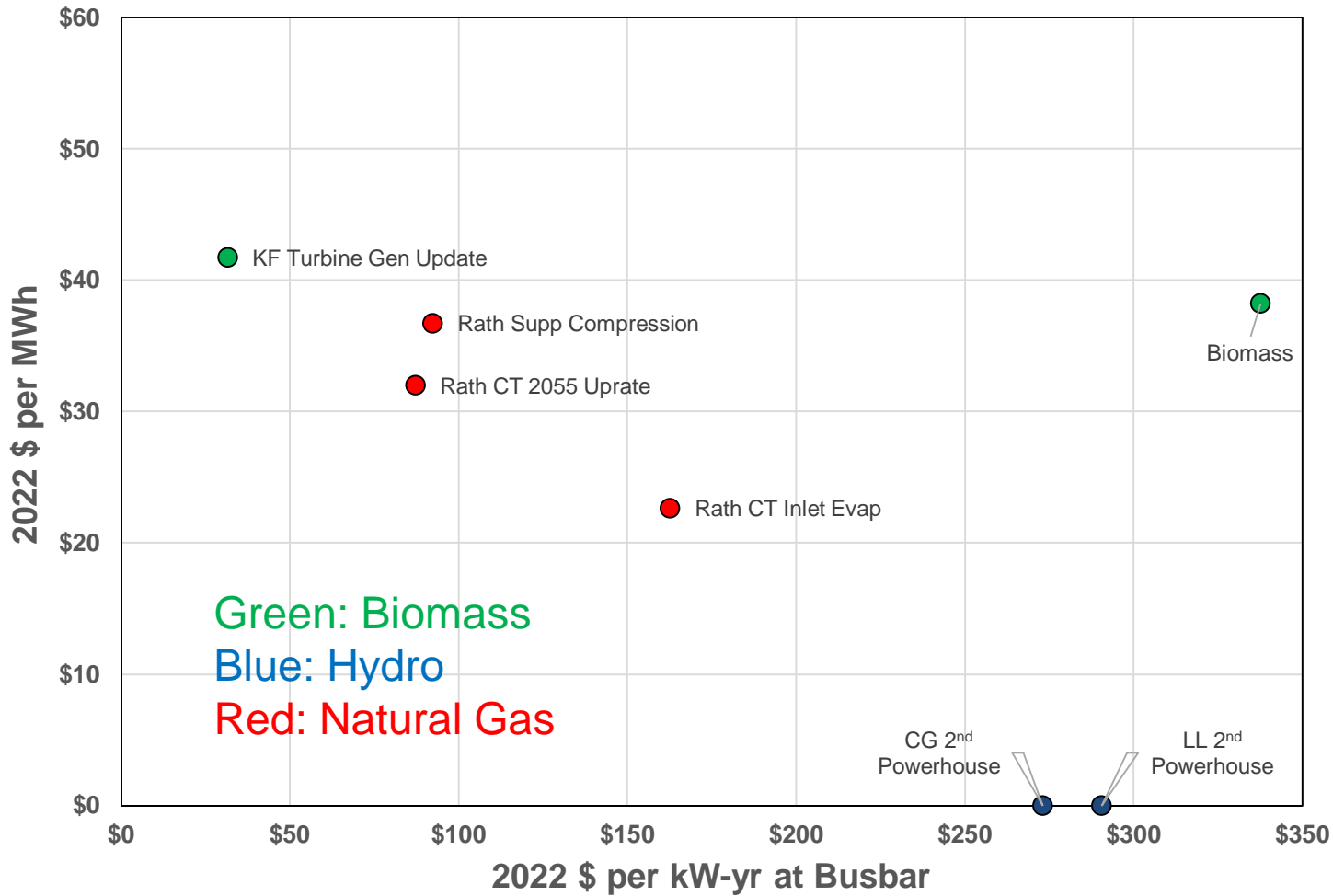

# Other Power Purchase Options

- Market Power Purchases
  - Firm purchases
  - Real-time
- Mid-Columbia Hydro
  - Renegotiate slice contracts from Mid-C PUDs
- Acquire existing resources from IPPs
- Renegotiate Lancaster PPA
- BPA
  - Block surplus contract: up to 7-year term at BPA “cost”
  - NR Energy Sales: \$78.94 MWh
  - After 2028, other potential options when current Regional Dialogue contracts expire





# Review Excel Sheet



# 2021 Electric IRP Washington Vulnerable Populations & Highly Impacted Communities

James Gall, IRP Manager  
First Technical Advisory Committee Meeting  
June 18, 2020

# CETA: Section 1

(6) The legislature recognizes and finds that the public interest includes, but is not limited to:

- The equitable distribution of energy benefits and reduction of burdens to **vulnerable populations** and **highly impacted communities**;
- long-term and short-term public health, economic, and environmental benefits and the reduction of costs and risks;
- and energy security and resiliency.

It is the intent of the legislature that in achieving this policy for Washington, there should not be an increase in environmental health impacts to **highly impacted communities**.

# Definitions

(23) "**Highly impacted community**" means a community designated by the department of health based on cumulative impact analyses in section 24 of this act or a community located in census tracts that are fully or partially on "Indian country" as defined in 18 U.S.C. Sec. 1151

(40) "**Vulnerable populations**" means communities that experience a **disproportionate** cumulative risk from environmental burdens due to:

- (a) Adverse socioeconomic factors, including unemployment, high housing and transportation costs relative to income, access to food and health care, and linguistic isolation; and
- (b) Sensitivity factors, such as low birth weight and higher rates of hospitalization.



# How Avista Reaches These Communities Today

- Low income assistance
- Senior/disability rate discount
- Project share
- Energy efficiency programs
- Energy fairs and workshops
- Corporate and Avista Foundation giving
- Energy home audits
- Prevention of wood smoke part of energy efficiency analysis
- Wildfire mitigation program
- Public access to hydro facilities
- Park development
- Neighborhood engagement when developing projects
- Tribal hiring
- Energy pathways program
- Tribal settlements
- Hydro relicensing outreach
- Wildlife land purchases



# IRP Requirements (Section 14)

(k) An assessment, informed by the cumulative impact analysis conducted under section 24 of this act, of: Energy and nonenergy benefits and reductions of burdens to vulnerable populations and highly impacted communities; long-term and short-term public health and environmental benefits, costs, and risks; and energy security and risk;

**Sec. 24.** By December 31, 2020, the department of health must develop a cumulative impact analysis to designate the communities highly impacted by fossil fuel pollution and climate change in Washington. The cumulative impact analysis may integrate with and build upon other concurrent cross-agency efforts in developing a cumulative impact analysis and population tracking resources used by the department of health and analysis performed by the University of Washington department of environmental and occupational health sciences. [<https://www.doh.wa.gov/CETA/CIA>]

# How Will Avista Address These New Requirements?

- Gain perspectives from advisory group(s) for additional requirements or from new rules
- Identify and engage highly impacted communities & vulnerable populations
  - Advisory groups
  - Encourage representatives to either participate in existing advisory groups or potentially create a new advisory group to address the community impacts.
- Create baseline data
- Estimate benefits/impacts from IRP

# Identifying Communities or “Customers”

## Highly Impacted Communities

- Cumulative Impact Analysis
- Tribal lands
  - Spokane
  - Colville
- Locations should be available by end of 2020
  - State held workshops in August & September 2019

## Vulnerable Populations

- Use Washington State Health Disparities map
  - What is disproportionate on a scale of 1 to 10?
  - Avista proposes areas with a score 8 or higher in either Socioeconomic factors or Sensitive population metrics
- Should we include other metrics to identify these communities?

# Environmental Health Disparities Map

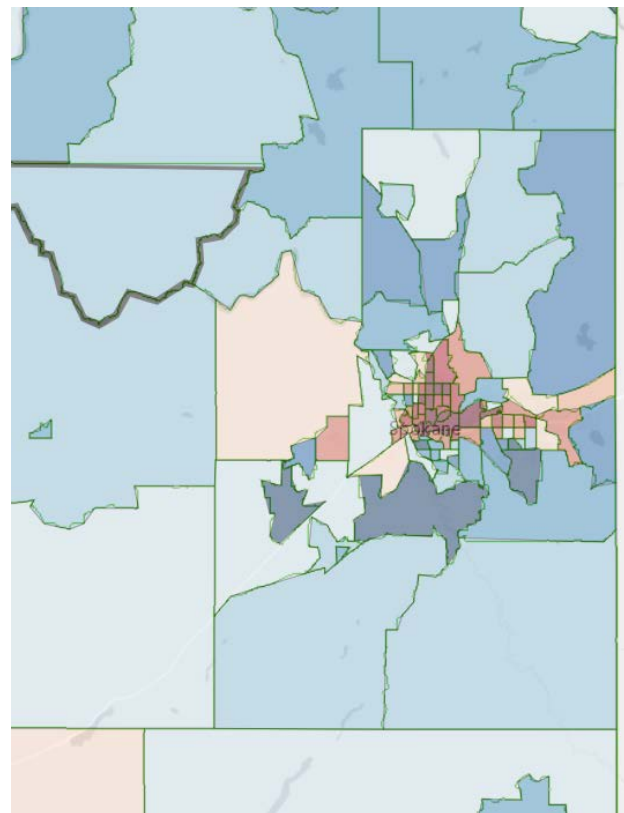
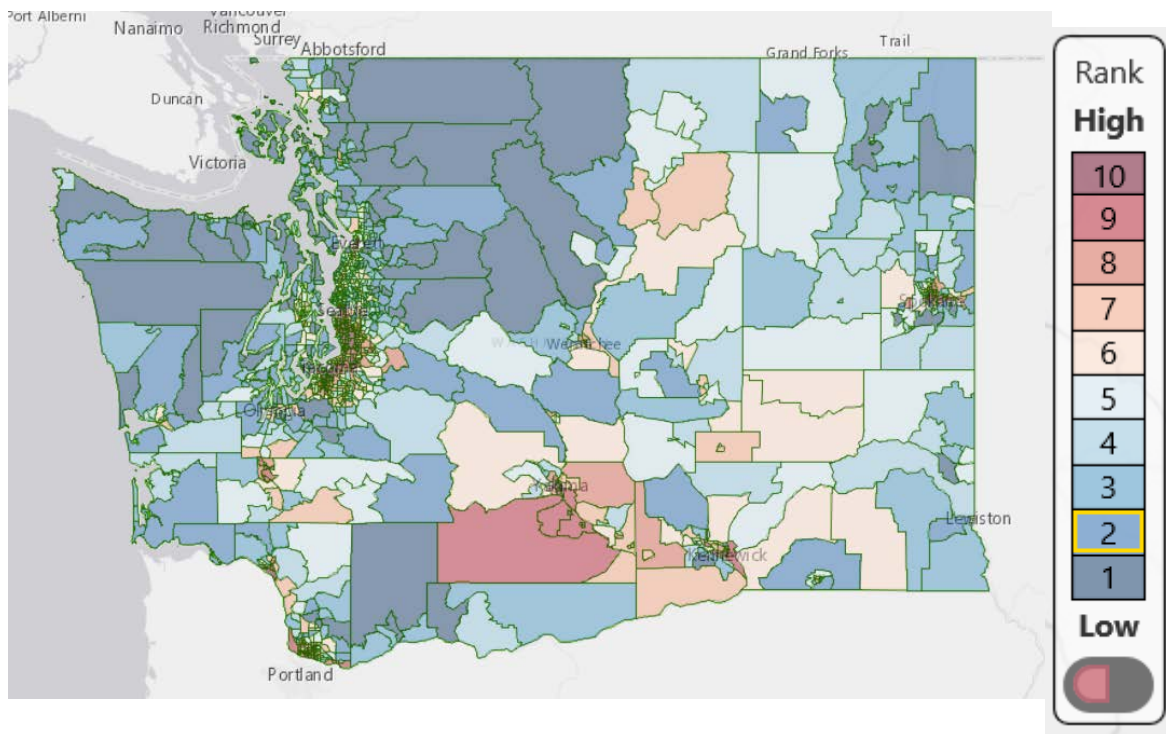

<https://fortress.wa.gov/doh/wtn/wtnibl/>

## Data by FIPS Code

Avista Corp.

2021 Electric IRP Appendices



# Environmental Health Scoring

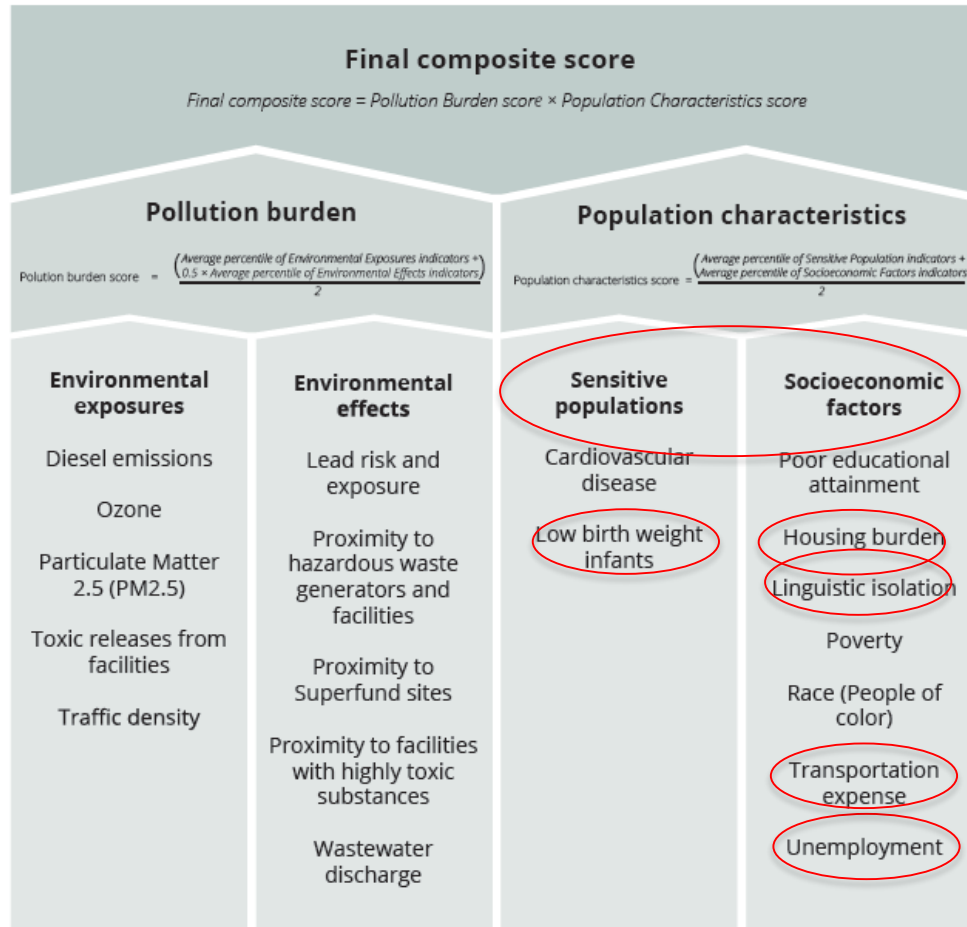

Circle areas match definition of vulnerable population, although access to food & health care, higher rates of hospitalization are not expressively included but are an indication of poverty

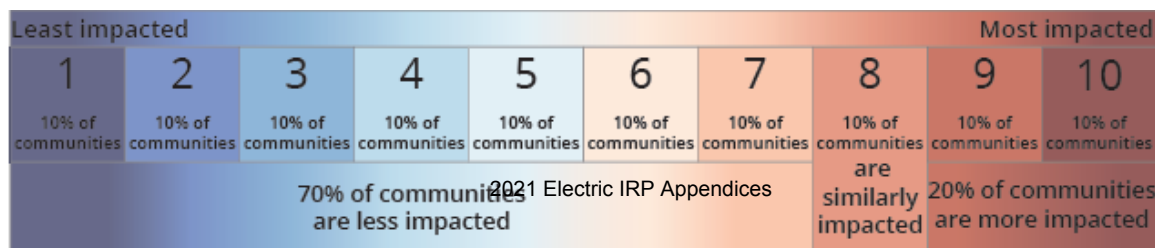

# Eastern Washington Communities

## Socioeconomic Factors

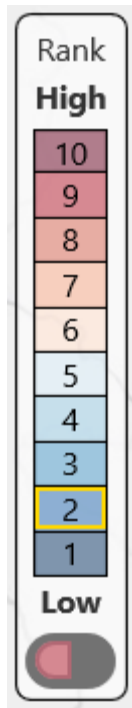
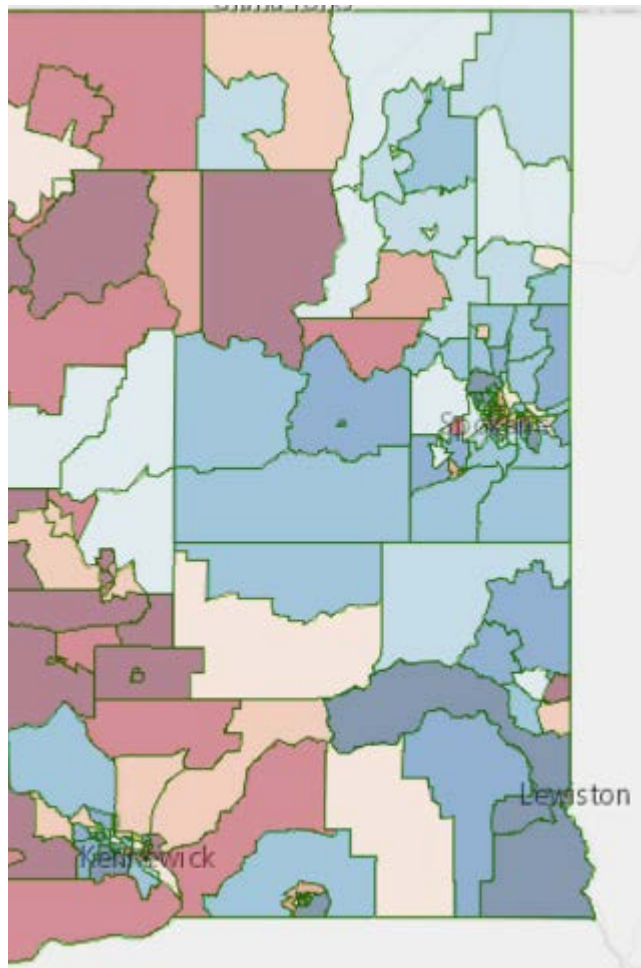

## Sensitive Populations

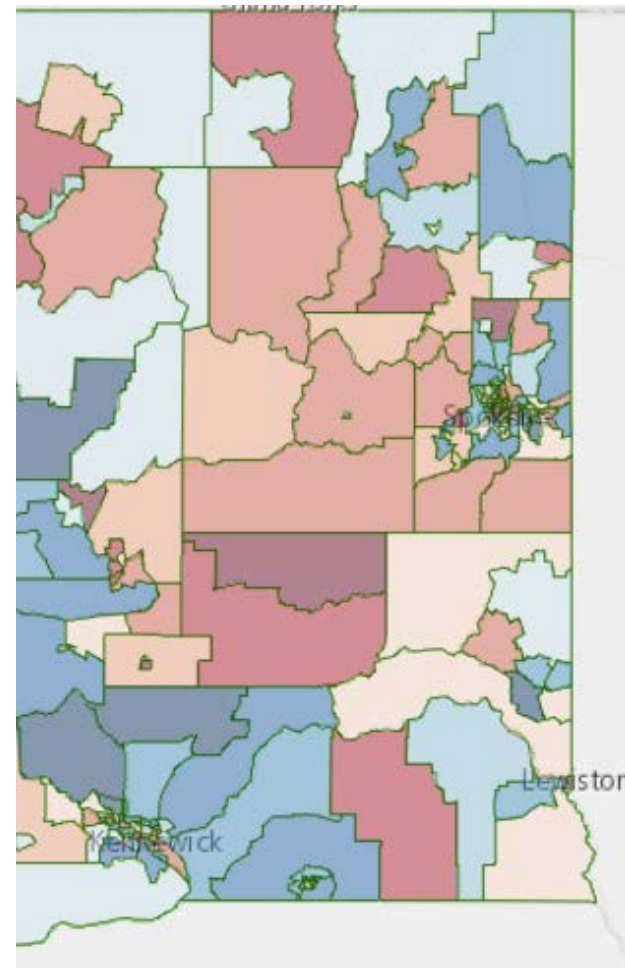

# Avista Electric Service Territory

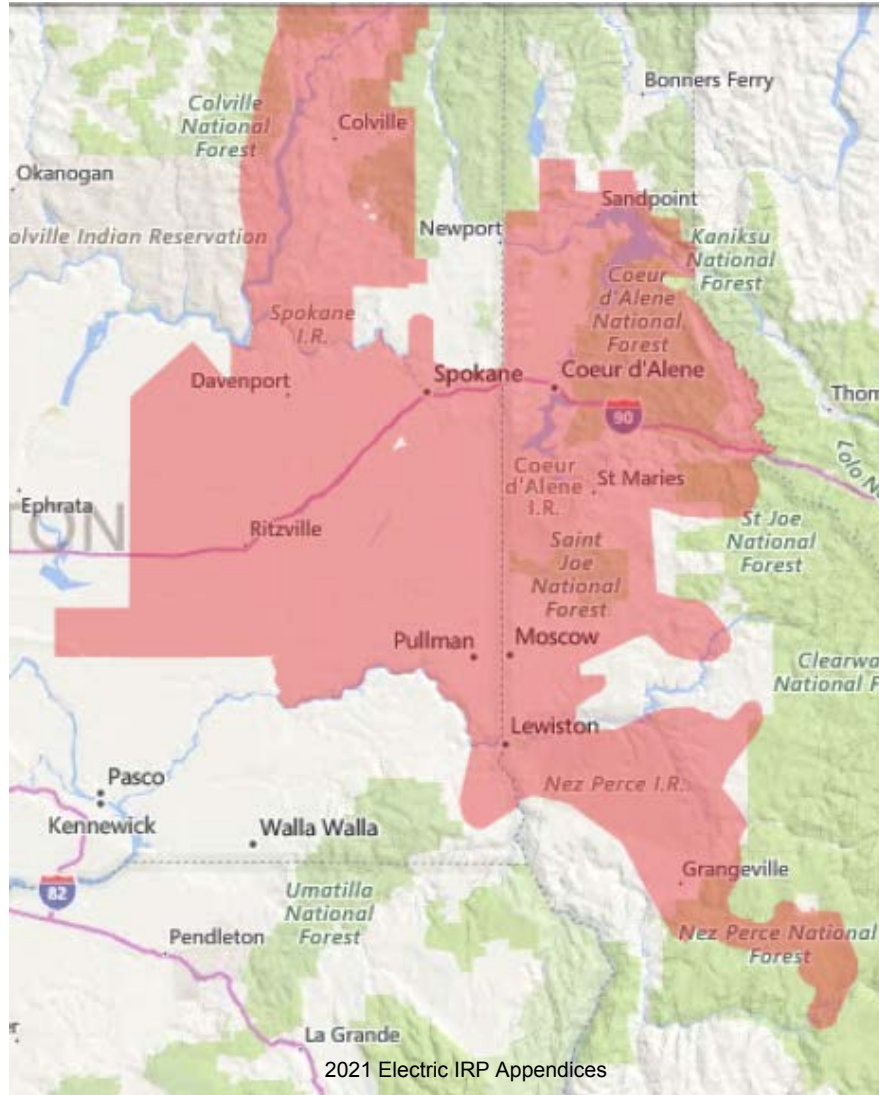



# Data Analysis of Vulnerable Populations

Avista has 145 communities identified

- 35 (24%) have an 8 or higher for Socioeconomic Factors
- 55 (38%) have an 8 or higher for Sensitive Populations
- 67 (46%) are considered vulnerable

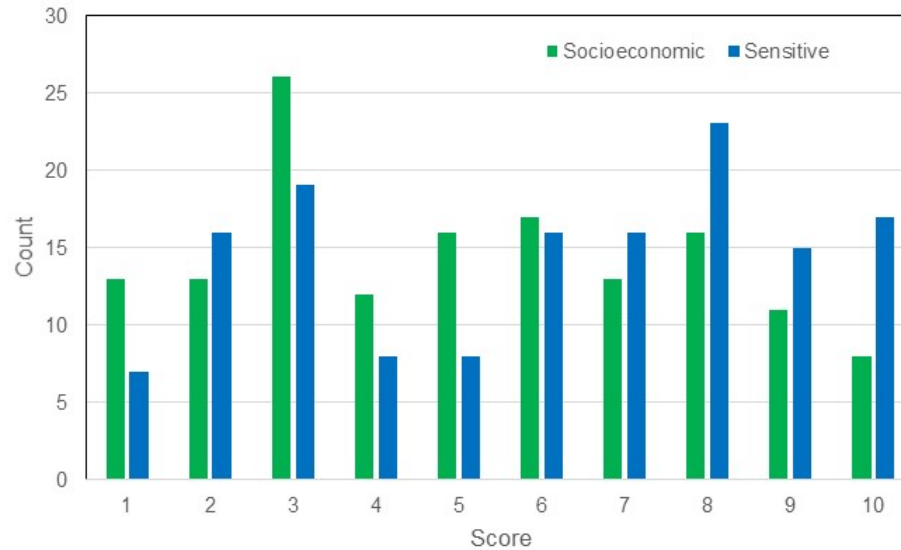

	Socioeconomic	Sensitive
Avista (Mean)	5.1 (5 median)	6.0 (6 median)
State (Mean)	5.4 (5 median)	5.2 (5 median)
Avista (Stdev)	2.67	2.83
State (Stdev)	2.88	2.88

# Selected Vulnerable Populations

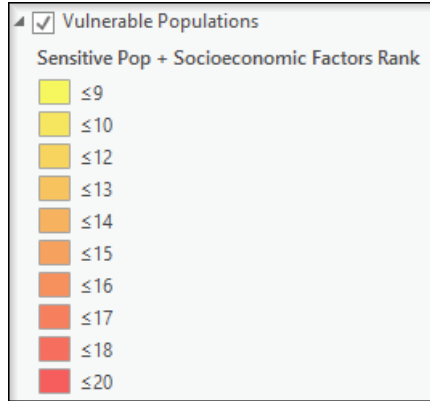

Data is shown by combined score

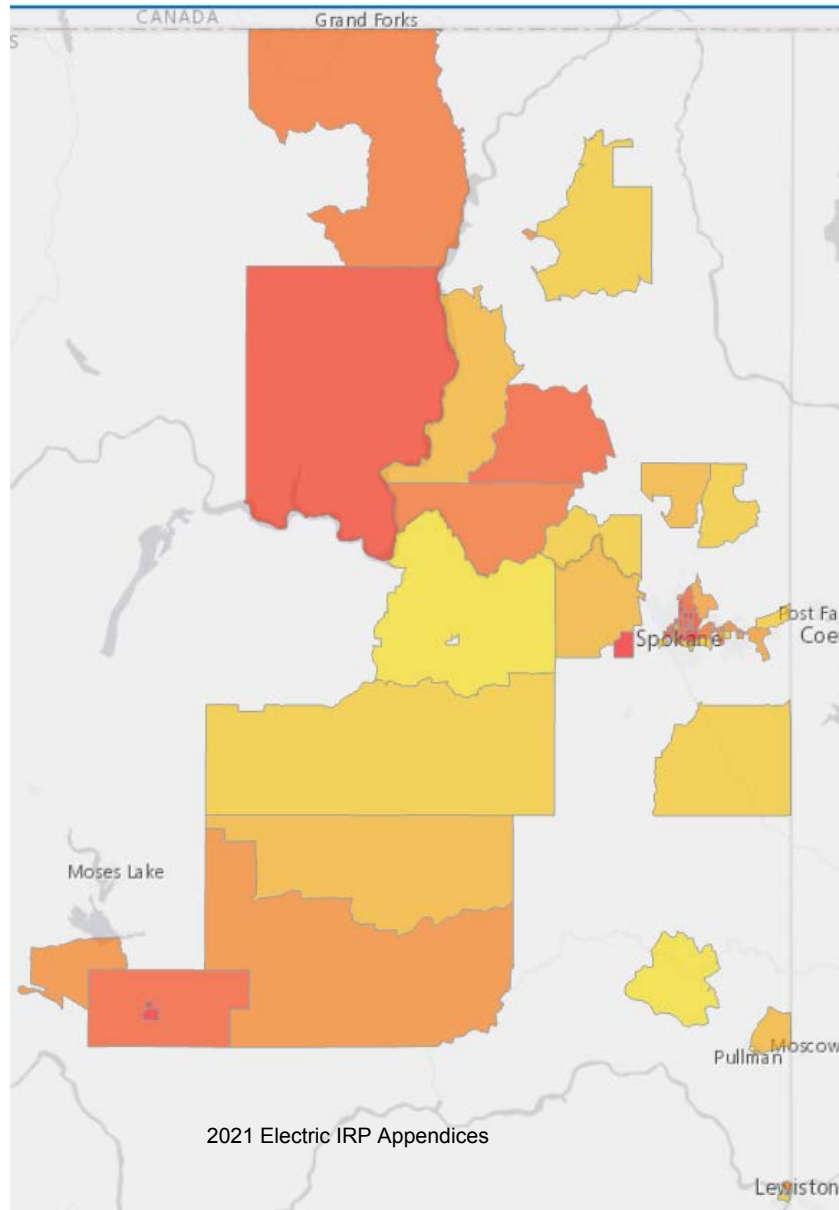

# Spokane Area “Avista” Vulnerable Populations

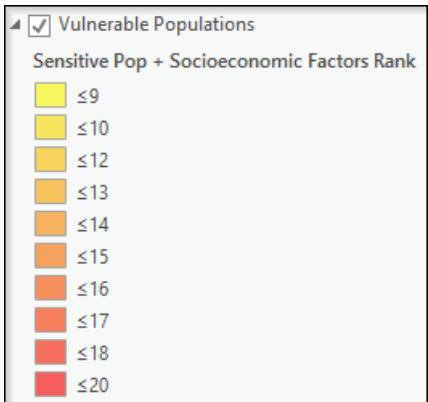

Data is shown by combined score

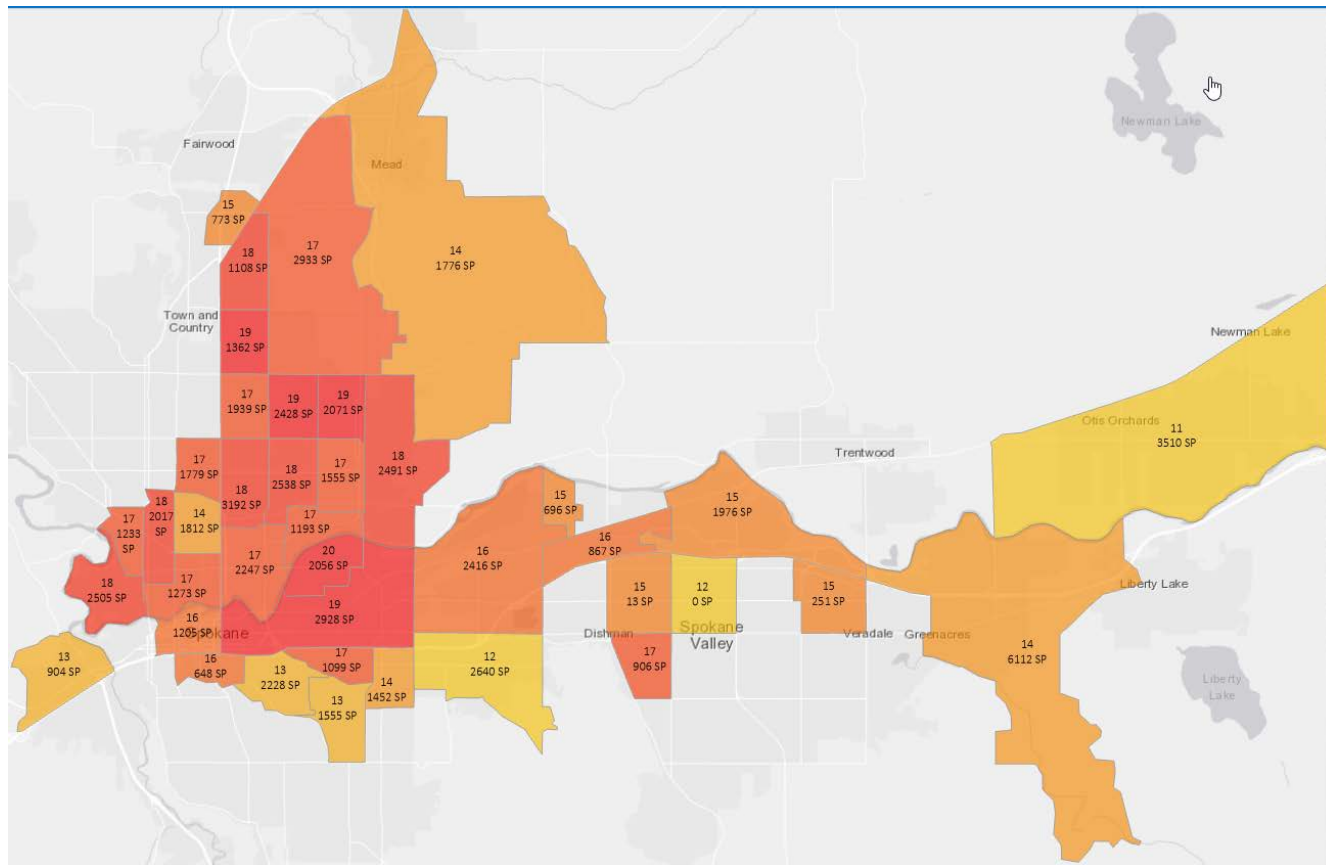

# IRP Metrics

Metric	IRP Relationship
Energy Usage per Customer	<ul style="list-style-type: none"> <li>• Expected change taking into account selected energy efficiency then compare to remaining population.</li> <li>• EE includes low income programs and TRC based analysis which includes non-economic benefits.</li> </ul>
Cost per Customer	<ul style="list-style-type: none"> <li>• Estimate cost per customer then compare to remaining population.</li> <li>• How do IRP results compare to above 6% of income?</li> </ul>
Preference	<ul style="list-style-type: none"> <li>• Should the IRP have a monetary preference?               <ul style="list-style-type: none"> <li>• For example- should all customers pay more to locate assets (or programs) in areas with vulnerable populations or highly impacted communities?</li> <li>• If so, how much more?</li> </ul> </li> </ul>

# IRP Metrics

Metric	IRP Relationship
<p>Reliability</p> <ul style="list-style-type: none"> <li>• SAIFI: System Average Interruption Frequency Index</li> <li>• MAIFI: Momentary Average Interruption Frequency Index</li> </ul>	<ul style="list-style-type: none"> <li>• Calculate baseline for each distribution feeder and match with communities</li> <li>• Estimate benefits for area with potential IRP distribution projects</li> </ul>
<p>Resiliency:</p> <ul style="list-style-type: none"> <li>• SAIDI: System Average Interruption Duration Index</li> <li>• CAIDI: Customer Average Interruption Duration Index</li> <li>• CELID: Customer's Experiencing Long Duration Outages</li> </ul>	<ul style="list-style-type: none"> <li>• Compare to other communities as baseline</li> <li>• May be more appropriate in Distribution plan rather than IRP</li> </ul>
<p>Resource Analysis</p>	<ul style="list-style-type: none"> <li>• Estimate emissions (NO<sub>x</sub>, SO<sub>2</sub>, PM2.5, Hg) from power projects located in/near identified communities</li> <li>• Identify new resource or infrastructure project candidates with benefit to communities; i.e. economic benefit, reliability benefit</li> <li>• Identify how resource can benefit energy security</li> </ul>

# TAC Input

- What other metrics can we provide in an IRP to show vulnerable populations and highly impacted communities are not harmed by the transition to clean energy

### **Attendees: TAC 1, Thursday, June 18, 2020 Virtual Meeting on Skype:**

Shawn Bonfield (Avista), Terrance Browne (Avista), Logan Callan (City of Spokane), Teri Carlock (IPUC), John Chatburn (Idaho Governor's Office of Energy and Mineral Resources), Corey Dahl (Washington State Office of the Attorney General), Thomas Dempsey (Avista), Chris Drake (Avista), Annabel Drayton (NW Energy Coalition), Michael Eldred (IPUC), Nancy Esteb (Renewable Energy Coalition), Chip Estes, Rachelle Farnsworth (IPUC), Ryan Finesilver (Avista), Damon Fisher (Avista), Grant Forsyth (Avista), James Gall (Avista), Annie Gannon (Avista), Amanda Ghering (Avista), Dainee Gibson (Idaho Conservation League), Kate Griffith (Washington UTC), Vlad Gutman-Britten (Climate Solutions), Leona Haley (Avista), Jared Hansen (Idaho Power), Lori Hermanson (Avista), Kevin Holland (Avista), Kristine Holmberg (Avista), Tina Jayaweera (Northwest Power and Conservation Council), Clint Kalich (Avista), Kevin Keyt (IPUC), Kathleen Kinney (Biomethane, LLC), Scott Kinney (Avista), Dean Kinzer (Whitman Co. Commissioner's Office), Erik Lee (Avista), John Lyons (Avista), James McDougal (Avista), Matt Nykiel (Idaho Conservation League), Tom Pardee (Avista), Jørgen Rasmussen (Solar Acres Farm), John Ross, John Rothlin (Avista), Jennifer Snyder (Washington UTC), Dean Spratt (Avista), Jason Thackston (Avista), Marissa Warren (Idaho Governor's Office of Energy and Mineral Resources), Amy Wheeless (NW Energy Coalition), and 13 Guests who did not identify themselves.

Questions and comments are identified by speaker when possible and text in *italics* records the responses by the presenters.

### **TAC Expectations & Process Overview**

**John Lyons:** A new stakeholder feedback form will be added to the IRP website. Slides from this meeting will be posted on the IRP website next week. The generation resource options spreadsheet was emailed earlier this week. Avista is also considering different options for meetings and sharing of TAC materials, but we will continue to post meeting notes on the website. We will attempt to record these meetings.

**John Lyons:** Washington now requires an IRP every 4 years with an update after two years. Washington law (Clean Energy Transformation Act or CETA) does not allow for the Commission to acknowledge an IRP without all of the CETA requirements and rulemaking in place, moving the next IRP out until 4/1/21. The 2021 IRP will be modeling 2021 through 2045 (for CETA). Avista welcomes requests for additional studies by August 1, 2010, but earlier is better for accommodating any requests. The dates of future TAC meetings are in the presentation and posted on the IRP web site.

## 2020 IRP Acknowledgement – John Lyons

IRP acknowledgement means the filing has met the rules for IRPs in both states. It includes comments about topics to include or build upon in the next IRP. Acknowledgement does not provide rate recovery, but is a component of rate recovery. If a new resource wasn't chosen in the IRP, we have more explanation required what it was not identified in the IRP. Because of the extension for the 2020 IRP, we do not have acknowledgements to review in this meeting. The Idaho Commission is accepting comments from the public through August 19, 2020 with replies due from the Company by September 2, 2020. A key area of expected concern is how Avista will develop an IRP that accommodates Washington's CETA requirements, but not adversely impact Idaho customers. Washington suspended acknowledgement letter through December 31, 2020, but provided some comments on the work plan including providing an opportunity for stakeholder input on the conservation potential assessment (CPA) before finalization, extending participation to a broader public audience, and providing a timeline of IRP data and when it will become available.

## CETA Rulemaking Update – Shawn Bonfield

CETA applies to all electric utilities in Washington. It requires 100% clean energy, the elimination of coal from serving Washington customers by 2025, greenhouse gas neutral by 2030 and at least 80% clean, and 100% renewable or generated from zero-carbon resources by 2045. CETA also requires equitable distribution of energy and non-energy benefits and to ensure public health and environmental benefits. Avista is well above the 15% renewable standard required under the Energy Independence Act (I-937). Avista is about 60% clean/renewable today. 2020 is a big year for CETA rulemaking: Phase 0 included the overall implementation plan. Phase 1 (August 2019 – January 1, 2021) includes the already published the Social Cost of Carbon (<https://www.utc.wa.gov/regulatedIndustries/utilities/Pages/SocialCostofCarbon.aspx>) for use in resource planning and the CPA, and the initiation of other required rulemaking dockets. Concurrent EIA draft rules are about done and hopefully will be adopted next month. Other areas include the CEIP – how utilities will look at compliance and penalty processes; IRP updated rulemaking – July timeframe; Purchase of Electric (impacts RFPs) draft rules June 1 with comments due end of June with a workshop mid-July; Department of Ecology rulemakings will identify greenhouse gas emission factors; and plenty of other rulemaking activity at the Department of Commerce, the UTC and other agencies.

**Jennifer Snyder:** Thank you. You covered it well. We (Washington UTC) appreciate any comments and participation in the CETA rulemaking process.



## Modeling Process Overview – James Gall

**James Gall:** Aurora in an electric market cost model that is used to simulate the Western Interconnect. It is the industry standard model in the Northwest. Avista implemented Aurora in 2003 and uses it for IRP and rate cases. The inputs include regional loads, fuel prices, resource availability, new resource costs, transmission, and system constraints. Outputs include market prices, energy mix, transmission usage, emissions, power plant margins, generation levels, fuel costs and variable power supply costs to serve loads by year. Market price forecast helps us develop a purchase/sales strategy. The model dispatches to meet hourly loads in each area and tries to match supply with demand or loads and resources. Market price is based on the price for the last, or marginal, plant to turn on for that hour.

**Matt Nykiel (Slide 3):** I have a better understanding of Aurora after participating in the last IRP. For slide 3 inputs and following, I'd like a general understanding of what inputs are public and private in Aurora. *We'll cover some here and there is a slide later that cover more. The database from EPIS is proprietary and they use it for all of their clients who are Aurora license holders. It is largely based on publically available information from EIA, EPA, etcetera, but we can't release it per our license. There are adjustments for Avista including data that will be changed to reflect our contracts, pricing, and operational requirements and how we operate our resource which are proprietary. We'll describe more alter in the presentation.* Thank you.

**James Gall:** Deterministic studies are single point estimates with median hydro and expected loads. They are easy for scenario analyses. Stochastic studies use the expected case or preferred portfolio providing a range of results. The model runs 500 times with different inputs in order to understand risk or volatility. Avista uses the mean value of stochastic analysis for its expected case. Stochastic studies provide better representation of expected value of resources. The model assumptions start from 2020 IRP. We use the same database available from Energy Exemplar today; then update natural gas prices, new resources and retirements, include new laws, review load/resource assumptions for EVs, rooftop solar, new resource costs, add Avista proprietary system info and stochastic distribution of regional hydro, natural gas, wind and loads. We will provide what's not confidential. The Aurora run process-request input will need to be done ASAP, finalize inputs, run long term studies to estimate new resource additions and will show results at next TAC. We will test under 500 simulations and test a future year – 2035. The deterministic run tests reasonableness. The stochastic run takes 3 weeks to run the scenarios. It is a very tight timeline. The outputs will show how profitable each of the resources are to understand dispatch under CETA. This helps us value the cost to serve, estimate emissions, understand changes to the regional market such as volatility, emissions, etc., and the data used for PRISM.

**Matt Nykiel (Slide 7):** You mentioned long-term study. Is this what Avista thinks how the region will meet demand? Is this Avista's interpretation or is it based on other utilities that have their own IRPs? *That's a good question. It's multiple ways. We*

*typically have not utilized other utility's IRPs since they only cover a portion of the area and could be dated. Some utilities don't do IRPs. We look at the region of load obligations, the current resource mix, and state requirements. The model selects new resources for most cost effective for those load areas given our cost assumptions. We have also looked at other studies, consultant data for storage and small renewables. This is a fairly industry standard approach.*

**James Gall:** PRiSM is where all of the models come together from an input perspective to make resource decisions. It is internally developed. We input resource needs and options. The model will select resources that meet needs based on constraints. 'What's Best' is the solver function – min/max of a variable to optimize the value with unlimited variables/constraints. What's Best plus Gurobi speeds up optimization especially when considering so many inputs such as energy efficiency. The outputs include the power supply costs (fixed + variable) and variation; selection of new resources, etc. We design the model to add new resources to serve Washington, Idaho or combined customer requirements. We will split our resource cost using the P/T ratio [35% Idaho and 65% Washington]. States may sell RECs to help recover customer costs.

**James Gall (Slide 10):** The last IRP showed that Colstrip was not cost-effective past 2025. We will reevaluate Colstrip in this plan as no decision has been made. After 2025, since we're splitting by state in PRiSM for the resource balance, Idaho will still receive its 35% share of Colstrip unless it's determined that it will be retired. There is an option to retire in Colstrip in 2025 or in the future.

**Vlad Gutman-Britten:** Does the future year on the chart incorporate potential climate change? *Typically impacts include from climate change include load and hydro. We are open to for 2045 about how climate change impacts these forecasts*

**John Lyons:** Grant [Forsyth] picks these changes up in his load forecast.

**Grant Forsyth:** I try to look at how temperatures change. The approach is a moving average for weather. People can ask more about that during my presentation in the next TAC meeting [August TAC].

**James Gall (Slide 11):** The Social Cost of Carbon (SCC) is required for Washington under CETA. We will run the model to get the expected amount of emissions for each resource. This is for long-term not short-term resources. We will calculate emissions from short-term resources and may cover those at a future TAC. We will not include SCC for biomass or geothermal since those resources are specifically outlined in law, or for Idaho, but we could consider including for Idaho as a scenario if the TAC wants.

**James Gall (Slide 12):** SCC pricing – 2007 \$ and discounted 2.5% (on the lower range). Will use the green line in the chart which starts at \$80 per ton. We move prices from 2007 to 2019 and inflate based on our annual inflation rate of 2.11%.

**James Gall: (Slide 13):** Issues Not Finalized. We may transfer RECs between states, but must determine the price to transfer RECs at. We will need input on if we need to

consider transferring more than 20% if there is an economic benefit. How do we count RECs toward the 80%? Will this be hourly or over the four-year compliance period? If we receive no clarification, we will need to make assumptions to model the IRP. This may be the biggest rulemaking from CETA that the UTC needs to resolve, hopefully in early fall, so it can be modeled correctly for this IRP.

**James Gall (Slide 14):** Reliability planning. We estimate probability of failure to serve all load to a regional standard of 5%. To evaluate whether a portfolio is reliable – PRM (planning reserve margin) is the percentage above the expected load measured by the coldest day of each month averaged by that temperature, load requirement, plus planning margin. This helps us understand how much we can rely on certain resources. The gold standard would be a region wide program with enforced requirements for each utility. Currently, the region is looking at moving toward this model, but probably not in time for this IRP. So, we need to decide how much time we invest in this issue now. ELCC (Electric Load Carrying Capability) – improvement by focusing on additional years, sampling every 5 years, peak credits or peak types. As you add intermittent resources peak value declines. We haven't ran an ELCC for each resource to determine how much the peak contribution reduces over time.

**James Gall (Slides 15 – 17):** Reliability study models to consider. ARAM model is used currently and is customized (not for this IRP). Aurora has ability to dispatch hydro – not as good when the system is stressed leading to over acquisition. Genesis is an option for the future. We can purchase software/hire consultant – this is costly and not currently being looked at. Regional Resource Adequacy Market – could be used for a future option. Two areas of focus are ARAM and Aurora – likely our current model with a single year and possibly scenarios, but we can't commit to every year, use 2020 ELCC (peak credits) scenario on resource adequacy. We will keep the TAC updated throughout the process.

**James Gall (Slide 18):** Data availability – proposal, we are interested in feedback for. Avista-specific data and Energy Exemplar database is proprietary, prices, regional emissions, not dispatch (confidential), high level results including PRiSM, won't be able to make inputs and resolve (requires license), big change from prior IRPs, load forecast models are confidential because of customer-specific information. We will provide monthly energy/peak results by state, resource costs (you already received); demand-side data will include a list of energy efficiency programs available, may not be fully available in July/August so we may have a short, 1-hour workshop when that data becomes available. DR programs and their potential. Transmission/distribution models are confidential and will be a TAC 3 discussion. Reliability – ARAM requires a license so you can't input and resolve, but we are researching to ensure we can make it available.

**Michael Eldred:** I have a question of how you are testing for reliability. *LOLP in 2035, 500 times in that year. The percent probability load not met. The goal is 95% meeting in all times. In most cases it does. If results are grossly inadequate and outside the margin of error, we rerun the study. Does that help?* Yes, thank you.

**Matt Nykiel:** LT study, when Avista is looking over a range of resources is it taking into account things like customer owned generation over time as roof top solar reduces demand on IOUs? *Good question. Slide 6 specific adjustment made to model. We will present assumptions in the market price meeting. Definitely an area we will have to consider.*

**Matt Nykiel:** Recall that was an analysis for Avista, but how meeting regional WECC loads but in area. *Yes, we look at both inside Avista and outside the service territory. Looking to point to the right spot in the last IRP. Typically not a lot of discussion. It is a small but important input. Will definitely talk about it in the next TAC.*

**James Gall:** I appreciate the better interaction on these questions.

**Tina Jayaweera:** I'm interested in more about emissions savings in energy efficiency and demand response. *DR is challenging and depends on program – some reduce and some shift loads, and the likelihood of a DR program being called on based on program design could be a challenge. Energy efficiency typically uses an hourly profile of savings compared to hourly emissions from Aurora – possibly could run a scenario to see how emissions change by the hour. We can do this for the deterministic but not all 500 runs. Could show incremental savings.*

**Dainee Gibson:** A lot of CETA requires the model to be able to split differences geographically. Can Aurora split it by state or does it apply to the entire service territory? *Sure. We could split it by state, but it doesn't model the physics well. Now we talk about region as a whole. The OWI bubble in Aurora can't split by state really well, since the system doesn't recognize state boundaries. Avista in PRiSM is where we talk about how we split resources by state from a resource planning perspective.*

**Kevin Key (Slide 10):** I understand the 65/35 split historically, but it appears incremental legislation in Washington may split differently. *Maybe the model equals 65/35 for existing resources and the split of new resources are an output of the model. I don't want to volunteer you for a bunch of runs, but want to understand how it might change. We may shift from a cost to a load balance.*

**Vlad Gutman-Britten:** CETA requires 100% in 2045, but Avista corporate goal is 100% by 2027. How do you account for that? *Excellent question. If cost effective, we will do it. Will run a scenario to meet the goal and it becomes a management decision on reaching 2027 and 2045 goals to set the strategy going forward based on the cost to customers. Last IRP, we were 90% clean without additional costs beyond CETA. At that time, management was not willing to put that additional cost on customers for the remaining 10 percent.*

**Matt Nykiel:** In PRiSM, are there parameters that require Avista service territory to meet the goal in 2027 and 2045 for the entire service territory? Carbon neutral by 2027 and 2045 is not meaningful if not cost effective from the get go. I don't understand the goal if it doesn't have an impact

**Jason Thackston:** Good question and the point is appreciated. I appreciated the way James answered. What we said, and are still committed to, is affordability and reliability. We are still committed to those goals, but reliability will not be sacrificed and the goal is subject to affordability by the impact on customers' bills. We always look at cost-effective, but trying to be more holistic. Does that help?

**Matt Nykiel:** I'd like to learn more.

**Terri Carlock:** To clarify, you will run the full system to meet that commitment and looking at the costs separately for both states to decide whether you implement in both states and the Commissions will each review. *That is a fair and correct summary. Still need guidance by states before we can fully state how we model.*

**Vlad Gutman-Britten** – Are you selling REC between states? *About ready to talk about that. If 20% REC only or bundled. Idaho to Washington for Rulemaking is still being considered relative to this and bundling so I can't answer specific questions on how we'll be modeling until the rulemaking is more final. We will likely try to simulate REC sales similar to our last plan.*

**Vlad Gutman-Britten:** So Idaho would have a higher fossil fuel content than Washington? *Correct.*

**Matt Nykiel (Colstrip):** What does it mean to have a shareholder portfolio? One question, I don't understand why if Units 3 and 4 are uneconomic, why is the Washington share only going to shareholders? *Need to model it to decide where it goes. We are redoing same analysis so the Idaho portion only serves their load. If the model chooses 2025, or another date, to close for economics. The shareholder portfolio is because it can't be in Washington rates after 2025 under CETA, but if it is still operating, we still have to sell off or consume those megawatt-hours.*

**Jason Thackston:** Correct me if what I say is incorrect. There are two outcomes. One. Assume all same as last IRP, after 2025 Colstrip is not in the portfolio because it is not economic. Two. Very extreme. Everything doubles and Colstrip is way in the money, it should still be in the portfolio beyond 2025, but it is not viable in Washington. It would still be, absent a decision to shut down the plant. Nuance in Washington State the model has to reflect.

**Matt Nykiel:** That's helpful. Thank you.

**Terri Carlock:** What shareholder portfolio costs would be associated for any costs extending the life of the plant? *Washington depreciation done in 2025 for Colstrip. Any other O&M, capital, or fuel at that time will be on shareholders. Washington will still cover their shutdown costs for the time it was on their system.*

**Matt Nykiel (Slide 10 – PRiSM):** I don't mean to belabor the point, first bullet point, does it respect state guidelines? How will the model in practice split up new resource? *We don't have all the answers regarding specific actual operations. From a modeling*

*perspective for adding or subtracting resources we continue to operate as a whole system. Operations is as a single system. From a clean energy perspective, we can assign whether or not power is clean, etcetera on an accounting basis not a physics basis. Accounting rather than an engineering basis. Appreciate more discussion in the future.*

**Terri Carlock:** *Same for market purchases? Still rules to come. I hope regulating bodies don't rush it because of lasting impacts of the decision.*

**Jennifer Snyder:** *Are you including social cost of carbon on new construction and operation of new or existing resources? Just new, but there are there processes at the generation site that add to emissions. Trucks for hauling fuel at Kettle Falls and other equipment, trucks to maintain wind farms. NREL has some older studies estimating these types of emissions as well.*

**Matt Nykiel:** *SCC is a reflection of the understanding of GHG cost not being internalized by facilities that emit them. Is Avista incorporating this cost due to the legal requirements not because Avista is acknowledging that GHG have a cost that's not being internalized? Its Avista's understanding of a cost just as a legal operation, not as a corporate entity. Makes sense. One way to interpret it.*

**Jason Thackston:** *I'm not sure I'm the best one to answer, but generally speaking you have captured it for Washington legislation and Washington feedback.*

**Tina Jayaweera:** *Upstream value for emissions? Next TAC meeting, but Avista gas line rights are very different than the distribution side. We source our gas mostly from Canadian sources so we're focusing on the emission for the gas we're sourcing.*

**Jennifer Snyder:** *Issues not finalized, what date do you need clarification by for RECs/CETA? REC transfers by September [2020] at the latest. Earlier is better. If not clarified by then, we would run multiple scenarios or possible outcomes.*

**Matt Nykiel:** *Bundled RECs, can Avista transfer energy plus RECs associated with that? Multiple interpretations of the options. Power, REC, power plus REC or separate the two and combine with others. The way bundled or not is the difference for Washington CETA in different contexts. Depending on how WUTC rules, we could have to way overbuild because of REC needs. Treat as I-937 or actually serve instantaneously.*

**Rachelle Farnsworth:** *So can you tell more on how and why it is Washington establishing the price of REC transfers between states? Hopefully I didn't say that. Washington sets the requirement for how many RECS are required. Then it is a question of what price is needed to meet Washington law. I.e., the price is \$20 so the model says build for Idaho to sell to Washington. Price matters depending on outcome in model. Much as last time, if economic to build for state and take advantage of the market if available. Three examples at different prices: example price of a REC at \$20, Idaho should build a project to sell to Washington. If valued at \$0, Idaho wouldn't build.*

*We wouldn't want to see the model build based on resources to sell to Washington, but would build the least cost to take advantage of the market.*

Kevin (IPUC) – have you defined requirements for Reliability modeling (document would be helpful)? James - slide 14 95% of simulations serve 100% load and reserve requirements; don't want to start down the path of buying new software if the regional market is coming soon

**Kevin Keyt (Slide 14):** *Have you defined requirements for reliability models and decision making? 95% LOLP of simulations serve 100% of load requirements and we look at other metrics too. In terms of software development and modeling tool, we want to produce some confident results. There is a cost to maintain/operate a reliability model. Timeline is short for this plan, so we don't want to go too far if a resource market overseer is coming. Maybe the new Genesis model. Maybe a new overseer. Don't want to have to scrap a new model in a year or two.*

### **Modeling Process Overview Continued After Lunch Break – James Gall**

**Matt Nykiel:** *I appreciate the transparency. I notice it in the slides already. For Aurora, I'd like to understand Colstrip inputs better. If Units 3 or 4 continues to be uneconomic for Idaho from modeling, how would the Idaho share go into a shareholder portfolio? Aurora gives a price forecast valuing resources not by ownership. Dispatch the plant with a heat rate and fuel costs that influence market price if economic to run. If PRiSM is not cost effective, do we retire or close the plant? If it goes out, need to decide how – if closed or sold. PRiSM more utility based.*

**Matt Nykiel:** *Make sure the model is looking at price to meet minimum take obligations. If it becomes uneconomic for Idaho, does the IRP consider where that minimum energy goes? If it goes out of the Idaho portfolio, it jumps from planning to action. If we remove it from Idaho, Idaho no longer bears the expense. We reevaluate it at every IRP cycle. Nothing changes here from how we model in last IRP*

**Matt Nykiel:** *Mentioned earlier it accounts for shut down, forced outages and needed repairs. Unit 4 is expected to need repairs to the super heater. Does the model account for those expected repairs? This can affect ownership issues not agreed to under sections of the contract. I can't and maybe shouldn't comment on a contract. It includes expected and potential repairs.*

### **Generation Resource Options – Lori Hermanson**

**James Gall:** *We are seeking feedback from the TAC about if we should model generic or specific resources regarding pumped hydro storage.*

**Jennifer Snyder:** *Don't have rates impact now. But lean towards specific projects if data available.*

**Terri Carlock:** *Doesn't pumped hydro storage depend on scale?*

**James Gall:** A generic resource would need an assumption for duration and cost. Hybrid concept we used last time. But some projects have attributes with lower or higher costs. We got comments last time from some TAC members. We modeled one specific pumped hydro resource and some TAC members thought we should have modeled others. Then what about specific wind and solar projects? That means we are doing an RFP in an IRP.

**Kathleen Kinney:** I have some sources on renewable hydrogen gas you can email me about. *We will email you. Renewable natural gas will be discussed in the next TAC meeting.*

**Amy Wheeless:** I acknowledge the conundrum. Did you reach out to the renewable hydrogen alliance? *We did not. We used Black & Veatch last time. Also had comments from a vendor on gas turbine retrofits for hydrogen gas.*

**Matt Nykiel (Slide 3):** Can you explain what in the analysis that caused gas prices to increase. *2020 is an estimate of 2022. Mostly inflation and the price of gas. They are effectively the same.*

**Matt Nykiel (Slide 10):** What is the northwest for solar? Southern Idaho? Are we looking at Idaho? *Southern Idaho or Oregon with a BPA wheel to get to Avista. We are indifferent on location, this is showing the costs and benefits of solar in a better location.*

**Jørgen Rasmussen:** Is liquid air storage included? *Yes, see slide 7, we are modeling it again. It was selected in the last plan.*

**Thomas Dempsey:** We will be reviewing the liquid air energy storage costs further in this plan.

#### **Review of spreadsheet with resource costs and operating characteristics:**

**James Gall:** I've been involved with half a dozen RFPs. Prices vary widely and will be different than the generic modeled prices. We are really seeking input on these costs and assumptions.

**Vlad Gutman-Britten:** Environmental burdens are a wider scope, not just greenhouse gas emissions.

#### **Washington Vulnerable Populations and Highly Impacted Communities – James Gall**

James Gall: Vulnerable populations consider socioeconomic factors and income sensitivity factors. Avista already recognizes that nearly half of our territory is low income and we are economically involved in our communities. This part of CETA is currently in the rule-making process. We hope the TAC and other advisory groups will help guide us in how to address these new requirements. It is possible a new advisory group is needed or we may get more participants in the current TAC or another group.



We need to gather more data and better understand our baseline – where are they at today? The Washington State disparities map rates each census tract between 1 and 10 for socioeconomic factors which seems to align with the proposed rules. We are proposing score of 8 or higher to be considered vulnerable or impacted. We will overlay this on our service territory, noting that Idaho is not subject to CETA. There are overlapping service territories with other utilities in some of the vulnerable areas. Average use per customer – two sets and compare how they change over time. We use that information to estimate how costs can change over time. Whether or not customers have more than 6% of their income goes toward energy. Should the IRP have a monetary preference for these areas, no preference, or no additional preferences?

Reliability/Resiliency metrics are available by feeder. We can show this at a future TAC meeting and compare to the remaining areas. There is a challenge for how this relates to the IRP. For Resource analysis, we can estimate emissions from our facilities located near or removed from these areas. If a new resource, we can discuss how those may change in those areas. Energy security is challenging. The grid works together for the benefit of all customers, not necessarily for certain populations.

**Kate Griffith:** Regarding DOH map. The state Environmental Justice Taskforce is working on guidance as the mapping tool is being developed among other tasks. They have regular meetings. More info is here:  
<https://healthequity.wa.gov/TheCouncilsWork/EnvironmentalJusticeTaskForceInformation>.

**Vlad Gutman-Britten:** Note that the tracts aren't categorized in a population weighted way, so the three most impacted deciles of tracts may not correspond to the three most impacted deciles of people.

**Jennifer Snyder (Slide 7):** No good updates to add [concerning the identification of highly impacted communities or vulnerable populations].

**Amy Wheelless:** How do you define community? *Identified by census tract, so each colored area in Slide 10 is a community.*

**Vlad Gutman-Britten:** It would be helpful to understand how community compares to population and customer share and load share. *Excellent questions. We're going to get to that in metrics.*

**Shawn Bonfield (Slide 14):** What do the figures on the map represent? *The numbers are census tracts and the darker shaded areas are more vulnerable.*

**Kate Griffith:** Do you have a sense for the particular sensitivity factors in Spokane? I apologize, I mean the issues they face such as low birth rates, etc. *I don't know that information.*

**Vlad Gutman-Britten:** The Department of Health map provides component scores, in addition to the rolled up score. *Thank you.*

**Amy Wheelless:** Some of the CAP [Community Action Partnership] agencies may be able to provide more qualitative information.

**Vlad Gutman-Britten:** Yes, monetary preference and extra inducements are important and would go toward equalizing going forward since they haven't received these resources in the past. Equity is worthwhile to perform and pursue. How much is required? Think about what will be necessary for success.

**Kate Griffith:** How is Avista working to contact and engage with these communities around planning? Have you started reaching out to these groups or communities? *We need direction. Are these separate advisory groups. We have had some participation in the past on the TAC from tribes and SNAP. They are not always able to attend. We need to reach out to public officials in these areas and need more outreach and opportunities to include these groups. More to come on this.*

**Jennifer Snyder:** What metrics make sense? It would be helpful to have more representation from these groups for these particular committees to understand what issues to address.

**Corey Dahl:** I'll second conducting outreach. What does it look like? How to address equity? The company has both an obligation to select the lowest cost resource, but a need to comply. Example off the top of my head not sure if real. Natural gas generation facility goes offline and is replaced with solar benefits to the surrounding community, but also benefits of transmission. But jobs are lost.

**Jennifer Snyder:** What type of long- and short-term public health benefits have you looked at? Potentially for DSM and supply-side resources? *Example, wood smoke in energy efficiency. Including things from a TRC point of view. Concentrate on emissions with existing generation. Are there others?*

**Jennifer Snyder:** There are things we didn't take into consideration prior to CETA, but we should. There are a lot of health benefits in some jurisdictions. Not in Washington yet, but new things not taken into account before CETA.

**James Gall:** One other is interplay of gas and electric service territory.

**Amy Wheelless:** The past few slides spurred a lot of thoughts. I'm not really involved with the CETA rulemaking. Great questions to bring forward. Seek potential future and get cost benefits.

**James Gall:** Can look at distribution or opportunities that might be higher cost, but see what those costs might be. The topic will come up again to show some of these metrics. Let John [Lyons] or myself know of any thoughts you have.

**Kate Griffith:** Are these the metrics you're planning to bring into the CEIP? *So far. We may have additional metrics later with input. Meaningful and calculable metrics for a more useful set of data.*

**Kate Griffith:** You mentioned quantifiable, but non quantifiable is also a big piece of this so I'd be interested to hear more about incorporation of less measurable equity measures. *We are looking for any ideas we can look at.*

Meeting adjourned.



*2021 Electric Integrated Resource Plan*  
**Technical Advisory Committee Meeting No. 2 Agenda**  
**Thursday, August 6, 2020**  
**Virtual Meeting- 9:00 AM PST**

<b>Topic</b>	<b>Time</b>	<b>Staff</b>
Introductions & IRP Process Updates	9:00	Lyons
Natural Gas & RNG Market Overview	9:30	Pardee
Break	10:45	
Natural Gas Price Forecast	11:00	Brutocao
Lunch	11:30	
Upstream Natural Gas Emissions	12:30	Pardee
Break	1:30	
Regional Energy Policy Update	1:45	Lyons
Natural Gas and Electric Coordinated Study	2:15	Gall/Pardee
Highly Impacted & Vulnerable Populations Baseline Analysis	3:00	Gall
Adjourn	3:45	



# 2021 Electric and Natural Gas IRPs TAC Introductions and IRP Process Updates

John Lyons, Ph.D.  
Second Technical Advisory Committee Meeting  
August 6, 2020

# Updated Meeting Guidelines

- Gas and electric IRP teams working remotely, but still available by email and phone for questions and comments
- Some processes are taking longer remotely
- Virtual IRP meetings until back in the office and able to hold large group meetings
- TAC presentations, notes, work plans and past IRPs are posted on joint IRP page for gas and electric:  
<https://www.myavista.com/about-us/integrated-resource-planning>

# Virtual TAC Meeting Reminders

- Please mute mics unless speaking or asking a question
- Use the Skype chat box to write questions or comments or let us know you would like to say something
- Respect the pause
- Please try not to speak over the presenter or a speaker who is voicing a question or thought
- Remember to state your name before speaking for the note taker
- This is a public advisory meeting – presentations and comments will be recorded and documented

# Integrated Resource Planning

- Required by Idaho, Oregon and Washington\* every other year
- Guides resource strategy over the next twenty + years
- Current and projected load & resource position
- Resource strategies under different future policies
  - Resource choices
  - Conservation measures and programs
  - Transmission and distribution integration for electric
  - Gas distribution planning
  - Gas and electric market price forecasts
- Scenarios for uncertain future events and issues
- Key dates for modeling and IRP development are available in the Work Plans



# Technical Advisory Committee

- The public process piece of the IRP – input on what to study, how to study, and review of assumptions and results
- Wide range of participants involved in all or parts of the process
  - Ask questions
  - Help with soliciting new members
- Open forum while balancing need to get through all of the topics
- Welcome requests for studies or different assumptions.
  - Time or resources may limit the number or type of studies
  - Earlier study requests allow us to be more accommodating
  - **August 1, 2020** was the electric study request deadline
- Planning teams are available by email or phone for questions or comments between the TAC meetings

# 2020 Electric IRP Meetings – IPUC

- AVU-E-19-01 <https://puc.idaho.gov/case/Details/3633>
- Telephonic public hearing on August 5, 2020
- August 19, 2020 comment deadline, September 2, 2020 response
- Overview of topics discussed at July 9, 2020 virtual public workshop:
  - Moving away from coal
  - Cost impacts for Idaho customers from Washington laws
  - IRP procedural questions about acknowledgment of the IRP
  - Climate change questions and timing of actions
  - Colstrip: decommissioning, other owners, cost sharing with Washington
  - Consideration of social costs/externalities and public health
  - Support for clean energy and Commission authority to require it
  - Resource timing
  - Risks considered in the IRP: economic, qualitative and climate
  - Idaho versus Montana wind locations
  - Maintaining Idaho RECs
  - Climate change law applicability and lawsuits

# 2021 Natural Gas IRP TAC Schedule

- TAC 1: Wednesday, June 17, 2020
- **TAC 2: Thursday, August 6, 2020 (Joint with Electric TAC)**
- TAC 3: Wednesday, September 30, 2020
- TAC 4: Wednesday, November 18, 2020
- TAC 5: February 2021 – TAC final review meeting if necessary
- Natural Gas TAC agendas, presentations and meeting minutes available at: <https://myavista.com/about-us/integrated-resource-planning>

# 2021 Electric IRP TAC Schedule

- TAC 1: Thursday, June 18, 2020
- **TAC 2: Thursday, August 6, 2020 (Joint with Natural Gas TAC)**
- Economic and Load Forecast, August 2020
- TAC 3: Tuesday, September 29, 2020
- TAC 4: Tuesday, November 17, 2020
- TAC 5: Thursday, January 21, 2021
- Public Outreach Meeting: February 2021
- TAC agendas, presentations and meeting minutes available at:  
<https://myavista.com/about-us/integrated-resource-planning>

# Process Updates

## Economic and load forecast delay

- Special meeting 1:00 – 3:30 pm PST on Tuesday, August 18 or Wednesday, August 19, 2020 to cover the forecasts

## AEG Conservation Potential Assessment and Demand Response Studies – delayed from TAC 2

- AEG has developed baseline assumptions, market profiles and energy/gas use per customer
- Market data has been collected and compiled
- Measure Assumption development is complete
- Compiled 2021 Power Plan Assumptions
- Measure List is in-process and is expected to be available mid-September
- CPA discussion with TAC – September TAC meeting.

# Today's TAC Agenda

9:00 – Introductions & IRP Process Updates, Lyons

9:30 – Natural Gas & RNG Market Overview, Pardee

10:45 – Break

11:00 – Natural Gas Price Forecast, Brutocao

11:30 – Lunch

12:30 – Upstream Natural Gas Emissions, Pardee

1:30 – Break

1:45 – Regional Energy Policy Update, Lyons

2:15 – Natural Gas and Electric Coordinated Study, Gall/Pardee

3:00 – Highly Impacted & Vulnerable Populations Baseline  
Analysis, Gall

3:45 – Adjourn



# Natural Gas Market Overview

Tom Pardee, Natural Gas Planning Manager  
Second Technical Advisory Committee Meeting  
August 6, 2020

# Units

Common Gas Units			
	1 Bcf	1 Dth	1 Therm
kWh	302,062,888	293.001	29.300
MWh	302,063	0.293	0.029



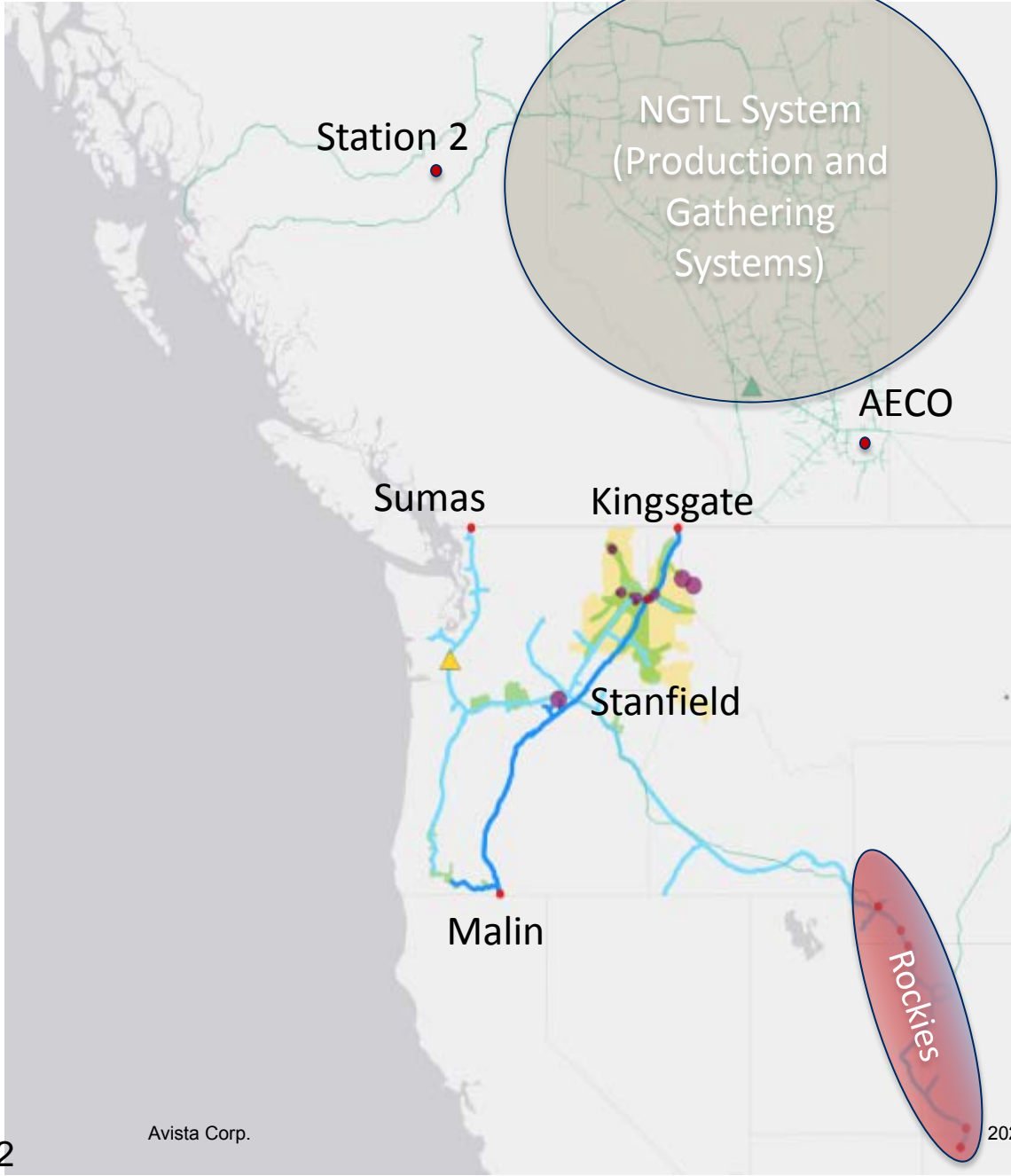

Avista Electric Territory

Avista Natural Gas Territory

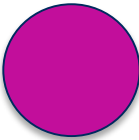

Electric Power Plants



Gas Transmission Network



Northwest Pipeline



Receipt Point



Jackson Prairie Storage (LDC Owned)

# Avista's Supply

- Natural Gas LDC Side
  - 10% contracted from US supply basins
  - 90% contracted from Canadian supply basins
- Electric Side
  - 100% contracted from Canadian supply basins

# US Demand

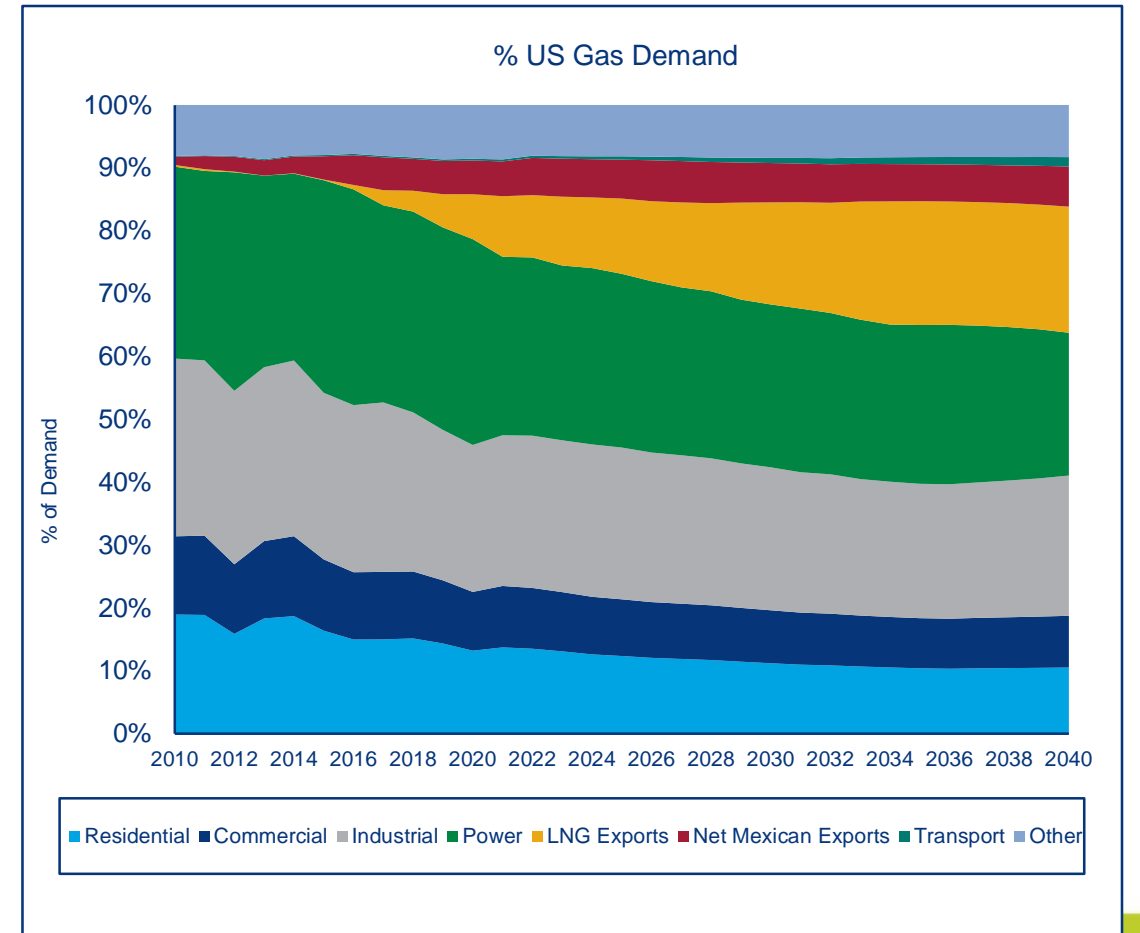
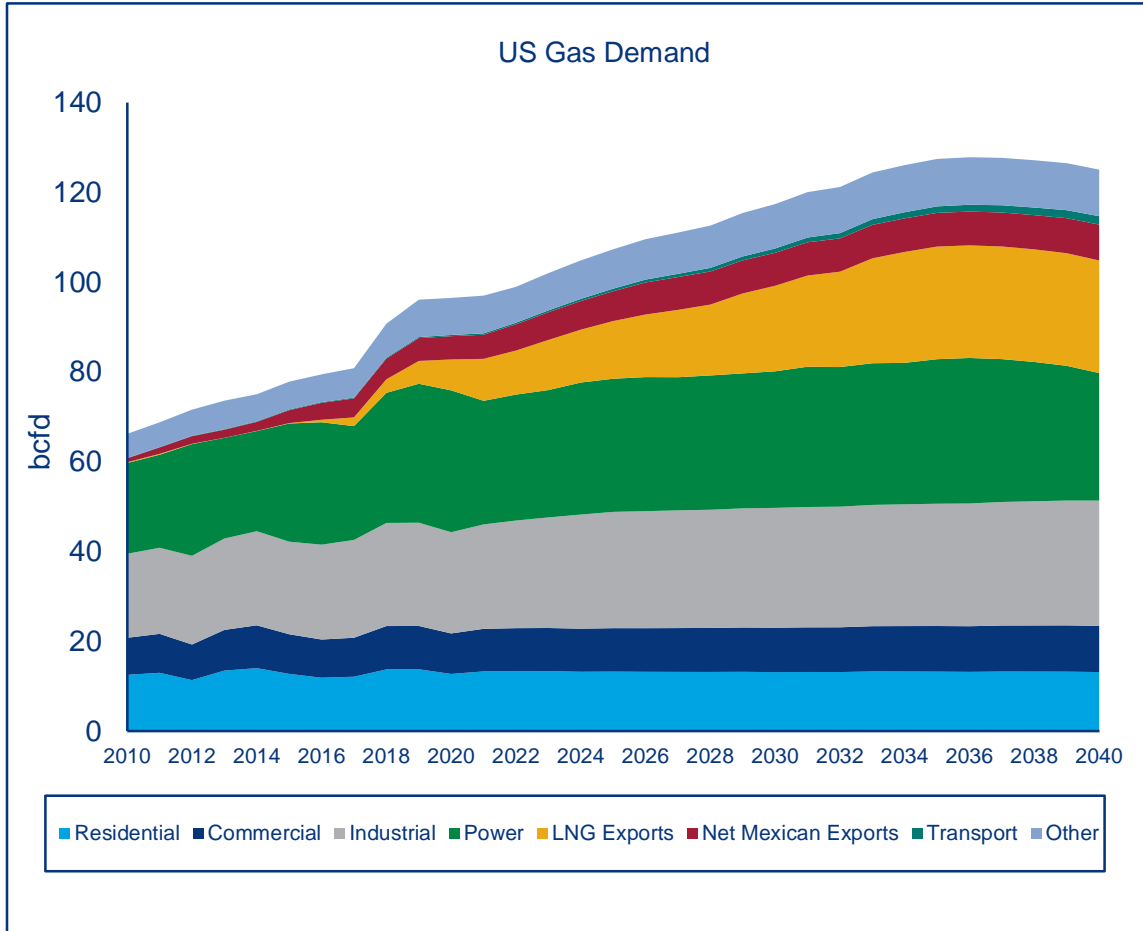

# US Supply

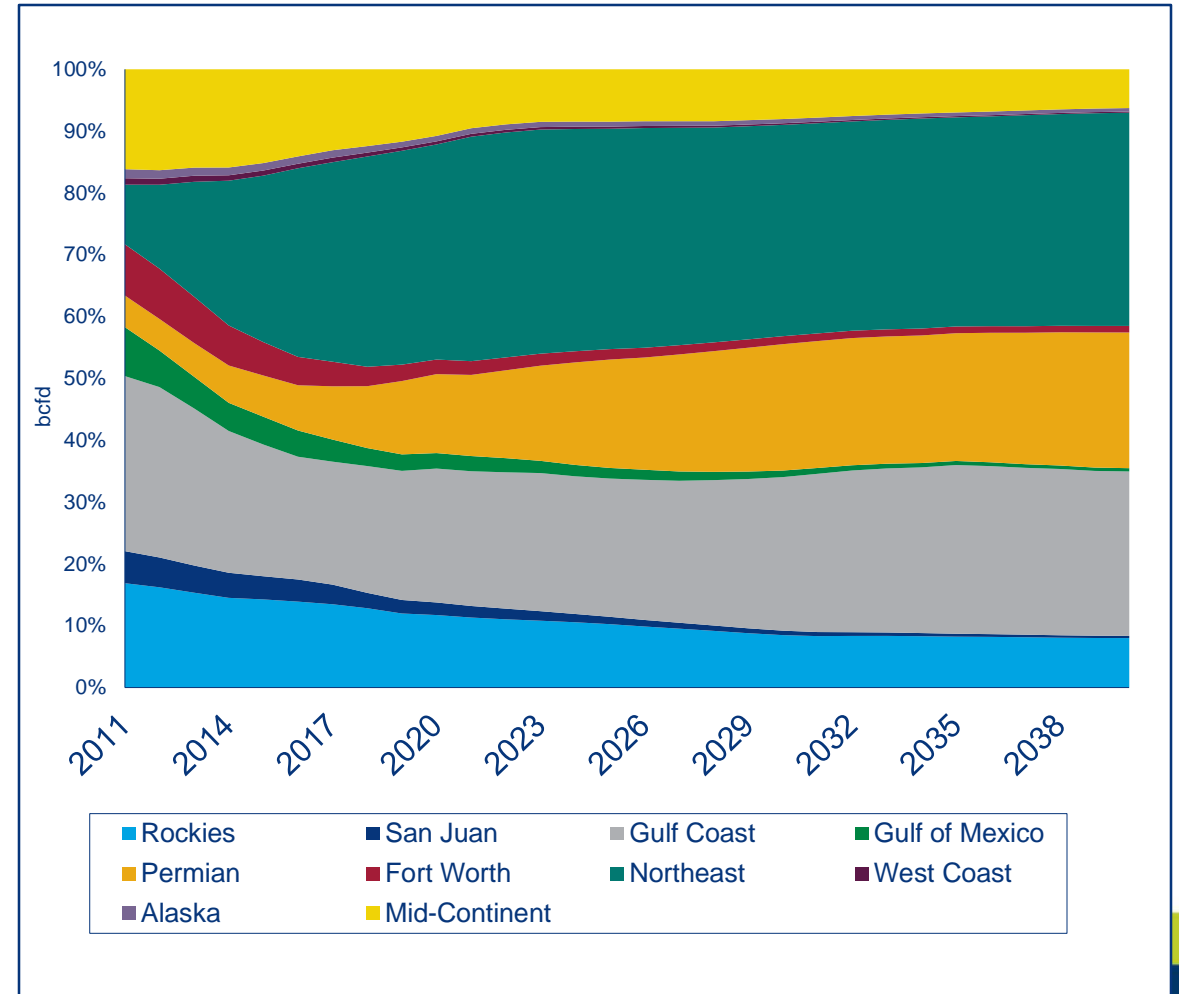
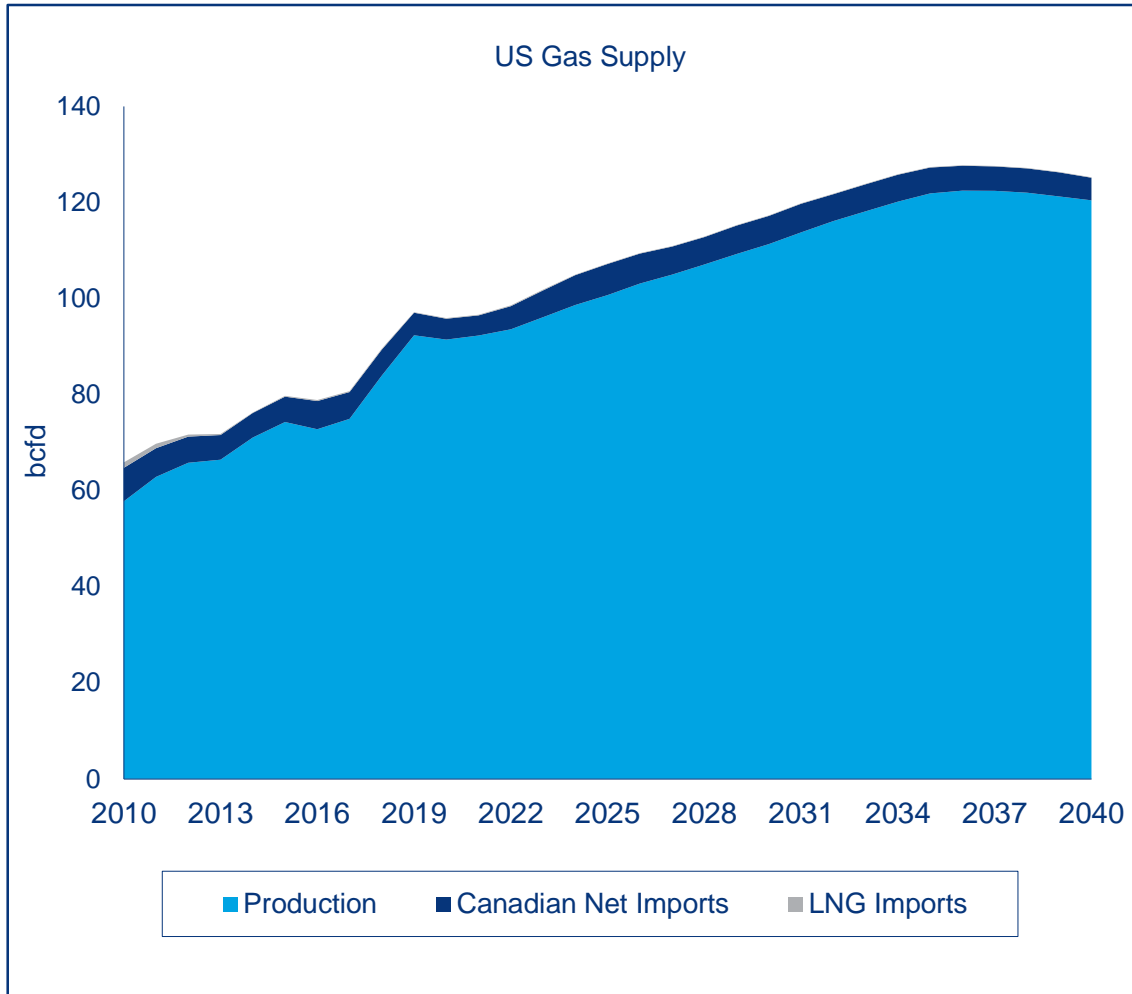

# Canadian Supply and Demand

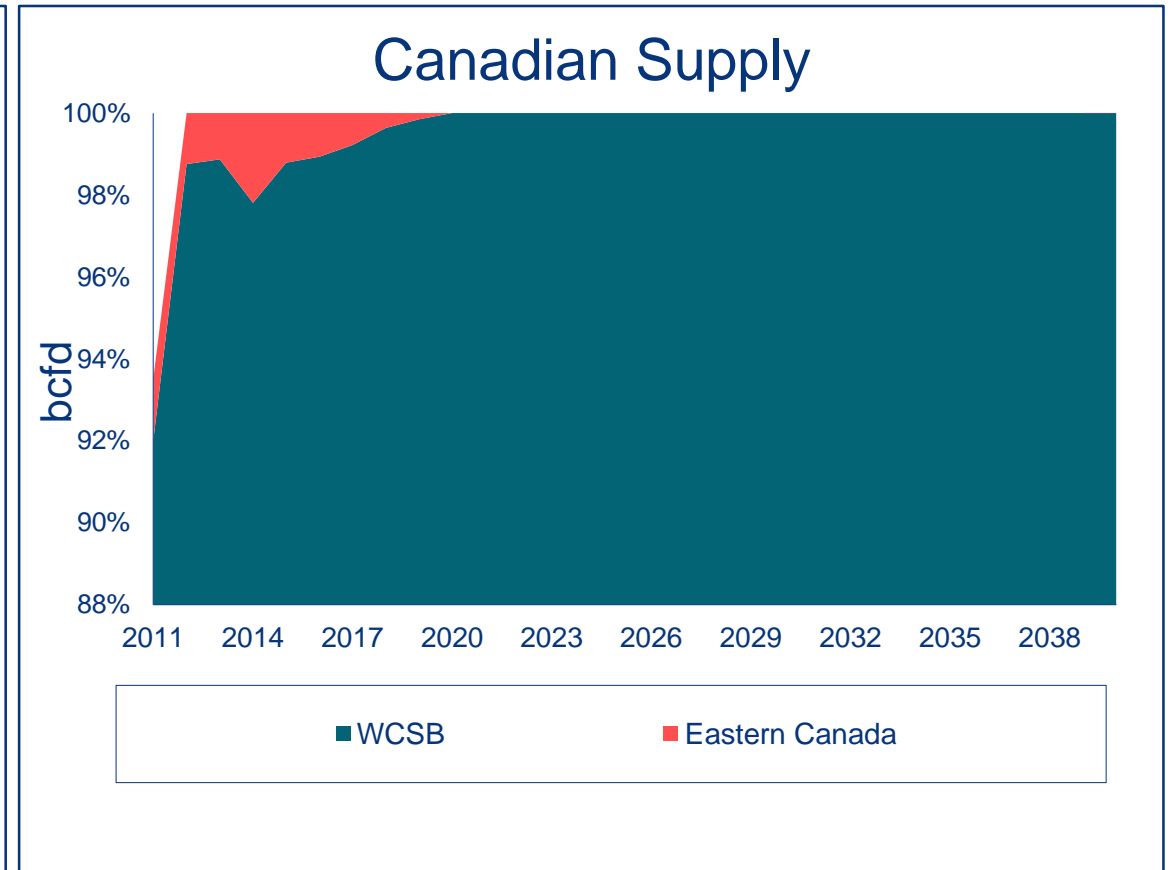
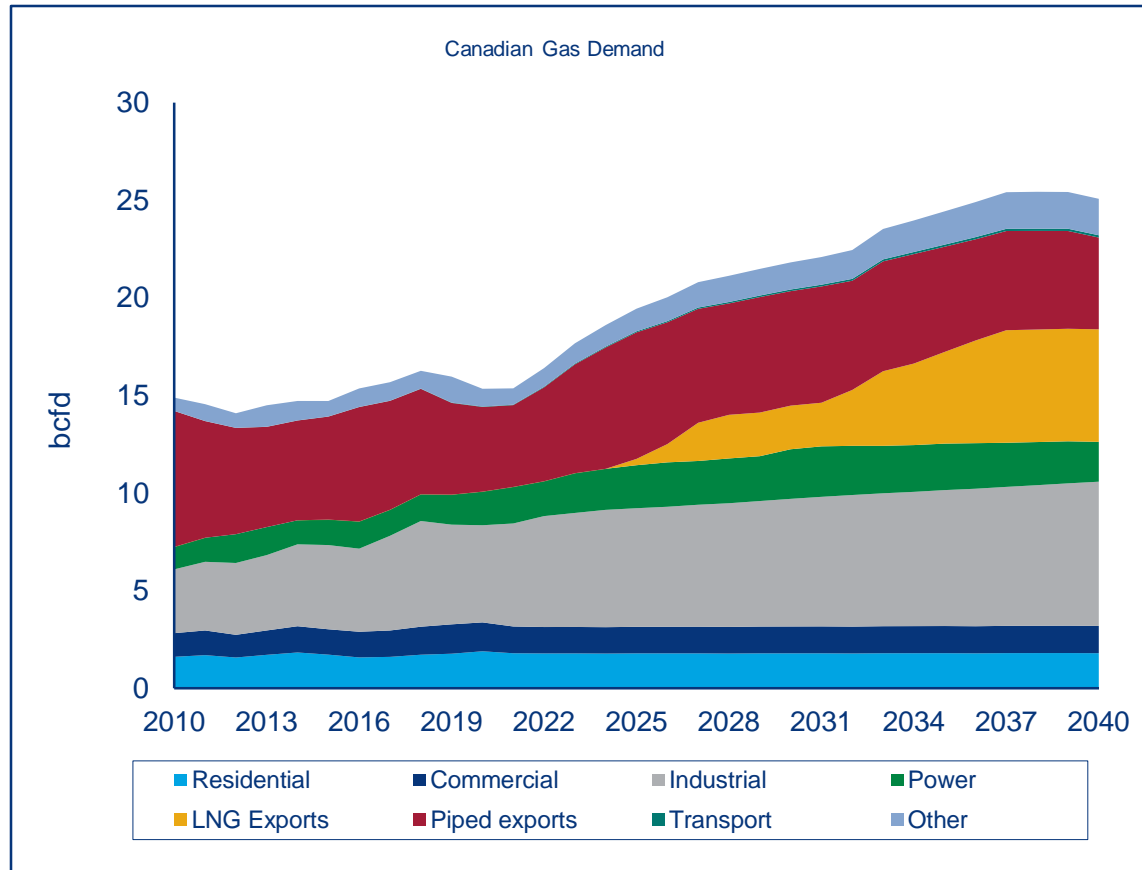



# North American LNG Export Terminals

## Approved, Not Yet Built

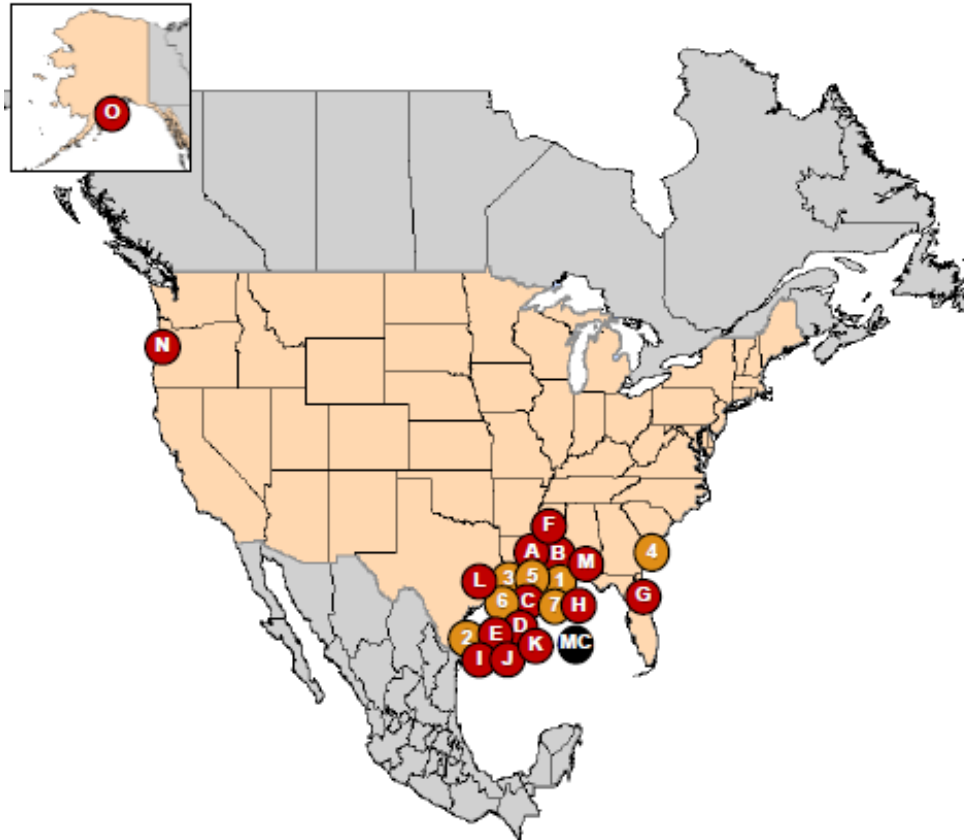

### Export Terminals

#### UNITED STATES

##### APPROVED - UNDER CONSTRUCTION - FERC

1. Hackberry, LA: .71 Bcfd (Sempra-Cameron LNG Train 3) (CP13-25)
2. Corpus Christi, TX: 0.72 Bcfd (Cheniere-Corpus Christi LNG Train 2) (CP12-507)
3. Sabine Pass, LA: 0.7 Bcfd Train 6 (Sabine Pass Liquefaction) (CP13-552)
4. Elba Island, GA: 140 MMcfd (Southern LNG Company Units 7-10) (CP14-103)
5. Cameron Parish, LA: 1.41 Bcfd (Venture Global Calcasieu Pass) (CP15-550)
6. Sabine Pass, TX: 2.1 Bcfd (ExxonMobil - Golden Pass) (CP14-517)
7. Calcasieu Parish, LA: 4.0 Bcfd (Driftwood LNG) (CP17-117)

##### APPROVED - NOT UNDER CONSTRUCTION - FERC

- A. Lake Charles, LA: 2.2 Bcfd (Lake Charles LNG) (CP14-120)
- B. Lake Charles, LA: 1.08 Bcfd (Magnolia LNG) (CP14-347)
- C. Hackberry, LA: 1.41 Bcfd (Sempra - Cameron LNG Trains 4 & 5) (CP15-560)
- D. Port Arthur, TX: 1.86 Bcfd (Port Arthur LNG Trains 1 & 2) (CP17-20)
- E. Freeport, TX: 0.72 Bcfd (Freeport LNG Dev Train 4) (CP17-470)
- F. Pascagoula, MS: 1.5 Bcfd (Gulf LNG Liquefaction) (CP15-521)
- G. Jacksonville, FL: 0.132 Bcfd (Eagle LNG Partners) (CP17-41)
- H. Plaquemines Parish, LA: 3.40 Bcfd (Venture Global LNG) (CP17-66)
- I. Brownsville, TX: 0.55 Bcfd (Texas LNG Brownsville) (CP16-116)
- J. Brownsville, TX: 3.6 Bcfd (Rio Grande LNG - NextDecade) (CP16-454)
- K. Brownsville, TX: 0.9 Bcfd (Annova LNG Brownsville) (CP16-480)
- L. Corpus Christi, TX: 1.86 Bcfd (Cheniere Corpus Christi LNG) (CP18-512)
- M. Sabine Pass, LA: NA Bcfd (Sabine Pass Liquefaction) (CP19-11)
- N. Coos Bay, OR: 1.08 Bcfd (Jordan Cove) (CP17-494)
- O. Nikiski, AK: 2.63 Bcfd (Alaska Gasline) (CP17-178)

##### APPROVED - NOT UNDER CONSTRUCTION - MARAD/Coast Guard

- MC. Gulf of Mexico: 1.8 Bcfd (Delfin LNG)

#### CANADA

For Canadian LNG Import and Proposed Export Facilities:

<https://www.nrcan.gc.ca/energy/natural-gas/5683>

As of May 29, 2020

**U.S. Jurisdiction & Status**

- FERC - Approved, Under Construction
- FERC - Approved, Not Under Construction
- MARAD / U.S. Coast Guard



# North American LNG Exports

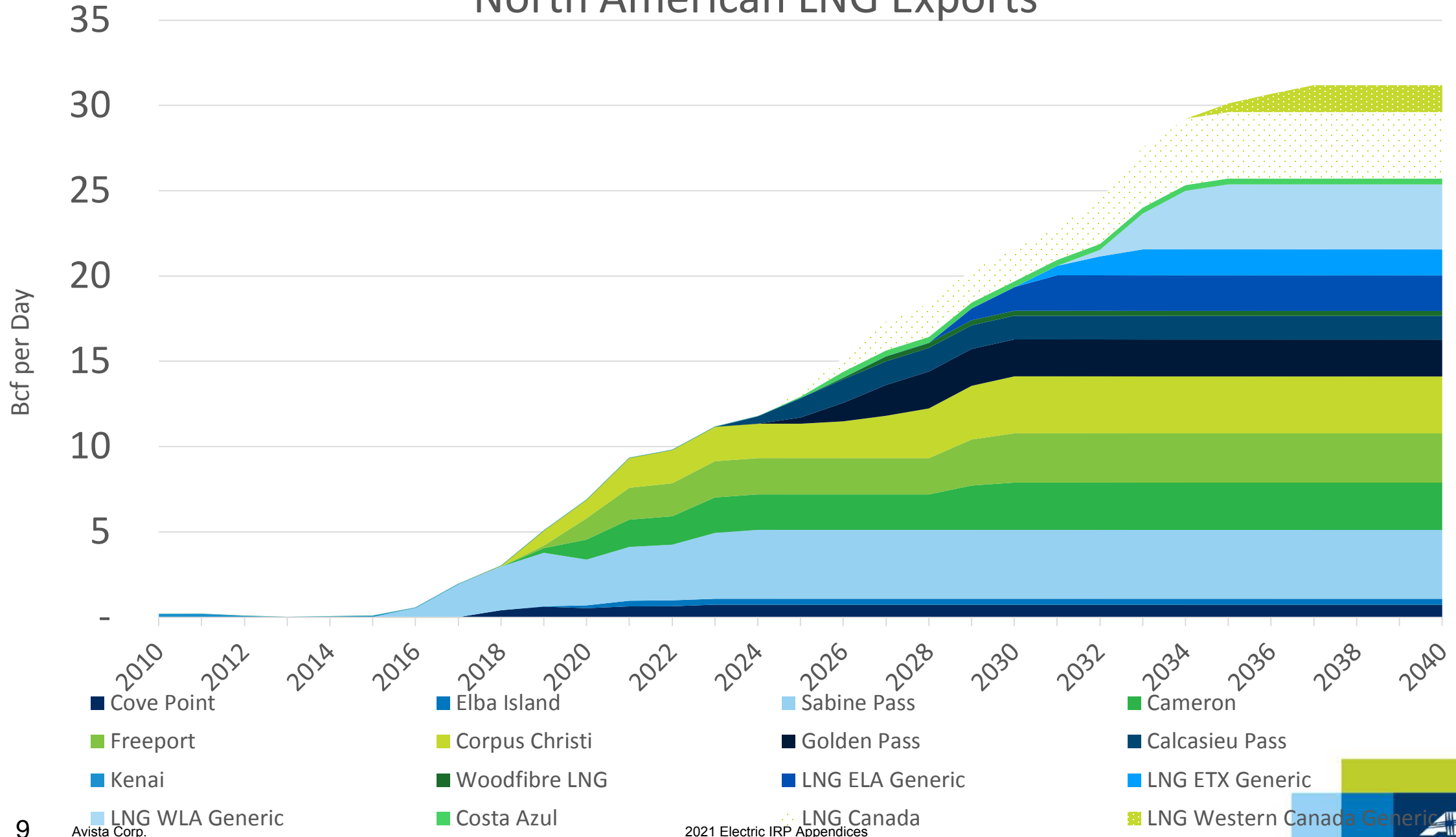

# West

Total Demand by Census Region

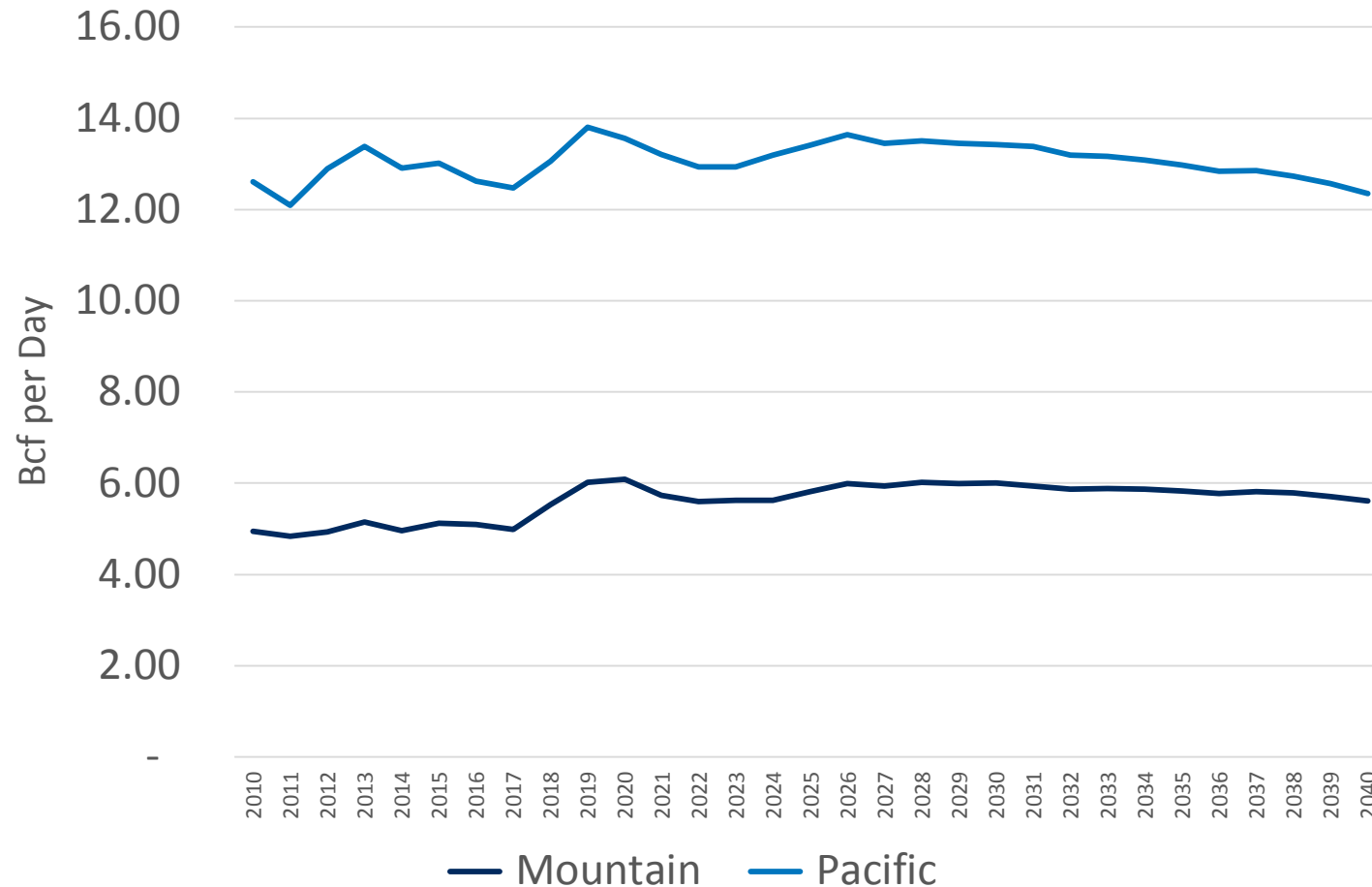

Census Region Map

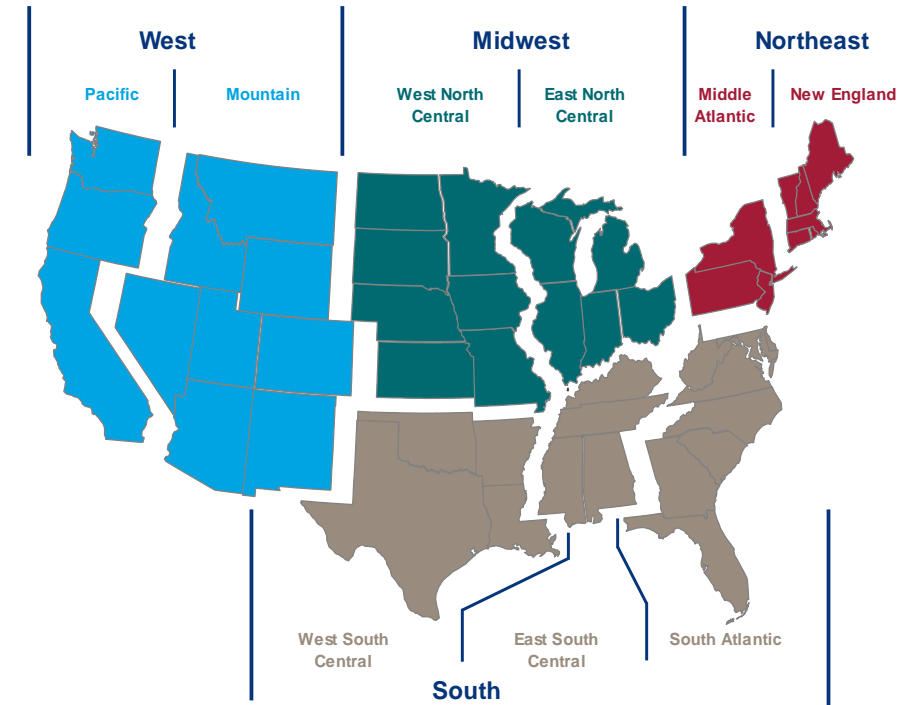

Note: Pacific does not include Alaska or Hawaii



# Power Generation and Transport demand

Transport

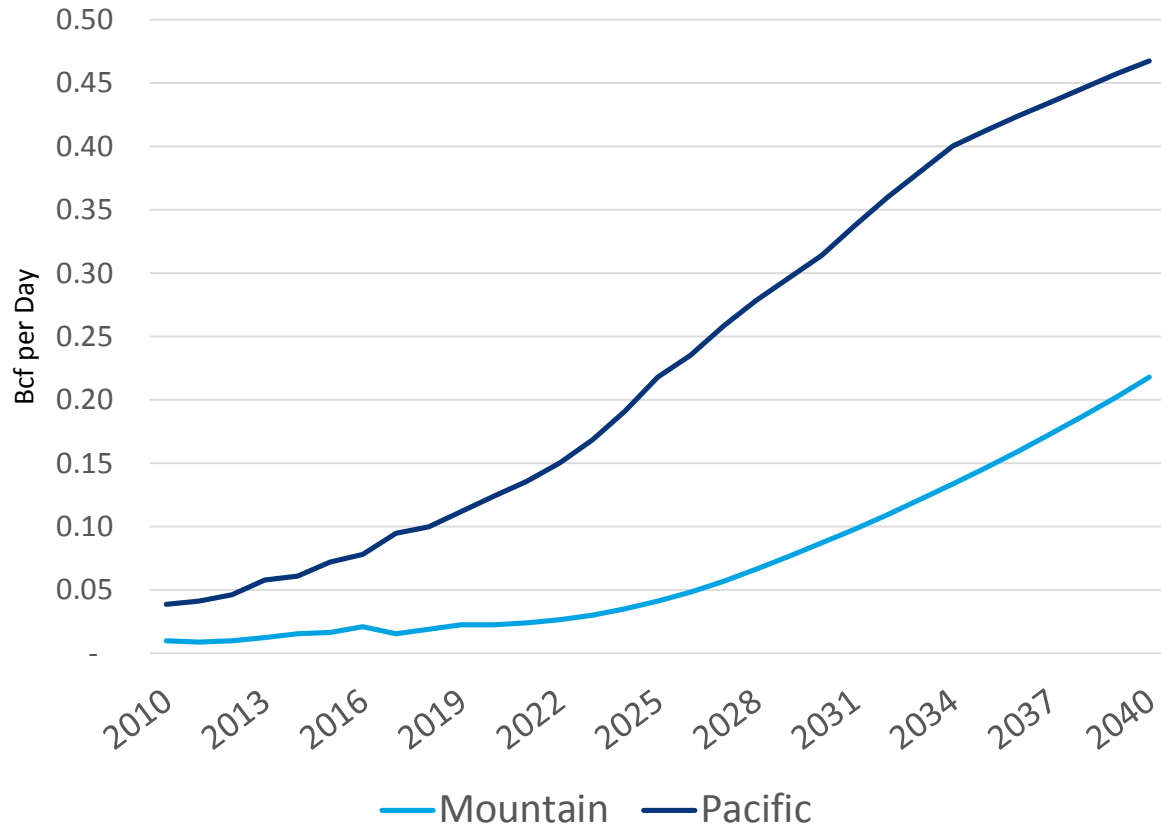

Power Generation

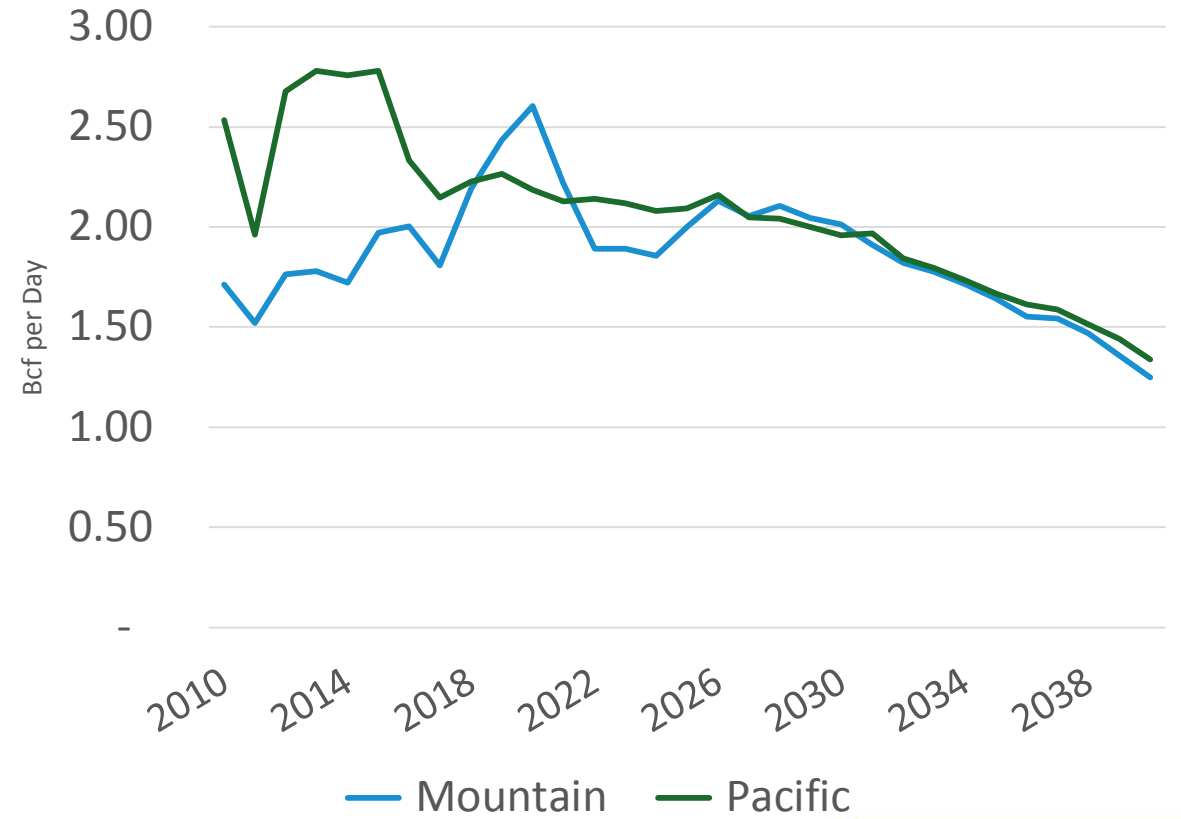

# West demand of Res-Com-Ind

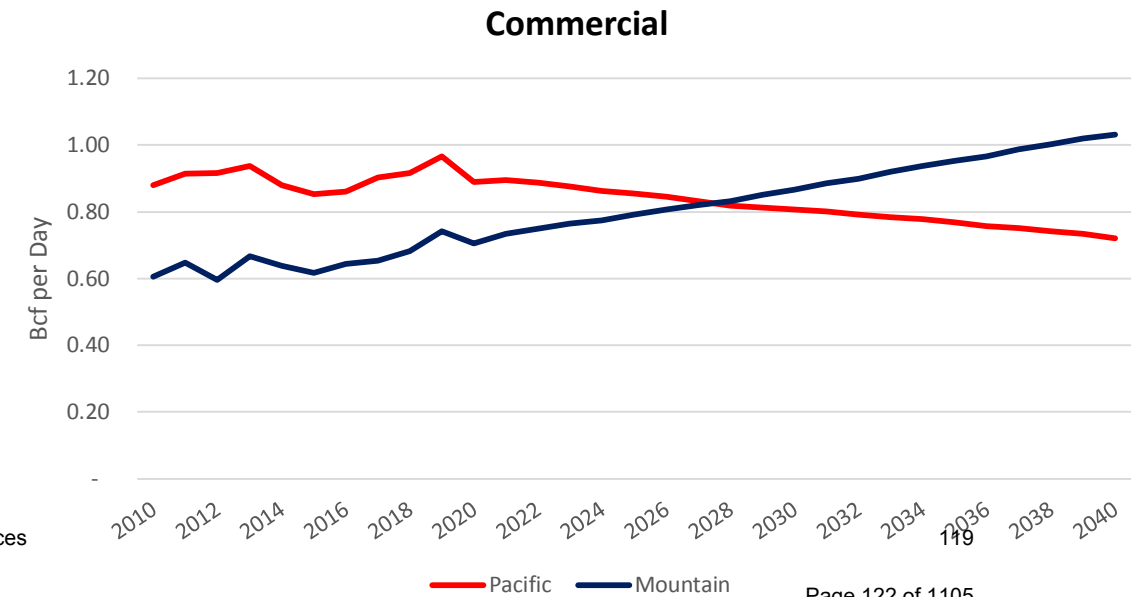
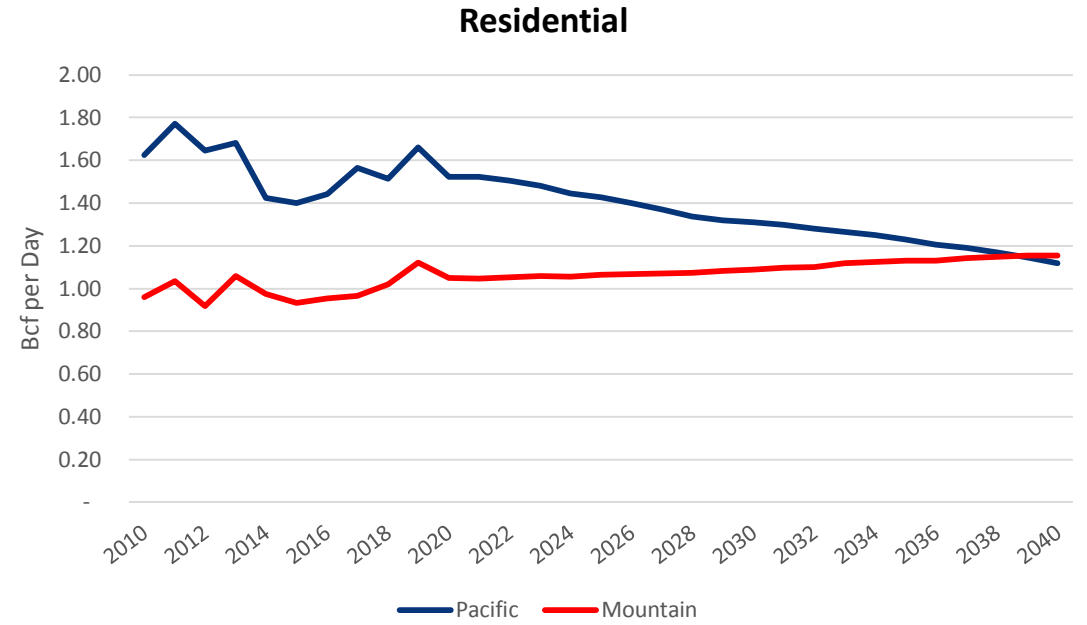
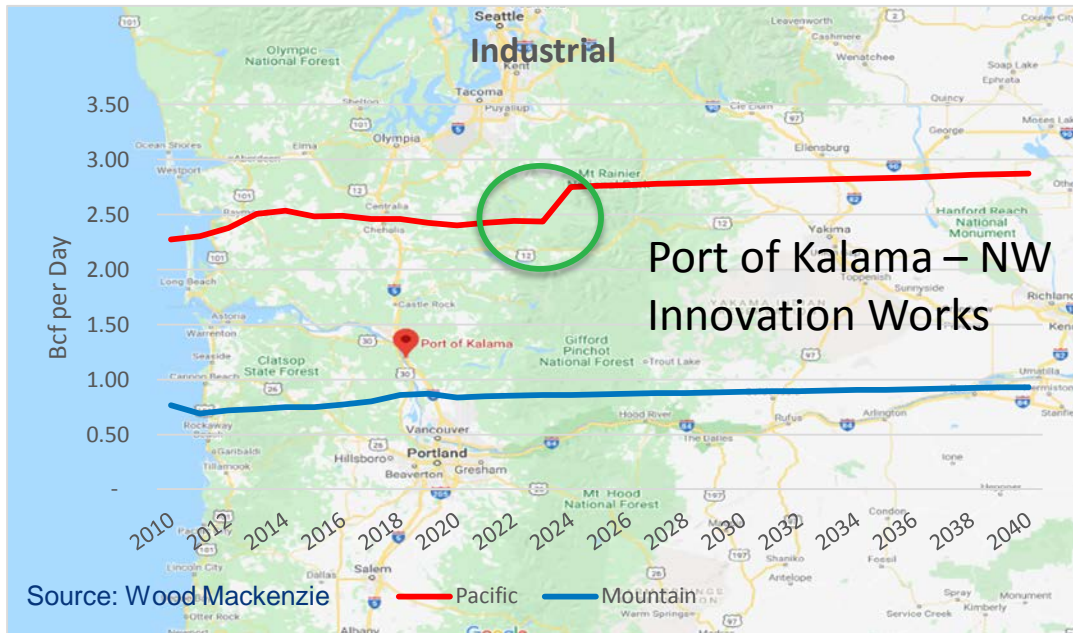

# Wood Mackenzie Disclaimer

- The foregoing [chart/graph/table/information] was obtained from the [North America Gas Service]<sup>TM</sup>, a product of Wood Mackenzie.”
- Any information disclosed pursuant to this agreement shall further include the following disclaimer: "The data and information provided by Wood Mackenzie should not be interpreted as advice and
- you should not rely on it for any purpose. You may not copy or use this data and information except as expressly permitted by Wood Mackenzie in writing. To the fullest extent permitted by law,
- Wood Mackenzie accepts no responsibility for your use of this data and information except as specified in a written agreement you have entered into with Wood Mackenzie for the provision of such of such data and information

# Us Natural Gas Storage

Region	Stocks billion cubic feet (Bcf)				Historical Comparisons			
	07/24/20	07/17/20	net change	implied flow	Year ago (07/24/19)		5-year average (2015-19)	
					Bcf	% change	Bcf	% change
East	706	693	13	13	591	19.5	626	12.8
Midwest	815	799	16	16	669	21.8	687	18.6
Mountain	196	190	6	6	155	26.5	176	11.4
Pacific	313	311	2	2	270	15.9	295	6.1
South Central	1,211	1,221	-10	-10	930	30.2	1,028	17.8
Salt	339	349	-10	-10	227	49.3	274	23.7
Nonsalt	872	872	0	0	703	24.0	754	15.6
<b>Total</b>	<b>3,241</b>	<b>3,215</b>	<b>26</b>	<b>26</b>	<b>2,615</b>	<b>23.9</b>	<b>2,812</b>	<b>15.3</b>

Totals may not equal sum of components because of independent rounding.

Working gas in underground storage compared with the 5-year maximum and minimum

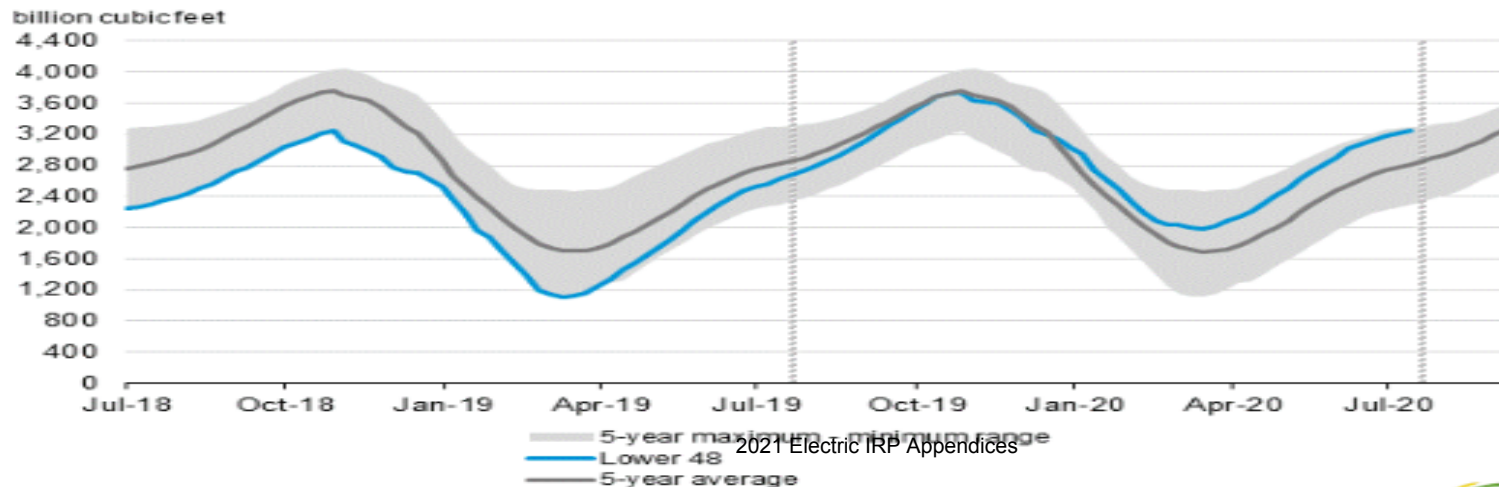

Source: U.S. Energy Information Administration

2021 Electric IRP Appendices



# Rig Counts

Area	Last Count	Count	Change from Prior Count	Date of Prior Count	Change from Last Year	Date of Last Year's Count
U.S.	24 July 2020	251	-2	17 July 2020	-695	26 July 2019
Canada	24 July 2020	42	+10	17 July 2020	-85	26 July 2019
International	June 2020	781	-24	May 2020	-357	June 2019

US Rig Count History

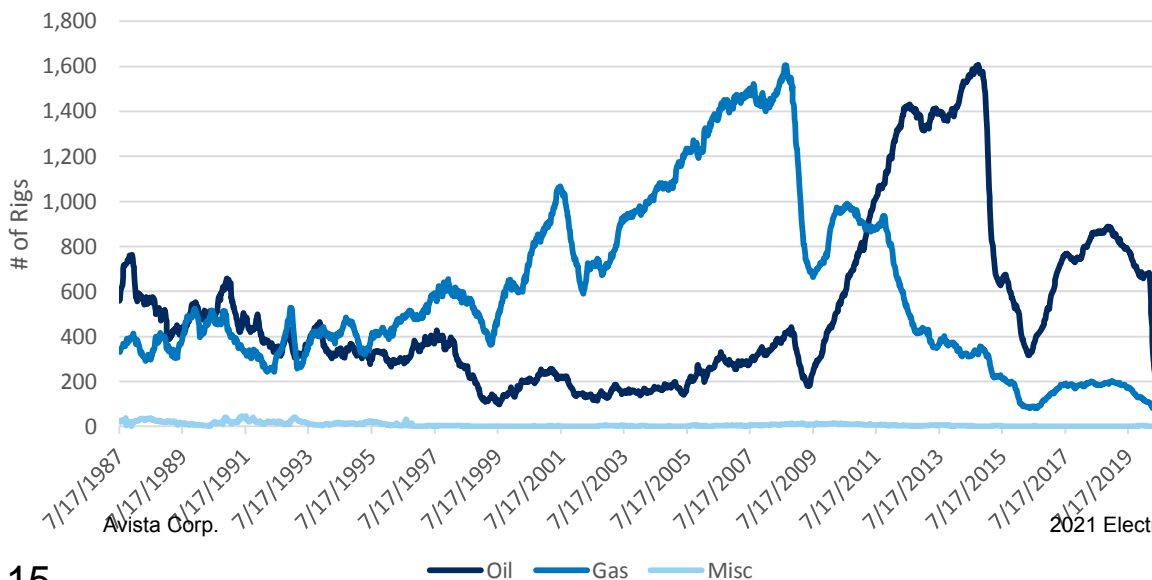

Canadian Rig Count History

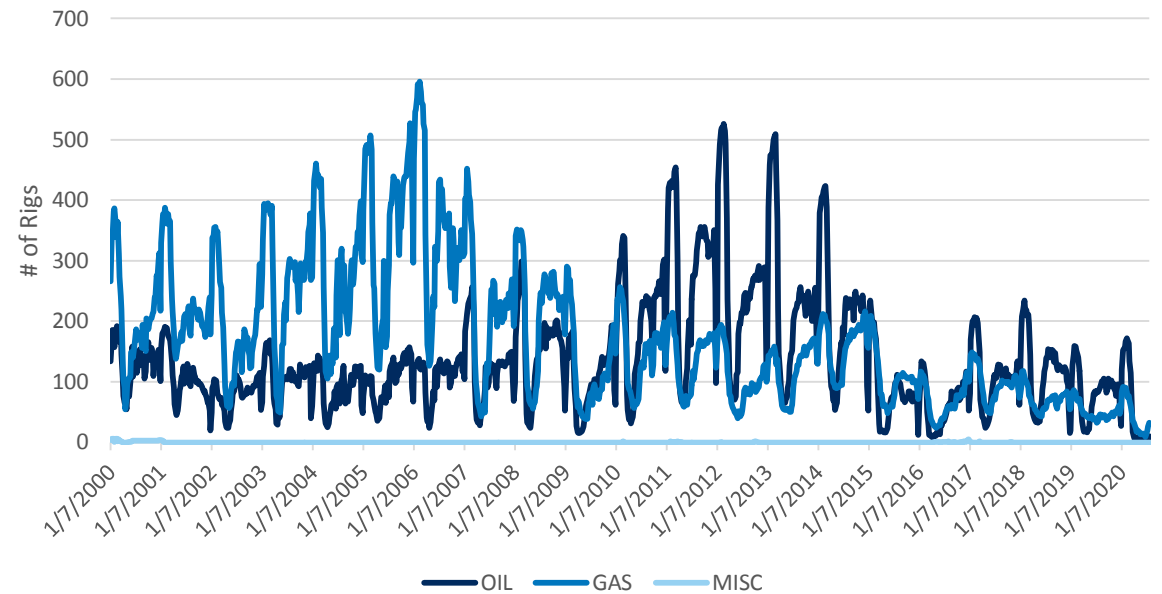

# Production and Drilling efficiency

**Oil production**  
thousand barrels/day

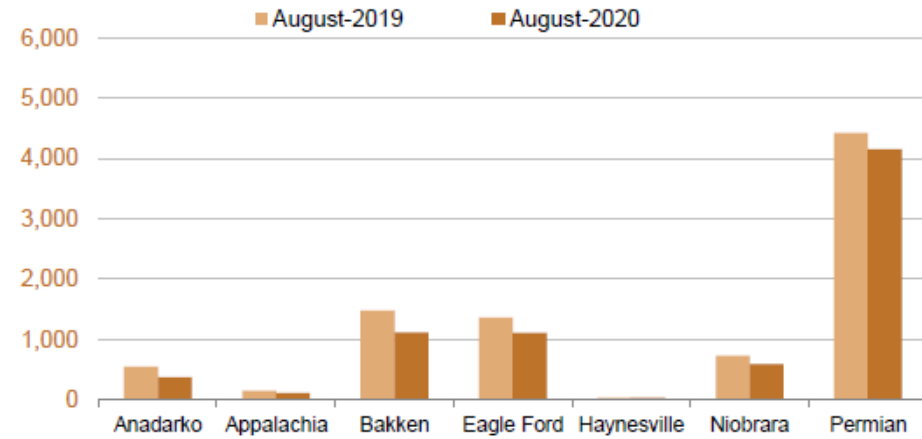

**Natural gas production**  
million cubic feet/day

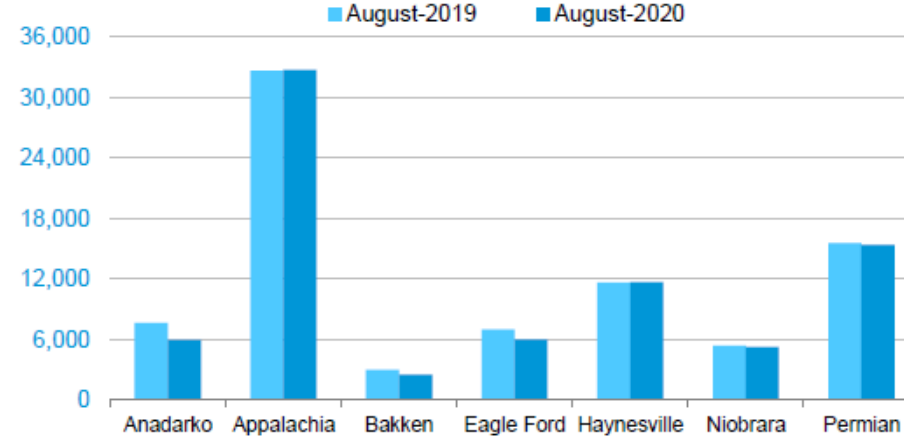

**New-well oil production per rig**  
barrels/day

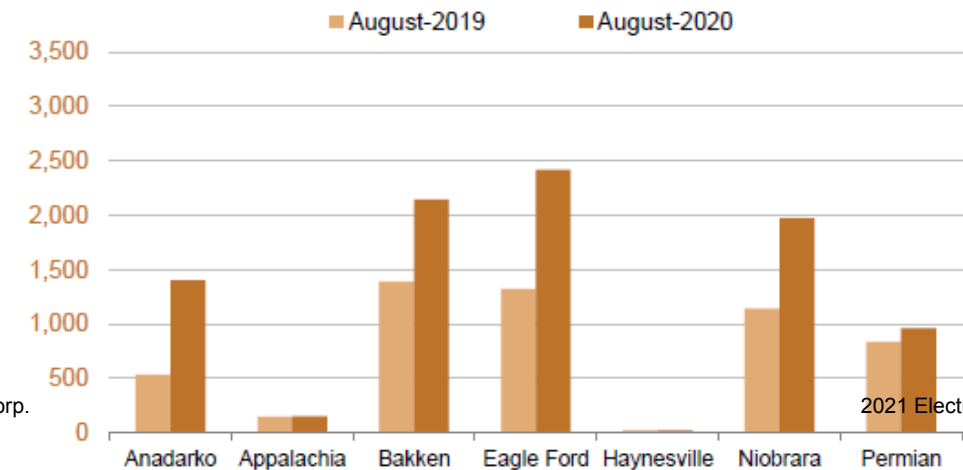

**New-well gas production per rig**  
thousand cubic feet/day

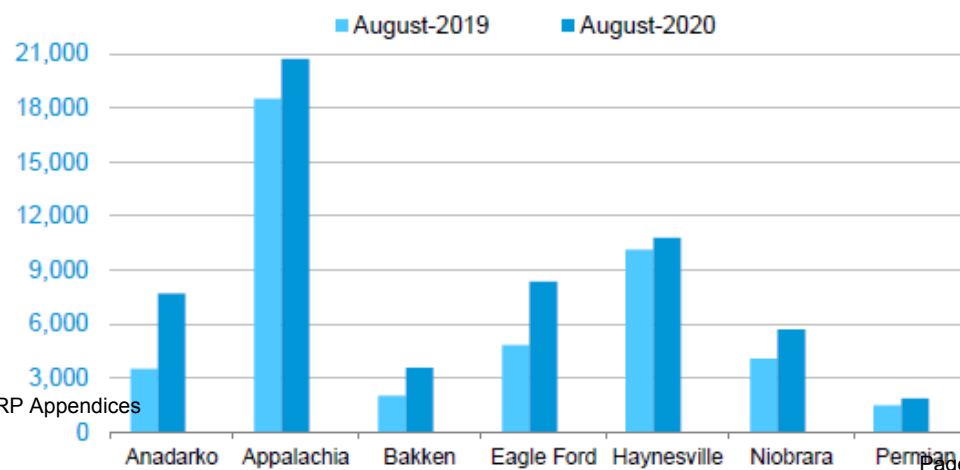

# Historic Cash prices (Jan. 1997 – July 2020)

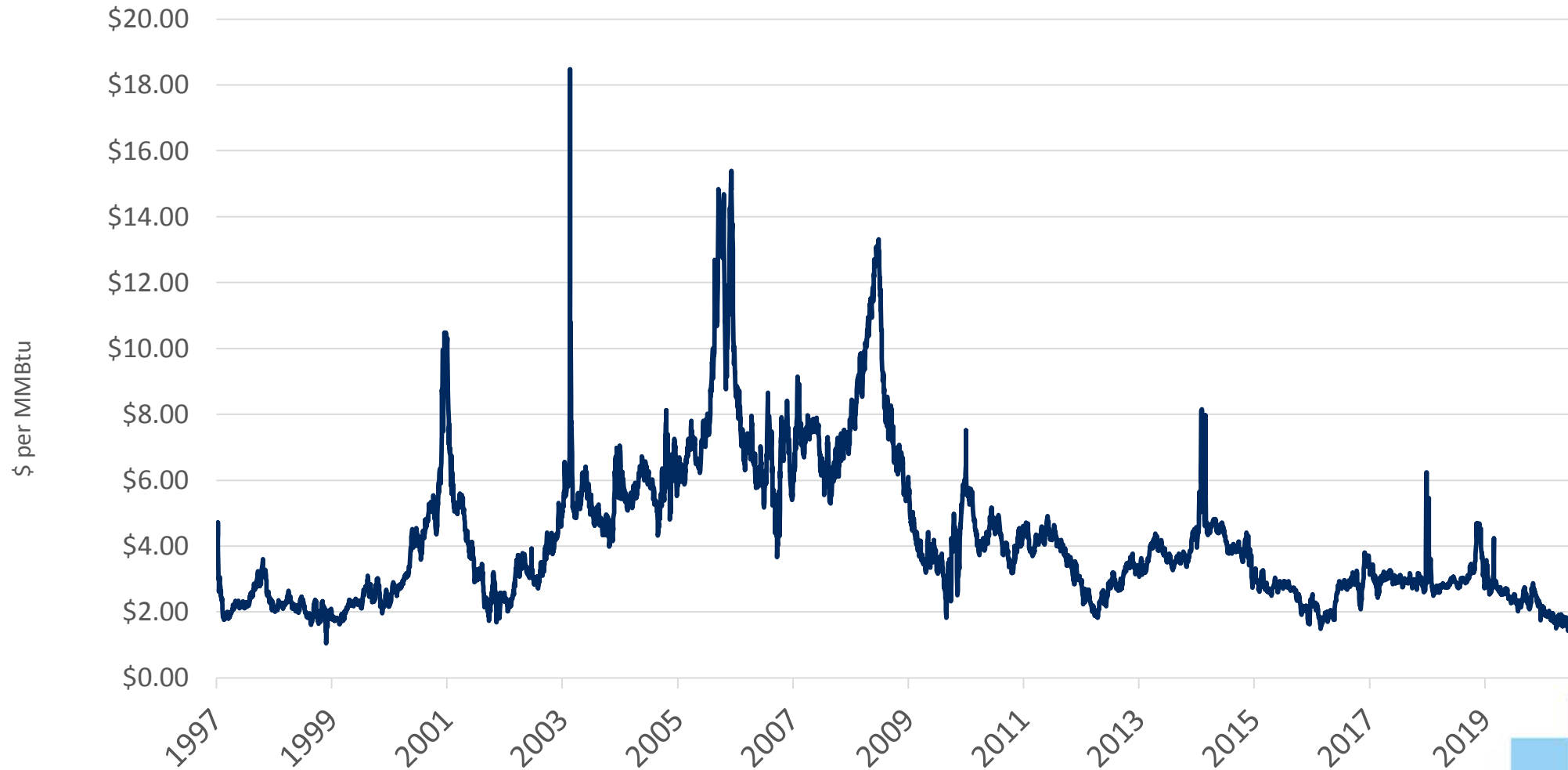



# Upstream Emissions

Tom Pardee



# Upstream Emissions

- Use based greenhouse gas emissions at the point of combustion and include upstream methane emissions
- Link for Natural Gas Advisory Committee information on upstream methane: <https://www.nwcouncil.org/energy/energy-advisory-committees/natural-gas-advisory-committee>

# Global Warming Potential

5th Assessment of the Intergovernmental Panel on Climate Change		
Greenhouse Gas	GWP – 100 Year	GWP – 20 Year
CO <sub>2</sub>	1	1
CH <sub>4</sub>	34	86
N <sub>2</sub> O	298	268

Global warming potential (GWP) factors for conversion  
to CO<sub>2</sub> equivalents (CO<sub>2</sub>e)

Avista Corp.

2021 Electric IRP Appendices

<https://www.c2es.org/content/ipcc-fifth-assessment-report/>

# Upstream Emissions Sources and Estimates

- Rockies emissions – The EPA estimates all leakage through a bottoms up analysis. It will estimate leaks based on equipment operated as designed and combines these values to determine an overall rate of 1%. The emissions and sinks study is published yearly and will capture emissions as they change.
- Canadian emissions (British Columbia and Alberta) – A value of 0.77% was developed from data pertaining to the recent environmental impact studies for the PSE Tacoma LNG plant, Kalama Manufacturing and Export Facility and the 2019 Puget Sound Energy IRP.

# WSU Natural Gas Methane Study

- Sponsored by EDF and utilities to estimate the leakage of distribution systems
- National project and estimated a loss of **0.1 – 0.2** percent of the methane delivered nationwide
- Western region contributes much less as compared to the East
- “Out of **230 measurements, three large leaks accounted for 50%** of the total measured emissions from pipeline leaks. In these types of emission studies, a few leaks accounting for a large fraction of total emissions are not unusual.”

# LDC Upstream Emissions

	Avista Specific Natural Gas	
Combustion	Lbs. GHG/MMBtu	Lbs. CO2e/Mmbtu
CO2	116.88	116.88
CH4	0.0022	0.0748
N2O	0.0022	0.6556
Total Combustion		117.61
Upstream		
CH4	0.313406851	10.66
Total		128.27
Upstream Emissions	Avista's Purchases	Emissions Location
0.77	89.72%	Canada
1.00	10.28%	Rockies
0.79		

\*Avista gas purchases

An average of the total volume purchased over the past 5

years by emissions location

Avista Corp

2021 Electric IRP Appendices

# Electric Upstream Emissions

	Avista Specific Natural Gas	
Combustion	Lbs. GHG/MMBtu	Lbs. CO2e/Mmbtu
CO2	116.88	116.88
CH4	0.0022	0.0748
N2O	0.0022	0.6556
Total Combustion		117.61
Upstream		
CH4	0.304065693	10.34
Total		127.95
Upstream Emissions	Avista's Purchases	Emissions Location
0.77	100.00%	Canada
1.00	0.00%	Rockies
0.77		

\*Avista Purchases

All firm transportation to supply gas is located in Canada



# Renewable Natural Gas (RNG)

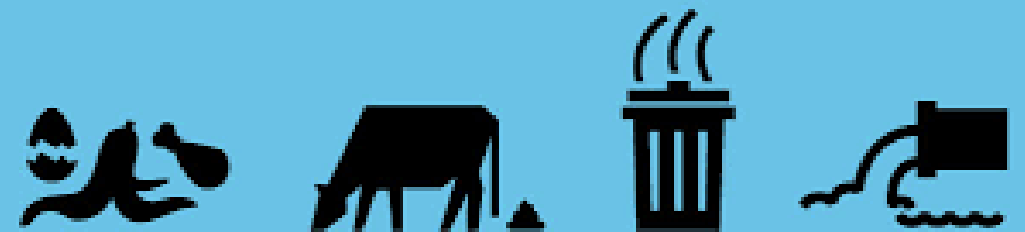

# What is Renewable Natural Gas (RNG)?

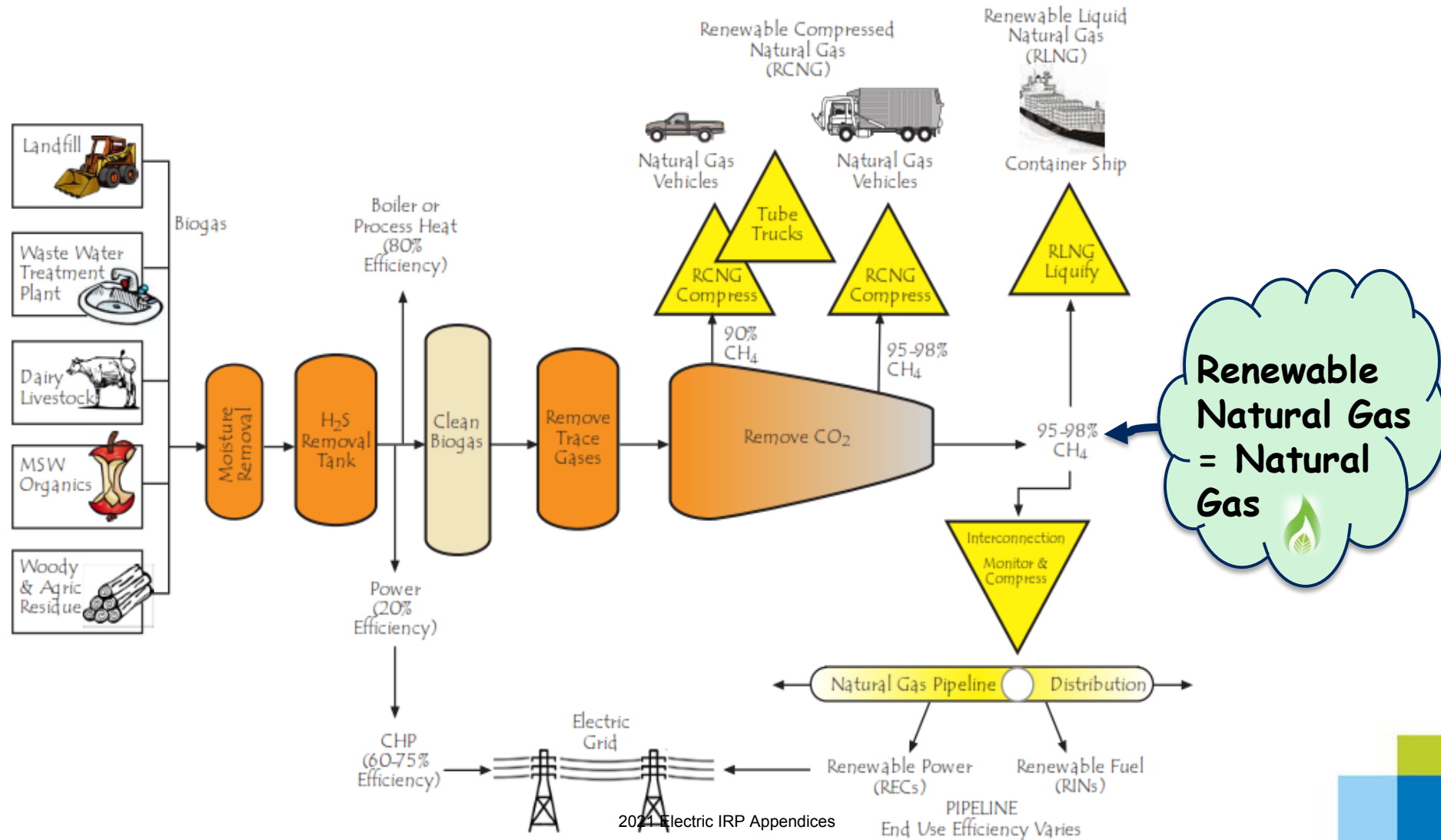



# Why does RNG matter?

## Climate Change Solution

- Natural gas plays critical role for meeting aggressive green house gas (GHG) reductions goals, RNG even more so!
- Utilizes existing infrastructure
- Advantages of RNG
  - “De-carbonizes” gas stream
  - Gives customers another renewable choice

# Carbon Intensity

Fuel Pathway	Carbon Intensity $\frac{gCO_2e}{MJ}$
Diesel*	102.01
Gasoline*	99.78
Fossil CNG <sup>†</sup>	78.37
Landfill CNG <sup>†</sup>	46.42
WWTP CNG*	19.34
MSW CNG*	-22.93
Dairy CNG <sup>‡</sup>	-276.24

\*California Code of Regulation Title 17, §95488, Table 6. Carbon intensity for WWTP is the average of two WWTP pathways.

<sup>†</sup>California Code of Regulation Title 17, §95488, Table 7.

<sup>‡</sup>Method 2B Application CalBio LLC, Dallas Texas, Dairy Digester Biogas to CNG.

# RFS and LCFS Effect on RNG Value

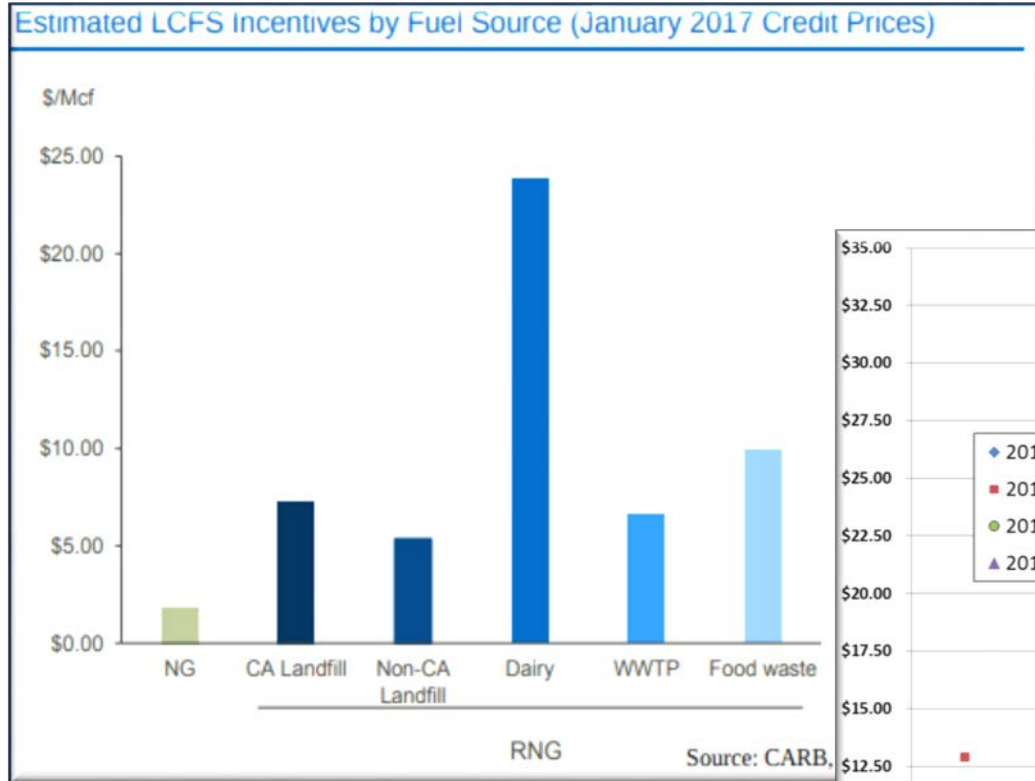

Source: CARB

RIN = renewable identification number

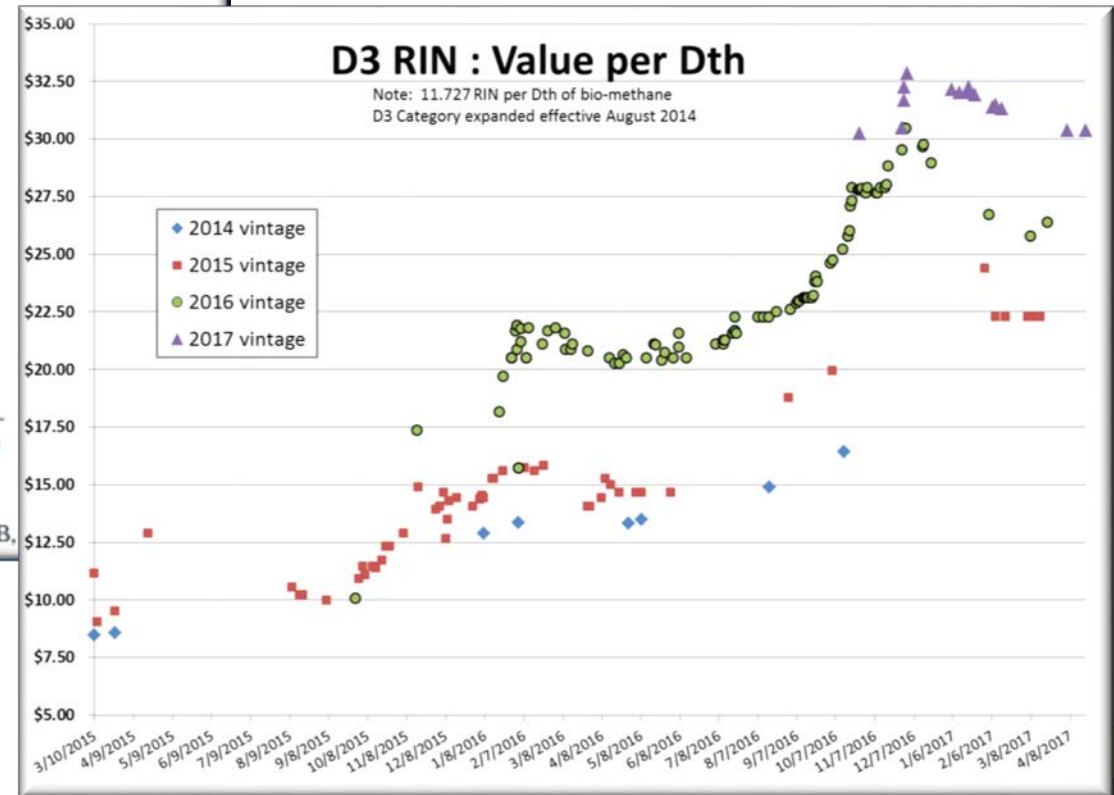

Source: EPA

# What are the challenges & barriers?

- California RNG market (\$30+/Dth v. \$2/Dth)
  - Vehicle emission incentives shut-out other potential end users
  - Producers see the pot of gold in California
- Financing for producers
  - RIN market is volatile
  - No forward pricing for RNG RINs in carbon market
  - Vehicle market may be approaching saturation in CA
  - Producer/LDC partnerships may make sense

# WA RNG Report (HB 2580)

Existing Projects  
Near Term Projects  
Medium Term Projects

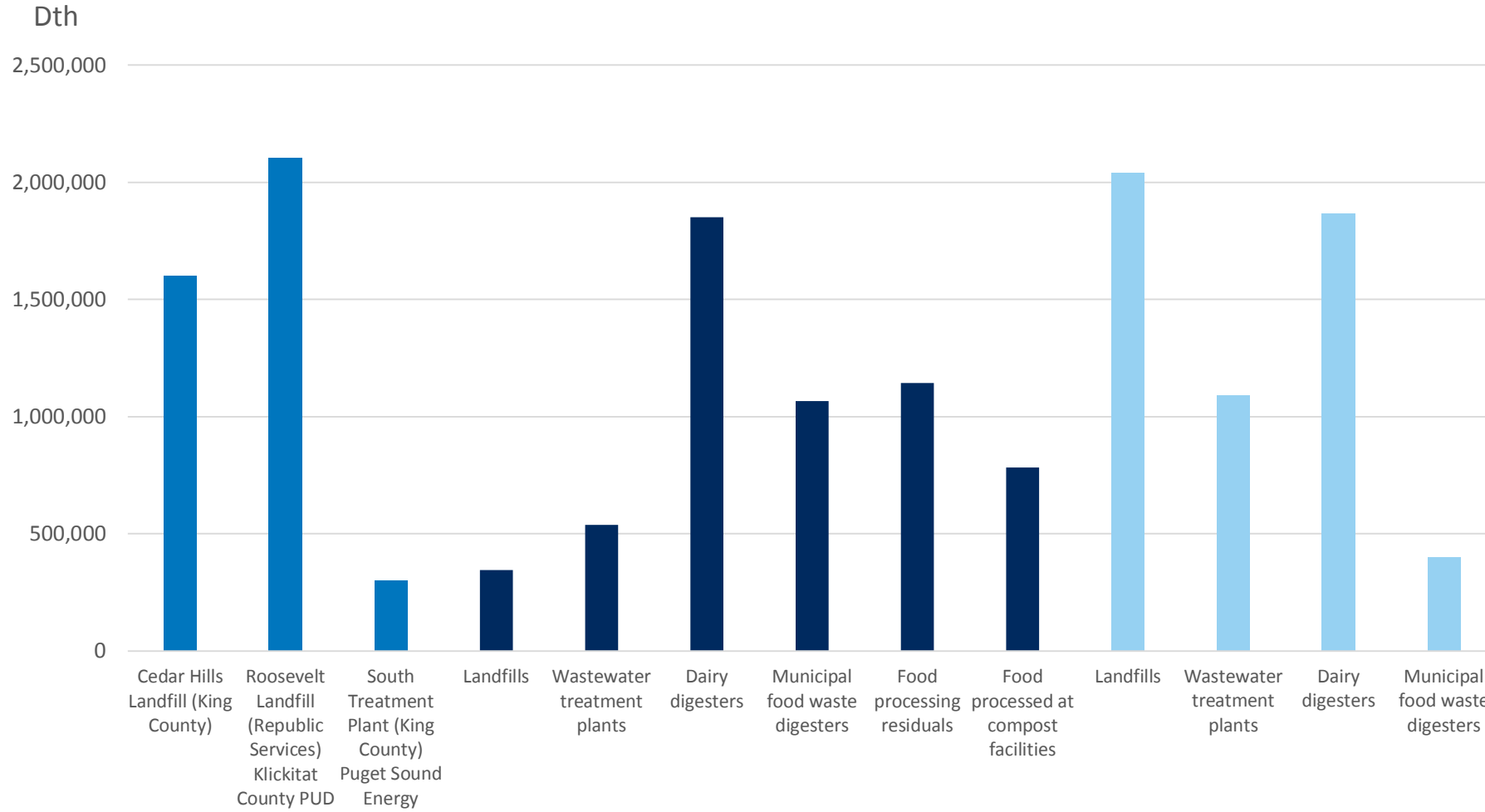

WSU Energy Program, Harnessing Renewable Natural Gas for Low-Carbon Fuel: A Roadmap for Washington State

2021 Electric IRP Appendices

\*Released December 1, 2018

# ID RNG NREL Estimates

Total Potential Annual Production = 32 Bcf

Source - Anaerobic	MMBtu per Year
Landfills	3,712,221
Wastewater Treatment	6,196,531
Agriculture Manure	20,220,571
Source-Separated Organics (Solid Waste)	2,311,354
<b>Total</b>	<b>32,440,676</b>

*National Renewable Energy Laboratory, NREL Biofuels Atlas*

# RNG \$ per Dth/MMBtu

Avista Owned and Operated	ID - WA 2035 Premium Estimate (\$ / Dth)
RNG - Landfills	\$7 - \$10
RNG - Waste Water Treatment Plants (WWTP)	\$12 - \$22
RNG - Agriculture Manure	\$28 - \$53
RNG - Food Waste	\$29 - \$53

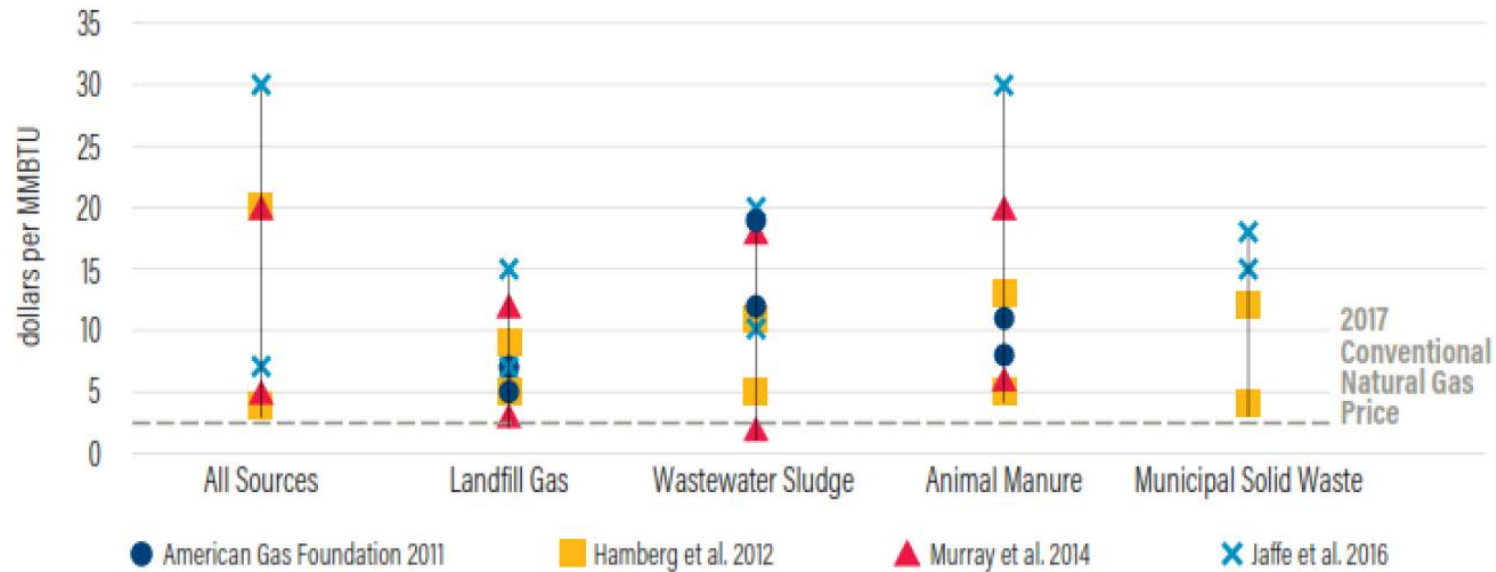

Source: Promoting RNG in WA State

# Natural Gas IRP

A detailed level of RNG understanding and evaluation process will be included in the Natural Gas IRP TAC #3 meeting on September 30, 2020





# Natural Gas Price Forecast

Michael Brutocao, Natural Gas Analyst  
Second Technical Advisory Committee Meeting  
August 6, 2020

# Henry Hub Expected Price Methodology

- Expected Henry Hub prices derived from a blend of forward market prices on the NYMEX (as of 6/30/2020) and forecasted prices from the 2020 Annual Energy Outlook (EIA) and two consultants

	2020 – 2022	2023	2024	2025	2026 – 2045
NYMEX	100%	75%	50%	25%	-
EIA/AEO	-	8.33%	16.66%	25%	33.33%
Consultant 1	-	8.33%	16.66%	25%	33.33%
Consultant 2	-	8.33%	16.66%	25%	33.33%

# Henry Hub Expected Price and Forecast Blending

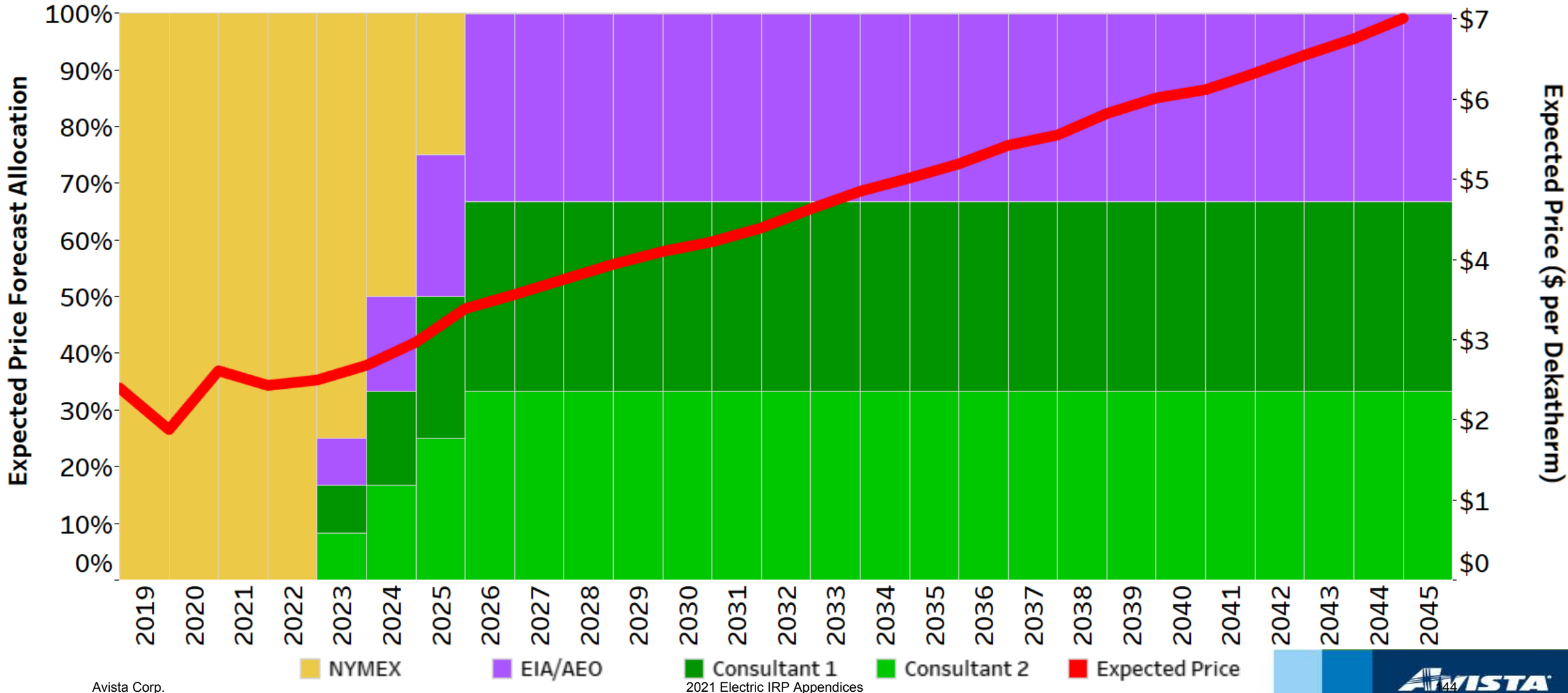

Expected Price (\$ per Dekatherm)

# Henry Hub Expected Price and Average Annual Forecasts

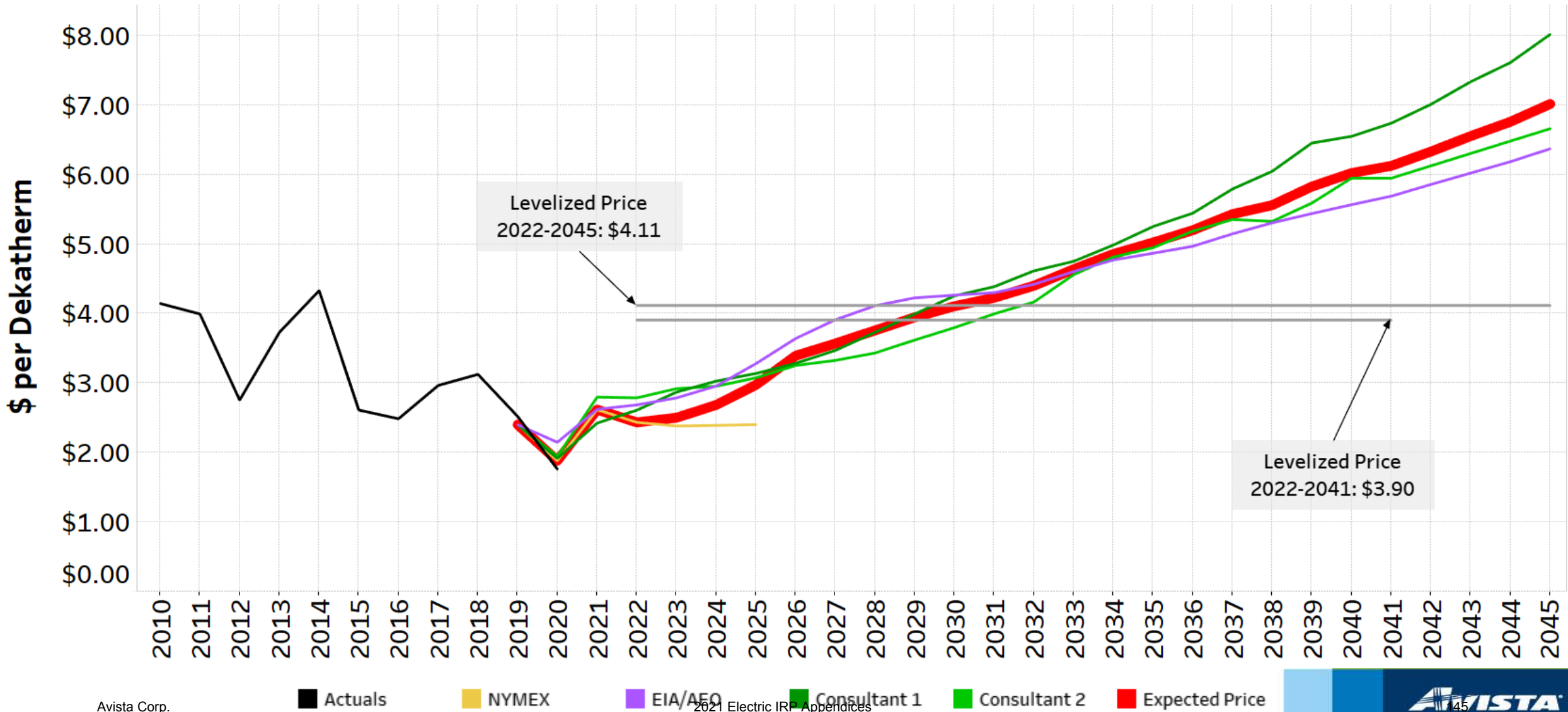

# Stochastic Price Forecasting Methodology

- Evaluate a set of potential future outcomes based on the probability of occurrence
  - Expected Price used as the input
  - At each period, random price adjustments follow a lognormal distribution based on the Expected Price
    - It is common practice to use lognormal distributions in forecasting prices as they have no upward bound and should not fall below zero
- A single “draw” contains a set of unique price movements
- 500 (electric) and 1000 (gas) draws were evaluated

# Sample Stochastic Price Draws

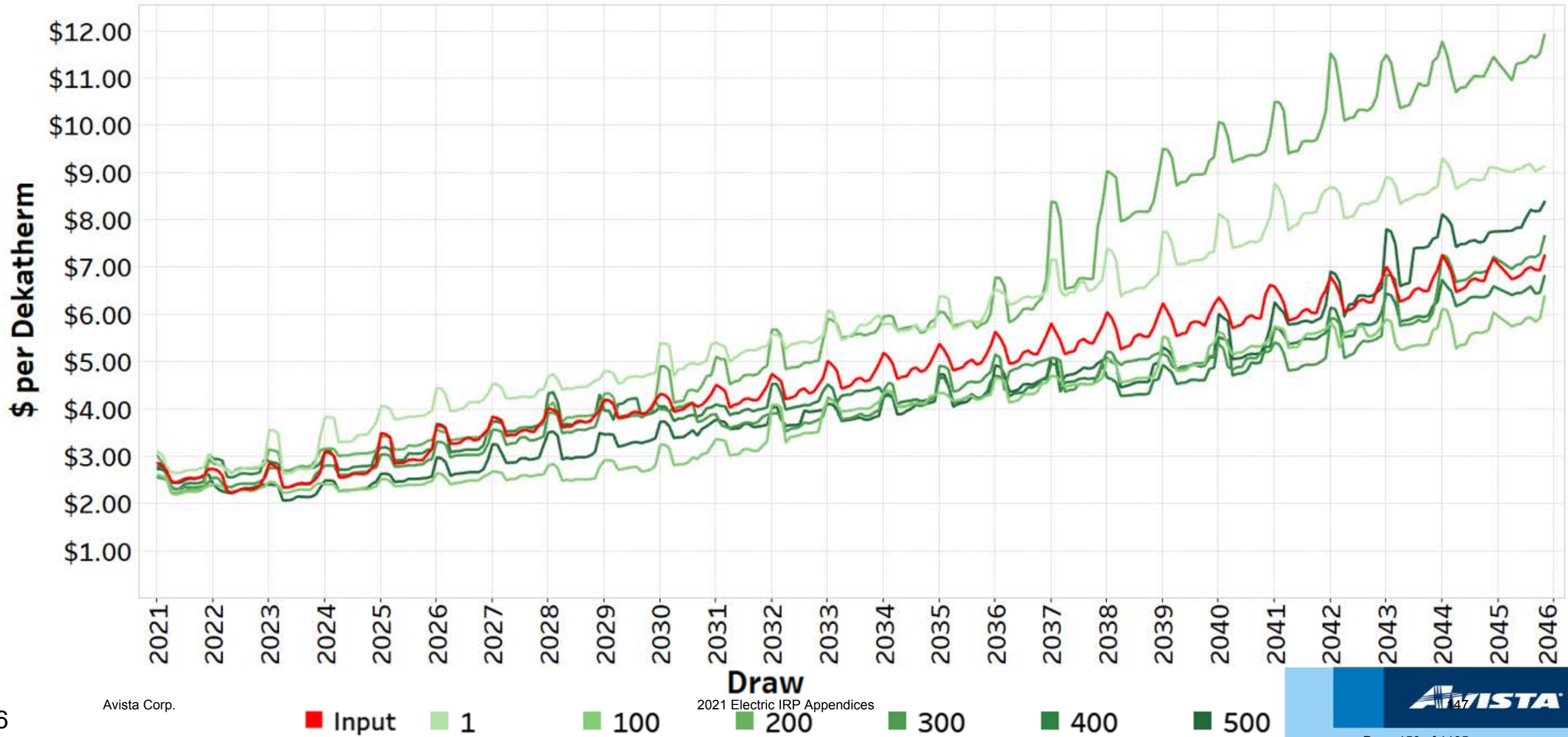

Draw  
2021 Electric IRP Appendices

Input 1 100 200 300 400 500

# Stochastic Price Draws

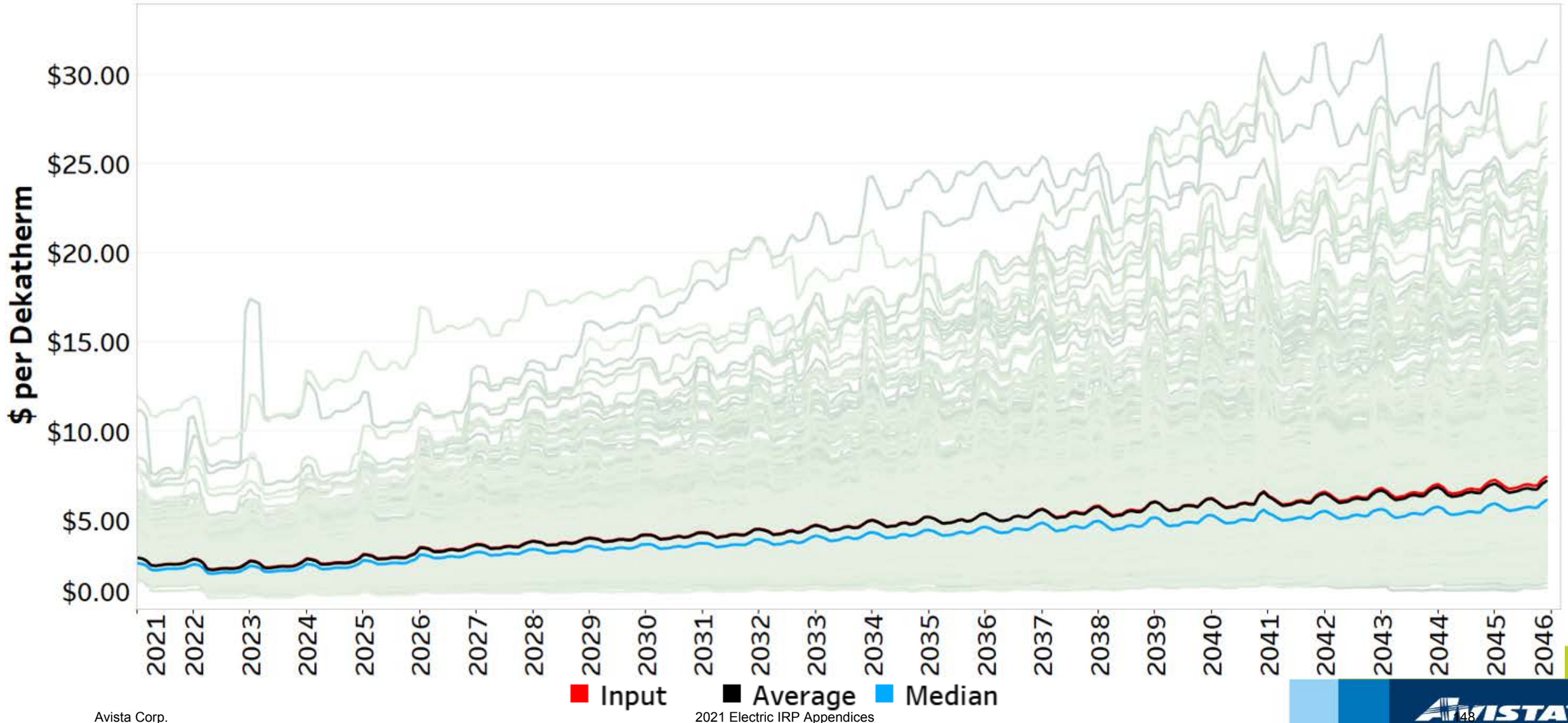

# Stochastic Prices (Results from 500 Draws)

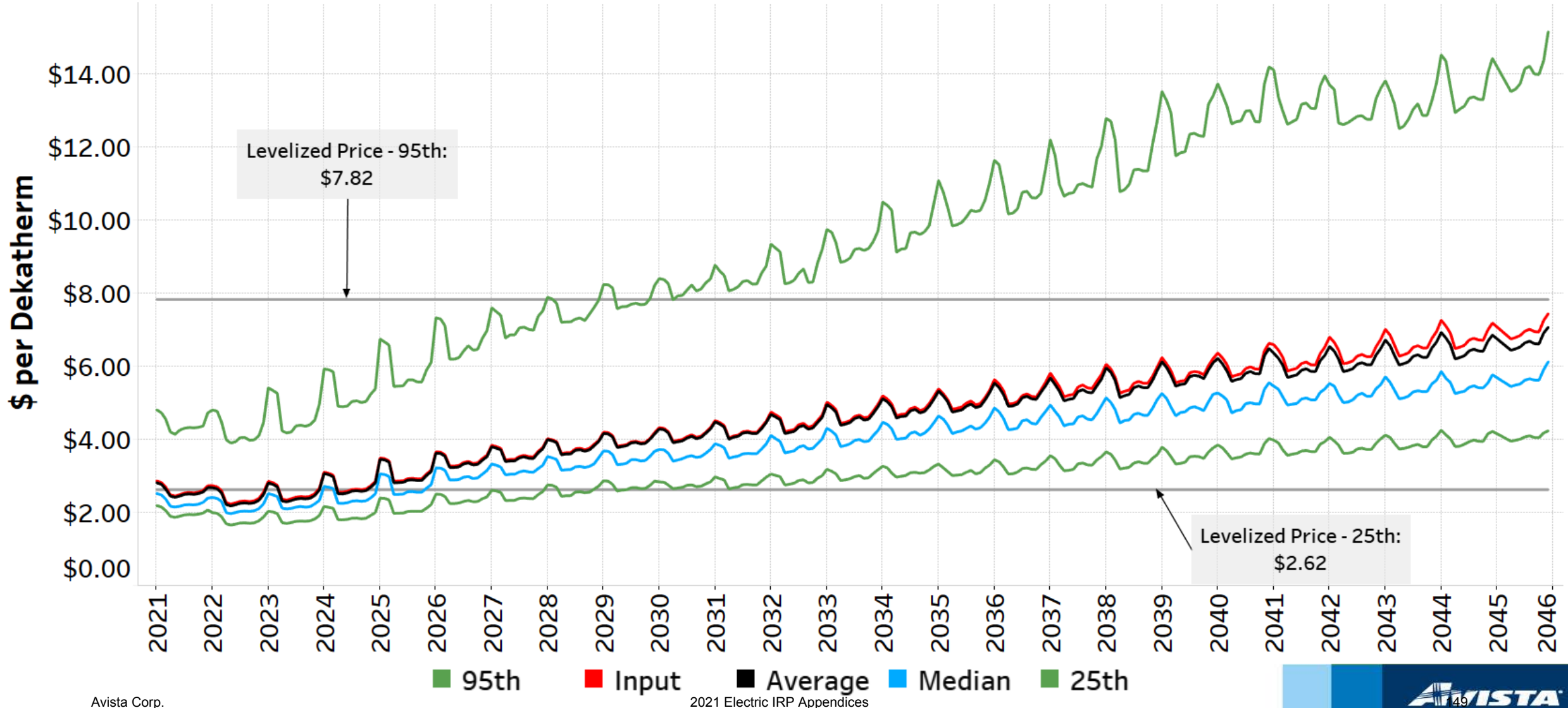



# Levelized Stochastic Prices (Results from 500 Draws)

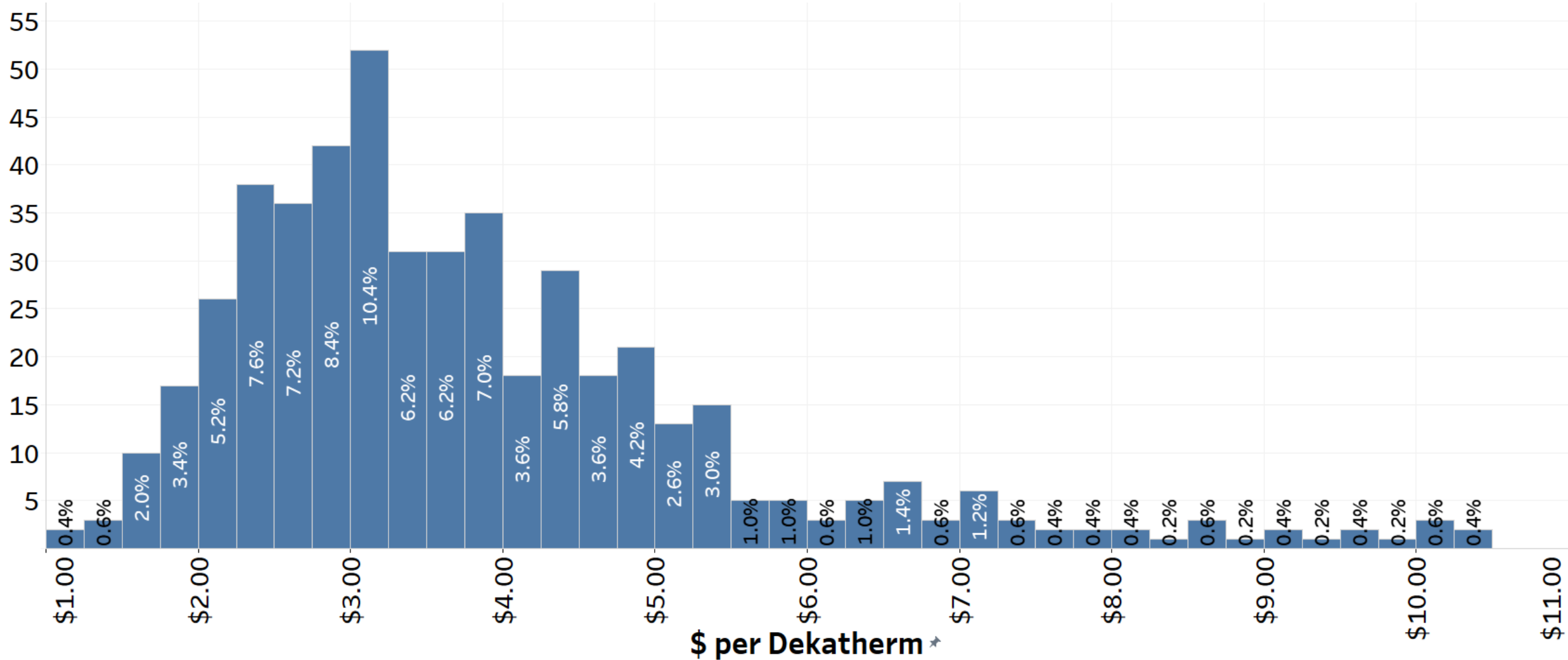

# Stochastic Prices (Results from 1000 Draws)

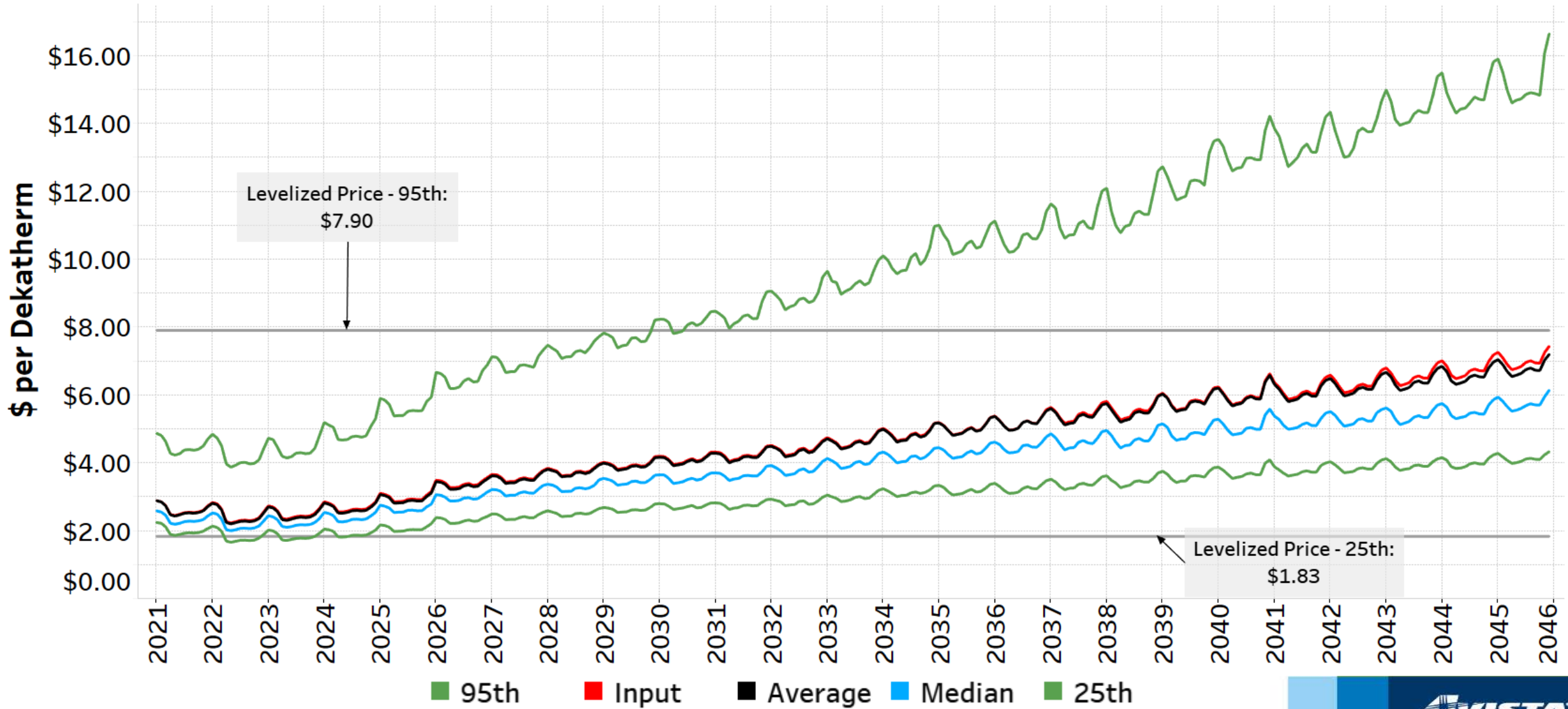

Levelized Price - 25th:  
\$1.83

Levelized Price - 95th:  
\$7.90

■ 95th ■ Input ■ Average ■ Median ■ 25th

2021 Electric IRP Appendices

# Levelized Stochastic Prices (Results from 1000 Draws)

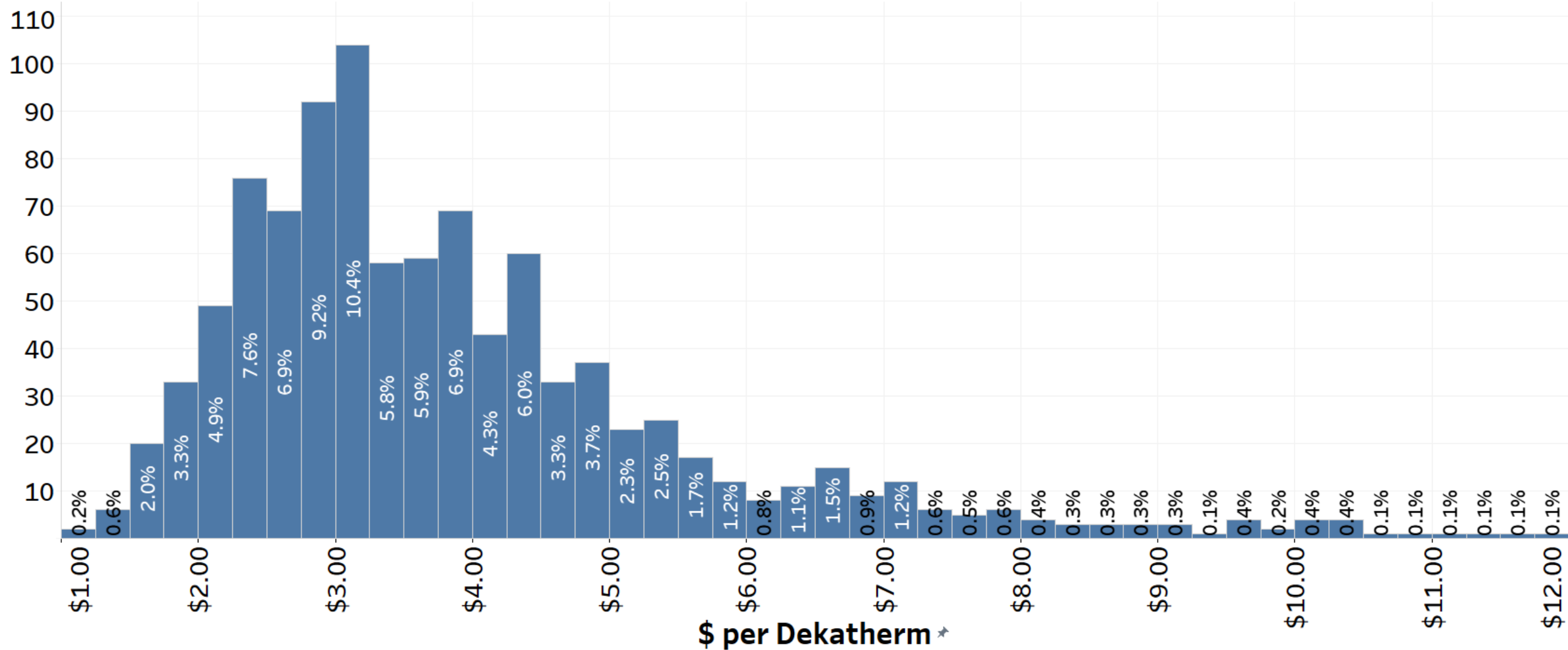

# Prices by Gas Hub (Henry Hub Expected Price + Basis)

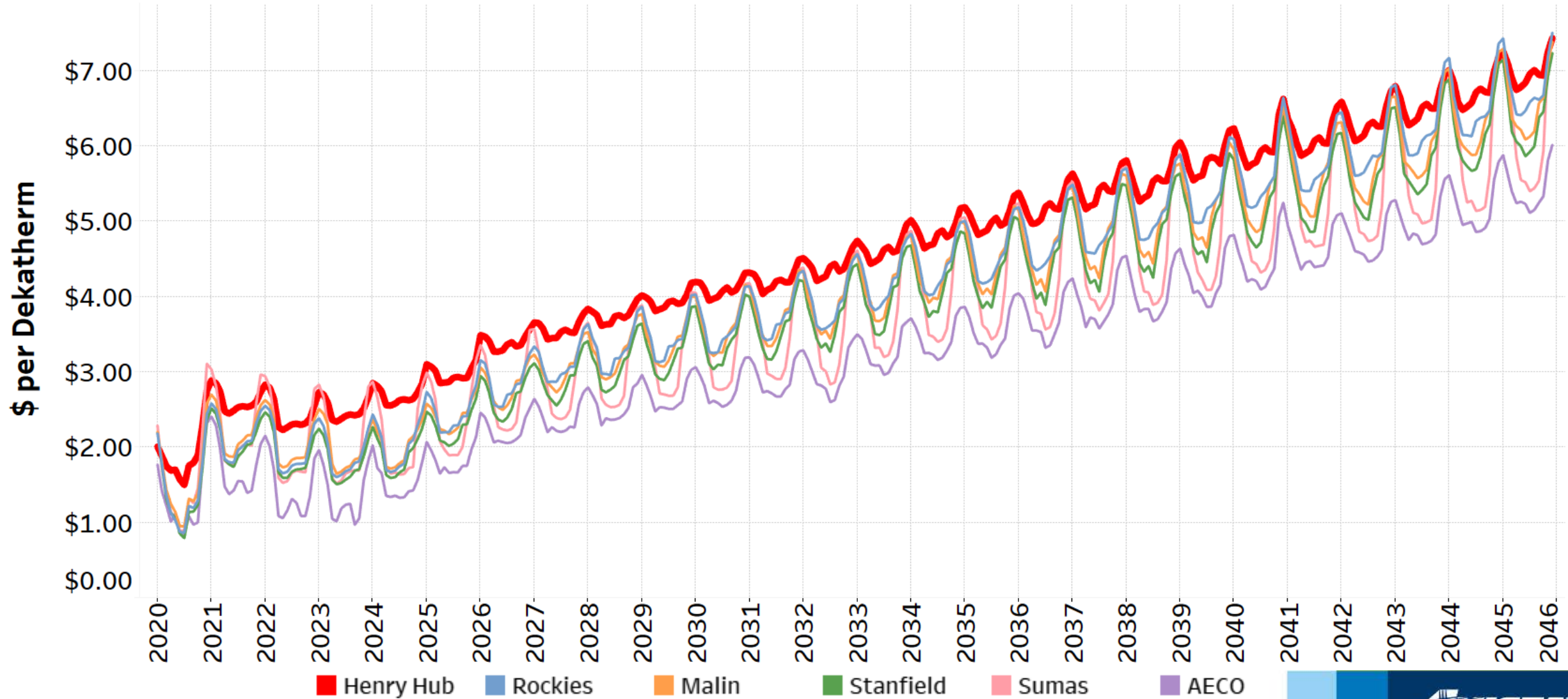

Henry Hub Rockies Malin Stanfield Sumas AECO

# Levelized Prices 2022-2041

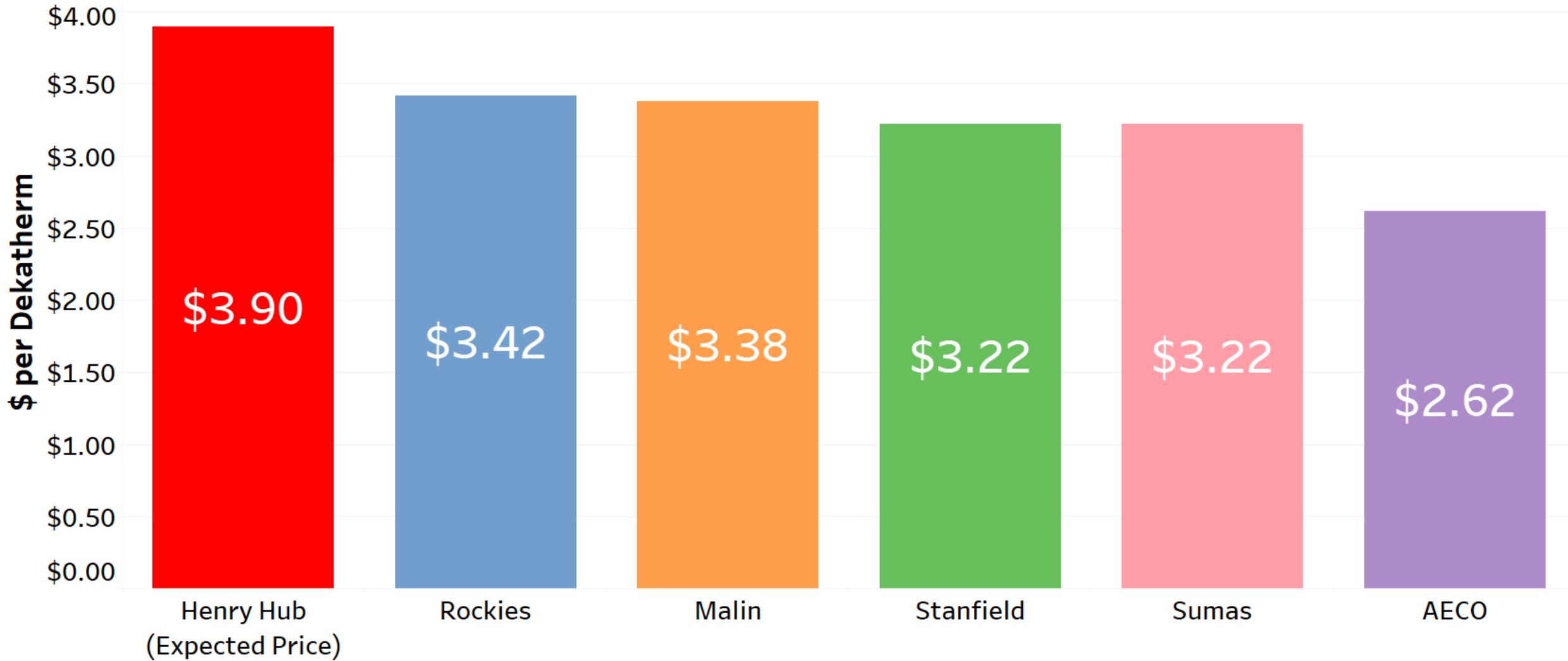

# Levelized Prices 2022-2045





# 2021 Electric IRP Regional Energy Policy Update

John Lyons, Ph.D.  
Second Technical Advisory Committee Meeting  
August 6, 2020

# Production and Investment Tax Credits

- Production tax credit \$15/MWh adjusted for inflation (\$25/MWh for 2019) for 10 years for wind construction started by 12/31/20
- Investment tax credit for new solar construction drops from 30% in 2019
  - 26% in 2020
  - 22% in 2021
  - 10% from 2022 onward
- Will be watching for any possible extensions with all of the COVID-19 proposals



# State and Provincial Policies

State/Province	No Coal	RPS	Clean Energy/Carbon Goal
Alberta	Yes	Yes	Yes
Arizona	No	Yes	No
British Columbia	Yes	Yes	Yes
California	Yes	Yes	Yes
Colorado	No	Yes	Yes
Idaho	No	No	No
Montana	No	Yes	No
Nevada	No	Yes	Goal
New Mexico	No	Yes	No
Oregon	Yes	Yes	Yes
Utah	No	Goal	No
Washington	Yes	Yes	Yes
Wyoming	No	No	No

# Washington

- Clean Energy Transformation Act (CETA) SB 5116:
  - No coal serving Washington customers by end of 2025
  - Greenhouse gas neutral by 2030, up to 20% alternative compliance
  - 2% cost cap over four-year compliance period
  - 100% non-emitting by January 1, 2045
  - Social cost of carbon for new resources
  - Additional reporting and planning requirements
  - Highly impacted and vulnerable community identification and resource planning implications
  - Ongoing rulemaking in various stages for planning and reporting

# Washington

- **HB 1257: Clean Buildings for Washington Act**
  - Develop energy performance standards for commercial buildings over 50,000 square feet (2020 – 2028) “... to maximize reductions of greenhouse gas emissions from the building sector”
  - By 2022, natural gas utilities must identify and acquire all available cost-effective conservation including a social cost of carbon at the 2.5% discount rate.(Section 11 and 15)
  - Natural gas utilities may propose renewable natural gas (RNG) programs for their customers and offer a voluntary RNG tariff
  - Building code updates to improve efficiency and develop electric vehicle charging infrastructure

# Oregon

## Executive Order 20-04

- New GHG reduction goal
  - 45% below 1990 levels by 2035
  - 80% below 1990 levels by 2050
- Directs 16 Oregon agencies to “exercise any and all authority and discretion” to reach GHG reduction goals and “prioritize and expedite” action on GHG reductions “to the full extent allowed by law.”
- Agencies are working on rulemaking and implementation

## SB 98

- Development of utility renewable natural gas programs



# 2021 Electric and Natural Gas IRPs Natural Gas & Electric Coordinated Scenario

James Gall/Tom Pardee  
Second Technical Advisory Committee Meeting  
August 6, 2020

# Scenario Goal

- Understand impact to electric resource planning if customers switch from natural gas to electric service
- Scenario Proposal:
  - By 2030: 50% of Washington Residential & Commercial customers
  - By 2045: 80% of Washington Residential & Commercial customers
- Potential Scenarios:
  - Hybrid natural gas/electric heat pumps
  - Highly efficient technology allows for cold temperature space heating

# Converting Natural Gas Load to Electric Load

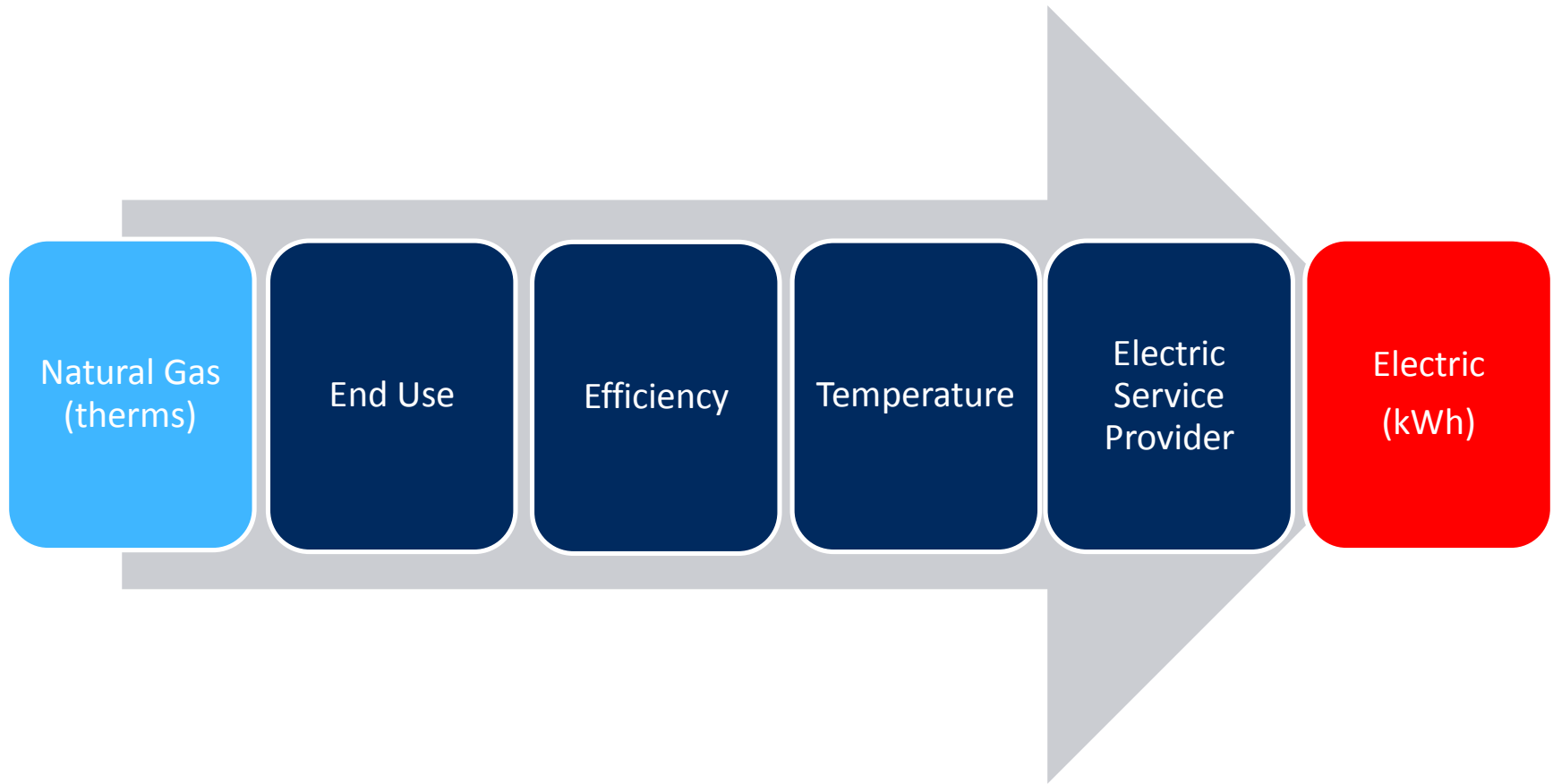

# WA Res/Com Natural Gas Load Forecast

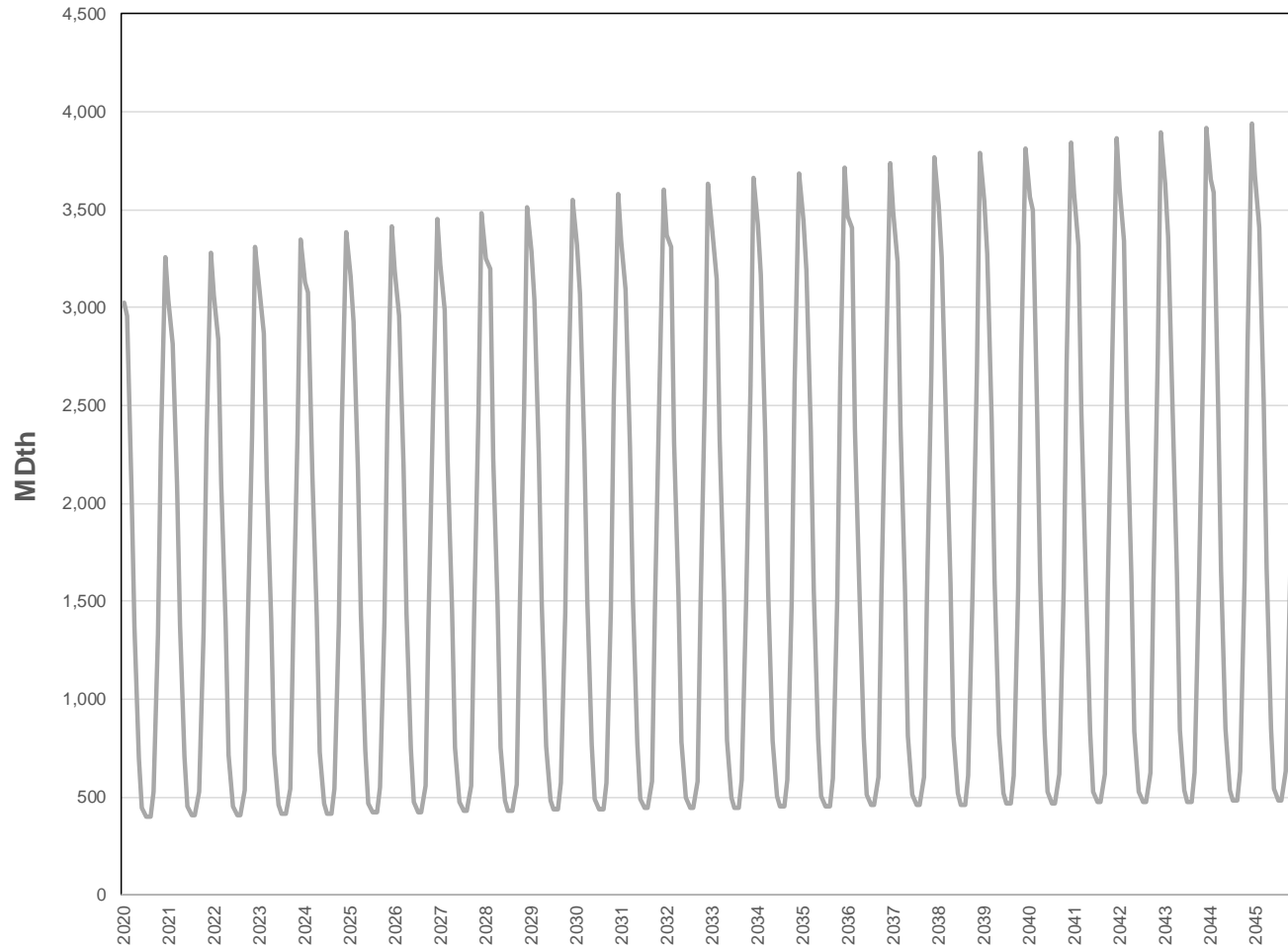



# Customer Penetration Forecast

% Natural Gas Customer Reduction (WA Only)

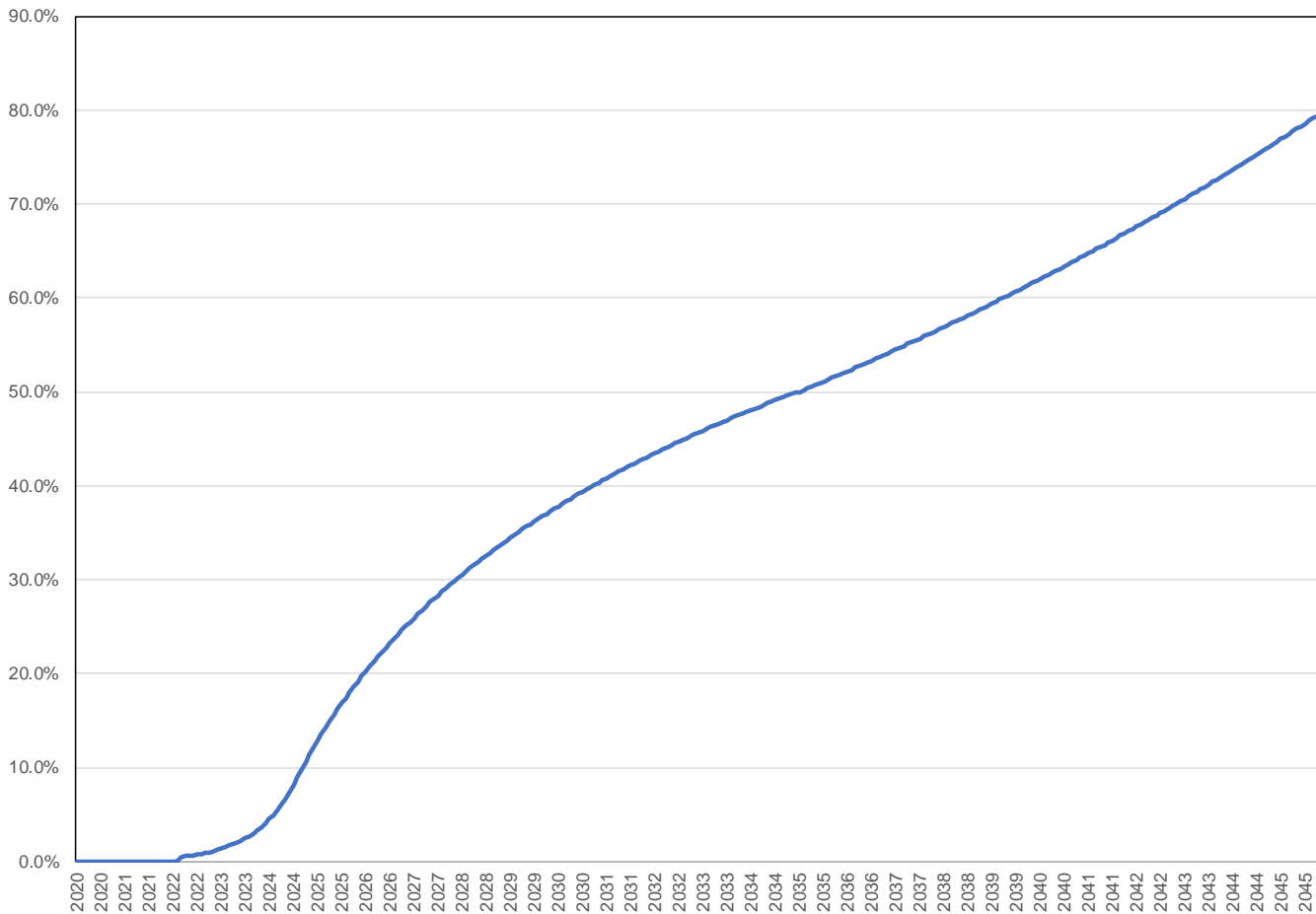

# End Use Efficiency

End Use @ 5 Degrees

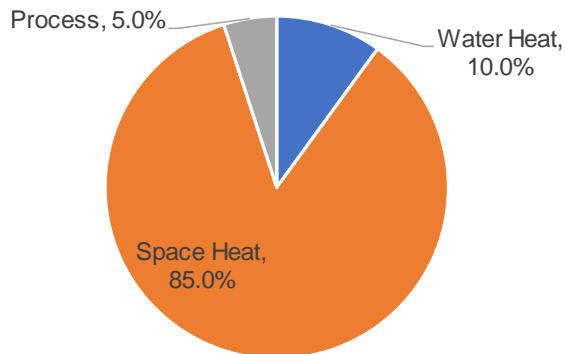

Efficiency @ 5 Degrees

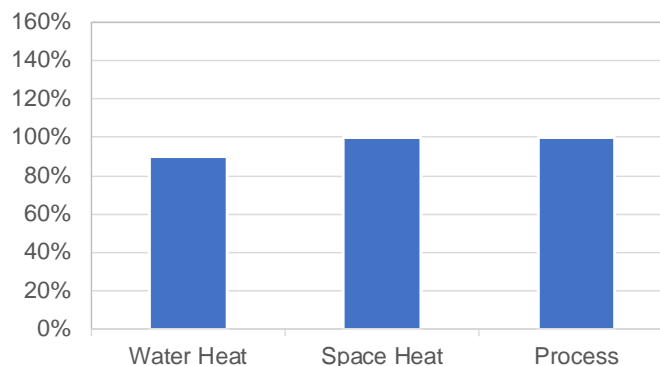

End Use @ 35 Degrees

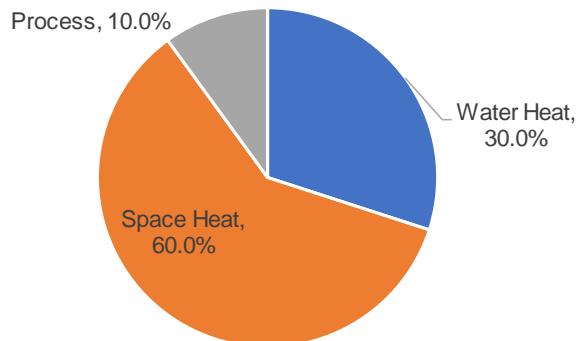

Efficiency @ 35 Degrees

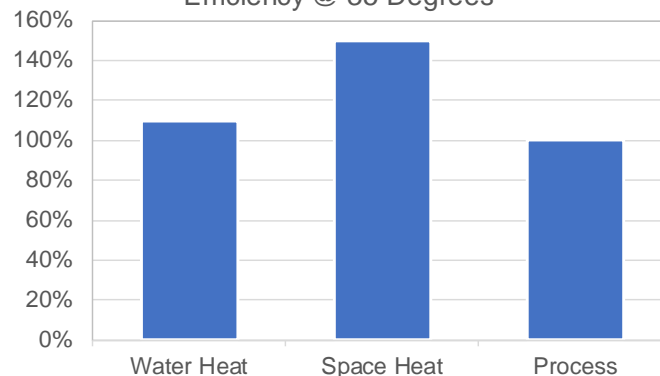

*Note: All efficiency conversion use a 10% efficiency benefit to electric*

# Energy Conversion Factor

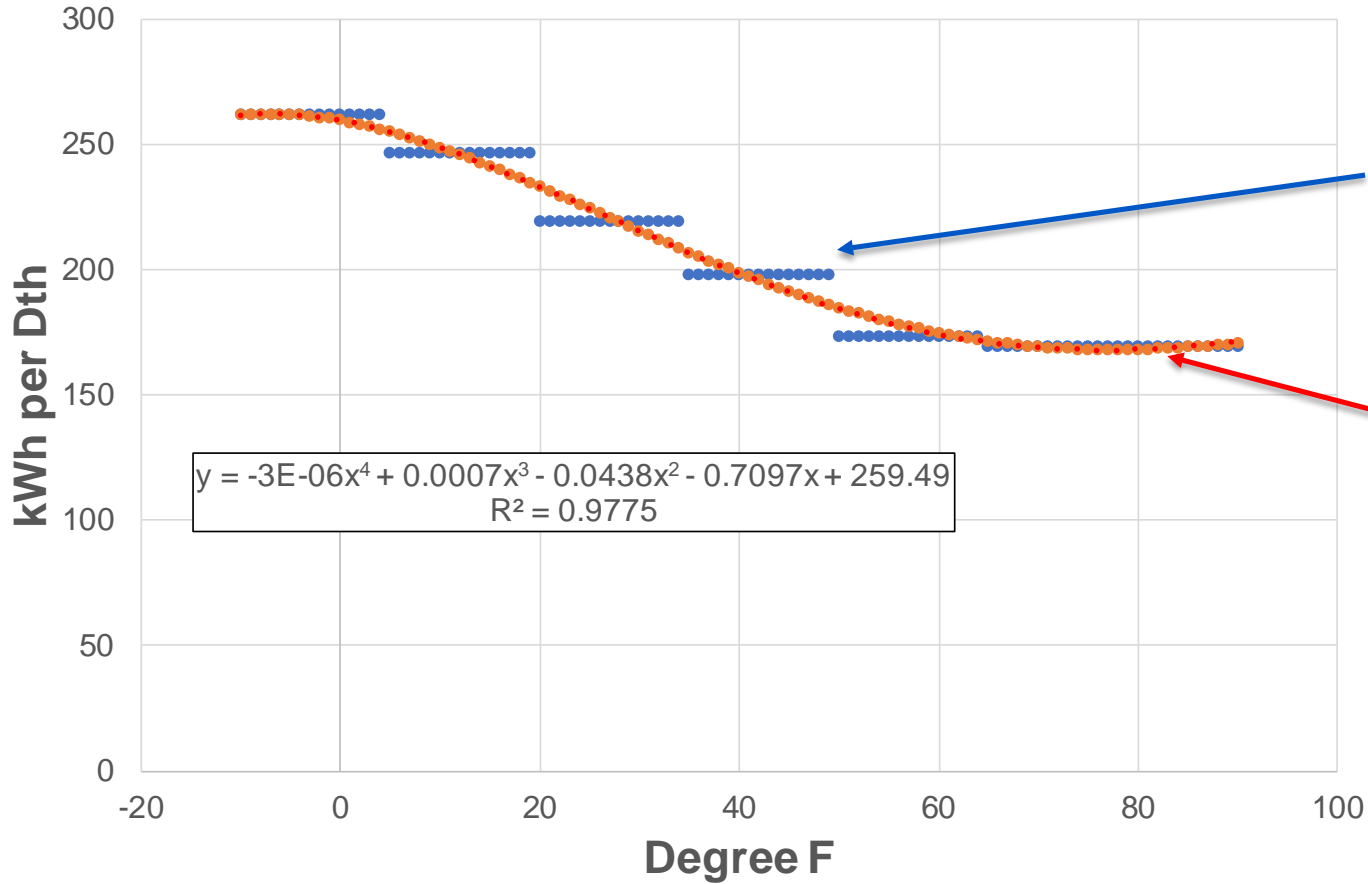

Use temperature point estimates for conversion efficiency

Curve fit to smooth out steps

# WA Res/Com Natural Gas Load Forecast

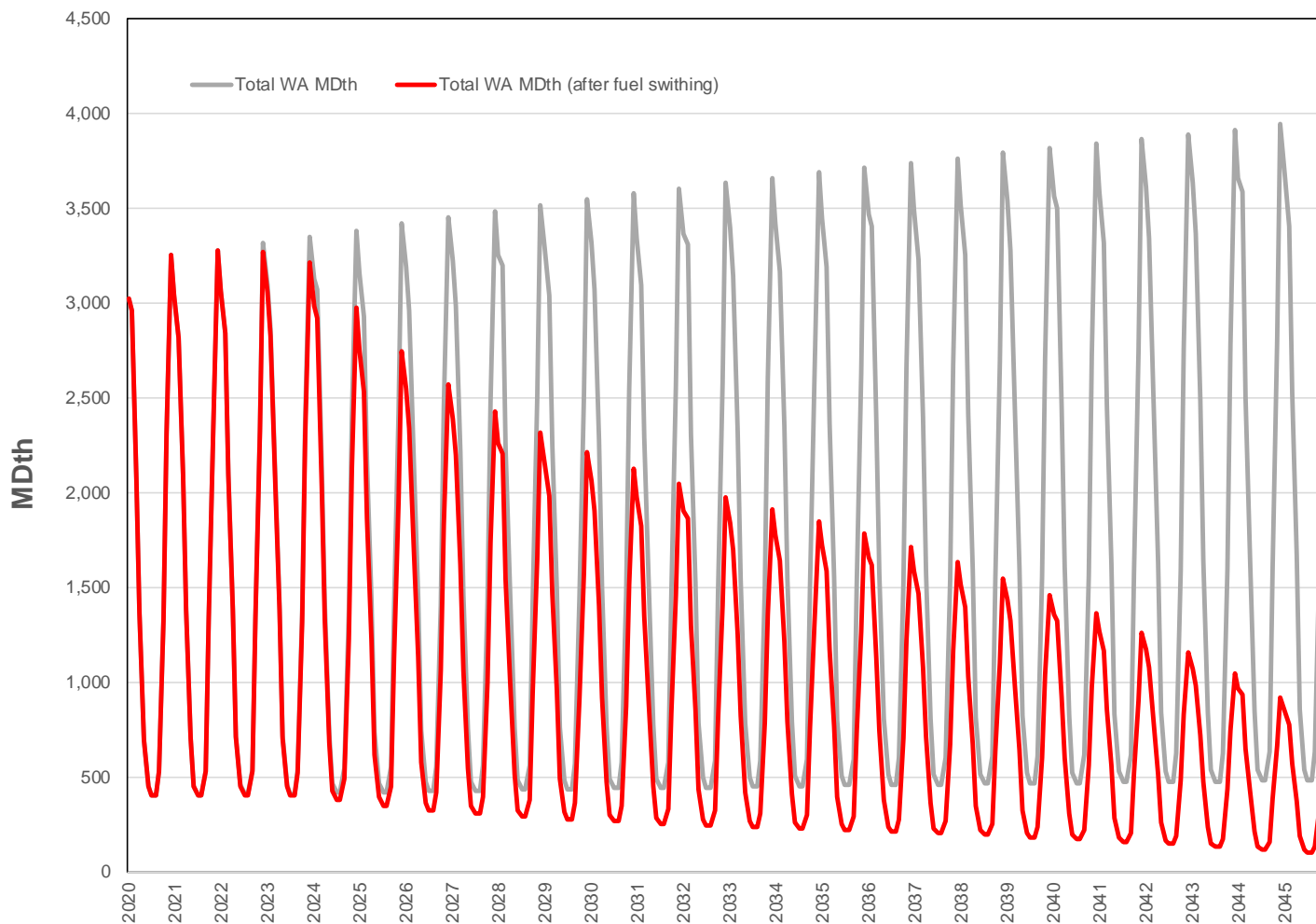

# Electric Peak Estimation Methodology

- Natural gas is typically daily nominations, while electric is instantaneous.
  - Hourly flow metering is available for some areas
- Sampled large gate-station hourly instantaneous natural gas flow data
- Use sample data to estimate hourly natural gas load from 2015-2019
- Estimate Peak-to-Energy load factor for each historical month
- Use average monthly load factor for the peak adjustment

# Estimated Load Factors (2015-19)

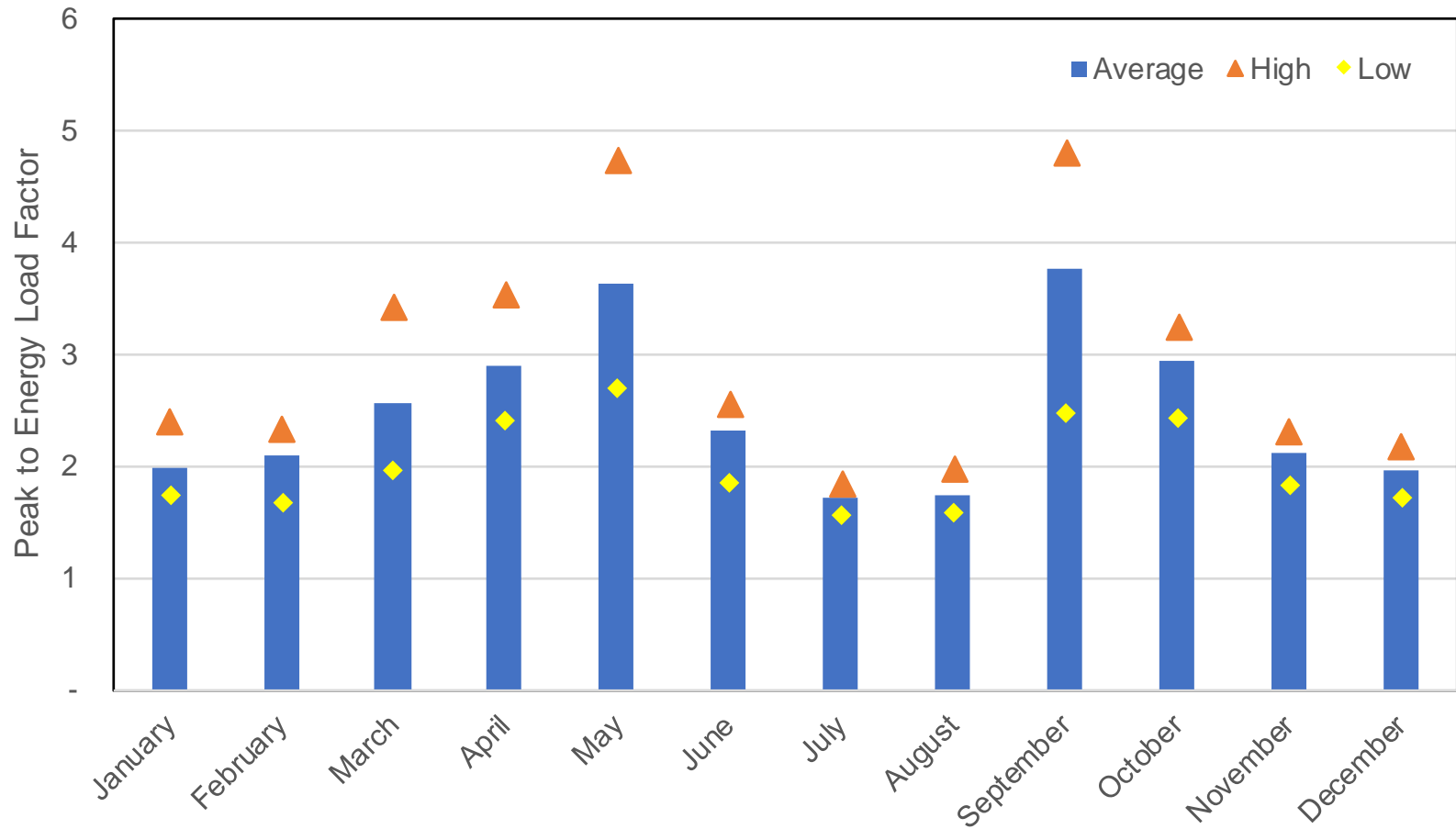

# Hourly Electric Load History

2015-2019 Control Area Load + WA LDC as Electric

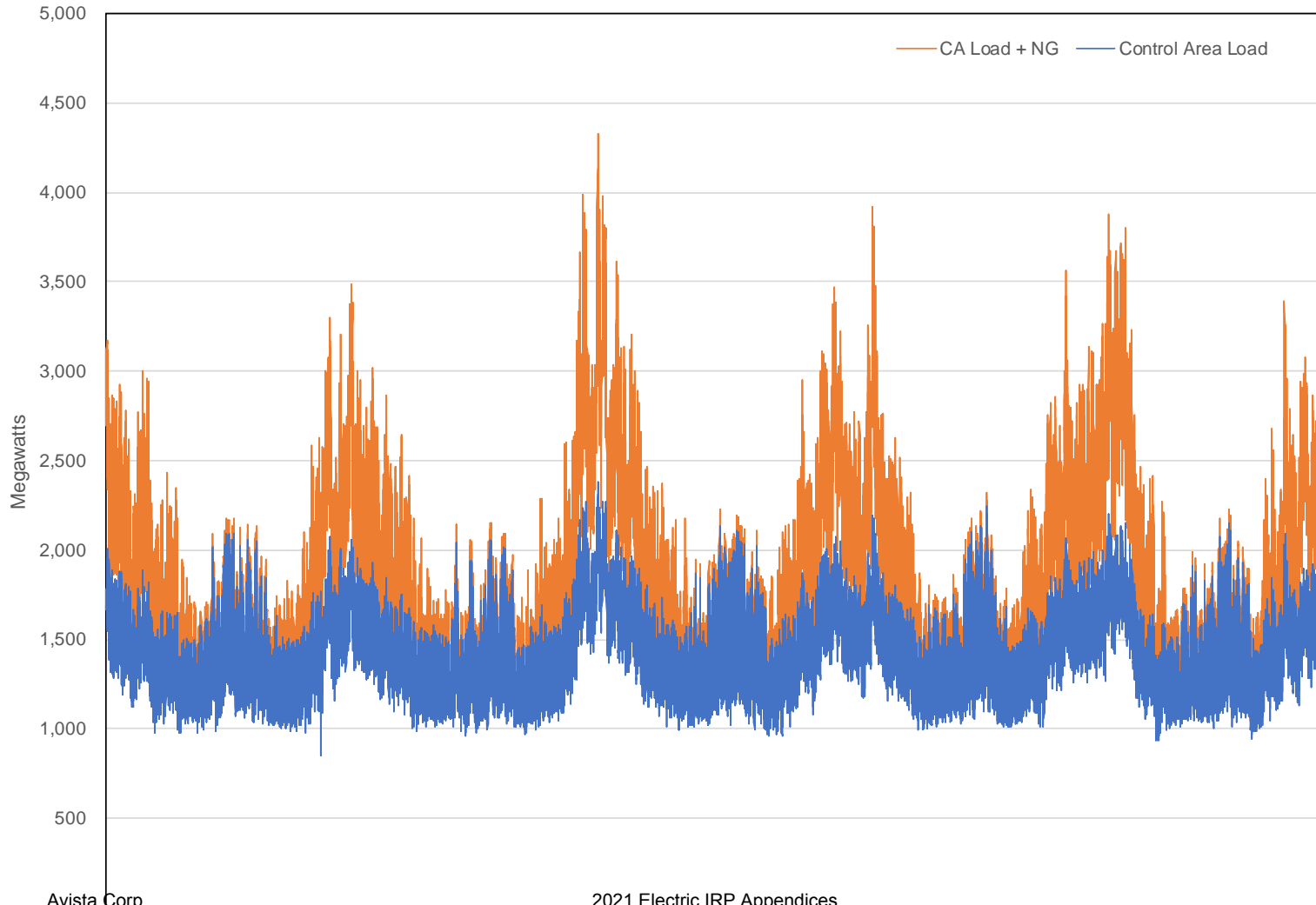

# Eastern Washington Electric Service Providers

EIA reported retail sales for 2018

Scenario assumes Avista will receive 75 percent of electric conversions

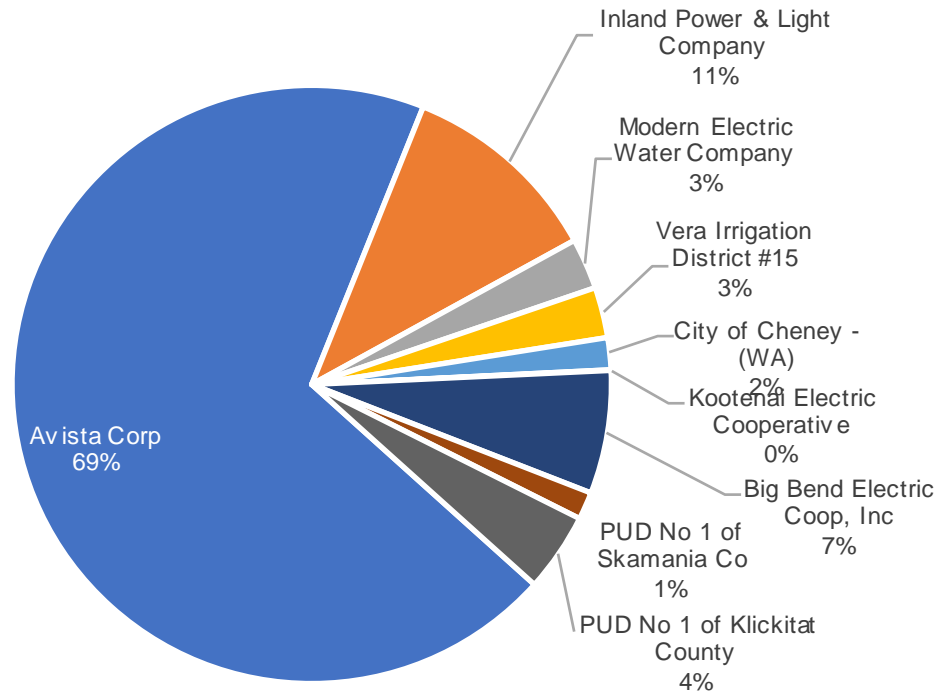



# Annual Conversion Load Forecast

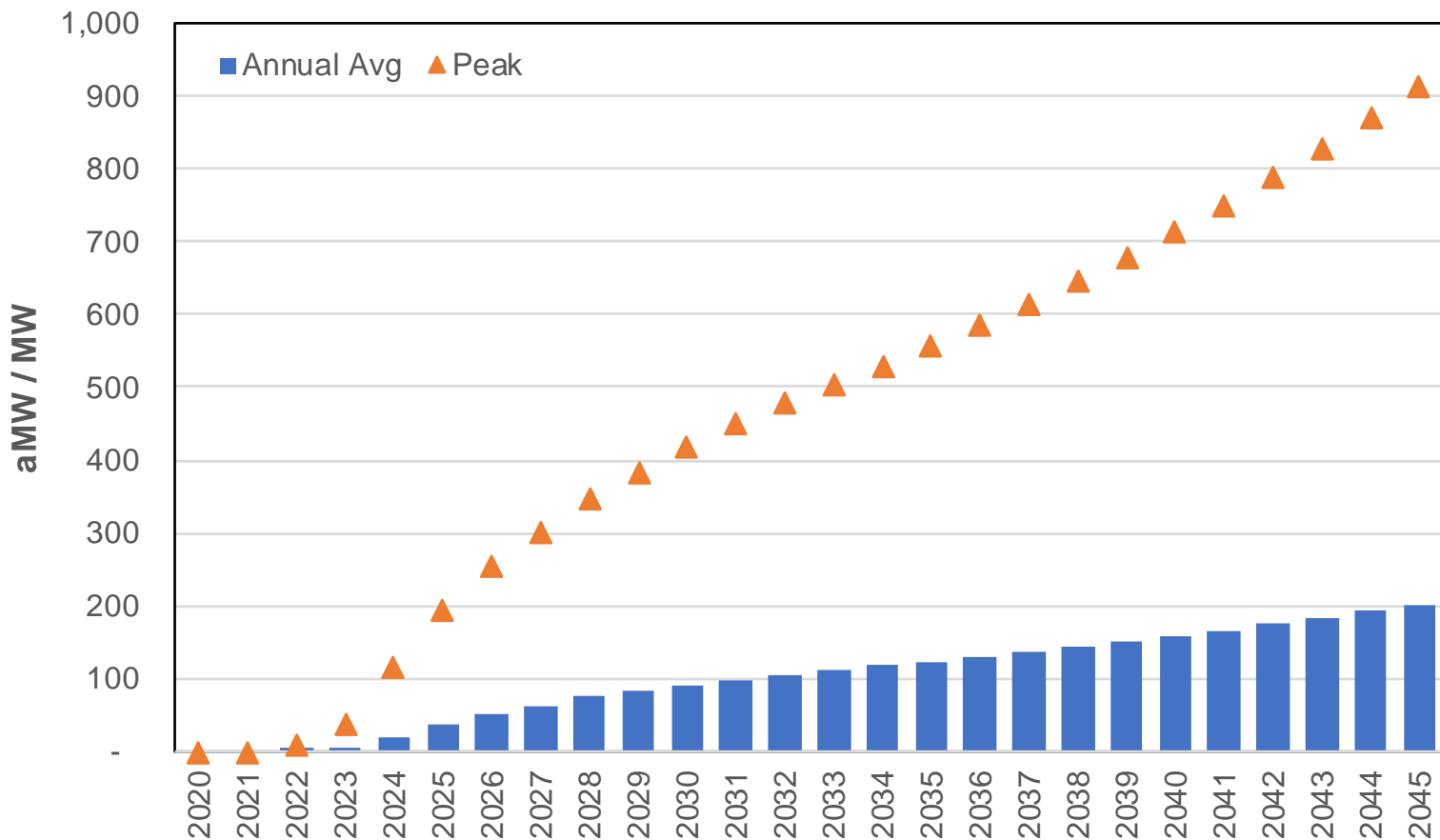

2020 IRP Forecast for 2030 absent fuel conversion:  
 Peak: 1,762 MW  
 Energy: 1,209 aMW



# 2030 Monthly Load Forecast

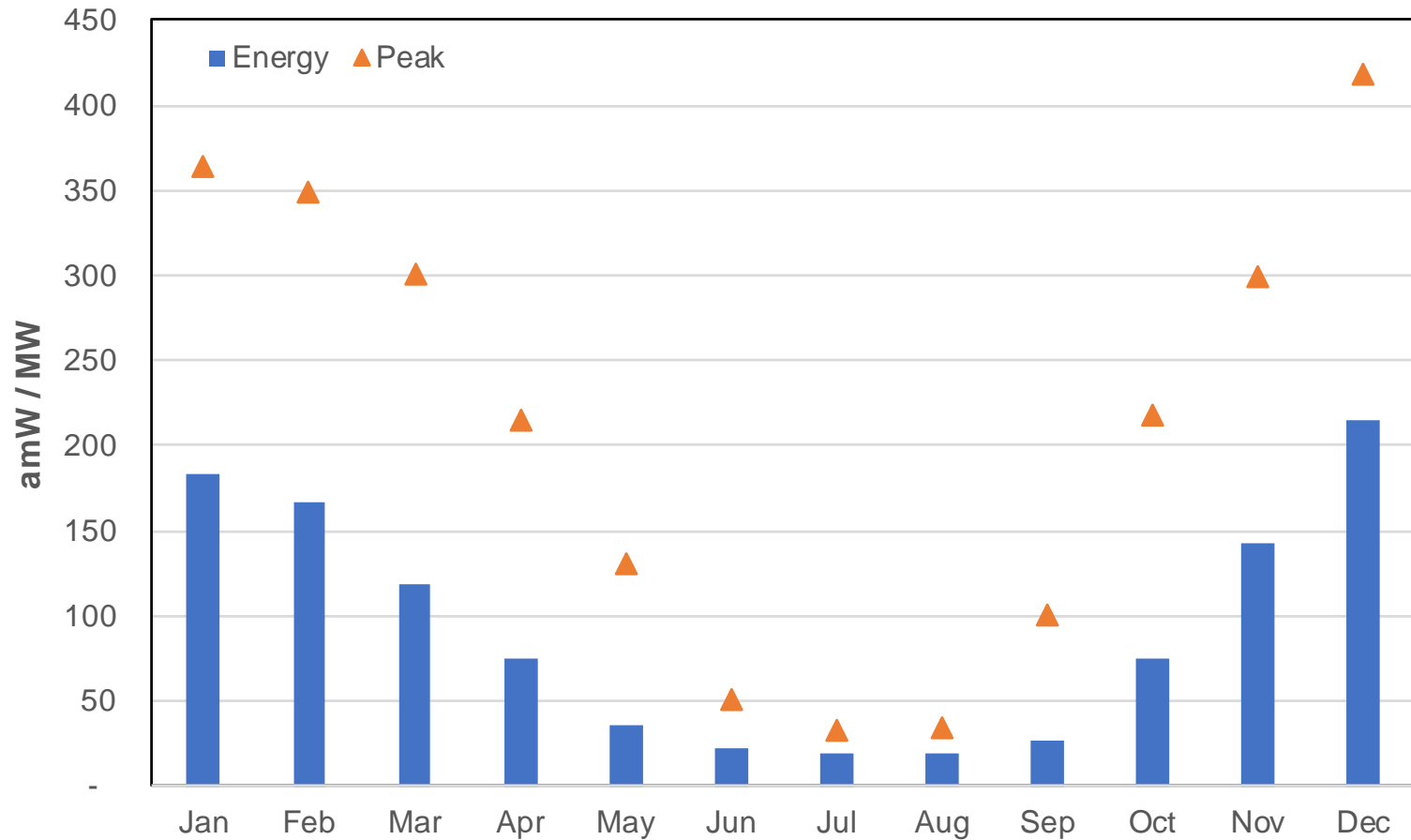

# Scenario Analysis- Conversion Rates

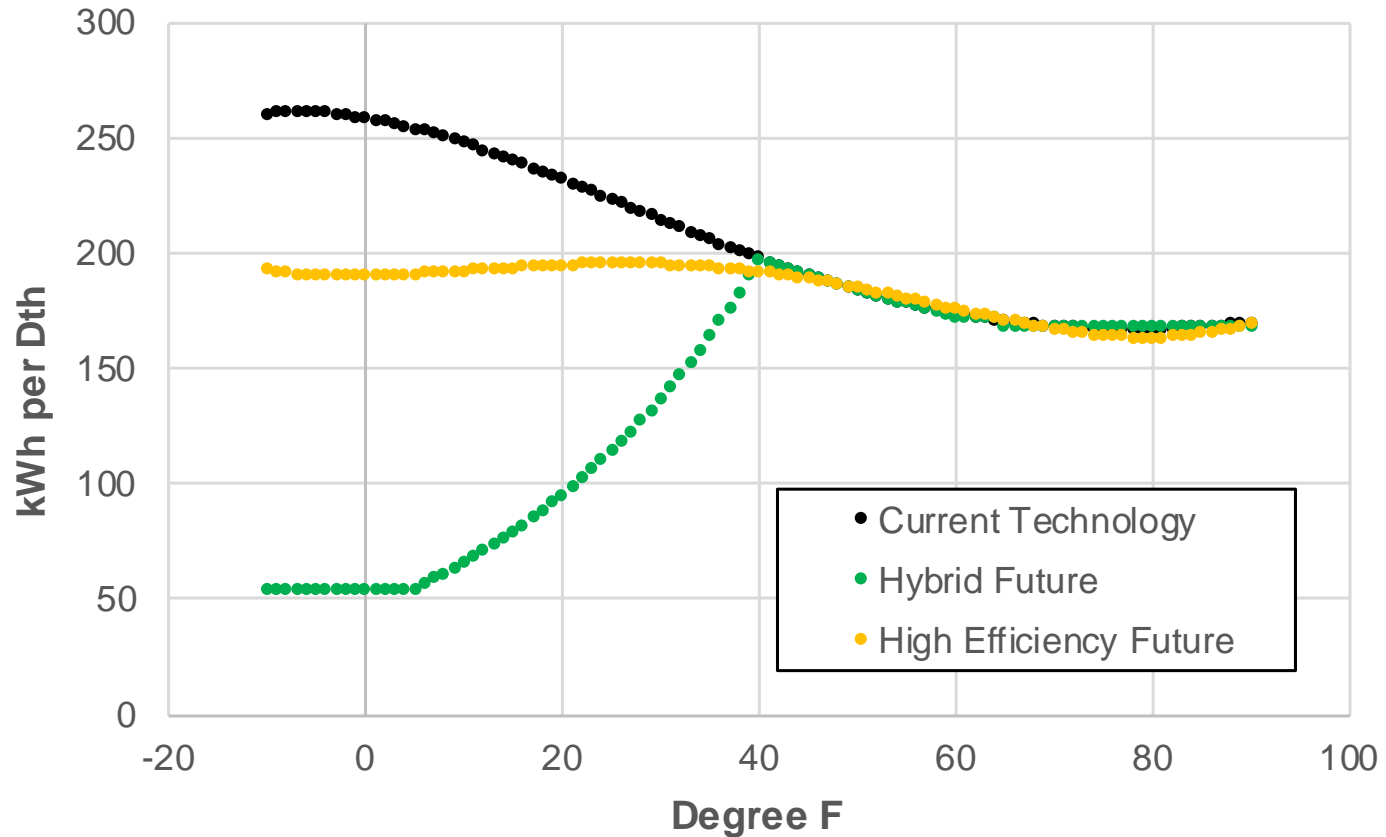

# Scenario Analysis- Electric Energy

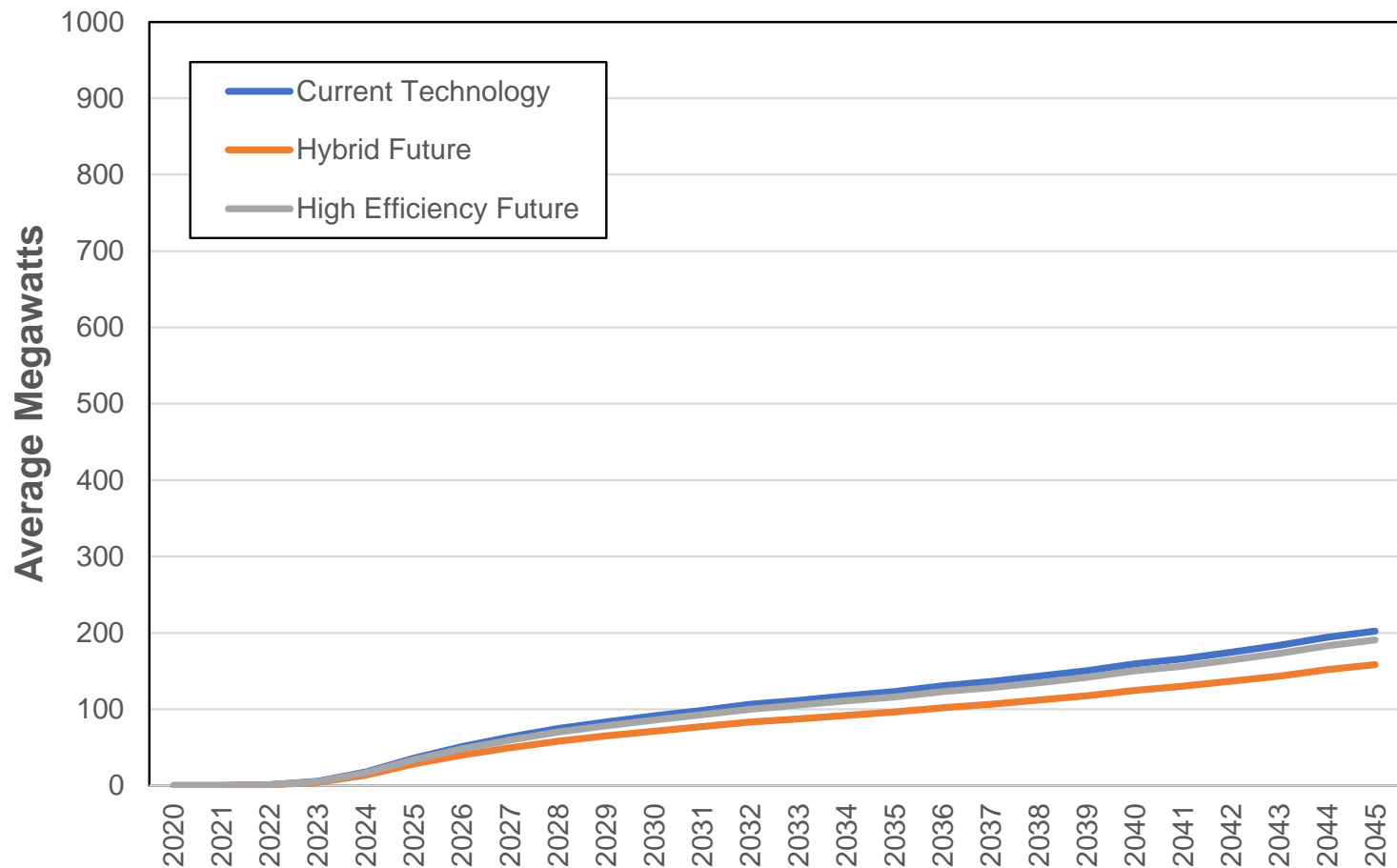

# Scenario Analysis: Electric December Peak Load

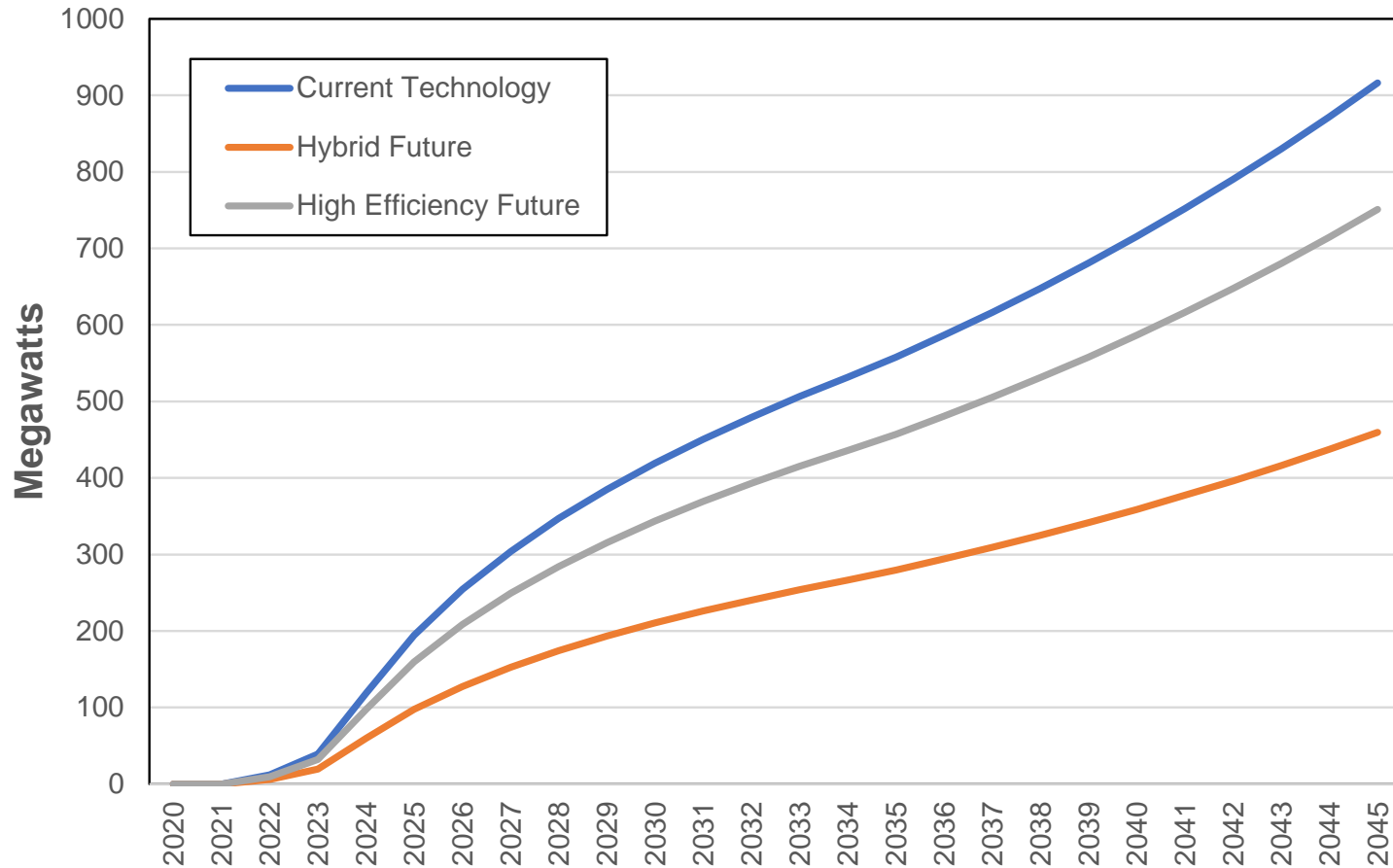

# Scenario Analysis: Natural Gas Demand

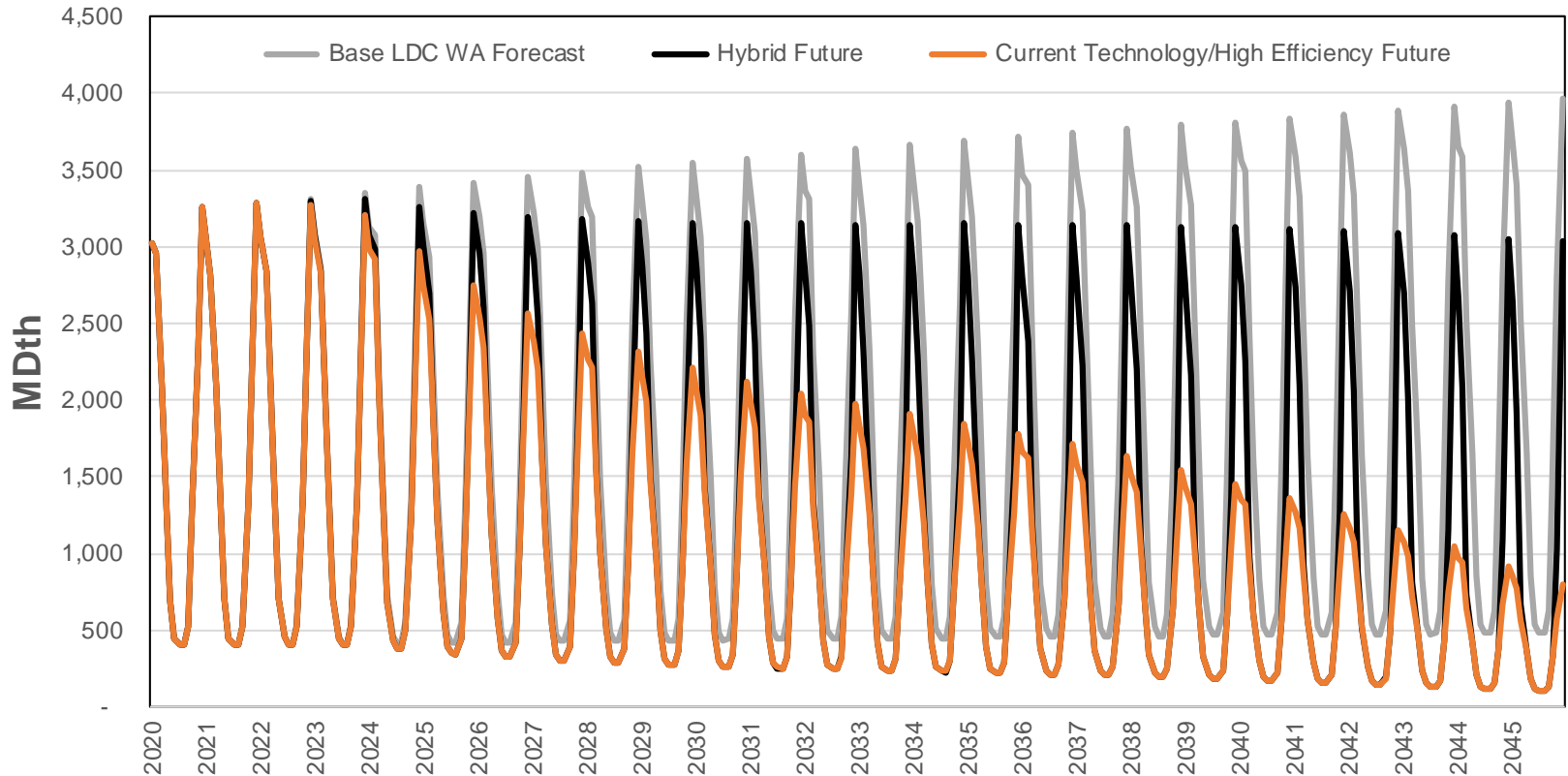

# Next Steps

- Input into PRiSM model to determine resource selection and cost
  - Estimate cost meeting CETA requirements
  - Estimate cost using least cost methodology
  - Estimate emissions savings
  - Estimate \$/tonne
- Conduct electric resource adequacy study if time permits



# 2021 Electric IRP Washington Vulnerable Populations & Highly Impacted Communities

James Gall, IRP Manager  
Second Technical Advisory Committee Meeting  
August 6, 2020



# Identifying Communities or “Customers”

## Highly Impacted Communities

- Cumulative Impact Analysis
- Tribal lands
  - Spokane
  - Colville
- Locations should be available by end of 2020
  - State held workshops in August & September 2019

## Vulnerable Populations

- Use Washington State Health Disparities map
  - What is disproportionate on a scale of 1 to 10?
  - Avista proposes areas with a score 8 or higher in either Socioeconomic factors or Sensitive population metrics
- Should we include other metrics to identify these communities?

# Environmental Health Disparities Map

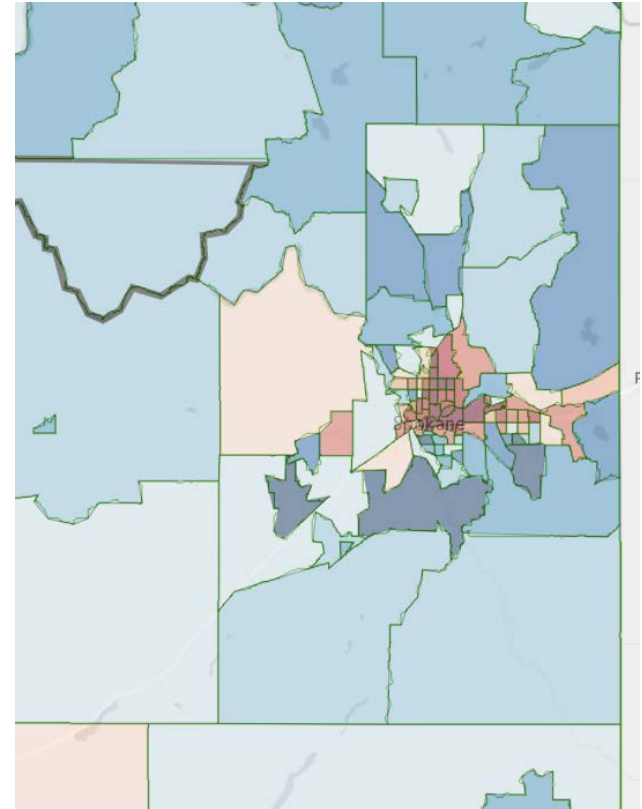
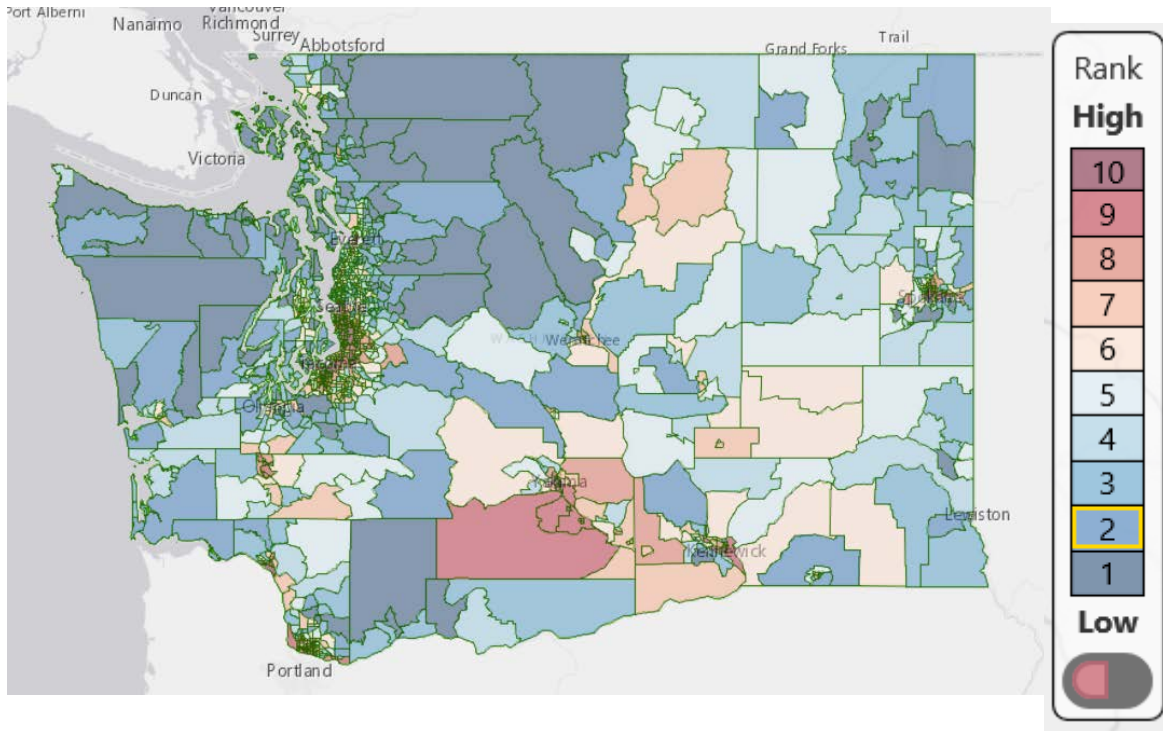

<https://fortress.wa.gov/doh/wtn/wtnibl/>

Department of Health data is divided up by Federal Information Processing Standards (FIPS) Code

# Environmental Health Scoring

## From WA Department of Health

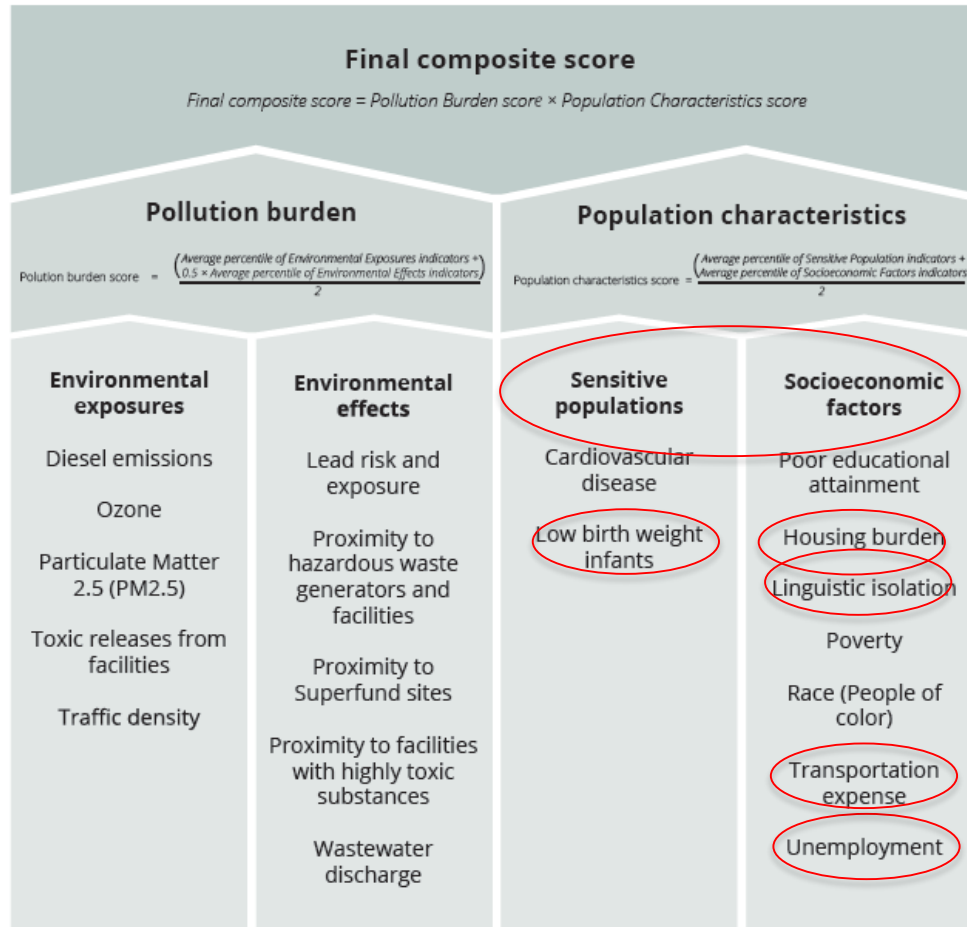

Circle areas match definition of vulnerable population, although access to food & health care, higher rates of hospitalization are not expressively included but are an indication of poverty

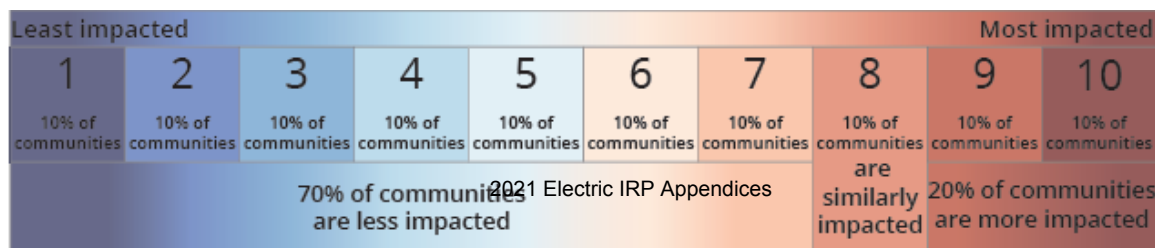

# Selected Vulnerable Populations

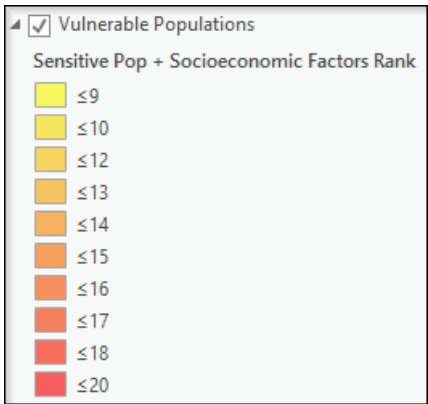

Data is shown by combined score

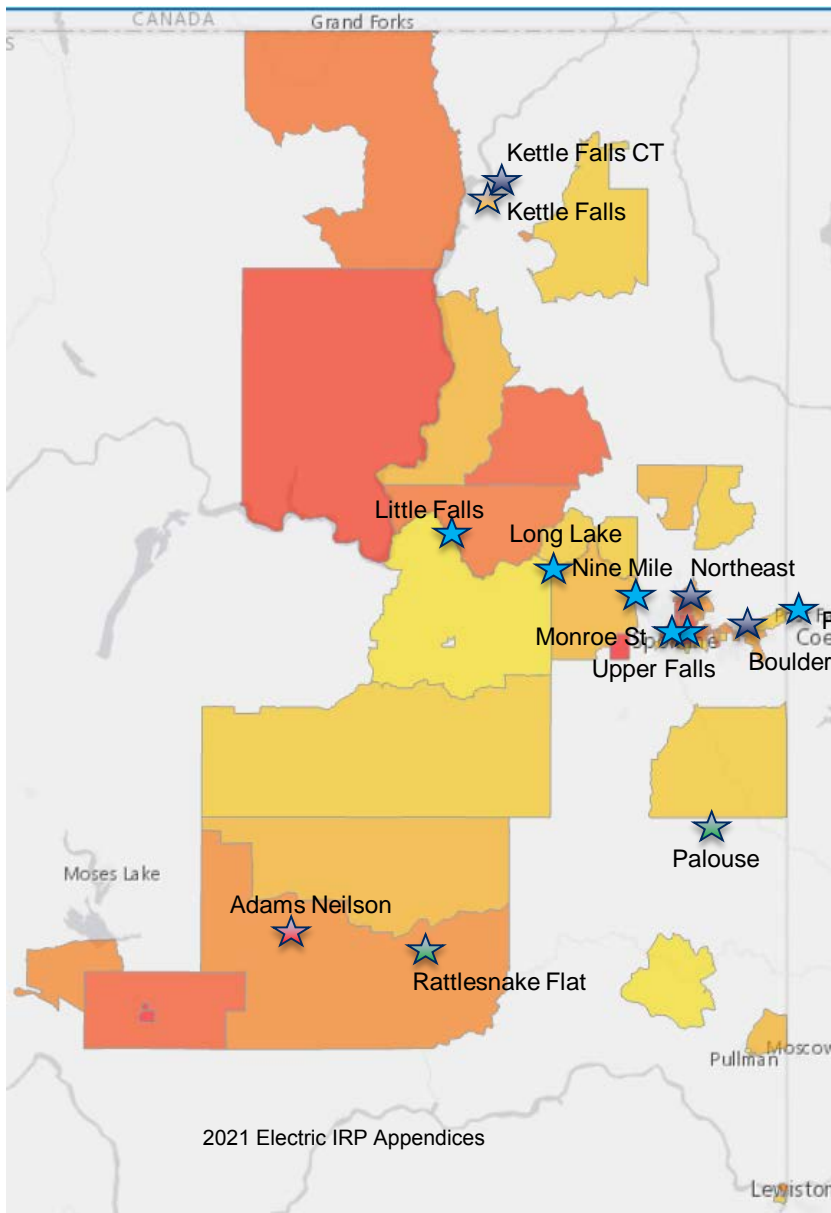

## “Large” Resource Legend

- Natural Gas
- Biomass
- Hydro
- Wind
- Solar



# Spokane Area “Avista” Vulnerable Populations

- ★ Natural Gas
- ★ Biomass/Other
- ★ Hydro
- ★ Wind
- ★ Solar

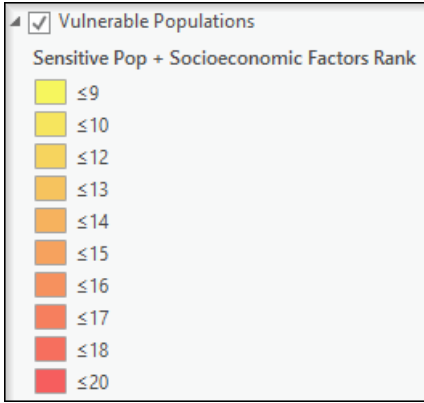

Data is shown by combined score

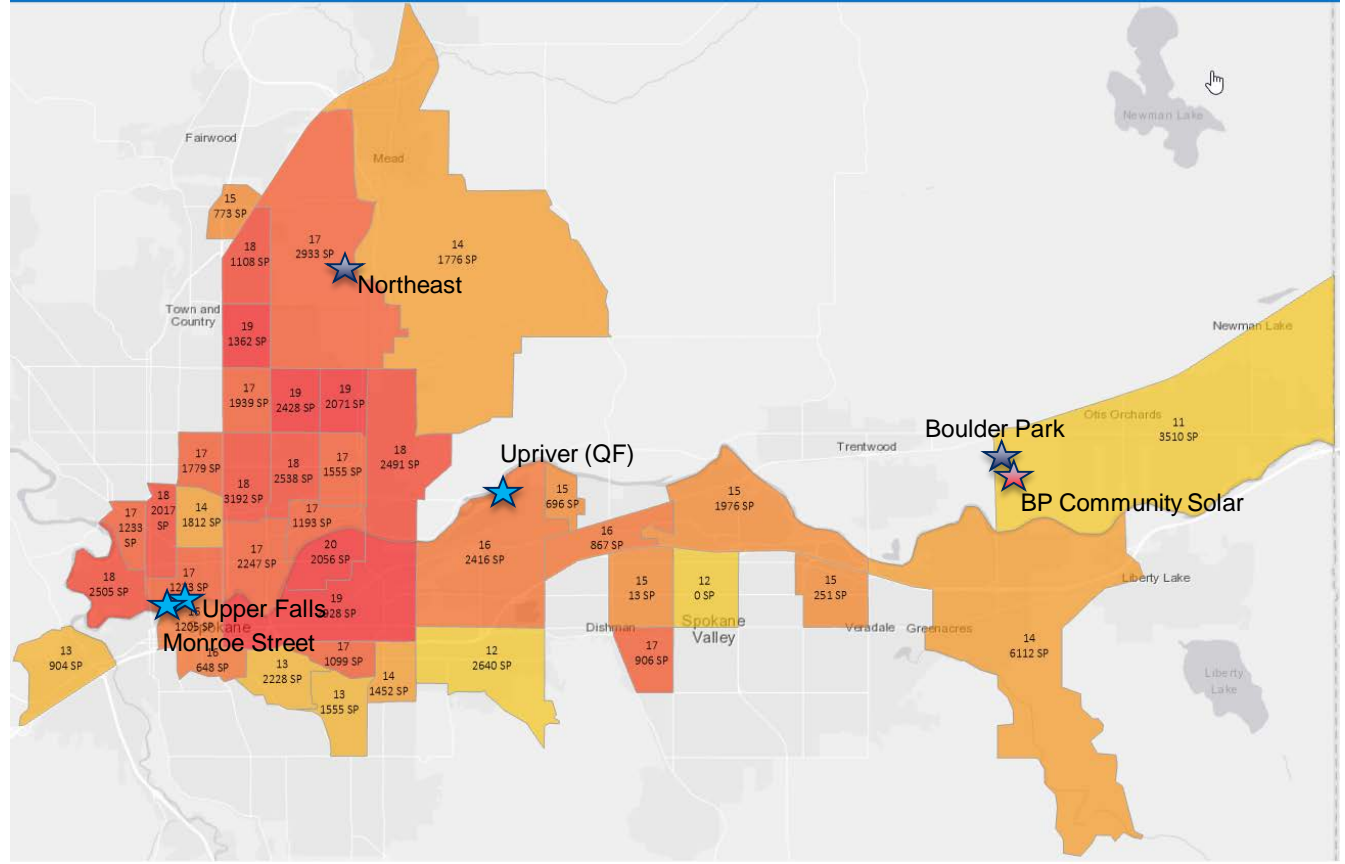

★ Waste-to-Energy (QF)



# IRP Metrics *(From Last TAC Meeting)*

Metric	IRP Relationship
Energy Usage per Customer	<ul style="list-style-type: none"> <li>• Expected change taking into account selected energy efficiency then compare to remaining population.</li> <li>• EE includes low income programs and TRC based analysis which includes non-economic benefits.</li> </ul>
Cost per Customer	<ul style="list-style-type: none"> <li>• Estimate cost per customer then compare to remaining population.</li> <li>• How do IRP results compare to above 6% of income?</li> </ul>
Preference	<ul style="list-style-type: none"> <li>• Should the IRP have a monetary preference?             <ul style="list-style-type: none"> <li>• For example- should all customers pay more to locate assets (or programs) in areas with vulnerable populations or highly impacted communities?</li> <li>• If so, how much more?</li> </ul> </li> </ul>

# IRP Metrics *(From Last TAC Meeting)*

Metric	IRP Relationship
Reliability <ul style="list-style-type: none"> <li>• SAIFI: System Average Interruption Frequency Index</li> <li>• MAIFI: Momentary Average Interruption Frequency Index</li> </ul>	<ul style="list-style-type: none"> <li>• Calculate baseline for each distribution feeder and match with communities</li> <li>• Estimate benefits for area with potential IRP distribution projects</li> </ul>
Resiliency: <ul style="list-style-type: none"> <li>• SAIDI: System Average Interruption Duration Index</li> <li>• CAIDI: Customer Average Interruption Duration Index</li> <li>• CELID: Customer's Experiencing Long Duration Outages</li> </ul>	<ul style="list-style-type: none"> <li>• Compare to other communities as baseline</li> <li>• May be more appropriate in Distribution plan rather than IRP</li> </ul>
Resource Analysis	<ul style="list-style-type: none"> <li>• Estimate emissions (NO<sub>x</sub>, SO<sub>2</sub>, PM2.5, Hg) from power projects located in/near identified communities</li> <li>• Identify new resource or infrastructure project candidates with benefit to communities; i.e. economic benefit, reliability benefit</li> <li>• Identify how resource can benefit energy security</li> </ul>

# Energy Use Analysis Results

- Uses five years of customer billing data
- Median income over the same period is used to estimate affordability
- Separated electric only vs electric/gas customers
  - Future enhancement include single/multi family homes, and manufactured homes



# Energy/Cost Analysis

## Electric Only Customers

Area	Fuel Type	Energy Use	Avg Bill	Income	% Income
Vulnerable Population Areas	Electric	998 KWh	\$98	\$42,730	2.8%
Other Areas	Electric	1,010 KWh	\$100	\$58,834	2.0%

*Note: Mean energy use is statistically significantly different when removing energy use data below 100 kWh per month (1,049 kWh vs 1,082 kWh)*

## Natural Gas/Electric Customers

Area	Fuel Type	Energy Use	Avg Bill	Income	% Income
Vulnerable Population Areas	Electric	820 KWh	\$80		
Other Areas	Electric	875 KWh	\$84		
Vulnerable Population Areas	Gas	52 Therms	\$47	\$44,889	3.4%
Other Areas	Gas	62 Therms	\$56	\$68,250	2.5%

*Note: Combined natural gas/electric homes have higher energy burden due to fewer multifamily homes included in the population or all electric home including homes with alternative heat such as wood, propane, oil, pellets. Future analysis needed to validate this hypothesis.*

# Vulnerable Populations

## Electric Only Customers- Energy % of Income

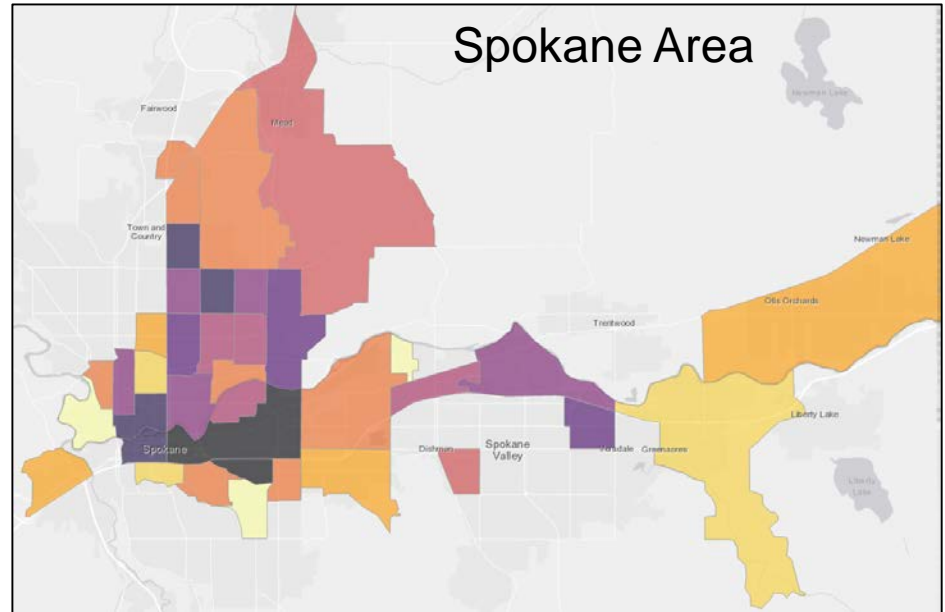
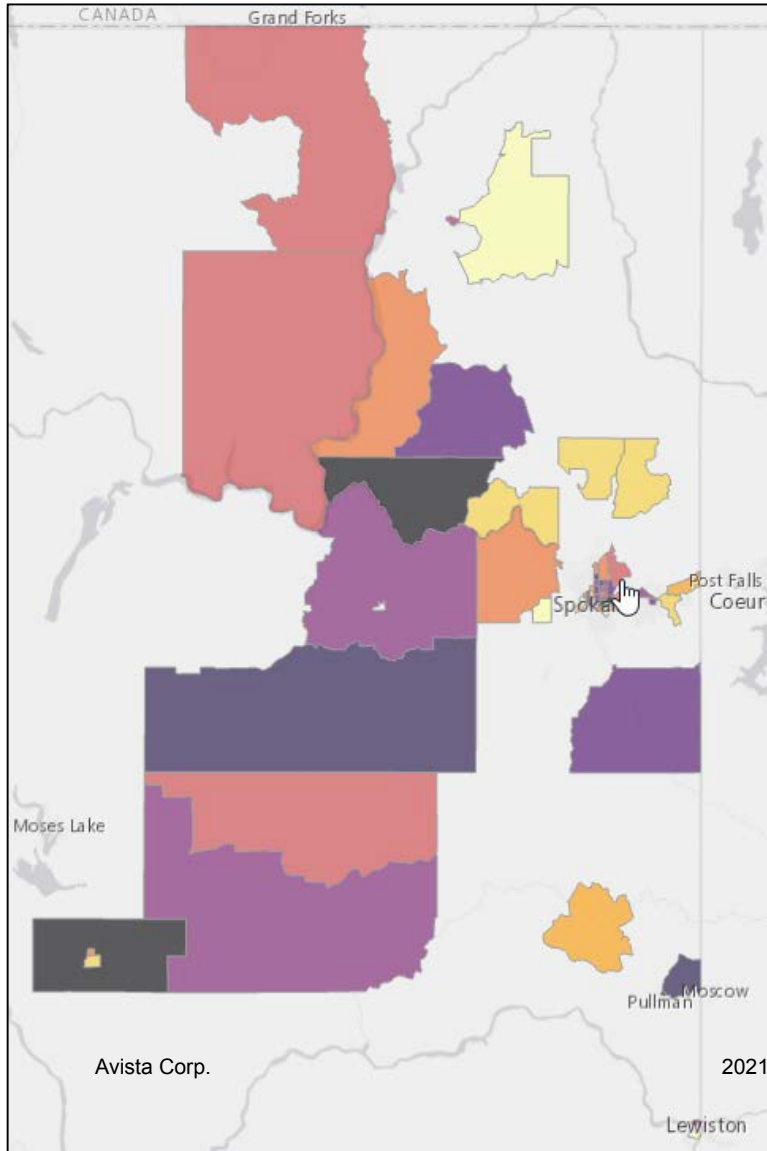

Energy Cost as % of Income - Electric Only

5 Year Avg for Electric Only Customers

- ≤ 2.08 %
- ≤ 2.24 %
- ≤ 2.41 %
- ≤ 2.56 %
- ≤ 2.69 %
- ≤ 2.95 %
- ≤ 3.12 %
- ≤ 3.34 %
- ≤ 3.84 %
- ≤ 4.27 %



# Vulnerable Populations

## Gas/Electric Only Customers- Energy % of Income

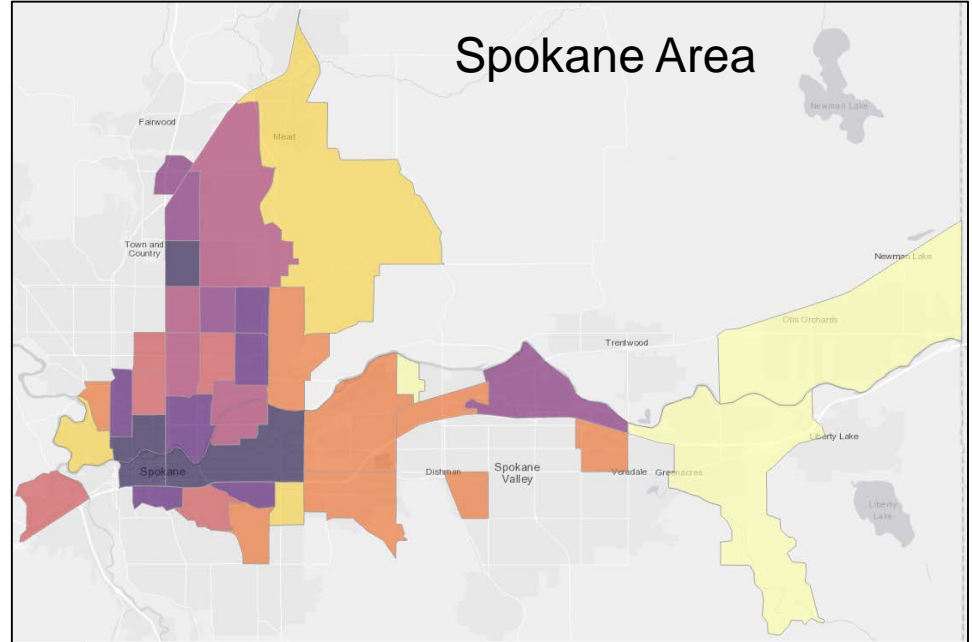
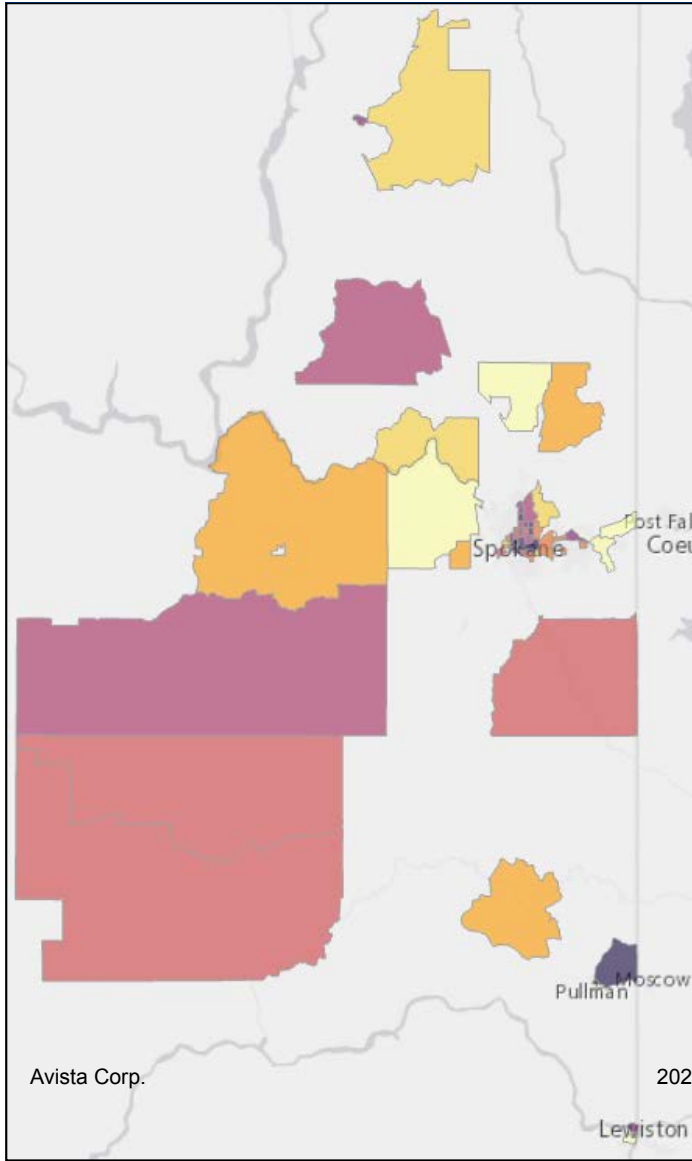

Energy Cost as % of Income - Electric & Gas

5 Year Avg for Customers with Both

- ≤ 2.64 %
- ≤ 2.81 %
- ≤ 3.04 %
- ≤ 3.32 %
- ≤ 3.66 %
- ≤ 4.01 %
- ≤ 4.49 %
- ≤ 5.10 %
- ≤ 7.92 %
- ≤ 11.07 %

# Reliability Data- CAIDI

Measure of resilience- minutes of outages per event  
Excludes Major Event Days (MED)

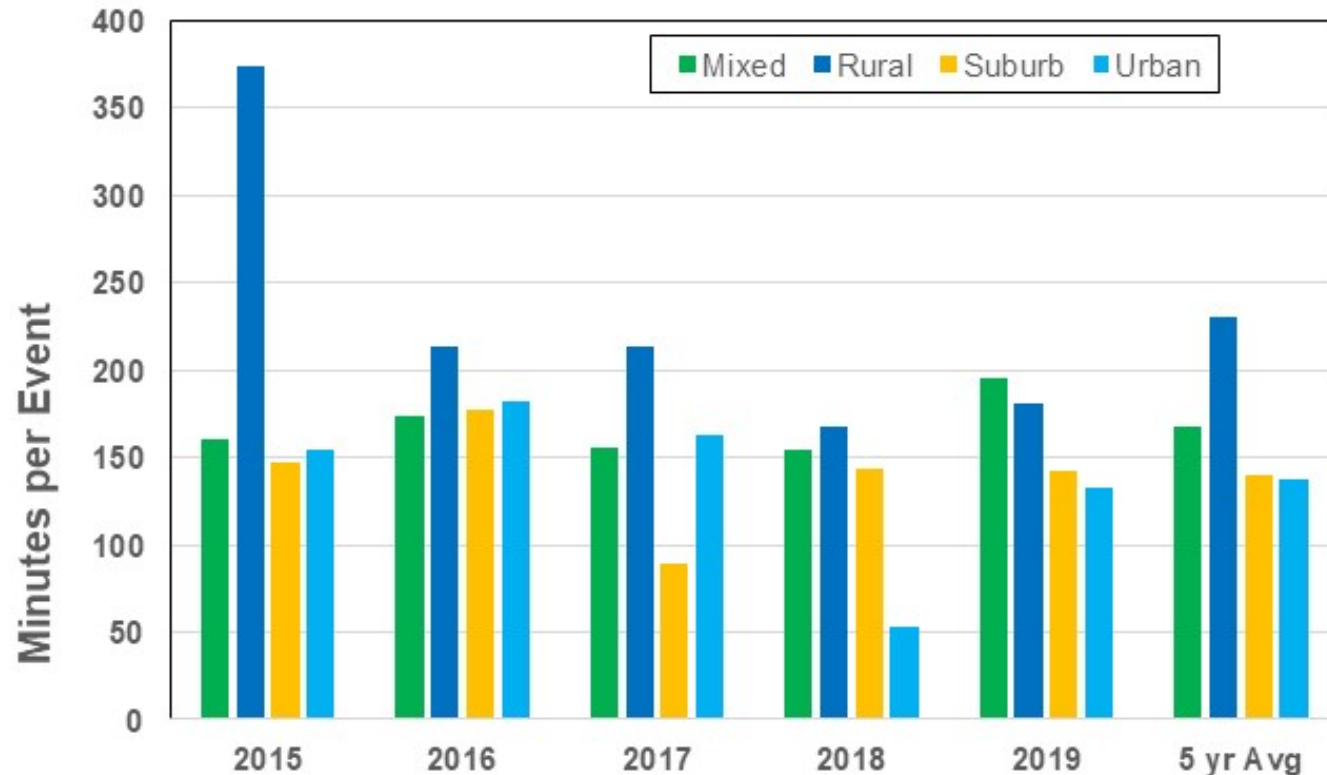

# Reliability Data- CEMI

Measure of reliability- Events per Customer

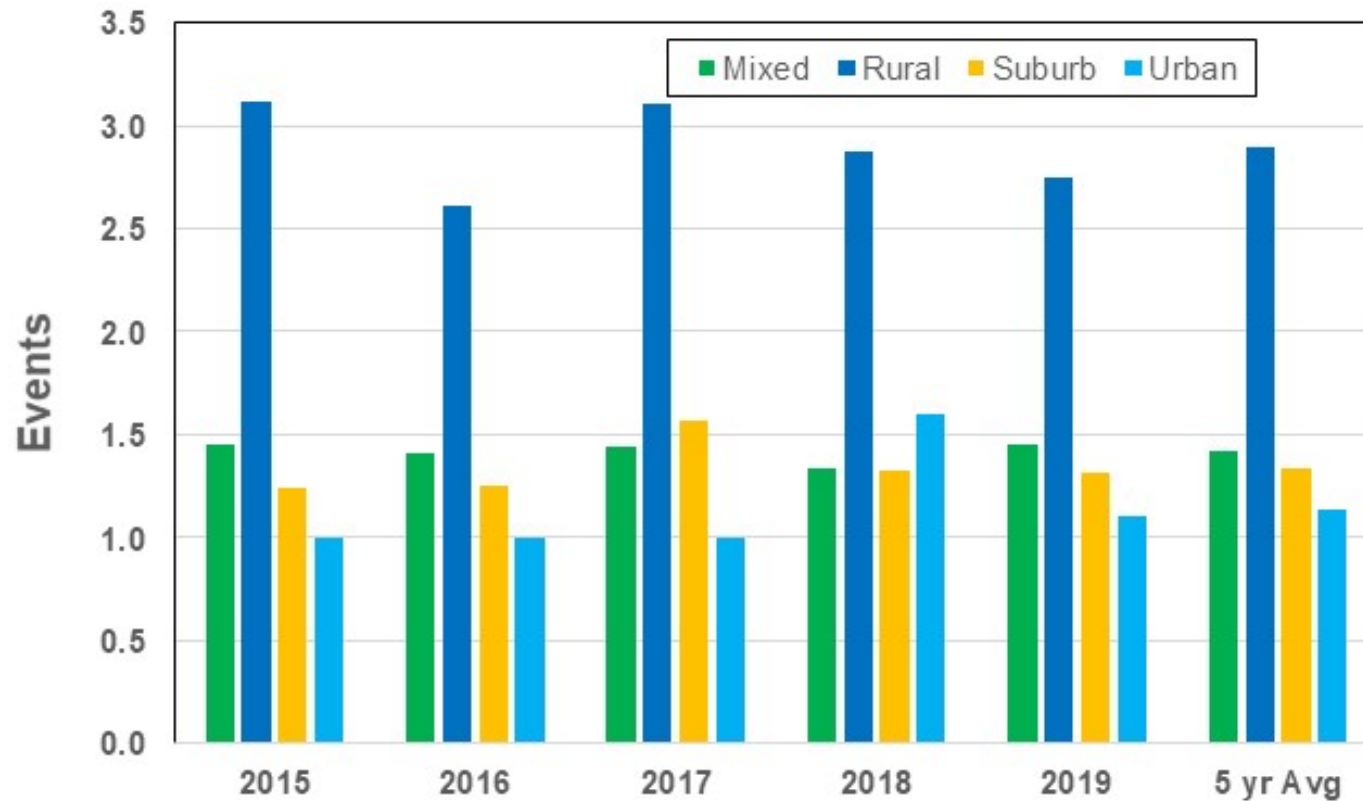

# Vulnerable Area vs Non Vulnerable Areas

## CAIDI

## CEMI

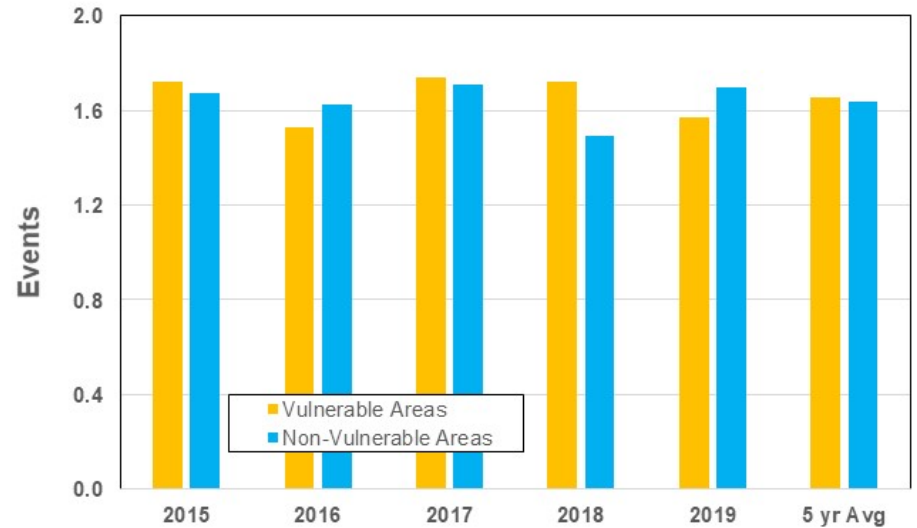
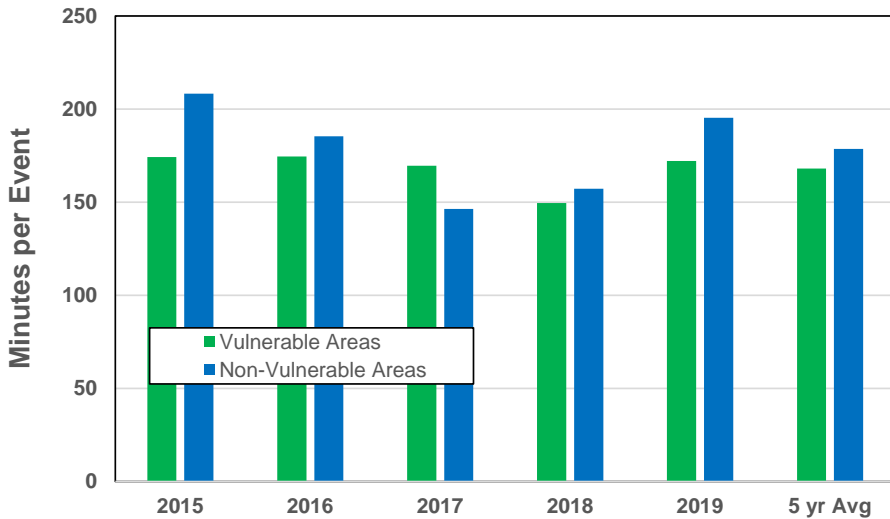

Note: 5 yr Average differences are statistically significantly different

# CAIDI- By Feeder Type

Mixed Feeders

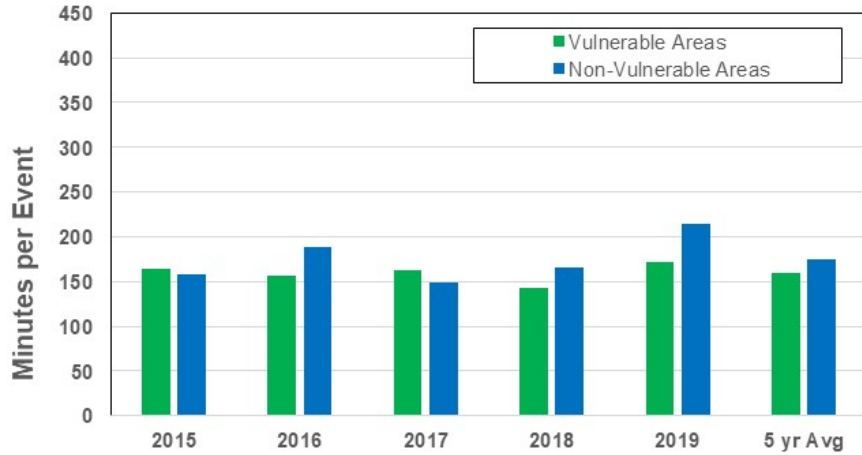

Rural Feeders

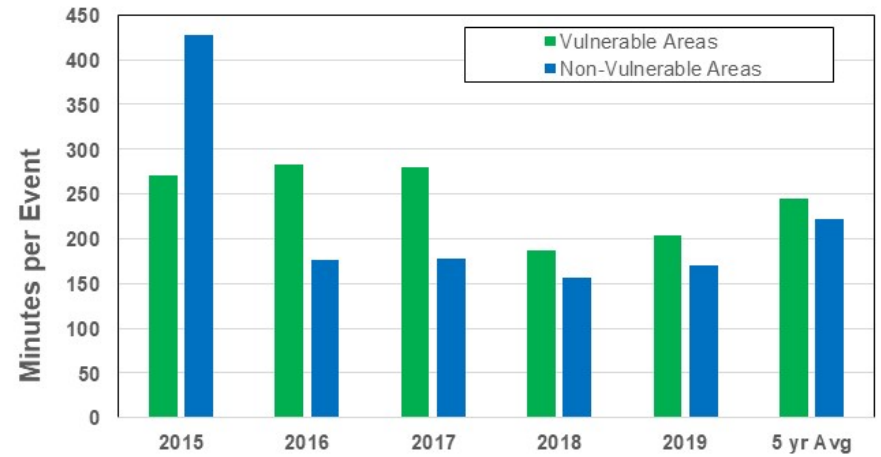

Suburban Feeders

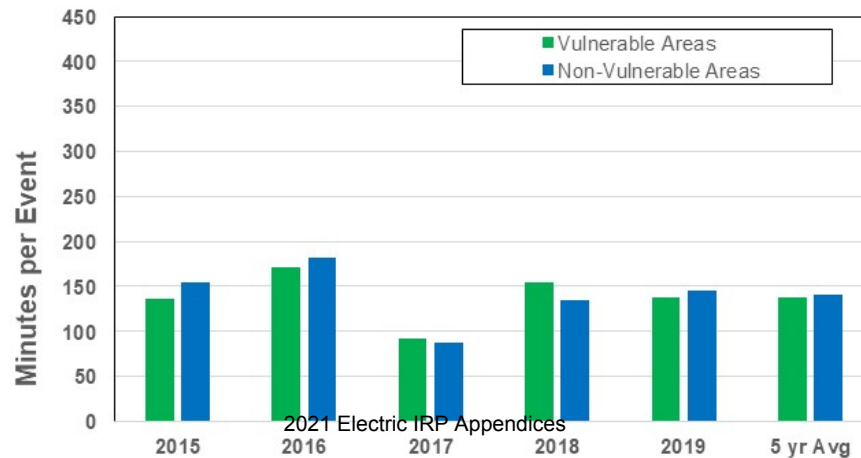

Note: Avista has no vulnerable areas with urban feeders  
Avista Corp.



# CEMI- By Feeder Type

Mixed Feeders

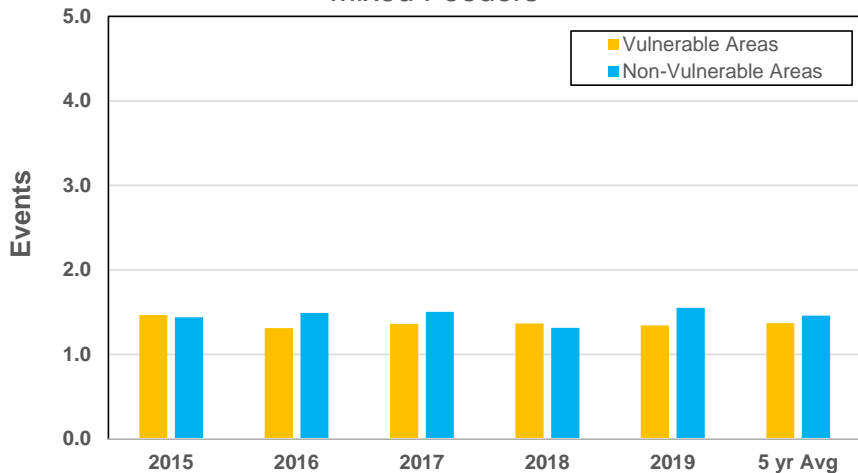

Rural Feeders

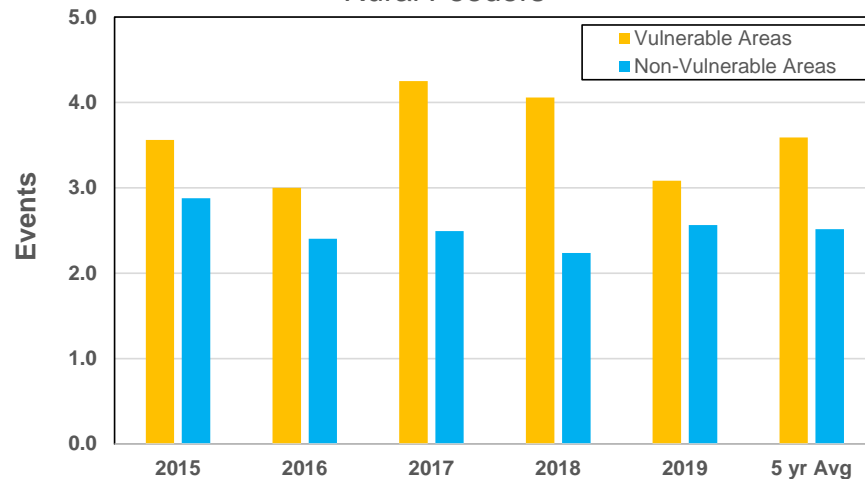

Suburban Feeders

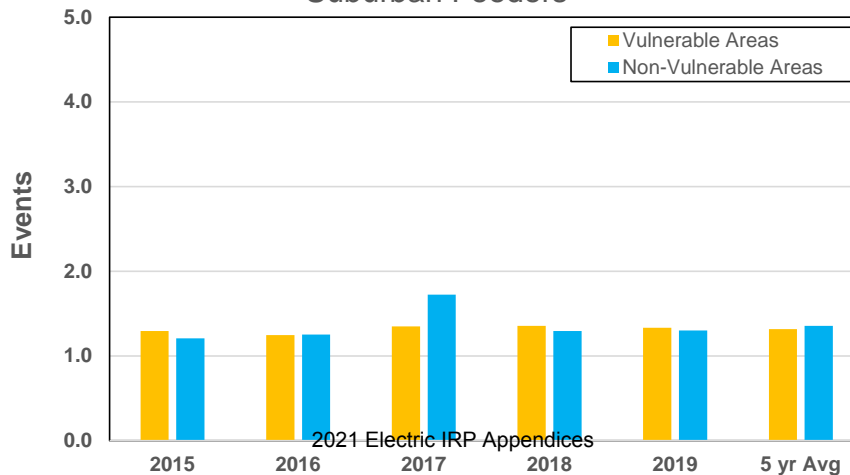

Note: Avista has no vulnerable areas with urban feeders  
Avista Corp.

2021 Electric IRP Appendices





# Avista's Washington Power Plant Air Emissions

Washington SO2 Emissions

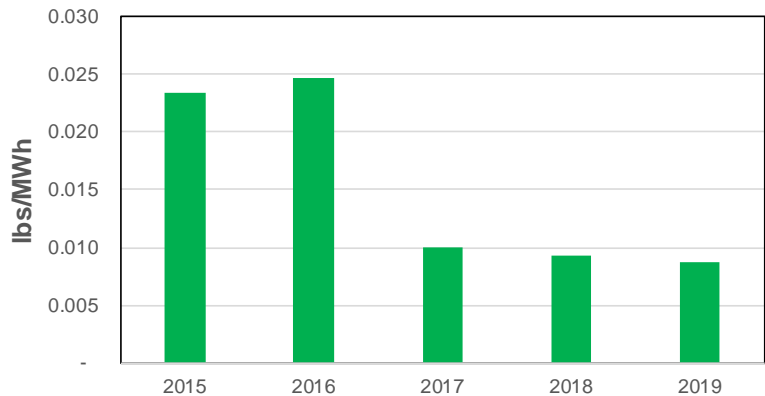

Washington NOx Emissions

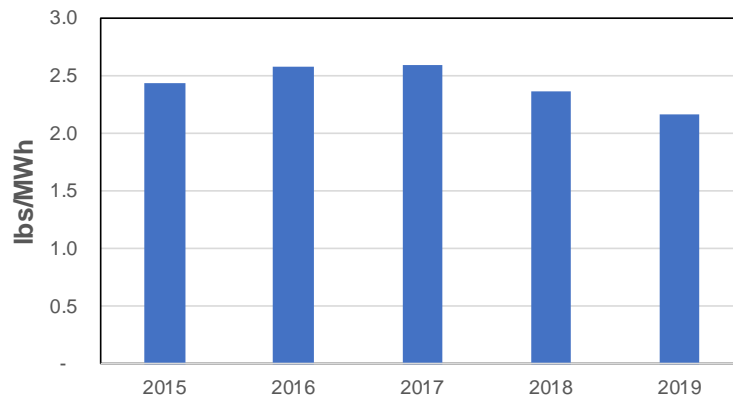

Washington Hg Emissions

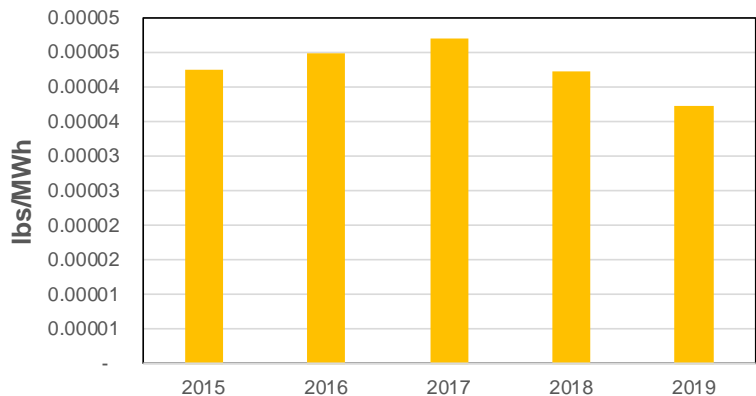

Washington VOC Emissions

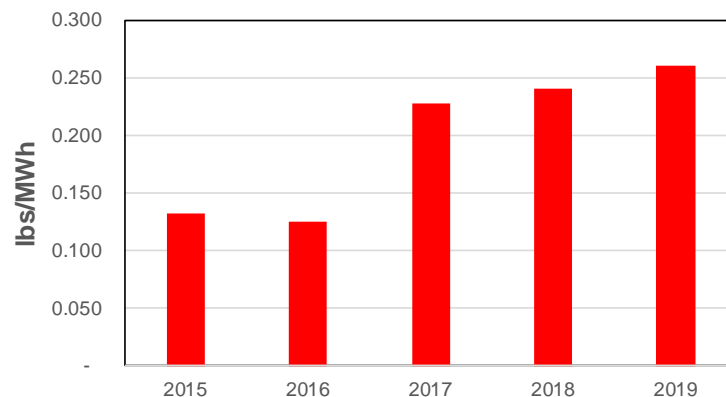

# TAC Input

- What other metrics can we provide in an IRP to show vulnerable populations and highly impacted communities are not harmed by the transition to clean energy

## **Second Technical Advisory Committee Meeting, Thursday, August 6, 2020**

**Virtual Attendees:** James Gall, Lori Hermanson, John Lyons, Tom Pardee, Rachelle Farnsworth, Greg Nothstein, Dainee Gibson, John Chatburn, Mike Morrison, Terri Carlock, James McDougall, Michael Brutocao, Paul Kimball, State of Idaho (x2), Steve Vincent, Nikita Bankoti, Chip Estes, Joana Huang (UTC), Terrence Browne, Leona Haley, Jody Morehouse, Scott Kinney, Corey Dahl, Katie Pegan, Sellers-Vaughn (Casc); Joni Bosh, Devin McGreal, Vlad Gutman-Britten; Steven Simmons, Jennifer Snyder, Morgan Brummund, Max St. Brown (OPUC), Jorgen Rasmussen, Jorgen; Heutte, Fred Heutte (NVEC); Sudeshna Pal (CUB), Brian Robertson, A. Argetsinger, Guest (18), Kaylene Schultz, Grant Forsyth, Anna Kim (OPUC), Dan Kirschner, Katie Ware, Matt Nykiel, Ken Ross, Ashton Davis, and Steve Johnson (UTC).

Notes in *italics* are short responses from the presenters and notes with brackets [ ] and times after them were pulled from the chat function on Skype.

### **Introductions and IRP Process Updates, John Lyons**

**Matt Nykiel:** What is the study request deadline for gas?

**Tom Pardee:** No formal deadline. Feel free to forward to me. We will be running gas models after this meeting and they will be presented at TAC 3. Gas will show CPA results at the November meeting, but will share some things earlier such as measure list.

### **Natural Gas & Renewable Natural Gas Market Overview, Tom Pardee**

**Matt Nykiel:** Since Avista gets a lot of gas from Canada, how is legislation impacting pricing and imports? Do you have general thoughts on this?

**Tom Pardee:** Haven't heard of that. Wood-Mac does include legislation in their fundamentals based forecast. What does the legislation entail?

**Matt Nykiel:** Carbon tax on gas essentially. How is this impacting the market in Canada and what we get from them, the reverberating impacts to price? It is important to keep on our radar as we're evaluating for Avista.

**Tom Pardee:** Yes, British Columbia has a carbon tax. We will look into this specifically and get back to the TAC.

**Fred Heutte:** Thanks for a very thorough survey. What are you seeing in near-term gas prices in 1, 2, 3 years due to COVID? Rig counts are dependent on early production in particular for Canadian short-term. There are a lot of ways it could go.

**Tom Pardee:** Canada has the lowest marginal costs for natural gas. There are a lot of liquids, not specifically drilling for natural gas but for oil so they need volumes to offset the high capital. They have a low break-even cost and so much capital is already invested, so they'll be slower to react to pricing changes than the northeast and the US.

For oil or bitumen, they are based on the breakeven cost for liquids and oil. Dry gas is mostly about getting that out as cheap as possible.

**Fred Heutte:** That is helpful. Is Avista broadly speaking, sourced more from Alberta or BC? What is going on in the Canadian Basin?

**Tom Pardee:** Alberta is mostly liquids and BC, Motney, etc. is dryer. Broadly, Avista is AECO mostly.

**Fred Heutte:** So, not as much as Sumas. Thanks.

**Nikita Bankoti (Slide 16, US demand):** That is a lot of information to process. Seems to be increases in LNG exports, will Avista be procuring more LNG?

**Tom Pardee:** Across all areas across all sectors, if you take away LNG exports, it's mostly staying the same. If gas started coming in large increments from Canada, that'd have a huge impact on us since we get 90% of our supply from Canada. In the US everything is hedged financially at Henry Hub. Simple supply – Canada is king around here, gas is cheap. Alberta is main economic driver, at least 50%. If there were an issue, it'd come from Alberta. Does that help?

**Nikita Bankoti:** Yes, thank you so much.

**Steve Johnson:** To reduce to a more simple understanding, most of the growth in demand will be from LNG exports.

**Tom Pardee:** Yes, that's a fair statement.

**Steve Johnson:** There's a lot of LNG exporters in the world. The US will become the number one exporter if all of these planned projects come to fruition. The cost for gas here rises and negatively impacts LNG going forward. Most investors think gas prices will stay low, therefore LNG goes forward which relieves upward price pressure on gas. Focus on other side of the equation if LNG gas projects here go forward. Tells me a lot of dollars think prices stay very low since if they go up projects won't happen.

**Tom Pardee:** The cheaper oil is, the less likely LNG exports are wanted around the world. Can they burn bunker oil? If oil goes high, then more demand for LNG. These are often compared. If oil price is high, there is more demand for LNG exports. That is where LNG comes in. History of LNG is tied to oil so oil price dictates the LNG price. Now the linkage is broken and LNG is not as tied to oil as it was formerly. Now a LNG rate is Henry Hub plus. If oil is expected to go up, then my guess is there'd be more LNG. If oil goes up to \$120 a barrel, a lot more LNG is cheaper.

**Steve Johnson:** One can expect gas to remain flat?

**Tom Pardee:** Yes. Regardless of LNG exports.

**Nikita Bankoti:** What is MSW? *Municipal solid waste.*

**Fred Heutte:** Wonder if you have been following Oregon AR632 docket for Northwest Natural RNG policies?

**Tom Pardee:** Yes, we have had members go to every AR632 rulemaking. We were a part of that. Trying to understand what the policy means. The gas side will have a more detailed overview. I'm not an RNG expert. If you have better information into RNG price on the east side you are always welcome to come over to our TAC.

**Fred Heutte:** Interesting info.

**Jody Morehouse:** Open rulemaking for SB passed 2 weeks ago in Oregon and were adopted 7/31/20. Will cover more in September TAC.

**Nikita Bankoti:** The Commission has an ongoing docket under UG-190818 for the Washington RNG Staff investigation.

**Kathleen Kinney:** Market pricing in the \$10 - \$12 range for RNG is doable. Utility is able to offer a consistent long-term price.

**Kathleen Kinney:** Comments via RNG; for market pricing \$10-12 price is doable. If Utilities can offer a long-term prices that's something that producers are looking for. Another option, I haven't seen done in person is to buy LNG at a relatively low fixed costs until the LNG purchase requirement kick in and be able to sell long term when policies kick in. Avista can take advantage of that margin in the near-term. Again, I'm certainly willing to connect after this.

**Matt Nykiel:** I could use a refresher in terms of how gas impacts customer rates and how that is impacted through the price cost adjustment. How is the price set and passed on if higher or lower?

**Tom Pardee:** Within an LDC. You probably get cheap gas. Projected rate, say it's a dollar comes in higher, then in future rates, we'd charge more. Lower is passed through against rate projection for the future. Pass through at the cost of gas, but procurement charge with no markup. What we buy gas for is what we sell gas to customers for with no mark up. Optimization for Jackson Prairie or transport is for customers and goes against rates. If we sell gas for \$50,000 premium in the market, it goes against rates to offset the commodity rate for overhead. PGA, or purchased gas adjustment is set on November 1<sup>st</sup>. How accurate you were on every November 1<sup>st</sup> is adjusted. If too high now, it reduces rates later. It is an accounting deferral balance.

**Matt Nykiel:** Thanks so much, appreciate the refresher.

### **Natural Gas Price Forecast, Michael Brutocao**

**Ben Otto:** Can you tell us who the consultants are?

**Tom Pardee:** One is Wood-Mackenzie and the other is CERA. They are both well-known and respected within the gas industry. We put out this way so we don't have to get their approval which is difficult.

**Ben Otto:** This highlights our concerns. It is a public process, but having stuff we can't comment on specifically is concerning.

**Dan Kirschner:** Nominal dollars? Yes.

**Nikita Bankoti:** Why is there a difference in percentages used? What is the reason for blending and the mix across the years?

**Michael Brutocao:** Wouldn't want to assume one is more accurate than the other. Significant deviations in NYMEX more than accounts for risk and overtakes what you'd expect the nominal prices to be.

**Nikita Bankoti:** For 2023 weighting, why is NYMEX weighted more than the consultants? Due to standard deviation?

**Tom Pardee:** So for historic measures, NYMEX in the near term is the best indicator of everything that all traders know on that date. Fundamental forecasts take months. NYMEX changes daily and is the most up to date pricing with fundamentals. NYMEX actively trades about three-ish years out – it becomes a lot less liquid the further out you go. Further out is less liquid so you really don't know what the price is the further out you look.

**Steve Johnson:** Can I ask a follow up question? I recall these charts in the past IRPs. Three year forecast based on forwards or combination, then we take consultants with the forwards, update every IRP with the same upward trend further out with the same consultants. I'm not on board as we never seem to see these upward trends. It's the trends I'm not believing in. Will have to drop off in 10 minutes, but will circle back with the team on this topic.

**Sudeshna Pal:** Is there any visibility into the forecast models and discussion into the drivers and what is causing the trends? What are the drivers of this forecast?

**Tom Pardee:** Time. Known elements when putting the forecast together. For example, one forecast may have COVID included, but an older one might not. Individual assumptions and guessing about what may happen and when and how those impact prices. The further out you go, no one is going to be right, but they have people that look at these issues. No one is going to be right.

**Ben Otto:** Past two questions highlights the need to see these assumptions. Customers end up paying for this. Important so we can see and understand. The best practice is to disclose these forecasting techniques to understand them.

**Fred Heutte:** Gas future prices, NYMEX forward strip and the longer term by various consultants. NYMEX market for today is over \$2 at Henry Hub. Really liquid and a good indicator. It is the largest in the world at about \$1 trillion a year, but it doesn't go out far. Starts with 126,000 September contracts, but down to 7,000 by February, and at 18 months almost none. Further out less and less trades yet they report prices all the way out to 2032. Out to 18 months is very good. Longer term forecast basically take the same view – we'll have as much shale gas as we need forever. We don't know the underlying production cost. Prices have been on average over the prices over the last many years. What happens if the industry consolidates? The Wood-Mac and IHS consultants are really smart, doing the best they can. We don't have anything better than long term forecasts. What is the upside price risk – that is the question. Make sure to run a high price gas forecast if that comes to pass which is what the IRP is supposed to address.

**James Gall:** Appreciate the comments on the scenarios we do, which often don't get the focus they deserve. It is important to consider the scenarios from IRP to IRP. There are differences in resource choices. This topic has a lot of interest.

**Nikita Bankoti (slide 9):** Is there a reason there's more gas draws than electric? I believe it is less, but am not 100% sure. What's the reason behind that?

**Tom Pardee:** We do more gas draws because we can. We model on a daily basis. We have a smaller daily model than electric, which is modeled hourly. Ours doesn't take as long to model. One or two days per run, and week on the electric side for one scenario with 500 distribution draws.

**Nikita Bankoti:** OK, that makes sense.

**Kathleen Kinney:** Curious about the higher scenario above the \$10-12 (tying into RNG), is there some way to use extended RNG contracts to take out the risk?

**Tom Pardee:** It is something we can consider because you're definitely taking some of the risk out with RNG. There is a major risk of not being able to get supply. Take risk out of a transportation pipeline. There was the explosion a few years ago on the west side. Cost risk, loss risk and how much RNG can take off the board.

**Kathleen Kinney:** It would have to be a long-term contract.

**Fred Heutte:** Two comments. Run another version of this gas price and market price looking at a peak of \$3 shown. What about a peak of \$4 with consolidation and a lower rig count? With lower supply, prices go up. Delivery risk and questions raised by that.

explosion and compressors. Has Avista looked at the risk involved with your main supply coming down from Alberta, which is very reliable? Have you looked at this risk?

**Tom Pardee:** Yes, we'll talk more about supply risk from major locations at TAC 3. We do look at it and there will be specific sensitivities around this.

**Ben Otto:** 100% or 90% of gas from Canada. Risk should focus on this and not necessarily on the hubs since all supply comes from Canada. Previously you've shown you only use Canadian supply.

**Tom Pardee:** We do use the other supply areas, although not as much. Where we have supply from is number 1 at AECO, number 2 at Sumas for peak and Jackson Prairie, and number 3 from Rockies for peak and Oregon. Each of these we look at to restrict or take out of the model to understand. In the overall portfolio, Rockies in about 1-in-10 situations.

### **Upstream Natural Gas Emissions, Tom Pardee**

**Tom Pardee:** Upstream emissions are natural gas emissions that occur prior to the point of combustion.

**Mike Morrison:** When computing Global Warming Potentials, what were the residence times assumed for each gas? How long are they assumed to remain in the atmosphere?

**Tom Pardee:** 1 element of carbon, 1 factor of CH<sub>4</sub> equal to 34. Continues to grow (NO<sub>x</sub>) in the 100 year potential.

**Kathleen Kinney:** CH<sub>4</sub> degrades to CO<sub>2</sub> near-term emission and decreases as it degrades over time.

**Fred Heutte:** I'm certainly not an atmospheric chemist. CO<sub>2</sub> not very interactive whereas methane is very interactive. For CO<sub>2</sub>, half is taken up in a year into trees, ocean, and vegetation and the rest is over 1,000 years – impact is long. Methane – because it's interactive – it's in the atmosphere for 10-12 years and gone in 20.

**Nikita Bankoti:** Is this a recent EP estimate?

**Tom Pardee:** 2020.

**Dan Kirschner:** April 2020 – considers through 2018.

**[8/6/2020 12:44 PM] Steven Simmons:** <https://www.nwcouncil.org/energy/energy-advisory-committees/natural-gas-advisory-committee>  
(<https%3a//www.nwcouncil.org/energy/energy-advisory-committees/natural-gas-advisory-committee>) link to Northwest Power & Conservation Council work on methane & NGAC



**Fred Heutte:** We will be submitting comments in writing to Avista on this topic and won't belabor the point here. We are concerned with the emissions factor in the US and Canada. The EDF project has been working on this issue for better than a decade. Scientists and analysts in the US, the council adopting their low emissions rate in the US. The problem with the Canadian sources is they are based on old data. Recent publications in peer reviewed journals will show this. Reasonable data for US-sourced gas, but not Canadian-sourced gas which hasn't been updated.

**Dan Kirshner:** We have a bit of a different perspective than Fred and will provide our comments to the council. We support the regional approach Avista is taking as opposed to national averages. Puget Sound Clean Air Agency and the Port of Kalama data are government sponsored and is sufficient and a good approach for Canada. We disagree with NWECC for the Rockies. EPA has an annual update for Rockies. Each year is appropriate in that regard. Will send a letter regarding this. There are different perspectives on this.

**Tom Pardee:** Thanks Fred and Dan. The problem is Avista is not an expert on this upstream emissions issue, but we have some expertise.

**Fred Heutte:** We're not experts. Canadian FIMSA (0.78). It's like pricing. You do as best as you can. Appreciate there's different perspectives. Power Council – we feel this is the appropriate factors.

**[8/6/2020 12:49 PM] Vlad Gutman-Britten:** It would be useful to include at minimum a sensitivity with a higher leakage rate to understand the impact of that choice on resource selection.

**Tom Pardee:** We could do this as Dan mentioned to show sensitivity. If we were to use 2.3% for Rockies, it doesn't impact much because of how little gas we have from there. Scenarios will likely address some of this. One scenario will be to change this fraction.

**[8/6/2020 12:50 PM] Vlad Gutman-Britten:** For example using EDF's number. Yes. That would allow stakeholders to evaluate how important/not important this factor is. Thanks very much for your consideration.

**[8/6/2020 12:52 PM] Ben Otto, ICL:** Agree with Vlad. For any uncertain forecast it is good practice to assess a range of scenarios.

**Fred Heutte:** Some Canadian numbers are really dated and minor updates in the last 20 years.

### **Regional Energy Policy Update, John Lyons**

Investment and production tax incentives:

PTC \$15/MWh (base) for 20 years for wind started by 12/31/20

ITC for solar drops 30% in 2019, 26% in 2020, 22% in 2021, 10% from 2022 on

ITC for battery storage if filled with solar

**[8/6/2020 12:57 PM] Vlad Gutman-Britten:** On the incentive side, are you considering Washington state sales/use tax incentives for RE sited in the state?

**James Gall:** Yes we include those incentives in our Generating Resource Assumptions sheet.

**[8/6/2020 12:58 PM] Snyder, Jennifer (UTC):** I thought New Mexico passed a clean energy law. Am I mistaken?

**Vlad Gutman-Britten:** Yes.

**Fred Heutte:** Will put a link in the chat re: modeling this in Aurora from yesterday's NPPCC meeting. Here's the NW Council presentation and the spreadsheet. These are downloads from the Box file sharing service:

- <https://nwcouncil.app.box.com/s/s2whne2t77a1qxpm17qtz5aorwuksjil>
- <https%3a//nwcouncil.app.box.com/s/s2whne2t77a1qxpm17qtz5aorwuksjil>
- <https://nwcouncil.app.box.com/s/po27u2275z0cuanuix6oucncw7luz62bk>
- <https%3a//nwcouncil.app.box.com/s/po27u2275z0cuanuix6oucncw7luz62bk>

**[8/6/2020 1:03 PM] Fred Heutte (NVEC):** And the System Analysis Advisory Committee web page is here: <https://www.nwcouncil.org/meeting/system-analysis-advisory-committee-webinar-august-5-2020>  
<https%3a//www.nwcouncil.org/meeting/system-analysis-advisory-committee-webinar-august-5-2020>)

**Ben Otto:** Back to tax credits slide. PTC could be charged to storage if charged with renewable. For this IRP will there be basic market power storage and renewable.

**James Gall:** We modeled both and treated the PTC correctly. Both technologies were selected. One bundled with storage and selected. Storage as a standalone resource with the credit. Both were selected.

**[8/6/2020 1:05 PM] Rachelle Farnsworth:** What happens to costs above 2%, and costs for Colstrip that could occur after 2025?

**James Gall:** Colstrip costs from a CETA perspective. The 2% cost gap not applicable to Colstrip since it'll be fully depreciated by 2025

**Vlad Gutman-Britten:** I don't believe the statute says for "new" resources. Can you explain your interpretation?

**James Gall:** Two instances 1) you're correct, 2) for new resource decision-making.

**Matt Nykiel:** Can you talk more about how the social cost of carbon was analyzed – fixed or variable cost?

**James Gall:** Planning on modeling social cost of carbon similarly to the expected case in the last IRP. Model plant's dispatch of real-time operations – new resources would include construction and operations costs of emissions (shared at last TAC meeting). Will be included in the optimization used to determine the least cost options. DR will be assigned an emission benefit. Scenarios will be run for the Idaho portion to understand the social cost of carbon implications for Idaho customers.

**Nikita Bankoti:** The Commission needs to update the social cost of carbon costs, it should be updated and on the website [WUTC] soon.

**Matt Nykiel:** Is Avista treating SCC as a fixed or variable cost.

**James Gall:** Variable. There's a price that's fixed (construction) but also variable cost assigned to operations.

**Matt Nykiel:** Can you clarify “analyzing social cost of carbon for Idaho”, clarify the difference. I'm not totally taking up what you are putting down for Idaho.

**James Gall:** The social cost of carbon is included for Washington as required by law. Scenarios for that cost for Idaho. Will discuss at next electric TAC. For the variable cost, the price [per metric ton] of the social cost of carbon is fixed for each year, but the total cost is variable each year with the amount of emissions plus the emissions from construction. For Washington, it is in the expected or base case and as a scenario for Idaho.

**[8/6/2020 1:12 PM] Fred Heutte (NVEC):** Clarification from Joni: Hi all, Joni asked me to pass this along (she can add more via the phone): the 2045 standard is for non-emitting and RE.

Sec. 5. (1) It is the policy of the state that nonemitting electric generation and electricity from renewable resources supply one hundred percent of all sales of electricity to Washington retail electric customers by January 1, 2045. By January 1, 2045, and each year thereafter, each electric utility must demonstrate its compliance with this standard using a combination of nonemitting electric generation and electricity from renewable resources.

### **Natural Gas and Electric Coordinated Study, James Gall and Tom Pardee**

**James Gall:** Potential scenarios – it would be helpful to have input on these; are these the right scenarios to look at?

**Fred Heutte:** Heating and cooling, are you also looking at water heating?

**James Gall:** Yes, we will get to that in a minute.

**Kathleen Kinney:** On the 10% efficiency, can you explain that more, is that a benefit to electricity?

**James Gall:** We're making assumptions of how folks will convert. We're reducing conversions by 10% in case we missed some efficiency benefits. More biased to electric.

**Fred Heutte:** Have you been following Power Council and their load forecast? Are you looking at a climate adjustment to the forecast for the substantial increase in late summer demand?

**James Gall:** Yes. That is a great question for the next meeting, it will probably be a topic at the next TAC.

**Fred Heutte:** Detecting a theme – lots of interesting stuff at the next meeting.

**Kathleen Kinney:** What portion are you assuming are heat pumps (of converted)?

**James Gall:** Most gas to electric is to heat pumps.

**Kathleen Kinney:** Is there a lower efficiency scenario too? Not everyone is going to convert to heat pumps.

**James Gall:** A lot of that can be derived from showing the efficiencies at various temps.

**Dan Kirschner:** Baseboards are 100% efficient at site. Are you assuming at site?

**James Gall:** This is at the site. When building generation, we'll have to adjust for losses.

**Jennifer Snyder:** Baseboard versus heat pump idea, if someone were thinking of going from gas to electric, most people wouldn't go from gas to baseboard.

**James Gall:** Conversions currently using furnaces are often ducted or point source heat. Homes with ducts will likely convert to heat pump. Those using point sources will use a mix and it's tough to determine the mix of baseboard to heat pumps.

**Nikita Bankoti:** Very drastic change in period, more energy use at peak, you'll be using a lot of different resources, will customers be charged a higher rate?

**James Gall:** Because of added load in the winter, what is the impact to customers? The IRP process will illustrate the cost impact as compared with the expected changes and also look at what the customer is avoiding on the gas side. Please look at the last IRP where we did a similar analysis. Cost is higher, emissions are lower. Will the customer be paying more? Will depend on price of power, environmental policies, and conversion costs (customer-borne). Lastly, we also need to address impacts on T&D – large conversion to electric will likely require T&D incremental infrastructure costs. We may not be able to address that in this IRP.

**Vlad Gutman-Britten:** Sorry, missed the first chunk of that. The idea of extra load needs to be served with long-duration storages. CCS and RNG that can fill in that role

Studies show that you can fill in the role without long-term storage. Are you looking at space and water heating?

**James Gall:** Looking at all end uses – water, space, process.

**Vlad Gutman-Britten:** In calculating peak are you incorporating latest codes?

**James Gall:** Yes we're trying to estimate what the peak is, then when we pick resources, the type of program that would reduce peak if cost effective.

**Vlad Gutman-Britten:** Incorporating that type of resource? Yes.

**Jennifer Snyder:** Are you modifying this within the CPA's technology potential?

**James Gall:** Yes, since increasing the amount of water heaters on the system.

**Kathleen Kinney:** Could it be looked at with a cost comparison using RNG to achieve the same emissions goal?

**James Gall:** Yes. Tom will have scenarios. My side will show electric and comparing both we can come to a conclusion. Advantage of gas/electric IRP at the same time – we can look at both.

**Fred Heutte:** Glad water heater load management is already addressed. With new cross sector load on the section including electrification, if that load can be managed, it should be. To what degree have you looked at managing space heat?

**James Gall:** Through the CPA. Look at manageable savings we can get from our existing load and how does that apply to this situation.

**Ben Otto:** Along with DR, applies to space heating load, applying a package of building shell improvements is another way to address this issue.

**James Gall:** We will look to AEG for this and work with the CPA to incorporate.

**Jennifer Snyder:** Depending on how much you can do this in your CPA, electric house has ability to be made tighter than gas heated house. Don't know if that will make a difference or if it can be captured in a CPA. Will have to get back to the group on this.

**Kathleen Kinney (slide 15):** I'm confused, I'm looking at the graph and it looks like higher is more efficient.

**James Gall:** Less efficient the higher you go on the Y axis. More kWh used per Dth replaced.

**Sudeshna Pal:** What is the current technology?

**James Gall:** Slides 6-7, the Base Case we already shared using current technology to estimate future loads using more efficient technology in the future. Hybrid uses gas and electricity more efficiently with existing technology.

**[8/6/2020 2:24 PM] Vlad Gutman-Britten:** I think we'll have comments on some of the end use efficiency assumptions, but will provide those in writing.

**Mike Morrison (Slide 15):** Dth to kWh is about 293, so what you are saying is the hybrid future is 6 times as efficient?

**James Gall:** That is not what this is showing at the amount of gas in the base scenario. We're using electric not gas. Trying to illustrate how much gas demand will go to electric. This may not be the best way to show that. We start with this track, but converting with simplifying, we remove space heat from the calculation. Efficiency components are multiplied to those end uses.

**Mike Morrison:** Ok, so this is only in the context of the conversion you are doing. It seems very complicated, you might have done it a simpler way.

**[8/6/2020 2:28 PM] Steven Simmons:** Have you thought about what might be the implications on the gas system in these scenarios - especially the hybrid system where you are relying on gas solely for peak days. More gas storage?

**Tom Pardee:** Will come out in the scenarios; maybe RNG can take some of this risk off the system. Will circle back to the electric TAC to show the results of modeling this on both sides.

**Highly Impacted & Vulnerable Populations Baseline Analysis, James Gall:**

**Nikita Bankoti:** Interesting to understand if company will use a map or delve into individual household data. Interesting that resources are in these neighborhoods. What does the company plan to do in this area regarding equity and community engagement? Are you considering any factors and pollution burden for these indicators?

**James Gall:** At this time, we haven't looked at those two items yet because it's outside of the law. The expectation is areas may be added, but we didn't want to go down that path until we get an indication from the state regarding these areas. May have low income in areas that aren't necessarily impacted. We have low income programs broader than these areas. Look at how the law is written – what these areas look like today versus the future. That's where we're focusing right now. Looking to include these populations in future IRPs as well as maybe programs to address these areas. There are limited things an IRP can do. Where does the IRP apply and where do other processes apply?

**[8/6/2020 2:47 PM] Vlad Gutman-Bittmen:** Given that the statute emphasizes health, I assume you mean locating non-emitting assets in identified communities? Just a note that not all resources that are "clean" under CETA are clean from a health perspective, like biomass for example, but understand your point. Thank you.

**James Gall:** Correct.

**Max St. Brown:** Lot of overlap with what we're doing for COVID and what customers are being impacted. Is this process of linking marketing data to customer data being documented?

**James Gall:** No we ended up using census data for the most part and not the marketing data.

**Lori Hermanson:** Trove purchases data from 27 different parties and compiled income data. We ended up using census data because the data was substantially different.

**Nikita Bankoti:** If you have data on average household size, can that be used?

**Grant Forsyth:** Yes there's average household size from the American Community Survey. It doesn't go very far back, seems to be volatile and has been smoothed so much it has little variation over time. It is somewhat difficult data to work with unless you use a 5-year moving average. You can get it down to the tract or block level, but can you do any time analysis? 3 – 5 year average smooths things out a bit and causes problems.

**[8/6/2020 3:00 PM] Griffith, Kate (UTC):** Are you able to see how this changes in summer or winter months?

**James Gall:** No, only annual data is available. Will probably be a future analysis to see from a heating versus air conditioning point of view.

**Nikita Bankoti:** Not a question. Just thinking if it will be easier to access and analyze population density data (in vulnerable areas) instead of household level data.

**Vlad Gutman-Britten:** Is the reason for the shorter outage in vulnerable areas because they're urban?

**James Gall:** Yes, more vulnerable populations are in suburban areas. Being in the mixed vulnerable and not vulnerable areas takes more time driving to them to fix the outage.

**Vlad Gutman-Britten:** Not being accusatory, but it is not accurate to say vulnerable areas are receiving a more resilient service because it is just in an urban area that is easier to service?

**James Gall:** Wouldn't go that far yet. The only ones that are less are rural areas. These are very rural areas and if the analysis is by customers per mile this may be the case. It would require more analysis and this may be the next step. Vulnerable areas seems to have more reliability in urban areas.

**[8/6/2020 3:14 PM] Vlad Gutman-Britten:** Controlling resilience for customer density does seem like a useful metric to develop to identify discrepancies. If they exist.

**[8/6/2020 3:15 PM] Vlad Gutman-Britten:** Will you resend the deck with new slides please?

**[8/6/2020 3:15 PM]** Yes, we will. Either later this week or early next at the latest.

**[8/6/2020 3:18 PM] Ben Otto, ICL:** Rathdrum gas power plant in Idaho is very close to the Washington border. Is this included?

**James Gall:** No, it is not included in this study being it's in Idaho.

**[8/6/2020 3:19 PM] Vlad Gutman-Britten:** I'm assuming this is assuming that pollution harms accrue near a facility? This isn't based on a pollution transport model? What about identified community down-wind even if they're not close to a facility.

**James Gall:** Haven't gotten down to that level. CS<sub>2</sub> in Oregon and several CCCTs, Rathdrum, Colstrip, etc. and limited thermal generation in eastern Washington. This is really only what there is in Washington.

**Fred Heutte:** Not that I'm an expert, but there is a good study on this from Portland State. When you look forward to where the EV infrastructure can be placed, this is something we should consider forward-looking.

**[8/6/2020 3:24 PM] Vlad Gutman-Britten:** These strike me as good metrics, but I'm not sure the folks on the phone are necessarily well positioned to answer. That may require proactive outreach to groups active in some of the communities you identified, as well as Front & Centered.

**Fred Heutte:** CIMS or other data. Make sure to note where the data is coming from for these studies.

**Ben Otto:** Super fascinating. Really good work. We'd encourage Avista to apply the same thinking to Idaho. Just the right thing to do. Aligns with your corporate commitments.

**Vlad Gutman-Britten:** Agree, its great work.

**Ben Otto:** This presentation has helped me understand the right questions to ask.

**Nicholas:** The OPUC breakout is by area (block group) of the vulnerable population. One point of verification. Understand it as break out by area as being broadly, rather than by meter.

**James Gall:** Characterized by geography. Meters in an area, but not identified if a particular customer or not. Not necessarily every customer in that area is vulnerable. Remind ourselves not to focus on geography when developing programs.



**Nicholas:** Right. Thank you. Wanted to make sure. It is a challenge.



# Economic, Load, and Customer Forecasts

Grant D. Forsyth, Ph.D.  
Chief Economist  
Technical Advisory Committee Meeting  
August 18, 2020

# Main Topic Areas

- **Service Area Economy**
- **Long-run Energy Forecast**
- **Peak Load Forecast**
- **Long-run Gas Customer Forecast**





# Service Area Economy

**Grant D. Forsyth, Ph.D.**  
**Chief Economist**  
**[Grant.Forsyth@avistacorp.com](mailto:Grant.Forsyth@avistacorp.com)**

# Distribution of Employment, 2019

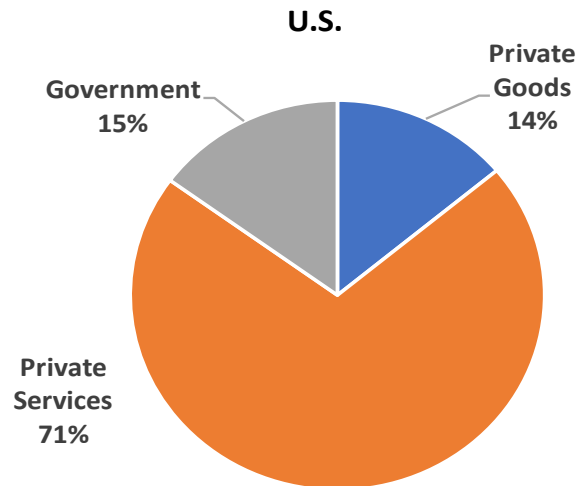
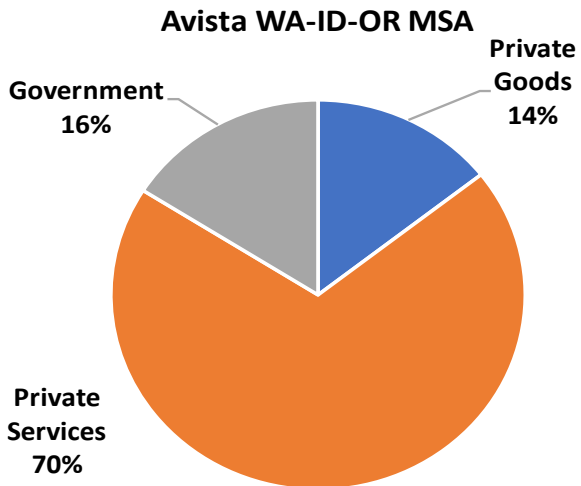

**Avista WA-ID-OR MSA Government**

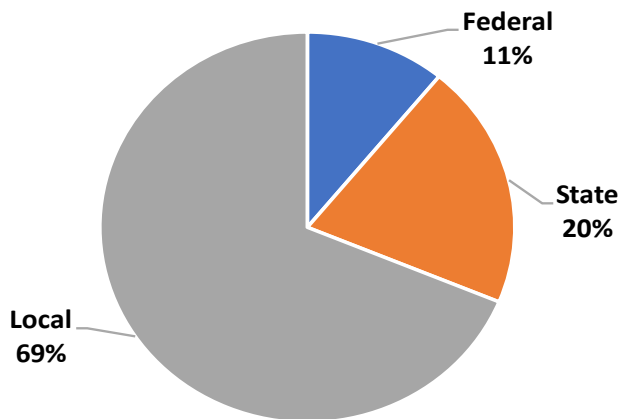

**U.S. Government**

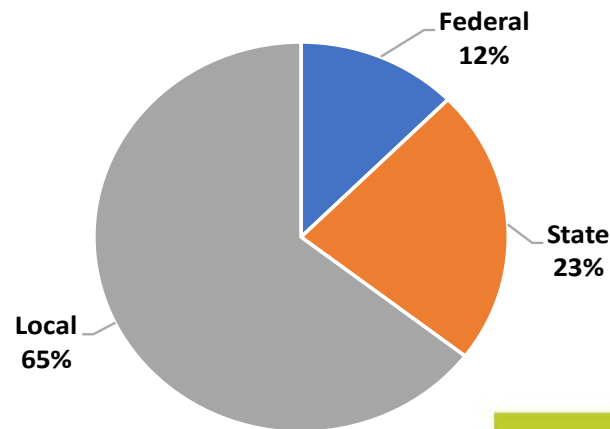

# Non-Farm Employment Growth, 2009-2020

Non-Farm Employment Growth (Dashed Shaded Box = Recession Period)

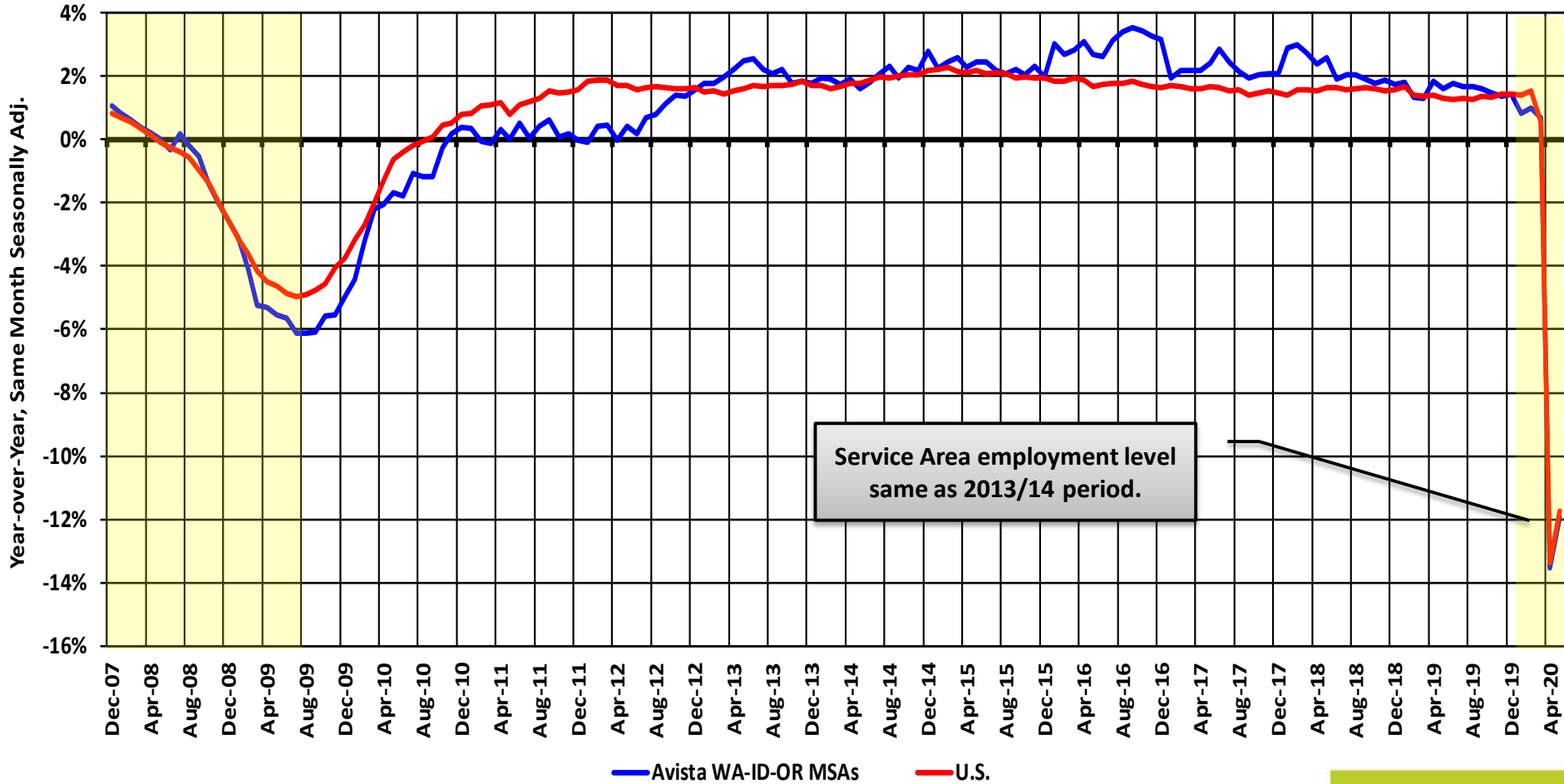

# MSA Population Growth, 2007-2019

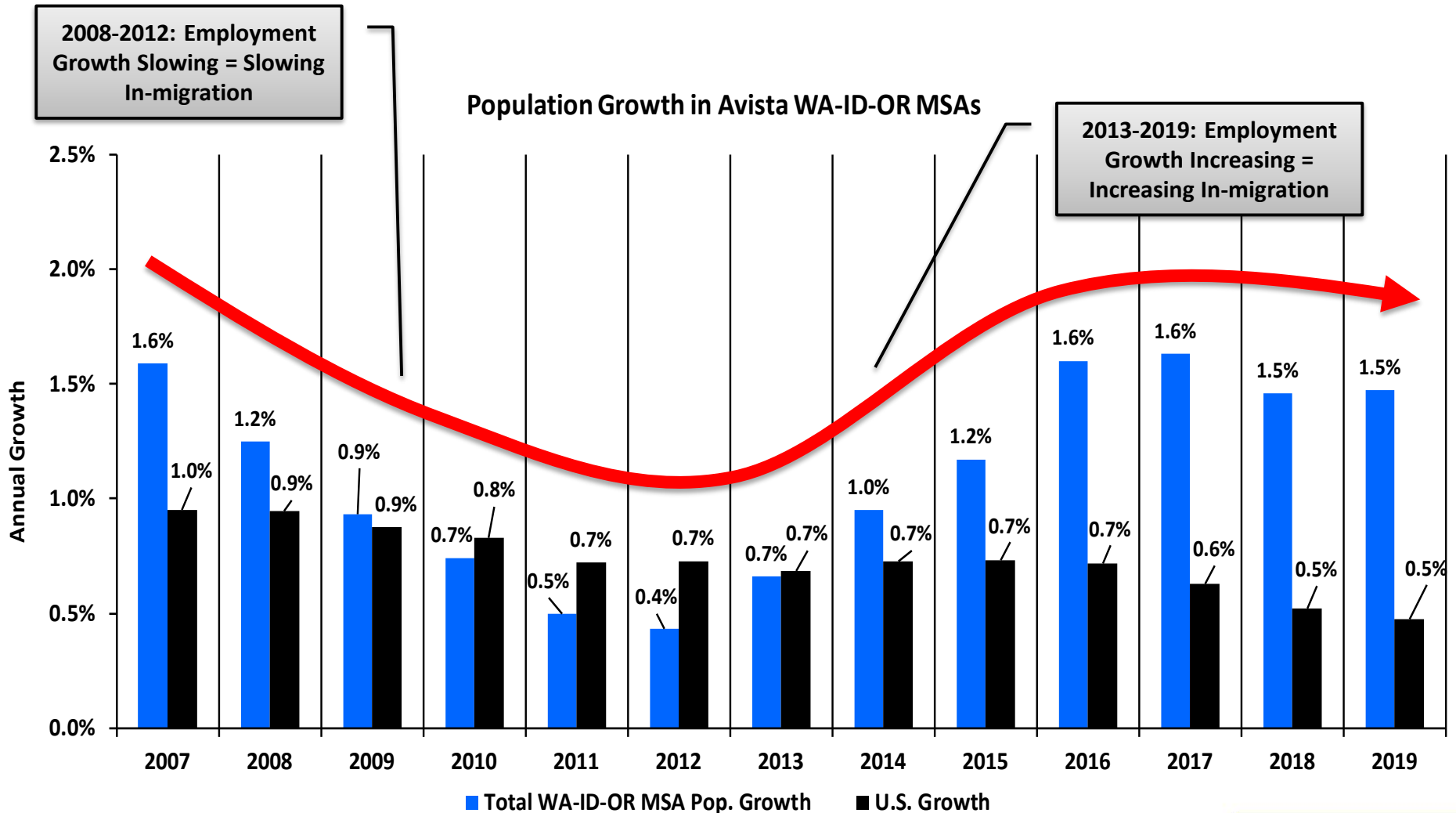

# GDP Growth Assumptions: 2021 IRP vs. 2020 IRP

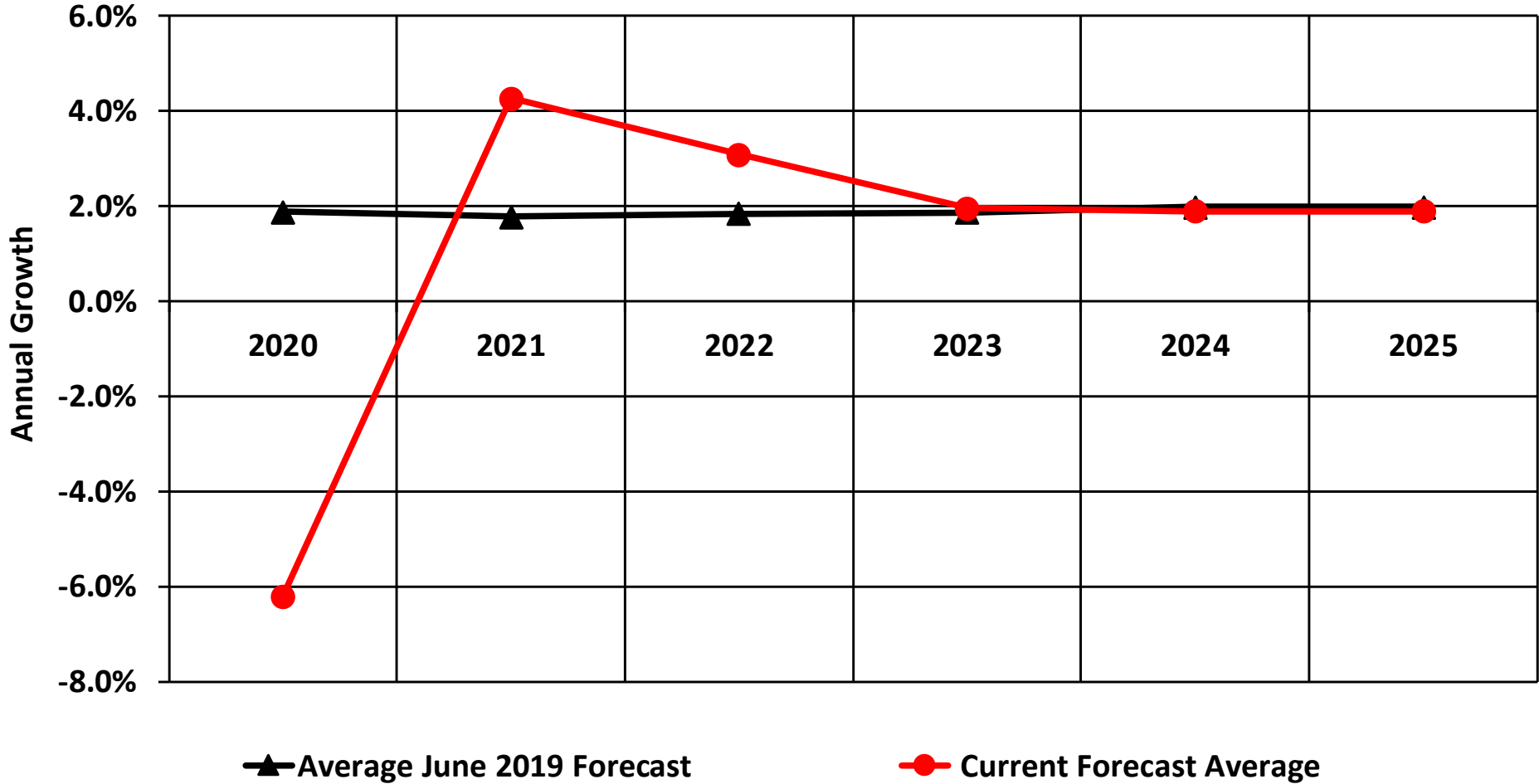





# Long-Term Energy Load Forecast

Grant D. Forsyth, Ph.D.  
Chief Economist  
Grant.Forsyth@avistacorp.com

# Basic Forecast Approach

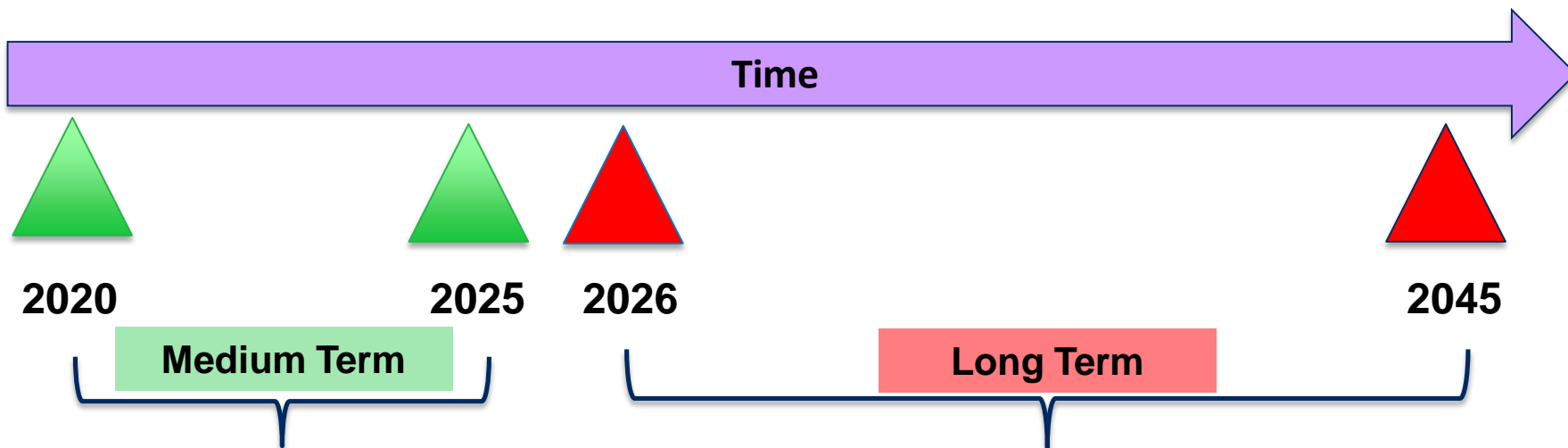

- 1) Monthly econometric model by schedule for each class.
- 2) Customer and UPC forecasts.
- 3) 20-year moving average for “normal weather.”
- 4) Economic drivers: GDP, industrial production, employment growth, population, price, natural gas penetration, and ARIMA error correction.
- 5) Native load (energy) forecast derived from retail load forecast.
- 6) Current forecast is the “Summer/Fall Forecast” done in June.

Avista Corp.

- 1) Boot strap off medium term forecast.
- 2) Apply long-run load growth relationships to develop simulation model for high/low scenarios.
- 3) Include different scenarios for renewable penetration with controls for price elasticity, EV/PHEVs, and natural gas penetration.

# The Long-Term Relationship, 2021-2045

Load = Customers X Use Per Customer (UPC)

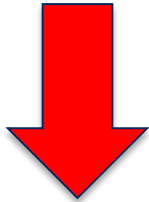

Load Growth  $\approx$  Customer Growth + UPC Growth

Assumed to be same as population growth for residential after 2025, commercial growth will follow residential, and slow decline in industrial.

Assumed to be a function of multiple factors including renewable penetration, gas penetration, and EVs/PHEVs.

# Residential Customer Growth, 2020-2045

Annual Residential Customer Growth Rates

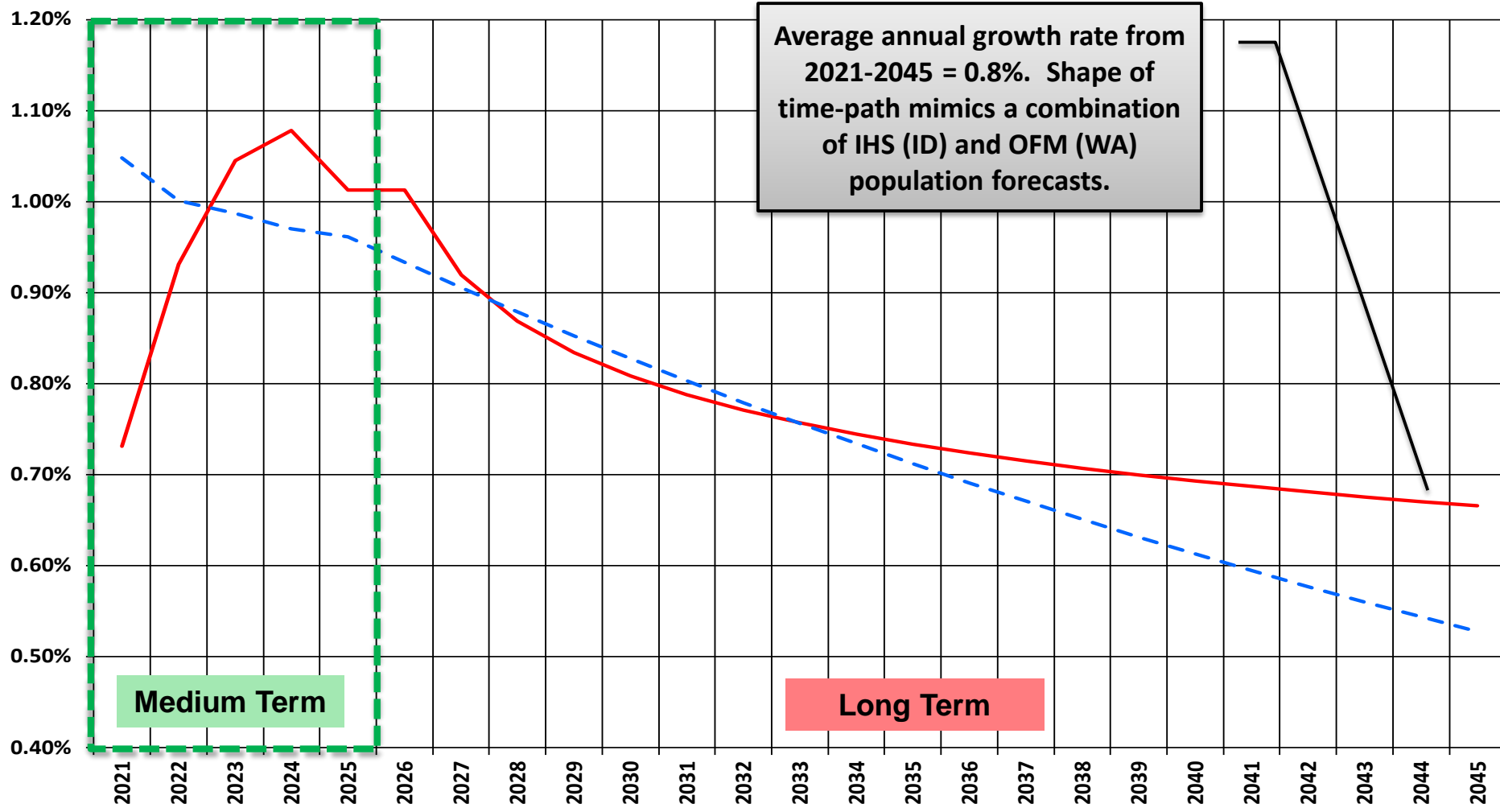

# Residential Solar Penetration, 2008-2019

Customer Penetration vs. Customers Since 2008

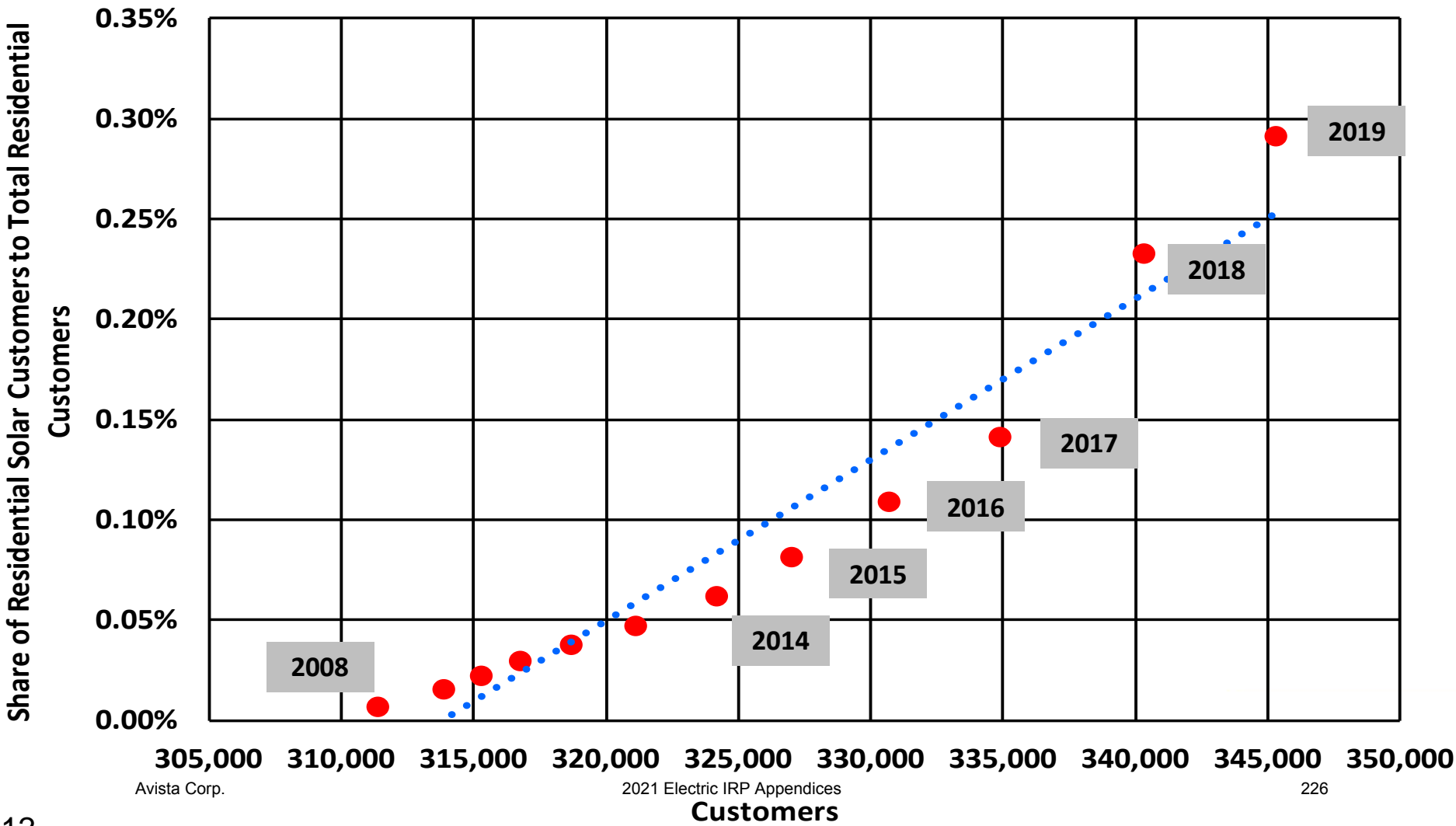

# Residential Solar Penetration, 2021-2045

Projected Base-Line Residential Solar Customers

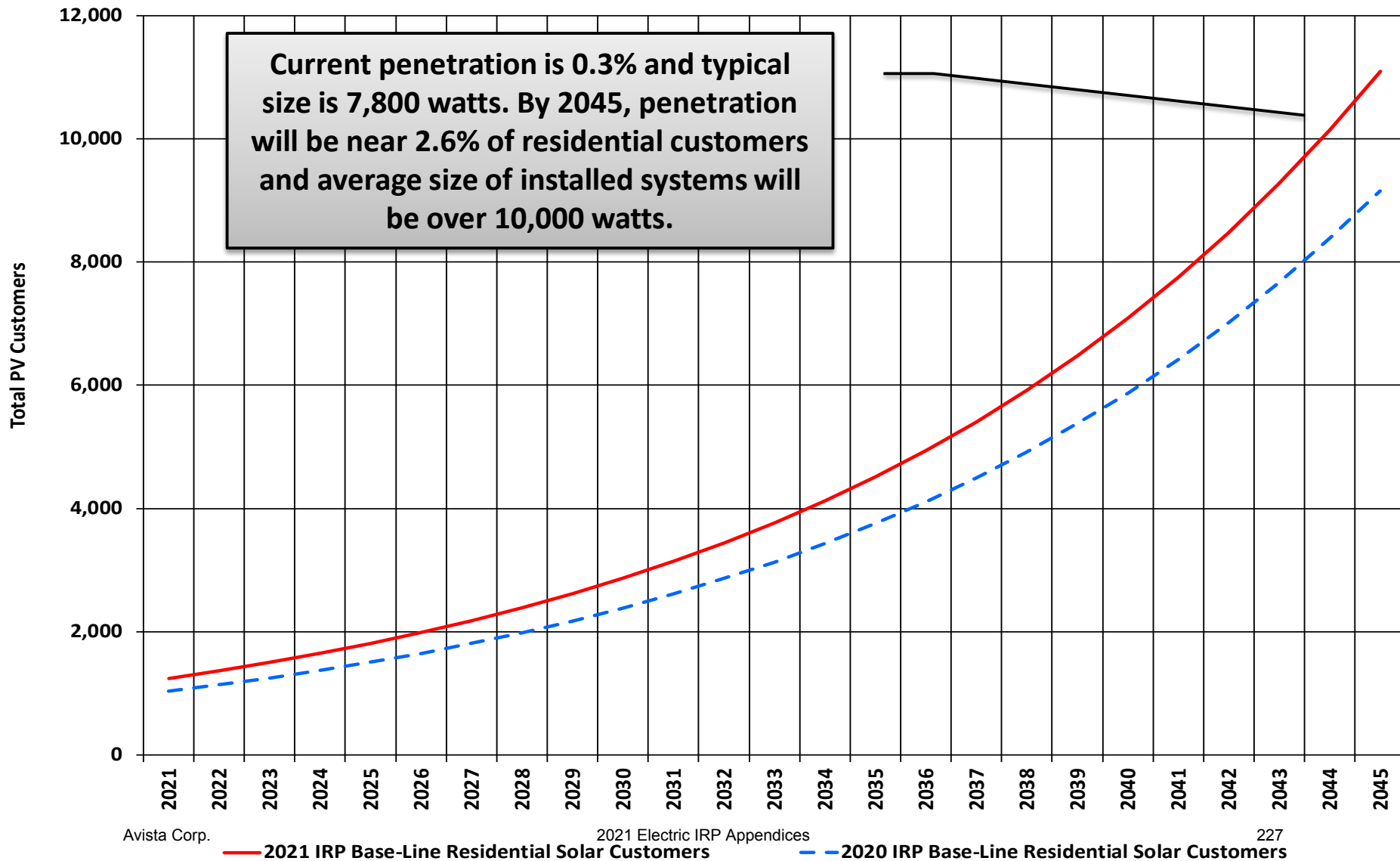

# Residential EVs/PHEVs, 2021-2045

Projected Residential EVs/PHEVs

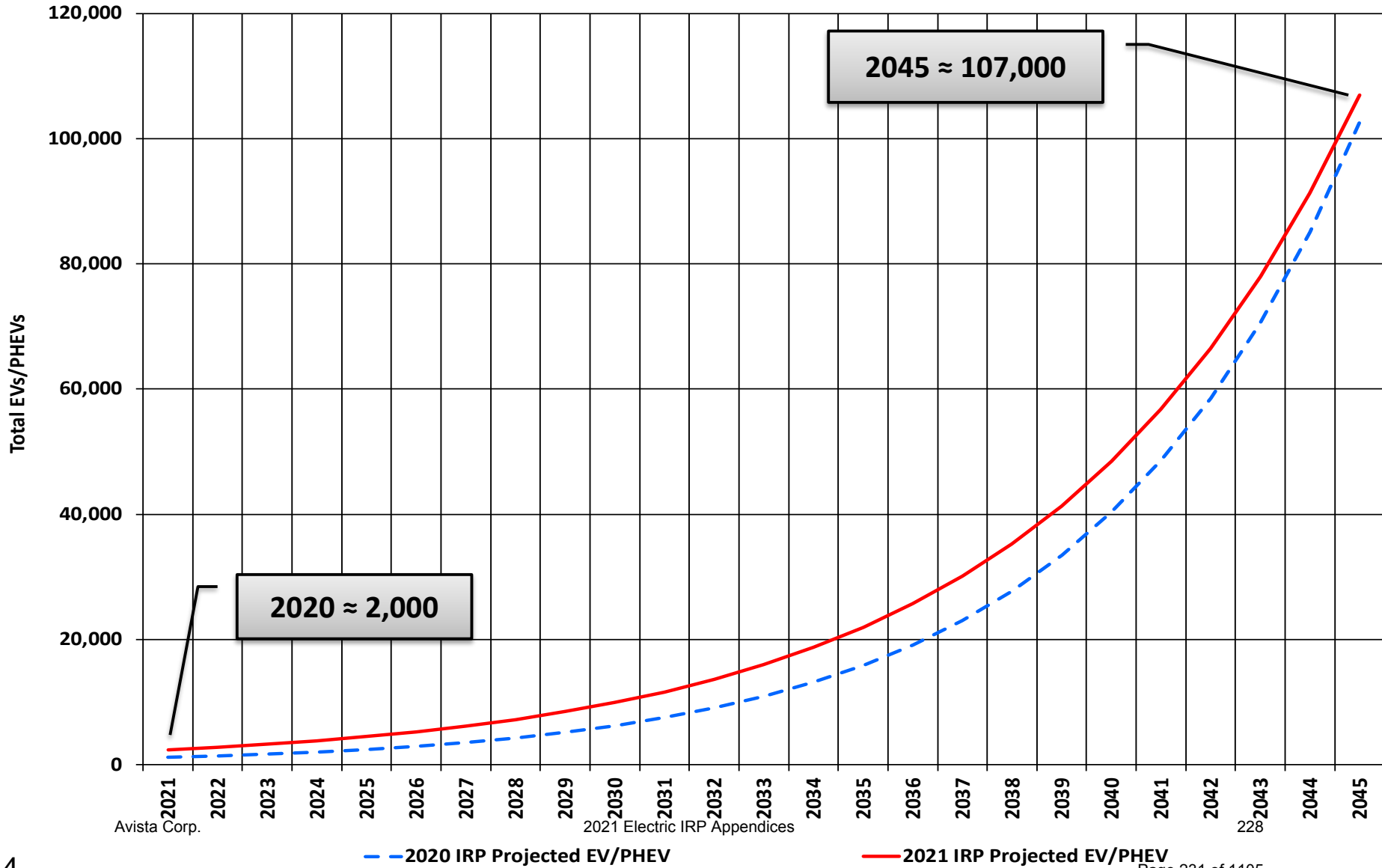

# Net Solar and EV/PHEV Impact, 2021-2045

Average Megawatt Impact of Solar and EV/PHEV

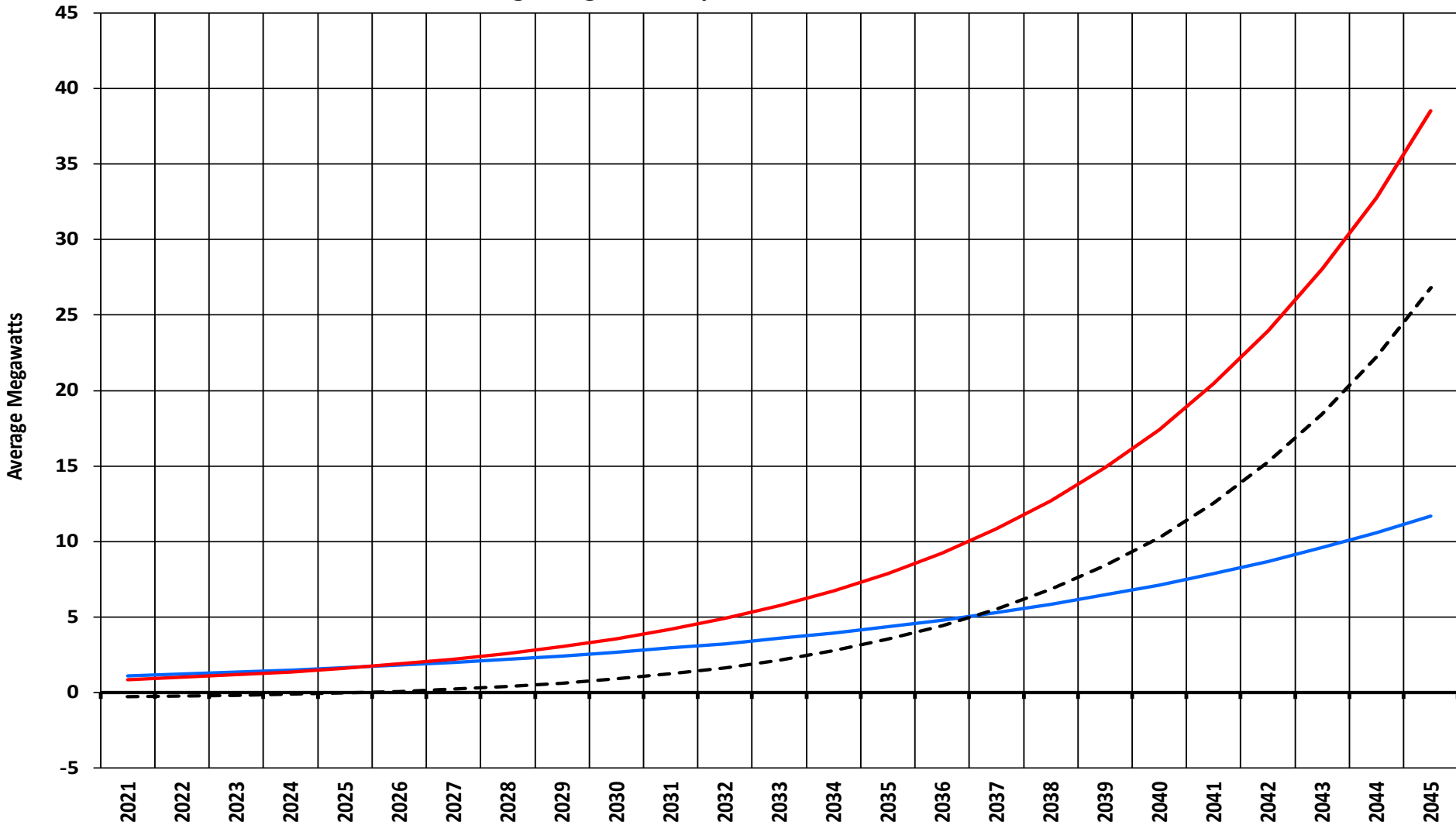



# Native Load Forecast, 2021-2045

IRP	Avg. Annual Growth
2020 IRP	0.3%
2021 IRP	0.3%

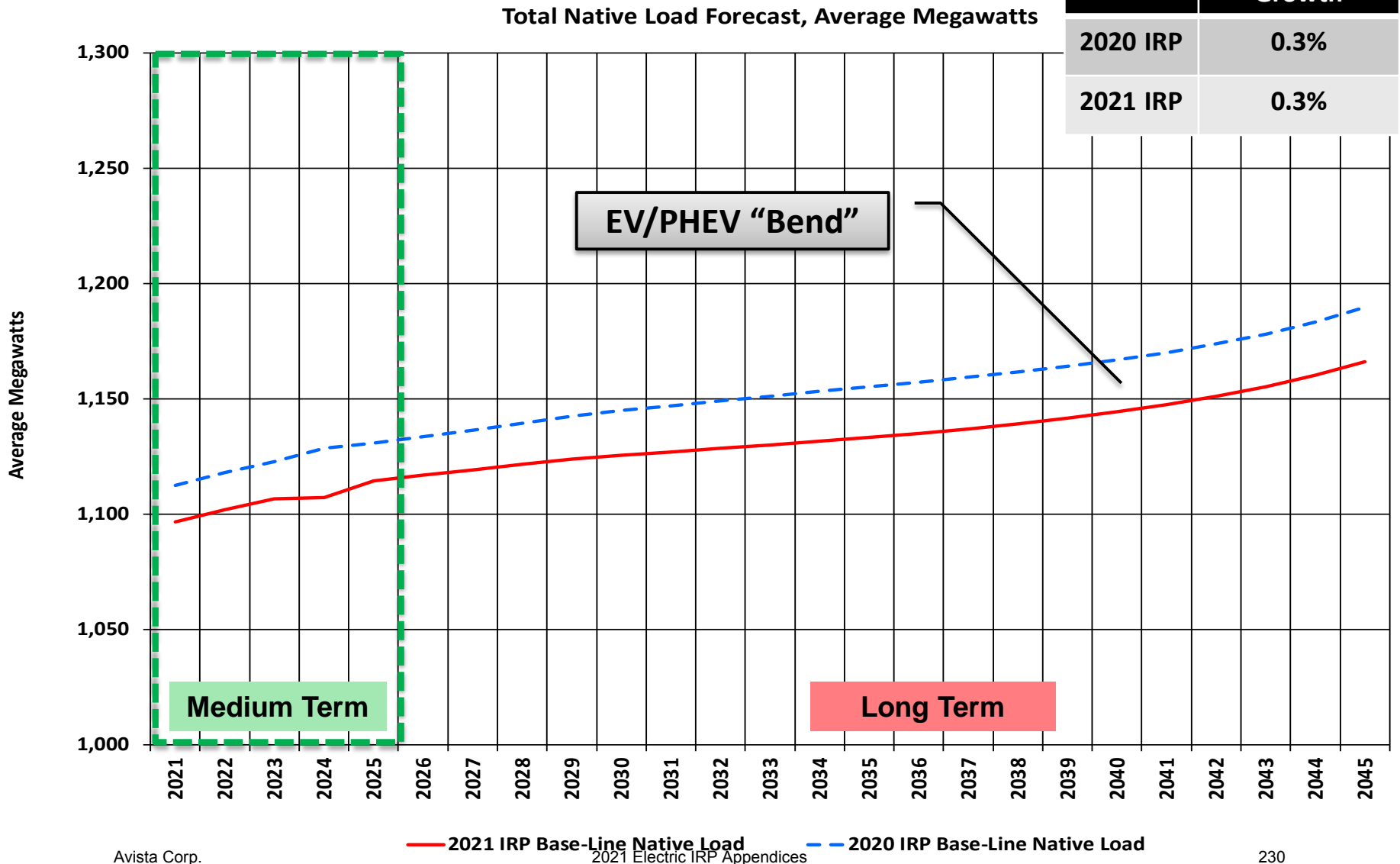

# Climate Change: A Trended 20-year Moving Average (Preliminary!)

### 20-yr MA CDD

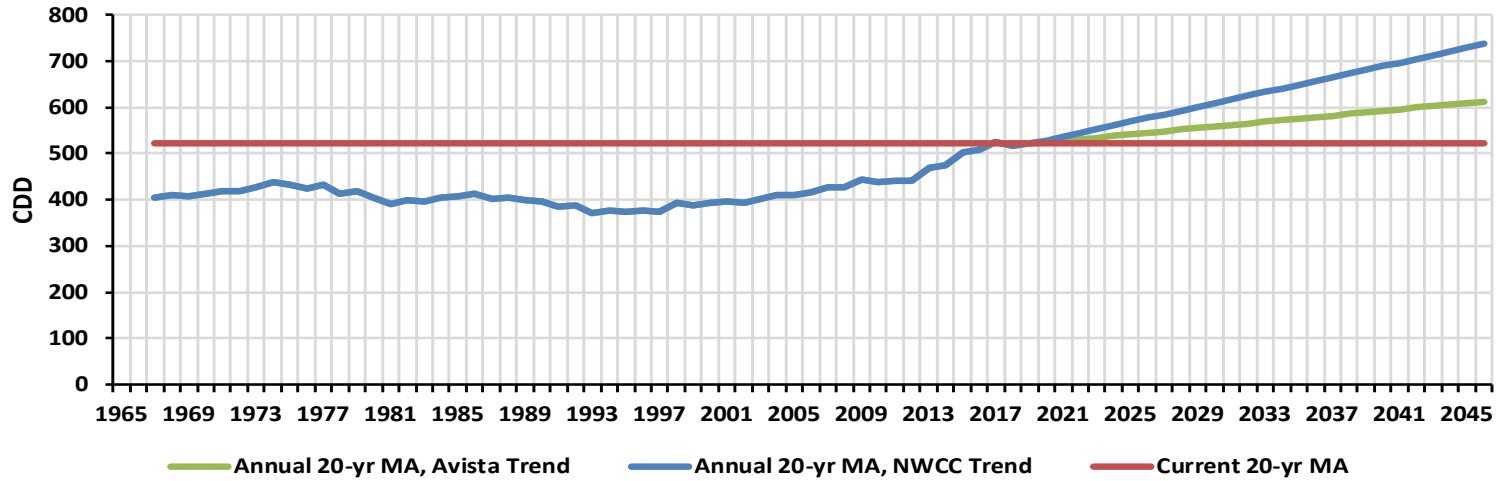

### 20-yr MA HDD

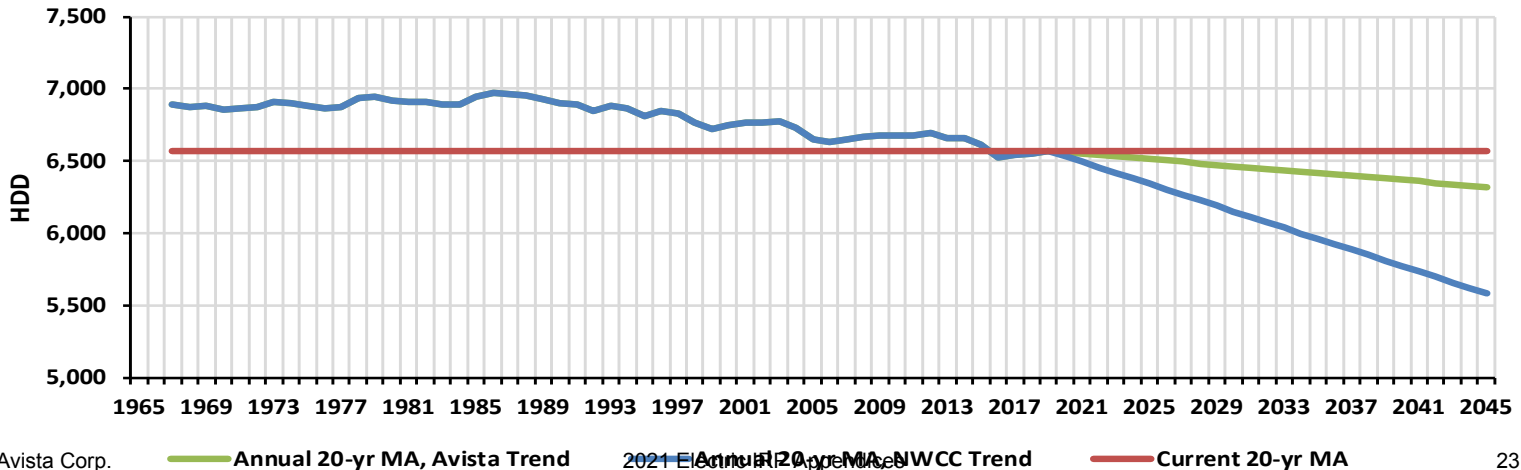

# Annual Native Load Forecast with Climate Change, 2026-2045 (Preliminary!)

IRP	Avg. Annual Growth
2021 IRP, No Trend Base-Line	0.23%
2021 IRP, NWCC Trend	0.13%
2021 IRP, Avista Trend	0.21%

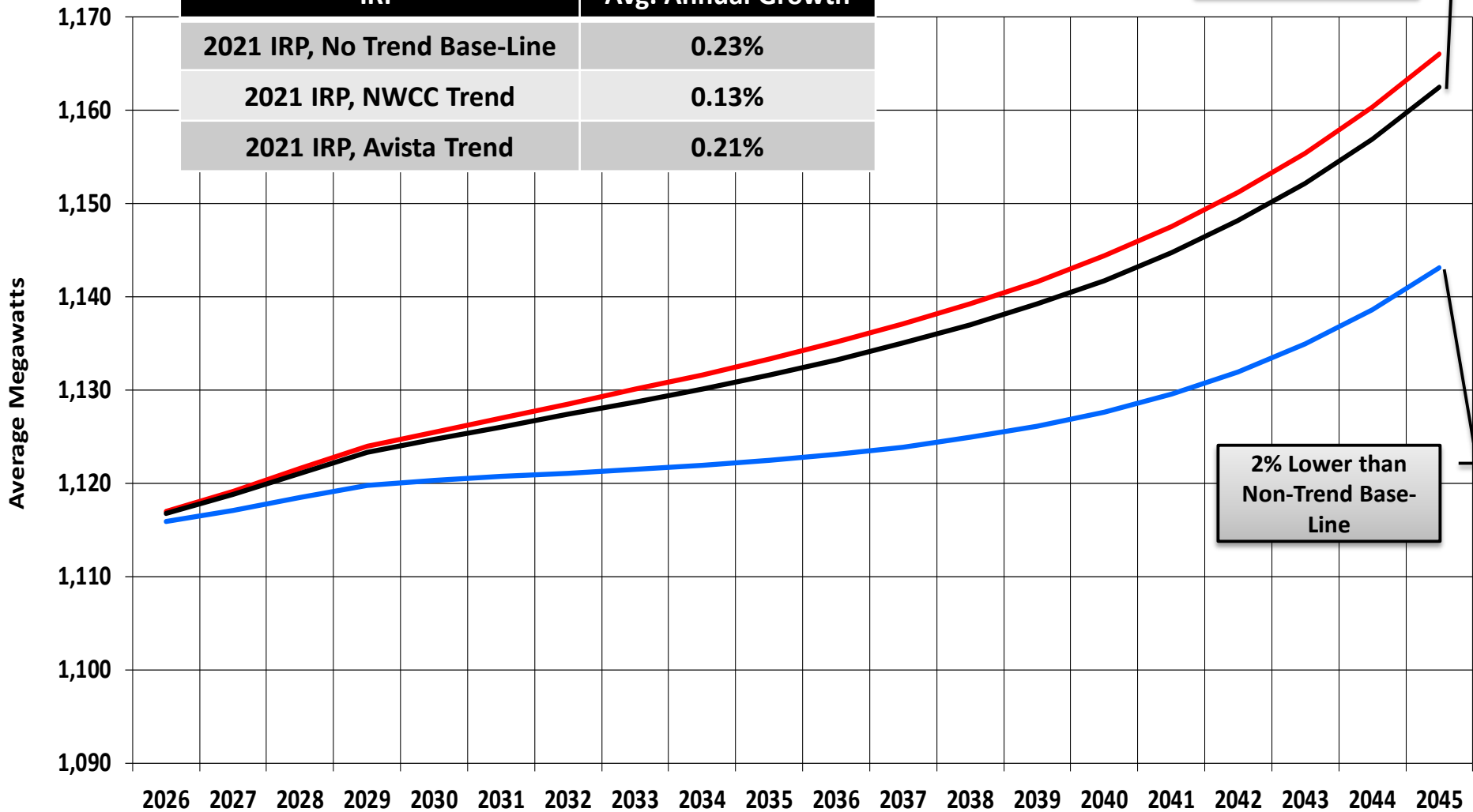

0.3% Lower than Non-Trend Base-Line

2% Lower than Non-Trend Base-Line

# Native Load Growth Forecast, 2021-2045

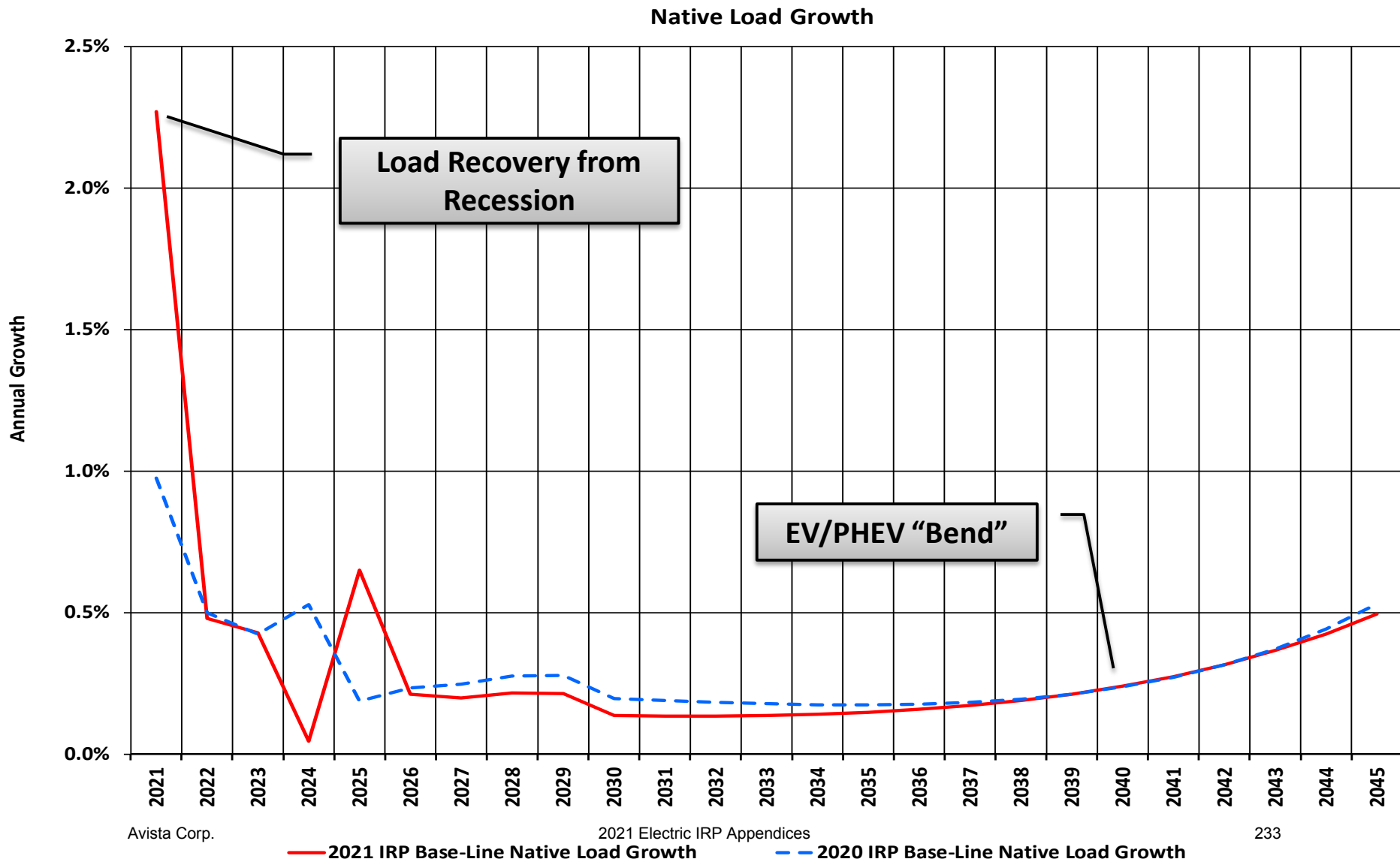

# Residential UPC Growth: 2021-2045

Base-Line Scenario: Residential UPC Growth Rate

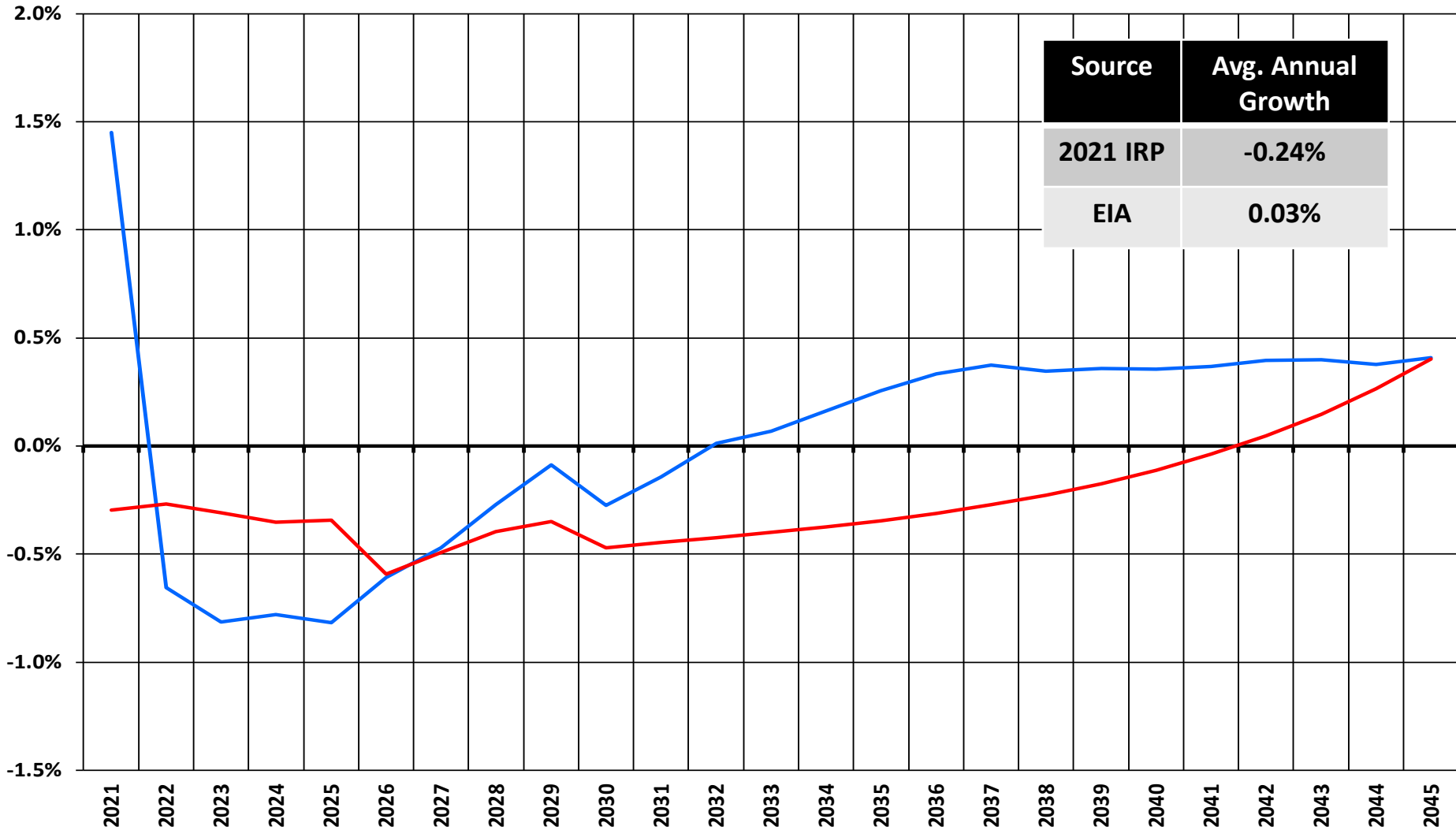



# Long-Run Load Forecast: Conservation Adjustment

Grant D. Forsyth, Ph.D.  
Chief Economist  
[Grant.Forsyth@avistacorp.com](mailto:Grant.Forsyth@avistacorp.com)

# Comparison of Native Load Forecasts, 2021-2045

Average Megawatts Load Comparison with Conservation Adjustment

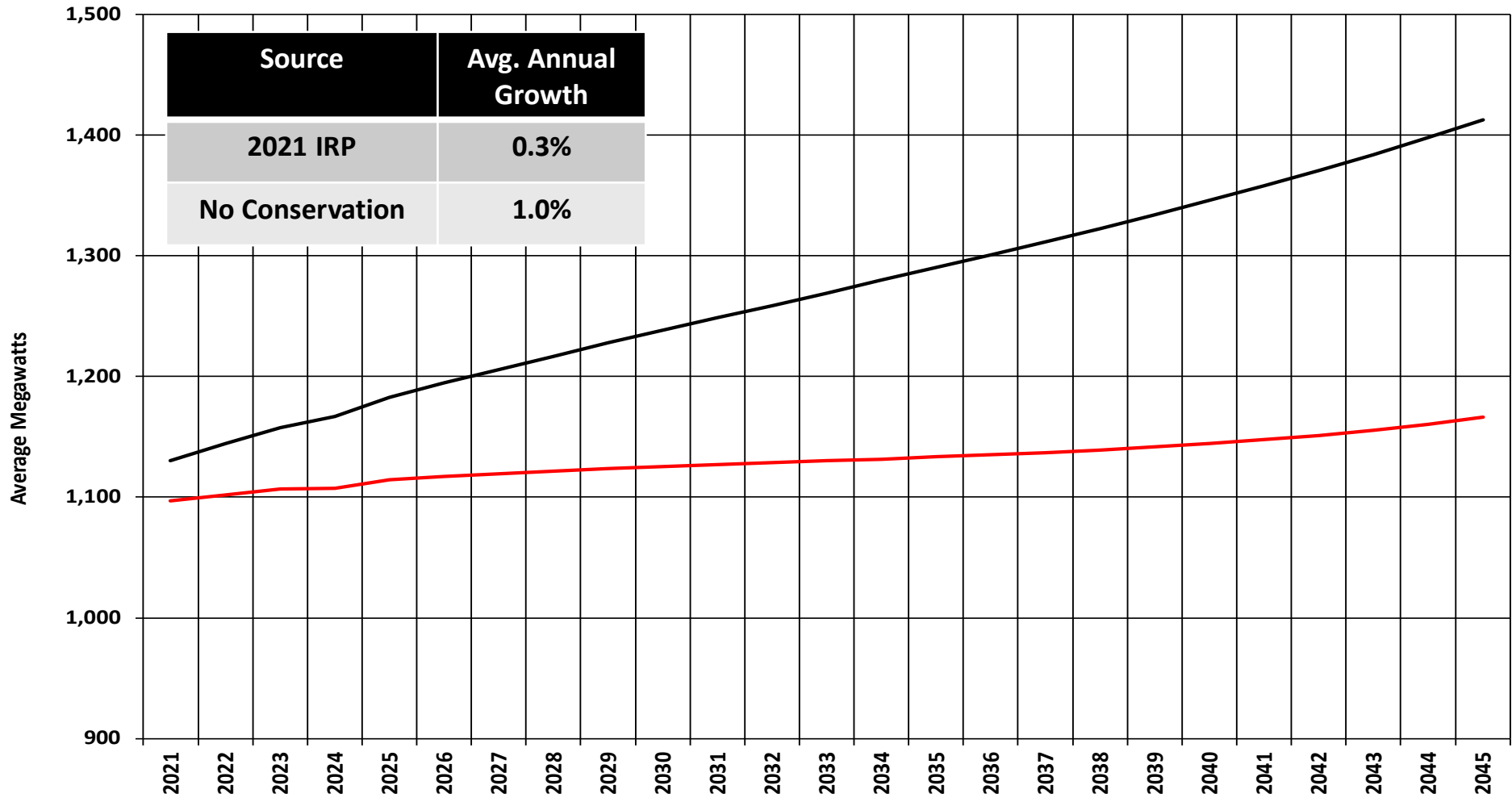



# Peak Load Forecast

**Grant D. Forsyth, Ph.D.**  
**Chief Economist**  
**[Grant.Forsyth@avistacorp.com](mailto:Grant.Forsyth@avistacorp.com)**



# The Basic Model

- **Monthly time-series regression model that initially excludes certain industrial loads and EVs (but those are added back in for the final forecast).**
- **Based on monthly peak MW loads since 2004. The peak is pulled from hourly load data for each day for each month.**
- **Explanatory variables include HDD-CDD and monthly and day-of-week dummy variables. The level of real U.S. GDP is the primary economic driver in the model—the higher GDP, the higher peak loads. *Model allows GDP impact to differ between winter and summer.***
- **The coefficients of the model are used to generate a distribution of peak loads by month based on historical max/min temperatures since 1890, holding GDP constant. A starting expected peak load is then calculated using the average peak load simulated for that month going back to 1890. Model shows Avista is a winter peaking utility for the forecast period; however, the summer peak is growing at a faster than the winter peak.**
- **For comparison in the 2021 IRP, peak load is also calculated by averaging simulated peak loads over the last 30 years and 20 years.**
- **The model is also used to calculate the long-run growth rate of peak loads for summer and winter using a forecast of GDP growth under the “*ceteris paribus*” assumption for weather and other factors.**

# Peak Forecasts for Winter and Summer, 2021-2045

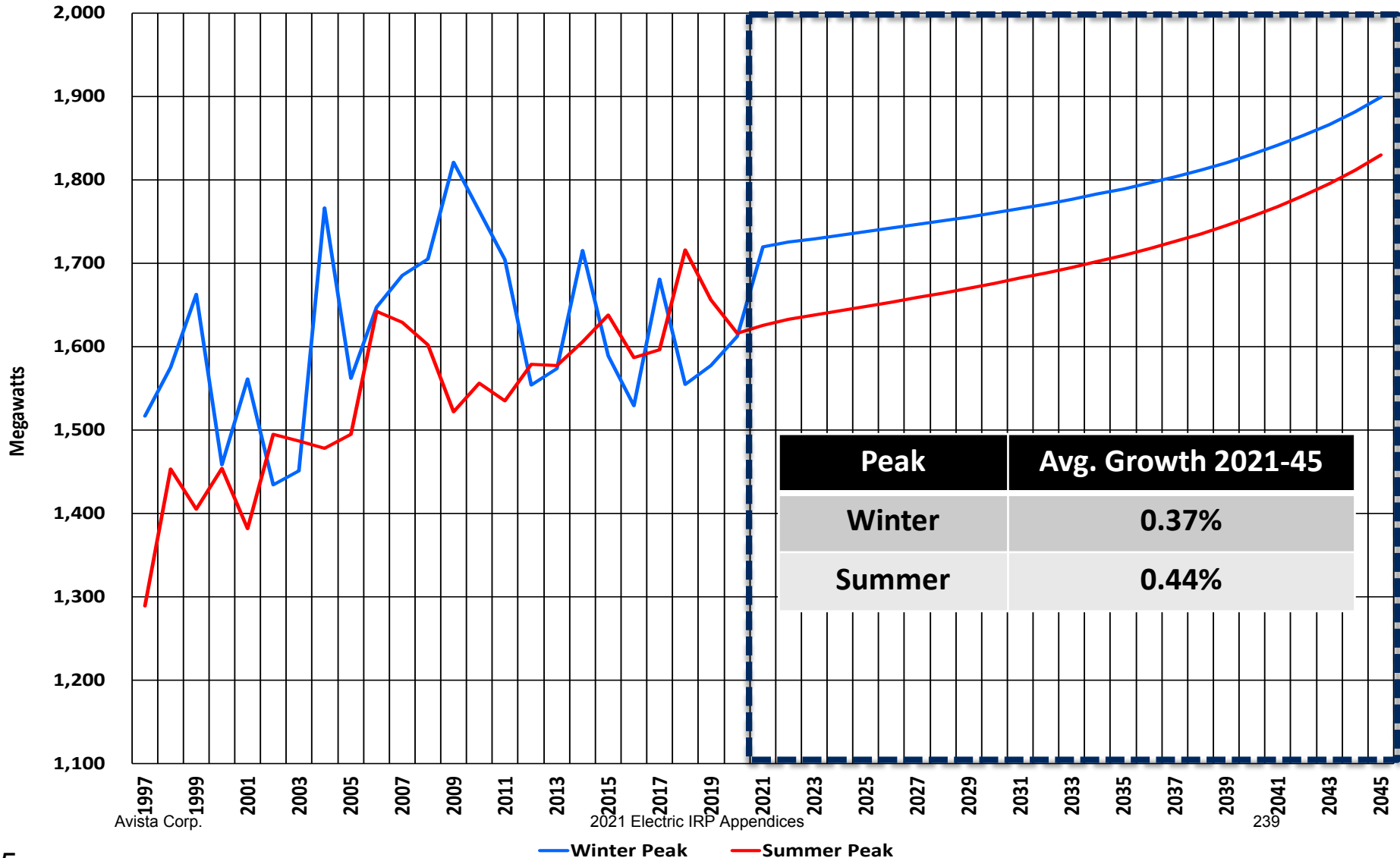

Avista Corp.

2021 Electric IRP Appendices

239

— Winter Peak — Summer Peak

# Load Forecasts for Winter Peak, 2011-2043

Winter Peak Forecast: Current and Past

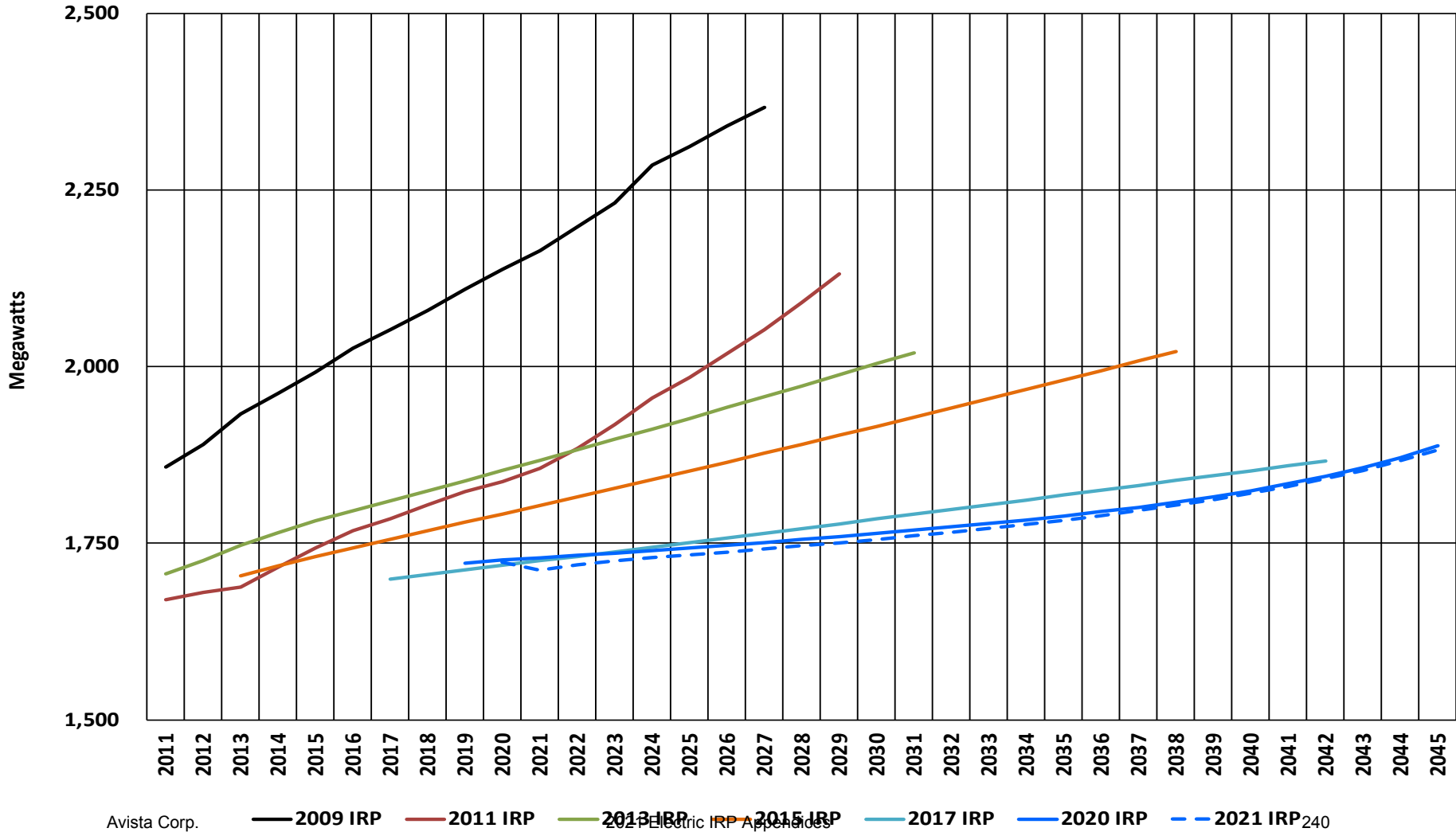

# Load Forecasts for Summer Peak, 2011-2045

Summer Peak Forecast: Current and Past

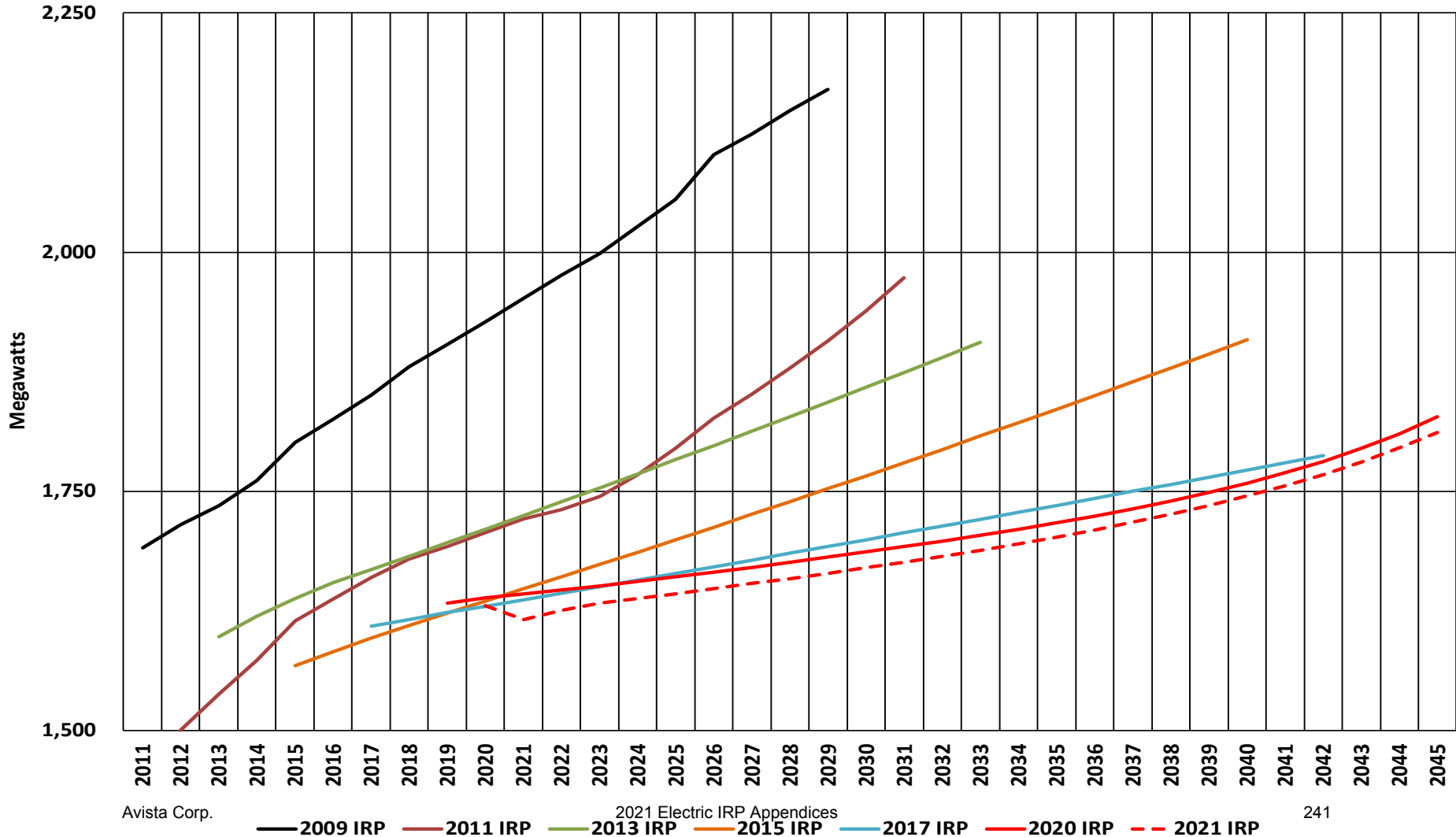

# Peak Forecasts for Winter and Summer 30-Year Average Weather, 2021-2045

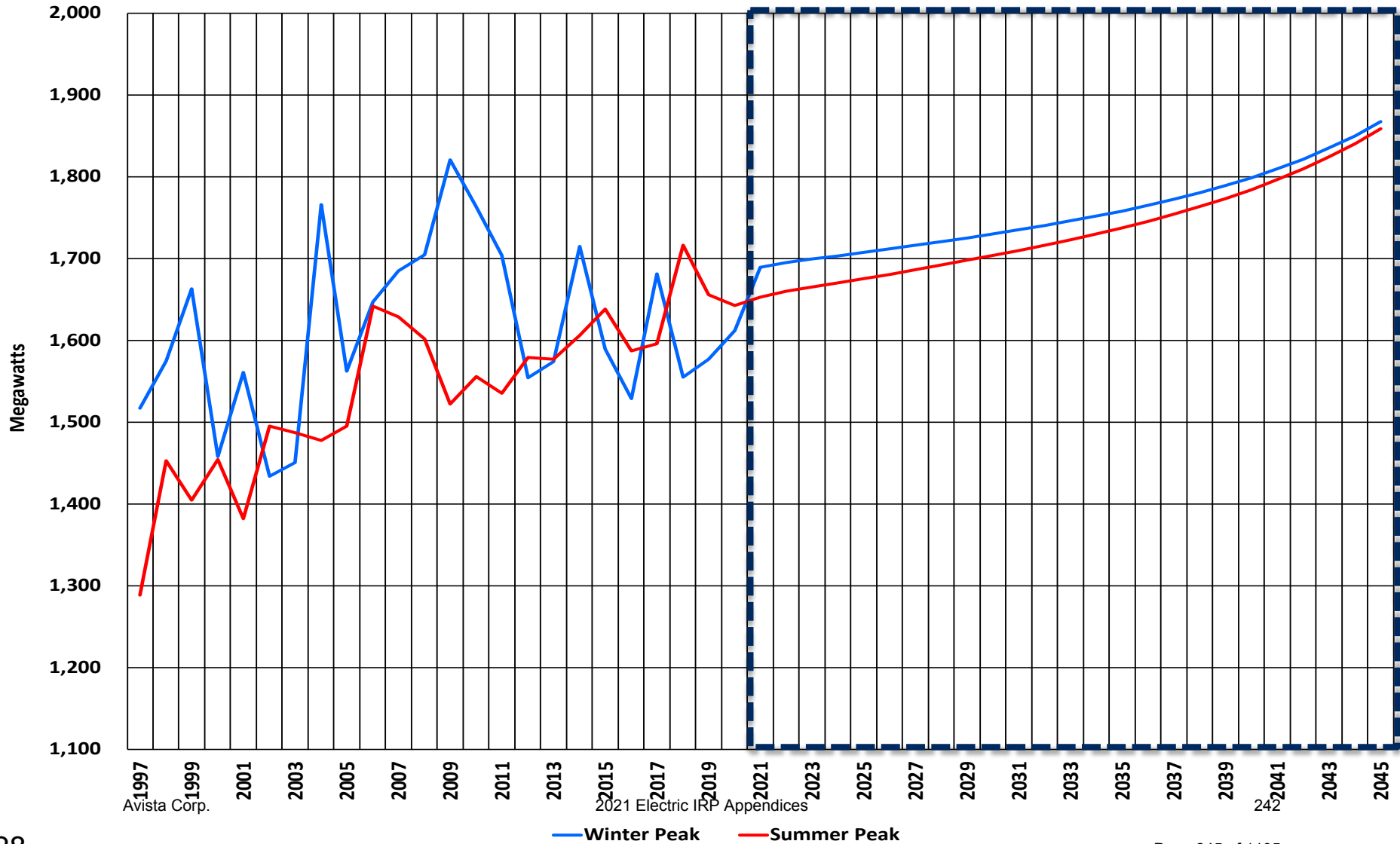

# Peak Forecasts for Winter and Summer 20-Year Average Weather, 2021-2045

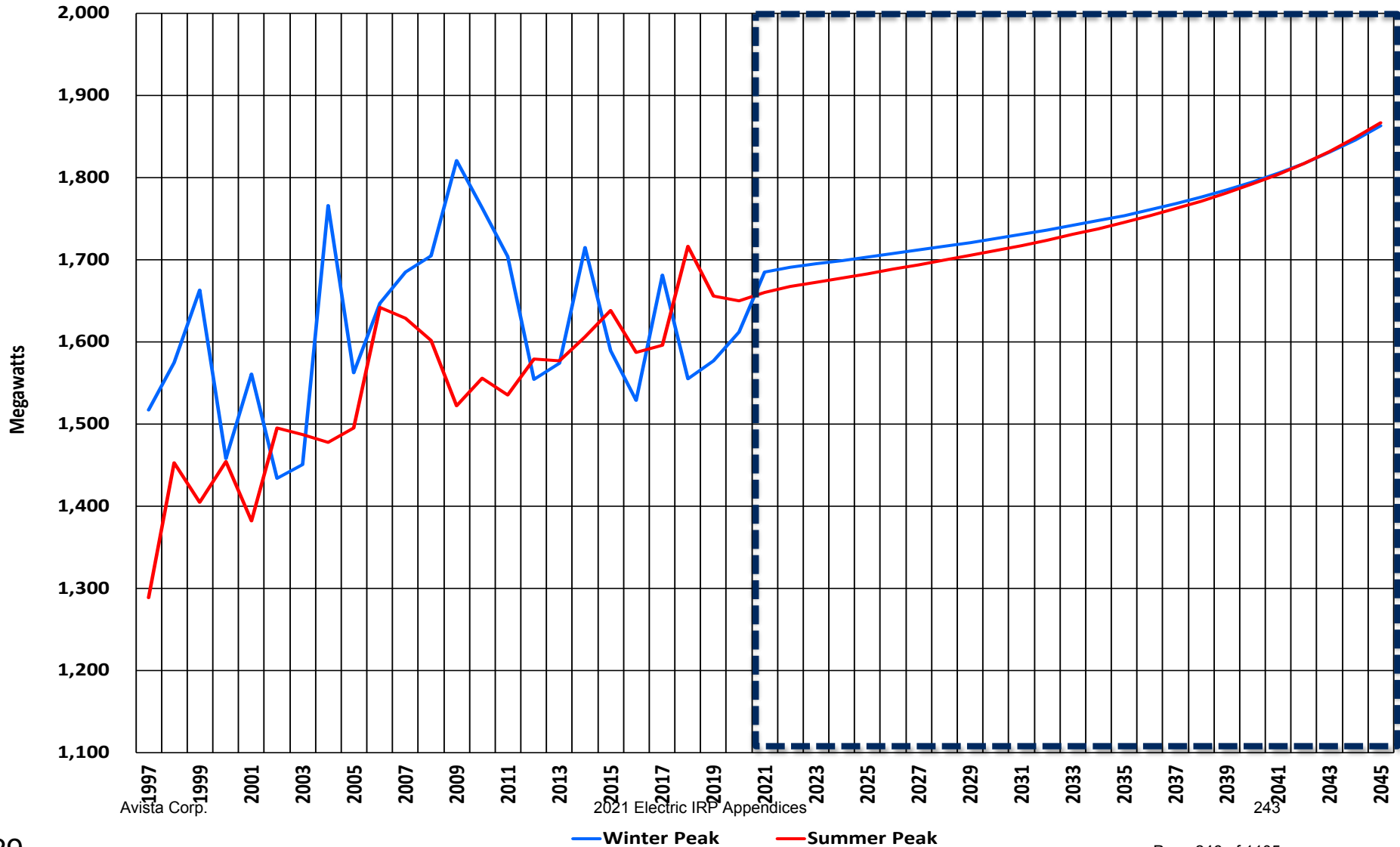



# Long-Run Customer Forecast: Natural Gas

Grant D. Forsyth, Ph.D.  
Chief Economist  
[Grant.Forsyth@avistacorp.com](mailto:Grant.Forsyth@avistacorp.com)

# Firm Customers (Meters) by State and Class, 2019

**Firm Customers by State**

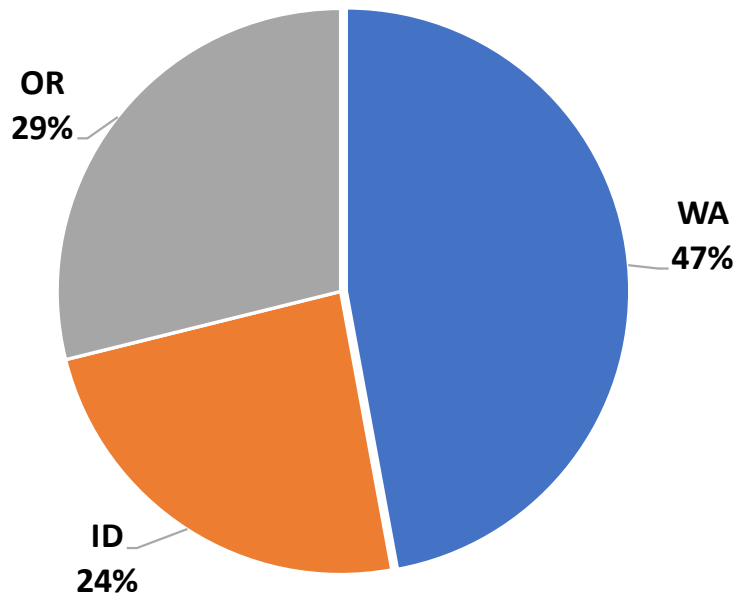

**Firm Customers by Class**

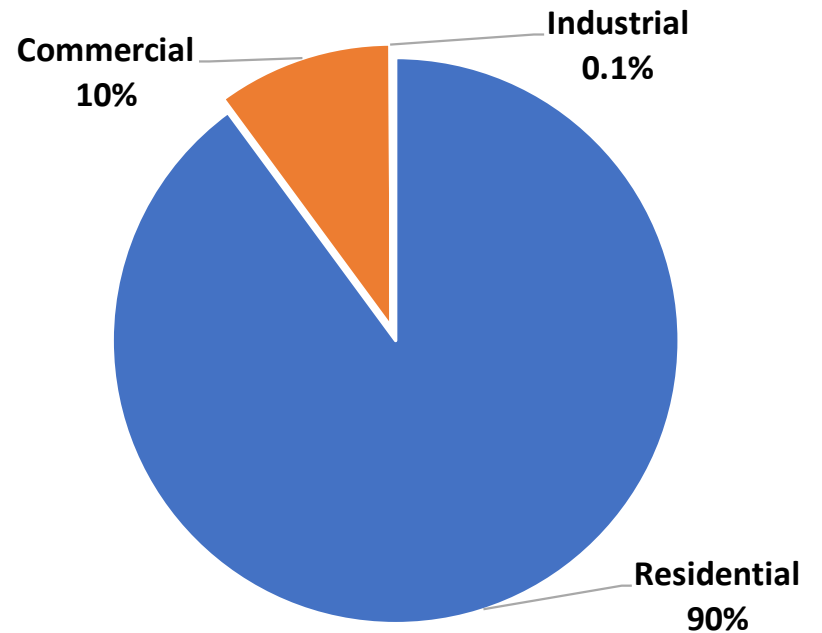



# System All Types of Industrial Customers, 1997-2020

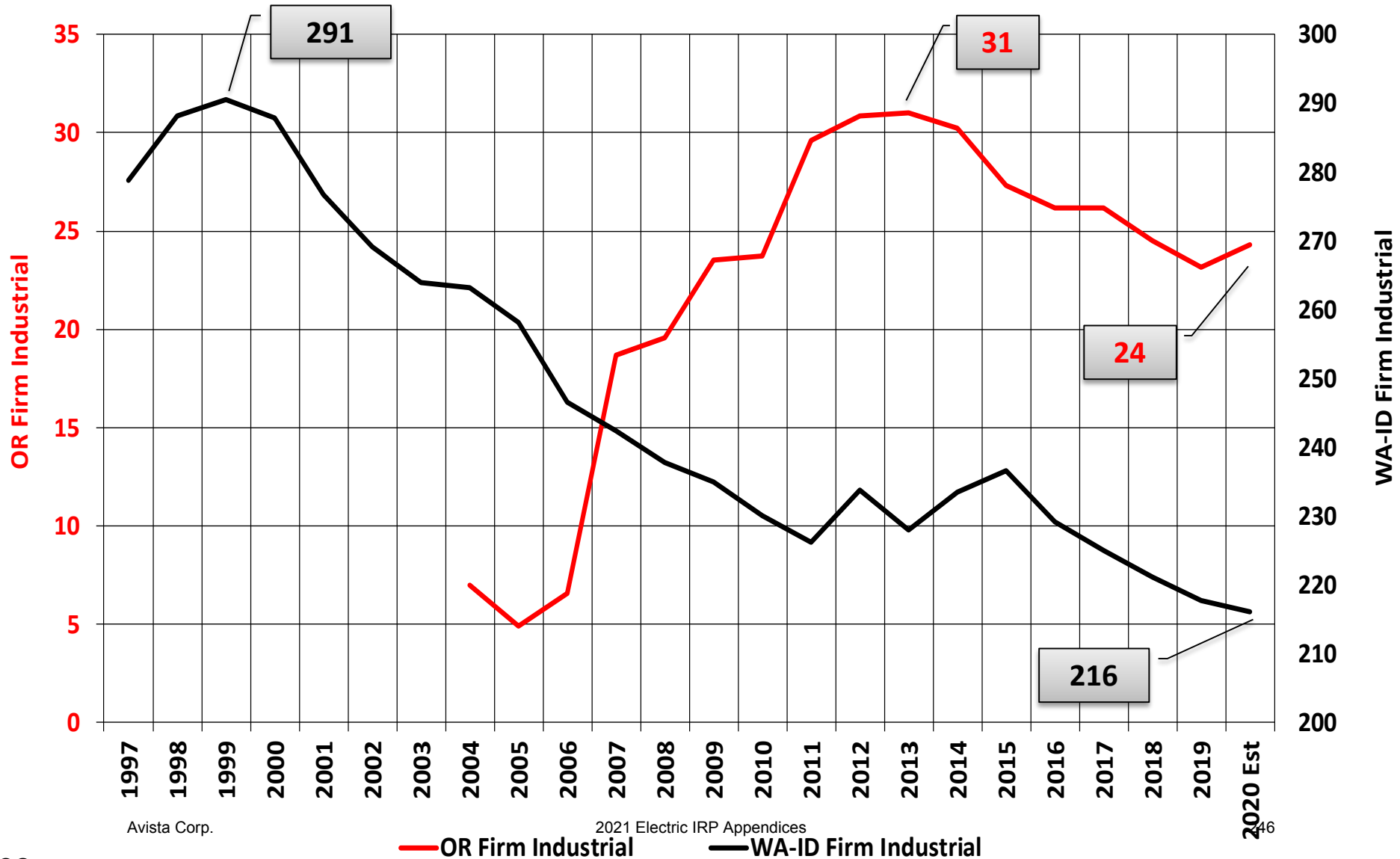

Avista Corp.

2021 Electric IRP Appendices

246

— OR Firm Industrial — WA-ID Firm Industrial

# Customer Forecast Models

- Forecast models are structured around each schedule, in each class, by jurisdiction. In the case of OR, this is done individually for each of Avista's service islands.
- Time series transfer function models (models with regressions drivers and ARIMA error terms).
- Simple time series smoothing models (for schedules with little customer variation).
- Same models used for the bi-annual revenue model forecast pushed out to 2045. The forecasts for this IRP were generated from the "Summer/Fall 2020" forecast completed in June.
- Customer forecasts are sent to Gas Supply for inclusion in the SENDOUT model.
- Example of transfer function model: WA sch. 101 residential customers...

# Transfer Function Model Example

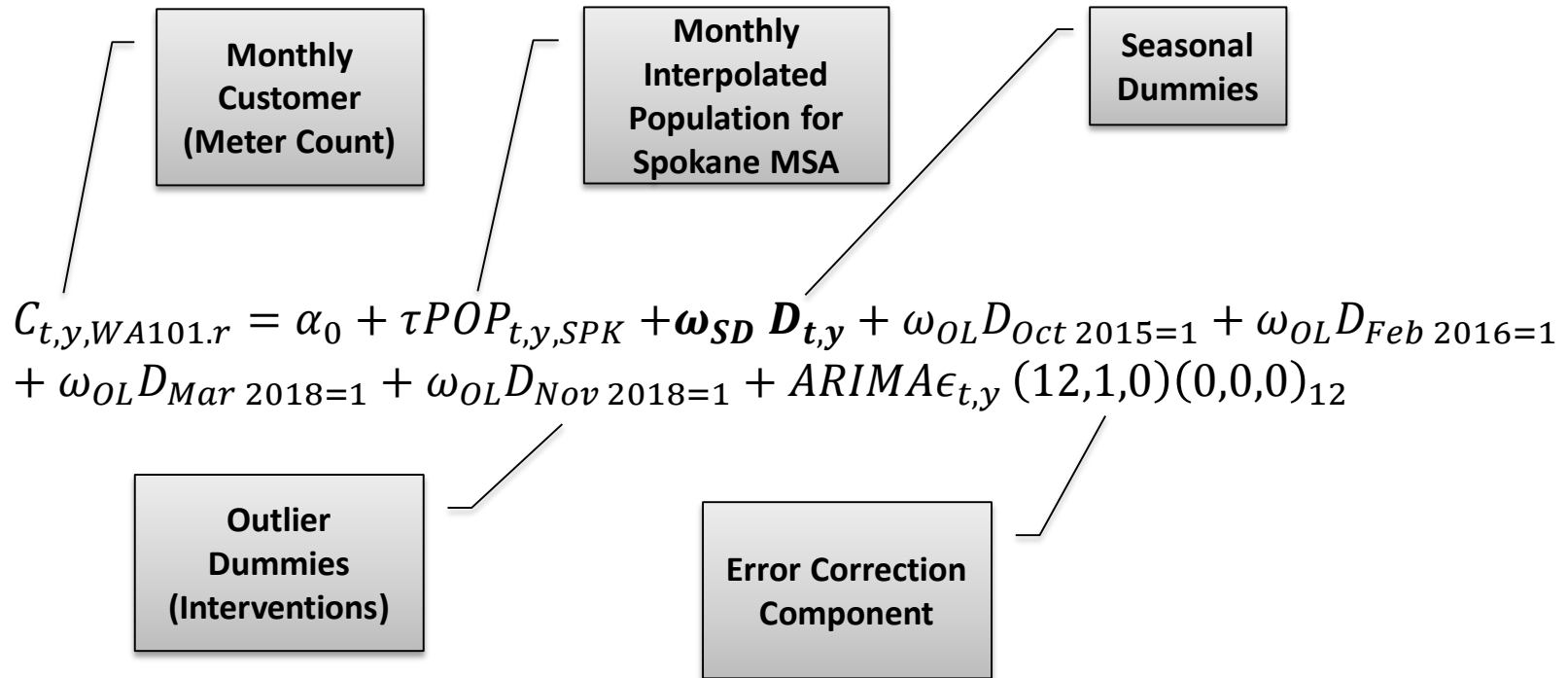

# Getting to Population as a Driver, 2020-2025 & 2026-2045

## 2020-2025 For Spokane, WA; Kootenai, ID, and Jackson+Josephine, OR

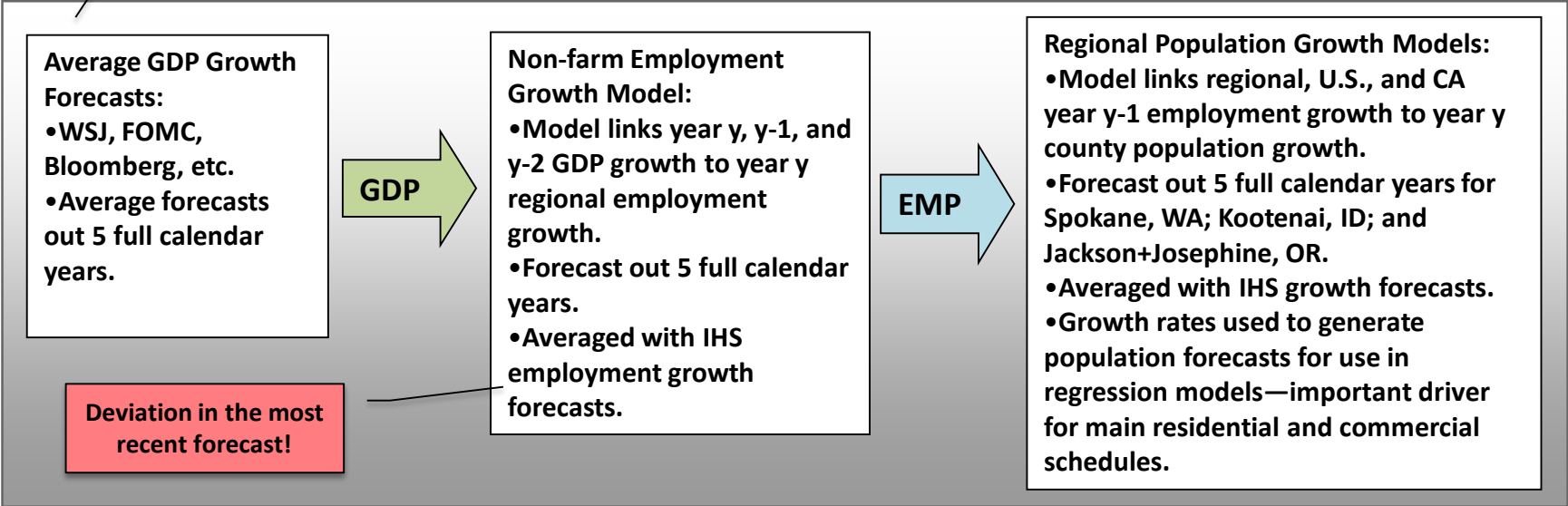

### Kootenai and Jackson: IHS population growth forecasts for 2026-2045

### Spokane: OFM population growth forecasts for 2026-2045

### OR Douglas, Klamath, and Union counties: IHS population growth forecasts for 2020-2045

**Monthly Interpolation assumes:  $P_N = P_0 e^{rN}$**



# WA-ID Region Firm Customers, 2021-2040 (2018 IRP)

IRP	Avg. Annual Growth 2021-2040
2021	1.1%
2018	1.2%

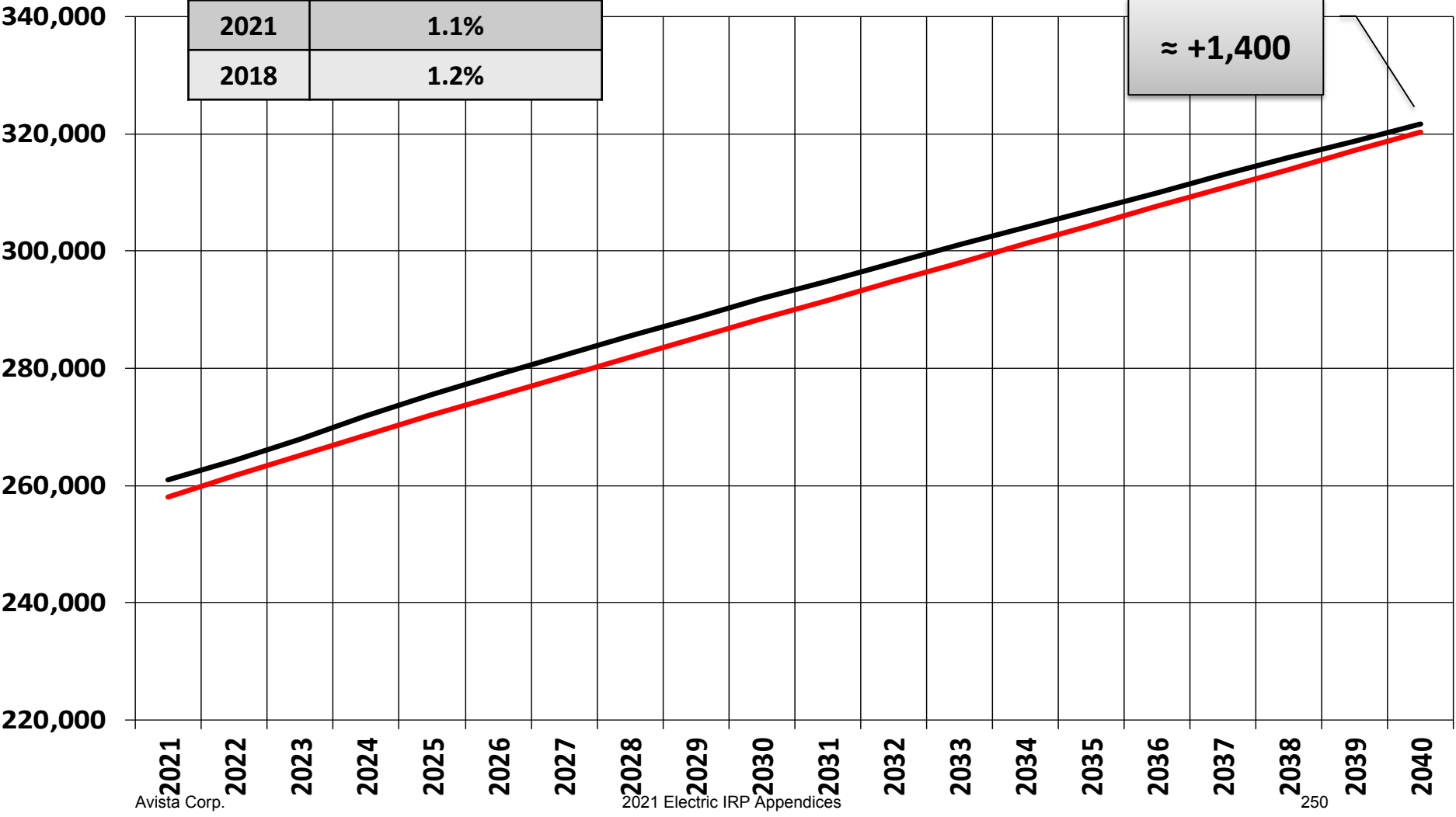

Avista Corp.

2021 Electric IRP Appendices

250

— WA-ID Base-line 2018      — WA-ID Base-line 2021

# OR Region Firm Customers, 2021-2040 (2018 IRP)

IRP	Avg. Annual Growth 2021-2040
2021	0.8%
2018	0.9%

≈ -2,800

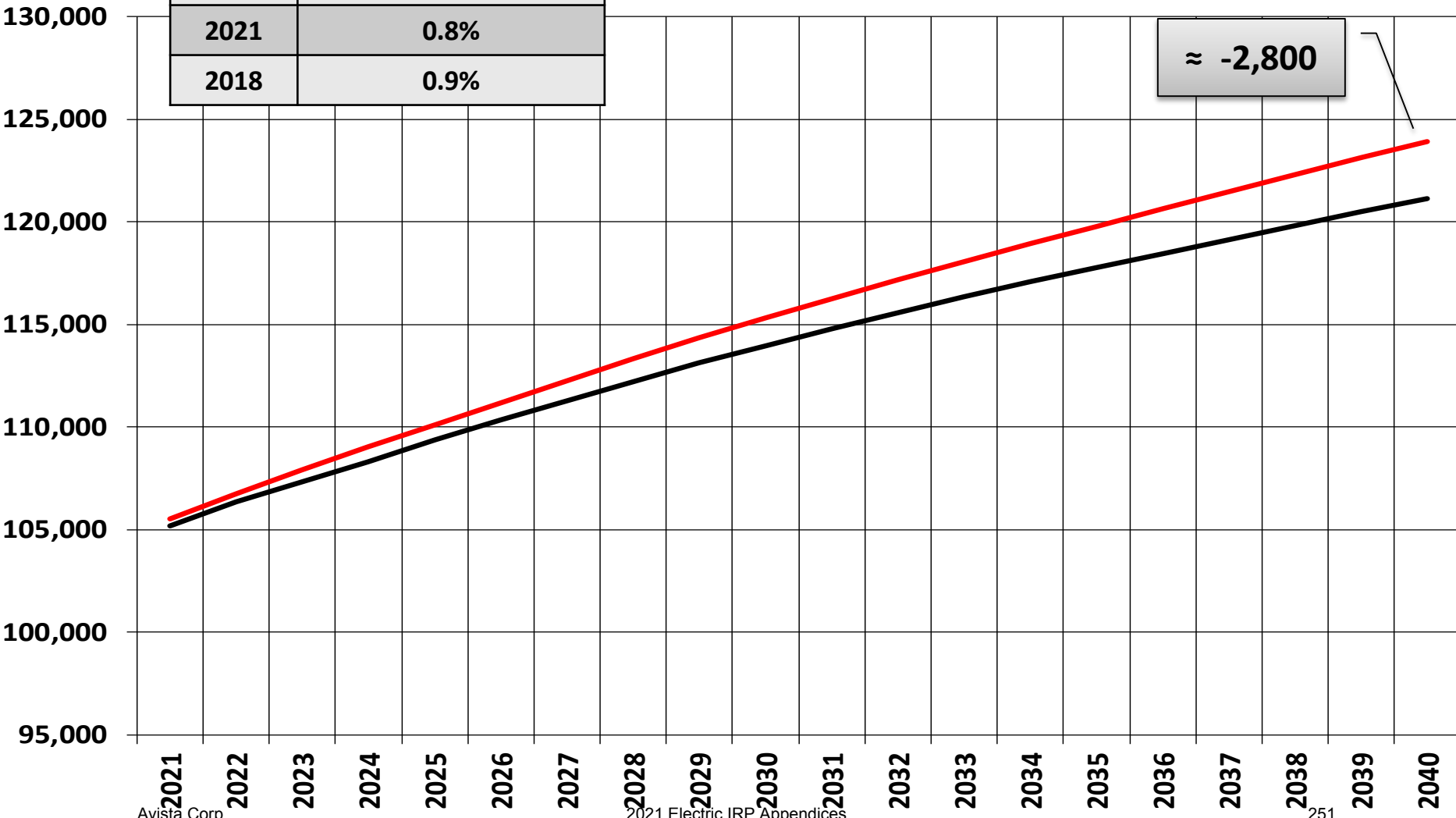

Avista Corp.

2021 Electric IRP Appendices

251

— OR Base-line 2018 — OR Base-line 2021

# Medford, OR Region Firm Customers, 2021-2040 (2018 IRP)

IRP	Avg. Annual Growth 2021-2037
2021	0.9%
2018	0.9%

≈ +310

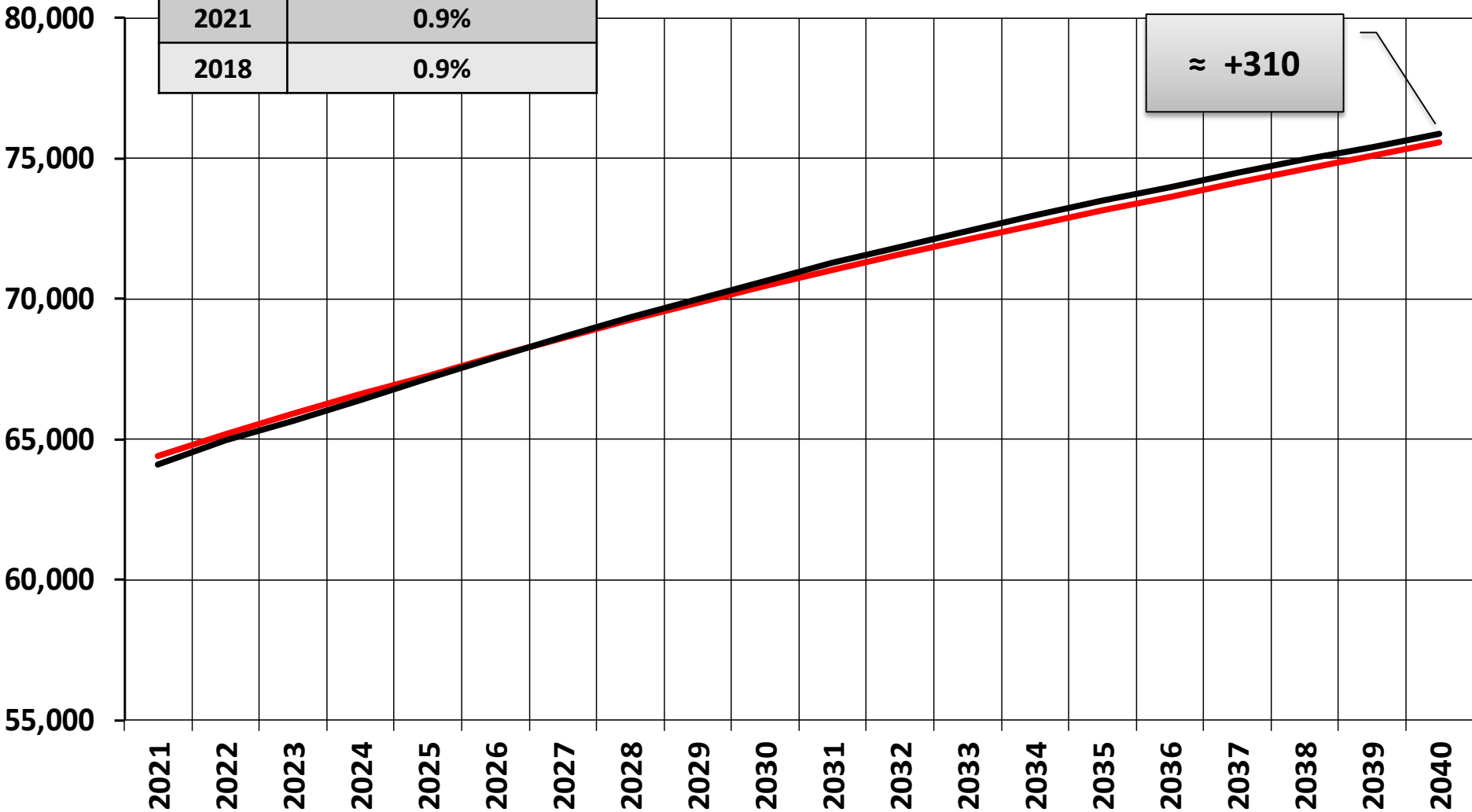

# Roseburg, OR Region Firm Customers, 2021-2040 (2018 IRP)

IRP	Avg. Annual Growth 2021-2040
2021	0.4%
2018	0.9%

≈ -1,900

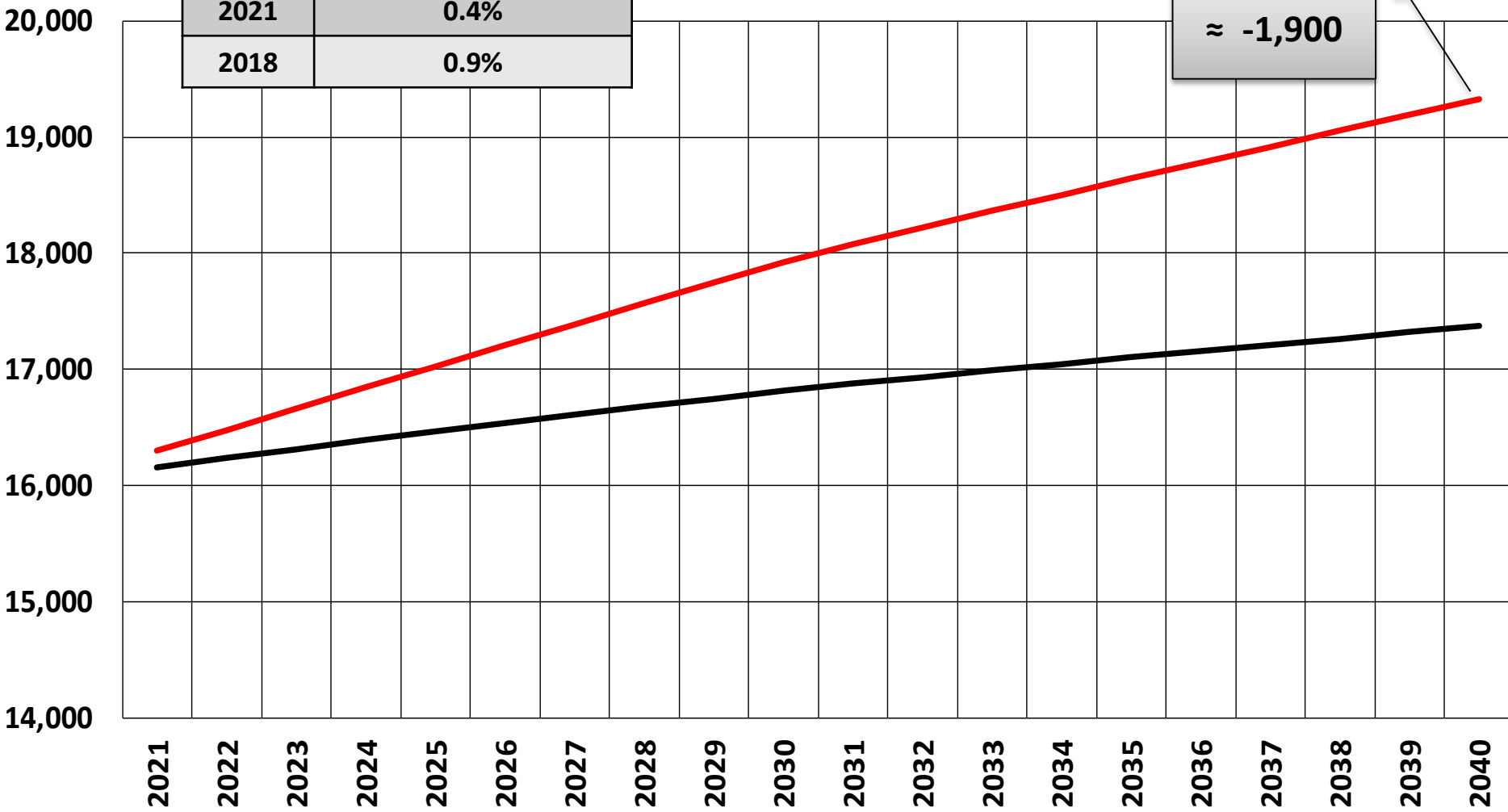



# Klamath, OR Region Firm Customers, 2021-2040 (2018 IRP)

IRP	Avg. Annual Growth 2021-2040
2021	0.7%
2018	1.0%

≈ -1,200

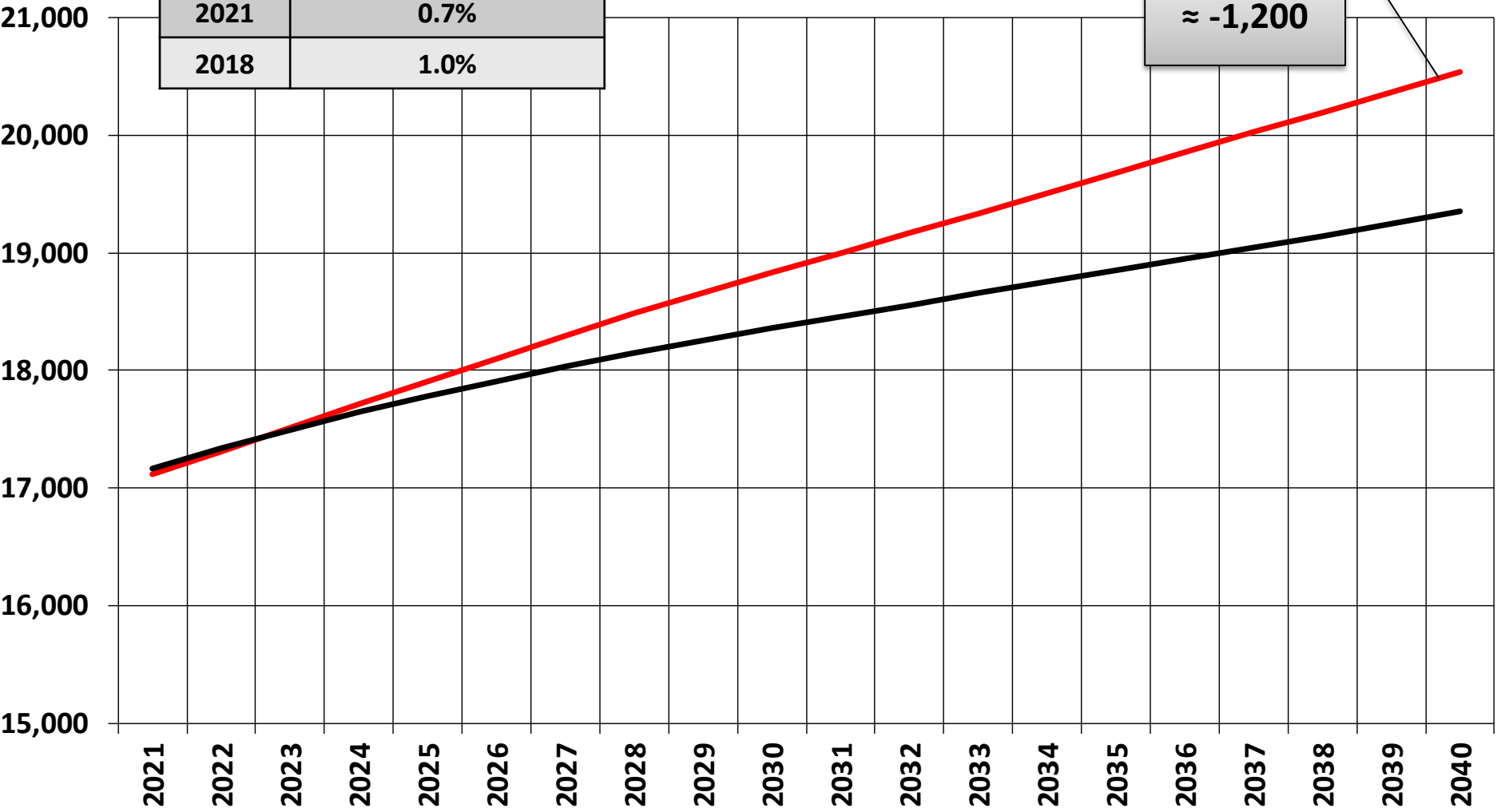

Avista Corp.

2021 Electric IRP Appendices

254

**— Klamath Base-line 2018**      **— Klamath Base-line 2021**

# La Grande, OR Region Firm Customers, 2021-2040 (2018 IRP)

IRP	Avg. Annual Growth 2021-2040
2021	0.5%
2018	0.5%

≈ +30

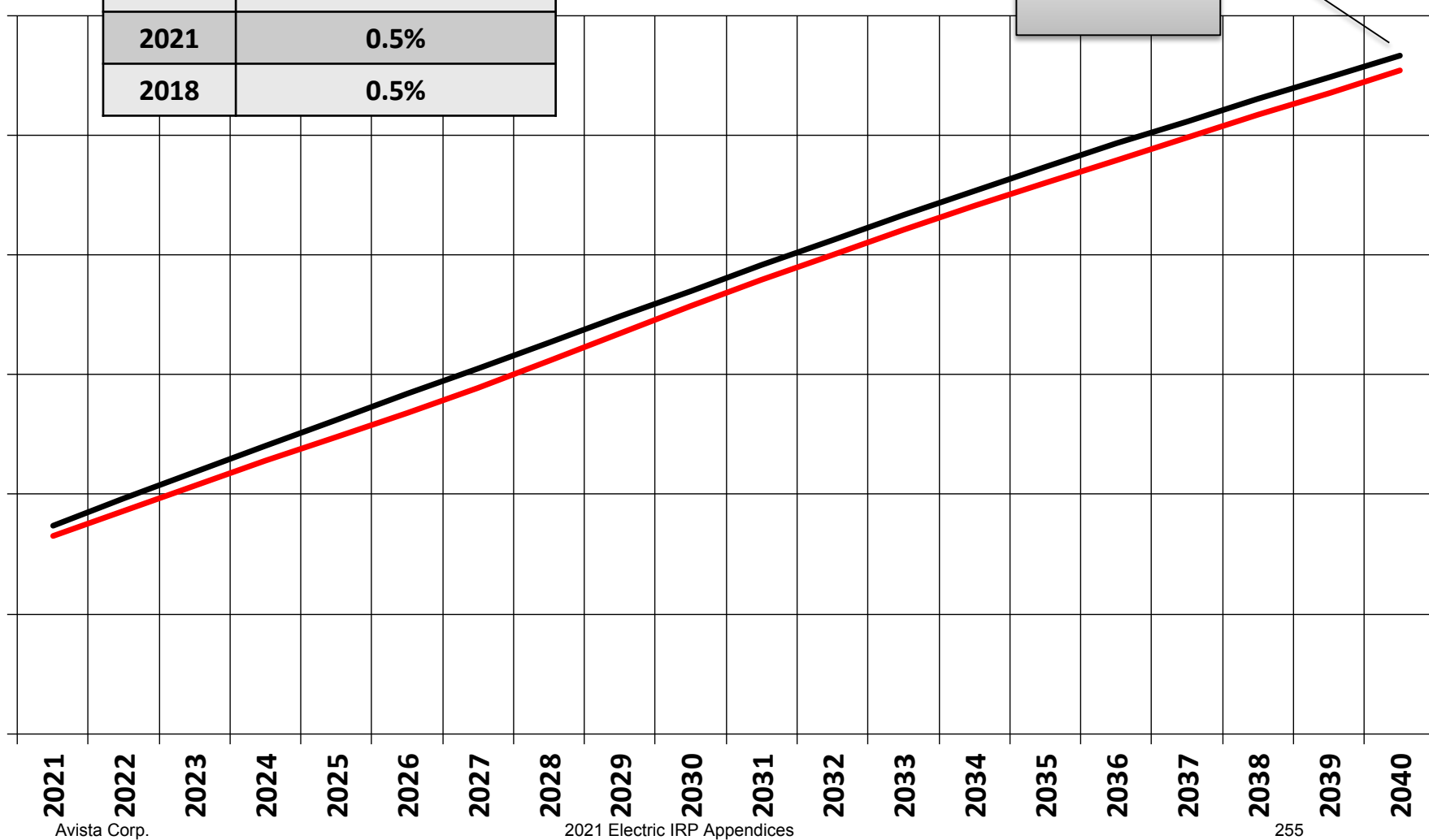

Avista Corp.

2021 Electric IRP Appendices

255

— La Grande Base-line 2018      — La Grande Base-line 2021

# System Firm Customers, 2021-2040 (2018 IRP)

IRP	Avg. Annual Growth 2021-2040
2021	1.0%
2018	1.1%

≈ -1,400

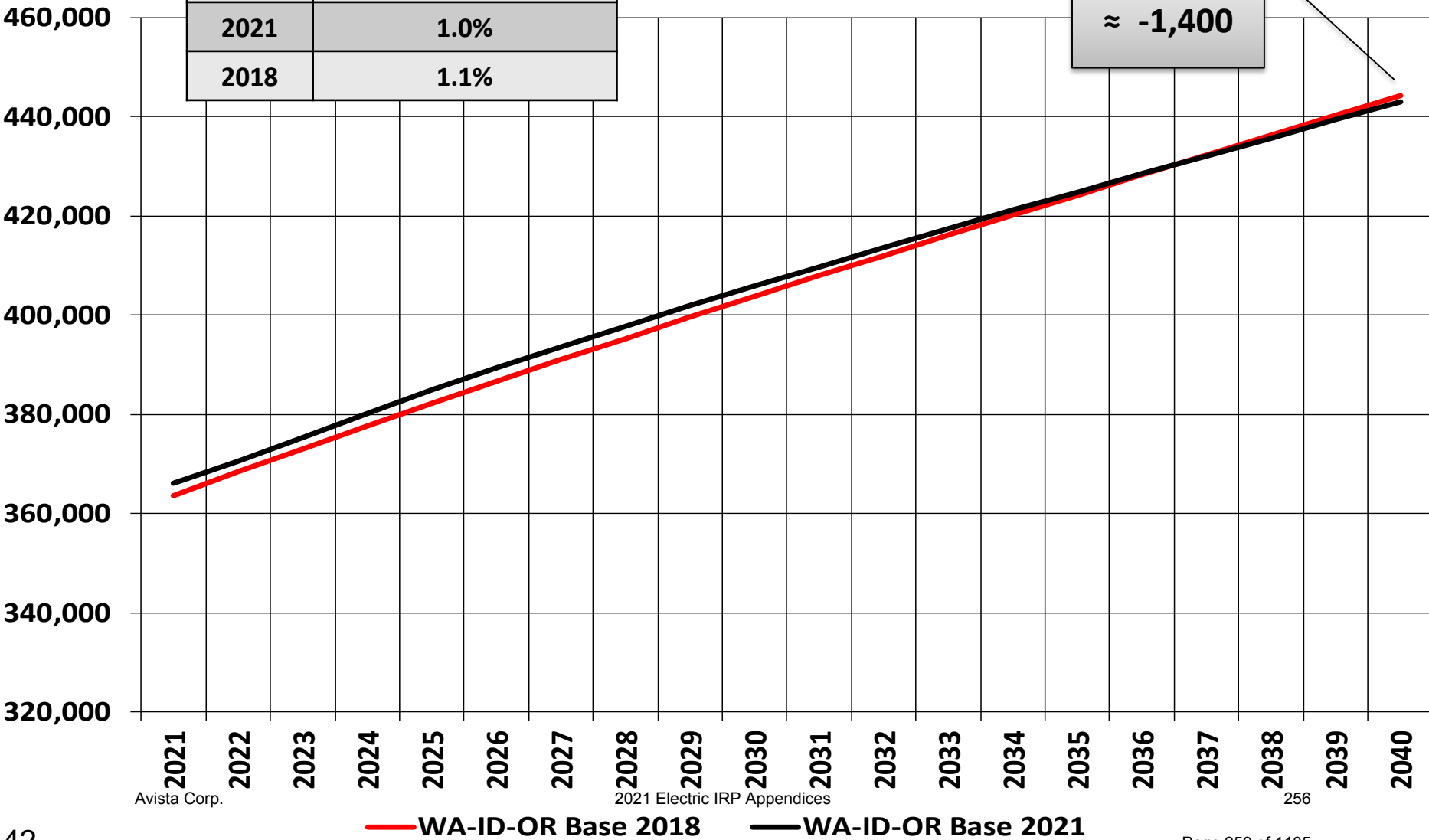

# WA-ID Region Firm Customer Range, 2021-2045

Variable	Low Growth	Base Growth	High Growth
WA-ID Customers	0.7%	1.1%	1.5%
WA Population	0.4%	0.7%	1.0%
ID Population	0.8%	1.4%	2.0%
WA-ID Population	0.5%	0.8%	1.2%

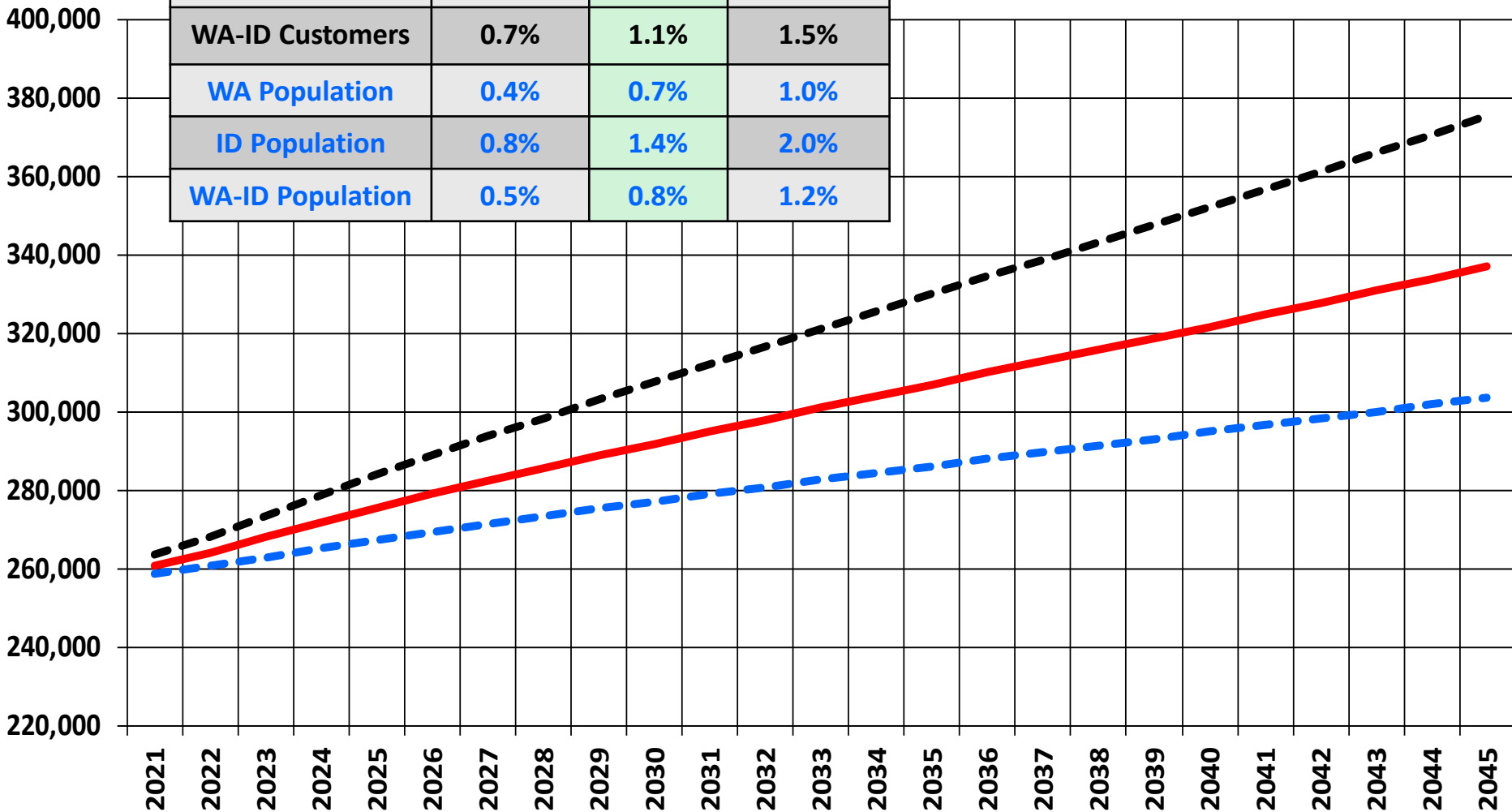

# OR Region Firm Customer Range, 2021-2045

Variable	Low Growth	Base Growth	High Growth
Customers	0.5%	0.7%	0.9%
Population	0.3%	0.5%	0.7%

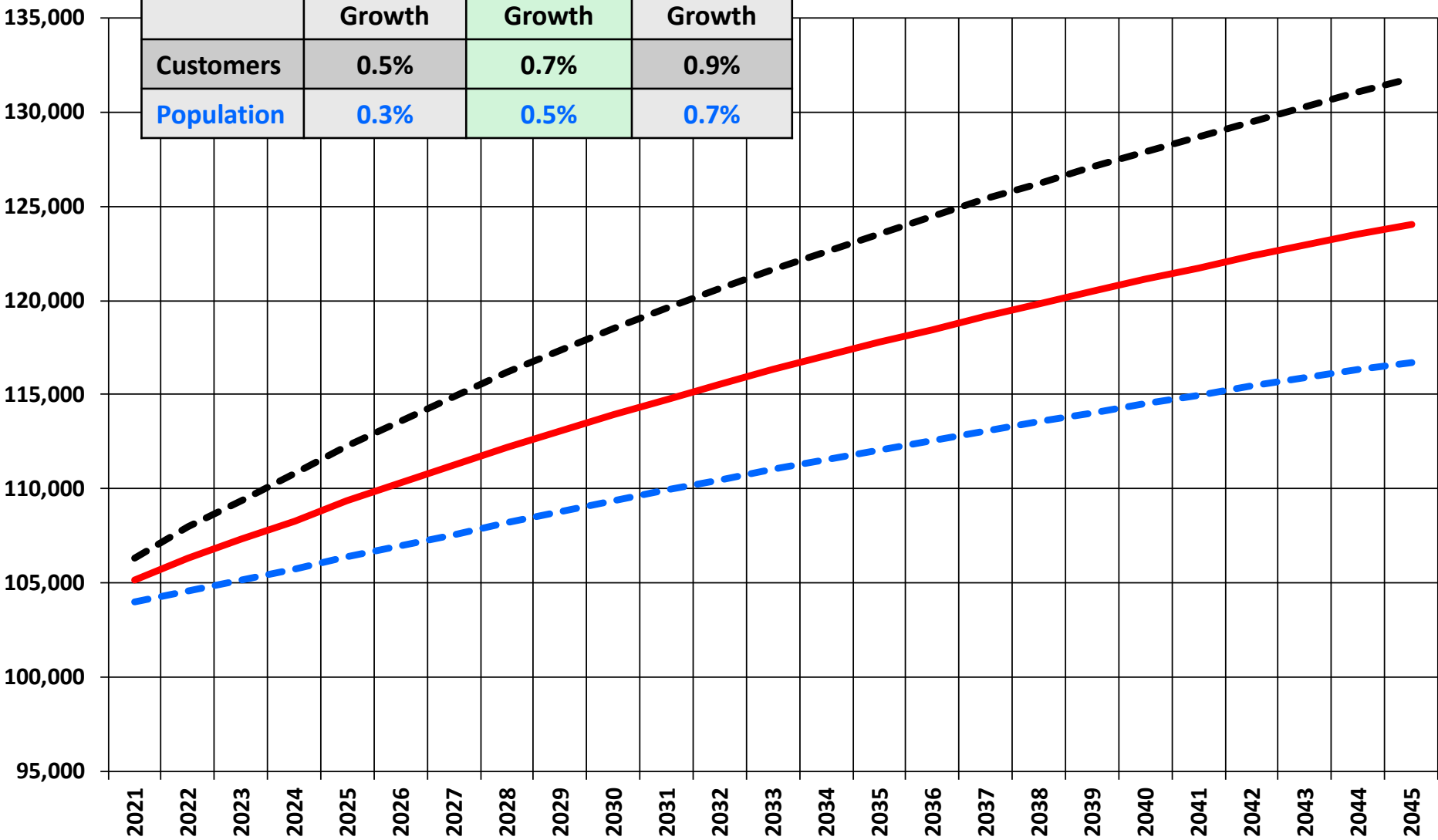

Avista Corp.

2021 Electric IRP Appendices

258

— ORFIRMCUS Base    - - - ORFIRMCUS High    - - - ORFIRMCUS Low

# System Firm Customer Range, 2021-2045

Variable	Low Growth	Base Growth	High Growth
Customers	0.6%	1.0%	1.3%
Population	0.4%	0.8%	1.1%

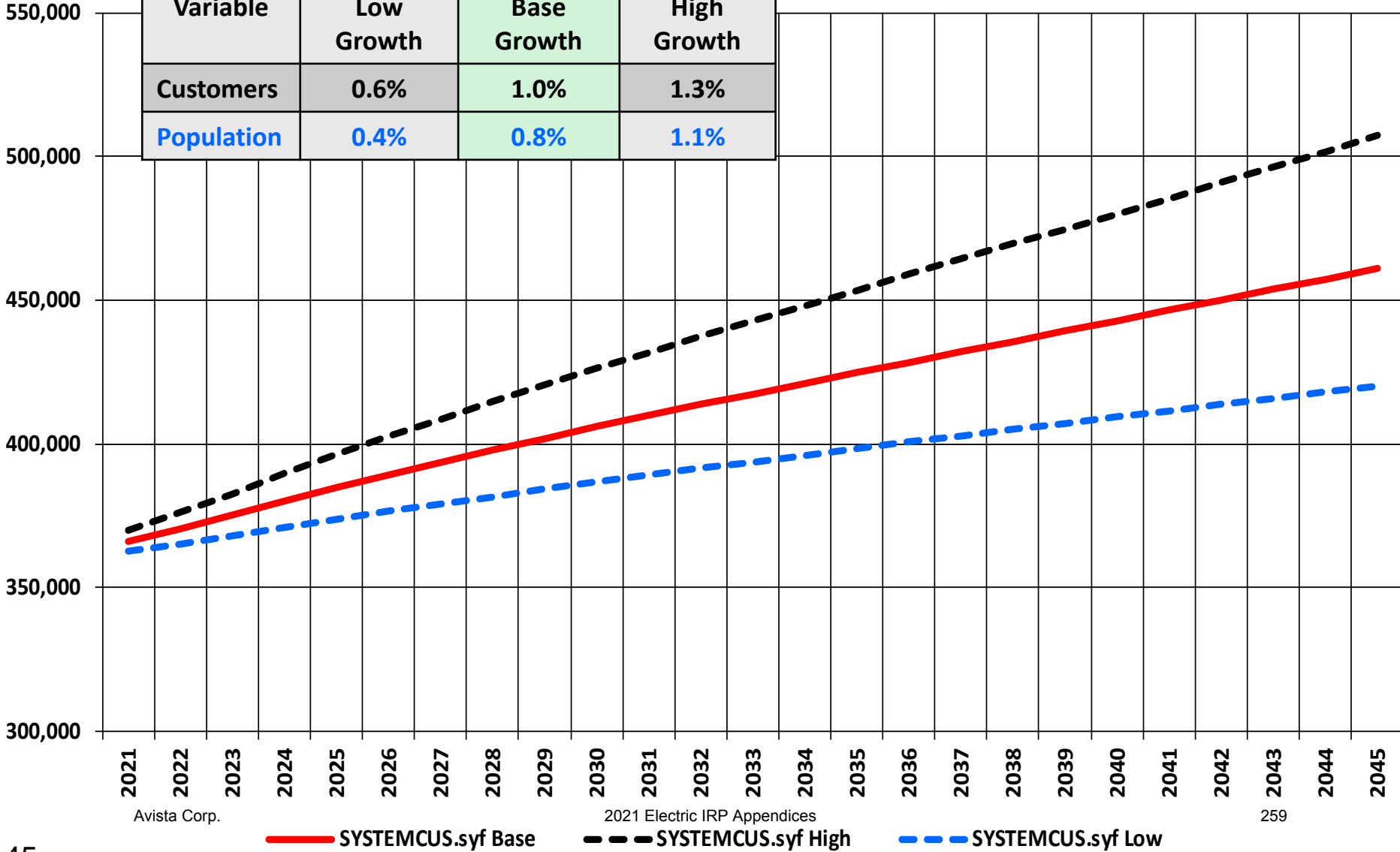

# Summary of Growth Rates

System	Base-Case	High	Low
Residential	1.0%	1.4%	0.7%
Commercial	0.5%	0.8%	0.1%
Industrial	-0.8%	2.2%	-3.8%
Total	1.0%	1.3%	0.6%
<b>WA</b>			
System	Base-Case	High	Low
Residential	1.0%	1.3%	0.7%
Commercial	0.4%	0.7%	0.1%
Industrial	-0.8%	1.9%	-3.6%
Total	1.0%	1.3%	0.7%
<b>ID</b>			
System	Base-Case	High	Low
Residential	1.4%	2.0%	0.8%
Commercial	0.4%	1.0%	-0.2%
Industrial	-1.0%	1.8%	-3.4%
Total	1.3%	1.9%	0.7%
<b>OR</b>			
System	Base-Case	High	Low
Residential	0.7%	0.9%	0.5%
Commercial	0.6%	0.8%	0.4%
Industrial	0.0%	4.5%	-10.6%
Total	0.7%	0.9%	0.5%

## TAC 2.5 Meeting, September 18, 2020

**Virtual Meeting Attendees:** Nikita Bankoti, Washington UTC; Ben Cartwright; John Chatburn, Idaho Energy Office; Corey Dahl, Washington Public Counsel; Ashton Davis; Daniel Hua, NPPC; Kevin Keyt, IPUC; State of Idaho; Katie Pegan, OEMR; Steve Johnson, Washington UTC; Charles Pegan; Dan Kirschner, NW Gas Association; Fred Huette, NWECA; Gina Saraswati; Kate Griffith, Washington UTC; Joni Bosh, NWECA; L Molander; Devin McGreal, Cascade Natural Gas; Michael Eldred, IPUC; Mike Morrison, IPUC; Morgan Brummund, Idaho Energy Office; Greg Nothstein, Washington Department of Commerce; Andrew Rector, Washington UTC; Richard Keller, IPUC; Ken Ross, Fortis; Sudeshna Pal, Oregon CUB; Ted Light; Terrence Browne, Avista; Vlad Gutman-Britten, Climate Solutions; Yao Yin, IPUC; Tom Pardee, Avista; Jody Morehouse, Avista; Jaime Majure, Avista; Paul Kimmell, Avista; Theophania Labay, Avista; John Lyons, Avista; Lori Hermanson, Avista; James Gall, Avista; Grant Forsyth, Avista; Ryan Finesilver, Avista; Michael Brutocao, Avista; Mike Tatko, Avista; Amanda Ghering, Avista; Clint Kalich, Avista; Shawn Bonfield, Avista; Marissa Warren, IPUC; two Unavailable; and four Guests

Replies in *italics* after questions are made by the presenter in the following notes.

### **Economic Load and Customer Forecast (TAC 2.5)**

**Grant Forsyth:** MSA stands for metropolitan service areas. Includes Spokane, Coeur d'Alene, Lewiston/Clarkston, and Grants Pass in our service territory.

**Grant Forsyth:** [Slide 4]: Most or 2/3 is local government, and half or more of government employment is for education.

**Grant Forsyth:** 2008 slowing job opportunities. Population growth means more job opportunities. About 0.5% growth, 80-100% in-migration influencing load growth.

**Steve Johnson:** Now, generally speaking is there about a year lag between employment growth and population about a year later? *Yes, about that.*

**Steve Johnson:** Population drives service territory growth. Do we know why 2014 surged above the nation? *A little late in the process. Retirement demographic, jobs.* What does it correlate to GDP, higher or lower? *Multiple reasons. Employment is a primary driver. It has been an OK predictor in the past, but talk to people in real estate and a robust economy comes with job growth. Low housing costs bring equity refugees to the area after selling a house.* OK, thanks.

**Steve Johnson:** Is there a separate forecast for layoffs that local governments might do in the next 1.5 years and the rate of government job growth after that 1.5 year period? *No, it looks at total employment growth and the lagged by a year population growth.*

**Grant Forsyth:** Employment is also part of the GDP growth forecast based on an average of forecasts, at least over the medium term out to 2025. Big difference from



June 2019 to June 2020 with a 6 percent decline in GDP, expect 4 percent growth next year and then back down to 2 percent growth after 2022.

**Andrew Rector:** Do you run sensitivities on the growth rates? *Yes, did run sensitivities on this lately because of the COVID crisis with different types of recessions. The most sensitive is the industrial side. Slowed employment growth slows customer growth for two years after the recession, but clearly the most sensitive is industrial. Does that answer your question?* Yes, it does.

**Grant Forsyth:** Last year, I was asked to look at load if there was a recession every six years. Found that we get to the same place, but more volatility builds more noise into the model.

**James Gall:** There will be a high and a low load growth scenario. Not sure if we have it later, but we can add it to the slide deck later.

**Steve Johnson:** There are various GDP underlying assumptions of how COVID plays out. In regards to GDP estimates you used, do you know what the underlying assumption was related to COVID and how that plays out?

**Grant Forsyth:** In some forecasts you can observe the underlying assumptions and some you cannot. Some were predicting various things about COVID. Some were V shaped, some square root, and others W shaped. But averaged together you get the red line on Slide 7.

**Steve Johnson:** Does the company have an idea of how they think it'll play out from the scientists and economists?

**Grant Forsyth:** I'm allowed some discretion with that, but I tend to stick with a forecast procedure that the Commissions are aware of and familiar with. I did not use a lot of discretion using epidemiological sources. That is something I thought I'd never be asked looking back on forecasts.

**Steve Johnson:** Is it the company's forecast looking at the scientific community's look at a second wave? Do you think that is realistic? Does the Company agree a second wave is sound scientific reasoning?

**Grant Forsyth:** When this was first going on people like me stopped forecasting early in COVID. Even the Fed [U.S. Federal Reserve] stopped providing guidance. Started to look at economists forecasting with epidemiologist input for one, two or three waves, but it didn't provide that much guidance that largely impact the forecast. The NEBR [National Bureau of Economic Research] looked at how the Spanish Flu [in 1918].

**Slide #9:** Medium term of 2020 – 2025 is what we used in the revenue and earnings model in June 2020. 20-year moving average of weather (2000-2019) that gets updated every year.

**Andrew Rector:** When you say price do you mean price of electricity? *Yes, own price of electricity. Typically all-in annual prices – all revenues divided by usage for that schedule)*

**Nikita Bankoti (Slide #9):** Is GDP based on growth assumptions weighted a lot from 2020-2025?

**Grant Forsyth:** Good question. Typically what I'll do is to not increase uncertainty in the short run GDP for that period. I don't necessarily increase the uncertainty from that period.

**Nikita Bankoti:** I'm trying to understand if you assign an equal weight to GDP?

**Grant Forsyth:** Essentially a consensus as GDP filters through but no weighting. Washington State weights their revenue model. I use a single GDP treated as a consensus and drive that through the model. I don't have any weightings like the state does.

**Nikita Bankoti:** OK, that makes sense.

**Mike Morrison:** Multiplying customers by UPC isn't difficult, mathematically. Why did you use an approximation at all?

**Grant Forsyth:** I'm making sure everyone understands since not everyone does this kind of work, so I start from the beginning and build up from there. There two component parts you need to worry about to determine what's driving load. Customer growth and use per customer growth are the main things.

**Andrew Rector:** Can you say again? Overall the 0.8% is the same as the 2020 forecast, but shaped differently, is that what you're saying?

**Grant Forsyth:** Yes. Taking it a step further, long term population growth is about 0.8% on average. The U.S. is about 0.5% growth, so there is embedded in the forecast a certain amount of in-migration for our service area.

**Mike Morrison:** Red line, increases and then precipitous drop in 2026 – what's the drop coming from?

**Grant Forsyth:** Long-term forecasts. That drop reflects what the third-party forecaster are thinking will happen. Really the IHS forecast that can change from IRP to IRP based on their own modeling processes. The OFM forecast is more stable because they don't update as often as IHS.

**Steve Johnson (slide #12):** Is this acceleration in Washington state and related to incentives and programs?

**Grant Forsyth:** Washington probably dominates; if you look at customers who have solar, it's weighted to Washington. It is an assumption that we update as we get more information. The cost has come down a lot on solar and that encourages more solar

adoption. Also technological changes – roofs that look like shingles, but it's actually solar.

**Steve Johnson:** Are you modeling commercially available?

**Grant Forsyth:** Some are available and some are in testing, but when looking out over time, assuming solar will accumulate at a rapid pace. It is an assumption. There is another slide coming up that talks about this in more detail.

**Yao Yin:** Why isn't residential solar considered from demand side versus supply side?

**James Gall:** Currently the customer controls that solar device and when it's producing. It belongs as a load component. In the event the utility offers incentives to change how they operate, that'd be a demand-side resource, but it could translate into a supply side resource.

**Yao Yin:** For other types of solar such as QF, do they belong to supply side? Yes.

**Andrew Rector (Slide #12):** What are your data sources for solar?

**Grant Forsyth:** Our own internal data from engineers that they collect. There is very little non-solar net metering on our system anymore. The data includes customer location and system size.

**Nikita Bankoti (Slide #11):** Again there is a lot of residential customer growth variation in 2021-2023, variation in GDP forecast, is it a good idea for this variability to be factored into the long-term forecast?

**Grant Forsyth:** I would need to think about this. Typically what happens with the medium term forecast, it is currently set up to mesh with the medium term forecast for the revenue model. The Company typically needs a medium term forecast to put into the revenue model. One of the frustrations with forecasters is how to handle this current COVID situation since it is atypical.

**Steve Johnson:** 10,000 watts in 2044. So that is a capacity factor of 15% on peak or on average? *On average, energy side rather than peak, approximately 10 aMW. It is on a spreadsheet.* I don't need precision just a general sense. Are you modeling solar to drop off before you get to your peak at 6 pm?

**Grant Forsyth:** It varies back and forth between 7 and 8 am to 5 to 6 pm where you see the most peaks occur.

**Steve Johnson:** Is solar making a small impact on peak? Yes.

**James Gall:** On winter, solar is making virtually no impact on peak, but maybe some peak shifting. In the summer, solar will reduce peak by about 60%. Subject to check, I think it is about 14% capacity factor on rooftop solar (DC rating not AC rating)

**Fred Heutte:** What method are you using? Are you using a simple logistic regression curve?

**Grant Forsyth:** It assumes an exponential growth function out to 2045. At some time we expect it to become logarithmic or some other type of term. It won't go on forever at this growth rate since we're just getting started.

**Fred Heutte:** Are you taking into consideration technology and cost reductions?

**Grant Forsyth:** That's why I'm assuming the size of growth due to technology developments and cost reductions. Allowing the size to grow and as they develop more solar, more ways to apply it.

**Fred Heutte:** I'm thinking about the experience curve. Can't project current trends to the longer term. Panel costs are not the majority of the costs now. Moved to telesales to drop costs. May drive the market more going forward.

**Grant Forsyth:** Two big uncertainties to model the longer term – solar and EVs.

**Fred Heutte:** We are encouraging utilities to look at higher EV penetration scenarios.

**Grant Forsyth:** We do have EV charging shape built into our future forecast.

**Fred Heutte:** How do you do rate design so we don't get a big hit?

**Grant Forsyth:** Where is policy going because that will shape a bunch of factors? Currently difficult to get a sense of where that's going.

**James Gall:** Commercial EVs?

**Grant Forsyth:** Residential EVs are highly correlated to growth in the commercial side. They follow each other. Implicit assumption that as EV are accumulated on the residential side, they'll accumulate on the commercial side.

**Andrew Rector:** Does it take into account EVs yet like buses? *No, it does not.*

**Yao Yin:** Is there a similar assumption between residential and commercial solar?

**Grant Forsyth:** Yes, but solar is still weighted heavily to the residential side, but I'm trying to maintain the correlation over time.

**James Gall:** Actually forecasting monthly, not hourly. We layer that into our models and will talk at a future TAC about how we are doing that.

**Slide #15:** At what point EV load starts to negate of solar? *The black dotted line. It bends up about 2040. When it does occur, it has a significant effect on load behavior.*

**Mike Morrison:** I don't think aMW is a useful metric in planning what we care about. I'm not sure of the relevance of aMW since capacity will occur over a couple of hours as opposed to over 24 hours. It shows magnitude.

**James Gall:** This is only the first slide. Coincident peak slide is coming up. Energy does matter – we look at peak and energy to meet both needs.

**Yao Yin:** For solar, we assume about 14% capacity factor, for EVs do we assume a certain percentage for solar?

**James Gall:** Yes, it's built into Grant's model, but I can't recall the exact factor. We look at the capability of a charge and the kilowatt per hour. We don't typically look at it that way so I don't have a factor right off.

**Yao Yin:** Do we assume certain hours EVs will get charged?

**Grant Forsyth:** Yes the profile tries to take that into effect.

**Yao Yin:** For the load forecast does this start monthly and peak hourly?

**Grant Forsyth:** Monthly and peak comes from Rendall's load profiles. Starts with hourly, converted to monthly. I may be misunderstanding your question.

**Yao Yin:** If we start with annual why do we convert to monthly?

**Grant Forsyth:** We are using monthly data to do peak load forecast so we have to convert it to monthly.

**James Gall:** For the IRP, we do use the monthly peak and energy in order to get to hourly. We look at winter/summer peak, annual energy.

**Yao Yin:** Another question regarding EVs, solar assumes about 14%, so do we have to assume a capacity factor for charging?

**James Gall:** There is a battery draw built into the model. 3,000 to 5,000 kWh per year depending on mileage. Great question.

**Grant Forsyth:** Assuming about 3,500 kWh per year from Rendall Farley's EV analysis submitted to the WUTC.

**Yao Yin:** Do you assume specific charging hours? *Yes, it's built into the load forecast and taken into account.*

**Andrew Rector:** Just for context, I have your EV plan in front of me with 3,153 kWh per year. *Sounds approximately right with what I entered.*

**Vlad Gutman-Britten:** What period of time is the trend your green line is using? *The whole time period.*

**Mike Morrison:** Is that a trend on individual years or 20-year moving average? Is that legal with a time series?

**Grant Forsyth:** I don't know if that's legal. I could try that. If I recall correctly, time series on a time series. It is heavily smoothed, but it's not being done nefariously. Can try it the other way certainly do it on the raw data.

**Mike Morrison (Slide #17):** So you got an increase of about 20% in cooling degree days, so people are going to buy more ACs with up to over 700 cooling degree days?

**Grant Forsyth:** This is my initial look, probably big implications for peak load; haven't done analysis for how I'd apply this to peak load. Additional adjustments will be needed. Multiple effects – income increasing, AC costs declining – leads to more purchase of ACs.

**Fred Heutte:** I had a little trouble on audio or dial in. On slide #18, double check of additive of slightly higher cooling degree days and quite a bit lower heating degree days. *Yes, that is the net effect through the regression model.* Agree with the approach of a 20-year moving average. Need at least 10 years and more is better. We can't go back too far or we lose the signal. Inter-year variability is very large. This seems to be in the right direction.

**Grant Forsyth:** Finally have analytically figured out how to shape that monthly. I appreciate the comments from everybody.

**Mike Morrison:** As far as conservation, I believe you go those numbers from your energy efficiency folks. We actually disagree with a lot of the numbers you got out of your energy efficiency group. The IPUC has asked Avista's conservation group to revisit their energy savings because IPUC disagrees with their estimates – very much over reporting.

**Grant Forsyth:** Fair enough. The information provided to me is what I have to work with.

**Mike Morrison:** Not criticizing you, but the information is dubious. There is very much over reporting in what energy efficiency has been doing.

**James Gall:** When we do capacity expansion modeling, we need an estimate of what our load looks like with our conservation. DSM programs compete against other resources. Based on what's picked (conservation) we adjust the black line up or down (slide 22).

**Mike Morrison:** Forecast based on average is that what we should be looking at.

**Grant Forsyth:** We do provide a band.

**Mike Morrison:** Are you really going to continue to be a winter peaking utility? I'm concerned with how you're doing your conservation programs (fuel switching).

**Grant Forsyth:** Yes, the conflict we face is the climate is changing, but the empirical data shows that winter is still the peak period. Summer is moving up and we need to be looking at an upper band.

**James Gall:** Grant is showing the average cold or hot day. In LOLP analysis, we simulate those bands. We typically see a wider band in the winter and typically a tighter band in the summer. This is used for loss of load based on probability of those ranges; what is the probability of one of these peaks aligning with an outage as such.

Substantial amount of fuel-switching from electric to natural gas. That peak is now removed. Both winter and summer are accounted for and optimized for.

**Fred Heutte (slide 29):** I have a comment about slide 25, but stay here. By eyeball it looks summer, but still winter mathematically. LOLP makes most sense, most important especially late summer – mid-July to mid-September.

**Deborah Reynolds:** As we're thinking about how energy efficiency will be incorporated into the load forecast, I've been thinking about taking the whole house efficiency and how that will affect summer load. Weatherization affects both summer and winter. Be thinking about how programs change over time. *Ok, will do that.*

**Yao Yin:** Winter and summer peak, have considered residential solar and EV conservation?

**Grant Forsyth:** Solar is not as direct and is embedded only to the extent it's in the historical data. EV effects are more direct. Solar does not have the same impacts on peak as EVs.

**James Gall:** We look at a peak credit to see how much it shaves peak. It was 2% in the last plan.

**Nikita Bankoti:** Do you include gas transportation customers?

**Grant Forsyth:** Yes, I do a forecast for transportation but not for the IRP because we're looking at core load.

**Tom Pardee (slide 32):** Transportation customers are tasked with getting their own transportation whereas we're responsible for the firm gas customers.

**Andrew Rector:** Is it economic things driving IHS's economic forecast in Roseburg?

**Grant Forsyth:** Yes, demographics. The only thing causing population growth is immigration or else it would be negative. I think they're suggesting that immigration is restrained. Natural birth rate is zero or negative there and only growth is from immigration which they think will be lower than usual. It was revised down before the shutdown.

**Andrew Rector:** Interesting context. Thanks.

**Nikita Bankoti (slide 46):** Negative industrial growth, is that from COVID?

**Grant Forsyth:** No that's from a longer-term secular trend. This was in last IRP too. It seems to be more of an acute problem in Washington than Idaho. Industrial companies are exiting or relocating more heavily weighted towards Washington. Sneaking suspicion that customers are going out of business or moving locations. Goes through Actual May 2020 numbers but there could be some longer-term impacts from COVID that may not appear for up to 24 months.

**James Gall:** What has the gas side seen from COVID?

**Grant Forsyth:** I'd say gas data weathered better than east side out of heating. Transportation customers being mostly industrial are a pretty good indicator of the economy. Wood products firms, lumber, have done better with housing. Gas line explosion caused some problem with switching from transport to firm schedules. The Air Force Base and Idaho continue to be a surprise in terms of robust growth.

**Deborah Reynolds:** One last question. Have you looked at how robust transportation conservation programs might impact gas transportation load and how much flexibility there is in terms of the rate they pay?

**Grant Forsyth:** That's a whopper. Many years ago, we had this conversation in Oregon, at the time with the low gas costs, it didn't make economic sense.

**Tom Pardee:** We can have Terrance speak about this on distribution if they are firm. If on transportation, we can cut them. We'll have an answer at the next TAC.

**Deborah Reynolds:** Legislation passed that you have to get ALL and that might include transportation customers.

**Shawn Bonfield:** They don't pay into the tariff.

**Deborah Reynolds:** I agree which is why I need you guys to do some work.





***2021 Electric Integrated Resource Plan***  
**Technical Advisory Committee Meeting No. 3 Agenda**  
**Tuesday, September 29, 2020**  
**Virtual Meeting**

<b>Topic</b>	<b>Time</b>	<b>Staff</b>
Introductions	9:00	Lyons
IRP Transmission Planning Studies	9:15	Spratt
Break	10:15	
Distribution Planning within the IRP	10:30	Fisher
Lunch	11:30	
Demand Response Potential Assessment	12:30	AEG
Break	1:30	
Conservation Potential Assessment	1:45	AEG
Electric Market Forecasts	2:45	Gall
Portfolio Scenarios	3:30	Lyons
Adjourn	4:00	

→ [Join Skype Meeting](#)

Trouble Joining? [Try Skype Web App](#)

**Join by phone**

[509-495-7222](#) (Spokane)

English (United States)

[Find a local number](#)

Conference ID: 67816

[Forgot your dial-in PIN?](#) | [Help](#)



# 2021 Electric IRP TAC Introductions and IRP Process Updates

John Lyons, Ph.D.  
Third Technical Advisory Committee Meeting  
September 29, 2020

# Updated Meeting Guidelines

- Electric IRP team still working remotely, available by email and phone for questions and comments
- Some processes are taking longer remotely
- Virtual IRP meetings until back in the office and able to hold large group meetings
- Joint Avista IRP page for gas and electric:  
<https://www.myavista.com/about-us/integrated-resource-planning>

# Virtual TAC Meeting Reminders

- Please mute mics unless speaking or asking a question
- Use the Skype chat box to write questions or comments or let us know you would like to say something
- Respect the pause
- Please try not to speak over the presenter or a speaker who is voicing a question or thought
- Remember to state your name before speaking for the note taker
- This is a public advisory meeting – presentations and comments will be recorded and documented

# Integrated Resource Planning

- Required by Idaho and Washington\* every other year
- Guides resource strategy over the next twenty + years
- Current and projected load & resource position
- Resource strategies under different future policies
  - Resource choices
  - Conservation measures and programs
  - Transmission and distribution integration for electric
  - Gas distribution planning
  - Gas and electric market price forecasts
- Scenarios for uncertain future events and issues
- Key dates for modeling and IRP development are available in the Work Plans

# Technical Advisory Committee

- The public process piece of the IRP – input on what to study, how to study, and review of assumptions and results
- Wide range of participants involved in all or parts of the process
  - Ask questions
  - Help with soliciting new members
- Open forum while balancing need to get through all of the topics
- Welcome requests for studies or different assumptions.
  - Time or resources may limit the number or type of studies
  - Earlier study requests allow us to be more accommodating
  - **August 1, 2020** was the electric study request deadline
- Planning teams are available by email or phone for questions or comments between the TAC meetings

# 2021 Electric IRP TAC Schedule

- TAC 1: Thursday, June 18, 2020
- TAC 2: Thursday, August 6, 2020 (Joint with Natural Gas TAC)
- TAC 2.5: Tuesday, August 18, 2020 Economic and Load Forecast
- **TAC 3: Tuesday, September 29, 2020**
- TAC 4: Tuesday, November 17, 2020
- TAC 5: Thursday, January 21, 2021
- Public Outreach Meeting: February 2021
- TAC agendas, presentations, meeting minutes and IRP files available at:

<https://myavista.com/about-us/integrated-resource-planning>

# Process Updates

## **IRP data available on the web site:**

- Avista Resource Emissions Summary
- Load Forecast
- CPA Measures
- Avista 2020 Electric CPA – Summary and IRP Inputs
- Home Electrification Conversions
- Named Populations
- Natural Gas Prices
- Social Cost of Carbon



# Today's TAC Agenda

- 9:00 Introductions, Lyons
- 9:15 IRP Transmission Planning Studies, Spratt
- 10:15 Break
- 10:30 Distribution Planning within the IRP, Fisher
- 11:30 Lunch
- 12:30 Demand Response Potential Assessment, AEG
- 1:30 Break
- 1:45 Conservation Potential Assessment, AEG
- 2:45 Electric Market Forecasts, Gall
- 3:30 Portfolio Scenarios, Lyons
- 4:00 Adjourn



# Integrated Resource Plan (IRP) Transmission Planning Studies

Dean Spratt, Transmission Planning  
Third Technical Advisory Committee Meeting  
September 29, 2020

# FERC Standards of Conduct

Non-public transmission information can not be shared with Avista Merchant Function employees

There are Avista Merchant Function employees attending today

We will not be sharing any non-public transmission information. Avista's OASIS is where this information is made public

# Agenda

- Introduction to Avista System Planning
  - Useful information about Transmission Planning
  - Recent Avista projects
- Generation Interconnection Study Process
  - Integrated Resource Plan (IRP) Requests
  - Large Generation Interconnection Queue

# Introduction to Avista System Planning

Avista's System Planning Group includes:

- Asset Performance and Management
- Distribution Planning
- Transmission Planning
  - Focus on reliable electric service
    - Federal, regional, and state compliance
    - Regional system coordination
  - Provide transmission service and system analysis
    - Planned load growth and changing generation dispatch
    - Interconnection of any type of generation or load
      - We are ambivalent about type (must perform though)

# Information About Transmission Planning

- We care about the Bulk Electric System (BES)
  - Our 115 kV and 230 kV facilities (>100 kV)
- We identify issues where the Avista BES won't reliably deliver power to our customers
- Then put together plans to fix it
  - “Corrective Action Plans”
  - Mandated and described in NERC TPL-001-4
- We live in the world of NERC Mandatory Standards
  - Energy Policy Act of 2005

# TPL-001-4

- Describes outage conditions we must study
  - P0: everything online and working
  - P1: single facility outages, like a transformer
  - P2, P4, P5 & P7: multiple facility outages
  - P3 & P6: overlapping combination of two facilities

Standard TPL-001-4 — Transmission System Planning Performance Requirements

Table 1 – Steady State & Stability Performance Planning Events							
<b>Steady State &amp; Stability:</b>							
a. The System shall remain stable. Cascading and uncontrolled islanding shall not occur.							
b. Consequential Load Loss as well as generation loss is acceptable as a consequence of any event excluding P0.							
c. Simulate the removal of all elements that Protection Systems and other controls are expected to automatically disconnect for each event.							
d. Simulate Normal Clearing unless otherwise specified.							
e. Planned System adjustments such as Transmission configuration changes and re-dispatch of generation are allowed if such adjustments are executable within the time duration applicable to the Facility Ratings.							
<b>Steady State Only:</b>							
f. Applicable Facility Ratings shall not be exceeded.							
g. System steady state voltages and post-Contingency voltage deviations shall be within acceptable limits as established by the Planning Coordinator and the Transmission Planner.							
h. Planning event P0 is applicable to steady state only.							
i. The response of voltage sensitive Load that is disconnected from the System by end-user equipment associated with an event shall not be used to meet steady state performance requirements.							
<b>Stability Only:</b>							
j. Transient voltage response shall be within acceptable limits established by the Planning Coordinator and the Transmission Planner.							
Category	Initial Condition	Event <sup>1</sup>	Fault Type <sup>2</sup>	BES Level <sup>3</sup>	Interruption of Firm Transmission Service Allowed <sup>4</sup>	Non-Consequential Load Loss Allowed	
<b>P0</b> No Contingency	Normal System	None	N/A	EHV, HV	No	No	
<b>P1</b> Single Contingency	Normal System	Loss of one of the following: 1. Generator 2. Transmission Circuit 3. Transformer <sup>5</sup> 4. Shunt Device <sup>6</sup>	3Ø	EHV, HV	No <sup>9</sup>	No <sup>12</sup>	
		5. Single Pole of a DC line	SLG				
<b>P2</b> Single Contingency	Normal System	1. Opening of a line section w/o a fault <sup>7</sup>	N/A	EHV, HV	No <sup>9</sup>	No <sup>12</sup>	
		2. Bus Section Fault	SLG	EHV	No <sup>9</sup>	No	
		3. Internal Breaker Fault <sup>8</sup> (non-Bus-tie Breaker)	SLG	HV	Yes	Yes	Yes
		4. Internal Breaker Fault (Bus-tie Breaker) <sup>8</sup>	SLG	EHV	No <sup>9</sup>	No	No

Standard TPL-001-4 — Transmission System Planning Performance Requirements

Category	Initial Condition	Event <sup>1</sup>	Fault Type <sup>2</sup>	BES Level <sup>3</sup>	Interruption of Firm Transmission Service Allowed <sup>4</sup>
<b>P3</b> Multiple Contingency	Loss of generator unit followed by System adjustments <sup>9</sup>	Loss of one of the following: 1. Generator 2. Transmission Circuit 3. Transformer <sup>5</sup> 4. Shunt Device <sup>6</sup>	3Ø	EHV, HV	No <sup>9</sup>
		5. Single pole of a DC line	SLG		
<b>P4</b> Multiple Contingency (Fault plus stuck breaker <sup>10</sup> )	Normal System	Loss of multiple elements caused by a stuck breaker <sup>10</sup> (non-Bus-tie Breaker) attempting to clear a Fault on one of the following: 1. Generator 2. Transmission Circuit 3. Transformer <sup>5</sup> 4. Shunt Device <sup>6</sup> 5. Bus Section	SLG	EHV	No <sup>9</sup>
		6. Loss of multiple elements caused by a stuck breaker <sup>10</sup> (Bus-tie Breaker) attempting to clear a Fault on the associated bus	SLG	HV	Yes
<b>P5</b> Multiple Contingency (Fault plus relay failure to operate)	Normal System	Delayed Fault Clearing due to the failure of a non-redundant relay <sup>11</sup> protecting the Faulted element to operate as designed, for one of the following: 1. Generator 2. Transmission Circuit 3. Transformer <sup>5</sup> 4. Shunt Device <sup>6</sup> 5. Bus Section	SLG	EHV	No <sup>9</sup>
			SLG	HV	Yes
<b>P6</b> Multiple Contingency (Two overlapping singles)	Loss of one of the following followed by System adjustments <sup>9</sup>	Loss of one of the following: 1. Transmission Circuit 2. Transformer <sup>5</sup> 3. Shunt Device <sup>6</sup>	3Ø	EHV, HV	Yes
		4. Single pole of a DC line	SLG		

## TPL-001-4, cont.

- A couple of NERC directives for the above faults
  - “The System shall remain stable”
    - Cascading and uncontrolled islanding shall not occur
  - “Applicable Facility Ratings shall not be exceeded”
    - Equipment ratings, voltage, fault duty, etc
  - “An objective of the planning process is to minimize the likelihood and magnitude of Non-Consequential Load Loss following planning events”



# Two Approaches to Reliability Issues

- Transmission Operations (TO) are guided by significantly different standards than Transmission Planning (TP).
- TO standards provide *flexibility* that TP standards do not allow
  - Operators can push system limits to **SAVE** the interconnected system
    - Shed load, overload equipment, etc – all short term
    - The planned system should give them the tools to do this
    - Standards continue to define this balance

# Standards are a Roadmap

Changes in equipment, analysis tools, experience, and expectations impact Avista's study process and results

**WSCC DISTURBANCE-PERFORMANCE TABLE  
OF ALLOWABLE EFFECT ON OTHER SYSTEMS<sup>(1)</sup>**

Performance Level	Disturbance(2) Initiated By: No Fault 3 Ø Fault With Normal Clearing SLG Fault With Delayed Clearing DC Disturbance (3)	Transient Voltage Dip Criteria	Minimum Transient Frequency	Post Transient Voltage Deviation	Loading Within Emergency Ratings	Damping
		(4)(5)(6)	(4)(5)	(4)(5)(6)(7)		
A	Generator One Circuit One Transformer DC Monopole (8)	Max V Dip - 25%  Max Duration of V Dip Exceeding 20% - 20 cycles	59.6 hz  Duration of f Below 59.6 hz - 6 cycles	5%	Yes	>0
B	Bus Section	Max V Dip - 30%  Max Duration of V Dip Exceeding 20% - 20 cycles	59.4 hz  Duration of f Below 59.4 hz - 6 cycles	5%	Yes	>0
C	Two Generators Two Circuits DC Bipole (8)	Max V Dip - 30%  Max Duration of V Dip Exceeding 20% - 40 cycles	59.0 hz  Duration of f Below 59.0 hz - 6 cycles	10%	Yes	>0
D	Three or More circuits on ROW Entire Substation Entire Plant Including Switchyard	Max V Dip - 30%  Max Duration of V Dip Exceeding 20% - 60 cycles	58.1 hz  Duration of f Below 58.1 hz - 6 cycles	10%	No	≥0

# Recent Transmission Projects

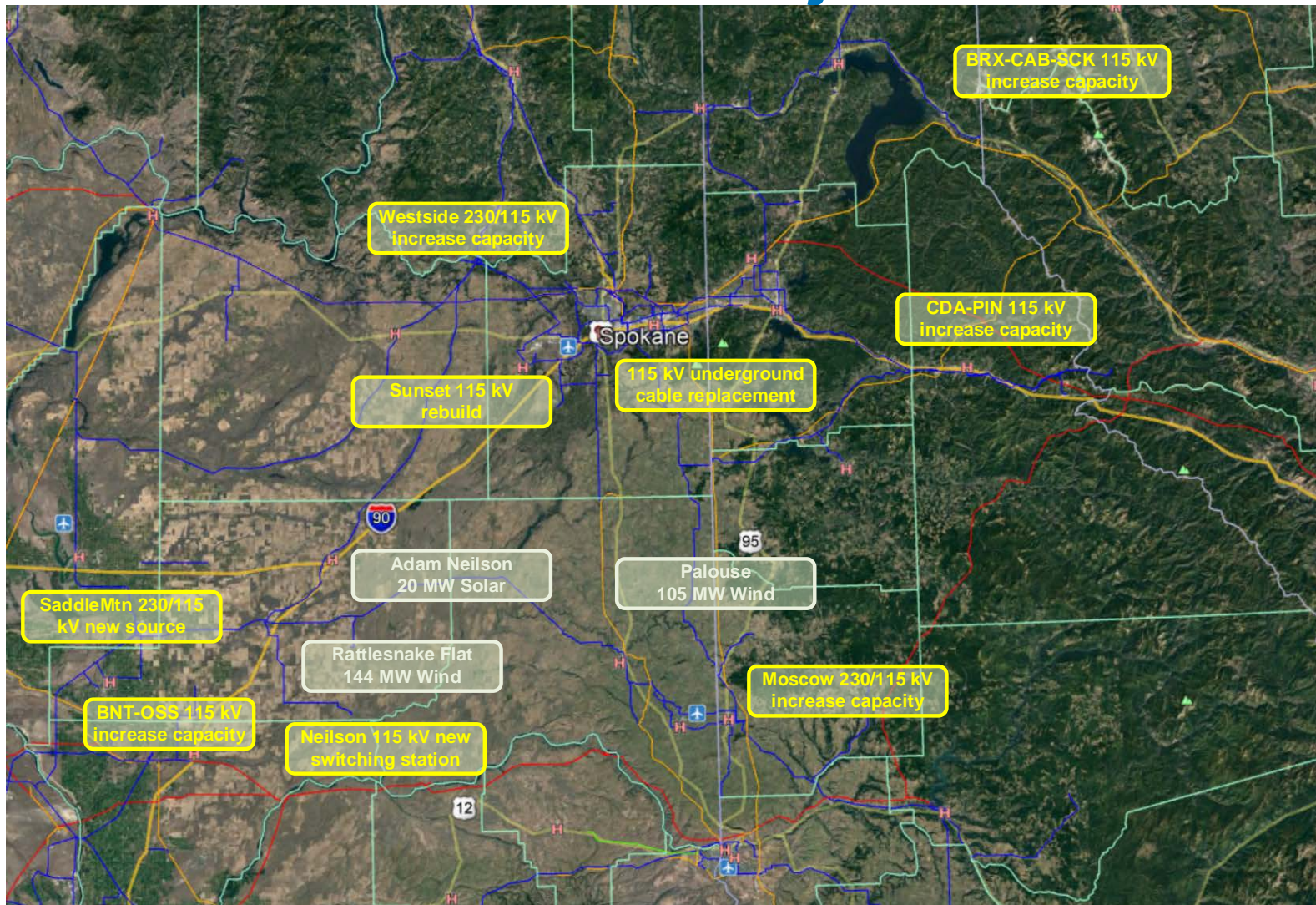

# Non Wire Solutions are Evaluated

- We are documenting this with more clarity
- Non-wire options require robust wires to perform
  - Avista is working on the transmission fundamentals

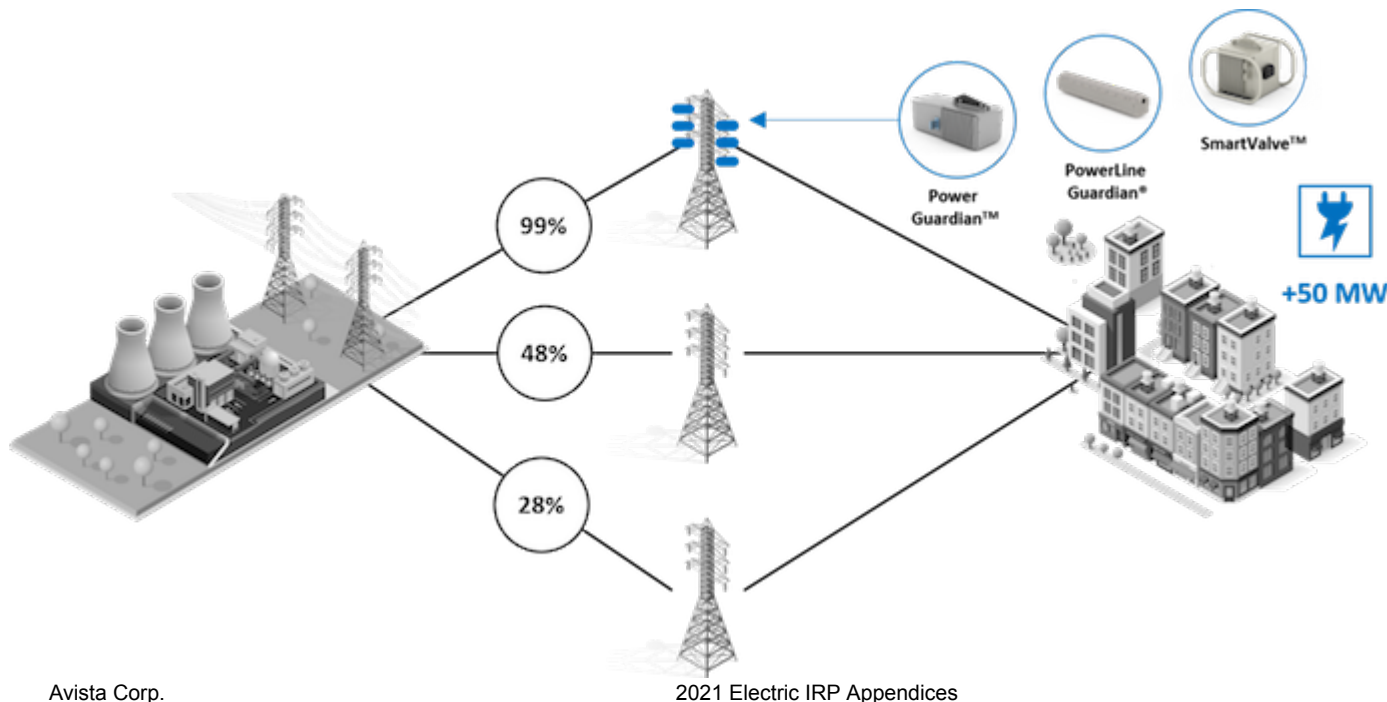

# Evaluated Batteries for T-1-1

- TPL-001-4 ~ T-1-1 for long lead equipment
  - Double transformer outages
    - Shawnee 230/115 kV outage followed by a:
      - Concurrent outage of Moscow 230/115 kV
  - Could we mitigate performance issues with storage?
    - Yes...but...
      - We would need a 125 MW battery
        - » Charge is 8 hours, discharge for 12 to 16 hours (outage is weeks to months)
      - A third transformer is a better solution
        - » Robust performance and much less \$\$\$\$

Line	Description	Need-By	Deliver-To	Unit	Quantity	Qty Delivered	Qty Cancelled	Open Quantity	Price	Amount (USD)
1	250/280MVA, 230-115-13.8kV, three phase auto transformer.	10/03/2018 12:51:34	One Time Ship To	Each	1	1	0	0	2397826 USD	2,397,826.00
2	SFRA Testing at factory and field	10/03/2018 12:51:34	One Time Ship To	Each	1	1	0	0	5400 USD	5,400.00
									<b>Total</b>	<b>2,403,226.00</b>

Avista Corp. 2021 Electric IRP Appendices

Requisitions: Requisitions >  
Requisition 162964

Description **M08 - Westide 250/280MVA, 230-115-13.8kV, three phase auto transformer.**  
 Created By **Wilson, Barnes Scott (Scott)**  
 Creation Date **12/06/2017 12:49:35**  
 Deliver-To **One Time Ship To**  
 Justification **This is the second transformer associated with the Westside Substation rebuild.**

Status [Approved](#)  
 Change History **No**  
 Urgent Requisition **No**  
 Attachment [View](#)  
 Note to Buyer **Quote attached. Bid evaluation sheet pre Shelly Campbell**

## Details

# Generation Interconnection Study Process

## Process for Generation Requests

- Two sources:
  - External developers
    - Enter via the OATT
  - Internal IRP requests
    - Feasibility Lite Study...then OATT
      - AVA Merchant MUST follow the OATT just like external parties
- Typical process:
  - Hold a scoping meeting to discuss particulars
  - Outline a study plan
  - Augment WECC approved cases for our studies
  - Analyze the system against the standards
  - Publish our findings and recommendations

# Interconnection Study Timeline

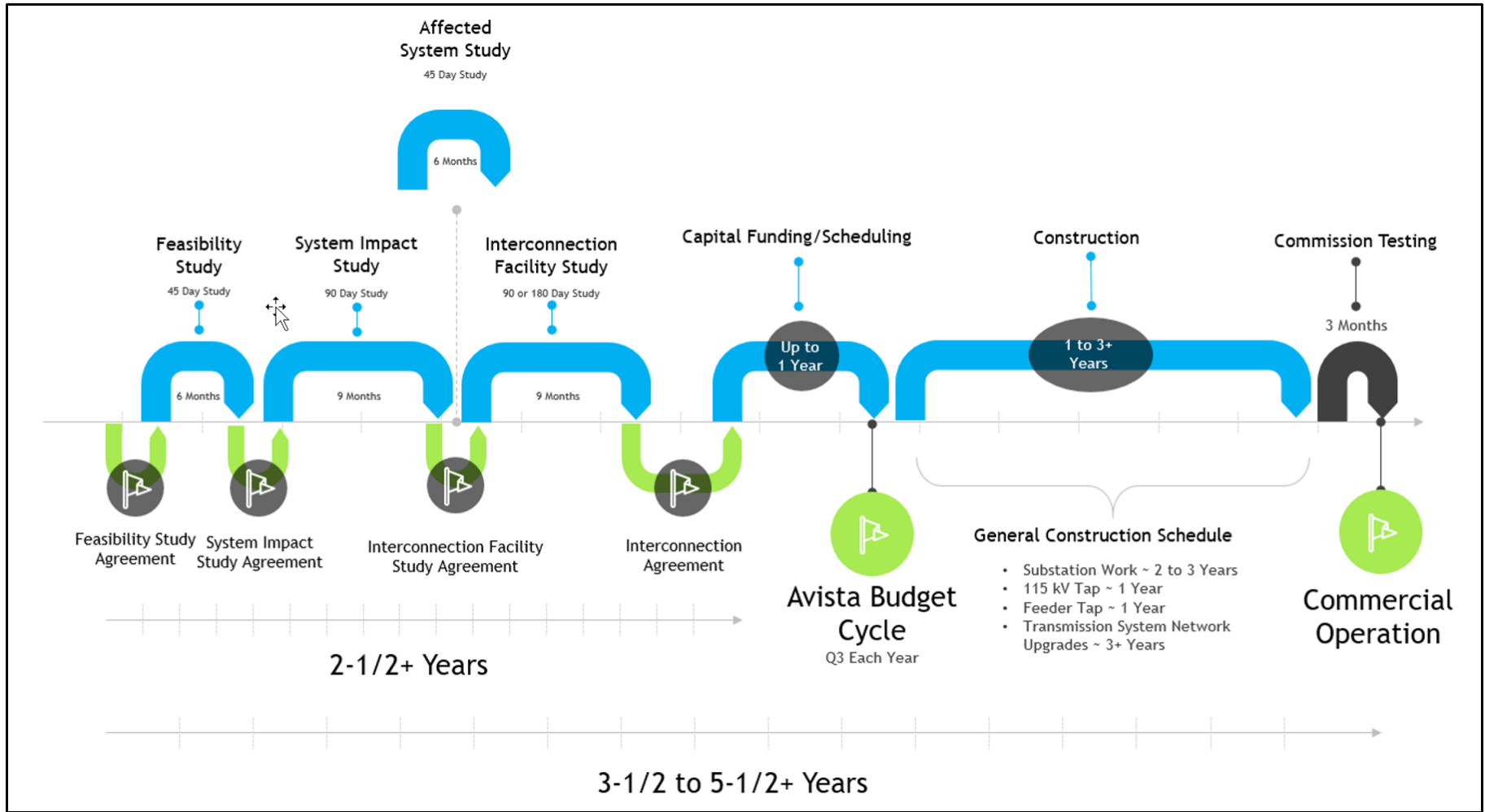

# Current Interconnection Queue

Generator Interconnection Applications								
Proj #	Date of Request	Status of Request	Service Type	Max Summer output	Max Winter output	Total (MW)	Projected In-Service Date	Type of facility
17	3/6/2009	Operational	ER	100	100	100.00	6/1/2011	Wind
46	10/6/2015	LGIA	NR	126	126	126.00		Wind
52	2/8/2017	LGIA	NR	100	100	100.00		Solar
53	4/11/2017	Operational	NR	19.2	19.2	19.2	12/15/2018	Solar
59	5/23/2018	SIS	NR/ER	116	116	116.00	6/1/2021	Solar & Storage
60	6/4/2018	IFS	ER	150	150	150.00	12/15/2022	Solar & Storage
61	6/4/2018	Withdrawn	NR	20	20	20.00	11/15/2019	Solar
62	6/8/2018	FS	NR/ER	123.2	123.2	123.20	11/30/2021	Wind
63	6/8/2018	FS	NR/ER	26	26	26.00	2/28/2023	Hydro
66	7/10/2018	FS	NR	71	71	71.00	7/1/2023	Wood Waste
67	8/27/2018	FS	NR/ER	80	80	80.00	6/30/2023	Solar
68	9/20/2018	FS	ER	750	750	750.00		Wind
69	9/20/2018	FS	ER	750	750	750.00		Wind
70	8/31/2018	SIS	NR	2.5	2.5	2.50	1/1/2019	Energy Storage - Battery
71	10/4/2018	FS	NR	7	7	7.00	8/15/2020	Solar
72	10/9/2018	FS	NR/ER	80	80	80.00	6/30/2021	Solar
73	10/12/2018	FS	NR/ER	100	100	100.00	6/30/2020	Solar
74	11/16/2018	SIS	NR/ER	0.1	0.1	0.10	1/15/2019	Energy Storage - Battery
76	11/27/2018	FS	NR/ER	200	200	200.00	12/31/2020	Solar
77	12/4/2018	FS	NR/ER	5	5	5.00	12/31/2020	Solar
79	12/4/2018	FS	NR/ER	5	5	5.00	6/30/2020	Solar



# Current Queue, continued

Generator Interconnection Applications								
Proj #	Date of Request	Status of Request	Service Type	Max Summer output	Max Winter output	Total (MW)	Projected In-Service Date	Type of facility
80	12/17/2018	FS	NR/ER	19	19	19.00	6/30/2020	Solar
81	12/18/2018	FS	NR/ER	94	94	94.00	6/30/2020	Solar
82	2/20/2019	FS	ER	600	600	600.00	12/31/2021	Wind
83	3/27/2019	FS	ER	300	300	300.15	10/31/2022	Wind
84	4/17/2019	FS	NR/ER	5	5	5.00	8/31/2020	Solar
85	4/17/2019	FS	NR/ER	5	5	5.00	8/31/2020	Solar
86	5/29/2019	New	NR/ER	20	20	20.00	12/31/2022	Solar
87	6/17/2019	New	NR	5	5	5.00	8/31/2021	Solar
88	6/17/2019	New	NR	5	5	5.00	8/31/2021	Solar
89	6/17/2019	New	NR	5	5	5.00	8/31/2021	Solar
90	6/17/2019	New	NR	5	5	5.00	8/31/2021	Solar
91	6/17/2019	New	NR	5	5	5.00	8/31/2021	Solar
92	6/17/2019	New	NR	5	5	5.00	8/31/2021	Solar
93	6/17/2019	New	NR	5	5	5.00	8/31/2021	Solar
94	6/17/2019	New	NR	5	5	5.00	8/31/2021	Solar
95	6/20/2019	New	NR/ER	600	600	600.00	12/1/2022	Wind
96	6/20/2019	New	NR/ER	400	400	400.00	12/1/2022	Wind
97	6/24/2019	FS	NR/ER	150	150	150.00	12/31/2021	Solar & Storage
98	8/29/2019	New	NR/ER	80	80	80.00	12/1/2023	Solar & Storage
99	9/6/2019	New	NR	200	200	200.00	12/31/2021	Solar & Storage
100	9/27/2019	New	NR/ER	100	100	100.00	12/31/2021	Solar & Storage
101	10/22/2019	FS	NR/ER	500	500	500.00	9/1/2024	Wind & Storage
102	11/5/2019	New	NR/ER	200	200	200.00	11/30/2022	Solar & Storage
103	12/10/2019	New	NR	19.25	19.25	19.25	3/31/2021	Solar
104	3/2/2020	New	NR/ER	120	120	120.00	12/31/2023	Wind

# 2021 IRP Transmission Cost Estimates

Assume anti-islanding scheme, but no RAS

Station	Request (MW)	POI Voltage	Cost Estimate (\$ million)
Kootenai County (GF)	100	230 kV	4
Kootenai County (GF)	200/300	230 kV	80-100
Rathdrum	25/50/100	115 kV	<1
Rathdrum	200	115 kV	55
Rathdrum	50/100	230 kV	<1
Rathdrum	200	230 kV	60
Benewah	100/200	230 kV	<1
Tokio	50/100	115	<1, 20
Othello/Lind	50/100/200	115 kV	Queue Issues
Lewiston/Clarkston	100/200	230 kV	<1
Northeast	10	115 kV	<1
Kettle Falls	12	115 kV	<1
Kettle Falls	24/100/124	115 kV	<20
Long Lake	68	115 kV	33
Monroe Street	80	115 kV	2
Post Falls	10	115 kV	<1
Cabinet Gorge	110	230 kV	<14

2021 Electric IRP Appendices

□ Preliminary estimates are given as -25% to +75%

# Monroe Street: 80 MW

Requires the Metro Rebuild Project be completed

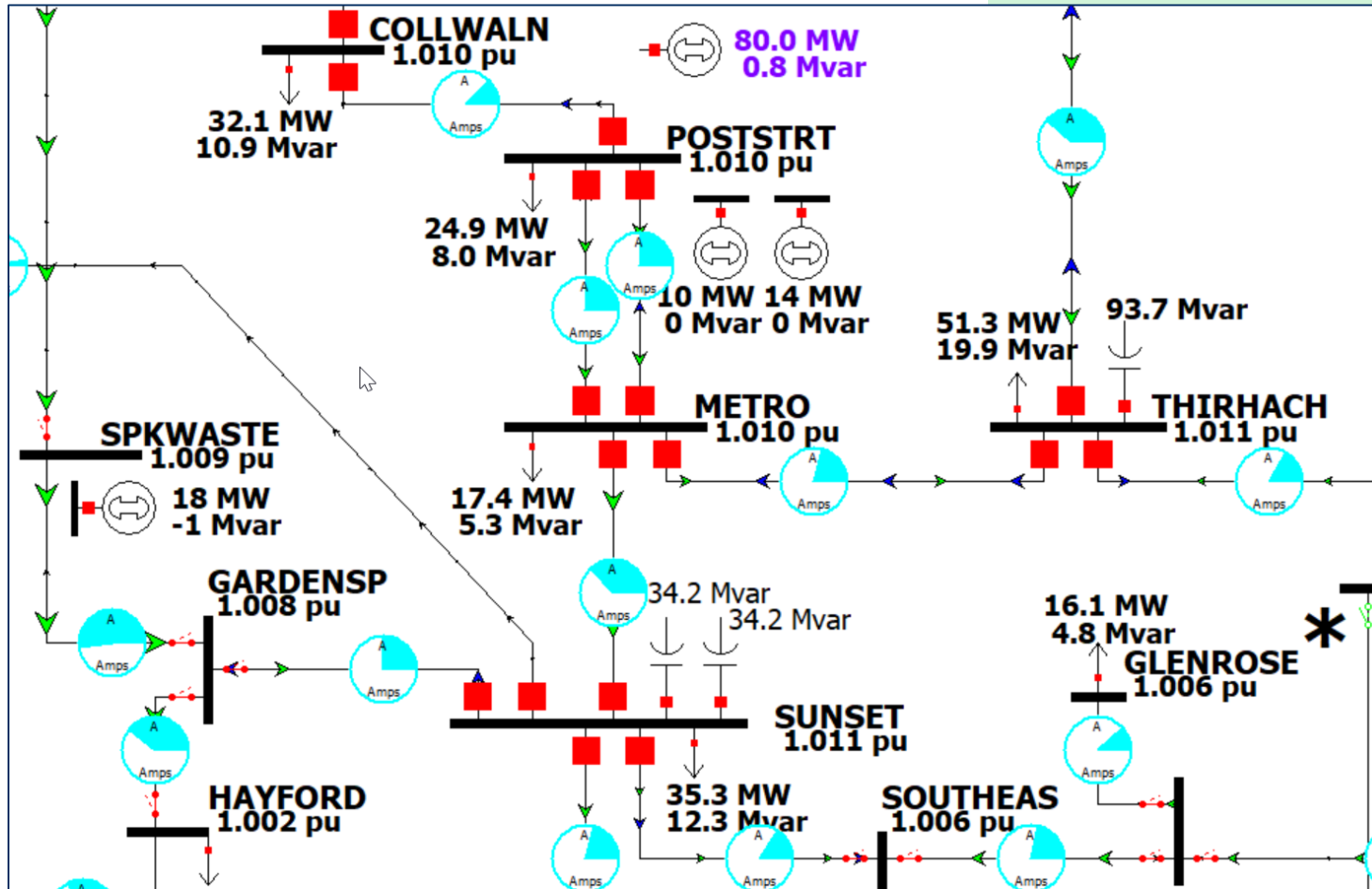

# Post Falls: 10 MW to 20 MW

Interconnection only

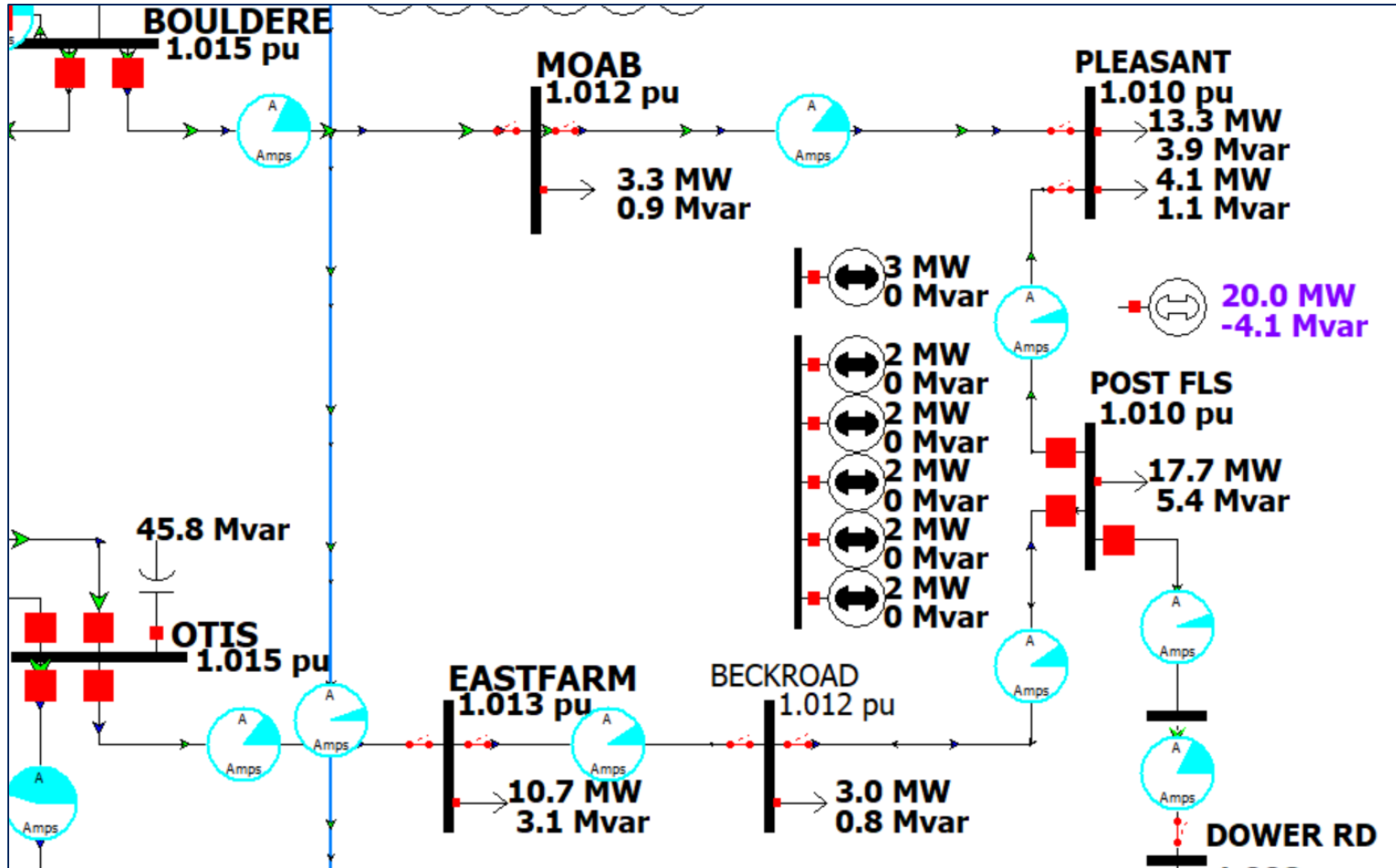

# Questions?

**Avista OASIS link:**  
**<http://www.oasis.oati.com/avat/index.html>**



# Distribution Resource Planning

Damon Fisher, System Planning  
Third Technical Advisory Committee Meeting  
September 29, 2020

# Goals of Electric Distribution Planning

- Ensure electric distribution infrastructure to serve customers now and in the future with a focus on:
  - Safety
  - Reliability
  - Capacity
  - Efficiency
  - Level of service
  - Operational flexibility
  - Corporate/Regulatory goals
  - Affordability



# Distribution Resource Planning

- Washington House Bill 1126 (passed 2019)
  - <https://app.leg.wa.gov/RCW/default.aspx?cite=19.280.100>
  - 10-Year Plan
  - DER's and Non-Wire Alternatives
  - IRP Resource Needs
  - Temporal and spatial planning
  - Temporal and spatial value
  - Probabilistic analysis (Pessimistic, Optimistic)
  - Open Planning



# Primary Goal of Distribution Resource Plan

- Where possible, solve distribution grid deficiencies using distributed energy resources (DER) that also contribute to system resource needs as identified in the Integrated Resource Plan.

# Can IRP resource needs and distribution “fixes” be aligned? Certainly.

- Not without challenges.
  - Temporal need
  - Grid operation and flexibility
  - Resource adequacy- a new distribution definition?
  - System Protection

# Typical Distribution System Deficiencies

- Low Voltage
- Capacity (Substation/Feeder)
- Asset Condition
- Contingency Switching Limits

# What are DER's? – Distribution's Perspective

- Anything that can reduce demand or support voltage

## **Real**

Targeted Energy Efficiency

Targeted Demand Response

## **Apparent**

Storage (Load shifting)

Generation (Load service)

# How Do DER's Get Implemented?

- Three Paths-
  1. Retail/Commercial Customer driven. Customers install DER's on their side of the meter for unknown reasons.
  2. The second way would be 3<sup>rd</sup> party grid connections (utility scale). We have a few requests in the queue and a 20MW installation in Lind Washington. These can cause grid challenges.
  3. The third way is utility-driven targeted DER's to solve grid issues on either side of the meter. Incentivized #1 and #2 above.

# System Resources vs. Feeder Demand

System loads at various levels

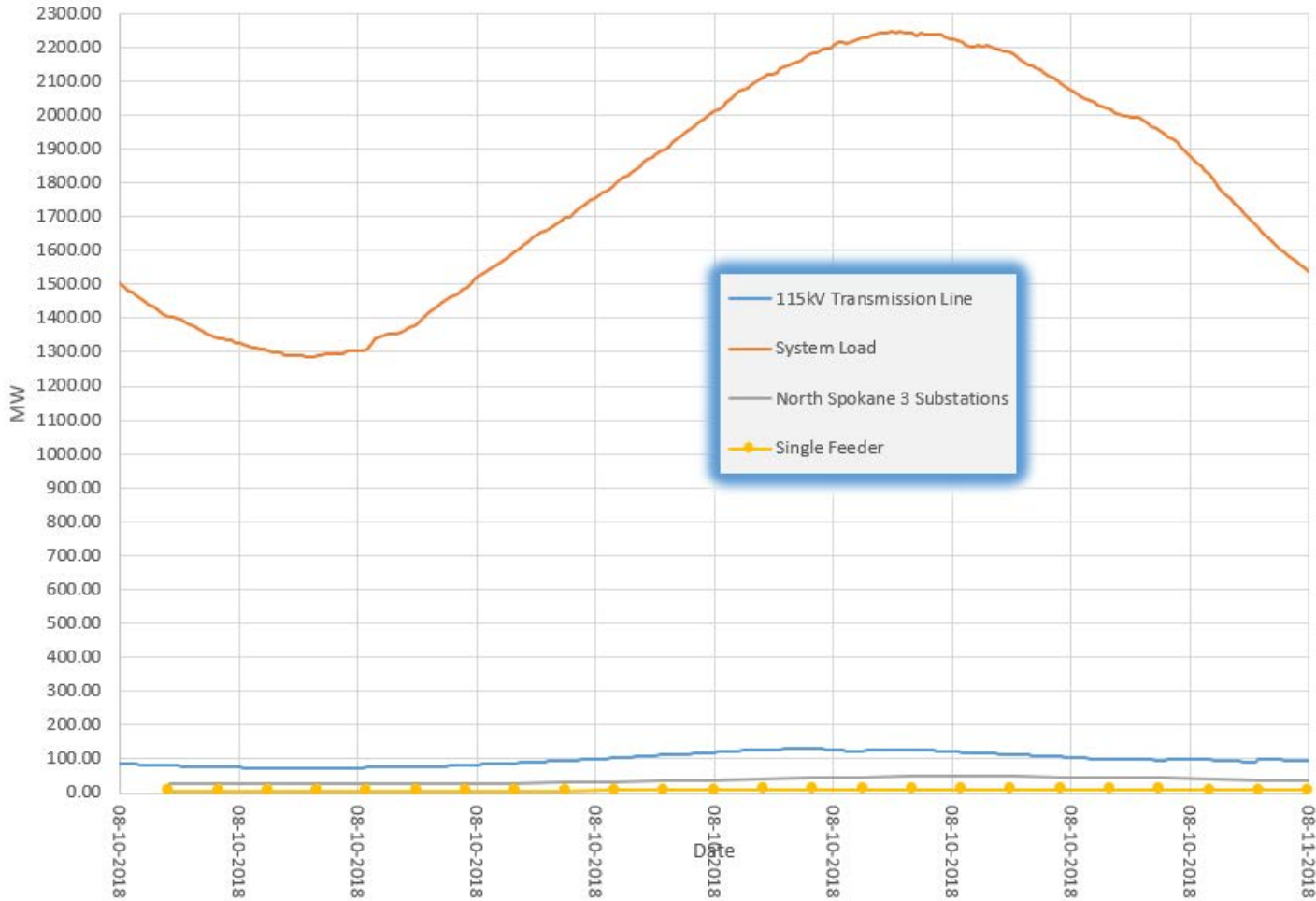

# System Resources vs. Feeder Demand

System loads at various levels

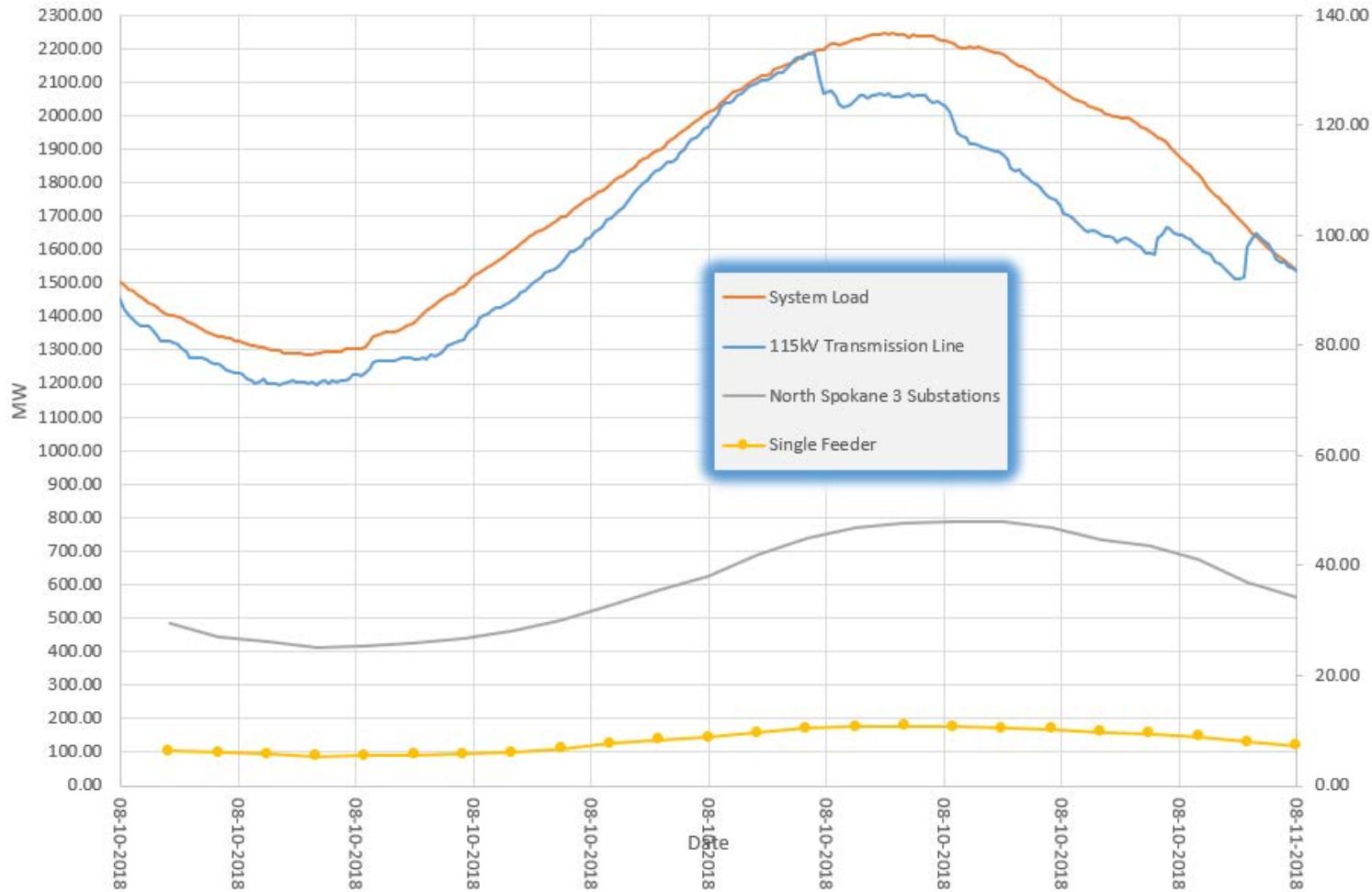

# It Is All About Curves

- The ideal curve-

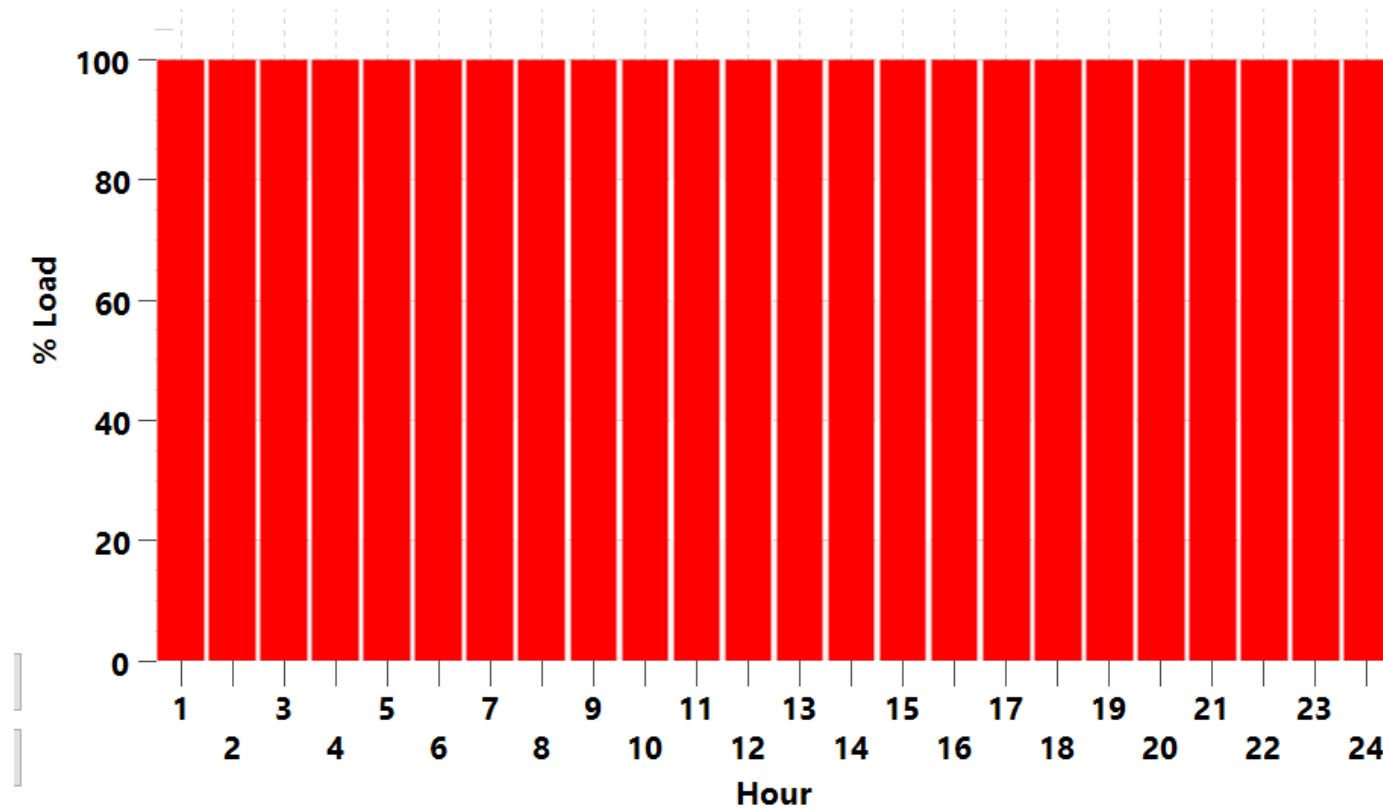



# It is all about curves

- A real curve (not ideal)-

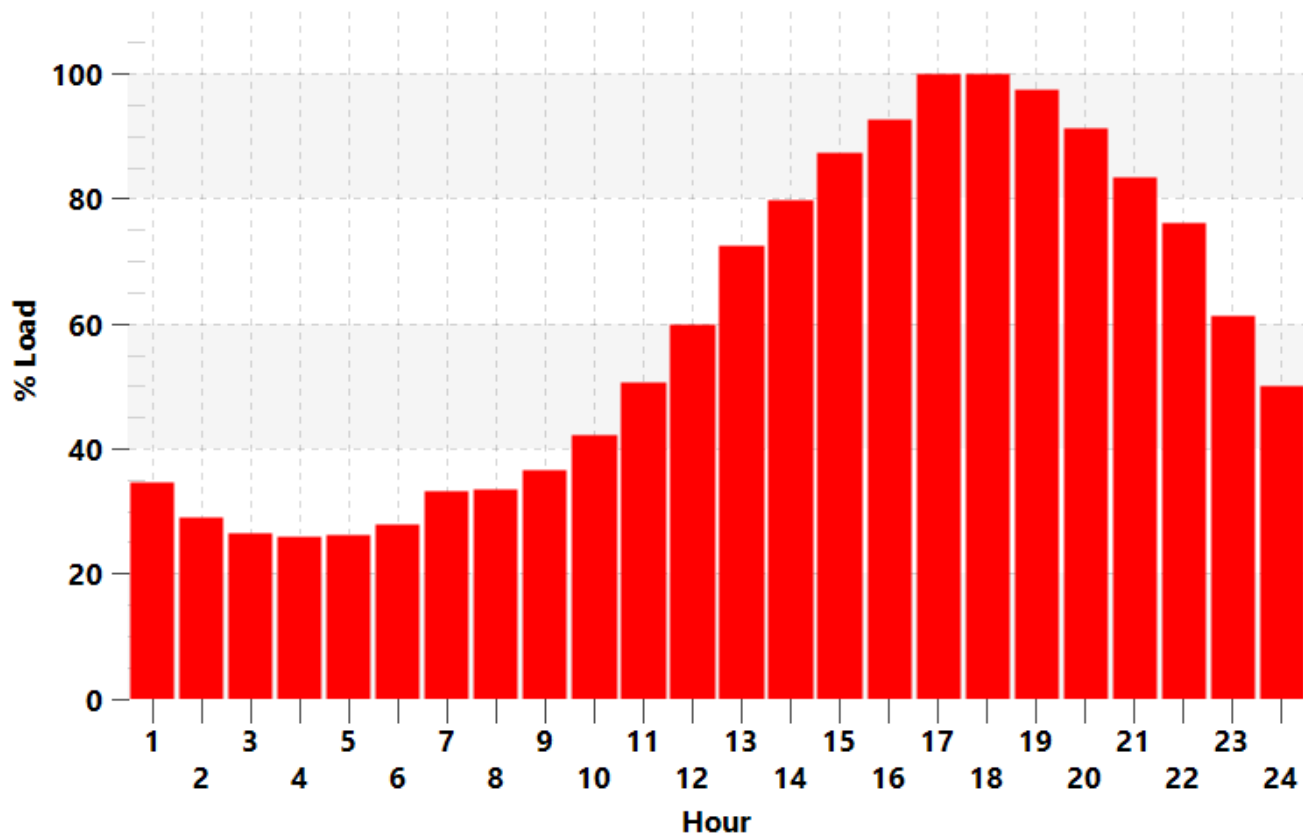

# Can We Fix Curves with PV? Community Solar – Summer

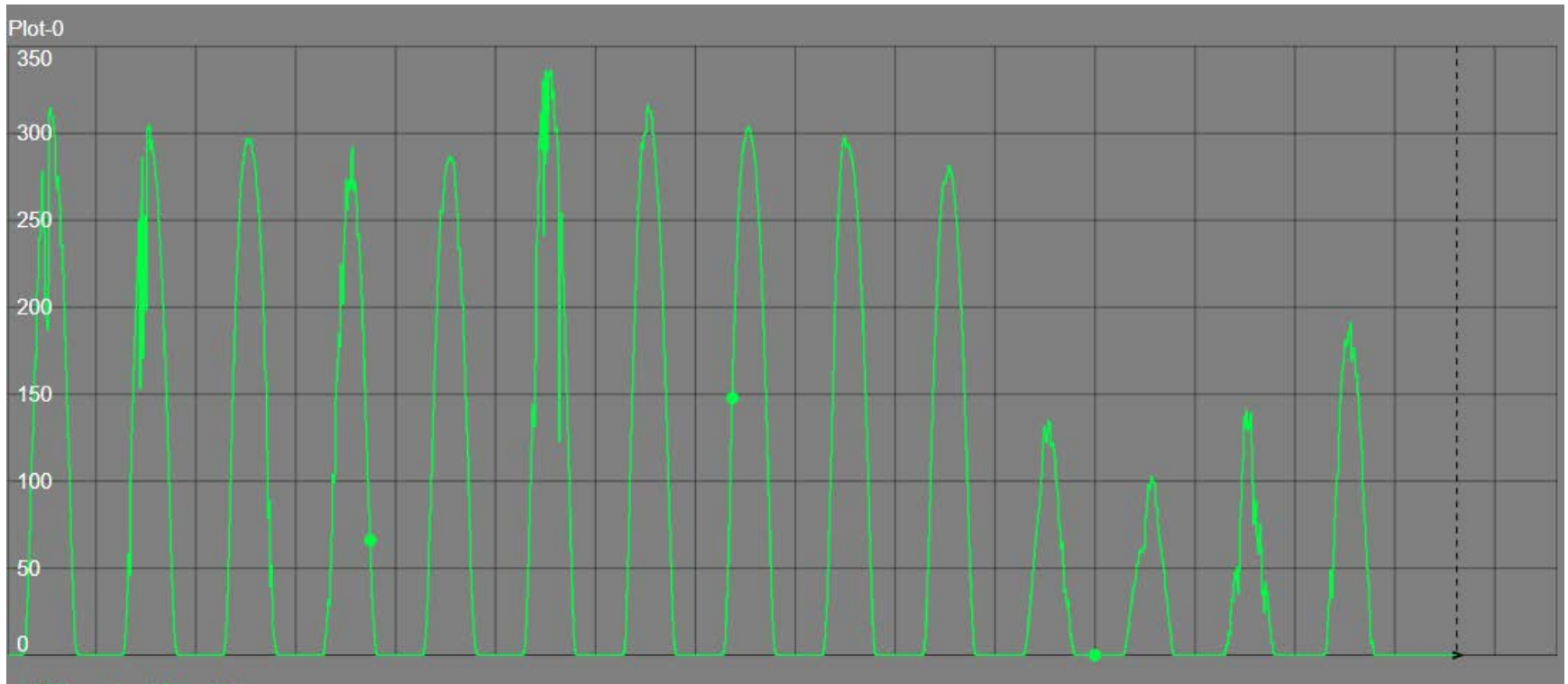

# Can We Fix Curves with PV? Community Solar – Winter

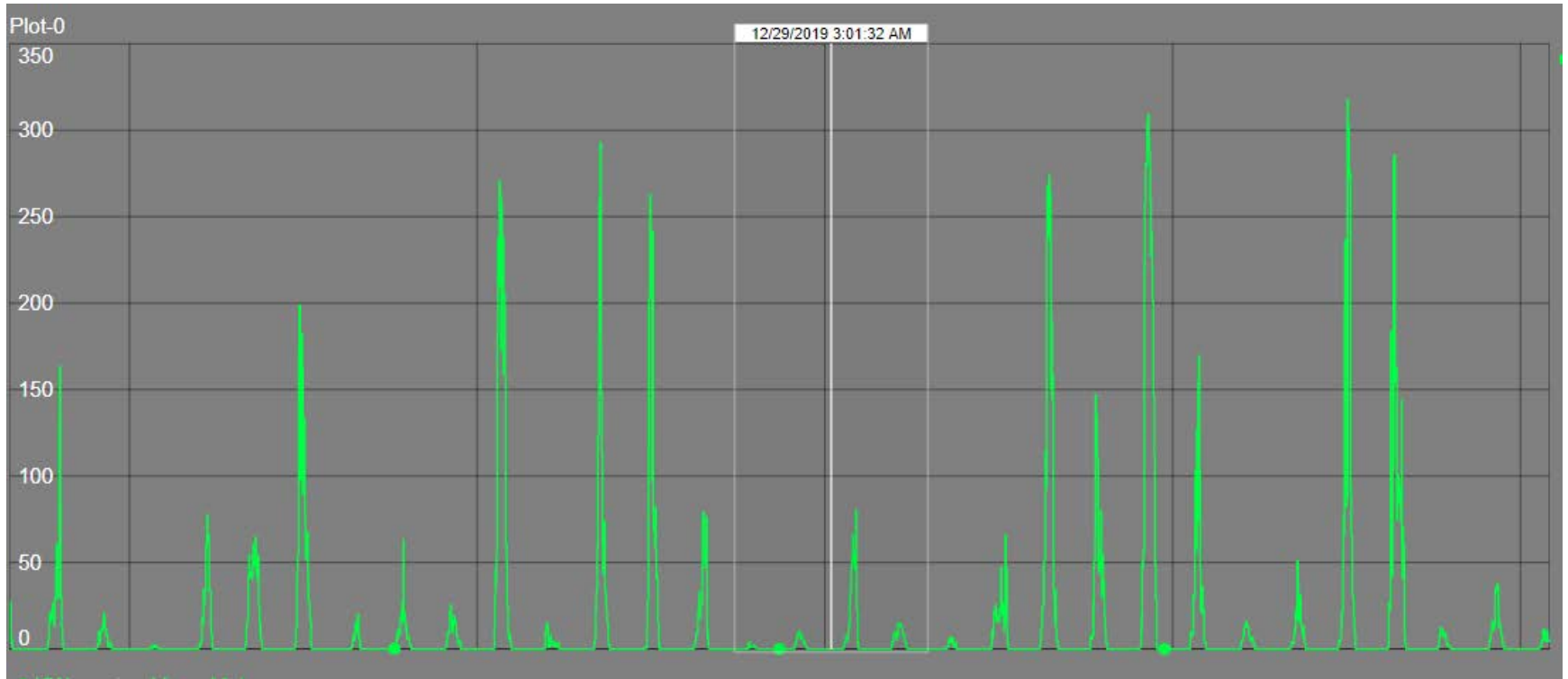

# Can We Fix Curves with Just PV? Community Solar – Cloudy Day, Battery

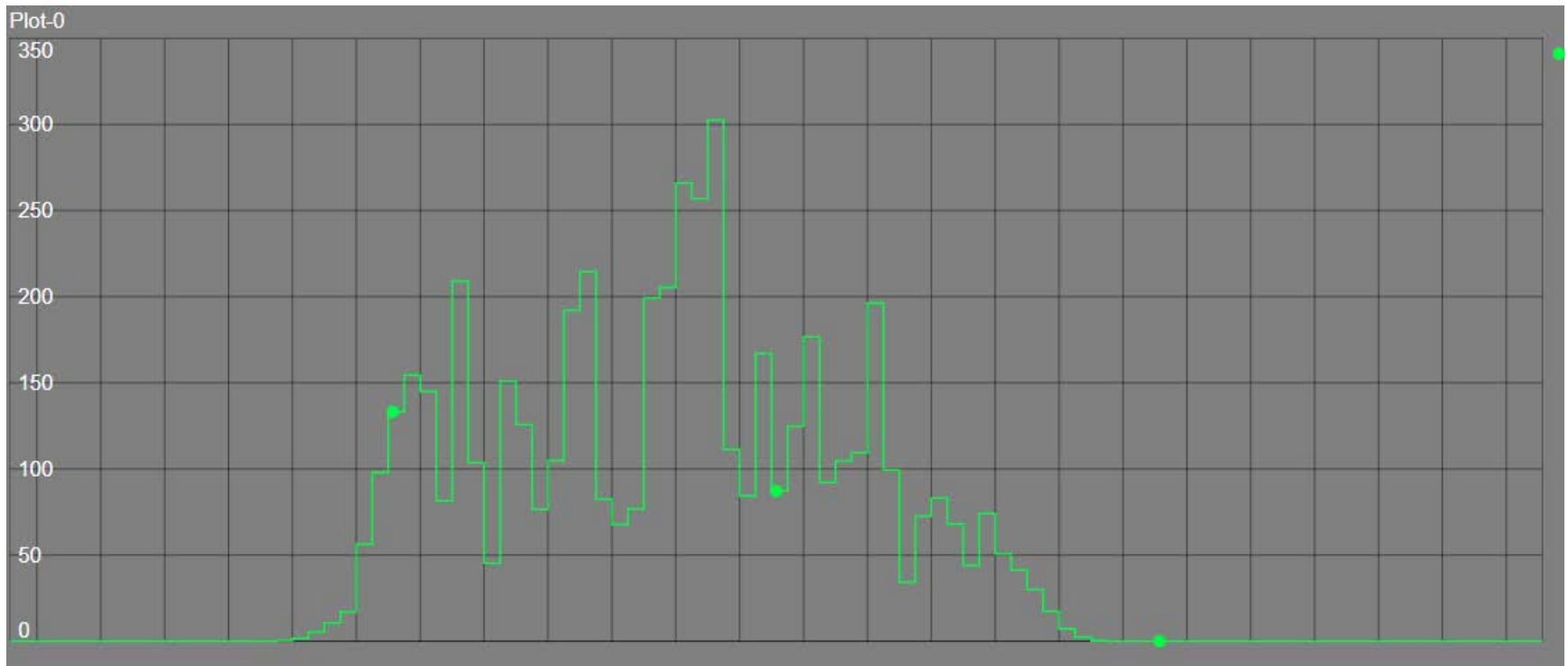

# Capacity Projects

53	Flint Road Station	Scope not complete. New distribution station located north of Spokane along the Airway Heights - Sunset 115 kV Transmission Line.	Q3 2022	Budgeted  Not Scoped	
98	Midway Station	Scope not complete. New distribution station located north of Spokane along the Bell – Addy 115 kV Transmission Line.	Q1 2023	Budgeted  Not Scoped	
80	Huetter Station Expansion	Scope not complete. Rebuild existing distribution station to two 30MVA transformers, 6 feeders, and looped through transmission with circuit breakers.	Q1 2025	Budgeted  Not Scoped	

# Locations

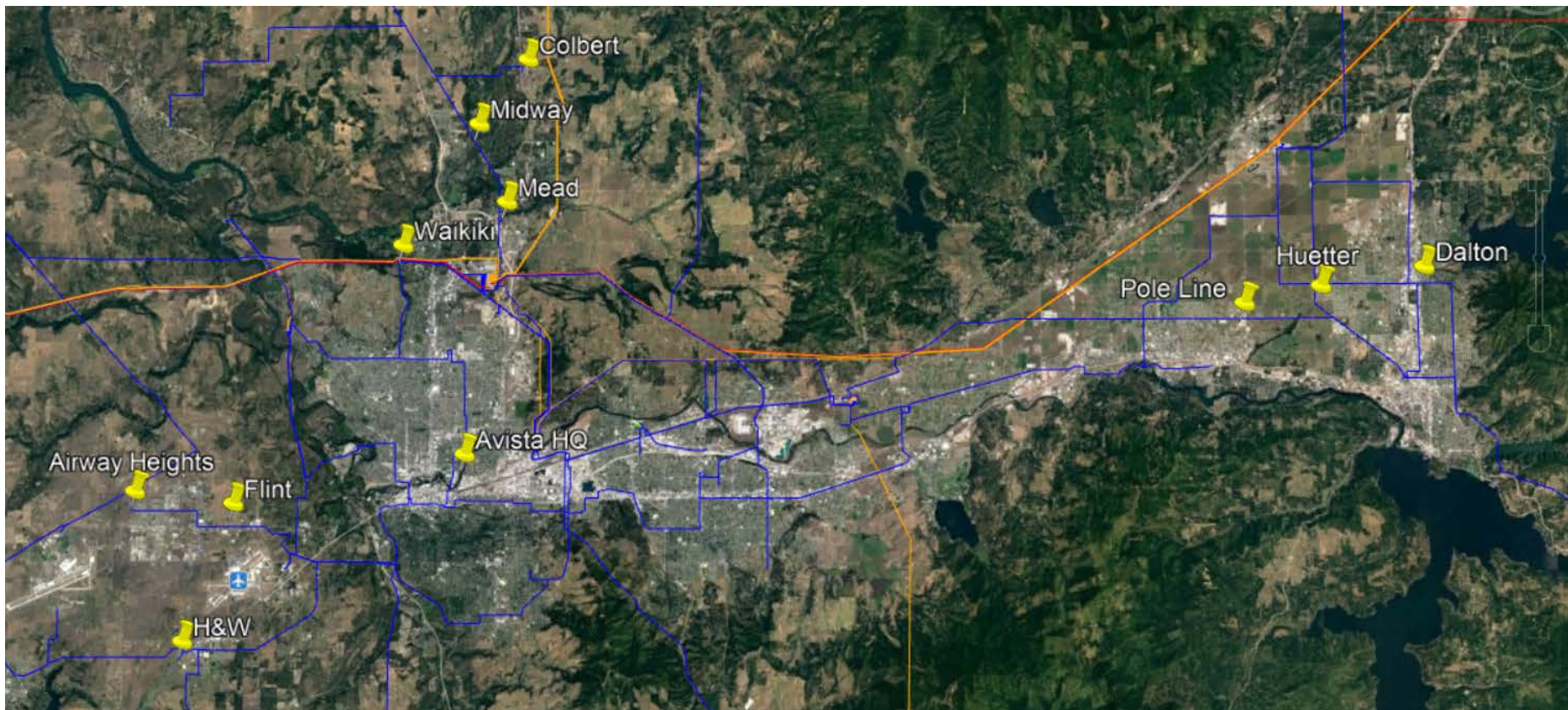

# DRP Implementation Gaps

- Spatial Load Forecasting
- Spatial DER Forecasting
- System Performance Criteria
- DER Acquisition and Implementation Processes
- Engineering/Operational Expertise

# Interesting Distribution Efforts

- AMI data load disaggregation
- Hosting Capacity Maps
  - Example Hosting Capacity map:  
<https://www.arcgis.com/apps/webappviewer/index.html?id=84de299296d649808f5a149e16f2d87c>
- Northwest Utility DER Technical Discussion



# Questions?





# AVISTA DR POTENTIAL STUDY

Preliminary Results Slide Deck – Sep 28, 2020

# AGENDA

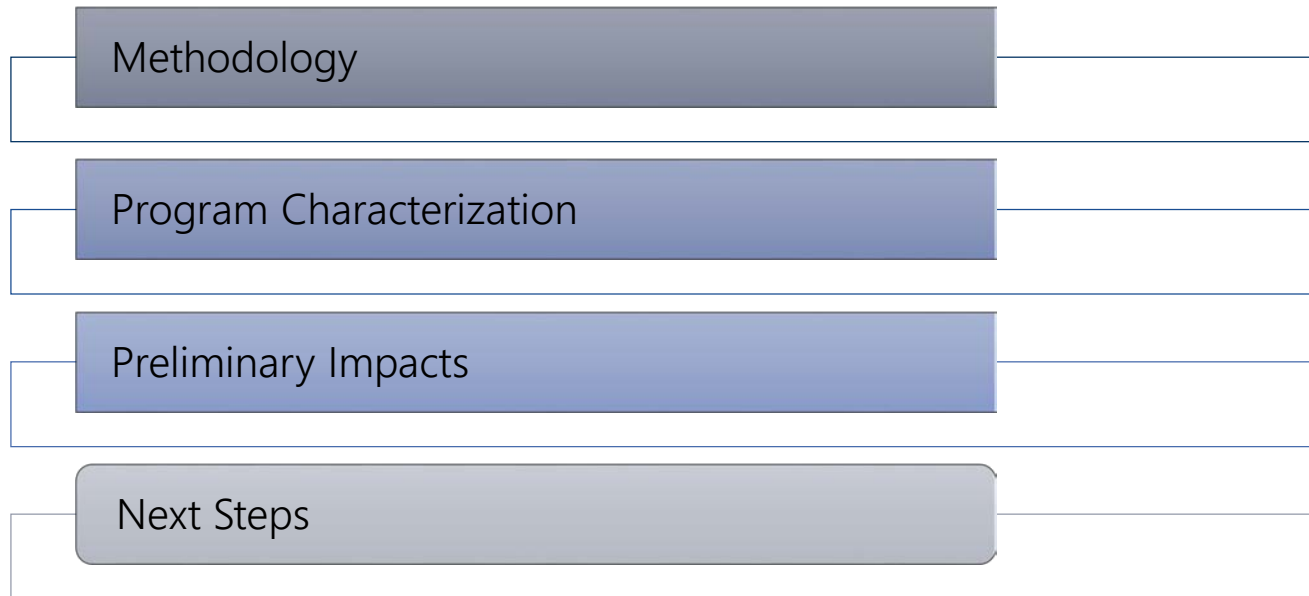



# Methodology

# APPROACH TO THE STUDY

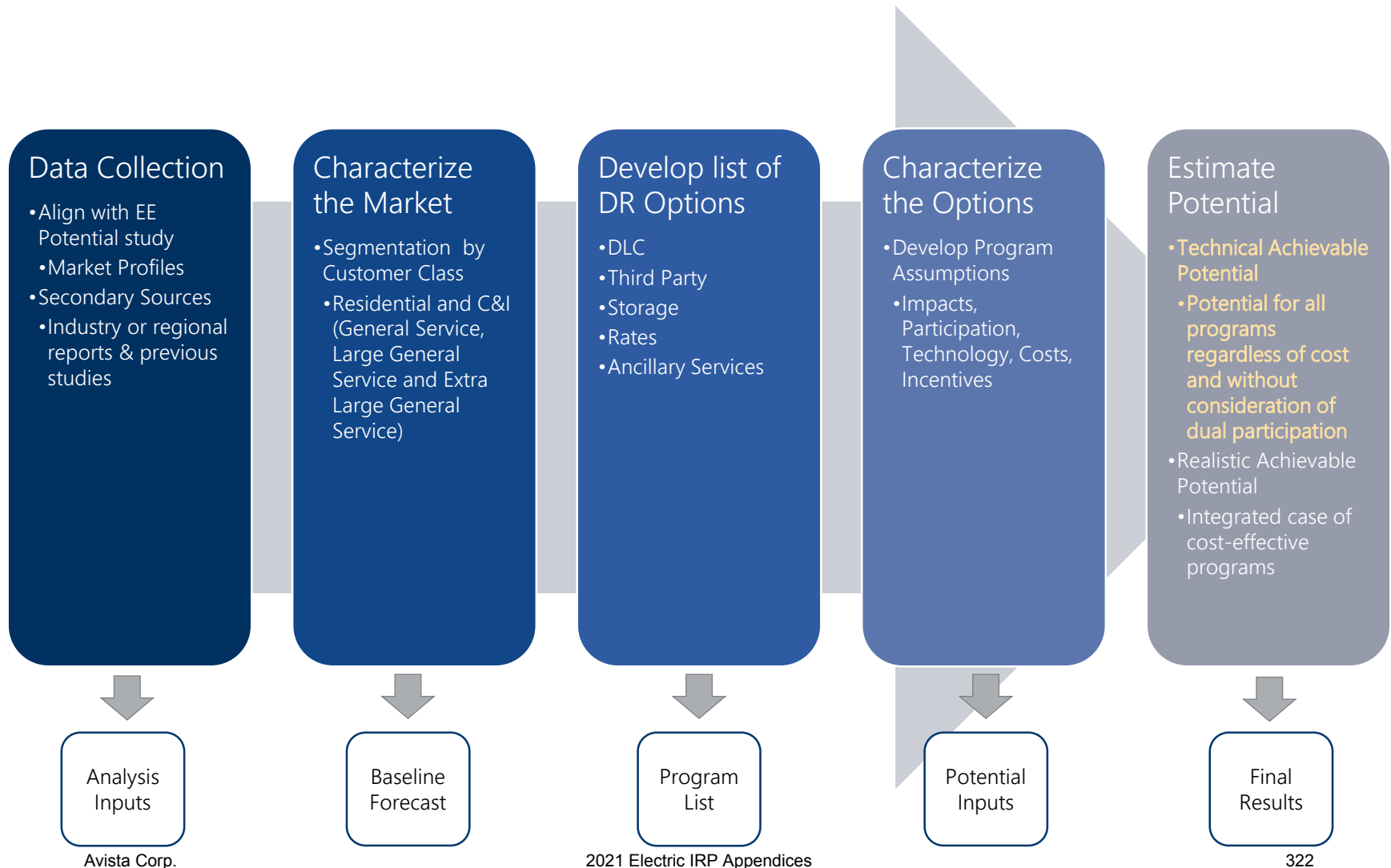

Avista Corp.

2021 Electric IRP Appendices

322

# CALCULATION OF IMPACT (MW)

---

$$\begin{aligned} & \textit{Program Impact}_{\textit{year,program}} \\ &= \textit{Per Customer Peak Impact} * \textit{Eligible Participants} \\ & * \textit{Participation Rate} * \textit{Equipment Saturation Rate} \end{aligned}$$

where:

Year= Forecasted year between 2022 and 2045



# Program Characterization



# DR PROGRAM OPTIONS

Program Type	Program Option	Mechanism
Curtable / Controllable DR	DLC with two-way communicating or Smart T-stats	Internet-enabled control of thermostat set points, can be coupled with any dynamic pricing rate
	DLC Central AC	DLC switch installed on customer’s Central AC
	CTA-2045 Water Heaters (WA)	Modular communications interface for water heaters that will become the new technology standard
	DLC Water Heating (ID)	DLC switch installed on customer’s Water Heater
	DR providing ancillary services (Fast DR)	Automated, fast-responding curtailment strategies with advanced telemetry capabilities suitable for load balancing, frequency regulation, etc. Equipment considered for this option includes: <b>Battery Storage, Thermostats (heating/cooling), Electric Vehicles, Third Party Contracts, and Water Heaters</b>
	Smart Appliance DLC	Internet-enabled control of operational cycles of white goods appliances
	DLC Electric Vehicle Charging	DLC switch installed on customer’s equipment
	Third Party Contracts-	Includes the following three measure options
	Capacity Bidding	Customers volunteer a specified amount of capacity during a predefined “economic event” called by the utility in return for a financial incentive.
	Emergency Curtailment Agreements	Customers enact their customized, mandatory curtailment plan. May use stand-by generation. Penalties apply for non-performance.
	Demand Buyback	Customers enact their customized, voluntary curtailment plan. May use stand-by generation. No penalties for non-performance. Requires AMI technology.
	Battery Energy Storage	Peak shifting of loads using stored electrochemical energy
Behavioral DR	Voluntary DR reductions in response to behavioral messaging. Example programs exist in CA and other states. Requires AMI technology.	
Thermal Energy Storage	Peak shifting of primarily space cooling or heating loads using a thermal storage medium such as water or ice	
Rates	Time-of-use Rates	Higher rate for a particular block of hours that occurs every day. Requires either on/off peak meters or AMI technology.
	Variable Peak Pricing	Much higher rate for a particular block of hours that occurs only on event days. Requires AMI technology.



# AMI ASSUMPTIONS

---

Some of the options require AMI

- DLC Options- No AMI Metering Required
- Dynamic Rates- require AMI for billing
- Ancillary Options- require two way communicating controls

**Washington** currently has 93% AMI saturation

- Assume 100% saturation by 2022

**Idaho** will start AMI rollout in 2022 and will take 18 months to fully deploy

- Assume 33% saturation in 2022 and 100% by 2024

# PARTICIPATION RATES

## DLC PROGRAM OPTIONS

Program Option	Residential	General Service	Large General Service	Extra Large General Service
DLC Central AC	10%	10%		
DLC Smart Thermostats - Cooling	20%	20%		
DLC Smart Thermostats - Heating	5%	3%		
CTA-2045 WH	50%	50%		
DLC Water Heating	15%	5%		
DLC Electric Vehicle Charging	25%			
DLC Smart Appliances	5%	5%		

Sources:

- **DLC Central AC**– NWPCC DLC Switch cooling assumption- 5 yr ramp rate
- **DLC Smart Thermostats (Cooling)** – NWPCC Smart Thermostat cooling assumption- 5 yr ramp rate
- **DLC Smart Thermostats (Heating)** – Agreed upon estimate with Avista. NWPC participation estimate was too high.
- **CTA – 2045 WH** - NWPCC Grid interactive WH assumptions.
- **DLC Water Heating** – Best estimate based on industry experience – in line with other DLC programs
- **DLC Electric Vehicle Charging** – NWPC Electric Resistance Grid-Ready Summer/Winter Participation- 10 yr ramp rate
- **DLC Smart Appliances** - 2015 ISACA IT Risk Reward Barometer - US Consumer Results. October 2015.  
[http://www.isaca.org/SiteCollectionDocuments/2015-risk-reward-survey/2015-isaca-risk-reward-consumer-summary-us\\_res\\_eng\\_1015.pdf](http://www.isaca.org/SiteCollectionDocuments/2015-risk-reward-survey/2015-isaca-risk-reward-consumer-summary-us_res_eng_1015.pdf)

# PARTICIPATION RATES

## RATES AND STORAGE

Program Option	Residential	General Service	Large General Service	Extra Large General Service
Third Party Contracts		15%	20%	20%
Thermal Energy Storage		0.5%	1.5%	1.5%
Battery Energy Storage	0.5%	0.5%	0.5%	0.5%
Behavioral	20%			
Time-of-Use Opt-in	13%	13%	13%	13%
Time-of-Use Opt-out	74%	74%	74%	74%
Variable Peak Pricing Rates	25%	25%	25%	25%

Sources:

- **Third Party Contracts** – Best estimate based on industry experience
- **Thermal Energy Storage** – Best estimate based on industry experience
- **Battery Energy Storage** – Best estimate based on industry experience
- **Behavioral** - PG&E rollout with six waves [http://www.calmac.org/publications/DNVGL\\_PGE\\_HERs\\_2015\\_final\\_to\\_calmac.pdf](http://www.calmac.org/publications/DNVGL_PGE_HERs_2015_final_to_calmac.pdf)
- **Time-of-Use Rates** – Best estimate based on industry experience; Brattle Analysis and Estimate; Winter impacts ½ of summer impacts
- **Variable Peak Pricing Rates** - OG&E 2017 Smart Hours Study
- **Real Time Pricing** - Best estimate based on industry experience

# PEAK IMPACTS DLC PROGRAMS

Season	Program Option	Residential	General Service	Large General Service	Extra Large General Service
Summer only	DLC Central AC	0.5 kW	1.25 kW		
Summer only	DLC Smart Thermostats - Cooling	0.5 kW	1.25 kW		
Winter only	DLC Smart Thermostats - Heating	1.09 kW	1.35 kW		
Annual	CTA-2045 WH	0.5 kW	1.26 kW		
Annual	DLC Water Heating	0.5 kW	1.26 kW		
Annual	DLC Electric Vehicle Charging	0.5 kW			
Annual	DLC Smart Appliances	0.14 kW	0.14 kW		

Sources:

- **DLC Central AC and Smart Thermostats (Cooling)** –NWPC DLC Switch cooling assumption was close to 1.0 kW reduced to adjust for Avista proposed cycling strategy, Thermostats equal to switch
- **DLC Smart Thermostats (Heating)** – NWPC Smart thermostat heating assumption (east)
- **CTA-2045 Water Heating** - NWPC Electric Resistance Grid-Ready Summer/Winter Impact, Gen Service is 2.52x that of res based on DLC Central AC Res to C&I ratio
- **DLC Water Heating**- NWPC Electric Resistance Switch Summer Impact, Gen Service is 2.52x that of res based on DLC Central AC Res to C&I ratio
- **DLC Electric Vehicle Charging** – Based on Avista Research
- **DLC Smart Appliances** - Ghatikar, Rish. Demand Response Automation in Appliance and Equipment. Lawrence Berkley National Laboratory, 2015. Web. [http://docketpublic.energy.ca.gov/PublicDocuments/15-IEPR-05/TN205072\\_20150618T110004\\_Demand\\_Response\\_Automation\\_in\\_Appliances\\_and\\_Equipment.pptx](http://docketpublic.energy.ca.gov/PublicDocuments/15-IEPR-05/TN205072_20150618T110004_Demand_Response_Automation_in_Appliances_and_Equipment.pptx)

Avista Corp.

2021 Electric IRP Appendices

329

# PEAK IMPACTS RATES AND OTHER OPTIONS

Season	Program Option	Residential	General Service	Large General Service	Extra Large General Service
Annual	Third Party Contracts		10%	21%	21%
Annual	Thermal Energy Storage		1.7 kW	8.4 kW	8.4 kW
Annual	Battery Energy Storage	2 kW	2 kW	15 kW	15 kW
Annual	Behavioral	2%			
Annual	Time-of-Use Rate Opt-in	5.7%	0.2%	2.6%	3.1%
Annual	Time-of-Use Rate Opt-out	3.4%	0.2%	2.6%	3.1%
Annual	Variable Peak Pricing Rates	10%	4%	4%	4%

Sources:

- **Third Party Contracts** - Weighted average impacts from report: Impact Estimates from Aggregator Programs in California (Source: 2019 Statewide Load Impact Evaluation of California Aggregator Demand Response Programs)
- **Thermal Energy Storage** - Ice Bear Tech Specifications, <https://www.ice-energy.com/wp-content/uploads/2016/03/ICE-BEAR-30-Product-Sheet.pdf>
- **Battery Energy Storage** – Typical Battery size per segment
- **Behavioral** - Opower documentation for BDR with Consumers and DTE
- **Time-of-Use Rates** –Brattle Analysis and Estimate - PacifiCorp 2019 opt-in and opt-out scenarios. Summer Impacts Shown (Winter impacts ½ summer)
- **Variable Peak Pricing Rates** - OG&E 2018 Smart Hours Study, Summer Impacts Shown (Winter impacts ¾ summer)

# AVERAGE EVENT DURATION FOR DLC OPTIONS

Option	Annual Event Hours	Average Duration per Event	Max Event Duration
Central AC	50	3 hrs	6 hrs
Smart Thermostats - Cooling	36	3 hrs	6 hrs
Smart Thermostats - Heating	36	3 hrs	6 hrs
Water Heating	100	3 hrs	6 hrs
Electric Vehicle Charging	528	6 hrs	8 hrs
Smart Appliances	528	6 hrs	8 hrs
Third Party Contracts	30	4 hrs	8 hrs



# Technical Achievable Potential

DLC Options

# TECHNICAL ACHIEVABLE POTENTIAL WINTER - DLC OPTIONS

Sector	Option	2022	2025	2035	2045
Residential	DLC Central AC	-	-	-	-
	CTA-2045 WH	0.0	1.3	21.1	38.5
	DLC Water Heating	0.5	4.3	4.7	4.6
	DLC Smart Appliances	0.3	2.4	3.0	3.3
	DLC Smart Thermostats - Cooling	-	-	-	-
	DLC Smart Thermostats - Heating	0.8	7.8	9.5	10.5
	DLC Electric Vehicle Charging	-	0.3	5.6	30.2
	Third Party Contracts	4.6	21.9	21.8	21.9
C&I	DLC Central AC	-	-	-	-
	CTA-2045 WH	0.0	0.3	5.2	10.4
	DLC Water Heating	0.1	0.6	0.8	0.9
	DLC Smart Appliances	0.0	0.3	0.3	0.4
	DLC Smart Thermostats - Cooling	-	-	-	-
	DLC Smart Thermostats - Heating	0.0	0.2	0.3	0.3
	DLC Electric Vehicle Charging	-	-	-	-
	Third Party Contracts	4.6	21.9	21.8	21.9

2045 Winter Potential (MW) - DLC Options

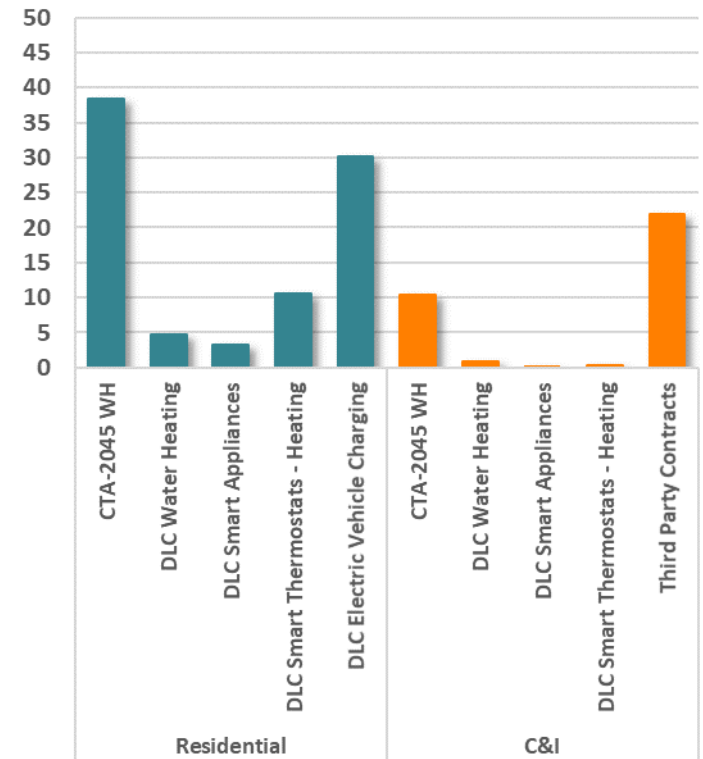



# TECHNICAL ACHIEVABLE POTENTIAL SUMMER - DLC OPTIONS

Sector	Option	2022	2025	2035	2045
Residential	DLC Central AC	0.6	6.8	14.5	23.7
	CTA-2045 WH	0.0	1.3	21.1	38.5
	DLC Water Heating	0.5	4.3	4.7	4.6
	DLC Smart Appliances	0.3	2.4	3.0	3.3
	DLC Smart Thermostats - Cooling	1.2	13.5	29.1	47.4
	DLC Smart Thermostats - Heating	-	-	-	-
	DLC Electric Vehicle Charging	-	0.3	5.6	30.2
C&I	DLC Central AC	0.2	1.9	4.1	6.8
	CTA-2045 WH	0.0	0.3	5.2	10.4
	DLC Water Heating	0.1	0.6	0.8	0.9
	DLC Smart Appliances	0.0	0.3	0.3	0.4
	DLC Smart Thermostats - Cooling	0.3	3.8	8.3	13.5
	DLC Smart Thermostats - Heating	-	-	-	-
	Third Party Contracts	4.5	21.4	21.3	21.4

2045 Summer Potential (MW) - DLC Options

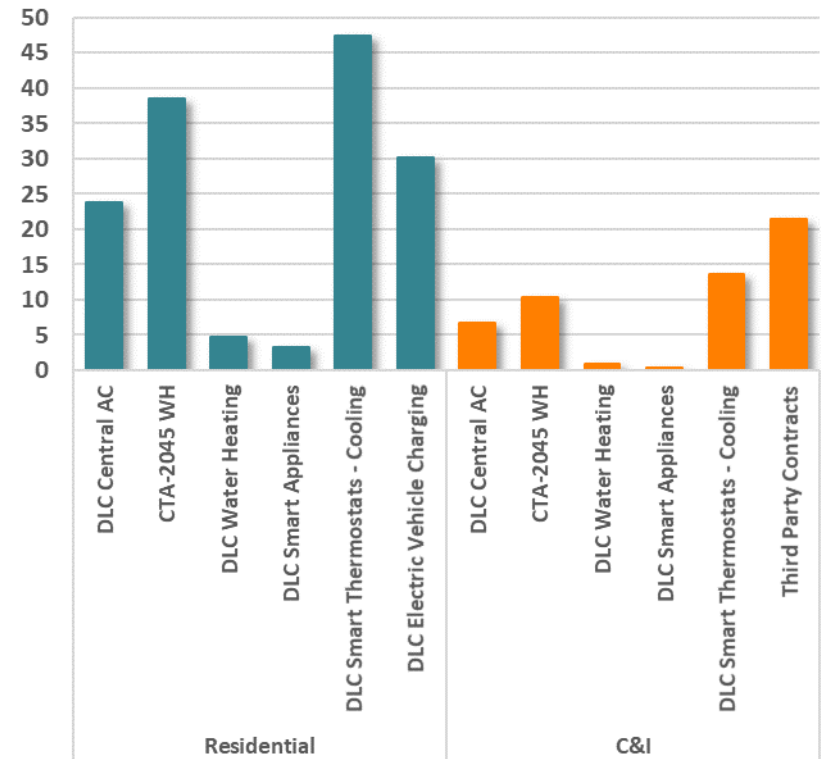



# Technical Achievable Potential

Rates and Other Options

# TECHNICAL ACHIEVABLE POTENTIAL WINTER - RATES AND OTHER OPTIONS

Sector	Option	2022	2025	2035	2045
<b>Residential</b>	Time-of-Use Opt-in	0.4	5.0	5.9	6.2
	Time-of-Use Opt-out	19.6	19.4	20.0	21.1
	Variable Peak Pricing Rates	1.4	16.8	19.7	20.8
	Battery Energy Storage	0.1	0.6	4.3	4.8
	Behavioral	0.6	3.0	3.1	3.3
<b>C&amp;I</b>	Time-of-Use Opt-in	0.1	1.4	1.6	1.5
	Time-of-Use Opt-out	10.4	9.2	8.9	8.8
	Variable Peak Pricing Rates	0.5	5.3	6.0	6.1
	Thermal Energy Storage	-	-	-	-
	Battery Energy Storage	0.0	0.1	0.7	0.8

2045 Winter Potential (MW) - Rates and Other

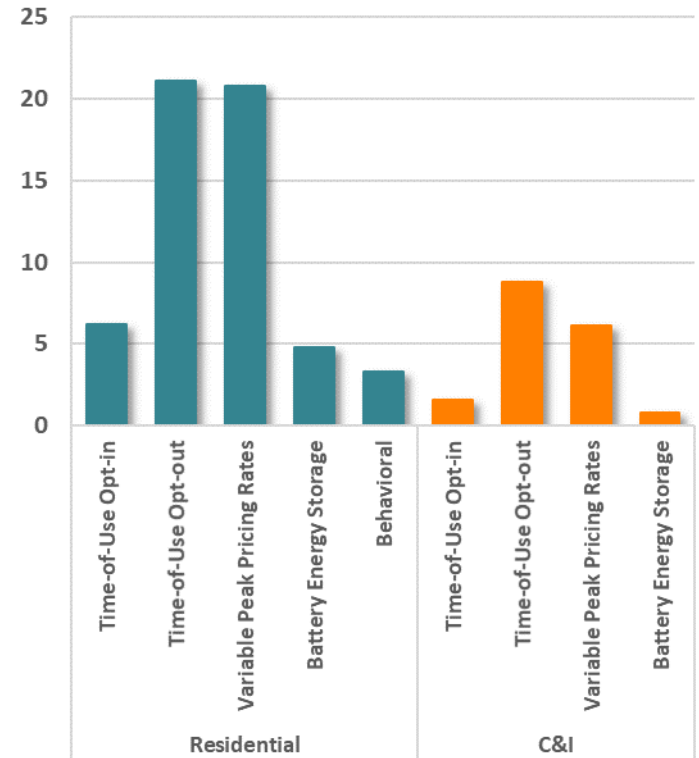

# TECHNICAL ACHIEVABLE POTENTIAL SUMMER - RATES AND OTHER OPTIONS

Sector	Option	2022	2025	2035	2045
<b>Residential</b>	Time-of-Use Opt-in	0.5	5.4	6.3	6.6
	Time-of-Use Opt-out	21.1	20.7	21.4	22.5
	Variable Peak Pricing Rates	1.5	17.9	21.0	22.2
	Battery Energy Storage	0.1	0.6	4.3	4.8
	Behavioral	0.6	3.2	3.4	3.5
<b>C&amp;I</b>	Time-of-Use Opt-in	0.1	1.4	1.5	1.5
	Time-of-Use Opt-out	10.1	8.9	8.6	8.5
	Variable Peak Pricing Rates	0.5	5.2	5.9	6.0
	Thermal Energy Storage	0.1	0.7	0.8	0.8
	Battery Energy Storage	0.0	0.1	0.7	0.8

2045 Summer Potential (MW) - Rates and Other

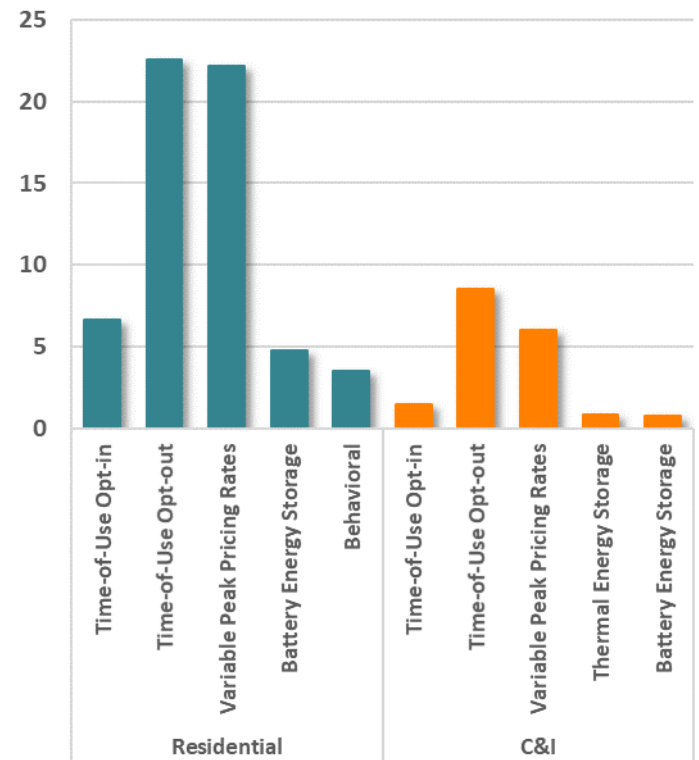



# Ancillary Services

By Option

# ANCILLARY SERVICE ASSUMPTIONS

## Ancillary Option

Battery Energy Storage

Electric Vehicle Charging

DLC Smart Thermostats- Cooling

DLC Smart Thermostats- Heating

DLC Water Heaters

CTA-2045 Water Heaters

Third Party Contracts

## Participation Assumptions

- Full for Battery/EV/WH
- Half for Heating/Cooling
- Third Party based on saturations of EMS systems for PAC C&I

## Impact Assumptions

- Full for Battery/WH
- 75% for Third Party
- Half for Heating/Cooling/EV

# ANCILLARY SERVICES TECHNICAL ACHIEVABLE POTENTIAL

2045 Winter Potential (MW) - Ancillary Options

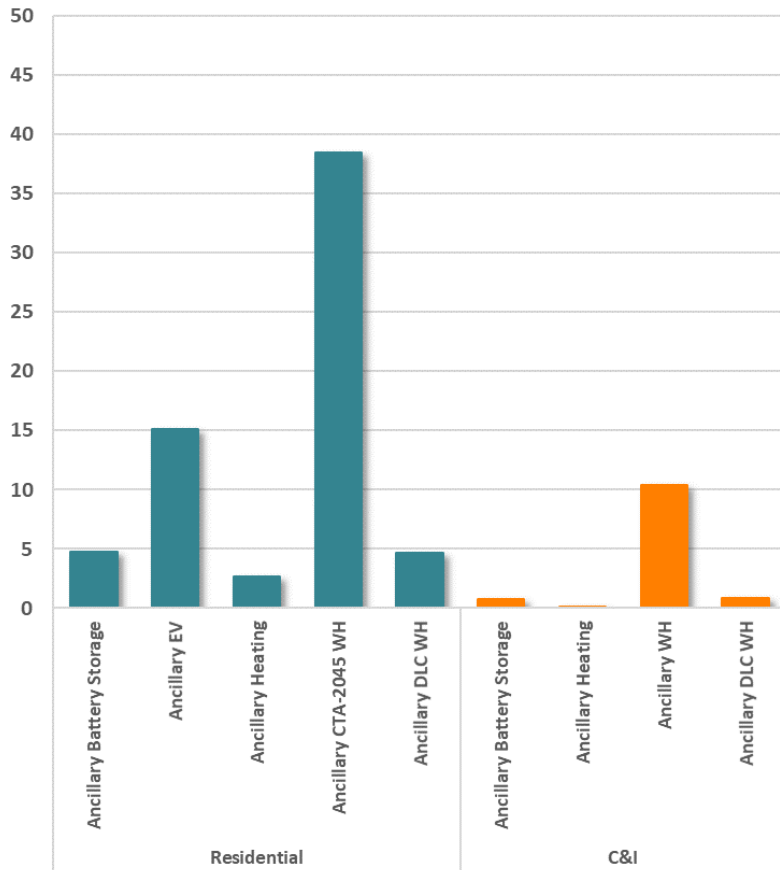

2045 Summer Potential (MW) - Ancillary Options

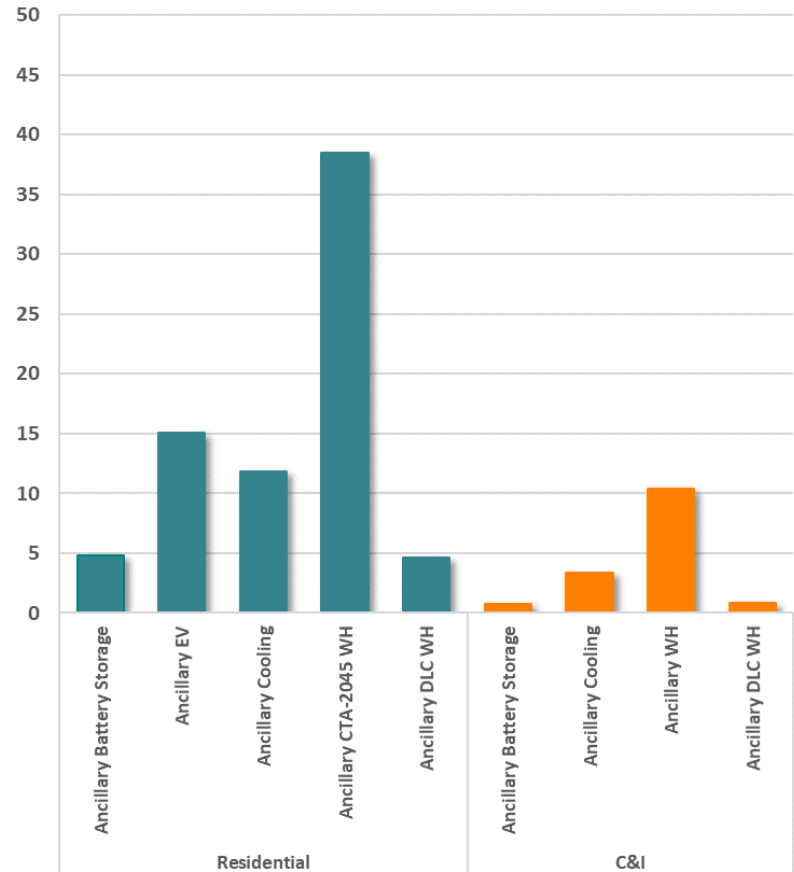



# DR Event Shapes

Load Shifting Assumptions



# SHIFT OR SAVE

In order to incorporate the impacts into the IRP we need to understand how an event affects overall consumption

Depending on the program type, calling an event can have different effects

- Save energy (0% shift)
- Shift energy (100% shift)
- Partial shift

The next slide will show specific examples of each

Graph shows typical event shape for a Residential Variable Peak Pricing program

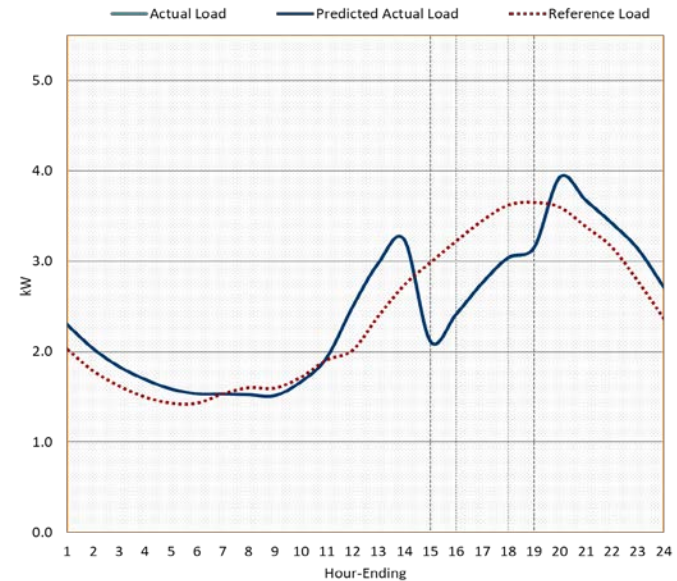

# EVENT LOAD SHAPES

Program	Partial Shift				Full Shift				Full Save				Full Shift spread out before/after event			
	DLC Central AC				CTA-2045 Water Heating				Time-Of-Use Opt-In				Variable Peak Pricing			
State	WA		ID		WA		ID		WA		ID		WA		ID	
Season	Winter	Summer	Winter	Summer	Winter	Summer	Winter	Summer	Winter	Summer	Winter	Summer	Winter	Summer	Winter	Summer
Pre-Event Shift Ratio	0%	0%	0%	0%	0%	0%	0%	0%	0%	0%	0%	0%	35%	35%	35%	35%
Post-Event Shift Ratio	65%	65%	65%	65%	100%	100%	100%	100%	0%	0%	0%	0%	65%	65%	65%	65%
Impact at Peak (kW)	0.50	0.50	0.50	0.50	0.50	0.50	0.50	0.50	0.50	0.50	0.50	0.50	0.50	0.50	0.50	0.50
Peak Impact Percentage	24.9%	23.1%	26.7%	25.5%	24.9%	23.1%	26.7%	25.5%	2.9%	5.7%	2.9%	5.7%	7.5%	10.0%	7.5%	10.0%
Hour Ending																
1	-	-	-	-	-	-	-	-	-	-	-	-	-	-	-	-
14	-	-	-	-	-	-	-	-	-	-	-	-	-	-	-	-
15	-	-	-	-	-	-	-	-	-	-	-	-	(0.08)	(0.11)	(0.07)	(0.10)
16	-	-	-	-	-	-	-	-	-	-	-	-	(0.08)	(0.11)	(0.07)	(0.10)
17	0.43	0.46	0.46	0.46	0.46	0.46	0.46	0.46	0.05	0.11	0.05	0.10	0.14	0.20	0.13	0.18
18	0.46	0.49	0.50	0.49	0.50	0.49	0.50	0.49	0.06	0.12	0.05	0.11	0.15	0.21	0.14	0.19
19	0.46	0.50	0.50	0.50	0.50	0.50	0.50	0.50	0.06	0.12	0.05	0.11	0.15	0.22	0.14	0.20
20	(0.29)	(0.31)	(0.32)	(0.31)	(0.37)	(0.36)	(0.37)	(0.36)	-	-	-	-	(0.10)	(0.14)	(0.09)	(0.12)
21	(0.29)	(0.31)	(0.32)	(0.31)	(0.37)	(0.36)	(0.37)	(0.36)	-	-	-	-	(0.10)	(0.14)	(0.09)	(0.12)
22	(0.29)	(0.31)	(0.32)	(0.31)	(0.37)	(0.36)	(0.37)	(0.36)	-	-	-	-	(0.10)	(0.14)	(0.09)	(0.12)
23	-	-	-	-	(0.37)	(0.36)	(0.37)	(0.36)	-	-	-	-	-	-	-	-
24	-	-	-	-	-	-	-	-	-	-	-	-	-	-	-	-



# Next Steps

# NEXT STEPS

---

Finalize Technical Achievable Potential

Characterize Program Costs

Estimate Achievable Potential

- Integrated case
- Calculate levelized costs

Finalize Results



Kelly Marrin, Managing Director

[kmarrin@appliedenergygroup.com](mailto:kmarrin@appliedenergygroup.com)

Tommy Williams, Lead Analyst

[twilliams@appliedenergygroup.com](mailto:twilliams@appliedenergygroup.com)



# 2020 CONSERVATION POTENTIAL ASSESSMENT – UPDATE

Prepared for the Avista Technical Advisory Committee

# AGENDA

---

## Topics

- AEG Introduction
- AEG's CPA Methodology
- Electric CPA Summary
- DR Analysis Summary
- Natural Gas CPA Summary

# ABOUT AEG

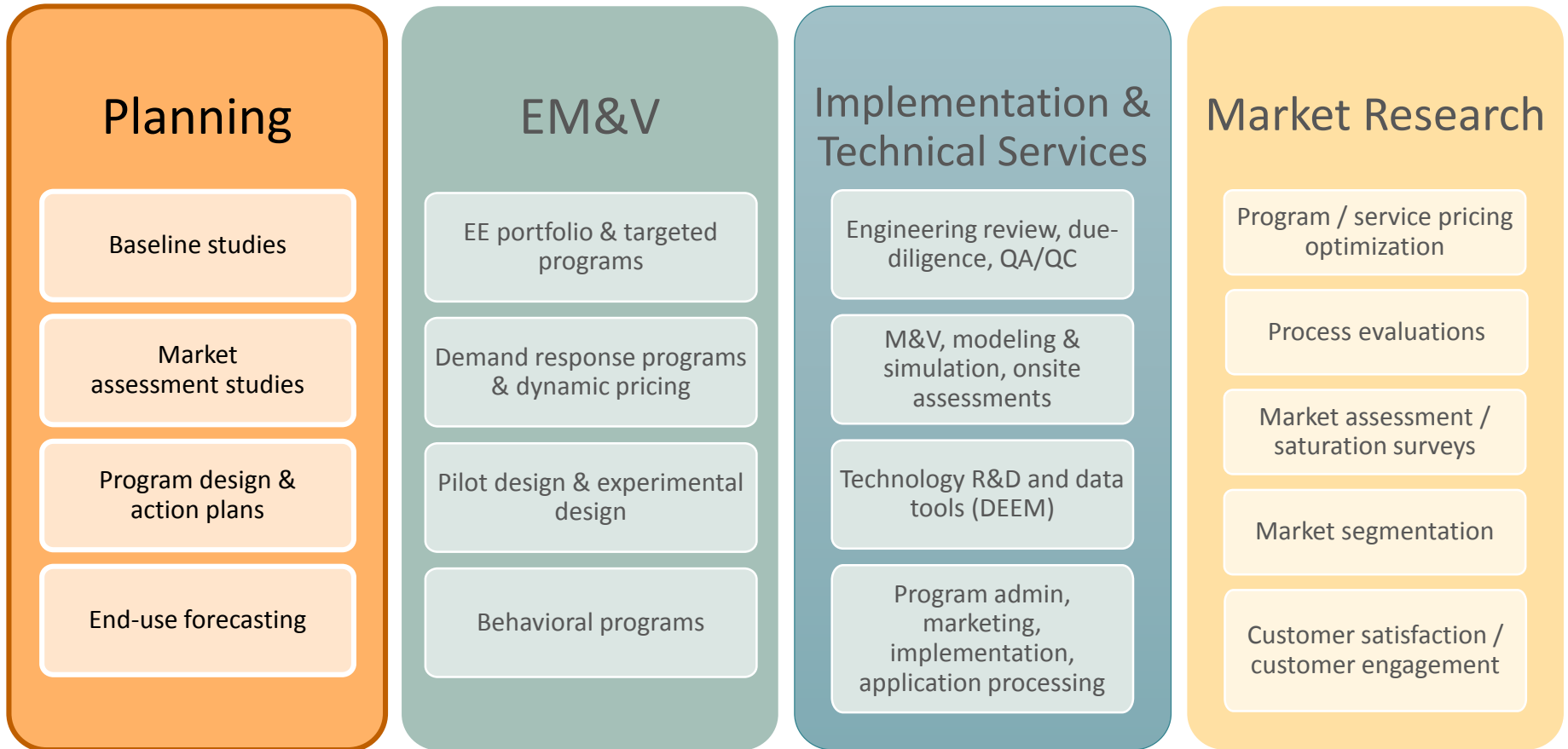

## VISION DSM™ Platform

Full DSM lifecycle tracking & reporting



# AEG EXPERIENCE IN PLANNING

## Including Potential Studies and End-Use Forecasting

AEG has conducted more than 60 planning studies for more than 40 utilities / organizations in the past five years.

AEG has a team of 11 experienced Planning staff plus support from AEG's Technical Services and Program Evaluation groups

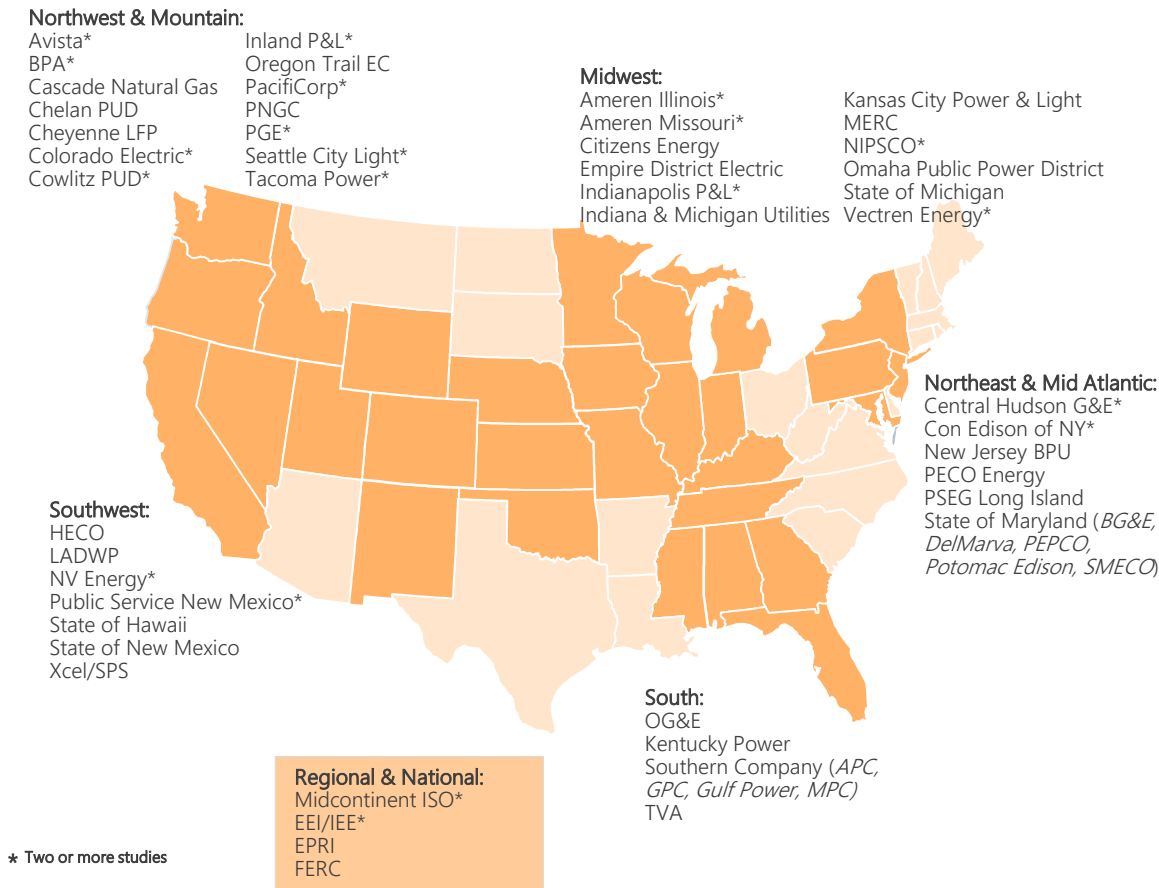



# AEG CPA Methodology

# CPA OBJECTIVES

---

The Avista Conservation Potential Assessment (CPA) supports the Company's regulatory filing and other demand-side management (DSM) planning efforts and initiatives.

The two primary research objectives for the 2020 CPA are:

- **Program Planning:** insights into the market for electric and natural gas energy efficiency (EE) measures and electric demand response (DR) measures in Avista's Washington and Idaho service territories
  - For example, CPAs provide insight into changes to existing program measures as well as new measures to consider
- **IRP:** long-term forecast of future EE and DR potential for use in the IRP
  - Technical Achievable Potential (TAP) for electricity
  - Economic Achievable Potential (EAP) for natural gas

AEG utilizes its comprehensive LoadMAP analytical models that are customized to Avista's service territory.

# OVERVIEW OF AEG'S APPROACH

## Overview – Electric and Gas

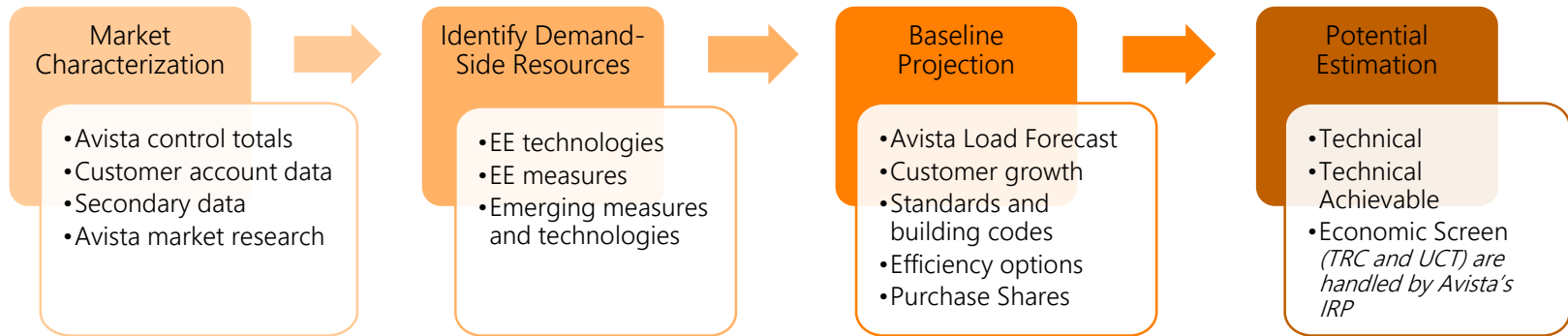

- Market Characterization**
- Avista control totals
  - Customer account data
  - Secondary data
  - Avista market research

- Identify Demand-Side Resources**
- EE technologies
  - EE measures
  - Emerging measures and technologies

- Baseline Projection**
- Avista Load Forecast
  - Customer growth
  - Standards and building codes
  - Efficiency options
  - Purchase Shares

- Potential Estimation**
- Technical
  - Technical Achievable
  - Economic Screen *(TRC and UCT) are handled by Avista's IRP*

Residential Electric Use, 2017

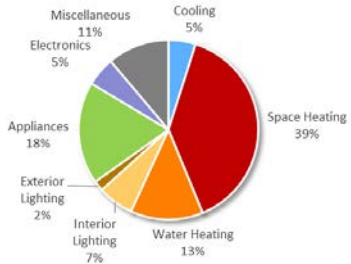

Natural Gas Intensity by End Use & Segment, 2015

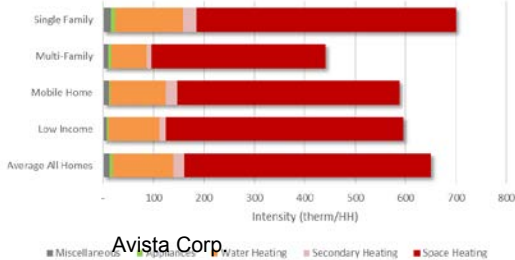

Residential Baseline Forecast

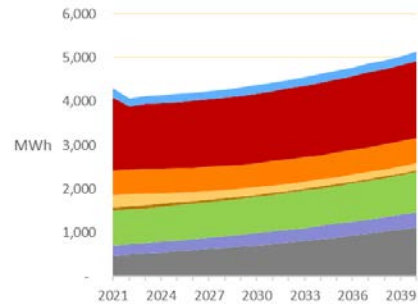

Residential Baseline Projection

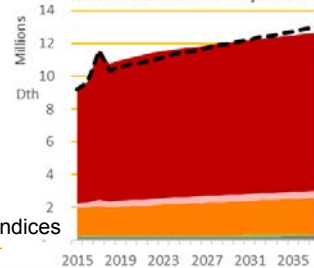

Residential Technical Achievable Potential Savings by End Use

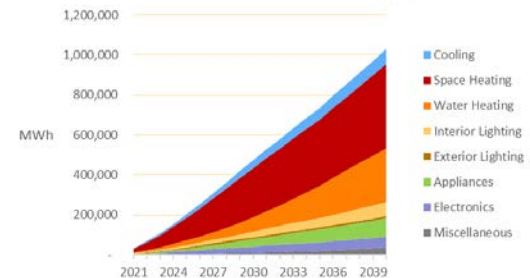

Residential Cumulative Natural Gas Savings

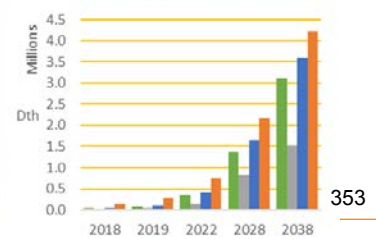

2021 Electric IRP Appendices

# KEY SOURCES OF DATA

## Prioritization of Avista Data

---

Data from Avista was prioritized when available, followed by regional data, and finally well-vetted national data.

### Avista sources include:

- 2013 Residential GenPop Survey
- Forecast data and load research
- Recent-year accomplishments and plans

### Regional sources include:

- NEEA studies (RBSA 2016, CBSA 2019, IFSA)
- RTF and Power Council methodologies, ramp rates, and measure assumptions

### Additional sources include:

- U.S. DOE's Annual Energy Outlook
- U.S. DOE's projections on solid state lighting technology improvements
- Technical Reference Manuals and California DEER
- AEG Research

# BASELINE PROJECTION

## Overview

“How much energy would customers use in the future if Avista stopped running programs now and in the absence of naturally occurring efficiency?”

- The baseline projection answers this question

The baseline projection is an independent end-use forecast of electric or natural gas consumption at the same level of detail as the market profile

### The baseline projection:

#### Includes

- To the extent possible, the same forecast drivers used in the official load forecast, particularly customer growth, natural gas prices, normal weather, income growth, etc.
- Trends in appliance saturations, including distinctions for new construction.
- Efficiency options available for each technology , with share of purchases reflecting codes and standards (current and finalized future standards)
- Expected impact of appliance standards that are “on the books”
- Expected impact of building codes, as reflected in market profiles for new construction
- Market baselines when present in regional planning assumptions

#### Excludes

- Expected impact of naturally occurring efficiency (except market baselines)
  - **Exception:** RTF workbooks have a market baseline for lighting, which AEG’s models also use.
- Impacts of current and future demand-side management programs



# Electric CPA

# AVISTA 2020 ELECTRIC CPA

---

## CPA Methodology Overview

- Levels of Potential
- Economic Evaluation and IRP Integration
- Retained enhancements from 2018 Action Plan

## Summary of EE Results

- Summary of Potential
  - High level results
  - Top measures
  - Potential by cost bundles
- Comparison to previous CPA

## Summary of DR Results



# TWO LEVELS OF SAVINGS ESTIMATES

## Power Council Methodology

- Focus of the study is to explore a wide range of options for reducing annual energy use
- This study develops two sets of estimates:
  - Technical potential (TP): everyone chooses the most efficient option possible when equipment fails
    - This may include emerging or very expensive ultra-high efficiency technologies
  - Technical Achievable Potential (TAP) is a subset of TP that accounts for customer preference and likelihood to adopt through **both** utility-and non-utility driven mechanisms
    - To better emulate likely programs, Technical Achievable Potential calculates savings from efficient options more likely to be selected by the IRP
- In addition to these estimates, the study produces cost data for the TRC and UCT tests that can be used by Avista’s IRP process to select energy efficiency measures in competition with other resources

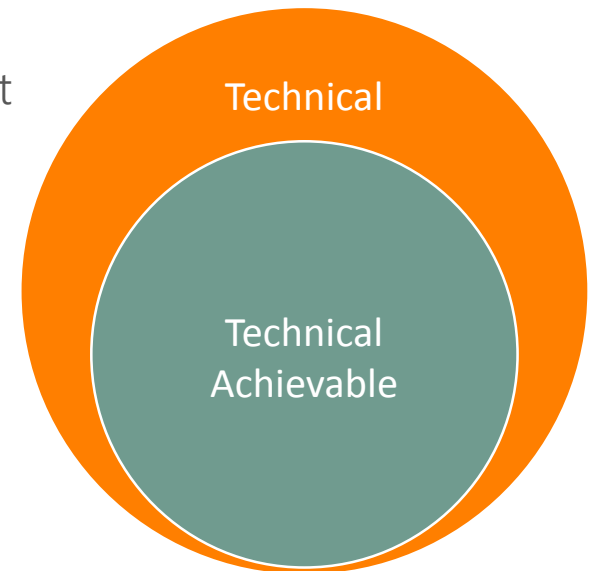

# ECONOMIC METRICS

## Two Cost-Effectiveness Tests

AEG provided a levelized net cost of energy (\$/kWh) for each measure within the achievable potential within Avista’s Washington and Idaho territories from two perspectives.

- **Utility Cost Test (UCT):** Assesses cost-effectiveness from a utility or program administrator’s perspective.
- **Total Resource Cost Test (TRC):** Assesses cost-effectiveness from the utility’s and participant’s perspectives. Includes non-energy impacts if they can be quantified and monetized.

Component	UCT	TRC
Avoided Energy	Benefit	Benefit
Non-Energy Benefits*		Benefit
Incremental Cost		Cost
Incentive	Cost	
Administrative Cost	Cost	Cost
Non-Energy Costs* (e.g. O&M)		Cost

\*Council methodology includes monetized impacts on other fuels within these categories

Both values are provided to Avista for all measure level potential, so that the IRP can use the appropriate evaluation for each state: TRC for WA and UCT for ID.

# ENHANCEMENTS RETAINED FROM 2018 CPA

---

AEG has preserved the enhancements to the CPA process that were included in the previous CPA:

- Any measures screened out in advance of technical potential are documented in the measure list along with the reason. As before, very few measures were excluded in this step
  - Measures that were excluded were generally either emerging measures with insufficient data to characterize properly, or highly custom measures that are instead modeled within broader retrocommissioning or strategic energy management programs.
- Full Technical Achievable potential is provided to the IRP along with TRC and UCT costs for each measure
- The Measure Assumptions appendix is again available, containing UES data and other key assumptions and their sources
- Demand Response potential includes analysis of both Summer and Winter possible programs

# POTENTIAL ESTIMATES

## Achievability

All potential “ramps up” over time – all ramp rates are based on those found within the NWPCC’s 2021 Power Plan

- **Max Achievability**

- NWPCC 2021 Plan allows some measures max achievability to reach up to 100% of technical potential
- 7th Power Plan and prior CPA had a max achievability of 85%
- AEG has aligned assumptions with the 2021 Plan and measures such as lighting reach greater than 85%
- **Please note** Power Council’s ramp rates include potential realized from outside of utility DSM programs, including regional initiatives and market transformation

Measures examples over 85% Achievability:

- All Lighting
- Washers/Dryers
- Dishwashers
- Refrigerators/Freezers
- Circulation Pumps
- Thermostats
- C&I Fans

# ENERGY EFFICIENCY POTENTIAL

## Potential Summary –WA & ID All Sectors

Projections indicate that energy savings of ~1.0% of baseline consumption per year are Technically Achievable.

- 190 GWh (22 aMW) in biennium period (2022-2023)
- 1,317 GWh (150 aMW) by 2031
- This level of savings offsets future load growth

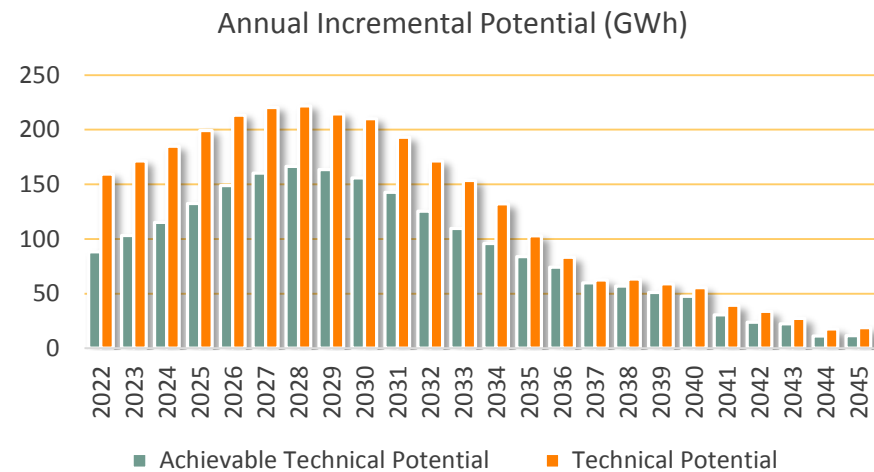
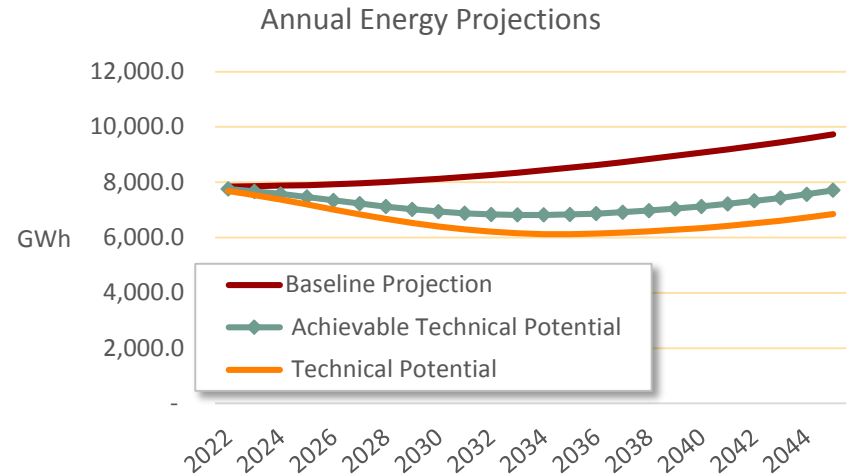

# EE POTENTIAL, CONTINUED

## Potential Summary – WA & ID, All Sectors

Cumulative ATP Savings (GWh) by Sector

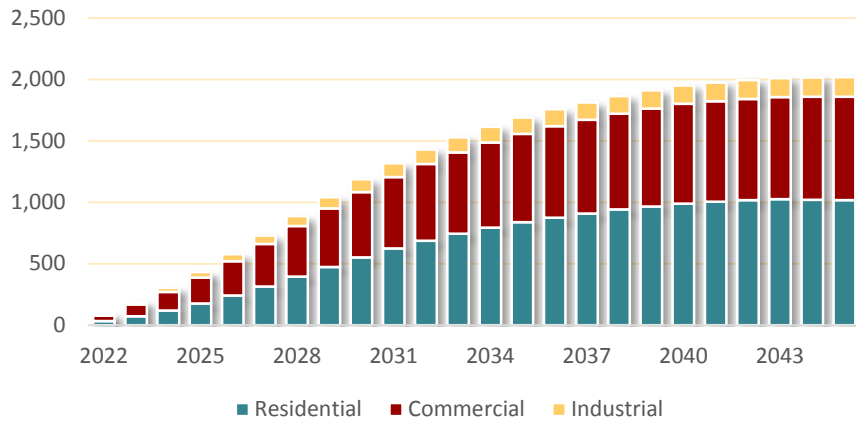

Cumulative Electric Savings, selected years

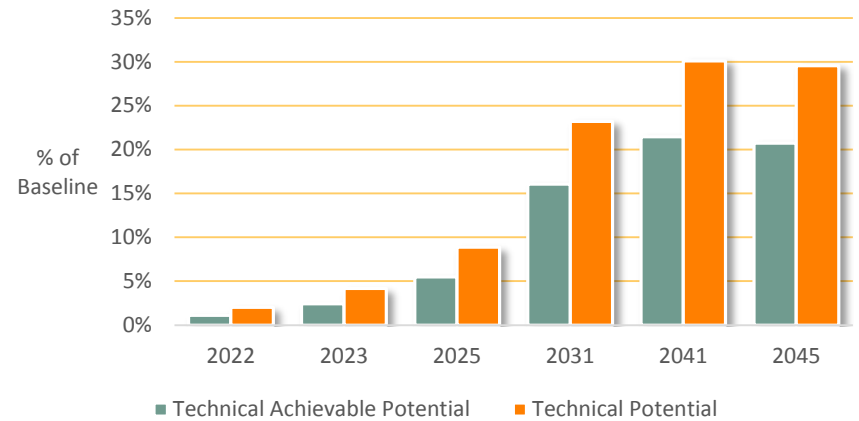

Summary of Energy Savings (GWh), Selected Years	2022	2023	2025	2031	2041	2045
<b>Reference Baseline</b>	7,842	7,863	7,898	8,192	9,193	9,727
<b>Cumulative Savings (GWh)</b>						
Technical Achievable Potential	88	190	432	1,317	1,974	2,019
Technical Potential	159	327	703	1,901	2,770	2,878
<b>Energy Savings (% of Baseline)</b>						
Technical Achievable Potential	1.1%	2.4%	5.5%	16.1%	21.5%	20.8%
Technical Potential	2.0%	4.2%	8.9%	23.2%	30.1%	29.6%
<b>Incremental Savings (GWh)</b>						
Technical Achievable Potential	88	103	133	143	31	11
Technical Potential	159	171	199	193	39	19

# EE POTENTIAL - CONTINUED

## ATP Peak Savings Summary – WA & ID, All Sectors

ATP Summer Peak Savings (MW)

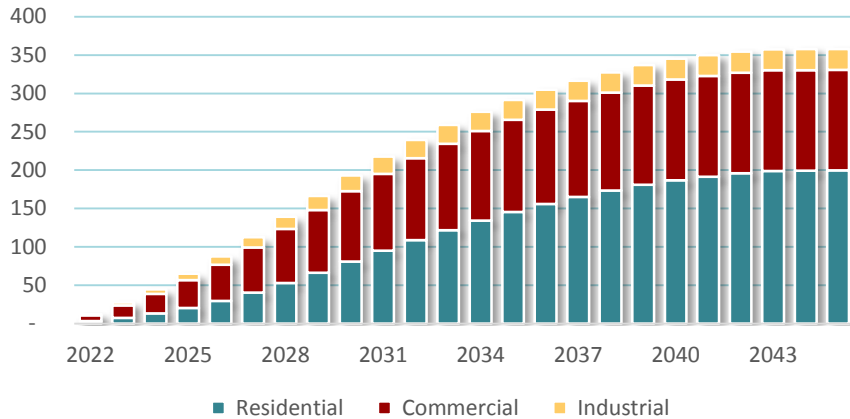

ATP Winter Peak Savings (MW)

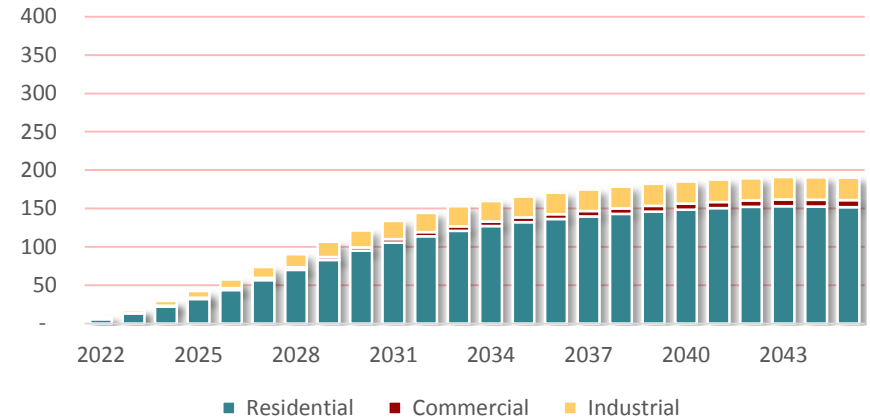

EE Peak Savings (MW), Selected Years	2022	2023	2025	2031	2041	2045
<b>Reference Baseline</b>						
Summer Peak MW	1,626	1,642	1,677	1,834	2,272	2,406
Winter Peak MW	1,518	1,522	1,529	1,574	1,716	1,791
<b>Cumulative Savings (MW)</b>						
Summer Peak	12.6	27.5	64.9	217.6	349.9	357.8
Winter Peak	8.2	18.2	42.6	134.1	187.5	190.1
<b>Cumulative Savings (% of Baseline)</b>						
Summer Peak	0.8%	1.7%	3.9%	11.9%	15.4%	14.9%
Winter Peak	0.5%	1.2%	2.8%	8.5%	10.9%	10.6%
<b>Incremental Savings (MW)</b>						
Summer Peak	12.8	15.2	20.4	25.9	4.9	0.9
Winter Peak	8.2	10.1	13.5	14.5	2.7	0.2

# EE POTENTIAL BY SECTOR

## Achievable Technical Potential – WA & ID

	2022	2023	2024	2031	2041
<b>Baseline projection (GWh)</b>					
Residential	3,774	3,785	3,796	3,953	4,489
Commercial	3,223	3,234	3,248	3,427	3,924
Industrial	845	843	839	812	780
<b>Total Consumption (GWh)</b>	<b>7,842</b>	<b>7,863</b>	<b>7,883</b>	<b>8,192</b>	<b>9,193</b>
<b>ATP Cumulative Savings (GWh)</b>					
Residential	32	72	120	623	1,004
Commercial	46	97	152	583	819
Industrial	10	21	33	110	151
<b>Total Savings (GWh)</b>	<b>88</b>	<b>190</b>	<b>304</b>	<b>1,317</b>	<b>1,974</b>
<b>ATP Cumulative Savings (aMW)</b>					
Residential	4	8	14	71	115
Commercial	5	11	17	67	94
Industrial	1	2	4	13	17
<b>Total Savings (aMW)</b>	<b>10</b>	<b>22</b>	<b>35</b>	<b>150</b>	<b>225</b>
<b>ATP Cumulative Savings as a % of Baseline</b>					
Residential	0.8%	1.9%	3.1%	15.8%	22.4%
Commercial	1.4%	3.0%	4.7%	17.0%	20.9%
Industrial	1.2%	2.5%	3.9%	13.6%	19.3%
<b>Total Savings (% of Baseline)</b>	<b>1.1%</b>	<b>2.4%</b>	<b>3.9%</b>	<b>16.1%</b>	<b>21.5%</b>

ATP Savings by Sector (% of Baseline)

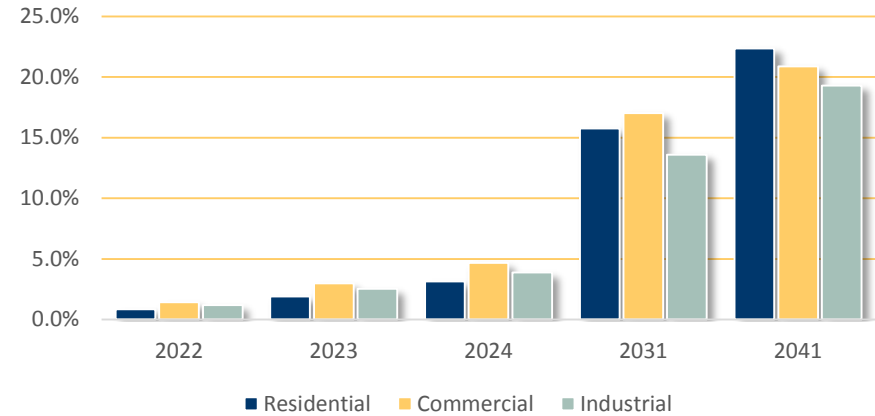

Cumulative ATP Savings (GWh) by Sector

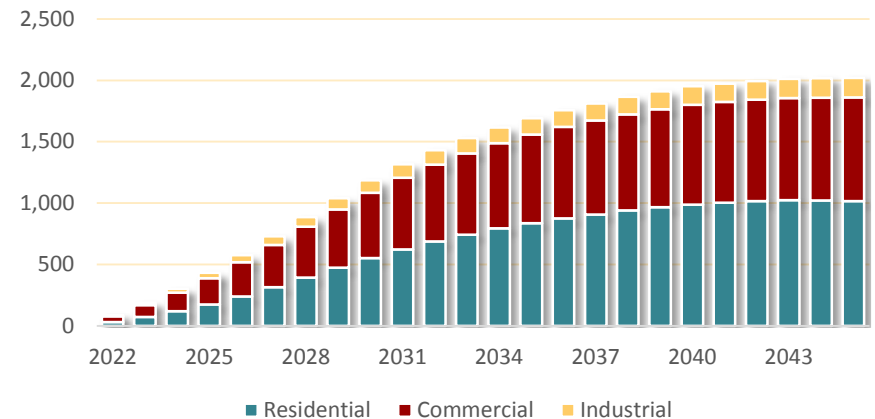



# EE POTENTIAL - TOP MEASURES

## Cumulative Potential Summary – WA & ID All Sectors

Technical Achievable Potential, Ranked by Savings in 2031 (MWh)

Rank	Measure / Technology	2023 Achievable Technical Potential (MWh)	% of Total	2031 Achievable Technical Potential (MWh)	% of Total	TRC Levelized \$/kWh	UCT Levelized \$/kWh
1	Commercial - Linear Lighting	9,139	4.8%	62,302	4.7%	\$0.01	\$0.00
2	Commercial - Retrocommissioning	9,318	4.9%	59,994	4.6%	\$0.04	\$0.04
3	Residential - Water Heater <= 55 Gal	2,647	1.4%	55,156	4.2%	\$0.06	\$0.05
4	Commercial - Strategic Energy Management	7,047	3.7%	44,581	3.4%	\$0.09	\$0.08
5	Residential - Ductless Mini Split Heat Pump (Zonal)	6,599	3.5%	42,085	3.2%	\$0.60	\$0.44
6	Residential - ENERGY STAR - Connected Thermostat	5,890	3.1%	40,216	3.1%	\$0.18	\$0.17
7	Residential - Windows - High Efficiency/ENERGY STAR	5,808	3.1%	35,780	2.7%	\$1.14	\$0.79
8	Residential - Ductless Mini Split Heat Pump with Optimized Controls (Ducted Forced Air)	1,485	0.8%	33,420	2.5%	\$0.37	\$0.26
9	Residential - Home Energy Management System (HEMS)	4,975	2.6%	30,271	2.3%	\$0.27	\$0.23
10	Residential - Windows - Cellular Shades	988	0.5%	28,248	2.1%	\$0.18	\$0.15
11	Commercial - HVAC - Dedicated Outdoor Air System (DOAS)	3,054	1.6%	21,141	1.6%	\$0.68	\$0.49
12	Residential - Insulation - Basement Sidewall Installation	2,933	1.5%	20,698	1.6%	\$0.04	\$0.03
13	Commercial - Space Heating - Heat Recovery Ventilator	5,128	2.7%	20,274	1.5%	\$0.14	\$0.10
14	Commercial - High-Bay Lighting	4,123	2.2%	19,394	1.5%	\$0.00	\$0.00
15	Residential - Windows - Low-e Storm Addition	2,832	1.5%	18,790	1.4%	\$0.82	\$0.33
16	Residential - Furnace - Conversion to Air-Source Heat Pump	639	0.3%	15,407	1.2%	\$0.08	\$0.06
17	Industrial - High-Bay Lighting	6,056	3.2%	14,687	1.1%	\$0.00	\$0.00
18	Commercial - General Service Lighting	3,181	1.7%	13,705	1.0%	\$0.05	\$0.03
19	Commercial - Interior Lighting - Embedded Fixture Controls	2,470	1.3%	13,523	1.0%	\$0.08	\$0.06
20	Residential - Connected Line-Voltage Thermostat	1,817	1.0%	13,433	1.0%	\$0.12	\$0.10
<b>Total of Top 20 Measures</b>		<b>86,126</b>	<b>45.2%</b>	<b>603,105</b>	<b>45.8%</b>		
<b>Total Cumulative Savings</b>		<b>190,351</b>	<b>100.0%</b>	<b>1,316,823</b>	<b>100.0%</b>		

Avista Corp.

2021 Electric IRP Appendices

366

# SUPPLY CURVES

## WA & ID Technical Achievable Potential by 2031

TRC Conservation Supply Curve, 2031

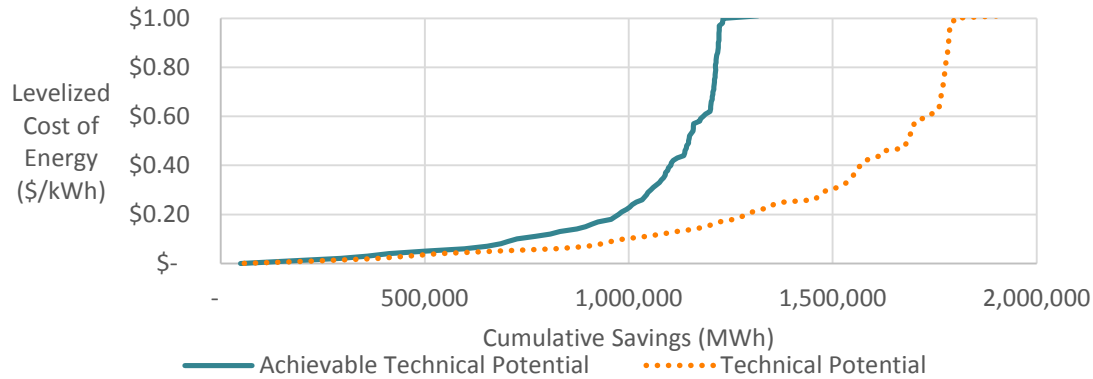

UCT Conservation Supply Curve, 2031

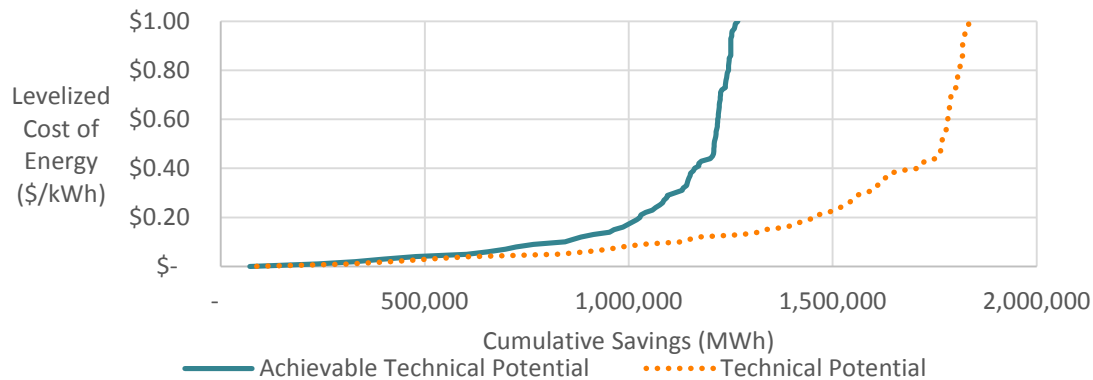

# EE POTENTIAL

## Top Measure Notes

---

- Some expensive or emerging measures have significant **technical achievable** potential, but may not be selected by the IRP due to costs
- Heat Pump measures, including DHPs and HPWHs, have significant annual energy benefits, however since heat pumps revert to electric resistance heating during extreme cold, they do not have a corresponding winter peak benefit
- In addition to being expensive, some emerging tech measures are included in Technical Achievable which may not prove feasible for programs at this time, but can be kept in mind for future programs, e.g.:
  - Advanced New Construction – Zero Net Energy
  - Connected Home Control Systems

# EE POTENTIAL - CONTINUED

## Peak Impacts – Technical Achievable Potential

	Top Measures - Winter Peak (MW) Reduction by 2031	2031 MW	% of Total
1	Residential - ENERGY STAR - Connected Thermostat	12	8.9%
2	Residential - Windows - High Efficiency/ENERGY STAR	10	7.8%
3	Residential - Windows - Cellular Shades	8	5.8%
4	Residential - Insulation - Basement Sidewall Installation	7	5.4%
5	Residential - Windows - Low-e Storm Addition	7	5.0%
6	Residential - Home Energy Management System (HEMS)	5	4.0%
7	Residential - Connected Line-Voltage Thermostat	5	3.4%
8	Commercial - Linear Lighting	4	3.2%
9	Residential - Building Shell - Air Sealing (Infiltration Control)	4	3.0%
10	Residential - Insulation - Floor Upgrade	4	2.9%
11	Residential - Ducting - Repair and Sealing	4	2.7%
12	Residential - Insulation - Floor Installation	3	2.5%
13	Residential - Water Heater <= 55 Gal	3	2.5%
14	Residential - Insulation - Ducting	3	2.4%
15	Residential - Ducting - Repair and Sealing - Aerosol	3	2.2%
16	Residential - Building Shell - Liquid-Applied Weather-Resistive Barrier	3	2.2%
17	Industrial - Fan System - Equipment Upgrade	3	1.9%
18	Industrial - Retrocommissioning	3	1.9%
19	Residential - Building Shell - Whole-Home Aerosol Sealing	2	1.8%
20	Industrial - Strategic Energy Management	2	1.6%
	<b>Total of Top 20 Measures</b>	<b>95</b>	<b>70.9%</b>
	<b>Total Cumulative Savings</b>	<b>134</b>	<b>100.0%</b>

	Top Measures - Summer Peak (MW) Reduction by 2031	2031 MW	% of Total
1	Commercial - Retrocommissioning	12	5.6%
2	Residential - ENERGY STAR - Connected Thermostat	11	5.0%
3	Residential - Windows - High Efficiency/ENERGY STAR	11	5.0%
4	Residential - Windows - Cellular Shades	10	4.8%
5	Residential - Ductless Mini Split Heat Pump (Zonal)	8	3.7%
6	Commercial - Strategic Energy Management	8	3.6%
7	Residential - Whole-House Fan - Installation	7	3.2%
8	Residential - Room AC - Removal of Second Unit	7	3.1%
9	Residential - Home Energy Management System (HEMS)	6	2.7%
10	Commercial - HVAC - Dedicated Outdoor Air System (DOAS)	6	2.6%
11	Residential - Insulation - Ceiling Installation	6	2.6%
12	Commercial - RTU - Evaporative Precooler	5	2.4%
13	Commercial - Linear Lighting	5	2.2%
14	Residential - Ductless Mini Split Heat Pump with Optimized Controls (Ducted Forced Air)	4	1.9%
15	Residential - Insulation - Wall Sheathing	4	1.9%
16	Commercial - Chiller - Variable Flow Chilled Water Pump	4	1.8%
17	Residential - Central AC	4	1.8%
18	Residential - Building Shell - Liquid-Applied Weather-Resistive Barrier	4	1.7%
19	Commercial - RTU - Advanced Controls	3	1.5%
20	Residential - Behavioral Programs (Incremental)	3	1.5%
	<b>Total of Top 20 Measures</b>	<b>128</b>	<b>58.7%</b>
	<b>Total Cumulative Savings</b>	<b>218</b>	<b>100.0%</b>

# COST OF SAVINGS

## WA – TAP by Bundled \$/kWh

### Washington

TRC \$/kWh	2022	2023	2031
< \$0.00	2,899	6,276	30,063
\$0.00 - \$0.05	21,071	45,441	321,449
\$0.06 - \$0.10	7,784	17,210	136,569
\$0.11 - \$0.20	8,689	19,108	163,687
\$0.21 - \$0.30	3,809	7,928	50,997
\$0.31 - \$0.40	1,680	3,665	29,050
\$0.41 - \$0.50	985	2,128	16,590
\$0.51 - \$0.75	2,750	5,952	39,772
\$0.76 - \$1.00	1,233	2,685	17,996
\$1.01 - \$1.50	2,754	5,954	34,569
\$1.51 - \$2.00	419	880	5,849
> \$2.00	1,671	3,574	21,755

UCT \$/kWh	2022	2023	2031
< \$0.00	3,050	6,417	45,484
\$0.00 - \$0.05	25,187	54,710	377,861
\$0.06 - \$0.10	7,546	16,772	144,587
\$0.11 - \$0.20	6,766	14,588	115,890
\$0.21 - \$0.30	3,248	6,814	42,005
\$0.31 - \$0.40	1,603	3,418	27,599
\$0.41 - \$0.50	2,349	5,229	36,677
\$0.51 - \$0.75	1,639	3,542	22,466
\$0.76 - \$1.00	1,959	4,190	23,004
\$1.01 - \$1.50	712	1,522	10,768
\$1.51 - \$2.00	623	1,296	6,795
> \$2.00	1,061	2,305	15,209

WA TAP by Cost Bundle - 2031

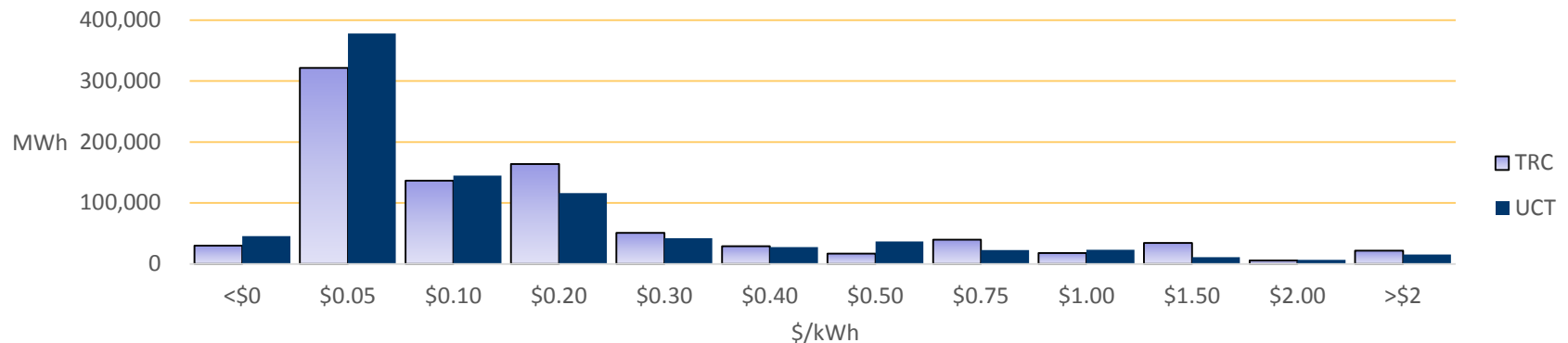

# COST OF SAVINGS

## ID – TAP by Bundled \$/kWh

### Idaho

TRC \$/kWh	2022	2023	2031
< \$0.00	1,906	4,142	18,262
\$0.00 - \$0.05	11,189	23,472	135,613
\$0.06 - \$0.10	5,225	11,304	84,553
\$0.11 - \$0.20	5,335	11,461	84,826
\$0.21 - \$0.30	1,776	3,826	28,334
\$0.31 - \$0.40	1,037	2,306	19,831
\$0.41 - \$0.50	1,959	4,258	27,243
\$0.51 - \$0.75	1,638	3,594	23,138
\$0.76 - \$1.00	304	638	3,560
\$1.01 - \$1.50	806	1,705	9,065
\$1.51 - \$2.00	334	693	4,180
> \$2.00	1,047	2,148	9,873

UCT \$/kWh	2022	2023	2031
< \$0.00	1,631	3,449	25,696
\$0.00 - \$0.05	12,929	27,284	153,798
\$0.06 - \$0.10	6,082	13,171	96,251
\$0.11 - \$0.20	4,224	9,124	67,796
\$0.21 - \$0.30	2,767	6,061	43,471
\$0.31 - \$0.40	1,455	3,140	21,259
\$0.41 - \$0.50	837	1,826	11,325
\$0.51 - \$0.75	406	884	5,279
\$0.76 - \$1.00	633	1,322	6,969
\$1.01 - \$1.50	540	1,124	6,089
\$1.51 - \$2.00	409	825	3,796
> \$2.00	642	1,337	6,748

ID TAP by Cost Bundle - 2031

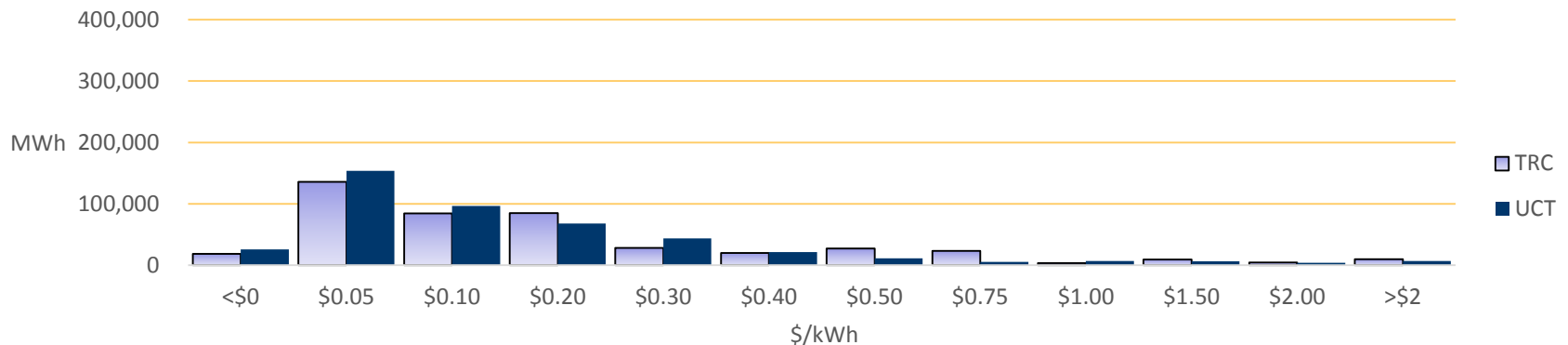

# EE POTENTIAL, CONTINUED

## Potential Summary – Washington, All Sectors

Cumulative TAP Savings (GWh) by Sector

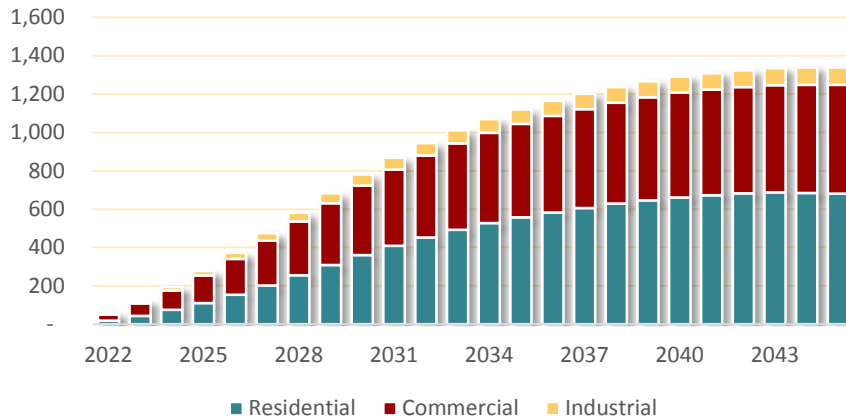

Cumulative Electric Savings

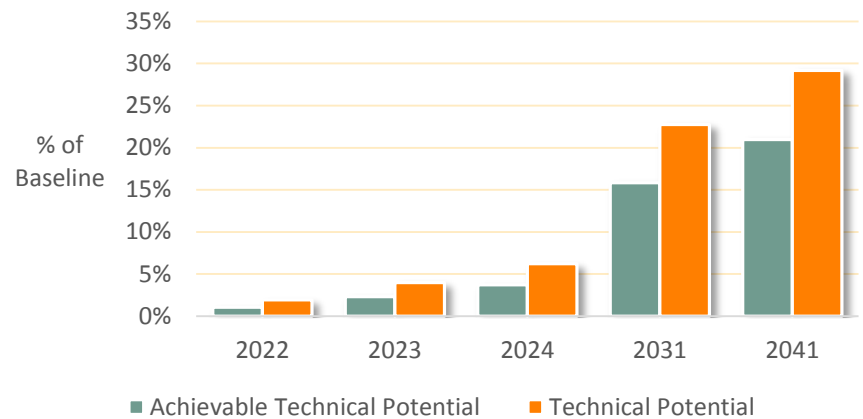

	2022	2023	2024	2031	2041
<b>Baseline projection (GWh)</b>	5,196	5,212	5,229	5,479	6,243
<b>Cumulative Savings (GWh)</b>					
Achievable Technical Potential	56	121	194	868	1,309
Technical Potential	101	209	325	1,247	1,822
<b>Cumulative Savings (aMW)</b>					
Achievable Technical Potential	6	14	22	99	149
Technical Potential	12	24	37	142	208
<b>Cumulative Savings as a % of Baseline</b>					
Achievable Technical Potential	1.1%	2.3%	3.7%	15.8%	21.0%
Technical Potential	2.0%	4.0%	6.2%	22.8%	29.2%

# EE POTENTIAL, CONTINUED

## Potential Summary – Idaho, All Sectors

Cumulative TAP Savings (GWh) by Sector

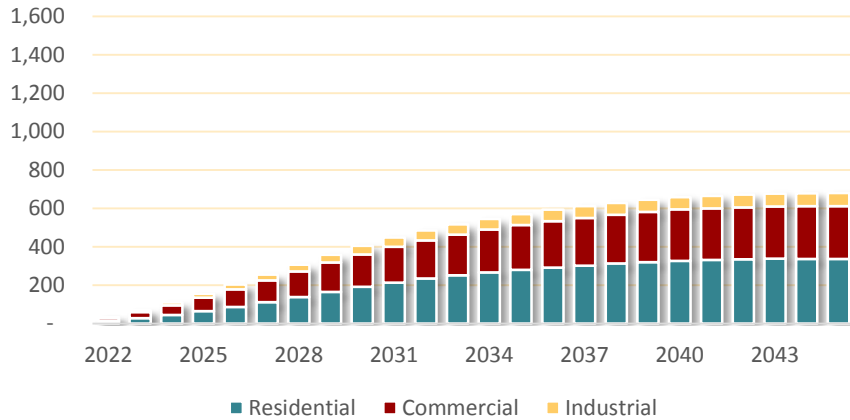

Cumulative Electric Savings

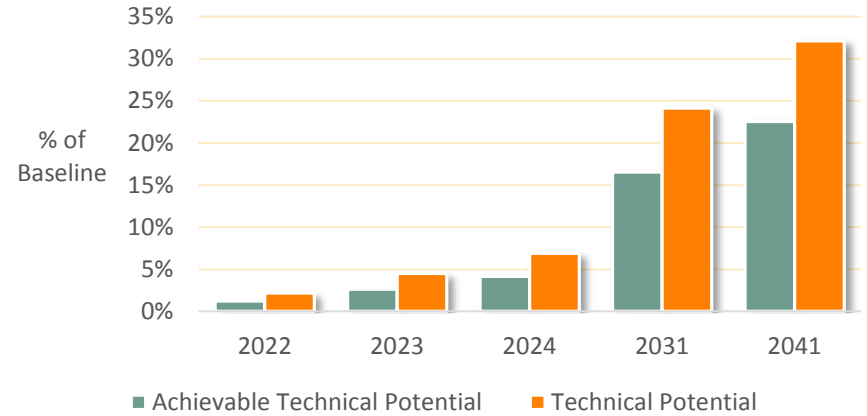

	2022	2023	2024	2031	2041
<b>Baseline projection (GWh)</b>	2,646	2,650	2,653	2,713	2,951
<b>Cumulative Savings (GWh)</b>					
Achievable Technical Potential	33	70	110	448	665
Technical Potential	58	119	183	654	948
<b>Cumulative Savings (aMW)</b>					
Achievable Technical Potential	4	8	13	51	76
Technical Potential	7	14	21	75	108
<b>Cumulative Savings as a % of Baseline</b>					
Achievable Technical Potential	1.2%	2.6%	4.1%	16.5%	22.5%
Technical Potential	2.2%	4.5%	6.9%	24.1%	32.1%





# Comparison with 2018 Electric CPA

# NOTES ON COMPARISON

## Comparison with Prior Potential Study

---

We are often asked to compare results between current and prior potential study estimates – it is important to define comparison parameters.

Aligning calendar years, rather than study years results in a more thorough comparison

- This is mainly due to things like equipment standards, which come on by calendar year, not relative to the start year of the study

Since we are not estimating potential in 2021, potential for that year must be removed from the comparison

- **First-Year Incremental Potential - 2022**
  - Prior Study: 2nd year of potential
  - Current Study: first year

The previous study's 20-year look ended in 2040, therefore we must remove 2041-2045 from the comparison

- **Cumulative Potential Comparisons – 2022 through year 2040**
  - This should have a minimal impact on potential since retrofits are mainly captured prior to this point

As a result, we can draw up to a 19 year comparison (2022-2040)

# ACHIEVABLE POTENTIAL COMPARISON

## Comparison with Prior Potential Study (2022-2037 TAP)

Washington All-Sector TAP Comparison

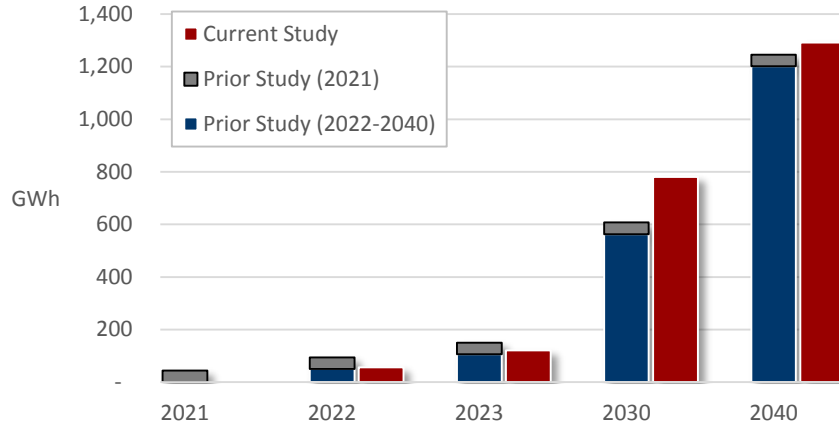

Idaho All-Sector TAP Comparison

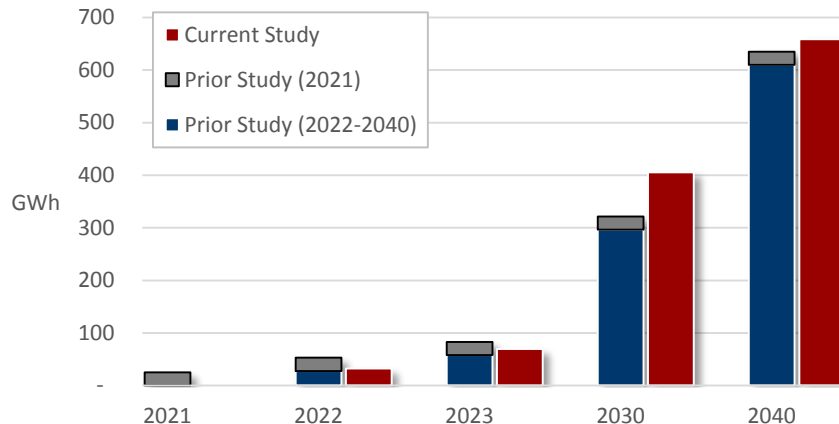

Sector (All States)	End Use	Prior CPA 2040 MWh	Current Study 2040 MWh	Diff.
<b>Residential</b>	Cooling	74,528	112,573	38,045
	Heating	444,182	442,897	-1,285
	Water Heating	267,144	217,843	-49,301
	Interior Lighting	63,331	24,122	-39,209
	Exterior Lighting	10,059	4,122	-5,937
	Appliances	91,966	82,297	-9,668
	Electronics	49,899	58,651	8,752
	Miscellaneous	35,248	45,661	10,413
	<b>Commercial</b>	Cooling	99,708	145,262
Heating		33,372	100,989	67,617
Ventilation		73,363	116,241	42,878
Water Heating		22,078	26,182	4,104
Interior Lighting		261,940	210,469	-51,471
Exterior Lighting		103,244	61,188	-42,057
Refrigeration		42,103	119,602	77,499
Food Preparation		0	8,517	8,517
Office Equipment		3,805	14,945	11,139
<b>Industrial</b>	Miscellaneous	2,018	10,216	8,198
	Cooling	6,160	4,779	-1,381
	Heating	11,042	566	-10,476
	Ventilation	7,942	11,679	3,736
	Interior Lighting	52,125	49,781	-2,344
	Exterior Lighting	12,428	5,213	-7,215
	Motors	33,106	69,081	35,975
	Process	10,059	7,012	-3,047
	Miscellaneous	671	775	104
<b>Grand Total</b>		<b>1,811,520</b>	<b>1,950,662</b>	<b>139,142</b>
				<b>376</b>

# SECTOR-LEVEL ACHIEVABLE POTENTIAL

## Washington - Comparison with Prior Study – Technical Achievable

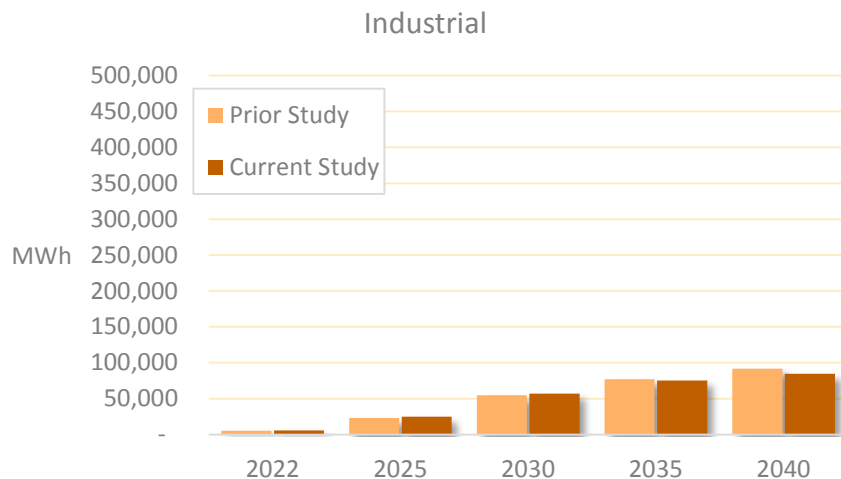
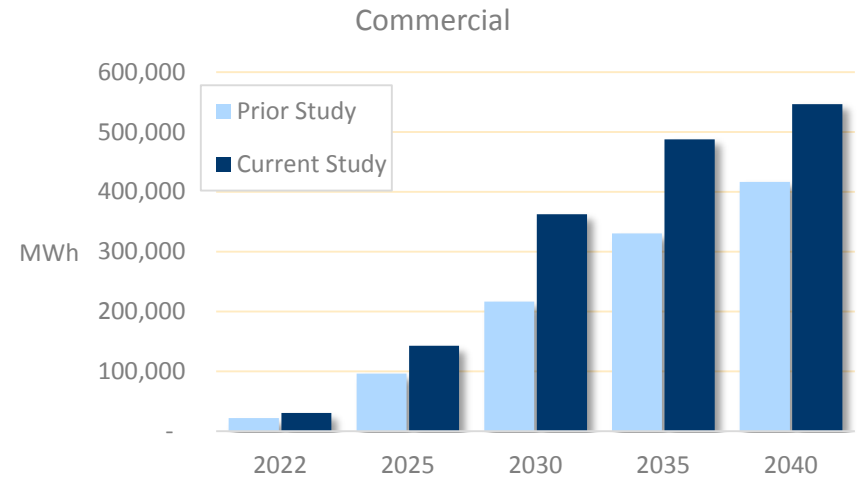
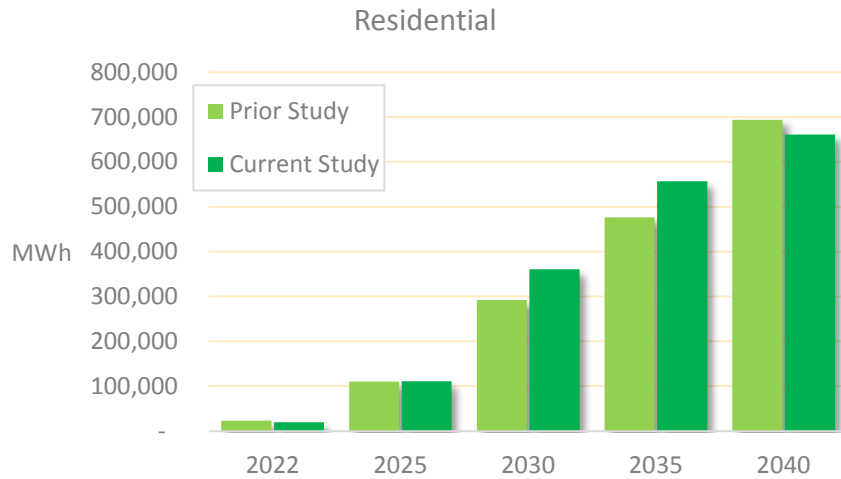

- 2020 savings already removed from prior study values

# SECTOR-LEVEL ACHIEVABLE POTENTIAL

## Idaho - Comparison with Prior Study – Technical Achievable

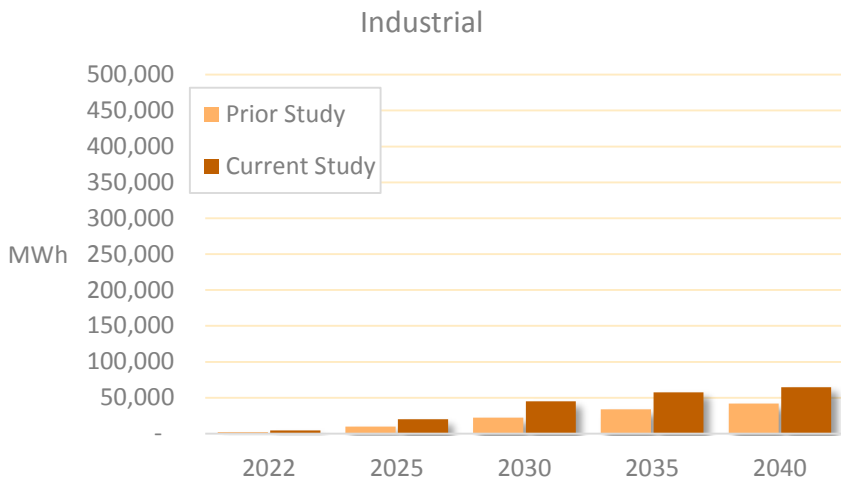
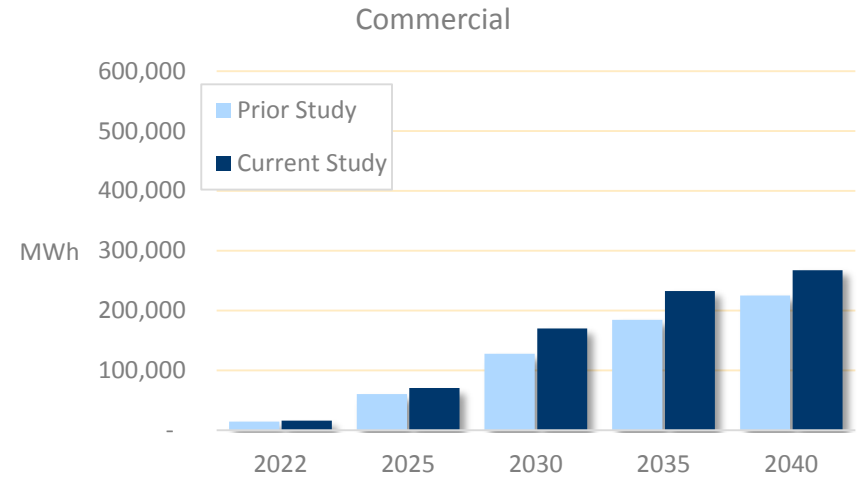
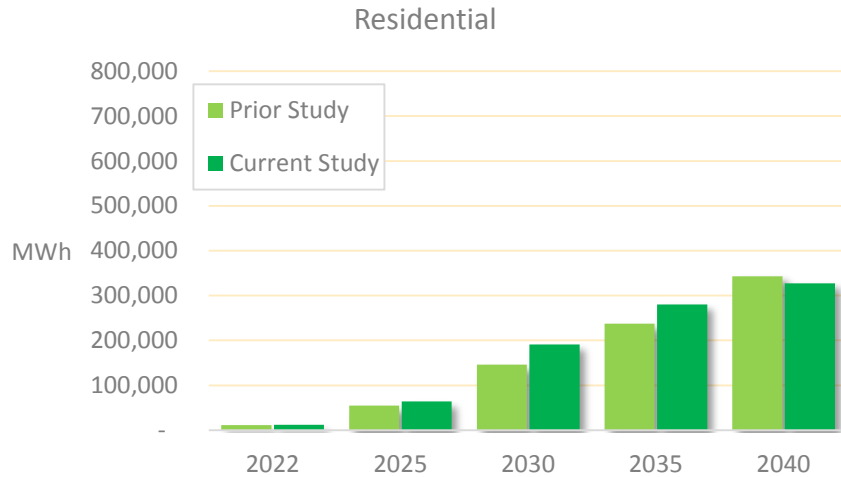

- 2020 savings already removed from prior study values

# SECTOR-LEVEL NOTES

## Comparison with Prior Potential Study – **Technical Achievable**

---

### Residential:

- LED share of interior lighting market baseline continues to grow, reducing available potential from turnover of old units
  - This limits the extra potential Idaho gets from not having the EISA backstop in place
- HPWH savings have been revised slightly downward

### Commercial:

- Decreases in interior lighting potential as base LED share grows in interior lighting; accelerated turnover and ramp rate compensates, but not completely
- Increased refrigeration potential from new and emerging measures, updated RTF workbooks
- HVAC retrocommissioning and controls (e.g. Strategic Energy Management systems) greatly expanded applicability in 2021 plan compared to prior study

### Industrial:

- Increased potential in motors from updated retrofit applicability in 2021 plan

# NEXT STEPS

---

- AEG has provided measure list and assumption appendices for EE to Avista for circulation
- Electric IRP will evaluate cost effective portfolio based on AEG provided savings and levelized costs
- Gas IRP will run with AEG-provided UCT cost effective potential



THANK YOU!

Ingrid Rohmund, Sr. Vice President, Consulting  
[irohmund@appliedenergygroup.com](mailto:irohmund@appliedenergygroup.com)

Ken Walter, Project Manager  
[kwalter@appliedenergygroup.com](mailto:kwalter@appliedenergygroup.com)

Kelly Marrin, Managing Director  
[kmarrin@appliedenergygroup.com](mailto:kmarrin@appliedenergygroup.com)

Tommy Williams, Lead Analyst  
[twilliams@appliedenergygroup.com](mailto:twilliams@appliedenergygroup.com)





# Supplemental Slides

# NWPCC 2021 PLAN RAMP RATES

## NWPCC 2021 Plan Retrofit Ramp Rates

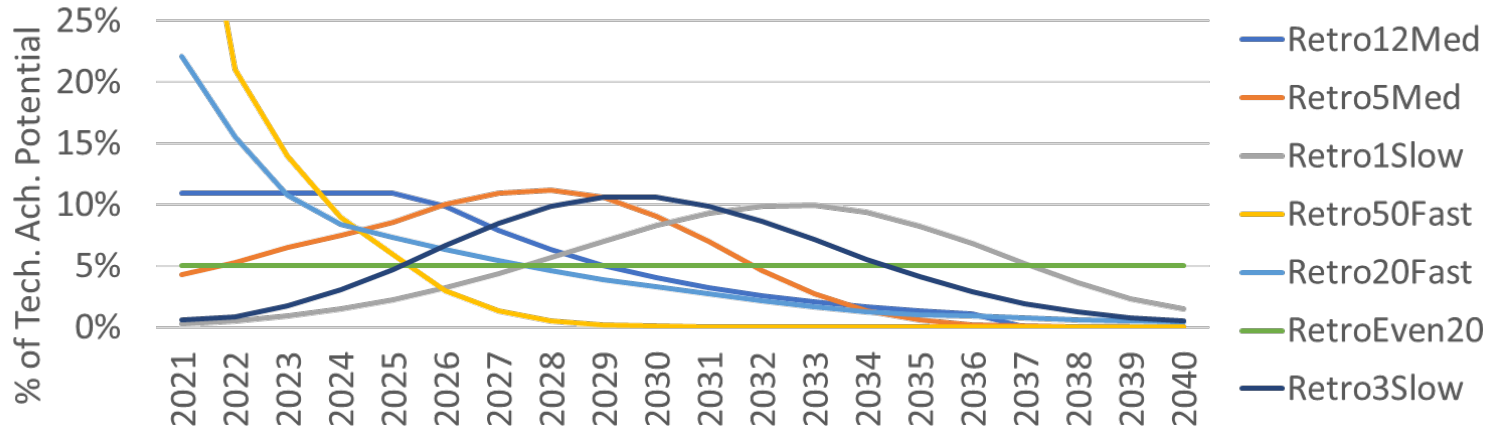

## NWPCC 2021 Plan Lost Opp. Ramp Rates

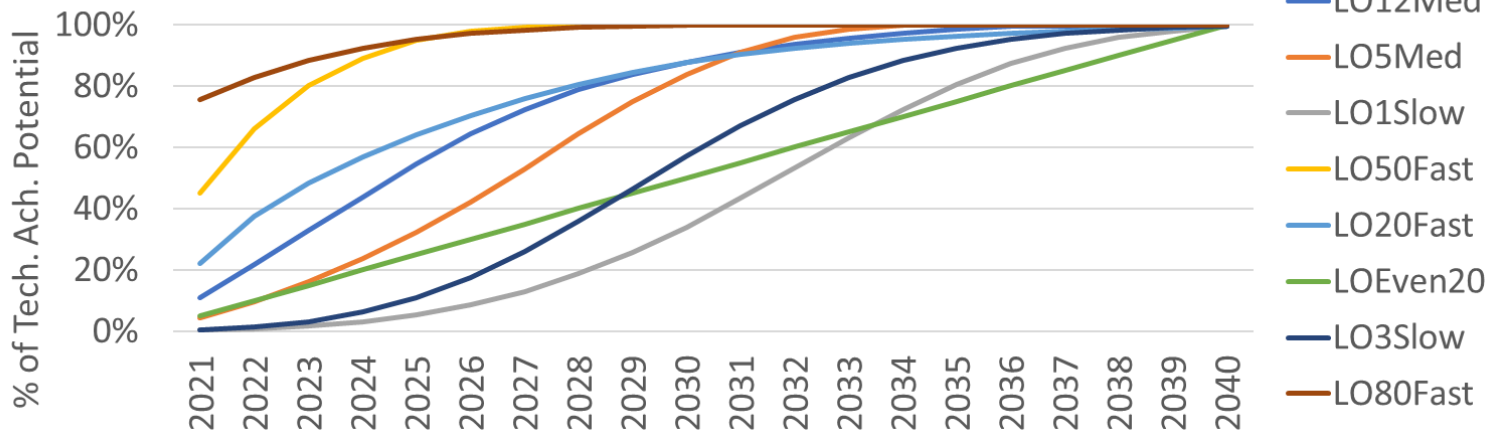

# EE RAMP RATE CHANGES

Sector(s)	Measure Category	Equipment or Non-Equip	2019 CPA Ramp Rate	2021 Plan Ramp Rate
Res	Appliances	Equipment	LO1Slow	LO12Med
Res	Building Shell	Non-Equipment	Retro12Med	Retro5Med
	Energy Kits	Non-Equipment	Aerators: Retro3Slow, SH:	Retro3Slow
Res			Ret12Med	
Res	HVAC	Equipment	LO5Med CAC, LO1Slow RAC	LO5Med CAC, LO12Med RAC
Res	HVAC	Non-Equipment	Thermostat&DHP Retro5Med,	Thermostat&DHP
Res			Retro3Slow	Retro5Med, Retro5Med
Res	Lighting	Equipment	LO12Med & LO20 Fast	LO20Fast
Res	Water Heating	Equipment	LO3Slow	LO5Med
Res	Whole Home	Non-Equipment	LOEven20	NA
Res	Electronics	Non-Equipment	Retro3Slow	Retro3Slow

Sector(s)	Measure Category	Equipment or Non-Equip	2019 CPA Ramp Rate	2021 Plan Ramp Rate
C&I	Building Shell	Non-Equipment	RetroEven20	Retro1Slow
C&I	Compressed Air	Both	Retro5Med, Retro12Med	Retro5Med, Retro12Med
C&I	Energy Management	Non-Equipment	Retro12Med	Retro5Med
C&I	Food Service Equipment	Equipment	LO5Med, LO12Med	LO3Slow, LO1Slow
C&I	HVAC	Equipment	LO5Med, LO20Fast	LO5Med, LO12Med
	HVAC	Non-Equipment	RetroEven20, Retro12Med,	Retro12Med, Retro5Med
C&I			Retro3Slow, Retro1Slow	
C&I	Irrigation	Non-Equipment	Retro12Med mostly	RetroEven20
C&I	Lighting	Equipment	LO20Fast/LO50Fast	LO80Fast
C&I	Motors	Non-Equipment	Retro12Med	Retro12Med
C&I	Refrigeration	Both	Retro12Med	Retro5Med

- Several residential categories were adjusted to faster ramp rates
- C&I changes mostly slowed adoption, except for lighting which is greatly accelerated and non-equipment HVAC (maintenance, tune ups, etc) which accelerated

Legend:  
 Faster Ramp  
 Slower Ramp  
 No Change  
*\*compared to 2019 CPA Ramps*

# DEFINITIONS OF POTENTIAL

## Cumulative and Incremental

---

Over the following slides, we will display potential both as a **cumulative** impact on baseline as well as in annual **increments**

**Cumulative** potential includes the impacts of potential acquired from the first year of the study period (2022) through the year of interest, including effects of measures persistence

**Incremental** potential summarizes new impacts realized in any given year of interest, excluding the effects of measure repurchases



# Electric Wholesale Market Price Forecast

James Gall, Electric IRP Manager  
Third Technical Advisory Committee Meeting  
September 29, 2020

# Market Price Forecast – Purpose

- Estimate “market value” of resources options for the IRP
- Estimate dispatch of “dispatchable” resources
- Helps estimate avoided costs
- May change resource selection if resource production is counter to needs of the wholesale market

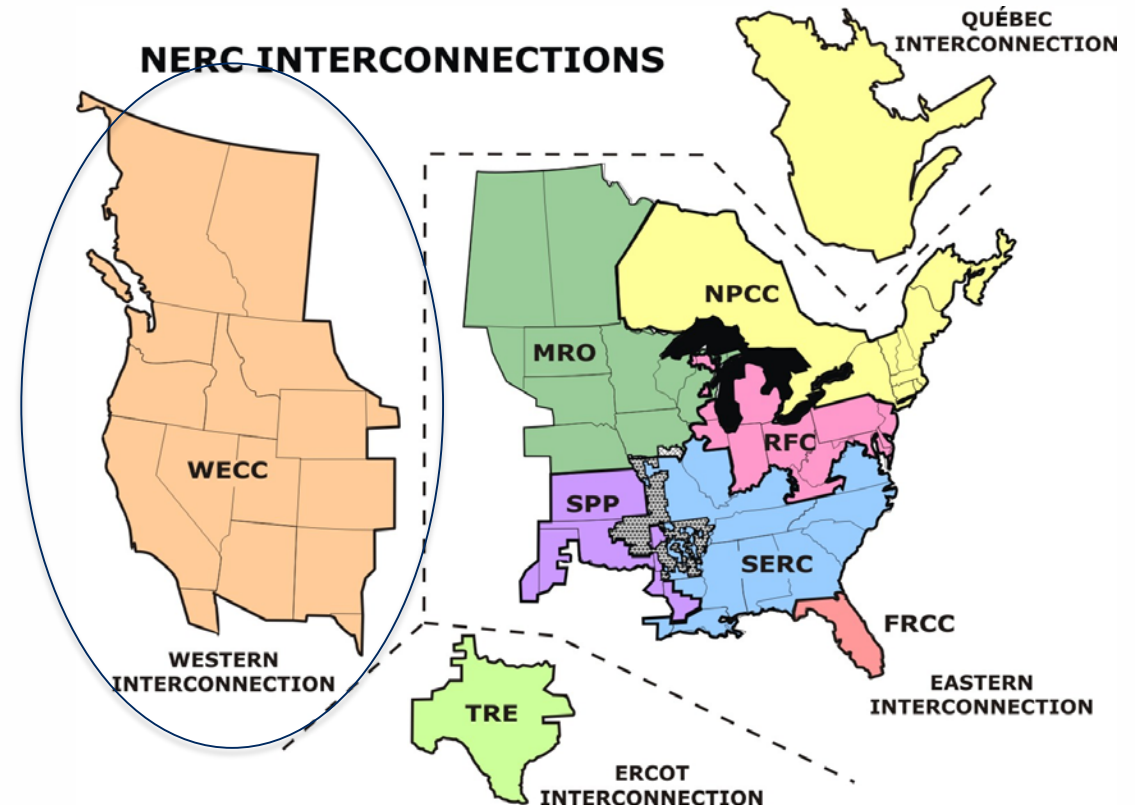

Source: NERC  
2021 Electric IRP Appendices

# Methodology

- 3<sup>rd</sup> party software- Aurora by Energy Exemplar
- Electric market fundamentals- production cost model
- Simulates generation dispatch to meet regional load
- Outputs:
  - Market prices (electric & emission)
  - Regional energy mix
  - Transmission usage
  - Greenhouse gas emissions
  - Power plant margins, generation levels, fuel costs
  - Avista’s variable power supply costs

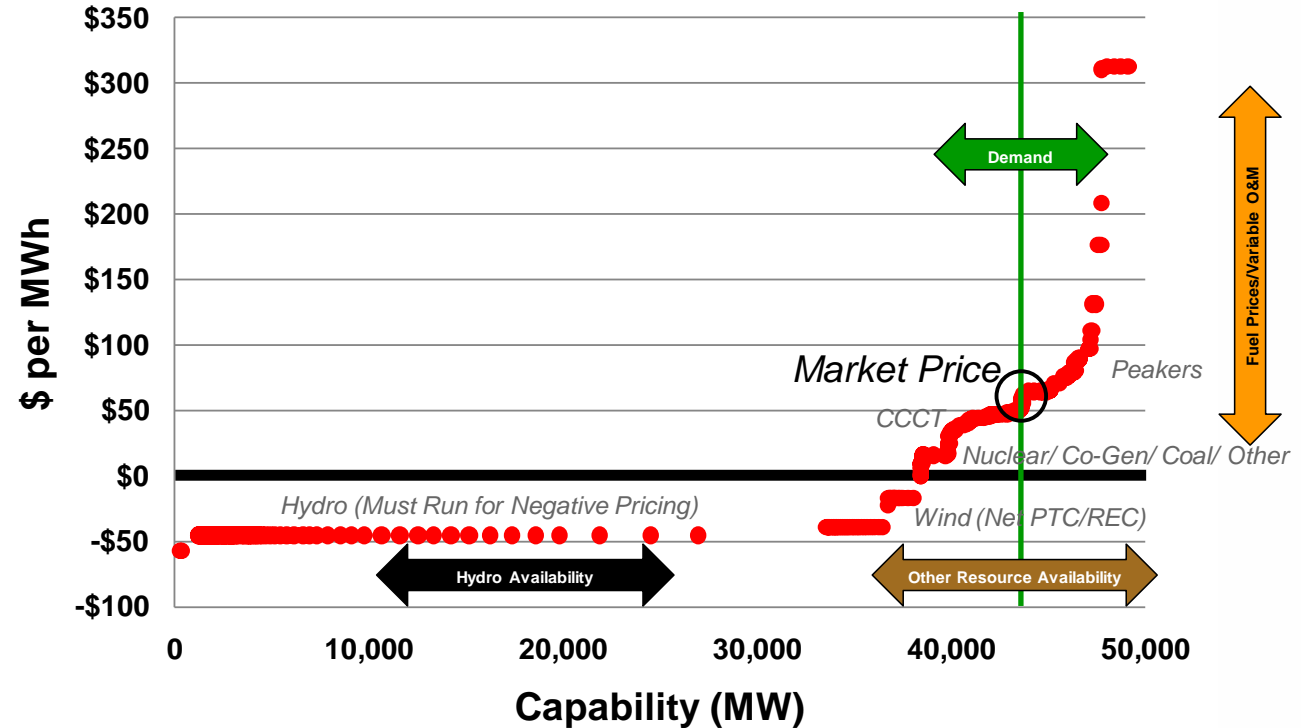

Note: minimum price is negative \$25/ MWh (2018\$)

# Wholesale Mid-C Electric Market Price History

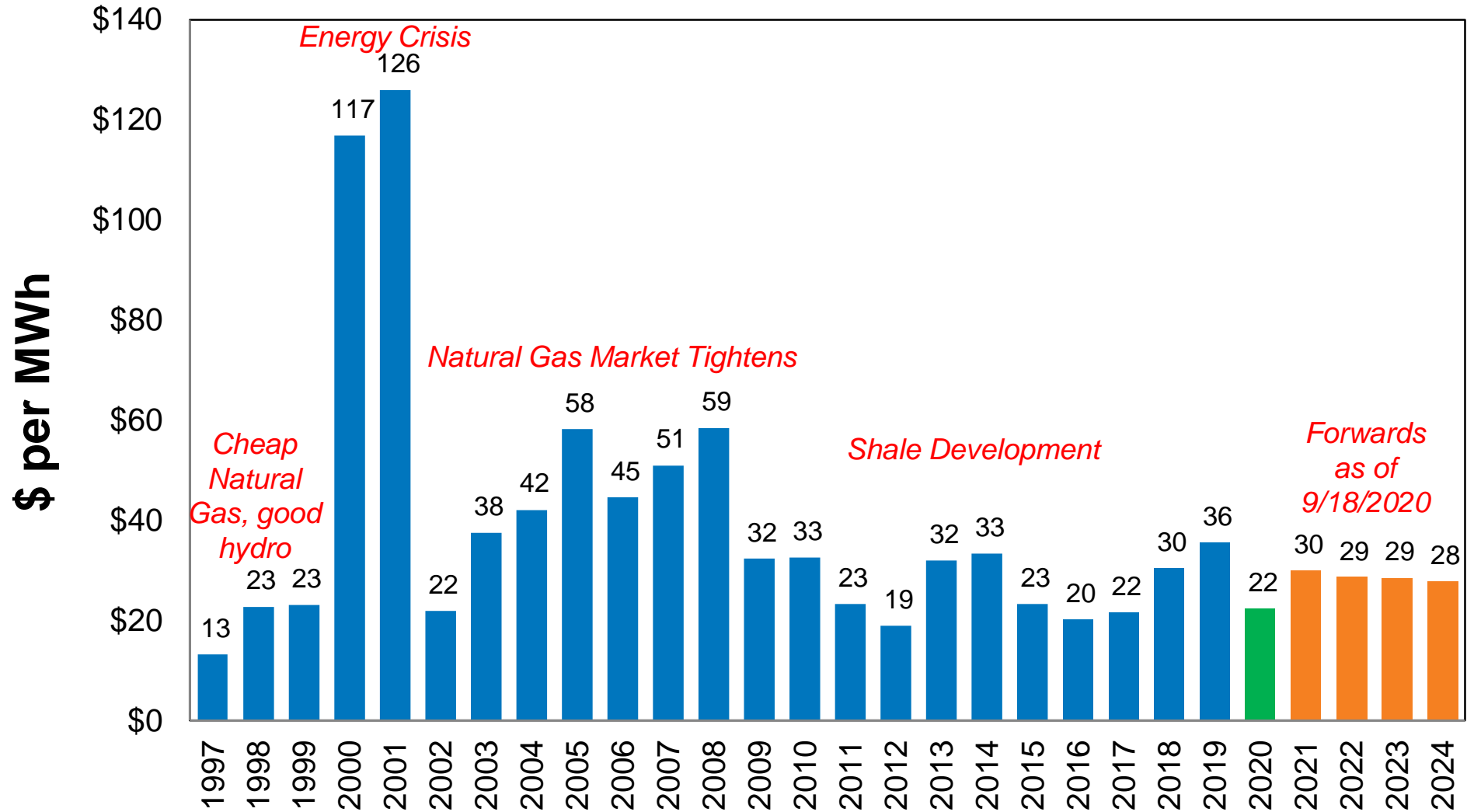

2021 Electric IRP Appendices



# U.S. Western Interconnect Generation Mix

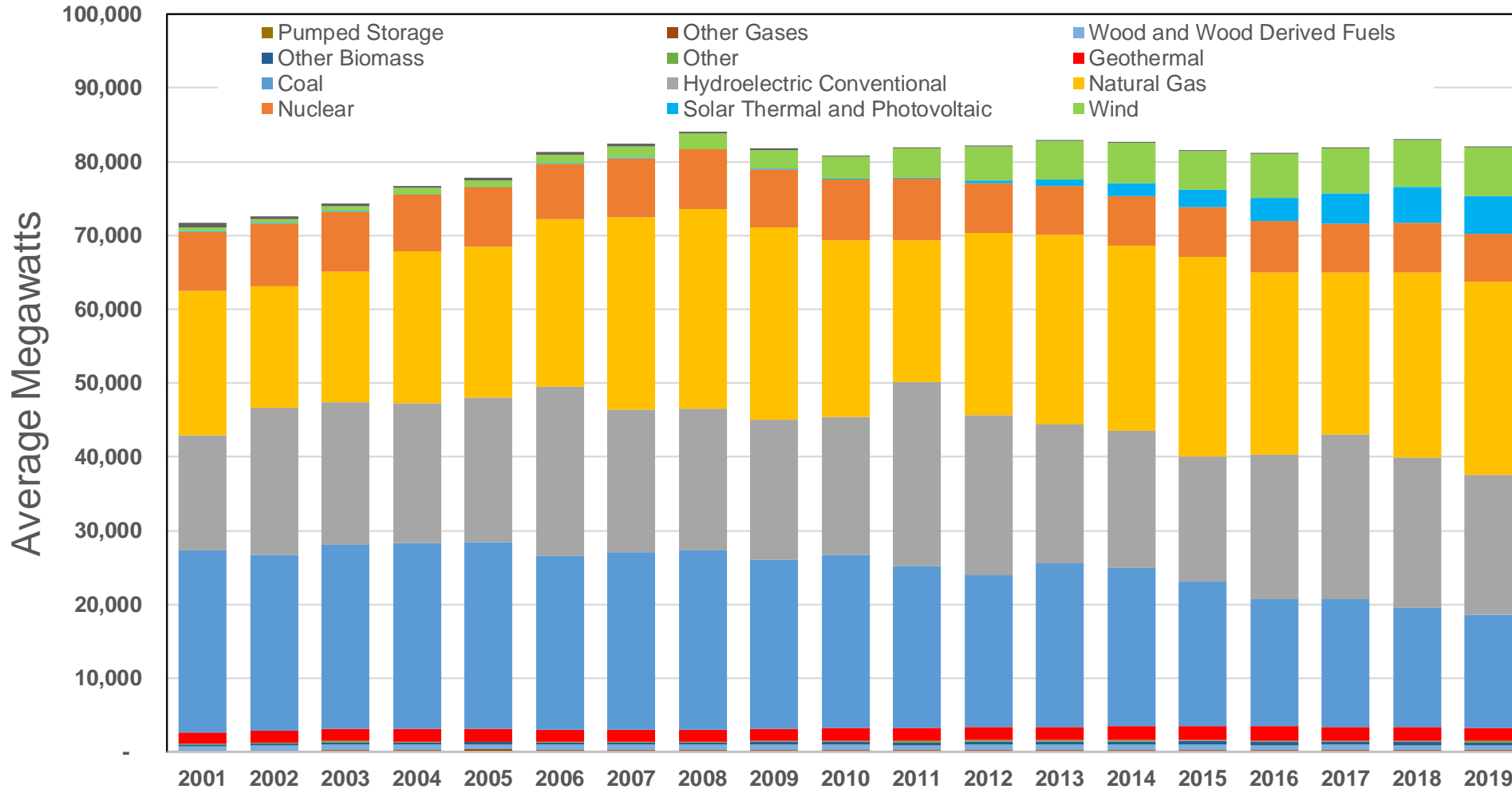

## Significant changes (aGW)

Solar: + 5.0  
 Wind: + 6.2  
 Nat Gas: + 6.5  
 Coal: - 9.3  
 Nuclear: - 1.5  
 Total: + 11.0

Hydro: -4.2 / +5.2

# Northwest Generation Mix (ID, MT, OR and WA)

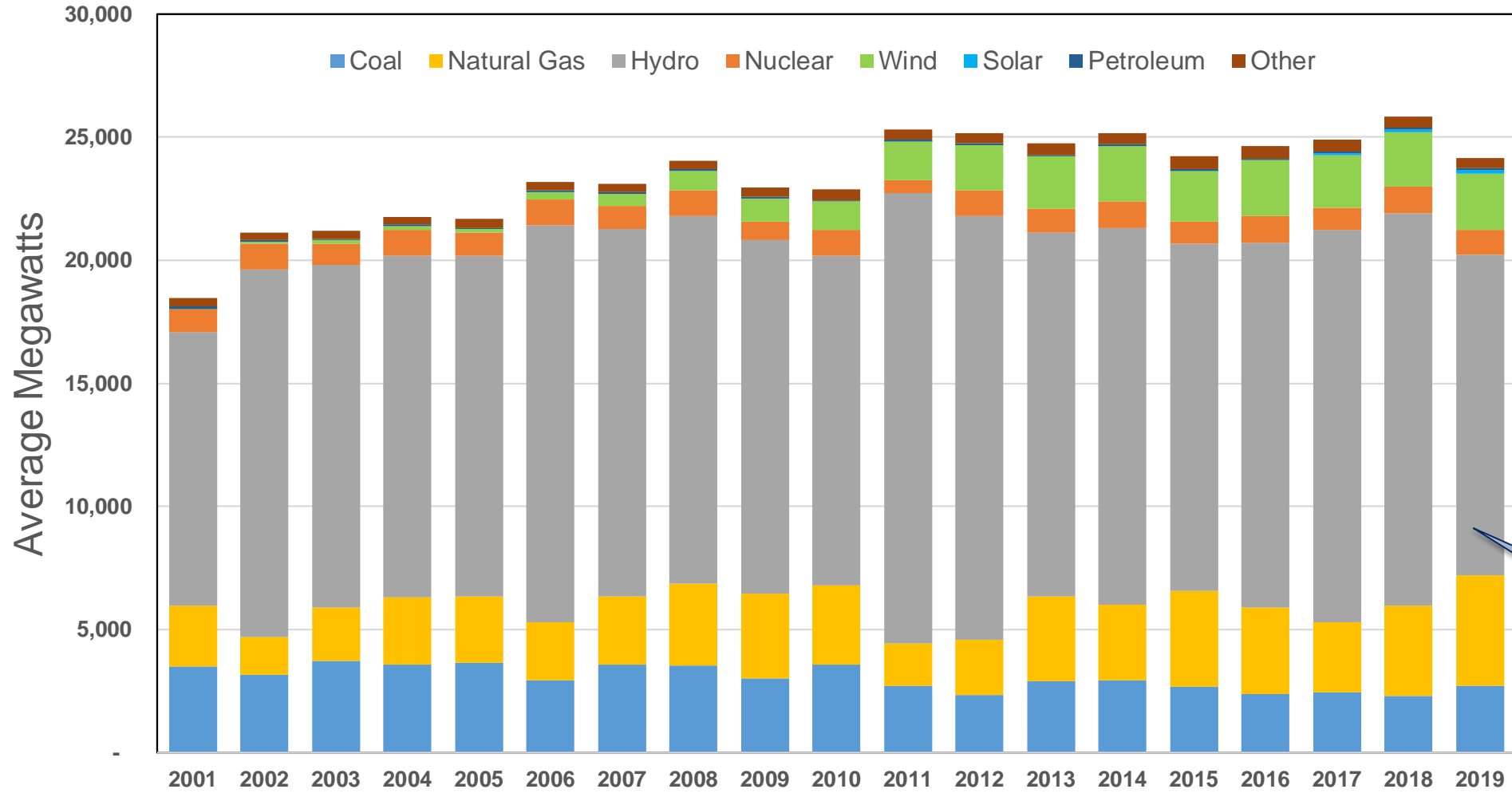

## Significant changes (aGW)

Solar: + 0.1  
 Wind: + 2.3  
 Nat Gas: + 2.0  
 Coal: - 0.8  
 Total: + 5.7

Hydro: -3.7 / +3.5

2019 2.0 aGW less than 2002-2018 Avg

# 2019 Fuel Mix

## Northwest

70% GHG Emission Free\*

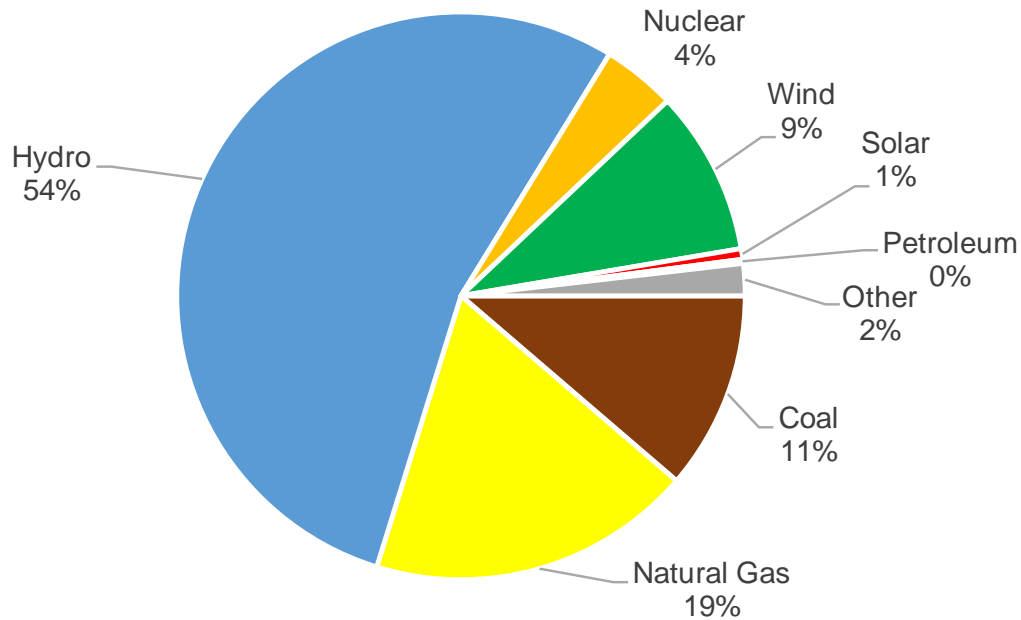

## U.S. Western Interconnect

49% GHG Emission Free

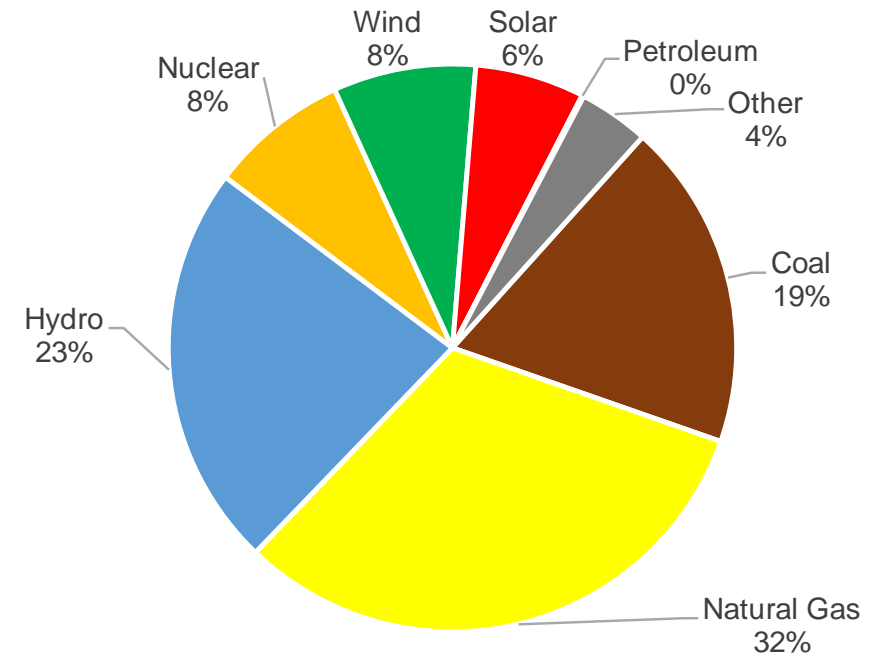

Source: EIA  
Avista Corp.

\* Low hydro year dropped emission free statistic from 77% in 2018 to 70% in 2019

# Market Indicators- Market is Tightening

Daily NG vs On-Peak Electric

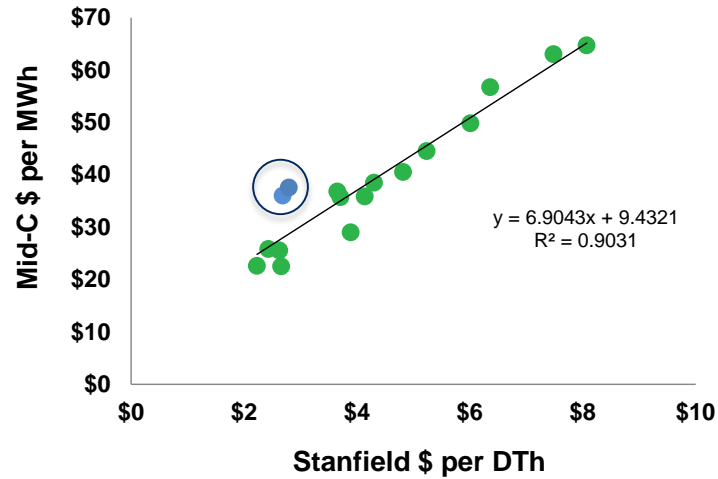

Spark Spread

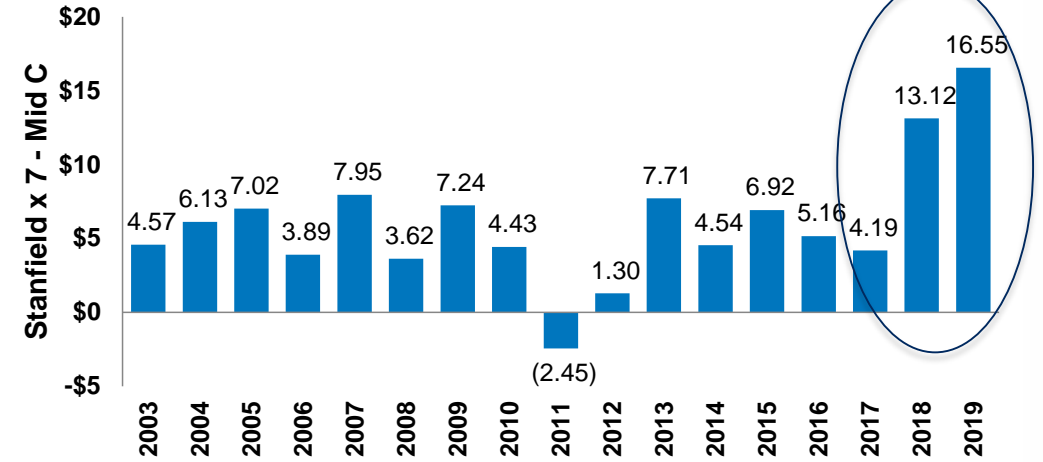

Implied Market Heat Rate

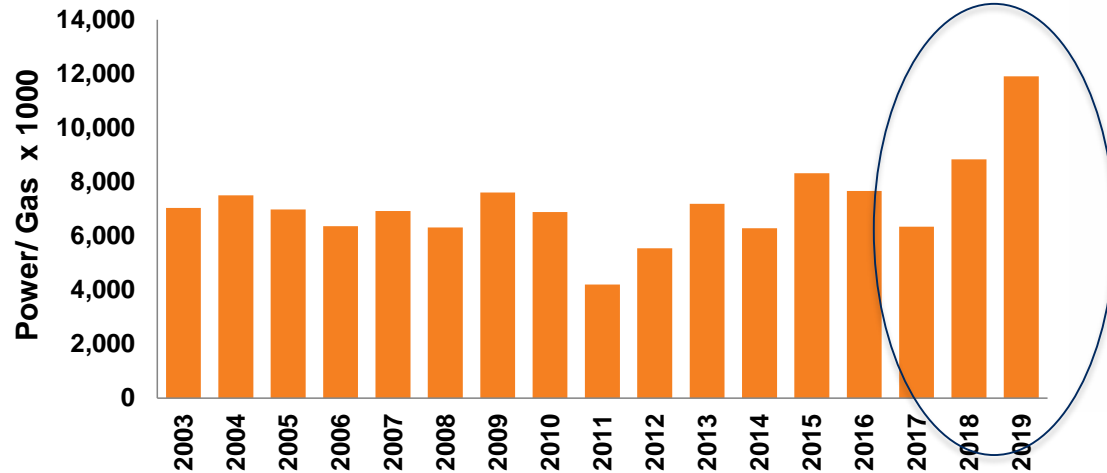

Daily Mid-C Price Standard Deviation

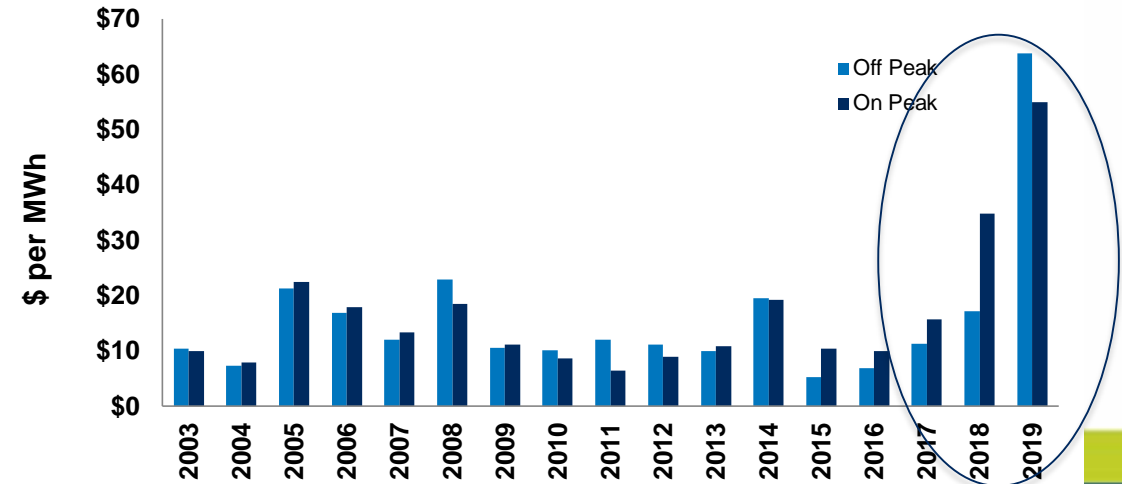

# US Western GHG Emission End Use

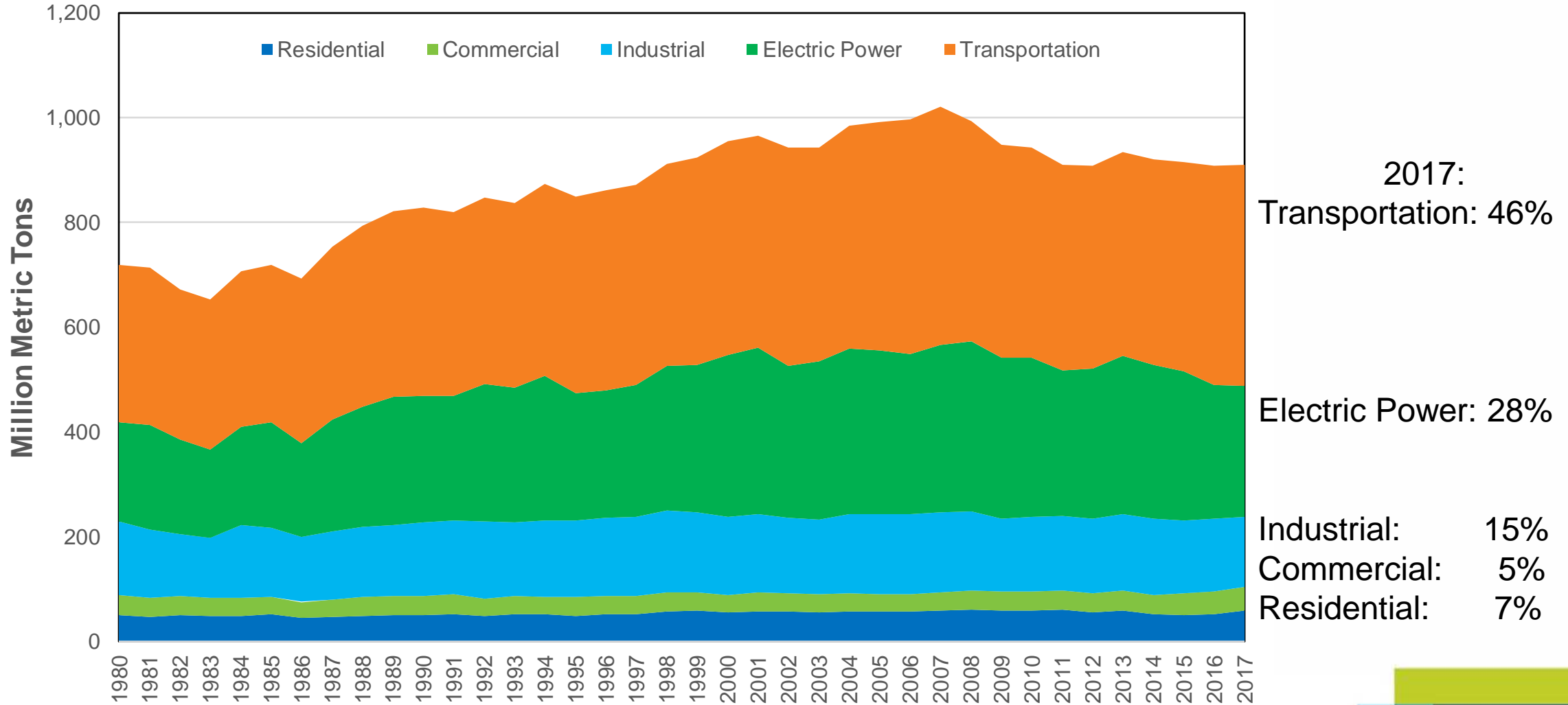

Source: EIA  
Avista Corp.

# Electric Greenhouse Gas Emissions U.S. Western Interconnect

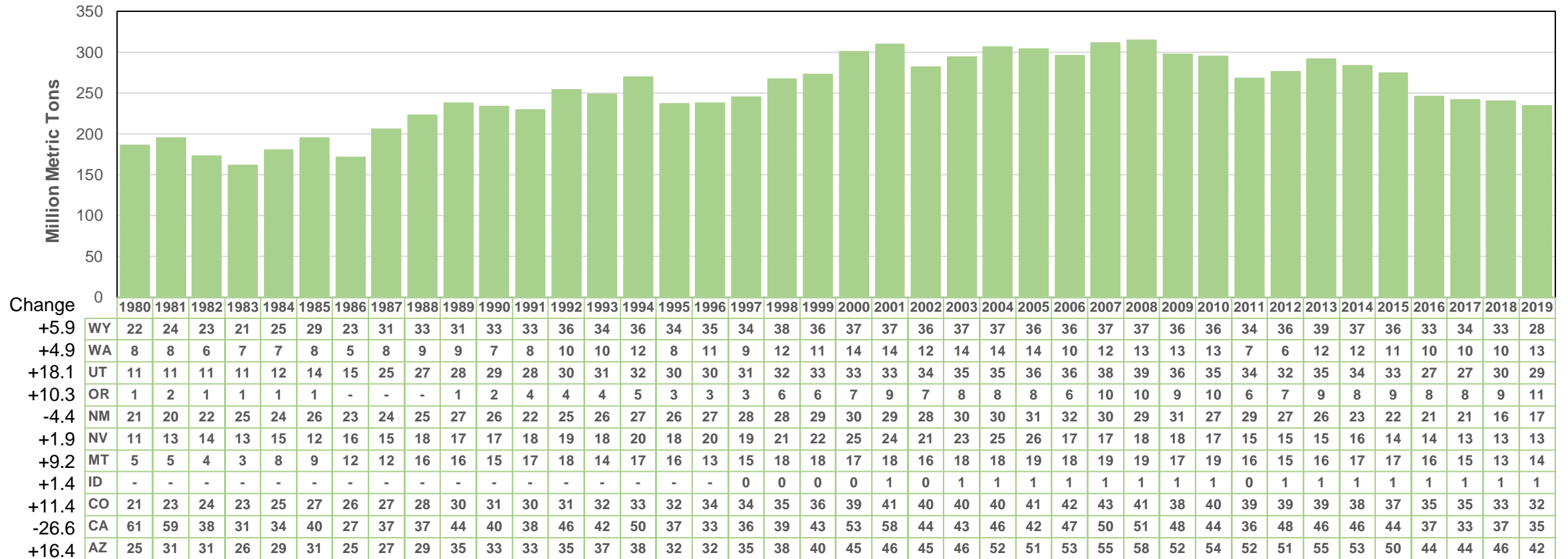

Emissions are adjusted for generation within the Western Interconnect  
2018 and 2019 estimates are subject to adjustment

# Northwest Greenhouse Gas Emissions

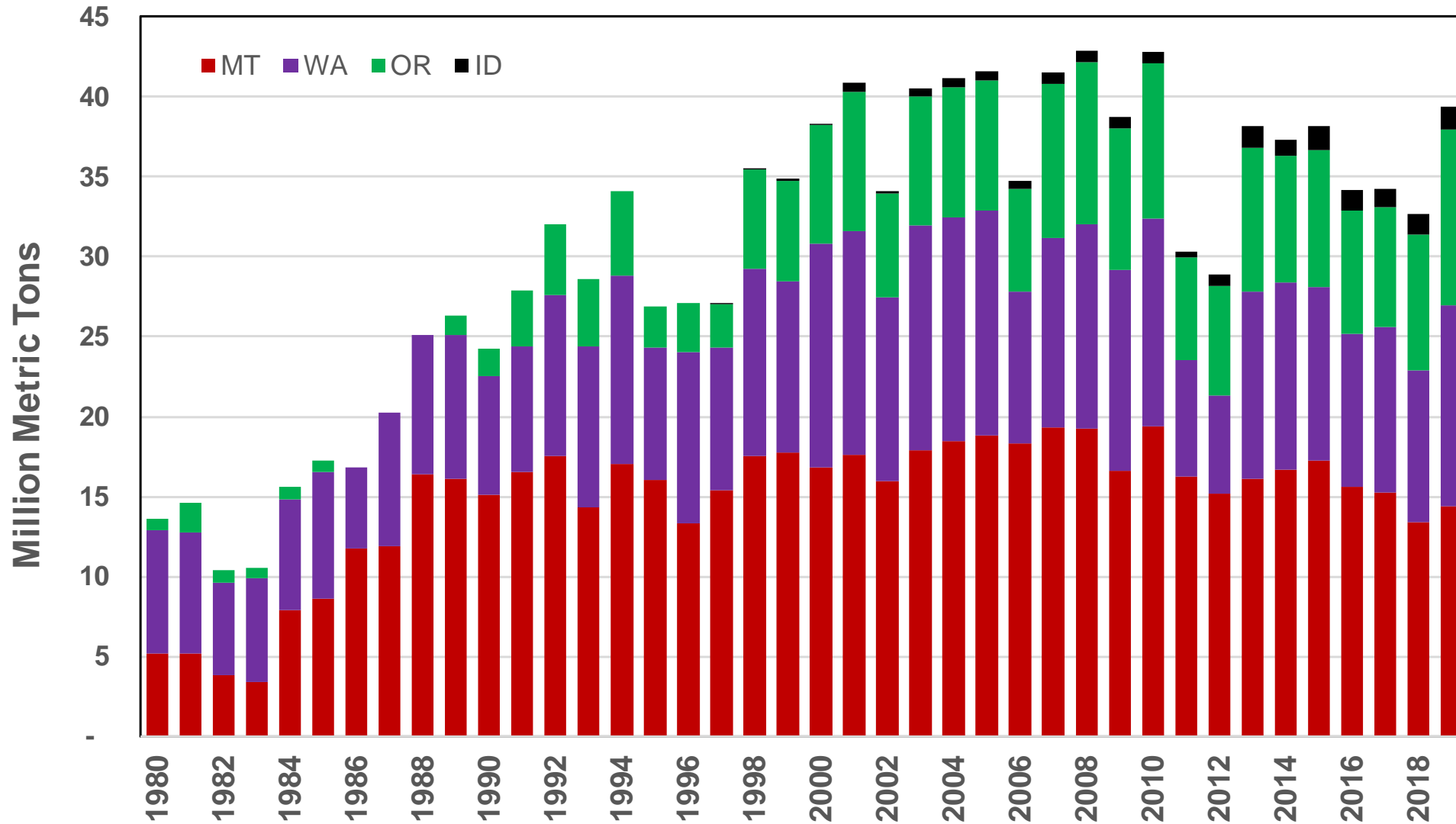

2021 Electric IRP Appendices

# The Forecast: 2022 to 2045

## Deterministic Model

- Simulate based on average conditions
- 210,240 hours simulation
- Takes about 6 hours on one processor
- Good approximation to estimate impacts of assumptions- great for scenario analysis, but not risk
- Output Files: 26 GB

## Stochastic Model

- Simulate 500 varying conditions
- Fuel Prices, Loads, Wind, Hydro, Outages, Inflation
- 105 million hours of simulation
- Takes about 5 days on 33 processors
- Allows for full evaluation of resource alternatives and accounts for risk
- Output Files: 360 GB



# Modeling Process

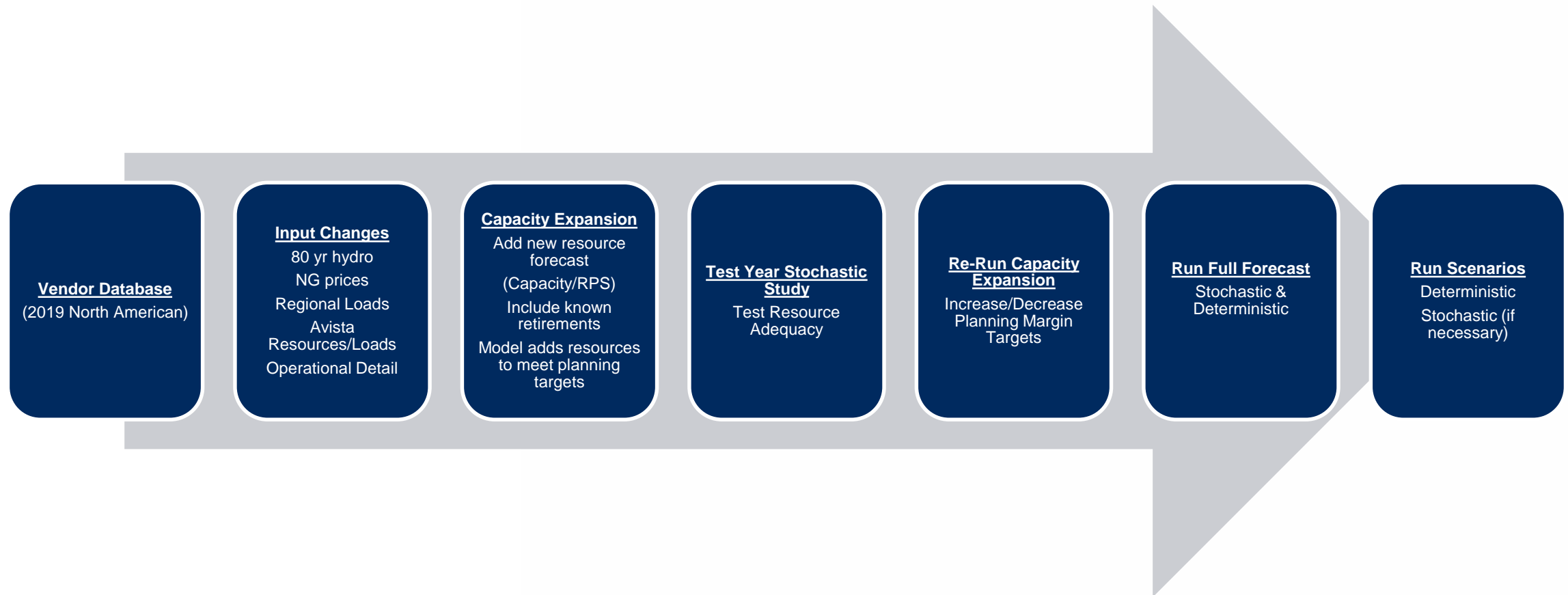

# Load Forecast

- Regional load forecast from 'IHS
  - Forecast includes energy efficiency
- Add net meter resource forecast
  - Input annually with hourly shape
- Add electric vehicle forecast
  - Input annual with hourly shape
- Future load shape to be different than today's load shape

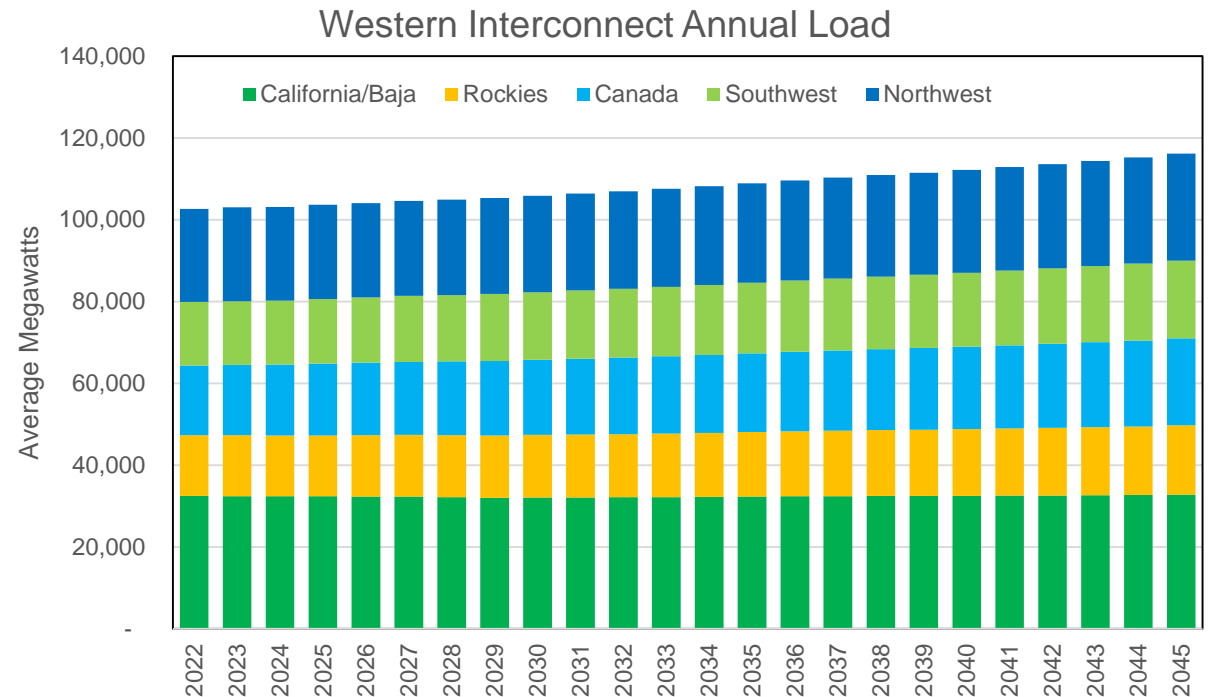

# Electric Vehicle and Solar Adjustments

## Roof Top Solar

- EIA existing estimates for history
- IHS regional growth rates

Western Interconnect Rooftop Solar Capability

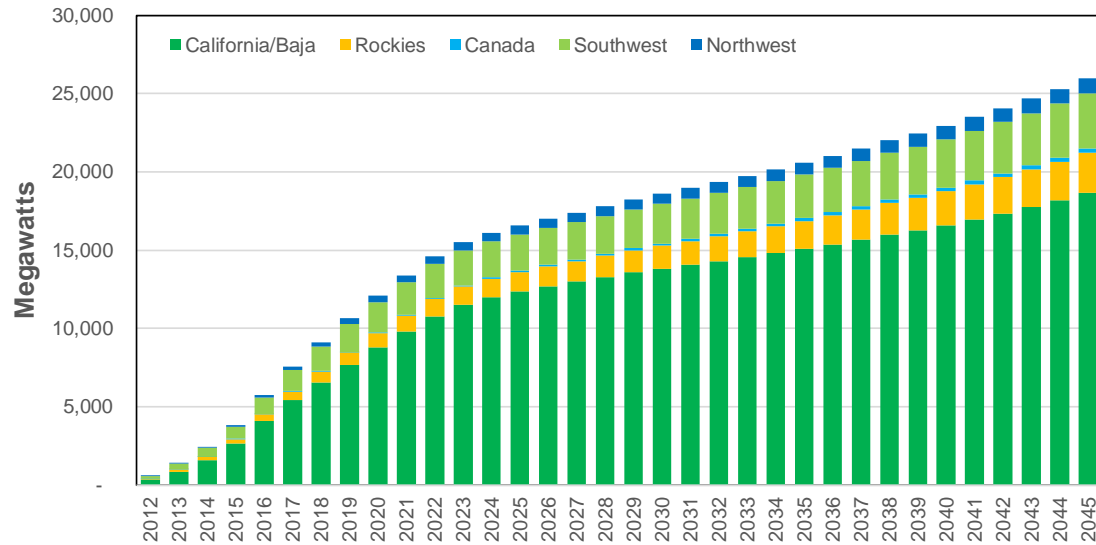

## Electric Vehicles

- Penetration rates increase each year (2040 shown below)
- 15-30% light duty
- 12-15% medium duty
- 5% heavy duty

Western Interconnect Transportation Electrification

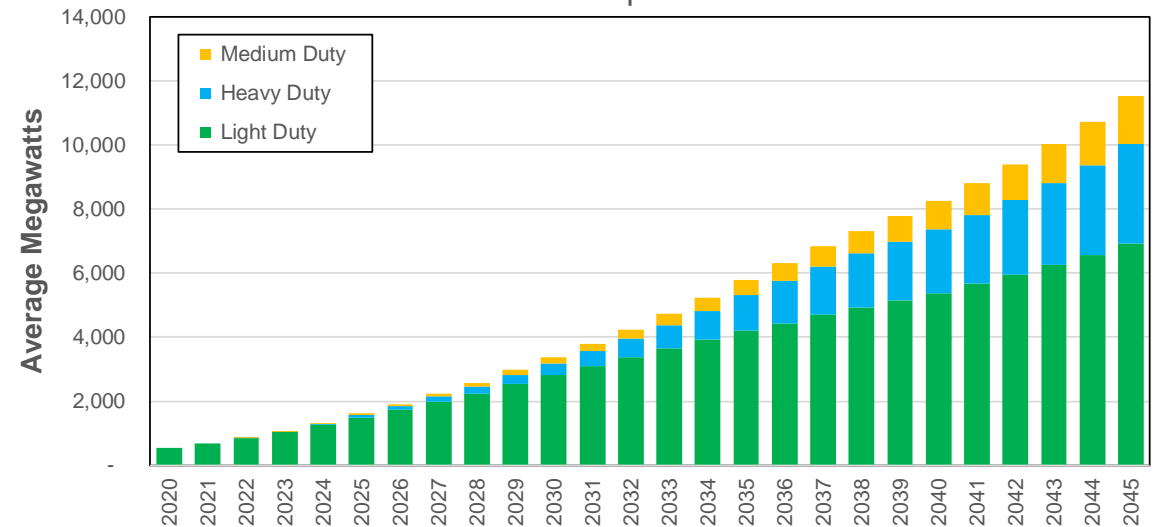

# New Resource Forecast (Western Interconnect)

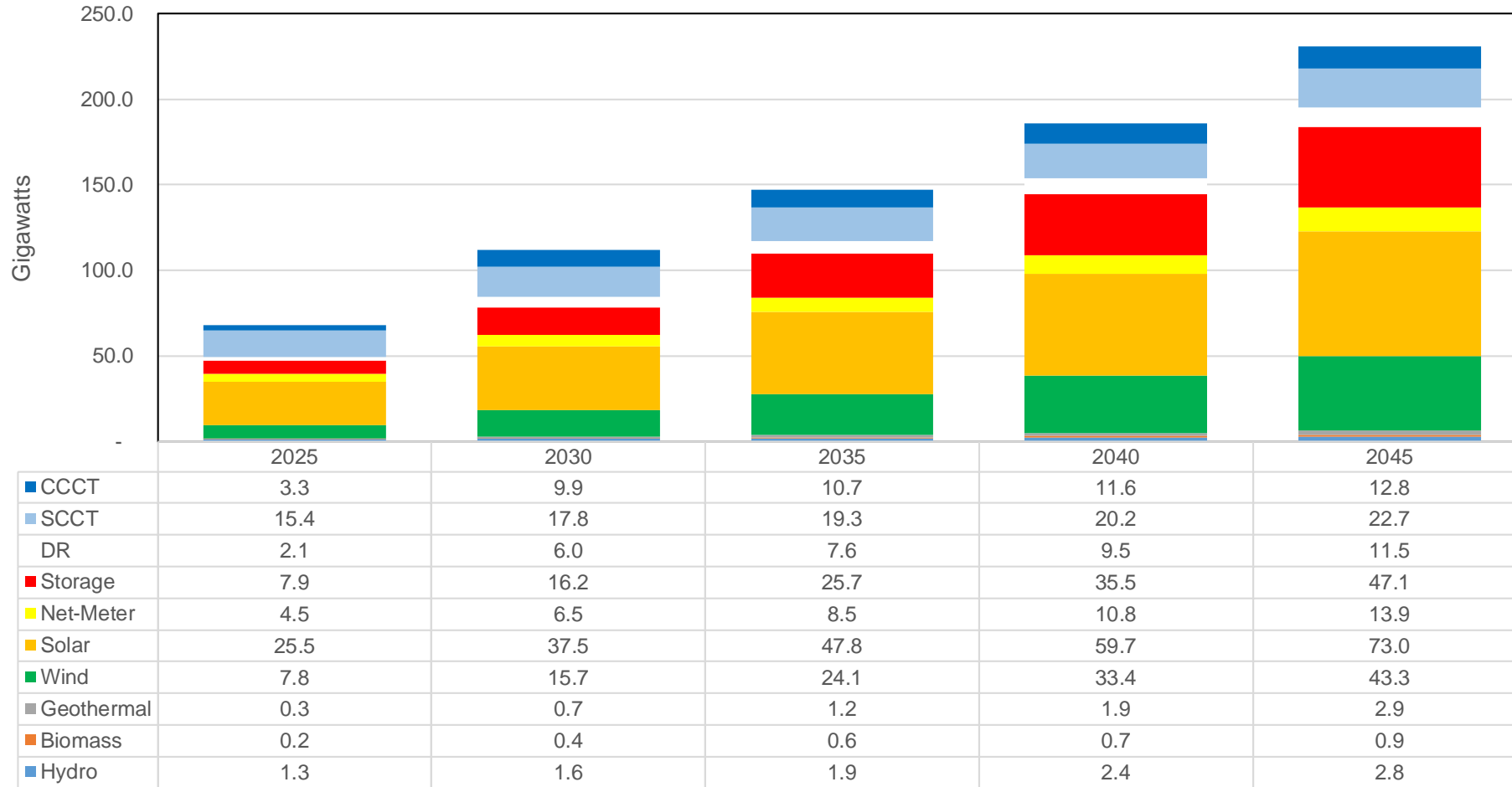

# U.S. West Resource Type Forecast

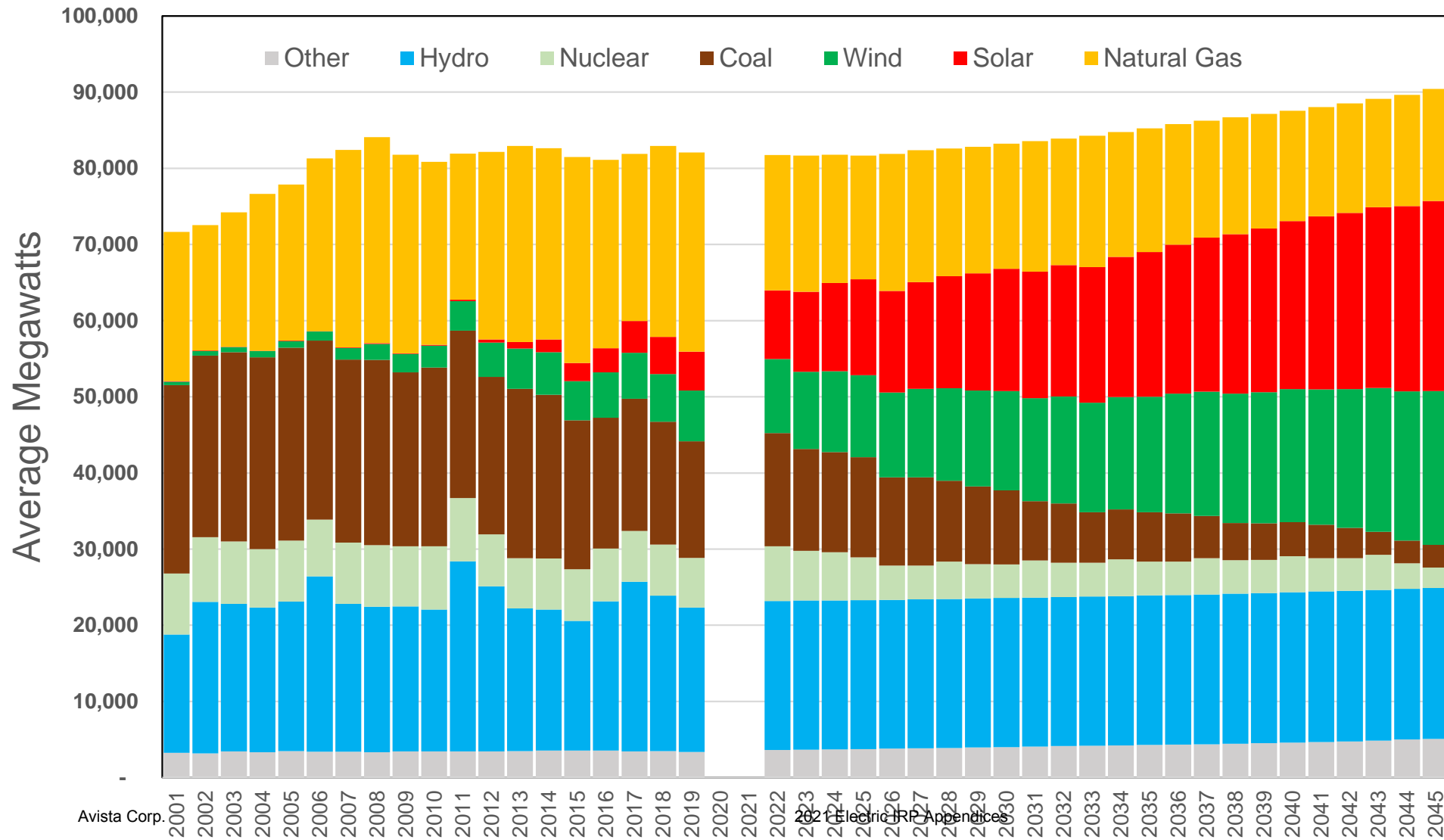

Significant changes  
2045 to 2022 (aGW)

Solar:	+ 15.9
Wind:	+ 10.5
Nat Gas:	- 3.1
Coal:	- 11.9
Nuclear:	- 4.5
Other:	+ 1.5
Hydro:	+ 0.3
<b>Total:</b>	<b>+ 11.9</b>

# Northwest Resource Type Forecast

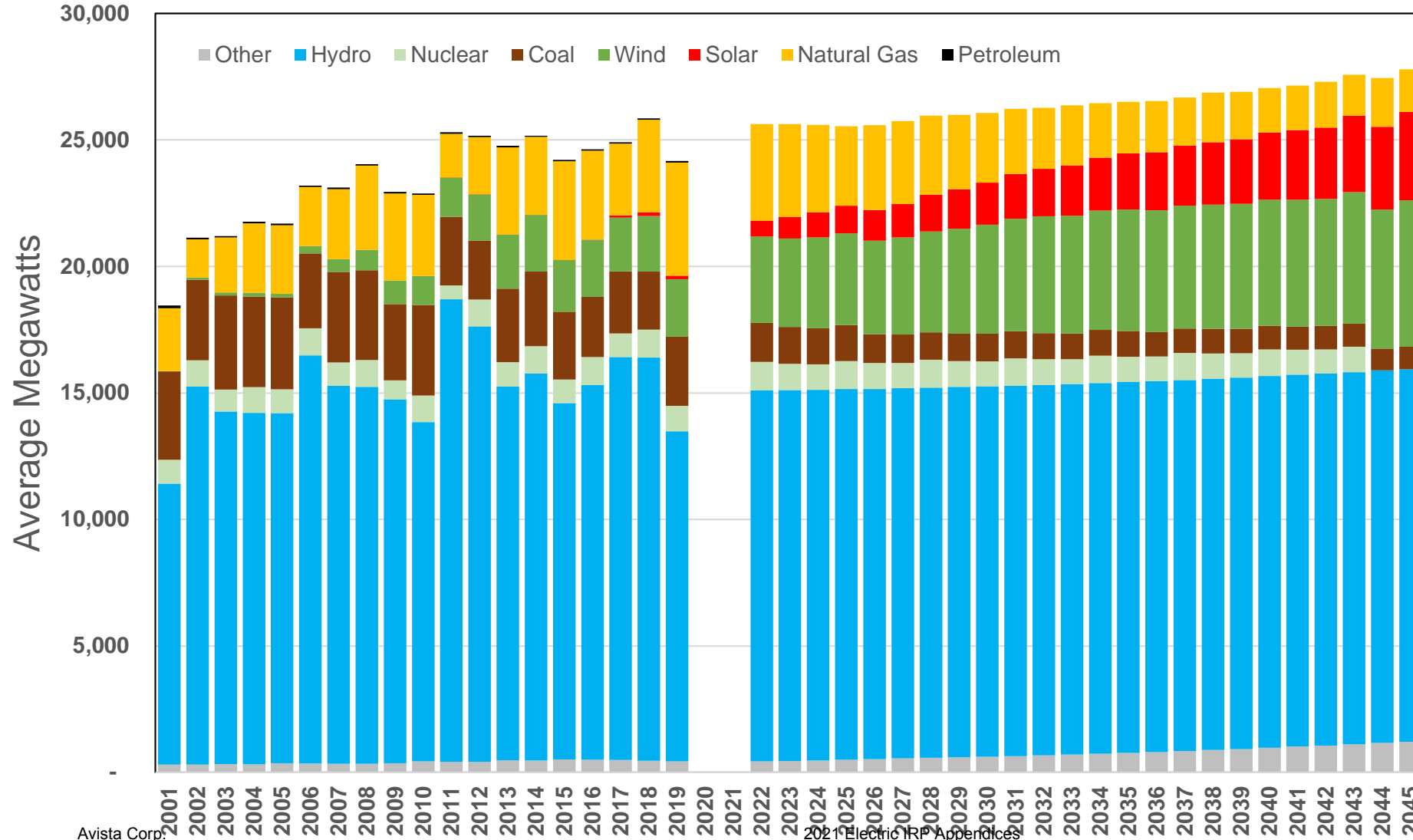

Significant changes (aGW)  
2045 to 2022

Solar: + 2.9  
 Wind: + 2.4  
 Nat Gas: - 2.1  
 Coal: - 0.6  
 Other: + 0.7  
 Nuclear: - 1.1  
 Total: + 2.2

# Mid-C Electric Price Forecast

Mid-Columbia Electric Forecast (Deterministic)

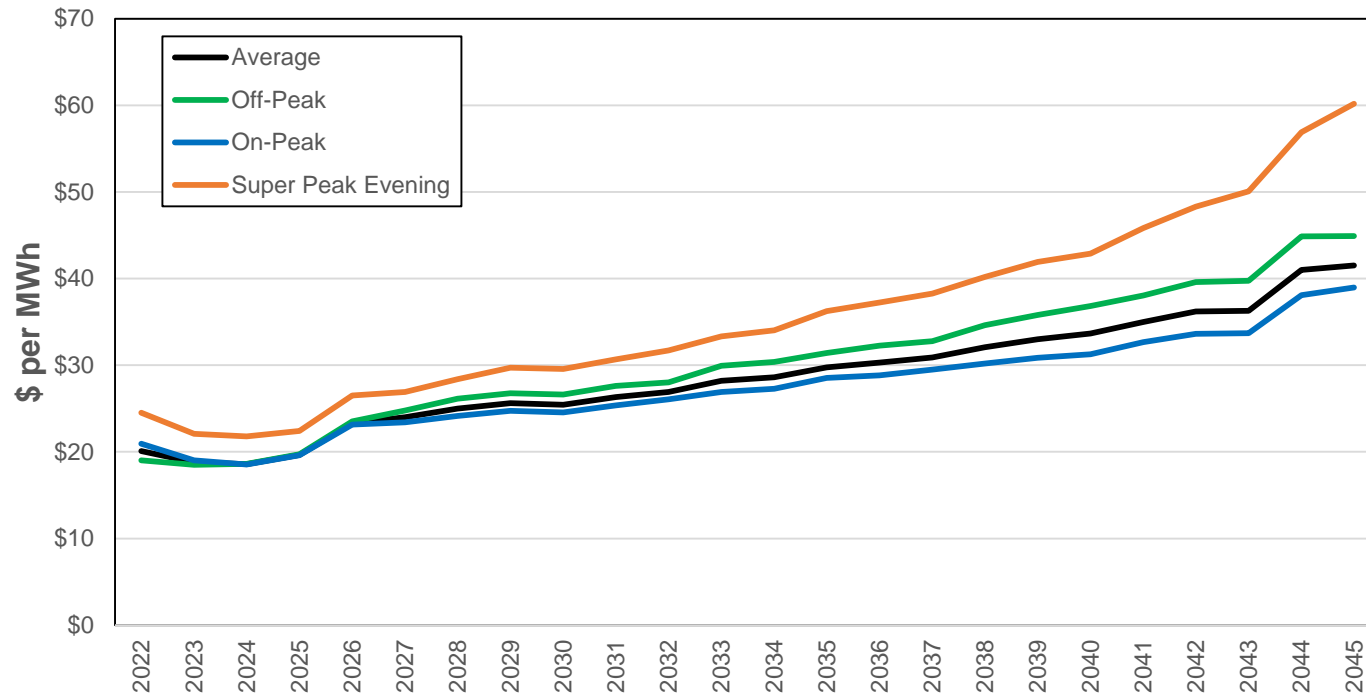

- Levelized Prices:
  - 2022-45: \$26.05/MWh
  - 2022-41: \$23.03/MWh
- Off-peak prices over take on-peak in 2024 on an annual basis
- Evening peak prices remain high (4pm-10pm)

# Mid-C Price Forecast (Stochastic- Draft)

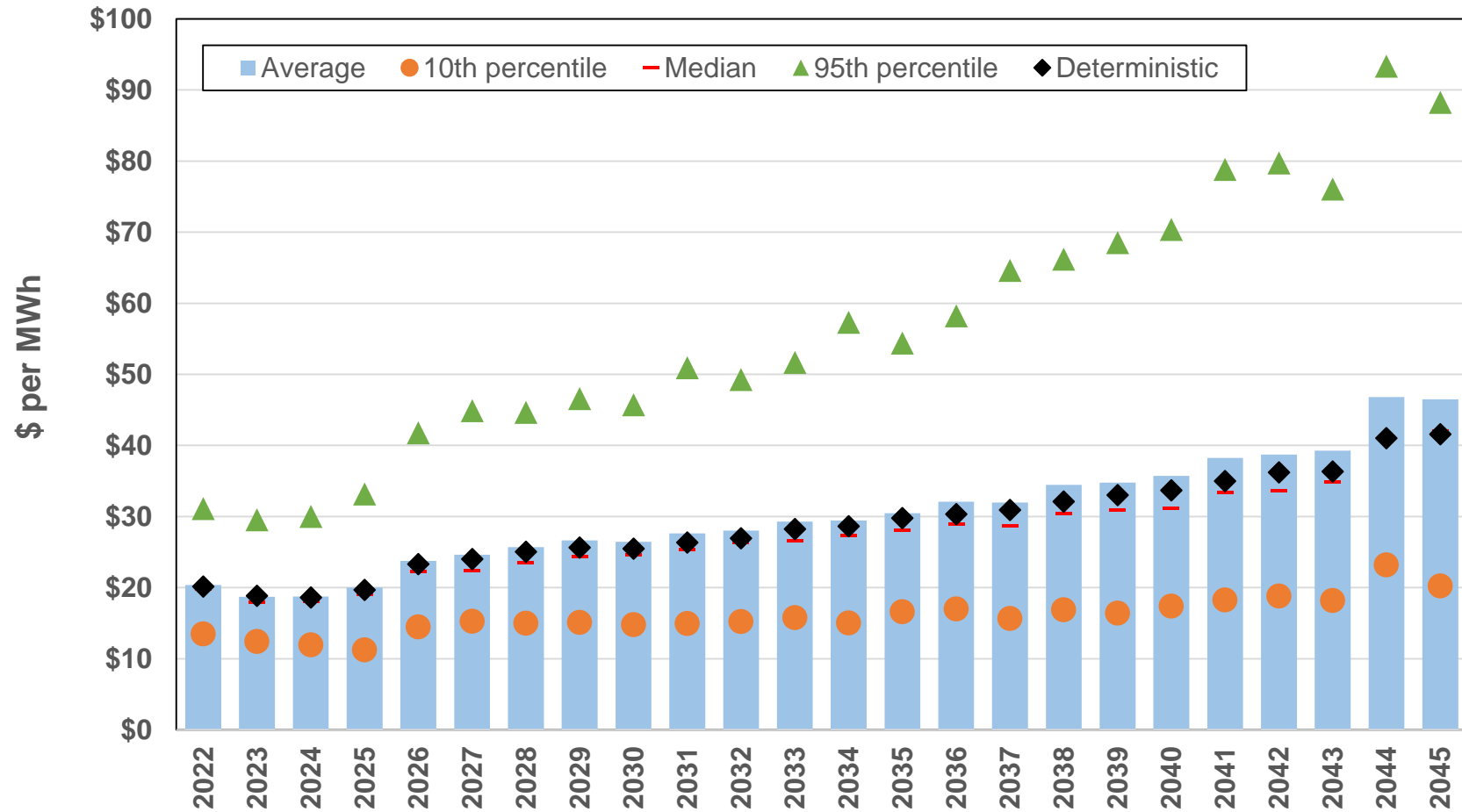

## 24-yr Levelized Prices

Mean: \$27.11/MWh

Median: \$24.84/MWh

Deterministic: \$26.05/MWh



# Mid-C Electric Price Comparison vs. Previous IRPs

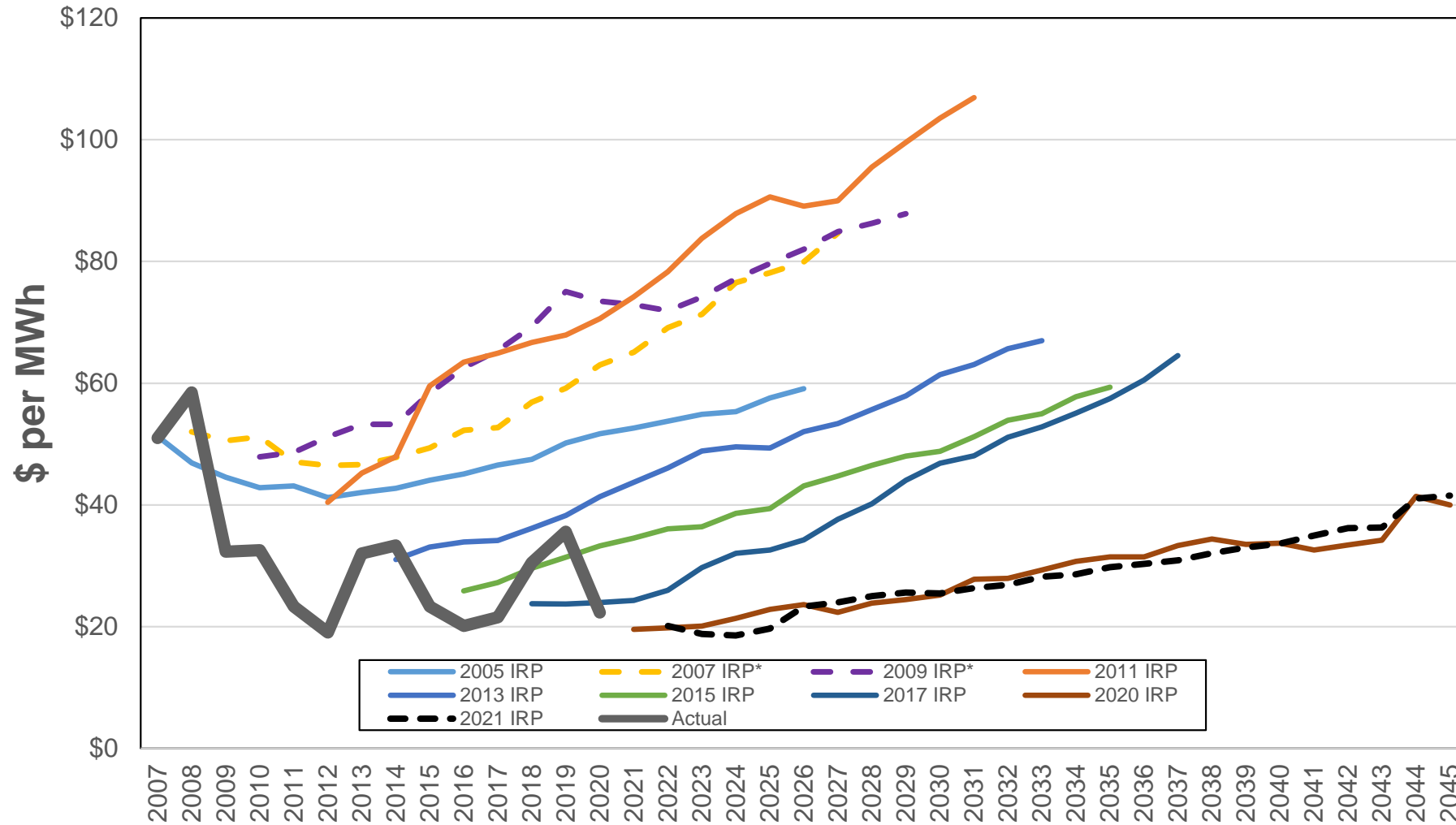

\* These forecasts use price scenarios without GHG "taxes" to make all forecasts consistent

2021 Electric IRP Appendices

# Hourly Wholesale Mid-C Electric Price Shapes

Winter: Dec 16 - Mar 15

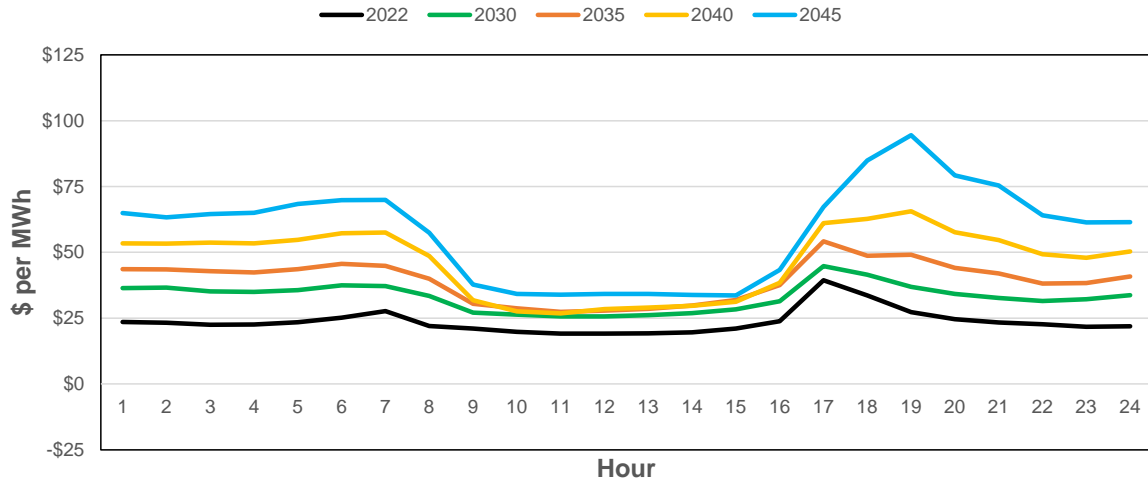

Spring: Mar 16 - Jun 15

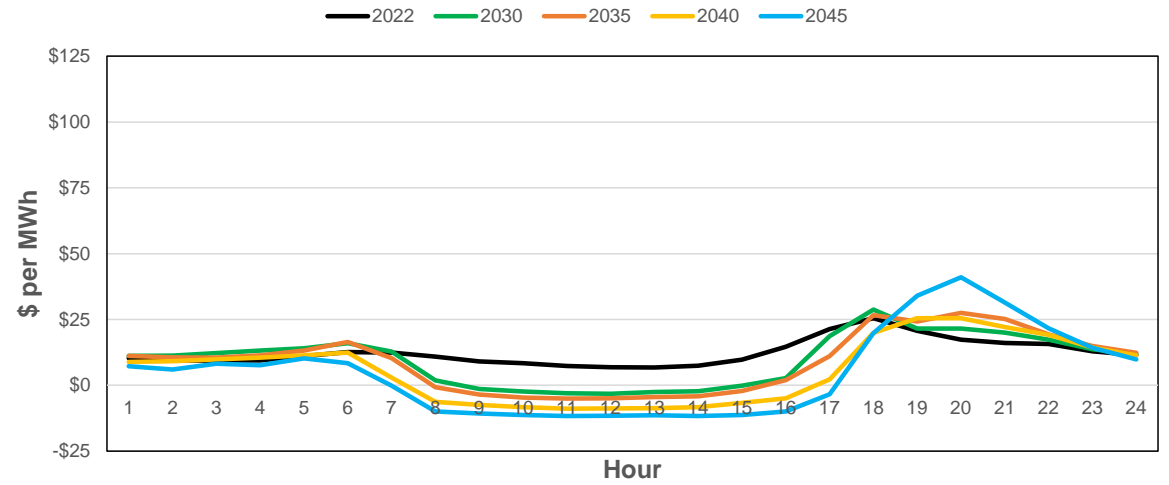

Summer: Jun 16 - Sep 15

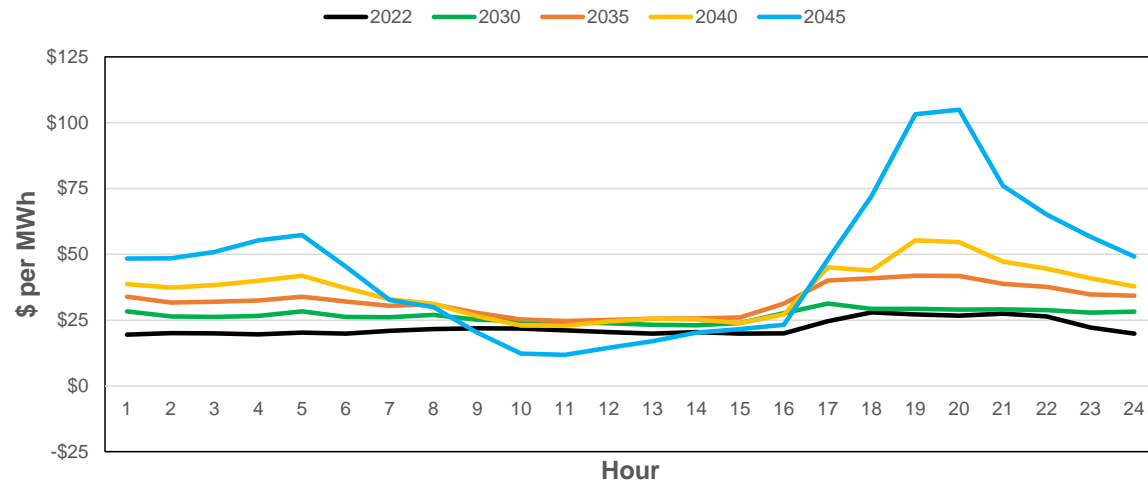

Fall: Sep 16 - Dec 15

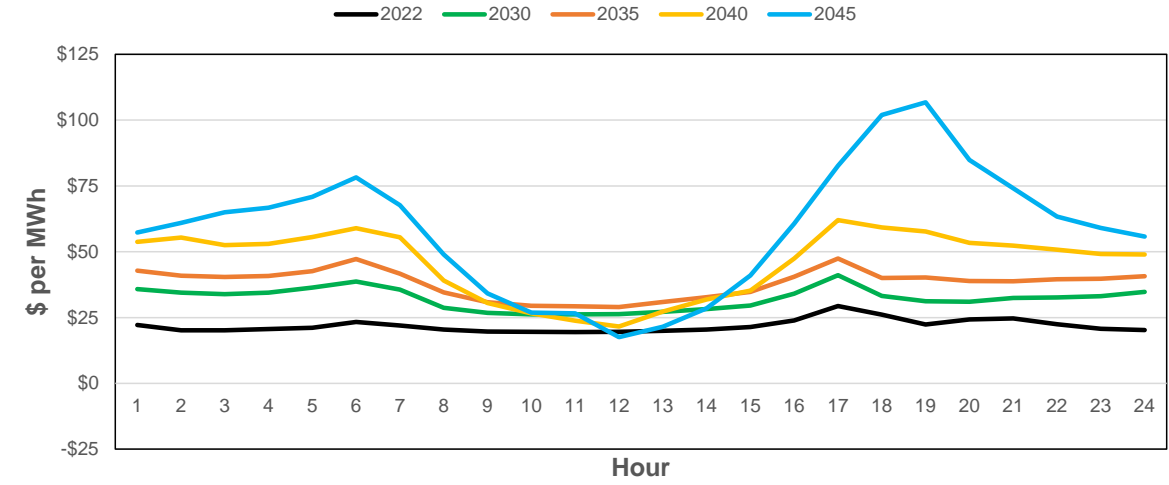

# Greenhouse Gas Forecast U.S. Western Interconnect

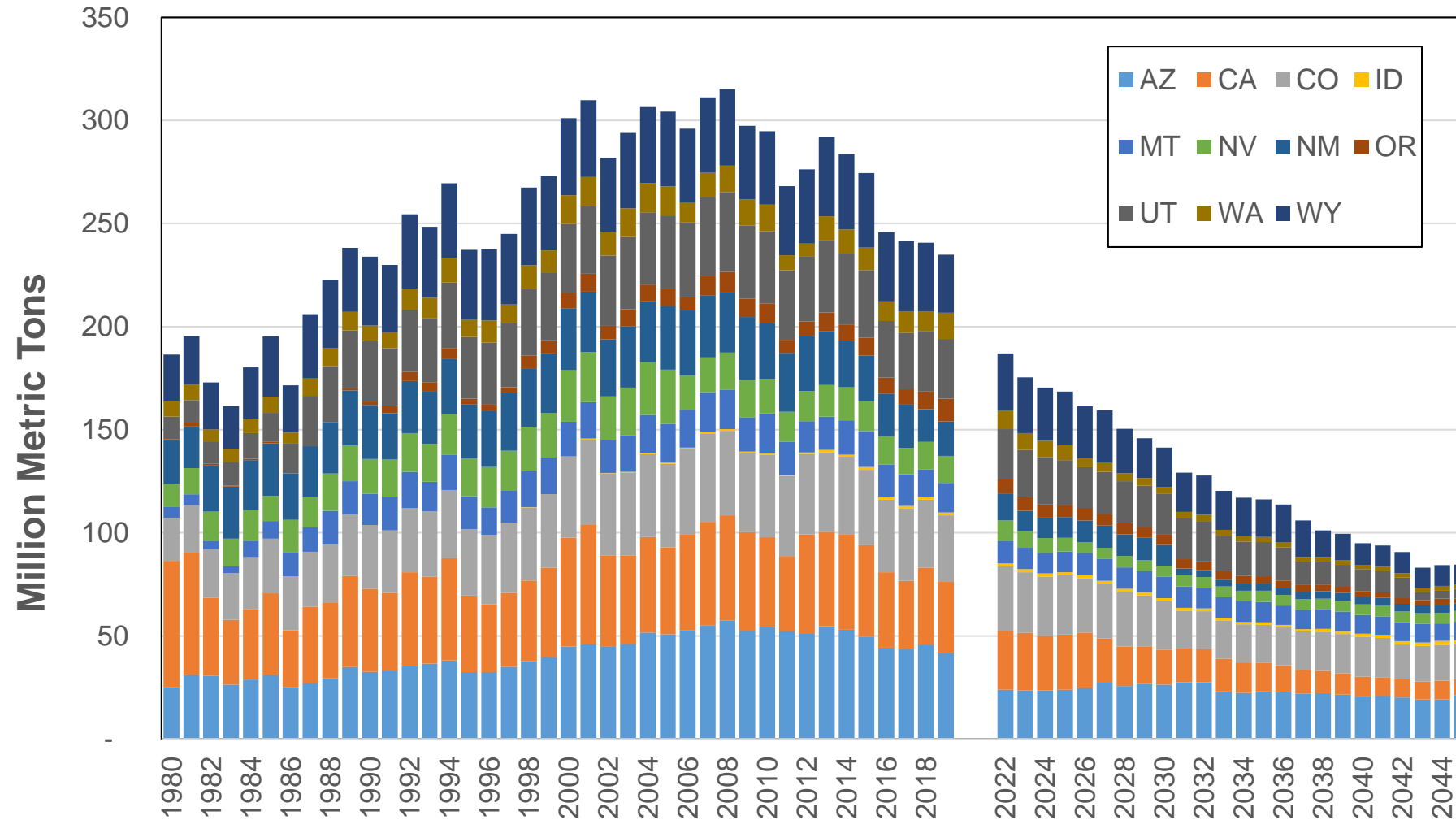

2021 Electric IRP Appendices

# Greenhouse Gas Forecast Northwest States

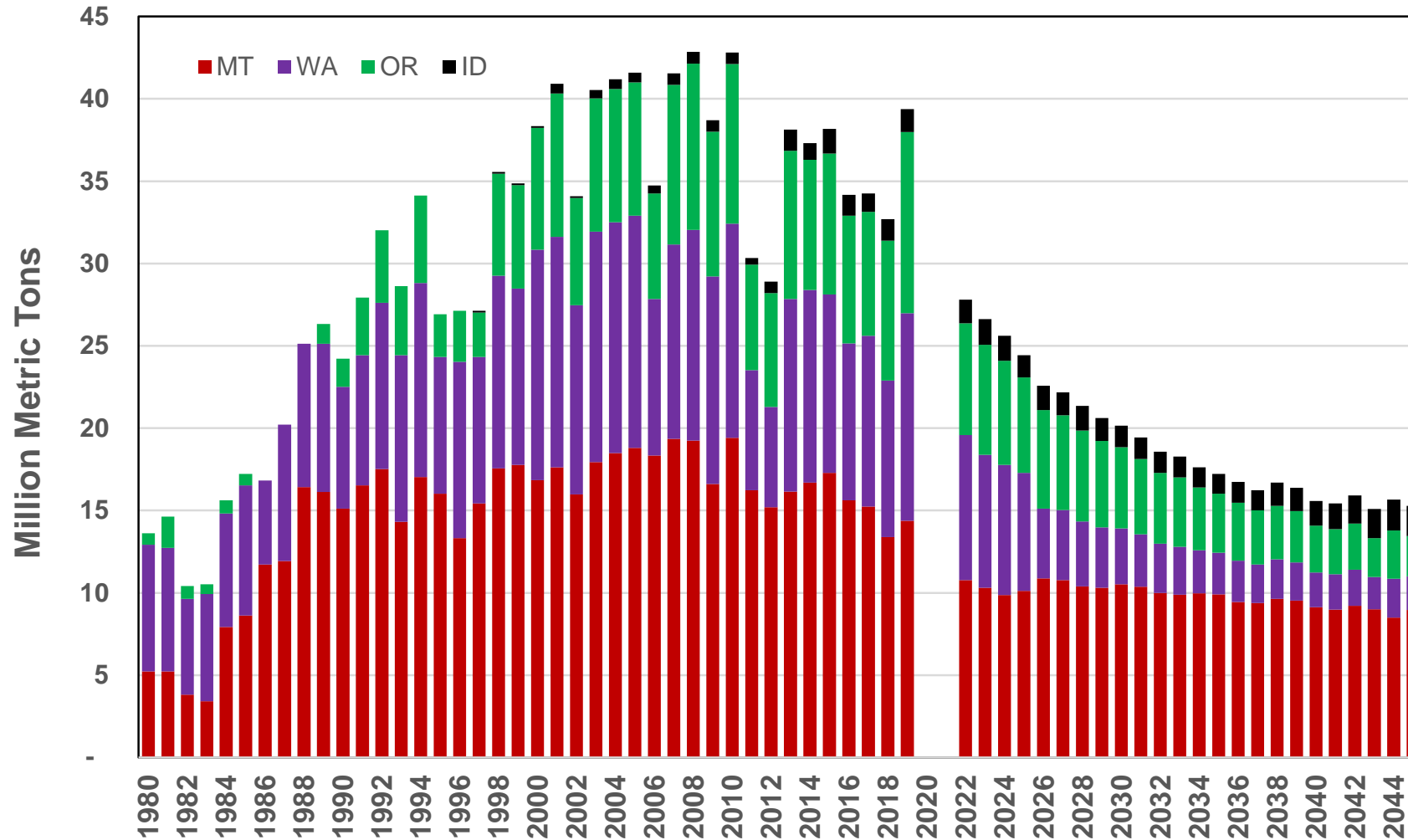

# Market Scenario Assumptions

- **High Natural Gas Prices**

- 90<sup>th</sup> percentile of stochastic prices using 1,000 draws

- **Low Natural Gas Prices**

- 25<sup>th</sup> percentile of stochastic prices using 1,000 draws

- **Social Cost of Carbon “Tax”**

- Western Interconnect Carbon “Tax” on Generation
- SCC pricing beginning in 2025, trending up beginning in 2022.

- **Climate Shift**

- Uses NWCC three climate futures
- Trend Northwest hydro and loads for warming temperatures
- Lower NG CT capability due to temperature change

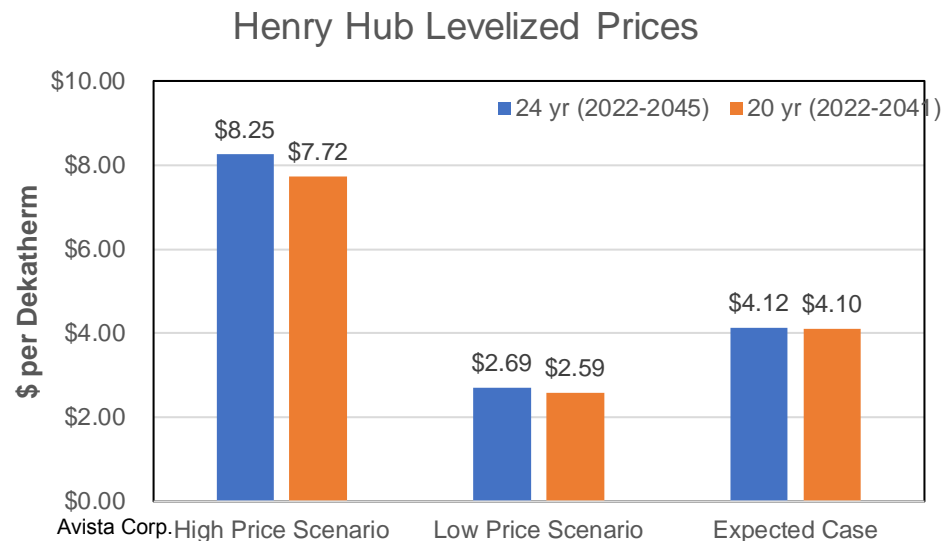

# Climate Shift Methodology (Loads)

- Uses 2024 operating year forecast.
- Overlays the 2020 to 2049 temperature forecast using an average of three climate models chosen by the NPCC.
- Create a linear trend of load based on changes in weather\*- referred to as scalars.
- Apply scalars to expected case load forecast.

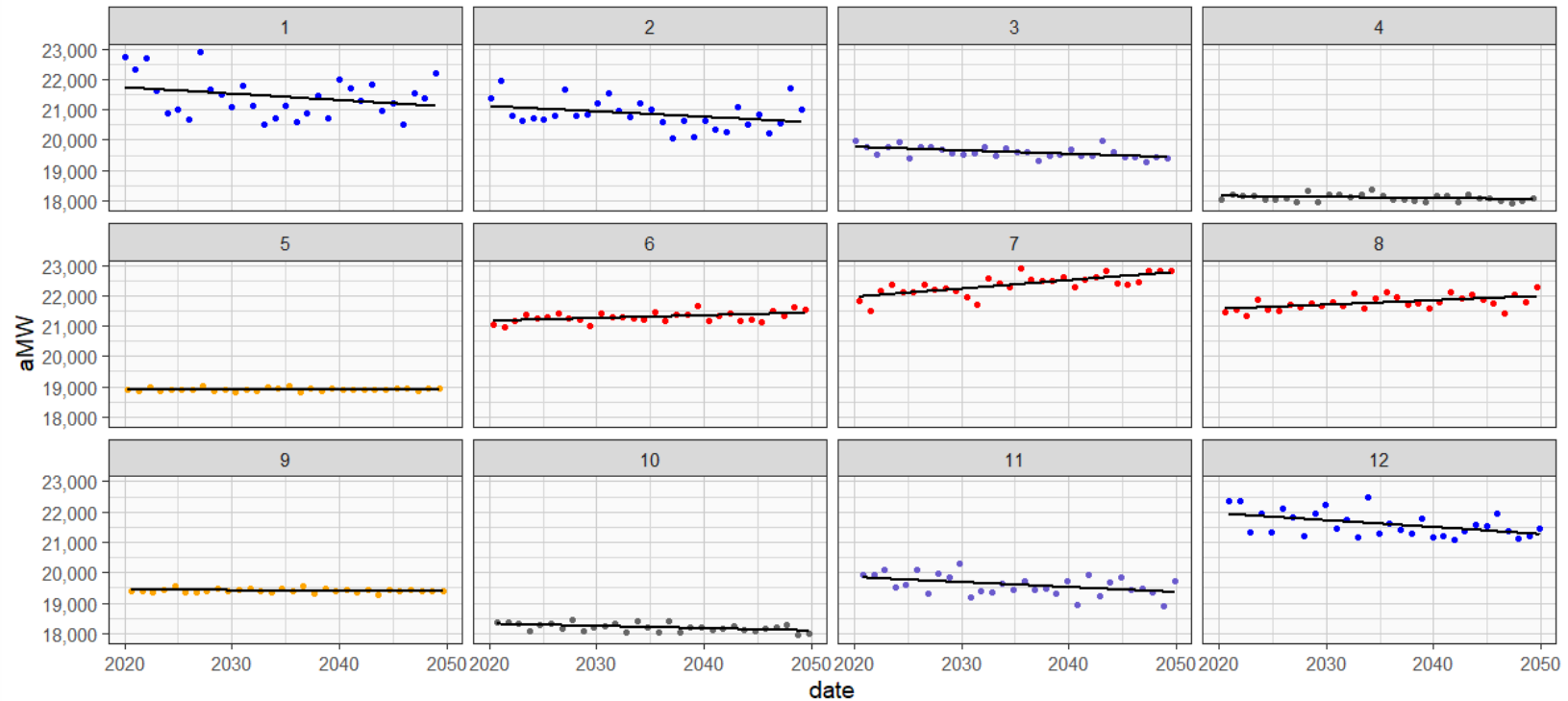

Data & scalars provided by PNUCC

# Climate Shift Methodology (Hydro)

- NPCC provides 80-year hydro history and three models with 30 years of potential hydro for the 2040's.
- Compare the average of three climate models to the 80-year hydro history.
- Linearly trend the change between the beginning and the end of the forecast.

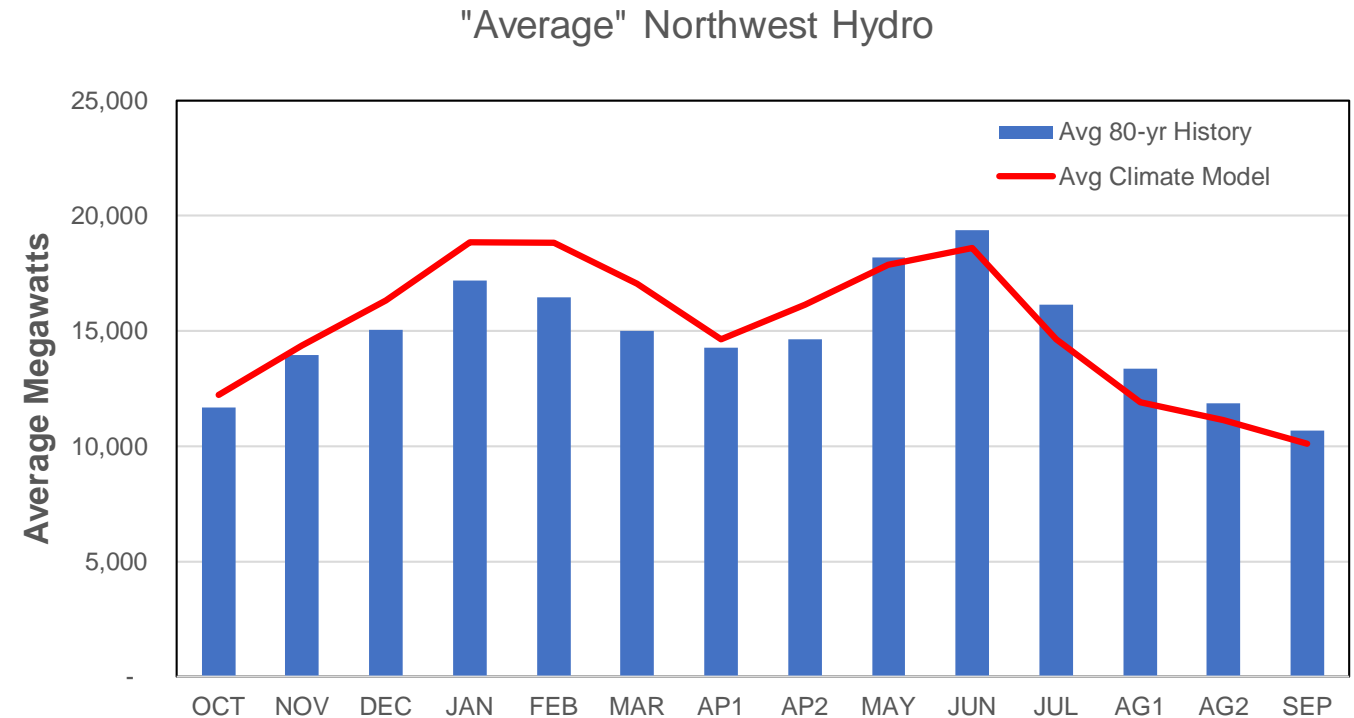

# Scenario Results: Wholesale Electric Prices

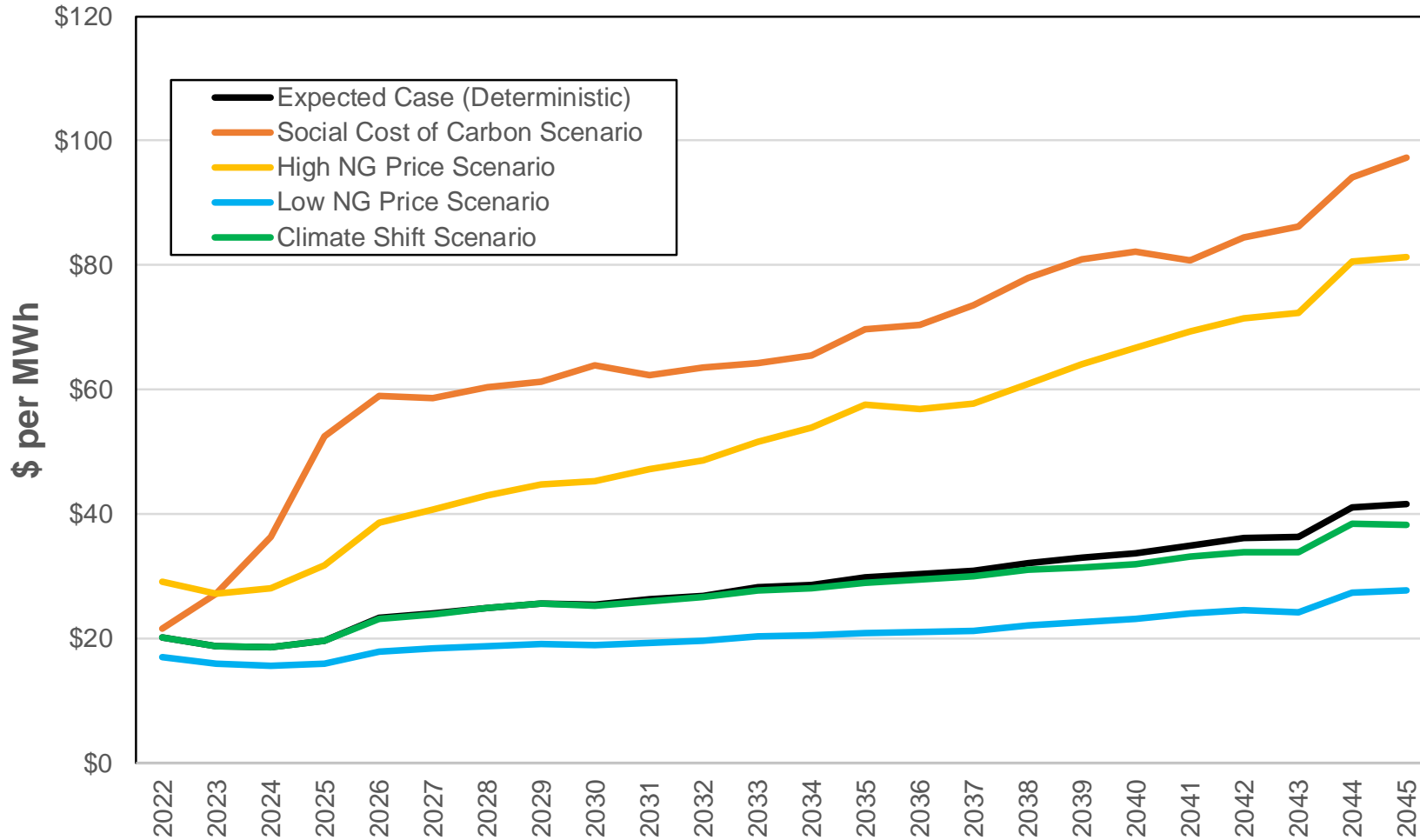

## Levelized Prices (2022-2045)

- Expected Case: \$26.05/MWh
- Social Cost of Carbon: \$58.56/MWh
- High NG Prices: \$46.07/MWh
- Low NG Prices: \$19.35/MWh
- Climate Shift: \$25.51/MWh



# Scenario Results: US Western Interconnect GHG Emissions

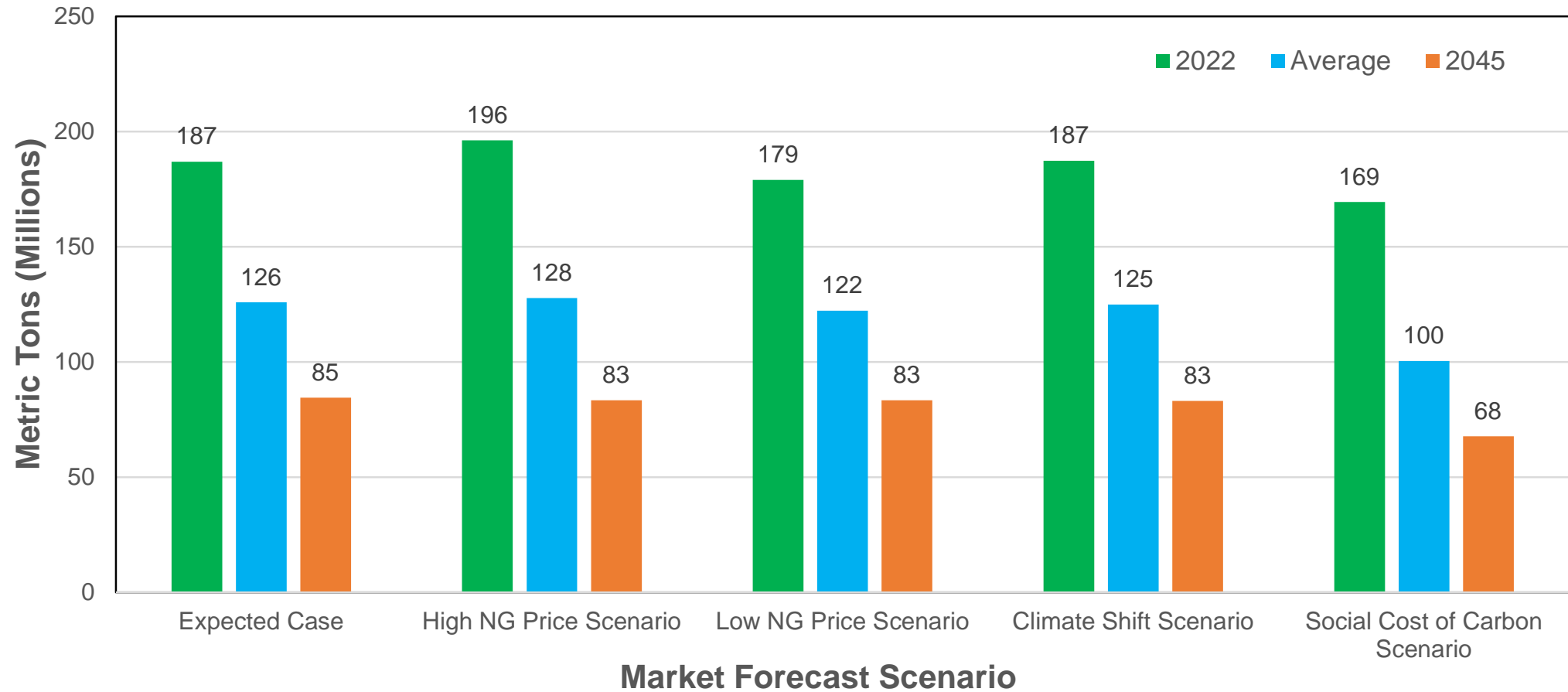

# Scenario Results: U.S. Western Interconnect Resource Type

Year: 2022

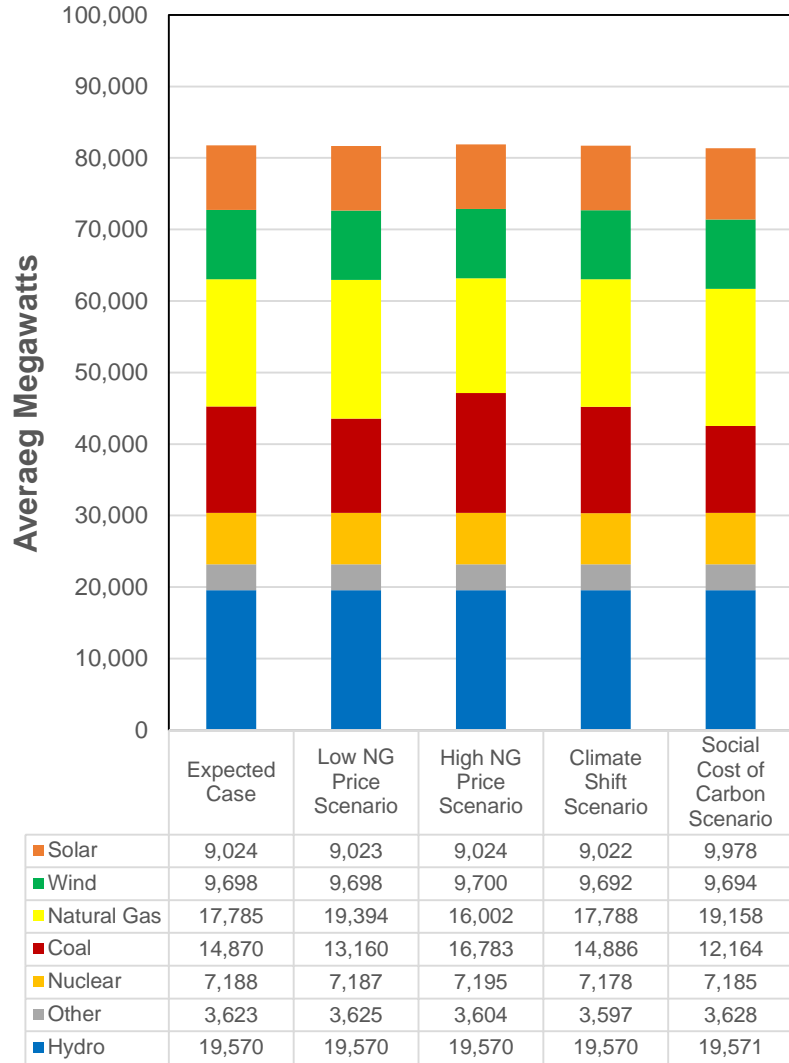

Year: 2030

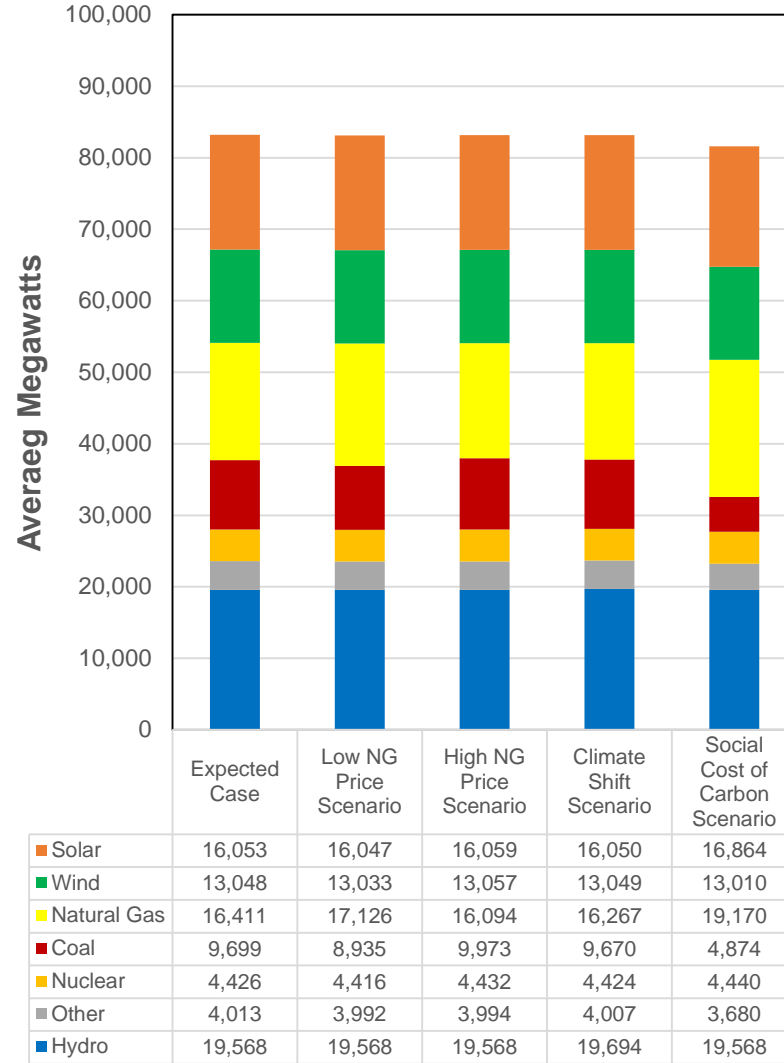

Year: 2040

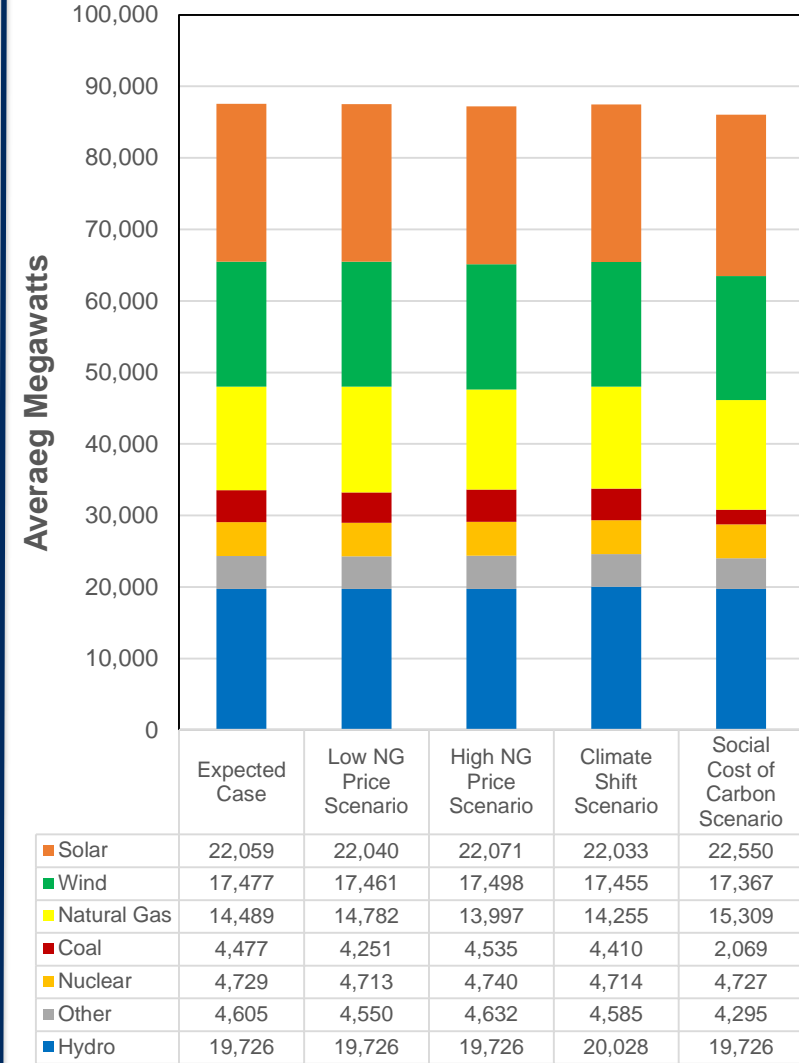

# Incremental GHG Emissions for Energy Efficiency

- This IRP assumes GHG emissions from load reduction and associated emissions from market purchases/(sales)\*
- 2020 IRP assumes average emissions each year based on average emissions compared to load each year. (See blue bars)
- Avista believes average emissions best represents the associated emissions for market purchases/sales:
  - Should this be based on load or generation?
- Avista is considering using incremental emissions for valuing energy efficiency for Washington's cost analysis:
  - Load or generation calculation method?
  - Increase load vs. decrease load method (or average)?
  - At what granularity to apply benefit?

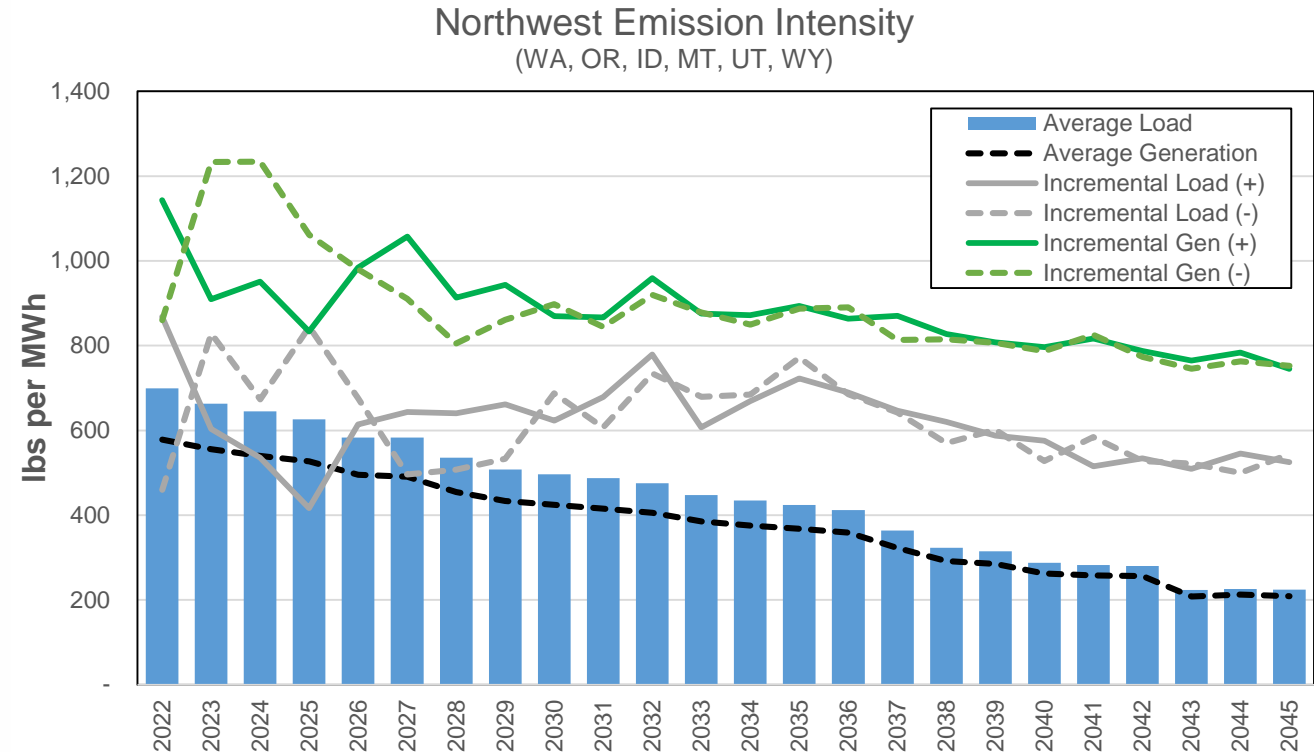

# Data Availability

## Outputs

- Expected Case: annual Mid-C prices by iteration (stochastic)
- Expected Case: hourly Mid-C prices (deterministic)
- Scenarios: monthly Mid-C electric prices
- Regional resource dispatch
- Regional GHG emissions
- Avista resource dispatch data will be included within PRiSM Model

## Inputs (Not already Posted)

- Climate shift scaling factors for load/hydro
- High/low natural gas prices



# 2020 Electric Integrated Resource Plan Draft Portfolio Scenario Analysis

John Lyons, Ph.D.  
Third Technical Advisory Committee Meeting  
September 29, 2020

# Portfolio Scenarios – 2020 IRP

1. Preferred Resource Strategy
  2. Least Cost Plan- w/o CETA
  3. Clean Resource Plan: 100% net clean by 2027
  4. Rely on energy markets only (no capacity or renewable additions) w/o CETA
  5. 100% net clean by 2027, and no CTs by 2045
  6. Least Cost Plan w/o pumped storage or Long Lake as options
  7. Colstrip extended to 2035 w/o CETA
  8. Colstrip extended to 2035 w/ CETA
  9. Least Cost Plan w/ higher pumped storage cost
  10. Least Cost w/ federal tax credits extended
  11. Clean Resource Plan w/ federal tax credits extended
  12. Least Cost Plan w/ low load growth (flat loads- low economic/population growth)
  13. Least Cost Plan w/ high load growth (high economic/population growth)
  14. Least Cost Plan w/ Lancaster PPA extended five years (*financials will not be public*)
- Others: Efficient frontier portfolio (least risk, 75/25, 50/50, and 25/75)

# Portfolio Scenarios- 2021 IRP

1. Preferred Resource Strategy
2. Baseline Portfolio 1 (No CETA renewable targets)
3. Baseline Portfolio 2 (No CETA renewable targets/SCC)
4. Clean Resource Plan (100% Portfolio net clean by 2027)
5. Clean Resource Plan (100% Portfolio clean by 2045)
6. Social Cost of Carbon applied to Idaho
7. Least Cost Plan- w/ low load growth
8. Least Cost Plan- w/ high load growth
9. Least Cost Plan- w/ Northwest Resource Adequacy Market Peak Credits
10. Heating Electrification Scenario 1
11. Heating Electrification Scenario 2
12. Heating Electrification Scenario 3
13. Least Cost Plan- w/ climate shift
14. Least Cost Plan- w/ 2x SCC prices
15. Colstrip serves Idaho customers through 2025
16. Colstrip serves Idaho customers through 2035
17. Colstrip serves Idaho customers through 2045
18. If necessary: CETA deliver to customers each hour
19. If necessary: other resource specific scenarios depending on outcome of PRS results

### **TAC Meeting 3 Notes – September 29, 2020**

**Virtual Attendees:** Shay Bauman, Shawn Bonfield, Annette Brandon, Terrence Browne, Morgan Brummund, Michael Brutocao, Ethan Case, John Chatburn, Corey Dahl (Public Counsel), Michael Eldred (IPUC), Chip Estes, Ben Fadie, Rachelle Farnsworth (IPUC), Ryan Finesilver, Damon Fisher, James Gall, Amanda Ghering, GS, Guest (5), Leona Haley, Lori Hermanson, Jan Himebaugh (BIAW), Elizabeth Hossner, Tina Jayaweera, Clint Kalich, Kathlyn Kinney, Dean Kinzer, Melissa Kuo, Scott Kinney, John Lyons, Fred Heutte (NVEC), Jaime Majure, Kelly Marrin, Stuart M., Eli Morris, Katie Pegan, Tom Pardee, Jorgen Rasmussen, Jeff Schlect, Jennifer Snyder (WUTC), Darrell Soyars, Collins Sprague, Dean Spratt, State of Idaho, Jason Thackston, Unavailable (1), Ken Walter (AEG), Tom Williams, Katie Ware, and Yao Yin (IPUC).

Notes in *italics* after questions were made by the presenter.

### **IRP Transmission Planning Studies – Dean Spratt, Avista**

**Yao Yin (Slide 15):** When Avista contracts with a QF [qualifying facility under PURPA], does the QF contract for transmission at the same time? *Probably a better merchant question. It was studied by us and neighboring utilities. They typically don't have tools to conduct full qualified studies. Does that help?* Yes, thank you.

**Dean Spratt:** Regarding QF versus non-QF impacts, these are studied by us [Avista transmission] and others. The scope is different for these.

**Yao Yin (Slide 16):** Does a QF get into the same queue regarding scope of the project?

**Dean Spratt:** Yes. Anyone, QF or not, that wants to get on the system has to go through the [same] interconnection process. A QF or large project has to go through the interconnection request. There is one queue that captures everything. Transmission planning only sees the larger projects. It could be a cut-off for smaller projects. There are different rules for different states.

**Jeff Schlect:** I'm going to chime in here. I'm the Senior Manager of Transmission Services here at Avista. Yes, all projects work through the same queue under FERC or by state agreement based on the size of the project. There is one queue for all sizes, but they could be subject to a FERC process or to some other process.

**Yao Yin:** Thanks Jeff. I was unsure of the small project cut off.

### **Distribution Planning within the IRP – Damon Fisher, Avista**

**Jennifer Snyder:** HB 1126 has been codified in RCW 19.280.100.

**Rachelle Farnsworth:** Talk about how and if the company is looking at smart inverters and how you will use those?



**Damon Fisher:** Latest IEEE. Yes, but how planning is going to integrate remains to be seen. I don't think the hardware has caught up with the standard yet, maybe by 2021 or 2022. We are not quite there. We would implement that as stated in the new 1547 right through. There are concerns with transmission faults in Germany and California where a lot of load was dropped due to the large amount of inverters and them not recognizing it was a short trip and needed to stay online longer. A distribution fault drops all generation and transmission fault stays online longer.

**Rachelle Farnsworth:** Yes, I was just curious on smart inverter policy and settings. Where is the company on developing a policy on this?

**Damon Fisher:** Existing 1547 is what we are following. New 1547 is the ride through ability. Thank you. That is system protection and I'm not an expert on it.

**Kathlyn Kinney:** Is there something outward facing where you publicize where grid issues are and where DR is needed?

**Jennifer Snyder:** Do you have studies on where DR would be helpful?

**Damon Fisher:** No, there isn't yet. We've been working hard to get modeling for facilities hosting capacity for load and later generation. There are lots of benefits internally for guiding new load to where it doesn't create system constraints. Lots of work is being done on these maps with this intent. Can approach more sophisticated customers first with incentives to help with grid constraints. Some of these studies are out there, such as the work done in New York. I will send a link. If anyone is interested, New York has one that is pretty interesting. New York was able to work through it. There are a few studies out there.

**Damon Fisher (Slide 14):** 15 days in December, it's dark before 4 pm back in the old days when we went to work. Something that would give me pause would be to just use solar to fix a grid issue when there are situations like that.

**Damon Fisher (Slide 15):** Will drastic changes in the day cause a problem as a grid fix issue? Need data and studies. What if we fix the curve with a battery or use two DERs? Maybe we just go straight to a battery. All of these are considerations in fixing the grid and adding resources when available to the system.

**Damon Fisher (Slide 17):** Blue is transmission. Orange is the 230 kV lines. BPA is in there as well. Airway Heights is a big growth area. We don't serve the new Amazon facility directly, but local growth in the area is occurring through our substation feeders nearby and they are approaching their limits.

**Yao Yin (slide 19):** I'm not very familiar with the concept of hosting capacity. What does that mean?

**Damon Fisher:** Our system can host your generation. Like 5 MW of solar. We can do pre-analysis of the system with gobs and gobs of analysis to show constraints on a map. If it's in a development and you want to put in 1 MW of solar, where can I get it

attached quicker? I can also do that for load. Pre-analysis of where you can add more resources without causing system problems. Load is also interesting. Generators who might be interested in hosting solar or whatever generation on our system. You run through scenarios of attached generation and look for constraints such as high voltage problems. Map can then be geo-referenced that tells generators of where you can locate projects. Possibly to do pre-analysis to shorten Dean's queuing process. Intend to do this with load and generation and where to locate generation without causing problems.

**Yao Yin:** Does that consider upgrades only for existing or does it assume upgrades happen?

**Damon Fisher:** Yes. Run analysis until you encounter the first constraint. If done correctly, you can do a hosting map that will guide these projects without requiring system investment. Hosting capacity map will go stale when resources are added. Easy to go stale if maps aren't maintained. How often do you do this? It could be a resource intense operation. Possibly automate it, but that remains to be seen.

**Damon Fisher (Slide 19):** AMI data is 5 minutes out of the meters. Can apply various techniques to the data to pick out what load is occurring. Where are we getting electric vehicles as more of them are out there? Will we have less visibility of where they are and what they are doing to the system as they are charging? Can look for the most offensive user of energy or demand (AC) and then target those as a DER candidate. This causes all sorts of weird questions on tariffs, targeting, etc. For northwest utility DERS, this is an enlightening conversation with everyone. What is right, appropriate, average and above average?

### **Demand Response Potential Assessment – Kelly Marrin, AEG**

**Kelly Marrin:** This Demand Response (DR) Potential Assessment shows the preliminary results. It is not the first round, but is not finished yet.

**Brian Fadie (Slide 11):** The first note under sources mentions an Avista proposed cycling strategy for DLC Central AC and Smart Thermostats (cooling). Can you describe that further?

**Kelly Marrin:** The Power Plan has something closer to 1, when talking to Avista about what they might use, they said they'd implement something more moderate so AEG adjusted this down.

**Kathlyn Kinney:** On the percentage with EV charging, what is getting measured? Is it a percentage over the top and will this be changing over the year, what exactly is being measured here?

**Kelly Marrin:** This is an average per customer reduction per event and accounts for all participants whether they're plugged in or charging. As EV penetration increases, megawatts will go up and that'll show up in EV saturation. Impacts start low, but by 2045 they will be substantial as we have more EVs.

**Yao Yin:** Any assumptions regarding battery duration and efficiency?

**Kelly Marrin:** We will provide more detail on technical research done on batteries. We have six hours storage assumed per day and 8 hours for larger batteries.

**Tina Jayaweera:** There a number of electrification scenarios in the IRP, have you incorporated that in your work?

**Kelly Marin:** We are not doing any scenarios. We are using the same forecast.

**James Gall:** From energy efficiency, those electrification scenarios already include them. We have not discussed DR yet, but will discuss this when our studies are complete. Tina thanks for reminding us to circle back and do that analysis.

**Yao Yin:** Big picture, if a technology is used for ancillary services does it hurt the chance for it to serve other purposes? For example, a battery. Are these two mutually exclusive?

**Kelly Marrin:** That's right. Ancillary service doesn't always have a specific time, so we don't add these and don't stack the value of ancillary services on top of the capacity. If there's an overlapping event. Ancillary services are not at a specific time, they can be at any time of the year or day. We never add these to the other programs. This loads first. Capacity is looked at separately and in a particular order. They account for not calling the same load at the same time but for ancillary service. It's a completely different load and we assume this doesn't happen during system peak event times.

**Yao Yin:** So there is an order?

**Kelly Marrin:** Yes, could do either one, but not both.

**Damon Fisher:** Have any of the grid limitations been taken into consideration? All batteries operating on a feeder at the same time that cause voltage whip-sawing if they are on all at once?

**Kelly Marrin:** We haven't gone into that level of detail. This is a broad brush study, less broad than before, but take it with the idea of trying to get a sense of what the potential could be. But we haven't looked at it at the technical level of response.

**Damon Fisher:** The feeder itself could be at the limit itself, not the technical potential.

**Kathlyn Kinney:** At a high level, how does this compare to increasing electricity demand over time? How close are we to breaking even?

**Kelly Marrin:** Haven't gotten to that step yet. If we add up all of the DR reductions versus the forecast. We haven't gotten to that step yet, but when we add up at a very high level of the percentage – I think close to 10%, but 5 – 10% of total peak demand by 2045.

**Kathlyn Kinney:** Do we know what the increase from electrification will be?

**James Gall:** It's available on the website, but is about 800 MW over the next 24 years. If we did all these programs, we can offset more than our load growth. DR is only for those couple of hours. We still have the rest of the year to deal with.

**Fred Heutte:** I just came in from another call I had to run to. DR is a key interest these days. Specifically, we think the new standard grid-integrated water heaters will provide a lot of savings. We are very interested in utilities trying to show this. How many electric water heaters are now in the Avista service territory? We've seen increasing periods of very high pricing at Mid-C and elsewhere. Will that be folded into the value of DR?

**Ken Walter:** The water heater number is not in front of me, but we could map it.

**Fred Heutte:** 45-55% in the region. It is helpful to know. I've looked at the saturation assessments, but don't know for sure. My guess over time is a high number above 50%.

**James Gall:** That is the plan. We'll assign a price to call on DR. From a modeling perspective, it's difficult, it will need to be done outside of the model. Not sure of the price yet, so there is a market opportunity to take advantage of. It is not impossible to model, but very difficult.

**Fred Heutte:** Lots of different factors with coal retirements and limited DR now.

**Tina Jayaweera:** For the transmission and distribution side, how can DR help with this and what we heard earlier? Haven't finished with costs for both T&D particulars.

**Kelly Marrin:** A question we need to address together when we get there. Sounds like there could be additional value from geographic-specific DR. Definitely on the location specific side. Will make a note of that for when we get there and will revisit with Avista when we get there.

## **Conservation Potential Assessment – Ken Walter, AEG**

**Tina Jayaweera:** Is the T&D deferral being incorporated here?

**Ken Walter:** It's being incorporated in the avoided cost. I'll ask Ryan if he remembers. It's not an exact value. We are looking into how to have a more prospective approach to historic value of the net plant value for T&D deferral.

**Tina Jayaweera:** The Council has a proposed methodology, I can't remember if Avista used that?

**Ryan Finesilver:** No, it wasn't used but we'd be happy to talk about it.

**Tina Jayaweera:** Ok, we can talk about it offline.

**Brian Fadie:** Is the social cost of carbon being considered in these cost effectiveness tests?

**James Gall:** Yes, we include it for incremental energy efficiency. There will be more emissions avoided somewhere else in the region. There is a slide on that later today. More energy efficiency and more incremental emissions are avoided and we would include that benefit.

**Yao Yin (Slide 14):** In the load and resource balance, which line is used to determine the amount of energy efficiency?

**Ken Walter:** The middle green line, but we provide savings at the measure level. About 7,000 line items.

**James Gall:** The load forecast which we show there is reduced somewhere between the red and the hashed lines. Energy efficiency programs that are cost-effective will reduce that load.

**Grant Forsyth:** Forecast without energy efficiency included, run PRiSM, and then I gross up the forecast for energy efficiency that could be existing in the future.

**James Gall:** Yes, it's a circular chicken and egg issue as we don't know what programs will be used in the future. The idea is to get a forecast of programs that are cost effective to increase or decrease loads, then iterate between the two. Start with a high load forecast, select energy efficiency programs with PRiSM, and then redo the forecast with and without energy efficiency for energy and for peak load.

**Yao Yin:** In Grant's forecast without energy efficiency, PRiSM is then used to select and adjust that load. How does this slide fit into that process (slide 14)?

**James Gall:** There are a number of programs that are available to be selected as to whether they should move forward or not.

**Ken Walter:** Pool of all measures is what the model selects from.

**Richard Keller:** Is slide 14 in GWh, not aMW? Yes, GWh. Thanks.

**Tina Jayaweera:** Catching up with industrial customers in your assessment, are those two large industrial customers eligible for energy efficiency programs?

**Ryan Finesilver:** I believe all customers are eligible. All customers pay into the efficiency program. So I guess the question is how we are accounting for industrial customers in the IRP? They are not in the baseline. The problem is we can't apply a curve to a single individual customer. The large industrial company makes its own energy efficiency decisions, which is not something we can do on a model level.

**James Gall:** We need to take this issue back as a group internally and discuss it.

**Tina Jayaweera (slide 15):** How are you accounting for the missed energy efficiency for these two customers?

**Ryan Finesilver:** Assume that their efficiency will be included as well.

**Ken Walter:** Not in baseline so not included. Can't apply a curve designed for a whole population to a single individuals. Other clients have approached this by having AEG speak to these customers and see what they intend to do.

**James Gall:** Sounds like we need to discuss this internally.

**Ken Walter:** Tina, thanks for the idea.

**Tina Jayaweera:** How are you determining the peak impact for energy efficiency? What is the methodology?

**Ken Walter:** The ratio of peak kW to annual kWh based on end use shapes on an hourly level. We use that to segment.

**Tina Jayaweera:** For load shapes, what are your main sources?

**Ken Walter:** Open EI and I think the Yakima weather station.

**Yao Yin:** When are the peak hours for Avista for both winter and summer?

**James Gall:** 7-8 am in morning or 5-6 pm in the evening for the winter. Summer peaks around 4 pm or 6 to 7pm. summer peak usually occurs in July or August and winter is in the end of November through mid-February. The days of the week also matter, Monday through Wednesday are usually the highest load. Some peak weather events occur on holidays or weekends when loads are lower.

**Yao Yin:** What is the method used to determine peak hours?

**James Gall:** Looking at actual load history.

**Tina Jayaweera:** For energy efficiency do you take the average or the peak?

**Ken Walter:** We do it based on the actual single peak hour.

**Yao Yin:** I'm a little confused, is it the single peak hour, not a period but one hour?

**James Gall:** Yes, we assume it as a single hour as opposed to an average over 2 to 3 hours.

**Yao Yin:** How did you determine which hour?

**James Gall:** For each month, Grant looks at the hottest and coldest day of the month and averages the historic weather years to come up with a peak hour.

**Yao Yin:** That results in one single peak hour instead of the timeframes you mentioned earlier?

**James Gall:** Our modeling is at the annual peak perspective. We are not looking at when that specific hour is. We are given a high water mark and then looking at measures to reduce it from there. Value we are looking at is an average. The future is an expectation of what that will change to.

**Tina Jayaweera:** The IRP is an hourly model. Are you taking 8760 hours from energy efficiency? The peak from here doesn't actually get used. Is that correct?

**James Gall:** The 8760 is used for the economic analysis of energy valuation for how much energy is worth. We get a summer and a winter peak value. Evaluate on energy and then how much it lowers winter or summer peak value for the L&R.

**Tina Jayaweera:** Confused about peak of a couple of hours versus what we have here.

**James Gall:** We don't know a specific hour when it will occur.

**Tina Jayaweera:** That makes sense and it can shift around. My concern is on the energy efficiency side, it's over or under estimating because it's not just one hour.

**Ken Walter:** How a peak event breaks down across end use typically won't be materially different so there is not much risk of over or under estimating.

**Tina Jayaweera:** My concern is with winter, if it occurs in the morning versus the evening, equipment operates differently. I don't know how impactful this would be, just exploring.

**Ken Walter:** I'm making a note on that.

**James Gall:** No model can evaluate every hour so that the model can solve. We don't know the specific hour when a peak will occur. It is not a consistent hour for every day. All inputs are available on our website in the same format I used in the IRP.

### **Electric Market Price Forecast, James Gall**

**Richard Keller (slide 4):** Is this the average annual price?

**James Gall:** Yes, for on peak and off peak.

**Richard Keller:** How does the model look at hourly reliability attributed to operating reserves?

**James Gall (slide 12):** The model is solving for operating reserves on a system basis for an area or zone and not on a utility basis. Six percent operating/spinning and non-spinning reserves and 2% for regulation. Hopefully, that helps.

**Fred Heutte:** A lot of data there. I'm not terribly surprised with trying to take into account all of the things in the stochastic model. There is a jump logic approach to shock parameters, I'm wondering if you do something like that to pick up a COVID or such an event. PAC does something similar.

**James Gall:** Not specifically, but there are specific tail shock events that do occur. A black swan event is great to test as a scenario. They show up, but not at the same time. Stochastic modeling tries to take into account an event like those tail events.

**Yao Yin (slide 12):** Is there an algorithm that calculates whether the wind/solar can be integrated?

**James Gall:** There is not a specific requirement looking at the instantaneous number. There is not a dynamic reserve held for winter. It holds back capacity for integration based on the inputs. We can model this in the future, but it probably wouldn't solve in time to be useful as it would slow the model to a crawl. The model wouldn't solve in enough time to be usable. Maybe the technology will get better so it could solve.

**Yao Yin:** Is the amount of reserve percentage manually entered?

**James Gall:** Yes, for price, but for reliability it's dynamic at the local system level. We include it for our need at a local system level. In the resource adequacy portion and in PRiSM it is rolled up in the model runs and set aside for capacity from the reliability model.

**Yao Yin:** Is the local dynamic done within PRiSM?

**James Gall:** No, in the reliability model which estimates what the planning margin should be and then that number gets put into PRiSM. We will talk about that in the next meeting.

**Fred Heutte:** The SAAC talked about this in the morning. What is the west going to do for new resources for the late 2020s and early 2030s with the shape of prices? They are seeing a similar issue for the regional modeling.



**James Gall:** Yes, that's the rest of the presentation.

**Charlie Inman (Slide 13):** How many zones are in Avista's [Aurora] model?

**James Gall:** 12 to 14. We are using the same database as the 2020 IRP. There is a newer one, but that one came out too late for this IRP.

**Yao Yin (slide 16):** Is DR considered on the supply side and not as a load adjustment?

**James Gall:** It is a load adjustment, but the model dispatches it so it acts like generation. Included it here because it acts like a generator – same with net metering.

**Yao Yin:** Net metering is a reduction to load and DR is dispatched?

**James Gall:** Correct. Model first goes to DR to select the amount of DR. DR is dispatched by the model, but it may or may not be chosen.

**Yao Yin:** So the amount of DR is from a model result whereas net metering is based on an entered number?

**James Gall:** Correct. Along with combined cycle and simple cycle generation. There is a process to shut off generation – typically renewables have a tax credit and can operate with a negative price. Hydro has a negative \$25 price but it often can't be turned off due to a fish constraint. Negative prices are based on dispatch order.

**Kathlyn Kinney (slide 22):** Is there somewhere where pricing here transfers to price reductions and scenarios where higher priced renewables still fit in and make sense?

**James Gall:** When the model looks at a resource choice it's looking at the margin. It is willing to pay more for the resource that meets those super peak hours. Now you have to pay for solar plus storage and the extra cost may not equal the extra benefit you get from that solar plus storage resource. Start to see what hours to dispatch a DR program and whether they are for economic or for reliability reasons. As far as demand goes, we are starting to see where some of those resources might be dispatched.

**James Gall:** Back to slide 21, the history of electric price forecasts since I've been doing them here since 2005. A few times we got it right and others we were too high. In the teens we were getting lower and now we are pretty close to the market. Prices over the last 15 years have been falling, similar to loads.

**James Gall (slide 24):** In the analysis, we will make a decision about if a plant is uneconomic, such as Colstrip. In Washington, there is a cost cap for new renewables and it is load versus generation based in other states.

**James Gall (slide 25):** The rest of the slides are on scenarios that we agreed to perform previously for this IRP.

**Yao Yin:** Which natural gas forecast will be used for the October 15<sup>th</sup> filing [Idaho avoided cost filing]?

**James Gall:** Will need to check. We used expected price (middle), which is based on the forecast from the consultants we hire rather than a higher or lower gas price

**Yao Yin:** Why don't we include the expected case in here?

**James Gall:** It is, these are higher and lower scenarios for high and low gas prices.

**Jennifer Snyder:** Can you give a high level overview of your social cost of carbon modeling and what's changed?

**James Gall:** The model was used to acquire the resources based on the resource plus cost of the social cost of carbon plus upstream emissions plus construction costs. Energy efficiency used an average rate, we have been talking about using an incremental cost (talked about more this afternoon). Market purchases/sales use an average emission rate as well – this is not a change. Two changes – energy efficiency average to incremental and including a social cost of carbon cost for resource acquisition.

**Corey Dahl:** What is the problem with the social cost of carbon?

**James Gall:** To capture the cost of carbon associated with the manufacturing and construction processes associated with the resources – both sides. We used construction and operations life cycle carbon analysis study from NREL. It is a small amount of dollars, but it tries to estimate the total carbon costs associated with different resource choices.

**Kathlyn Kinney (slide 31):** Incremental means?

**James Gall:** To run existing infrastructure, how would the system operate in that world.

**Jennifer Snyder:** I was kicked off the call and just rejoined. I missed what you said and will have to talk with you later.

**James Gall:** That's fine, we can have an offline conversation.



*2021 Electric Integrated Resource Plan*  
**Technical Advisory Committee Meeting No. 4 Agenda**  
 Tuesday, November 17, 2020  
 Virtual Meeting

<b>Topic</b>	<b>Time</b>	<b>Staff</b>
Introductions	9:00	Lyons
Final Resource Needs Assessment	9:15	Lyons
2020 Renewable RFP Update	9:45	Drake
Break	10:20	
Portfolio Modeling Overview	10:30	Gall
Lunch	11:30	
Draft PRS and Scenarios	12:30	Gall
Adjourn	2:00	

.....  
 → [Join Skype Meeting](#)

Trouble Joining? [Try Skype Web App](#)

Join by phone

[509-495-7222](#) (Spokane)

English (United States)

[Find a local number](#)

Conference ID: 67816

[Forgot your dial-in PIN?](#) | [Help](#)

.....



# 2021 Electric IRP TAC Introductions and IRP Process Updates

John Lyons, Ph.D.  
Fourth Technical Advisory Committee Meeting  
November 17, 2020

# Updated TAC Meeting Guidelines

- IRP team working remotely through the rest of this IRP, but still available by email and phone for questions and comments
- Some processes are taking longer remotely
- Virtual IRP meetings until able to hold large group meetings again
- Joint Avista IRP page for gas and electric:  
<https://www.myavista.com/about-us/integrated-resource-planning>
  - TAC presentations
  - Documentation for IRP work
  - Past IRPs

# Virtual TAC Meeting Reminders

- Please mute mics unless speaking or asking a question
- Use the Skype chat box to write questions or comments or let us know you would like to say something
- Respect the pause
- Please try not to speak over the presenter or a speaker who is voicing a question or thought
- Remember to state your name before speaking for the note taker
- This is a public advisory meeting – presentations and comments will be recorded and documented

# Integrated Resource Planning

- Required by Idaho and Washington\* every other year
- Guides resource strategy over the next twenty + years
- Current and projected load & resource position
- Resource strategies under different future policies
  - Resource choices
  - Conservation measures and programs
  - Transmission and distribution integration for electric
  - Gas distribution planning
  - Gas and electric market price forecasts
- Scenarios for uncertain future events and issues
- Key dates for modeling and IRP development are available in the Work Plans

# Technical Advisory Committee

- The public process piece of the IRP – input on what to study, how to study, and review of assumptions and results
- Wide range of participants involved in all or parts of the process
  - Ask questions
  - Help with soliciting new members
- Open forum while balancing need to get through all of the topics
- Welcome requests for studies or different assumptions.
  - Time or resources may limit the number or type of studies
  - Earlier study requests allow us to be more accommodating
  - **August 1, 2020** was the electric study request deadline
- Planning teams are available by email or phone for questions or comments between the TAC meetings



# 2021 Electric IRP TAC Schedule

- TAC 1: Thursday, June 18, 2020
- TAC 2: Thursday, August 6, 2020 (Joint with Natural Gas TAC)
- TAC 2.5: Tuesday, August 18, 2020 Economic and Load Forecast
- TAC 3: Tuesday, September 29, 2020
- **TAC 4: Tuesday, November 17, 2020**
- TAC 4.5: December 2020 – 2 Hours on Scenarios
- TAC 5: Thursday, January 21, 2021
- Public Outreach Meeting: February 2021
- TAC agendas, presentations, meeting minutes and IRP files available at:

<https://myavista.com/about-us/integrated-resource-planning>

# Process Updates

## Available IRP Data:

- Avista Resource Emissions Summary
- Load Forecast
- CPA Measures
- Avista 2020 Electric CPA – Summary and IRP Inputs
- Home Electrification Conversions
- Named Populations
- Natural Gas Prices
- Social Cost of Carbon

## Files Added Since TAC 3:

- High and Low Natural Gas Prices
- Market Modeling Results
- Climate Shift Scenario Inputs
- 2021 IRP New Resource Options

# Today's TAC Agenda

- 9:00 Introductions, Lyons
- 9:15 Final Resource Need Assessment, Lyons
- 9:45 2020 Renewable RFP Update, Drake
- 10:20 Break
- 10:30 Portfolio Modeling Overview, Gall
- 11:30 Lunch
- 12:30 Draft PRS and Scenarios, Gall
- 2:00 Adjourn



# 2020 Electric IRP Resource Need Assessment

John Lyons, Ph.D.  
Fourth Technical Advisory Committee Meeting  
November 17, 2020

# Load & Resource Methodology Review

- Sum resource capabilities against loads
- Resource plans are subject to 5% LOLP analysis – determines planning margins
- Colstrip is included through 2025 per 2020 IRP
- Capacity
  - Planning Margin (16% Winter, 7% Summer)
    - Using 2020 IRP result; pending future analysis
  - Operating Reserves and Regulation (~8%)
  - Reduced by planned outages for maintenance
  - Plan to largest deficit months between 1- and 18-hour analyses
- Energy
  - Reduced by planned and forced outages
  - Maximum *potential* thermal generation over the year
  - 80-year hydro average, adjusted down to 10<sup>th</sup> percentile

# One Hour Peak Load & Resource Position

## 1 Hour Peak Load & Resource Position

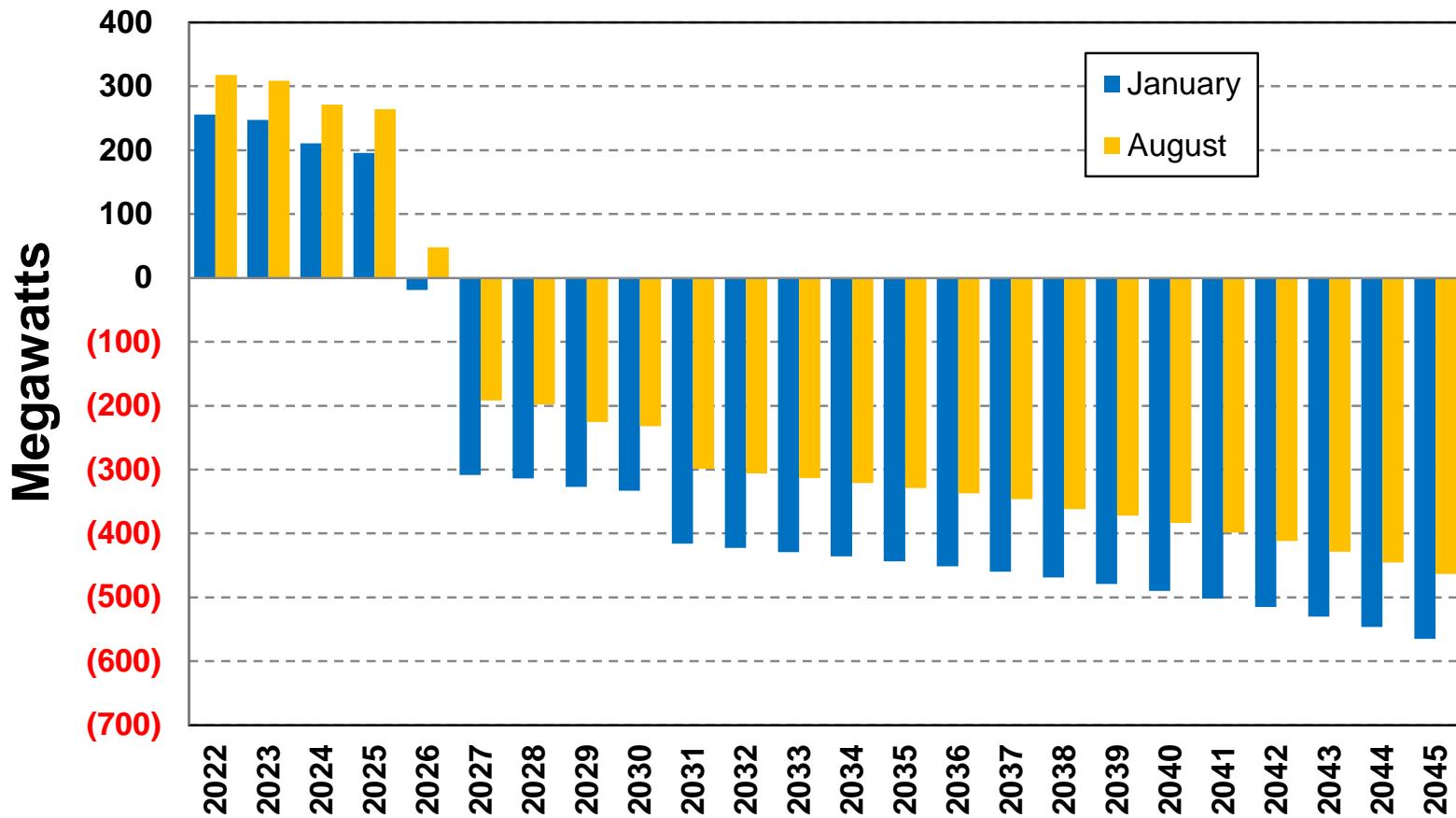

# 18-Hour Peak Load & Resource Position

## 18 Hour Peak Load & Resource Position

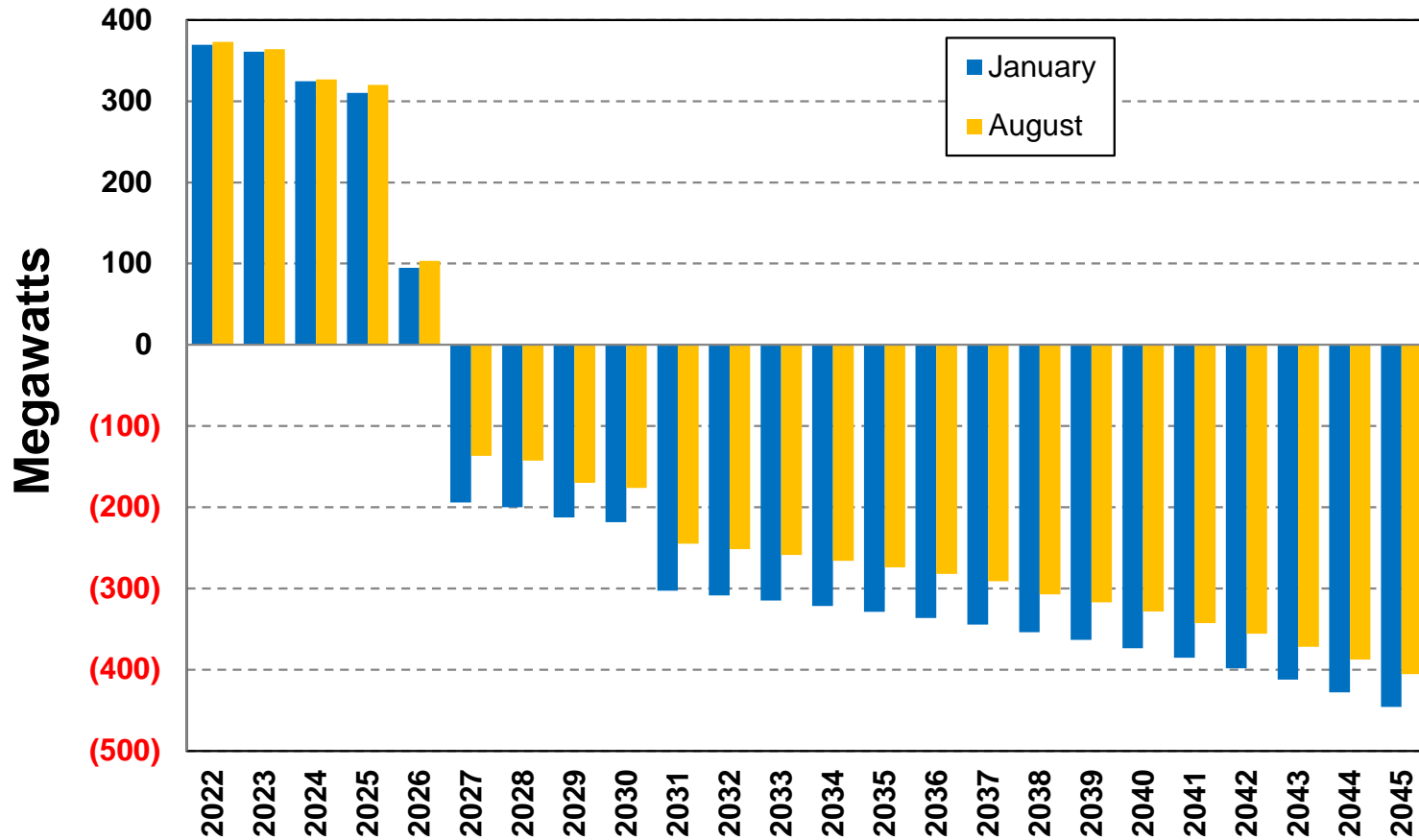

# Energy Load & Resource Position

## Energy Load & Resource Position

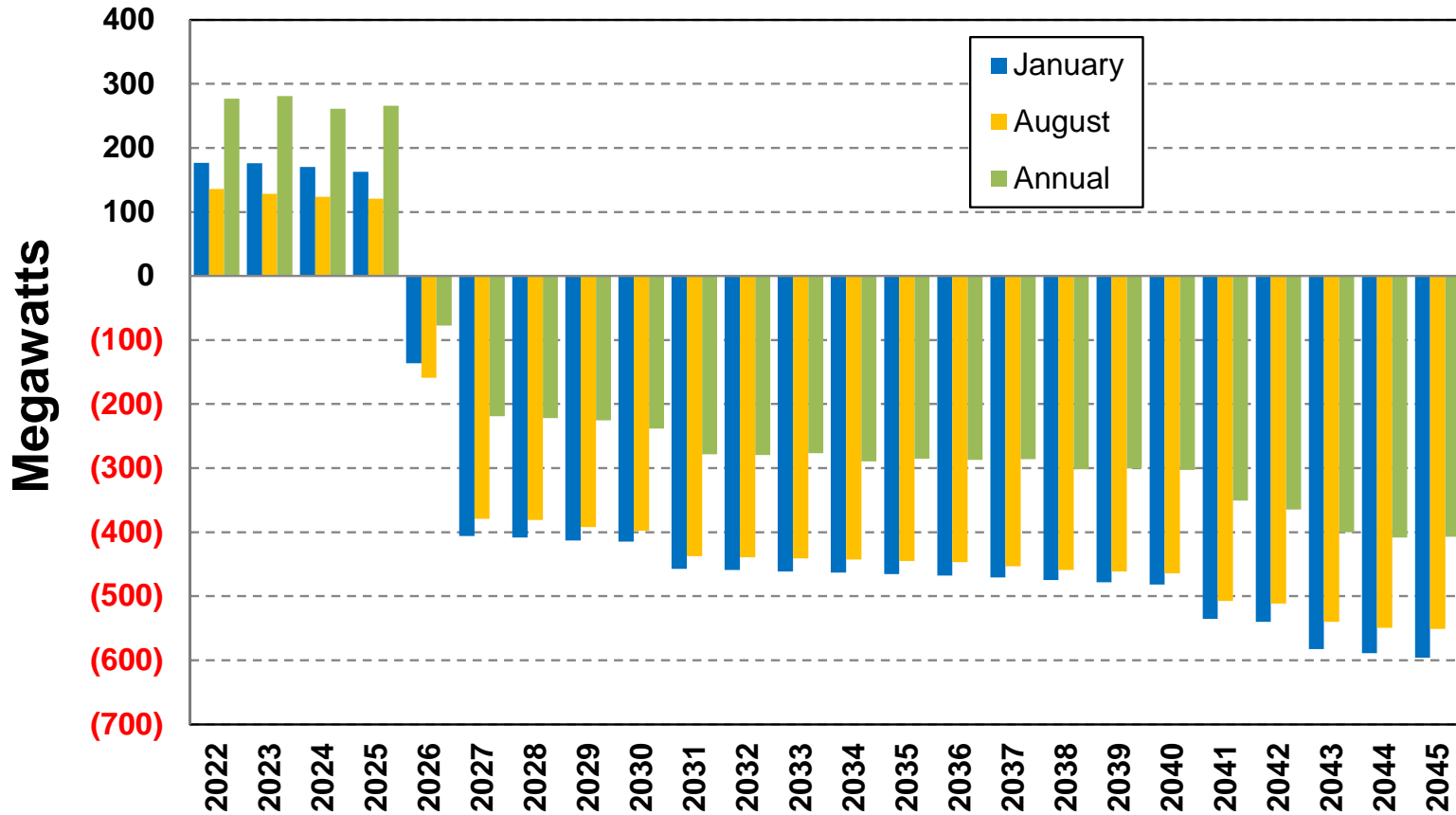



# Avista's Clean Energy Goal

## Goals

- 2027 – 100% carbon-neutral
- 2045 – 100% clean electricity

## How we will get there

- It's not just about generation – various solutions are necessary
- Maintain focus on reliability and affordability
- Natural gas plays an important part of a clean energy future
- Cost effective technologies need to emerge and mature



# Washington State Clean Energy Goals

- Energy Independence Act or Initiative 937
  - 15% of Washington retail load after 2020
  - Not modeling for this IRP since CETA takes us beyond 15%
  - Last IRP anticipated the inclusion of qualifying BPA and Wanapum generation, neither of which materialized
    - Avista decision to offset costs in lieu of BPA RECs
    - Inability to use Wanapum because of difference in hydro methodology
- Clean Energy Transformation Act
  - By 2025 – eliminate coal-fired resources from serving WA customers
  - By 2030 – electric supply must be greenhouse gas neutral,
  - By 2045 – electric supply must be 100% renewable or be generated from zero-carbon resources



# 2020 Renewable RFP Update

Chris Drake, Wholesale Marketing Manager  
Fourth Technical Advisory Committee Meeting  
November 17, 2020

# Justification

- Integrated Resource Plan (IRP) - Preferred Resource Strategy (PRS)
- Market indicators suggested competitive pricing for renewables
- Competition for preferred sites
- Corporate renewable goals – systemwide
  - Carbon neutral by 2027
  - 100% clean electricity by 2045
- If bids are not compelling, no obligation to contract
- Capacity Request For Information (or similar investigation) may be considered at a later date

## 2020 IRP Preferred Resource Strategy

Resource Type	Year	Capability (MW)
Montana wind	2022	100
NW wind	2022-2023	200
Kettle Falls upgrade	2026	12
Colstrip 3 & 4 exits portfolio	2026	-222
Rathdrum CT 1 & 2 upgrades	2026	24
Long-duration pumped hydro	2026	175
Lancaster PPA expires	2026	-257
Post Falls upgrade	2027	8
Montana wind	2027	200
Mid-Columbia hydro	2031	75
Northeast CTs retires	2035	-55
Long Lake 2 <sup>nd</sup> powerhouse	2035	68
Liquid-air storage (16 hours)	2036-2041	100
Wind (including PPA renewals)	2041-2043	300
Lithium-ion storage (4 hour)	2042-2045	300
Solar w/ storage (4 hours)	2044	55
4-hr Storage for Solar	2044	50
Supply-side resource net total (MW)		1,133
Supply-side additions through 2045 (MW)		1,667
Demand Response through 2045 (MW)		112
Energy Efficiency through 2045 (aMW)		187

# Cross-Departmental Review

- Power Supply
  - Wholesale marketing, resource planning, real-time, traders, credit and resource optimization
- Transmission
- Regulatory
- Insurance/Risk
- Corporate Communications
- Legal

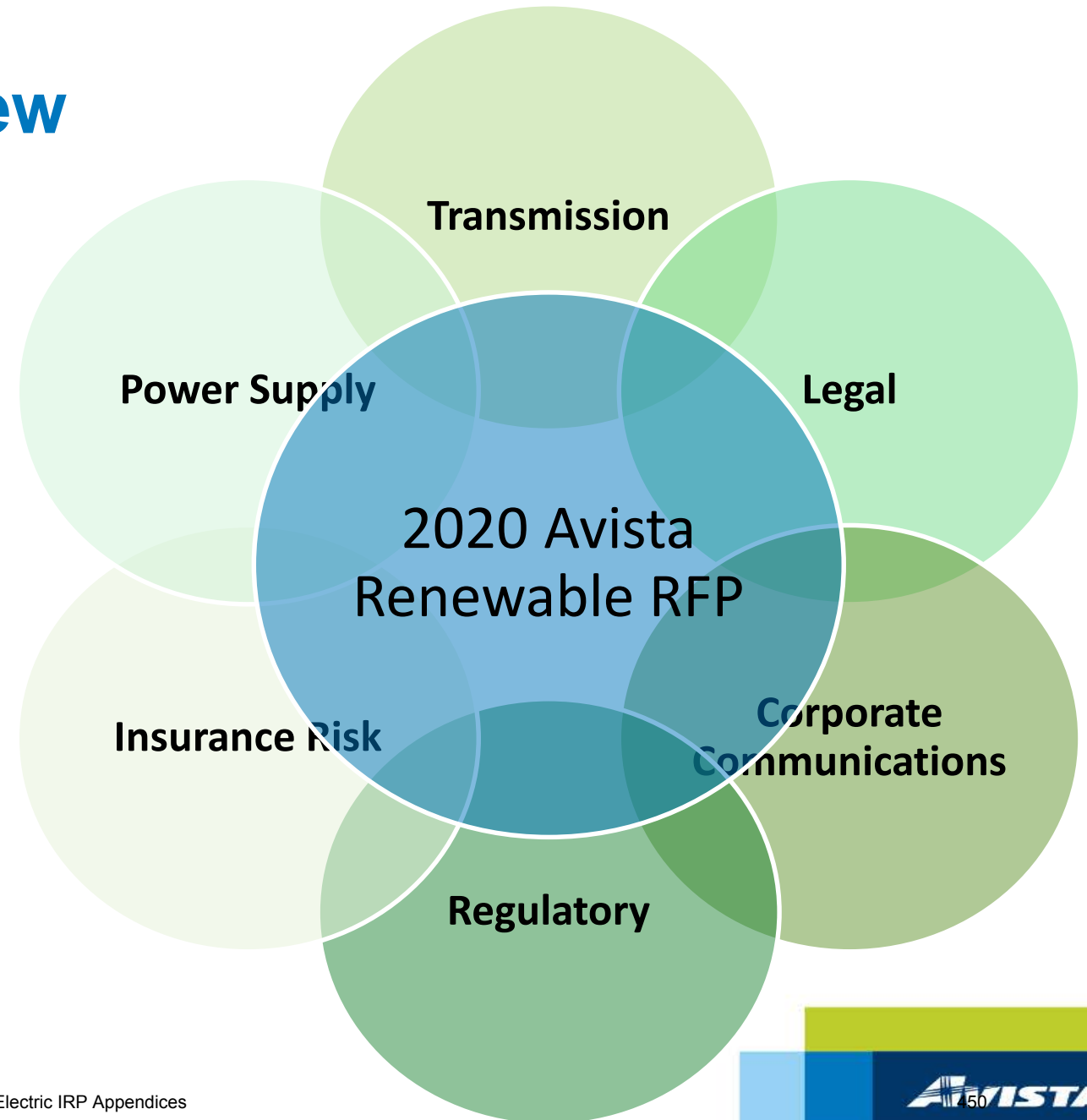

# New Elements of 2020 RFP

- New and existing projects were eligible to bid
  - New renewable resources
  - Nonemitting electric generation (existing)
- Updated evaluation methodology criteria
  - Risk Management, Net Price, Price Risk, Electric Factors, Environmental
  - Added Community Impact
    - Avista service territory economic impact
    - Equity provisions
    - Vulnerable and highly impacted communities
    - Energy security
- Published evaluation methodology

# RFP Communications

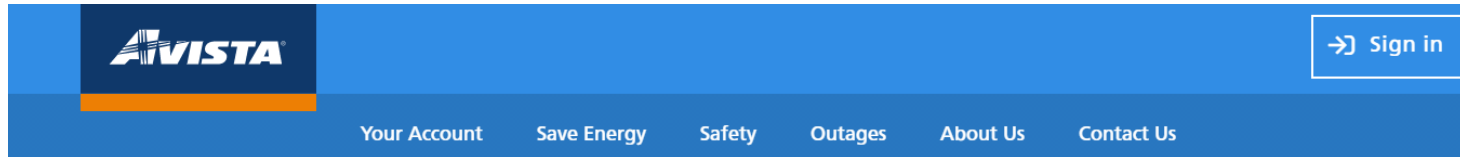

## Renewables RFP

Avista released a request for proposals on June 26, 2020 seeking pricing from renewable energy project developers capable of constructing, owning and operating up to 120 average MW's for delivery to Avista's electric utility service territory. Please respond to the RFP by completing the following forms and submitting them to 2020renewablerfp@avistacorp.com by July 22, 2020.

- [Request for proposals](#)
- [Exhibit A](#)
- [Exhibit B](#)
- [Exhibit C](#)
- [Exhibit D](#)

### 2020 RFP Target Schedule (subject to change)

- June 26, 2020 – Release RFP
- July 22, 2020 – Preliminary Information due
- July 31, 2020 – Short list identified
- August 21, 2020 – Detailed Proposals due from short-listed bidders
- August 21, 2020 through September 9, 2020 - Negotiations with short-listed bidders
- October 16, 2020 – Final bidder(s) selected
- December 15, 2020 – Final contracting complete with successful bidder(s)

**Please note:** The RFP does not constitute a legal offer or otherwise create a binding agreement or obligation to consummate any contemplated transaction. Any such obligation or agreement will be created only by the execution of definitive agreements, the provisions of which, if so executed, will supersede the RFP. Avista reserves the right to cancel the RFP at any time in its sole discretion.

#### Savings Tools

#### Energy Saving Advice

#### Tools For Your Business

#### Energy and Savings Profile

#### Green Options

- My Clean Energy
- Onsite Generation
- Community Renewable Options
- Electric Transportation
- Compressed Natural Gas

#### Avista Marketplace

#### Rebate Overview

#### Rebates: Washington

#### Rebates: Idaho

- Published on [www.myavista.com](http://www.myavista.com)
- Press Release
  - Local media contacts
  - GlobeNewswire distribution to over 600 national outlets

# Renewable Generation Need

- RFP for up to 300 MW renewables
- 2020 IRP's PRS model
  - 2022 Montana wind – 100 MW
  - 2022-2023 NW wind – 200 MW
- Anticipated proposals – mix of wind/solar/storage

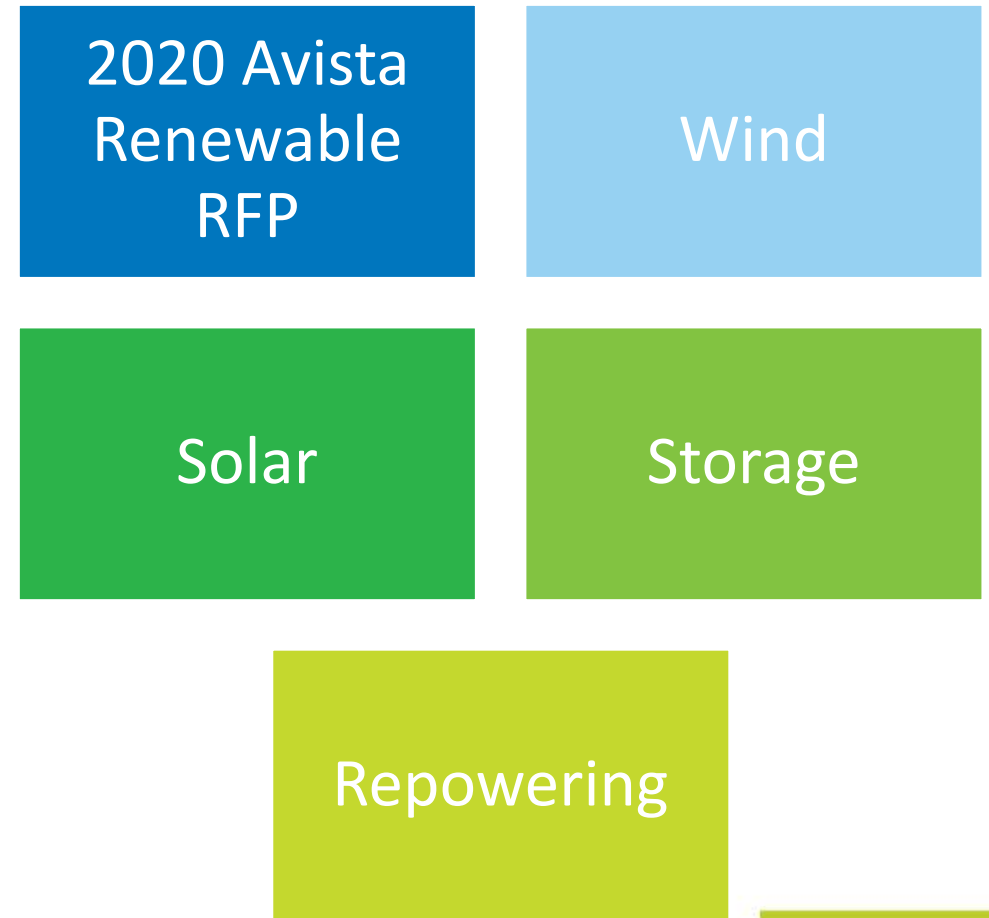



# Bids Received July 22, 2020

- 42 projects
- 25 developers
- 27 solar (many with battery options)
- 13 wind (some with battery option)
- 1 hydro
- 1 biomass

# RFP Initial Reactions

- Good selection of shovel ready and existing projects
- Good geographic distribution
  - Projects throughout Northwest with majority in Washington, then Montana, Idaho and Oregon
- Prices were higher than 2018 RFP
  - Sunsetting PTC
  - Increased construction costs
- Multiple capacity projects submitted
  - Hydro
  - Biomass

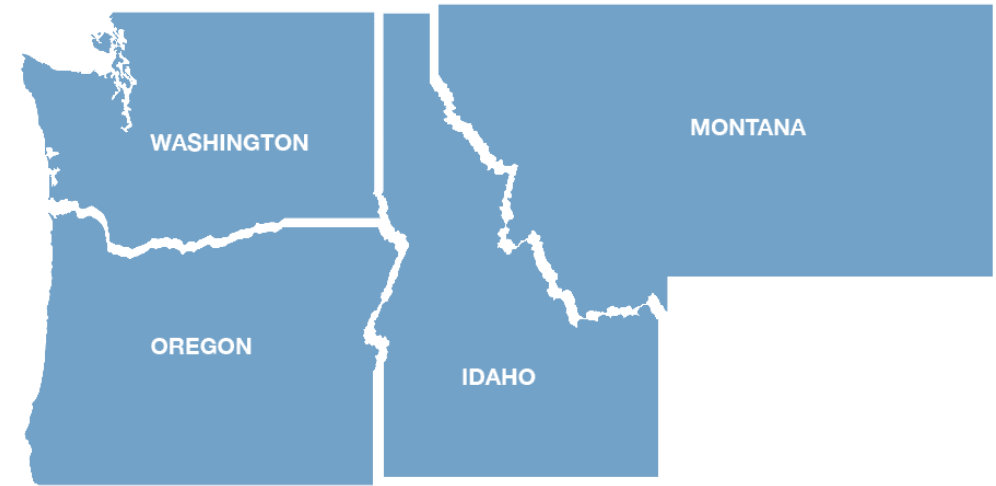

# 2020 Avista Renewable RFP Evaluation Methodology

## General Qualifications

- Compatibility with resource need
- Site control
- Financial plan to bring project to completion
- Credit requirements
- Procurement plan
- Project completion no later than December 31, 2023

## Evaluation Criteria

- Risk Management - Credit and Developer Experience
- Net Price - Nominal levelized cost / MWh
- Price Risk - Fixed price, construction, fuel supply
- Electric Factors - Interconnection, transmission, technology
- Environmental - Permitting
- Community Impact - Community involvement, Avista service territory, vulnerable populations

# 2020 Target Schedule (and Milestones Completed)

- ✓ June 26, 2020 – RFP Released
- ✓ July 22, 2020 – Preliminary Information Due
- ✓ July 31, 2020 – Short-list identified and notified (along with other bidders)
- ✓ August 21, 2020 – Detailed proposals received from short-list
- ✓ October 16, 2020 – Final bidder(s) selected for continued review
- December 31, 2020 – Contract negotiation(s)

# 2020 RFP Next Steps

- Continue to address specific attributes within proposal(s)
- Contract negotiations with successful project(s)
- Continue internal review to make a final determination



# PRiSM Model Overview

James Gall, Electric IRP Manager  
Fourth Technical Advisory Committee Meeting  
November 17, 2020

# What is PRISM?

- Preferred Resource Strategy Model
- Mixed Integer Program (MIP) used to select new resources to meet resource needs of our customers



Excel

The user interface



The solver interface



The solver

# New PRiSM Features for 2021 IRP

- Significant changes were made to this IRP's model due to individual state policies.
  - Model purpose: Same as before with additional constraints and options.
  - New Constraints: Must meet individual state L&R balance requirements and clean energy goals.
  - New Options: Resources can be added for a specific state or the system.
  - New Outputs: State level cost and rate estimates along with resource strategies.
  - Model will be fully available and published on IRP website.
  - Model is continually being vetted.



# Objective Function

Intro to linear programming: <https://www.youtube.com/watch?v=Uo6aRV-mbeg>

Minimize: (WA “Societal” NPV<sub>2022-45</sub>) + (ID NPV<sub>2022-45</sub>)

Where:

WA NPV<sub>2022-45</sub> = Market Value of Load + Existing & Future Resource Cost/Operating Margin + Social Cost of Carbon + EE TRC

ID NPV<sub>2022-45</sub> = Market Value of Load + Existing & Future Resource Cost/Operating Margin + EE UTC

Subject to:

- Generation Availability & Timing
- Energy Efficiency Potential
- Demand Response Potential
- Winter Peak Requirements
- Summer Peak Requirements
- Annual Energy Requirements
- Clean Energy Goals
- T&D Constraints

Optimization Tolerance: 0.0001 or 1,500 seconds (Note: certain studies longer solution times allowed)

# Optimized Cost vs. Actual Costs

- Objective function includes social costs that are not part of utility revenue requirement.
- This is used for resource optimization only.
- Social costs may include:
  - Energy Efficiency
    - TRC
    - Non-energy benefits
    - Power Act 10% adder
    - T&D Savings
  - Social Cost of Carbon
- Actual costs illustrate expected cost ratepayers will pay.
- Estimate annual revenue requirements.
- Estimate average rates.

# Aurora Integration

- Aurora's price forecast and resource dispatch are inputs into PRiSM.
- Each **supply resource's** operations is included by iteration.
  - Includes MWh, GHG, Revenue, Fuel Cost, VOM costs.
- **Avista load and existing contracts** are also entered in totals.
- **Energy efficiency** load shapes are marked to market and used for the energy value of these programs.
- **Demand response** options are not modeled in Aurora, but use hourly price results for a market value.

# Thermal Resources

- Model may retain or exclude specific resources in any year.
  - Retirements are for both states (except Colstrip).
  - No re-allocation of existing resources between states.
- Includes major future capital spend for continued operation along with O&M costs.
- Resource costs and benefits are allocated using PT ratio (65% WA, 35% ID).
- Lancaster PPA expires in October 2026.
- Northeast assumes retirement in 2035 & Boulder Park in 2040.
- Kettle Falls CT is excluded from retirement option, but is excluded from winter peak due to pending pipeline review.
- Colstrip must be removed in Washington by 2025.
  - Model can remove earlier or retain for Idaho.
  - Washington's share of cost after 2025 are not included in model.

# Hydro Resources

- Available for full length of study.
- Post Falls assumes rebuild in 2025 (found cost effective in 2021 IRP).
- Energy, capacity, and clean energy attributes split between states using PT ratio (65% WA/35% ID).

# Other Existing “Resources”

- PURPA
  - CETA has provision for in-state PURPA generation reducing clean energy obligation.
  - For modelling purposes, generation is allocated to each state it qualifies under PURPA.
- Other Wholesale Contracts
  - Current PPAs are allocated to each state using PT ratio.
  - Except for Adam’s Neilson Solar- fully allocated to Washington.
  - PURPA related resales are fully allocated to state it qualifies for under PURPA
- Renewable Energy Credits (RECs)
  - Each state receives “RECs” from its “PT ratio” share of resources.
  - Model allows for sale of RECs between states subject to limits.

# Energy Efficiency

## Washington

- AEG provides EE potential by year and program
  - Winter peak savings
  - Summer peak savings
  - Annual average savings
- Electrical savings are grossed up for T&D losses
- Benefit of T&D Capital Avoidance (\$25.35 per kW-yr)
- Total Resource Cost (TRC) test
- Add value for non-energy benefits (\$23 per MWh)
- Power Act 10% adder for energy and capacity value
- Social Cost of Carbon using regional incremental emission rates per MWh
- Included in L&R constraints to avoid new supply resource options

## Idaho

- AEG provides EE potential by year and program
  - Winter peak savings
  - Summer peak savings
  - Annual average savings
- Electrical savings are grossed up for T&D losses
- Benefit of T&D Capital Avoidance (\$25.35 per kW-yr)
- Utility Cost Test (UCT) for cost effectiveness
- Included in L&R constraints to avoid new supply resource options

# Demand Response

- Programs available in each state determined by AEG.
- AEG estimated capital amortized over 5 years and a levelized cost is created by combining the O&M costs.
- Projects must ramp in over time (except large industrial).
  - 25 MW of industrial DR for Washington
- Water heating is different between states:
  - WA includes CTA-2045
  - DLC water heating in ID
- Energy arbitrage and savings is included based on 50% of potential use.
  - 10% preference adder included for Washington.
- Peak Credit is using 2020 IRP estimate of 60%.
  - Additional studies may be available to validate.
  - Based on prior IRP- this estimate could be too high.



# Supply-Side Options

- Uses levelized fixed and variable costs for potentially owned resources (i.e. natural gas, storage).
- Uses PPA \$/MWh or \$/kW-yr costs for resources.
- All generation costs are available on the IRP website.
- Washington PPA options includes rate of return for clean resources.
- Resources must be added in increments of probable size of actual acquisition- not any value- this assumption can increase cost or change resource strategy.

# Clean Energy Goals

- **Washington**

- 100% clean energy (carbon neutral) by 2030
- 100% clean energy by 2045

- **MAJOR ASSUMPTIONS:**

- By 2030, Washington's clean energy must equal 100% of net retail sales; 20% of this total may come from RECs.
  - Only REC purchases assumed are from Idaho customers at \$7.50/MWh escalating
- 2045, 100% goal of all 100% of electrons clean is not modeled at this time (likely 2024 IRP).
- Between 2030 and 2045 REC transfers decline to zero.
- Prior to 2030 REC transfers are limited to non-hydro resources to encourage early acquisition.

- **Idaho**

- No clean energy requirement.
- Idaho is allowed to sell REC's to Washington LSE.
- Other REC sales to other parties are not modeled.
- Scenarios will show cost of additional renewable energy acquisition.

# Greenhouse Gas Emissions

- The model estimates the GHG emissions for thermal resource dispatch.
  - Market purchase/sale effects are estimated using the regional average emission rate.
  - Storage resources include a market based GHG adder.
- Societal emissions saved from Energy Efficiency using an incremental emissions approach are estimated.
- Includes upstream emissions for natural gas resources.
- Construction and operation emissions are included.

# Social Cost of Carbon or Social Cost of Greenhouse Gas

## Washington

- Costs are included for resource dispatch of new thermal & storage options.
- Cost are also included for existing natural gas-fired resources.
- Energy Efficiency receives a social credit for emission savings.
- No cost are included for market transactions, except for storage resources.
  - This would give extra incentive to renewables by valuing the social cost of carbon on non-Avista resources. [Potential scenario]
  - Model time step doesn't allow for SCC on purchases only.

## Idaho

- No direct cost of GHG is included.
- Objective function is 65% Washington Cost- therefore existing resources are influenced by this cost and could have effects on Idaho.
- A scenario using the Washington methodology will be studied.

# Transmission

- Resources have either a capital investment or a wheeling charge.
  - Capital investments are based on the transmission cost estimates from the September 2020 TAC 3 meeting.
- Resource options in the Rathdrum, Idaho area are a challenge.
  - Approximately 100 MW can be added without significant investment.
  - Over 100 MW may either require additional infrastructure or Remedial Action Scheme (RAS).
    - RAS has not been studied
  - Avista has resource options in the area without new transmission (i.e. Lancaster), but if Lancaster operates and Avista builds new resources would require an investment or RAS.
  - **For this analysis no additional Rathdrum transmission is assumed until either Lancaster is ruled out from an RFP or RAS is determined to not be an option.**
    - By including the additional transmission cost could either create a portfolio where Idaho must pursue a more costly option- an RFP needs to decide this rather than an IRP without cost of a Lancaster extension.

# Resource Adequacy Check

- To the furthest extent possible, portfolios will be studied for resource adequacy for 2025, 2030, and 2040.
  - Each study takes 3 days to complete; Avista has only 2 machines capable of this work.
- If a portfolio fails the adequacy test- additional capacity will be required or noted.
- Avista does not expect to complete all studies for the draft IRP release.
  - Although studies will be conducted through February for the final draft portfolios requiring this work.
  - All other studies will need to rely on the planning margin for its resource adequacy test.
- Reliability data input files are still in process and results are not available at this time.

# Equity Provisions

- Avista previously identified potential areas within its system qualifying for VP/HIC status, although final determination is still ongoing.
- A baseline analysis for cost and reliability/resilience has been completed.
- Avista is developing an Equity Advisory Group (EAG).
  - EAG will determine final VP/HIC determinants.
  - Develop outreach plan for each community to understand energy needs and preferences.
  - Study solutions and develop programs to meet needs of the communities.
- Process to develop a solid plan for these VP/HIC communities will not be available for this IRP.



# Least “Reasonable” Cost Strategy & Baseline Analysis

## “Not Preferred Resource Strategy Yet”

James Gall, Electric IRP Manager  
Fourth Technical Advisory Committee Meeting  
November 17, 2020



# Safe Harbor Statement

This document contains forward-looking statements. Such statements are subject to a variety of risks, uncertainties and other factors, most of which are beyond the Company's control, and many of which could have a significant impact on the Company's operations, results of operations and financial condition, and could cause actual results to differ materially from those anticipated.

For a further discussion of these factors and other important factors, please refer to the Company's reports filed with the Securities and Exchange Commission. The forward-looking statements contained in this document speak only as of the date hereof. The Company undertakes no obligation to update any forward-looking statement or statements to reflect events or circumstances that occur after the date on which such statement is made or to reflect the occurrence of unanticipated events. New risks, uncertainties and other factors emerge from time to time, and it is not possible for management to predict all of such factors, nor can it assess the impact of each such factor on the Company's business or the extent to which any such factor, or combination of factors, may cause actual results to differ materially from those contained in any forward-looking statement.

# Other Caveats

- Clean Energy Transformation Act (CETA) rules and requirements are not complete.
  - This is Avista’s best estimate of known requirements.
- Avista is negotiating with the renewable Request for Proposals (RFP) shortlist bidders
  - This may change the results of the resource plan due to a potential contract.
- IRP resource options are primarily “new” resource options- RFP will determine whether or not existing resources can be acquired at similar or lower cost than “new” options.
- Avista may not be able to physically retire or exit certain resources as the IRP PRiSM model determines.
- No future state specific resource cost allocation agreement has been made.
- Forward looking rates include non-modeled power supply cost escalating at 2% per year-
  - **DO NOT TAKE THIS AS A RATE FORECAST**
  - This is for informational purposes only

# Energy Efficiency Results

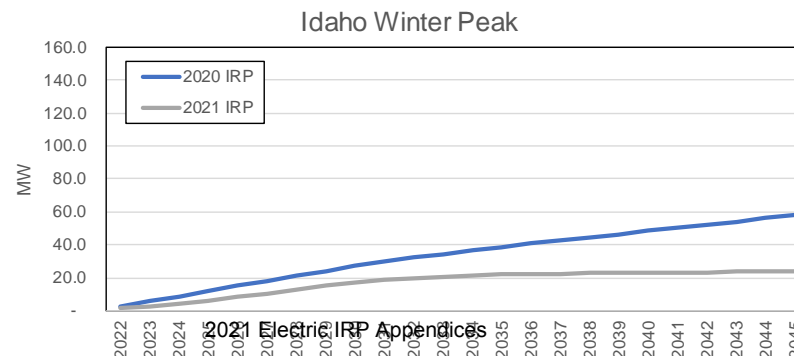
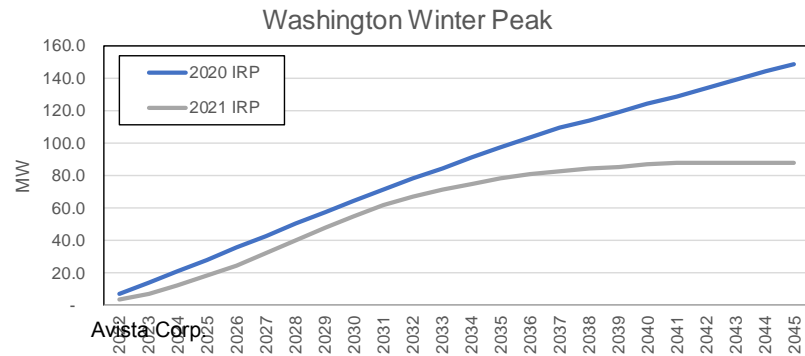
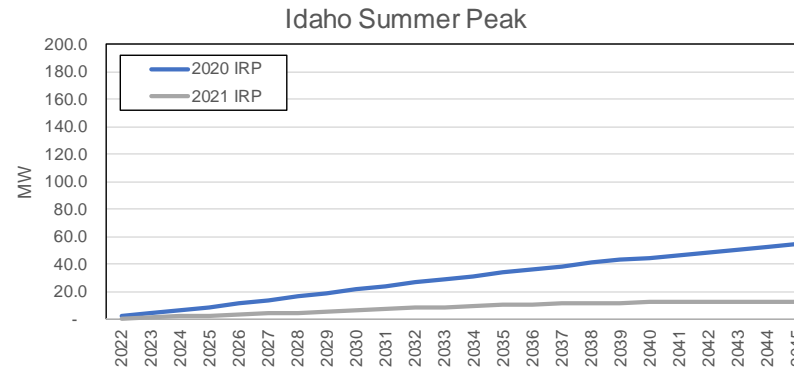
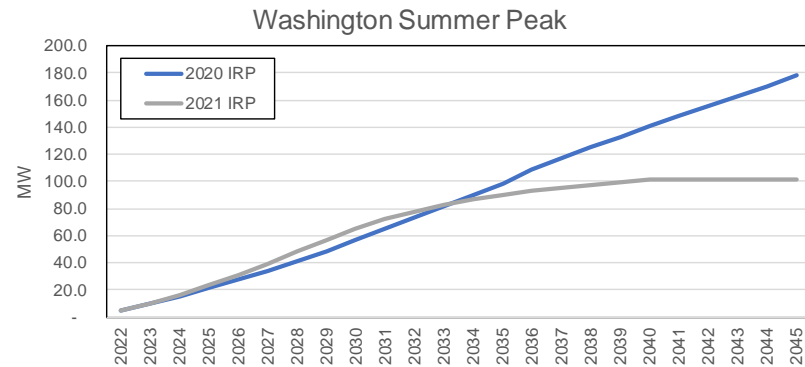
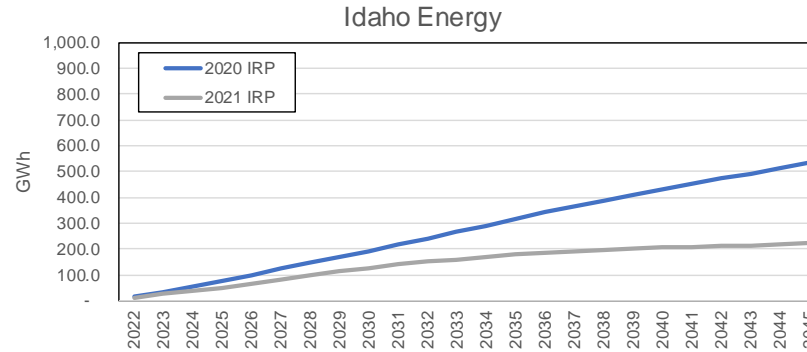
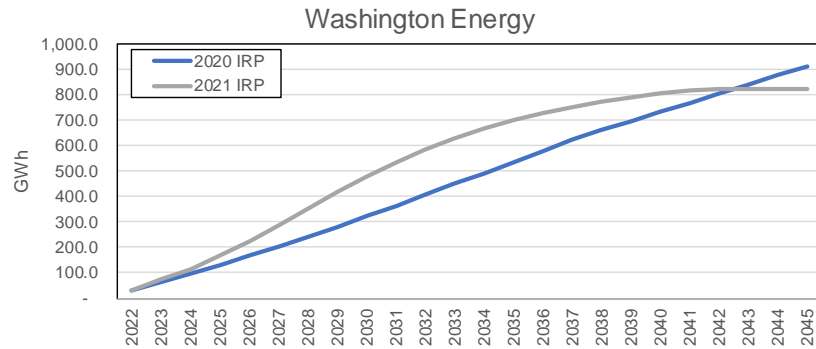

**NOTE:**  
Energy Efficiency results do not materially impact supply resource strategy.

Supply resource strategy is based on the load forecast for both energy and peak.

EE is first estimated, then added to the load forecast; the model then picks economic EE to have net load equal to the load forecast

# Cumulative Energy Efficiency End Use Results (GWh)

	2023		2031		2045	
	WA	ID	WA	ID	WA	ID
Appliances	0.7	0.1	6.6	0.8	15.6	2.7
Cooling	6.4	0.5	41.7	2.8	61.2	7.0
Electronics	1.1	0.2	15.2	4.8	27.1	9.3
Exterior Lighting	4.3	1.4	24.8	7.8	37.2	14.3
Food Preparation	0.1	0.0	2.2	0.4	5.9	0.9
Interior Lighting	21.1	13.0	103.6	49.3	176.3	89.6
Miscellaneous	1.5	0.3	16.0	2.8	36.0	5.5
Motors	4.9	3.4	35.3	24.0	41.3	27.0
Office Equipment	0.6	0.0	3.6	0.0	6.2	0.0
Process	0.7	0.1	4.1	1.1	4.5	1.4
Refrigeration	8.3	0.3	60.9	2.3	70.0	2.6
Space Heating	13.1	3.5	122.9	30.3	175.4	39.9
Ventilation	5.3	0.7	31.0	5.2	46.1	12.5
Water Heating	4.6	1.4	65.9	8.3	120.6	9.7
<b>Total</b>	<b>72.7</b>	<b>25.1</b>	<b>533.7</b>	<b>140.0</b>	<b>823.4</b>	<b>222.3</b>

# Cumulative Energy Efficiency Segment Results (GWh)

	2023		2031		2045	
	WA	ID	WA	ID	WA	ID
College	2.7	0.7	13.8	4.2	19.5	7.5
Grocery	6.8	0.2	47.6	1.4	56.6	1.7
Health	2.7	0.9	14.5	4.7	23.0	8.1
Industrial	12.0	7.9	62.5	41.1	91.4	61.1
Large Office	6.6	1.3	43.6	8.8	67.5	16.5
Lodging	1.4	0.6	8.9	2.9	13.2	4.9
Low Income	3.4	1.7	40.4	10.7	60.8	13.2
Miscellaneous	6.1	1.9	41.5	10.7	61.3	19.1
Mobile Home	0.7	0.2	7.2	1.4	14.2	2.1
Multi-Family	0.5	0.2	7.6	1.2	16.6	1.9
Restaurant	2.1	0.2	15.1	1.6	20.2	2.3
Retail	5.6	2.0	35.8	10.3	52.8	17.9
School	3.1	0.1	18.5	0.4	28.7	0.8
Single Family	14.4	5.1	147.6	28.6	250.3	42.8
Small Office	2.4	1.1	16.9	7.4	26.5	13.5
Warehouse	2.4	0.9	12.4	4.7	20.8	8.9
<b>Total</b>	<b>72.7</b>	<b>25.1</b>	<b>533.7</b>	<b>140.0</b>	<b>823.4</b>	<b>222.3</b>

2021 Electric IRB Appendices

# Higher Washington Energy Efficiency Goals

## More Aggressive Ramp Rates & Higher Avoided Costs

Biennial Conservation Target (MWh)	Based on 2021 IRP	Based on 2020 IRP
CPA Pro-Rata Share	106,740	72,338
Distribution and Street Light Efficiency	219	504
EIA Target	106,959	72,842
Decoupling Threshold	5,348	3,642
Total Utility Conservation Goal	112,307	76,484
Excluded Programs (NEEA)	-14,016	-14,016
Utility Specific Conservation Goal	98,291	62,468
Decoupling Threshold	-5,348	-3,642
EIA Penalty Threshold	92,943	58,826

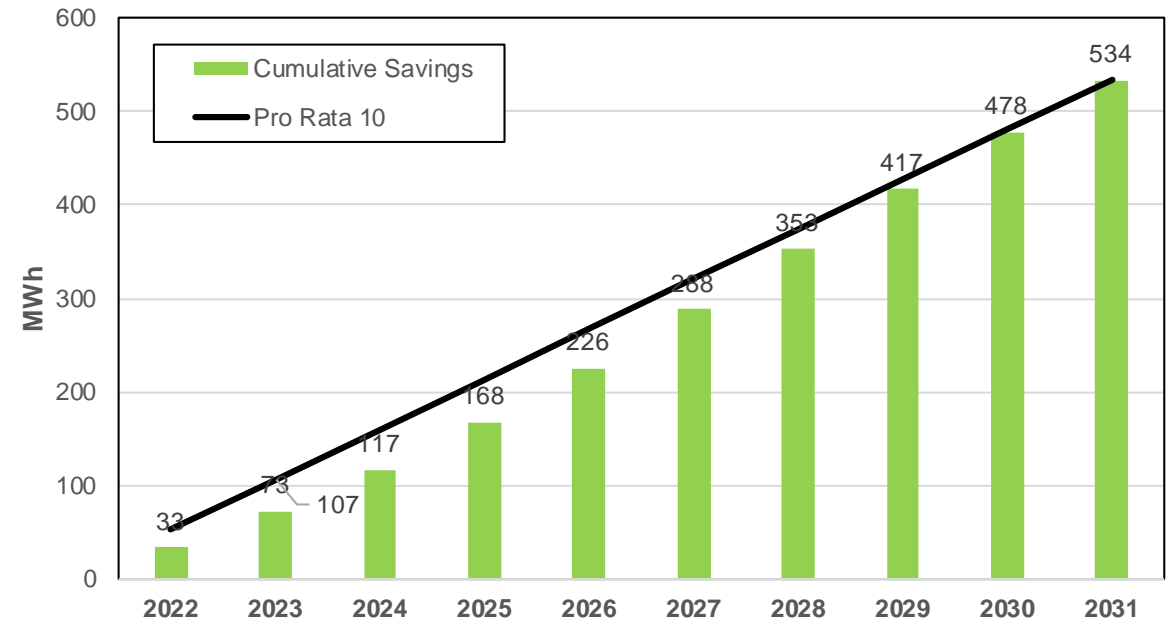

# Stacked 20-Year Levelized Energy Efficiency Avoided Cost (WA)

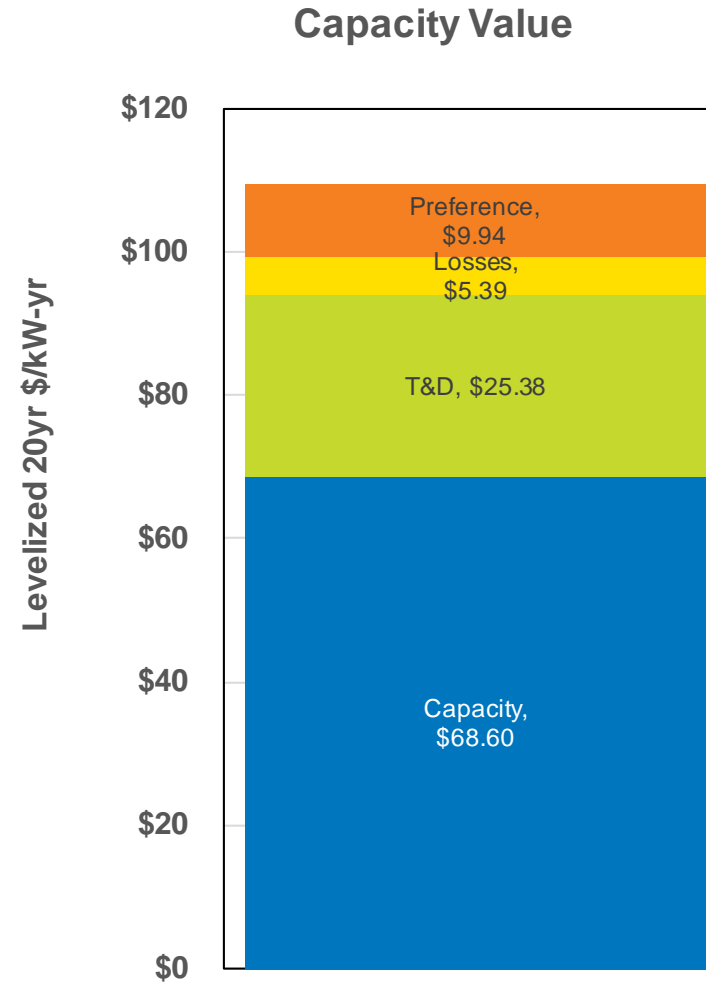
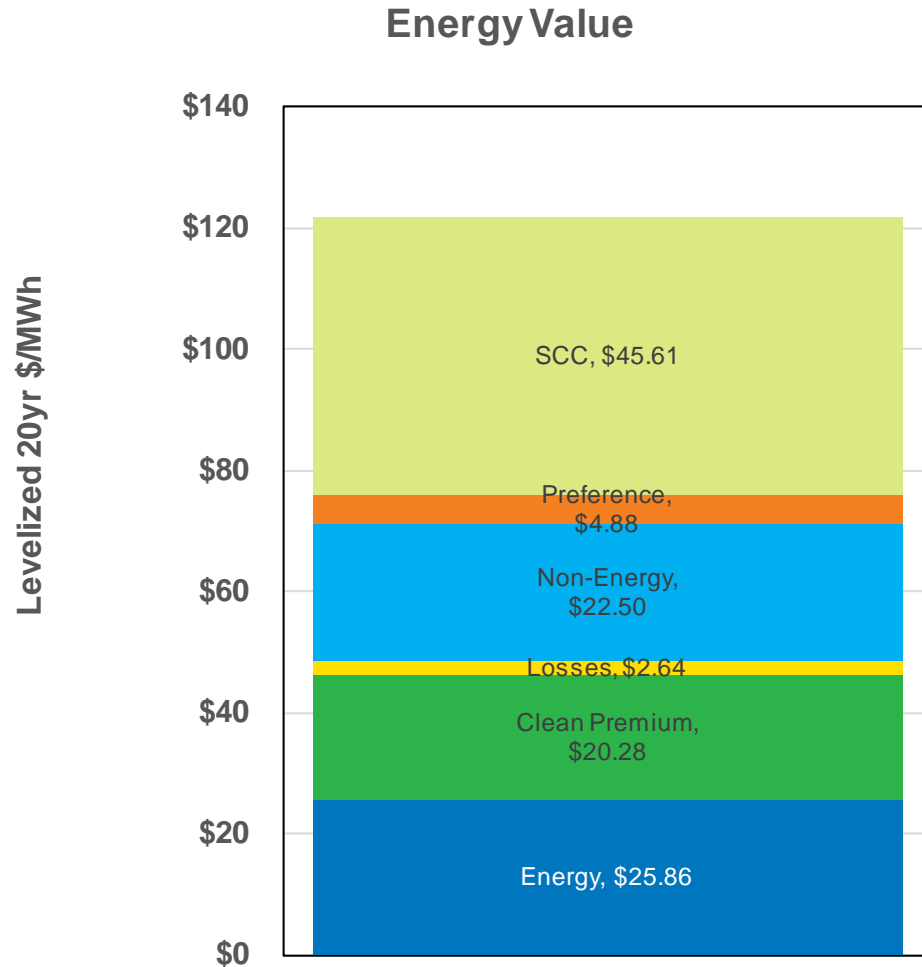

# Stacked 20-Year Levelized Energy Efficiency Avoided Cost (ID)

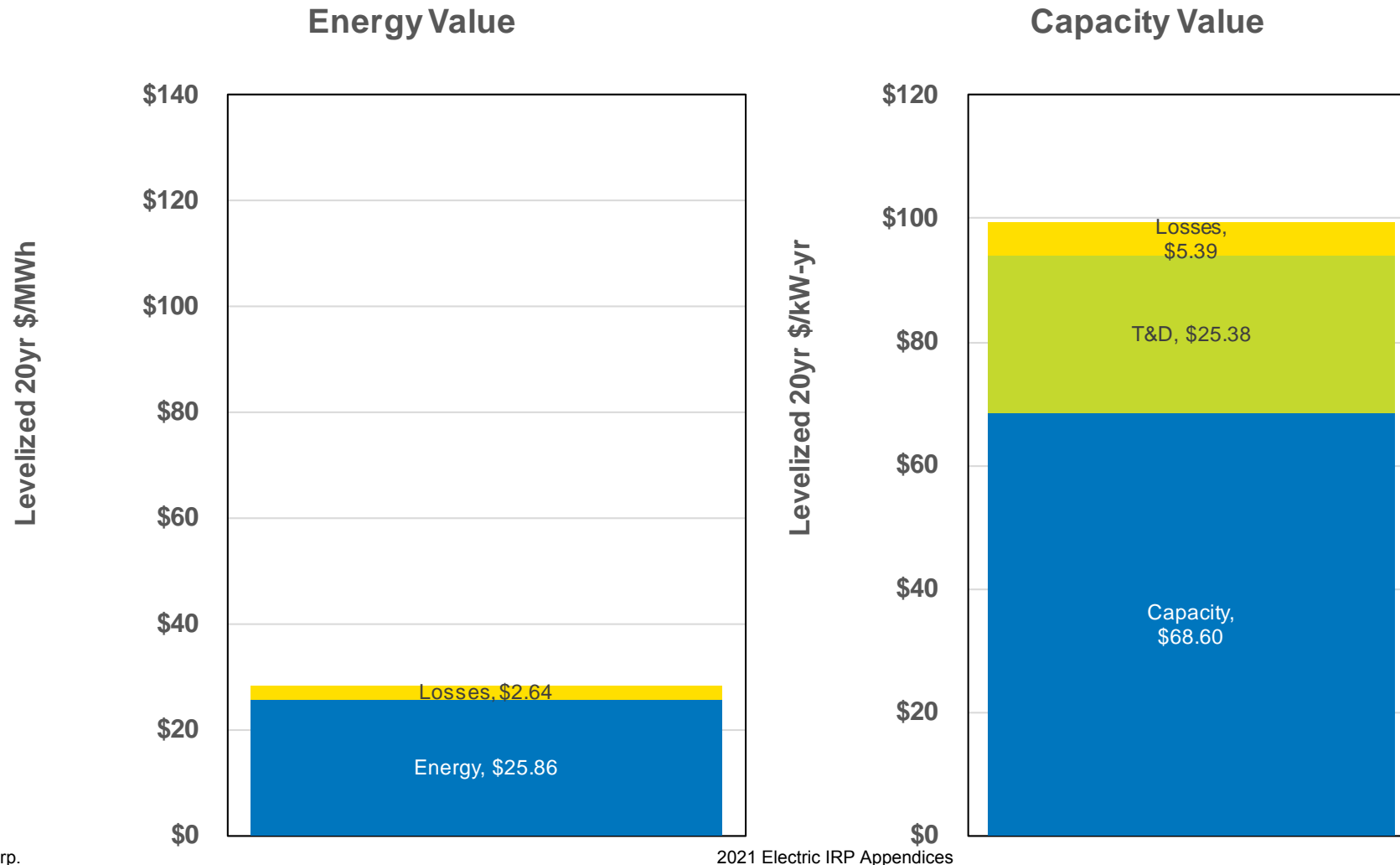



# Demand Response

Program	Washington	Idaho
Time of Use Rates	2 MW (2024)	2 MW (2030)
Variable Peak Pricing	7 MW (2024)	6 MW (2030)
Large C&I Program	25 MW (2027)	n/a
DLC Smart Thermostats	7 MW (2030)	n/a
Third Party Contracts	15 MW (2031)	n/a
Behavioral Programs	1 MW (2039)	n/a
Total	56 MW	8 MW

Note: DR programs in another state for the benefit of the other state is not modeled

# 2022-2025 Supply Side Resource Changes

**2022:** Economic to exit out of Colstrip 3 & 4 (Both)

**2023:** 100 MW of Montana Wind (WA)

**2024:** 50 MW of Montana Wind (WA)

**2025:** No Action

**NOTE:** Renewable RFP may change this strategy

# 2026-2029 Supply Side Resource Changes

**2026:** 50 MW Montana Wind (WA)

48 MW NG SCCT (Both)

Lancaster CCCT contract ends (Both)

**2026/27:** 84 MW NG SCCT (ID)

84 MW NG SCCT (Both)

12 MW Upgrade Kettle Falls (Both)

**2028:** 50 MW Montana Wind (WA)

**2029:** 50 MW Solar + 50 MW 4-Hour Storage (Both)

**NOTE:** Renewable RFP may change this strategy

# 2030-2033 Supply Side Resource Changes

**2030:** No Action

**2031:** 75 MW Hydro Contract Renewal (WA)

**2032:** No Action

**2033:** No Action

**NOTE:** Renewable RFP may change this strategy

## 2034-2037 Supply Side Resource Changes

**2034:** 5 MW Rathdrum CT Upgrade (Both)

**2035:** 50 MW Solar + 50 MW 4-Hour Storage (Both)

Northeast Retires (Both)

**2036:** 50 MW Hydrogen SCCT (WA)

55 MW NG SCCT (ID)

**2037:** No Action

# 2038-2045 Supply Side Resource Changes

**2038:** 50 MW Montana Wind (WA)

**2039:** No Action

**2040:** 50 MW Solar + 50 MW 4-Hour Storage (Both)

**2041:** 50 MW Solar + 50 MW 4-Hour Storage (WA)

50 MW Montana Wind (WA)

Boulder Park Retires (Both)

**2042:** 50 MW Montana Wind (WA)

50 MW Solar + 50 MW 4-Hour Storage (Both)

**2043:** 50 MW Solar (WA)

100 MW Solar + 100 MW 4-Hour Storage (Both)

**2044:** 50 MW Solar + 50 MW 4-Hour Storage (ID)

**2045:** 150 MW Solar (WA)

30 MW Storage (ID)

# Least Reasonable Cost Resource Selection (MW)

Nameplate MW	2022	2023	2024	2025	2026	2027	2028	2029	2030	2031	2032	2033	2034	2035	2036	2037	2038	2039	2040	2041	2042	2043	2044	2045
<b>Shared System Resource</b>																								
NG CT	0	0	0	0	48	84	0	0	0	0	0	0	0	0	0	0	0	0	0	0	0	0	0	0
Solar	0	0	0	0	0	0	0	50	0	0	0	0	0	50	0	0	0	0	50	0	50	100	0	0
Storage Added to Solar	0	0	0	0	0	0	0	50	0	0	0	0	0	50	0	0	0	0	50	0	50	100	0	0
Wind	0	0	0	0	0	0	0	0	0	0	0	0	0	0	0	0	0	0	0	0	0	0	0	0
Storage	0	0	0	0	0	0	0	0	0	0	0	0	0	0	0	0	0	0	0	0	0	0	0	0
Hydrogen	0	0	0	0	0	0	0	0	0	0	0	0	0	0	0	0	0	0	0	0	0	0	0	0
Other- (Clean Capacity)	0	0	0	0	0	0	0	0	0	0	0	0	0	0	0	0	0	0	0	0	0	0	0	0
Thermal Upgrade	0	0	0	0	0	12	0	0	0	0	0	0	5	0	0	0	0	0	0	0	0	0	0	0
Hydro	0	0	0	0	0	0	0	0	0	0	0	0	0	0	0	0	0	0	0	0	0	0	0	0
<b>Washington</b>																								
NG CT	0	0	0	0	0	0	0	0	0	0	0	0	0	0	0	0	0	0	0	0	0	0	0	0
Solar	0	0	0	0	0	0	0	0	0	0	0	0	0	0	0	0	0	0	0	50	0	50	0	150
Storage Added to Solar	0	0	0	0	0	0	0	0	0	0	0	0	0	0	0	0	0	0	0	50	0	0	0	0
Wind	0	100	50	0	50	0	50	0	0	0	0	0	0	0	0	0	50	0	0	50	50	0	0	0
Storage	0	0	0	0	0	0	0	0	0	0	0	0	0	0	0	0	0	0	0	0	0	0	0	0
Hydrogen	0	0	0	0	0	0	0	0	0	0	0	0	0	50	0	0	0	0	0	0	0	0	0	0
Other- (Clean Capacity)	0	0	0	0	0	0	0	0	0	0	0	0	0	0	0	0	0	0	0	0	0	0	0	0
Thermal Upgrade	0	0	0	0	0	0	0	0	0	0	0	0	0	0	0	0	0	0	0	0	0	0	0	0
Hydro	0	0	0	0	0	0	0	0	0	75	0	0	0	0	0	0	0	0	0	0	0	0	0	0
DR Capability	0	0	1	4	9	37	37	37	38	42	47	54	56	56	56	56	56	56	56	57	57	56	56	56
EE- Winter Capacity	3	4	5	6	7	7	8	8	7	6	5	4	4	3	2	2	2	2	1	1	1	1	0	0
EE- Summer Capacity	5	5	6	7	8	8	9	8	8	7	6	5	4	3	3	2	2	2	2	0	0	0	0	0
<b>Idaho</b>																								
NG CT	0	0	0	0	0	84	0	0	0	0	0	0	0	0	55	0	0	0	0	0	0	0	0	0
Solar	0	0	0	0	0	0	0	0	0	0	0	0	0	0	0	0	0	0	0	0	0	0	50	0
Storage Added to Solar	0	0	0	0	0	0	0	0	0	0	0	0	0	0	0	0	0	0	0	0	0	0	50	0
Wind	0	0	0	0	0	0	0	0	0	0	0	0	0	0	0	0	0	0	0	0	0	0	0	0
Storage	0	0	0	0	0	0	0	0	0	0	0	0	0	0	0	0	0	0	0	0	0	0	0	30
Hydrogen	0	0	0	0	0	0	0	0	0	0	0	0	0	0	0	0	0	0	0	0	0	0	0	0
Other- (Clean Capacity)	0	0	0	0	0	0	0	0	0	0	0	0	0	0	0	0	0	0	0	0	0	0	0	0
Thermal Upgrade	0	0	0	0	0	0	0	0	0	0	0	0	0	0	0	0	0	0	0	0	0	0	0	0
Hydro	0	0	0	0	0	0	0	0	0	0	0	0	0	0	0	0	0	0	0	0	0	0	0	0
DR Capability	0	0	0	0	0	0	0	0	1	3	7	9	10	10	10	10	9	9	9	9	9	9	9	8
EE- Winter Capacity	1	1	2	2	2	2	2	2	2	2	1	1	1	0	0	0	0	0	0	0	0	0	0	0
EE- Summer Capacity	1	1	1	1	1	1	1	1	1	1	1	1	1	1	1	0	0	0	0	0	0	0	0	0

Note: DR is cumulative due to the small changes year to year

# Clean Energy Share (aMW)

Washington

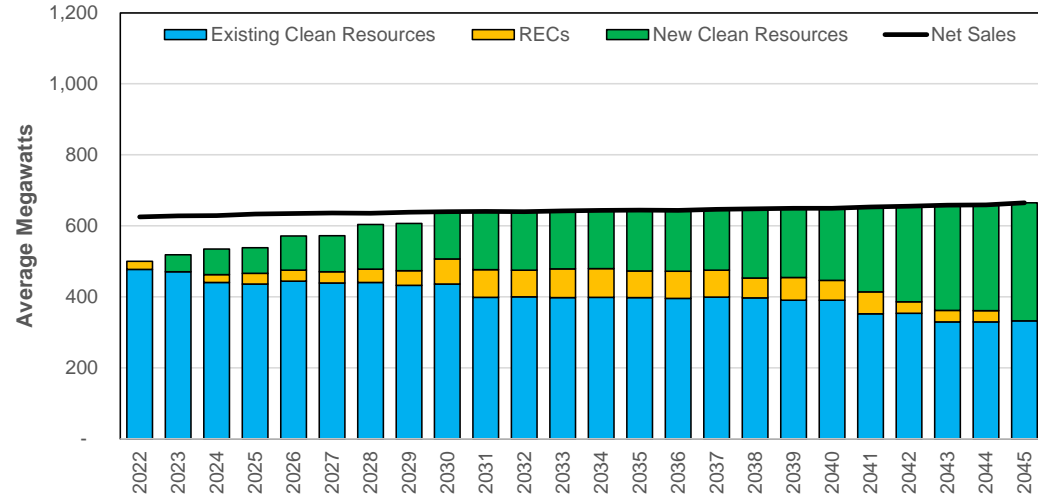

Idaho

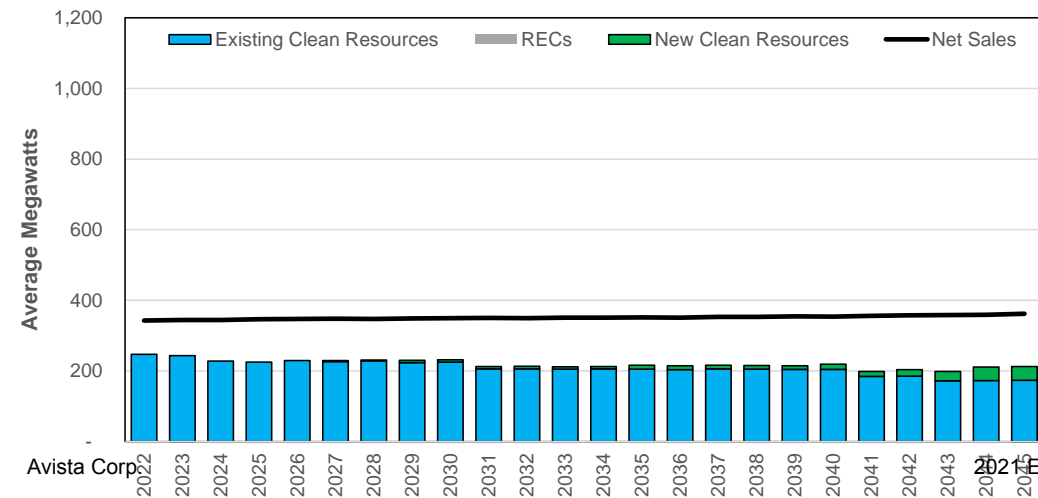

System

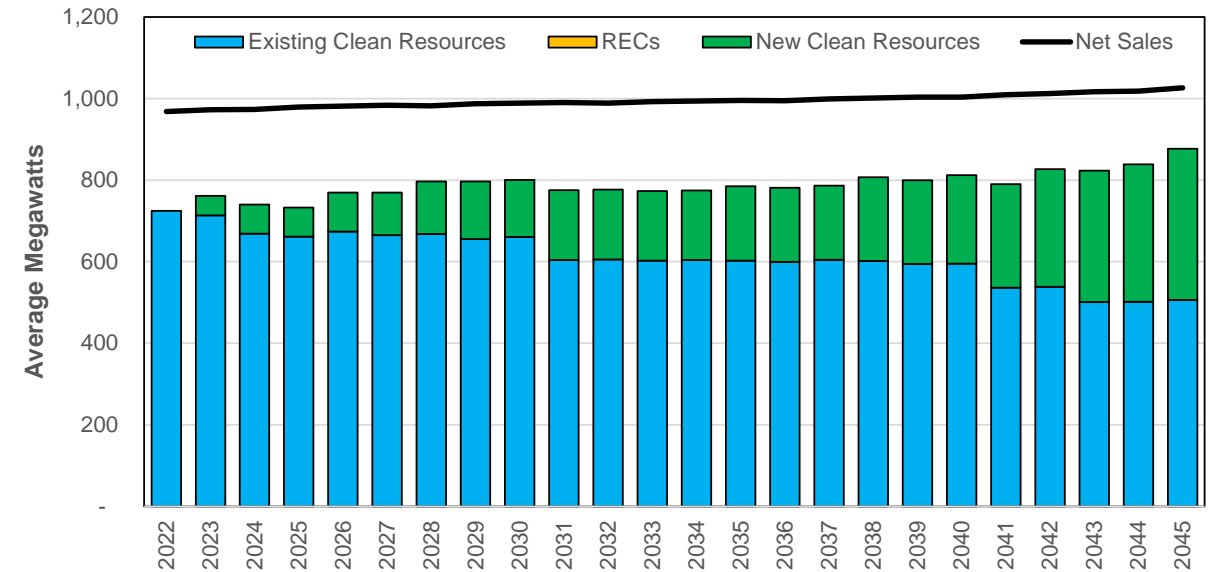

## System Clean Resource Percentage

2022: 74.8%

2027: 78.3%

2045: 85.5%

Excludes Clean Market Purchases



# Annual Average Least Reasonable Cost Rate Forecast

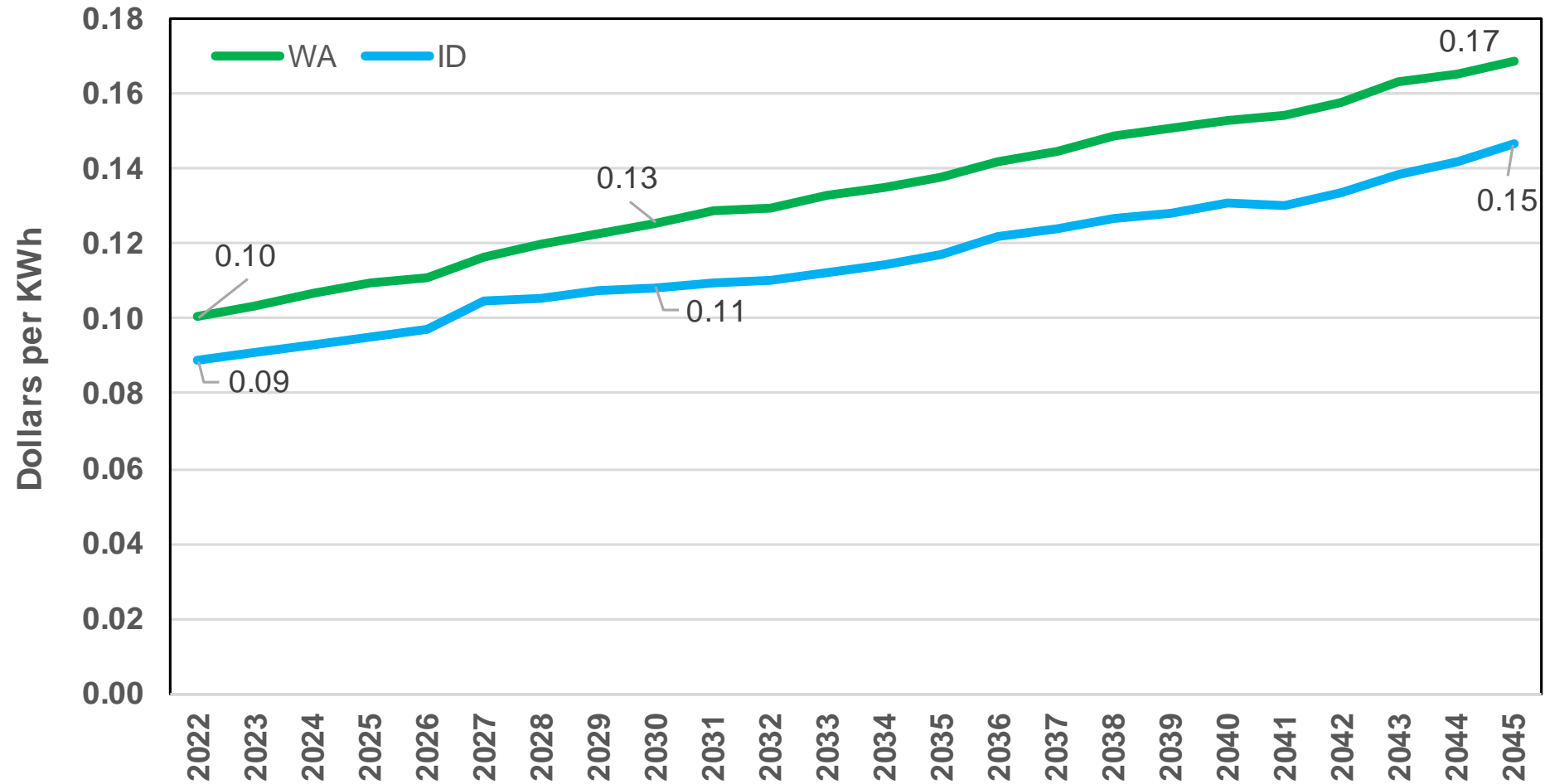

NOTE: Estimated rates only using 2% annual rate increase for non-modeled costs

# Greenhouse Gas Forecast

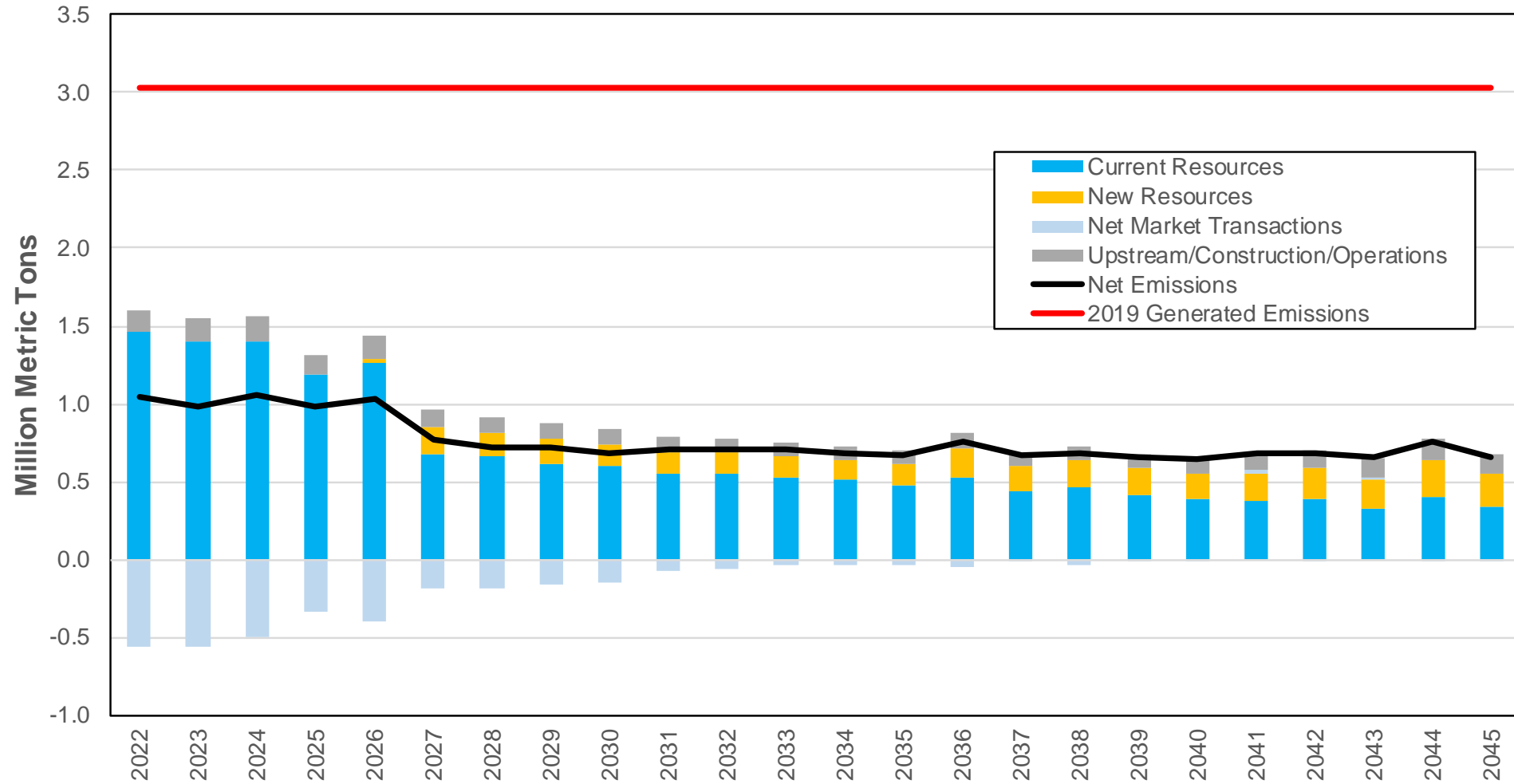

Note: Assumes Colstrip exits the portfolio

2021 Electric IRP Appendices



# Baseline Analysis

1. **Least Reasonable Cost Strategy:** Includes all requirements
2. **Baseline Portfolio 1:** Excludes CETA's 2030 and 2045 goals
  - Used for incremental cost calculation
3. **Baseline Portfolio 2:** Baseline Portfolio 1 + removal of SCC
  - Energy Efficiency held constant from LCS
  - Used to estimate cost of capacity by comparing to Baseline 3
4. **Baseline Portfolio 3:** Baseline Portfolio 2 + removal of capacity constraints
  - Estimates cost to serve load without new resources

# Resource Mix Summary

	1. LRCS	2. Baseline 1	3. Baseline 2	4. Baseline 3
<b>Shared System Resource</b>				
NG CT	132	132	479	0
Solar	300	150	150	0
Storage Added to Solar	300	150	150	0
Wind	0	0	0	0
Storage	0	33	0	0
Hydrogen	0	0	0	0
Other- (Clean Capacity)	0	0	0	0
Thermal Upgrade	17	17	17	0
Hydro	0	0	75	0
<b>Washington</b>				
NG CT	0	84	0	0
Solar	250	0	0	0
Storage Added to Solar	50	0	0	0
Wind	400	0	0	0
Storage	0	30	0	0
Hydrogen	50	100	0	0
Other- (Clean Capacity)	0	0	0	0
Thermal Upgrade	0	0	0	0
Hydro	75	75	0	0
DR Capability	56	55	35	3
EE- Winter Capacity	88	86	88	88
EE- Summer Capacity	101	94	101	101
<b>Idaho</b>				
NG CT	139	139	0	0
Solar	50	0	50	0
Storage Added to Solar	50	0	50	0
Wind	0	0	0	0
Storage	30	90	80	0
Hydrogen	0	0	0	0
Other- (Clean Capacity)	0	0	0	0
Thermal Upgrade	0	0	0	0
Hydro	0	0	0	0
DR Capability	8	19	19	2
EE- Winter Capacity	24	23	24	24
EE- Summer Capacity	13	13	13	13

# Cost Comparison of Baseline Scenarios

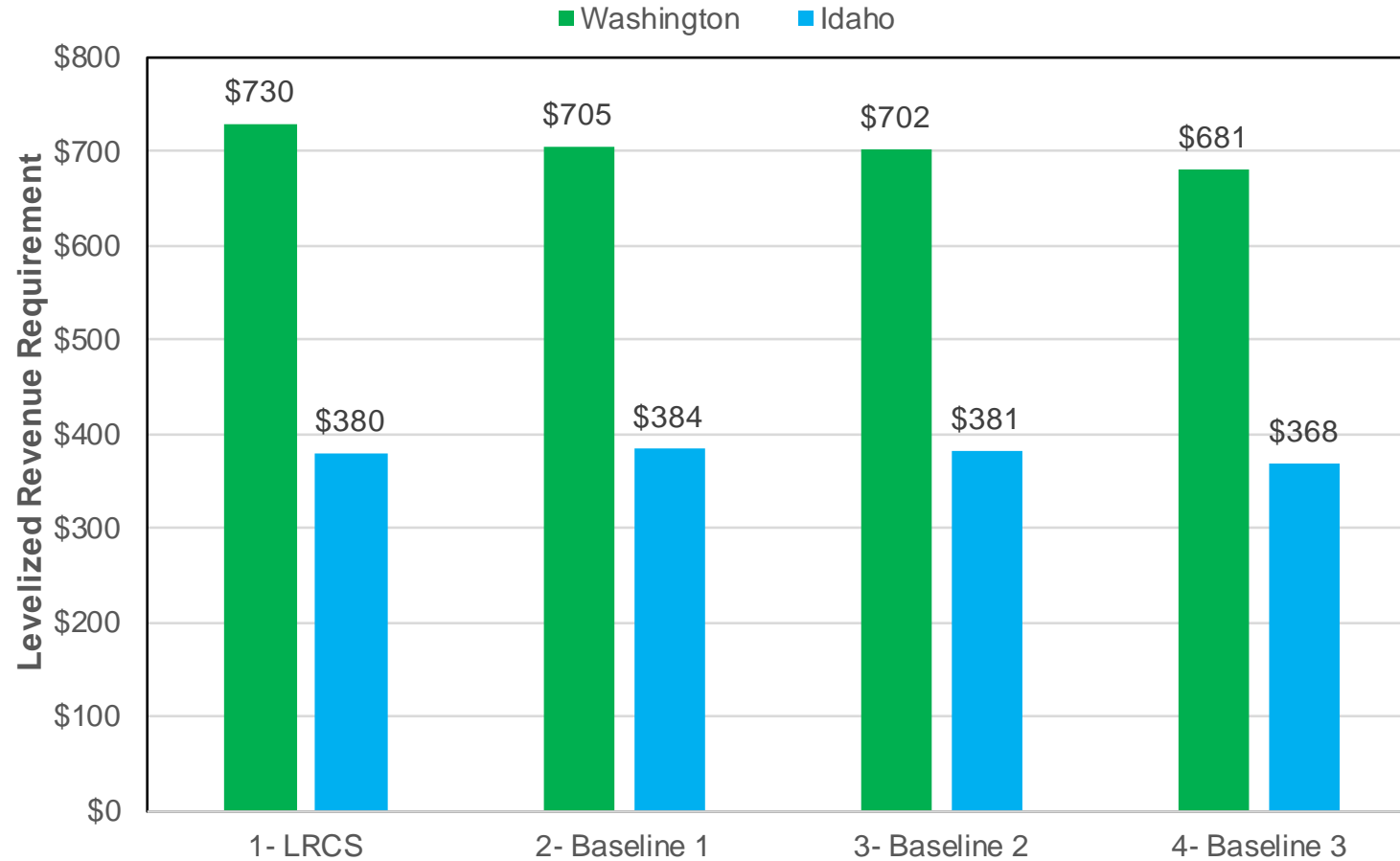

Cost difference is cost of clean energy targets



Cost difference is cost of clean energy targets & SCC (excludes EE)



Cost difference is cost of capacity (excludes EE)



# Washington CETA Cost Cap Analysis (assumes current methodology)

Washington Incremental Cost Calculation	2022	2023	2024	2025
Revenue Requirement w/ SCC	651	669	693	698
Baseline (Total Revenue Requirement Plus SCC)	649	657	670	675
Annual Delta	2	12	23	23
Percent Change	0%	2%	3%	3%
Four Year Max Spending				118.4
Annual Max Spending	29.6	29.6	29.6	29.6
Forecasted Spend				59

Forecasted to be under cap (59)

Incremental cost

Annual spending to use cap

Washington Incremental Cost Calculation	2026	2027	2028	2029	2030	2031	2032	2033	2034	2035	2036	2037	2038	2039	2040	2041	2042	2043	2044	2045
Revenue Requirement w/ SCC	718	715	735	749	763	775	782	797	810	825	855	861	889	900	914	925	951	984	1,013	1,030
Baseline (Total Revenue Requirement Plus SCC)	685	702	713	725	735	754	759	775	786	798	829	834	868	877	887	888	912	936	986	996
Annual Delta	33	13	22	23	28	22	23	22	24	28	25	27	21	23	27	37	39	48	27	34
Percent Change	5%	2%	3%	3%	4%	3%	3%	3%	3%	3%	3%	3%	2%	3%	3%	4%	4%	5%	3%	3%
Four Year Max Spending				127.9				136.8				146.0				158.5			113.2	
Annual Max Spending	32.0	32.0	32.0	32.0	34.2	34.2	34.2	34.2	36.5	36.5	36.5	36.5	39.6	39.6	39.6	39.6	37.7	37.7	37.7	
Forecasted Spend				91				94				104				108			113	
				(37)				(43)				(42)				(50)			0	

Increases exceed 2% each year over baseline, but rate cap is exponential.

Avista should hit 2042-44 rate cap.

# New Supply-Side Resource Avoided Costs

Year	Flat (\$/MWh)	On-Peak (\$/MWh)	Off-Peak (\$/MWh)	Clean Energy Premium (\$/MWh)	Capacity Premium (\$/kW-Yr)
2022	\$20.37	\$21.67	\$18.63	\$0.00	\$0.00
2023	\$18.70	\$19.22	\$18.01	\$17.32	\$0.00
2024	\$18.73	\$19.04	\$18.32	\$17.66	\$0.00
2025	\$20.00	\$20.05	\$19.92	\$18.02	\$0.00
2026	\$23.74	\$23.68	\$23.83	\$18.38	\$0.00
2027	\$24.65	\$24.27	\$25.16	\$18.75	\$82.67
2028	\$25.69	\$24.87	\$26.79	\$19.12	\$84.32
2029	\$26.66	\$25.77	\$27.85	\$19.50	\$86.01
2030	\$26.46	\$25.48	\$27.80	\$19.89	\$87.73
2031	\$27.63	\$26.48	\$29.19	\$20.29	\$89.49
2032	\$28.02	\$26.86	\$29.58	\$20.70	\$91.28
2033	\$29.30	\$27.94	\$31.16	\$21.11	\$93.10
2034	\$29.46	\$27.85	\$31.65	\$21.53	\$94.96
2035	\$30.48	\$28.82	\$32.71	\$21.96	\$96.86
2036	\$32.10	\$30.38	\$34.43	\$22.40	\$98.80
2037	\$31.95	\$30.08	\$34.48	\$22.85	\$100.78
2038	\$34.46	\$32.26	\$37.45	\$23.31	\$102.79
2039	\$34.77	\$32.28	\$38.13	\$23.77	\$104.85
2040	\$35.70	\$32.94	\$39.40	\$24.25	\$106.94
2041	\$38.23	\$35.77	\$41.56	\$24.74	\$109.08
2042	\$38.72	\$36.41	\$41.84	\$25.23	\$111.26
2043	\$39.27	\$36.92	\$42.44	\$25.73	\$113.49
2044	\$46.82	\$44.10	\$50.49	\$26.25	\$115.76
2045	\$46.48	\$44.00	\$49.80	\$26.77	\$118.07
<b>20 yr Levelized</b>	<b>\$25.86</b>	<b>\$25.18</b>	<b>\$26.78</b>	<b>\$25.27</b>	<b>\$57.64</b>
<b>24 yr Levelized</b>	<b>\$27.18</b>	<b>\$26.36</b>	<b>\$28.30</b>	<b>\$25.33</b>	<b>\$62.15</b>

2024 Electric IR Appendix



# Least “Reasonable” Cost Strategy & Baseline Analysis

## “Not Preferred Resource Strategy Yet”

James Gall, Electric IRP Manager  
Fourth Technical Advisory Committee Meeting  
November 17, 2020



# Safe Harbor Statement

This document contains forward-looking statements. Such statements are subject to a variety of risks, uncertainties and other factors, most of which are beyond the Company's control, and many of which could have a significant impact on the Company's operations, results of operations and financial condition, and could cause actual results to differ materially from those anticipated.

For a further discussion of these factors and other important factors, please refer to the Company's reports filed with the Securities and Exchange Commission. The forward-looking statements contained in this document speak only as of the date hereof. The Company undertakes no obligation to update any forward-looking statement or statements to reflect events or circumstances that occur after the date on which such statement is made or to reflect the occurrence of unanticipated events. New risks, uncertainties and other factors emerge from time to time, and it is not possible for management to predict all of such factors, nor can it assess the impact of each such factor on the Company's business or the extent to which any such factor, or combination of factors, may cause actual results to differ materially from those contained in any forward-looking statement.

# Portfolio Scenarios- 2021 IRP

1. Preferred Resource Strategy
2. Baseline Portfolio 1 (No CETA renewable targets)
3. Baseline Portfolio 2 (No CETA renewable targets/SCC)
4. Baseline Portfolio 3 (No additions)
5. Clean Resource Plan (100% Portfolio net clean by 2027)
6. Clean Resource Plan (100% Portfolio clean by 2045)
7. Social Cost of Carbon applied to Idaho
8. Least Cost Plan- w/ low load growth
9. Least Cost Plan- w/ high load growth
10. Least Cost Plan- w/ Northwest Resource Adequacy Market Peak Credits
11. Heating Electrification Scenario 1
12. Heating Electrification Scenario 2
13. Heating Electrification Scenario 3
14. Least Cost Plan- w/ climate shift
15. Least Cost Plan- w/ 2x SCC prices
16. Colstrip serves Idaho customers through 2025
17. Colstrip serves Idaho customers through 2035
18. Colstrip serves Idaho customers through 2045
19. If necessary: CETA deliver to customers each hour
20. Social Cost of Carbon "Tax" Least Cost Strategy
21. If necessary: other resource specific scenarios depending on outcome of PRS results

Only black font scenarios are shown in this presentation

# Scenario Descriptions

1. **Least Reasonable Cost Strategy:** Includes all requirements
2. **Baseline Portfolio 1:** Excludes CETA's 2030 and 2045 goals
  - Used for incremental cost calculation
3. **Baseline Portfolio 2:** Baseline Portfolio 1 + removal of SCC
  - Energy Efficiency held constant from LCS
4. **Baseline Portfolio 3:** Baseline Portfolio 2 + removal of capacity constraints
  - Energy Efficiency held constant from LCS
5. **Clean Resource Plan (2027)**
  - Add constraint to meet or exceed 100% of all retail sales with clean energy
6. **Clean Resource Plan (2045)**
  - Add constraint to meet or exceed 100% of all retail sales with clean energy
  - All thermal resources must exit by 2044
  - No new thermal resources
7. **Social Cost of Carbon applied to Idaho**
  - Includes SCC as cost adder to generation and savings for EE using same method as

# Scenario Descriptions Continued

- 15. Least Cost Plan- with 2 time SCC prices**
  - Double of Social Cost of Carbon charge for Washington Only
- 16. Colstrip serves Idaho customers through 2025**
  - Colstrip obligated to run through 2025 in both states
- 17. Colstrip serves Idaho customers through 2035**
  - Colstrip obligated to run though 2035 for Idaho
- 18. Colstrip serves Idaho customers through 2045**
  - Colstrip obligated to run through 2045 for Idaho

# Portfolio Sensitivities

- Portfolio scenarios will be tested with alternative price forecasts
  - High Natural Gas Prices
  - Low Natural Gas Prices
  - Social Cost of Carbon “Tax”
  - Climate Shift
- Likely available for draft document, but not TAC presentations

# Scenario Cumulative Resource Selection

	1. LRCS	2. Baseline 1	3. Baseline 2	4. Baseline 3	5. CRS (2027)	6. CRS (2045)	7. SCC ID	15- LRCS 2x SCC	16- Colstrip 2025	17- Colstrip 2035	18- Colstrip 2045
<b>Shared System Resource</b>											
NG CT	132	132	479	0	0	0	48	0	132	132	132
Solar	300	150	150	0	650	670	200	100	300	300	300
Storage Added to Solar	300	150	150	0	650	625	200	100	300	300	300
Wind	0	0	0	0	250	550	0	0	0	0	0
Storage	0	33	0	0	0	0	0	0	0	0	0
Hydrogen	0	0	0	0	0	0	0	0	0	0	0
Other- (Clean Capacity)	0	0	0	0	0	20	0	0	0	0	0
Thermal Upgrade	17	17	17	0	17	12	17	17	17	17	17
Hydro	0	0	75	0	0	0	75	0	0	0	0
<b>Washington</b>											
NG CT	0	84	0	0	48	0	84	144	0	0	0
Solar	250	0	0	0	100	0	350	0	250	250	250
Storage Added to Solar	50	0	0	0	0	0	50	0	75	0	0
Wind	400	0	0	0	200	450	400	600	400	400	400
Storage	0	30	0	0	0	250	0	140	0	10	10
Hydrogen	50	100	0	0	50	100	50	100	50	50	50
Other- (Clean Capacity)	0	0	0	0	0	50	0	0	0	0	0
Thermal Upgrade	0	0	0	0	0	0	0	0	0	0	0
Hydro	75	75	0	0	75	75	0	75	75	75	75
DR Capability	56	55	35	3	56	104	56	55	55	57	57
EE- Winter Capacity	88	86	88	88	89	91	90	98	88	91	92
EE- Summer Capacity	101	94	101	101	99	115	116	142	113	100	100
<b>Idaho</b>											
NG CT	139	139	0	0	120	0	84	223	139	139	55
Solar	50	0	50	0	300	585	0	0	0	0	50
Storage Added to Solar	50	0	50	0	125	200	0	0	0	0	50
Wind	0	0	0	0	150	50	0	0	0	0	0
Storage	30	90	80	0	0	0	40	50	90	70	130
Hydrogen	0	0	0	0	0	250	50	50	0	0	0
Other- (Clean Capacity)	0	0	0	0	0	0	0	0	0	0	0
Thermal Upgrade	0	0	0	0	0	0	0	0	0	0	0
Hydro	0	0	0	0	0	0	0	0	0	0	0
DR Capability	8	19	19	2	19	19	21	7	8	17	20
EE- Winter Capacity	24	23	24	24	25	33	39	23	22	21	23
EE- Summer Capacity	13	13	13	13	18	22	36	12	15	11	15

2021 Electric IRP Appendices



# Existing Resource “Exits”

	1- LRCS	2- Baseline 1	3- Baseline 2	4- Baseline 3 w/ EE	5- Clean Resource Plan (2027)	6- Clean Resource Strategy (2045)	7- SCC Idaho	15- 2x SCC	16- Colstrip 2025	17- Colstrip 2035	18- Colstrip 2045
Coyote Springs 2	-	-	-	-	-	2044	-	2022	-	-	-
Lancaster	2026	2026	2026	2026	2026	2026	2026	2026	2026	2026	2026
Colstrip (3)	2021	2021	2021	2021	2021	2035	2021	-	2025	2035	2045
Colstrip (4)	2021	2021	2021	2021	2021	2021	2021	2025	2025	2035	2045
Kettle Falls	-	-	-	-	-	-	-	-	-	-	-
Kettle Falls CT	-	-	-	-	-	2044	-	-	-	-	-
Boulder Park 1-6	2040	2037	2026	2040	2040	2040	2040	2030	2040	2040	2040
Rathdrum 1	-	-	-	-	-	2044	-	-	-	-	-
Rathdrum 2	-	-	-	-	-	2044	-	-	-	-	-
Northeast A&B	2035	2035	2026	2035	2035	2035	2035	2035	2035	2035	2035

**Note:**

Assumes each plant is available through December 31<sup>st</sup> of the final year;

Exception: Lancaster PPA expires Oct 2026.

Dash indicates no plant exit in the study

# 2022-45 Levelized Revenue Requirement

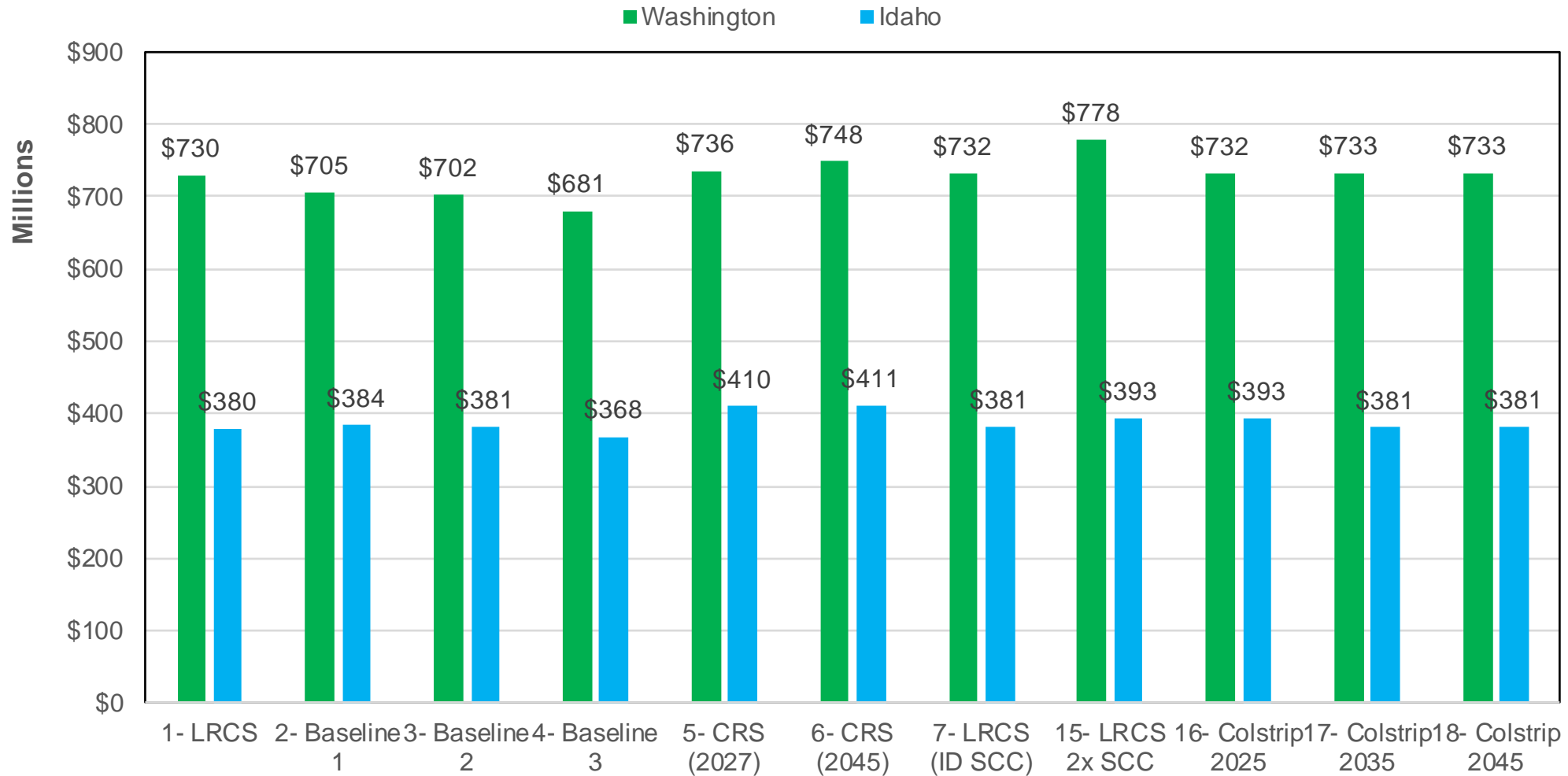



# Rate Estimates (Average Annual)

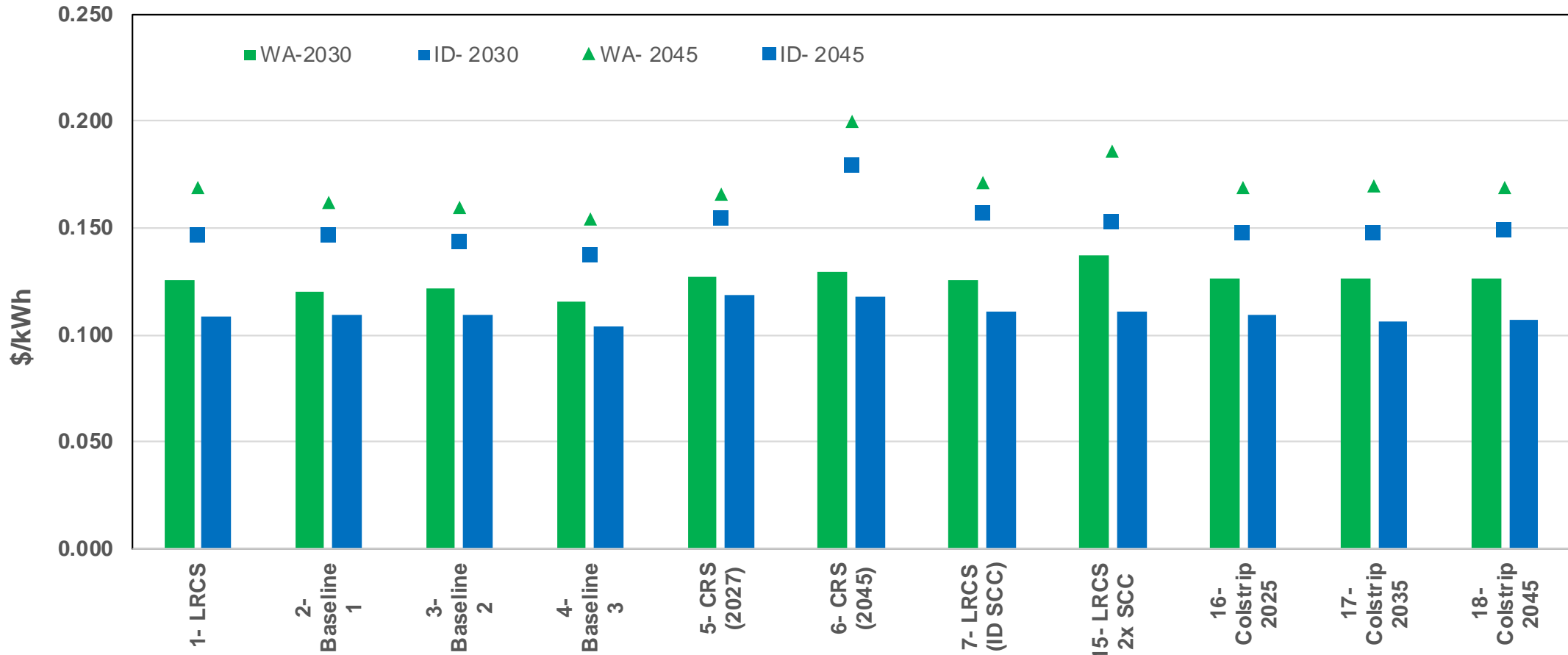

# Annual Greenhouse Gas Emission

## Avista Dispatch & Storage Purchases

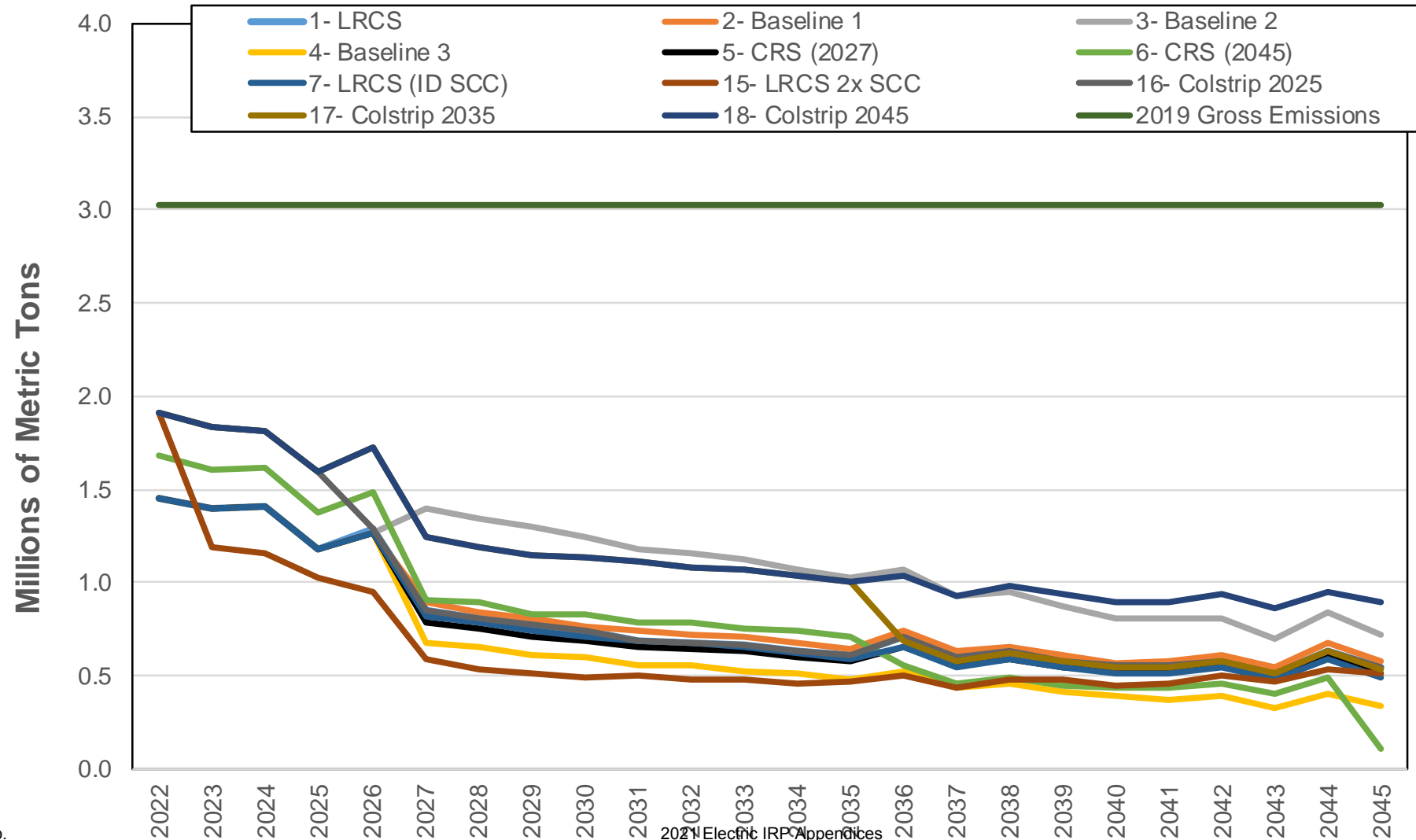

# Cost vs. GHG Tradeoffs

## Change in Levelized Cost vs. Change in Levelized Net Emissions

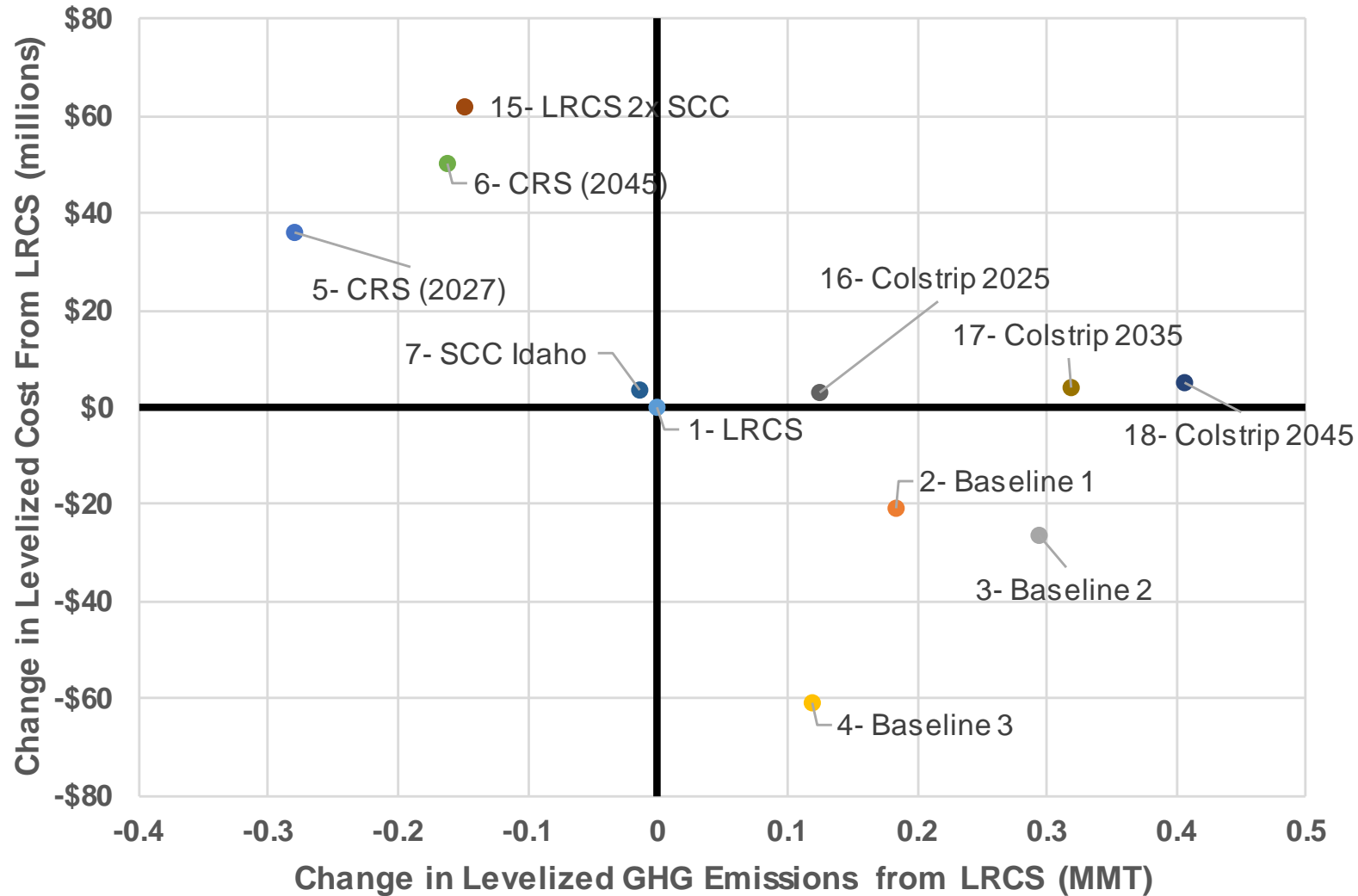

# 2030 Risk Analysis

Measures 2030 standard deviation of “modeled” power cost compared to levelized cost

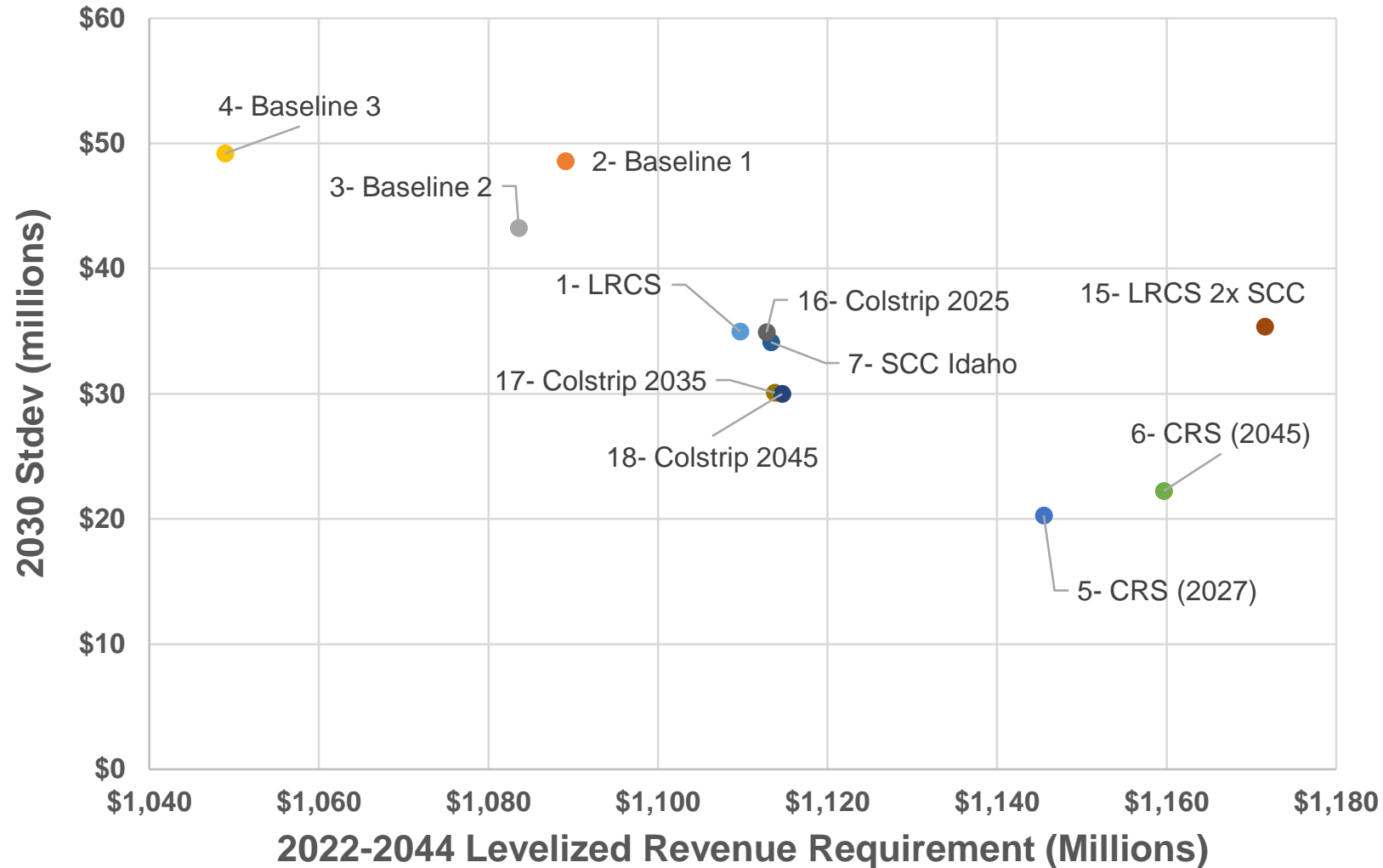

# 2045 Risk Analysis

Measures 2045 standard deviation of “modeled” power cost compared to levelized cost

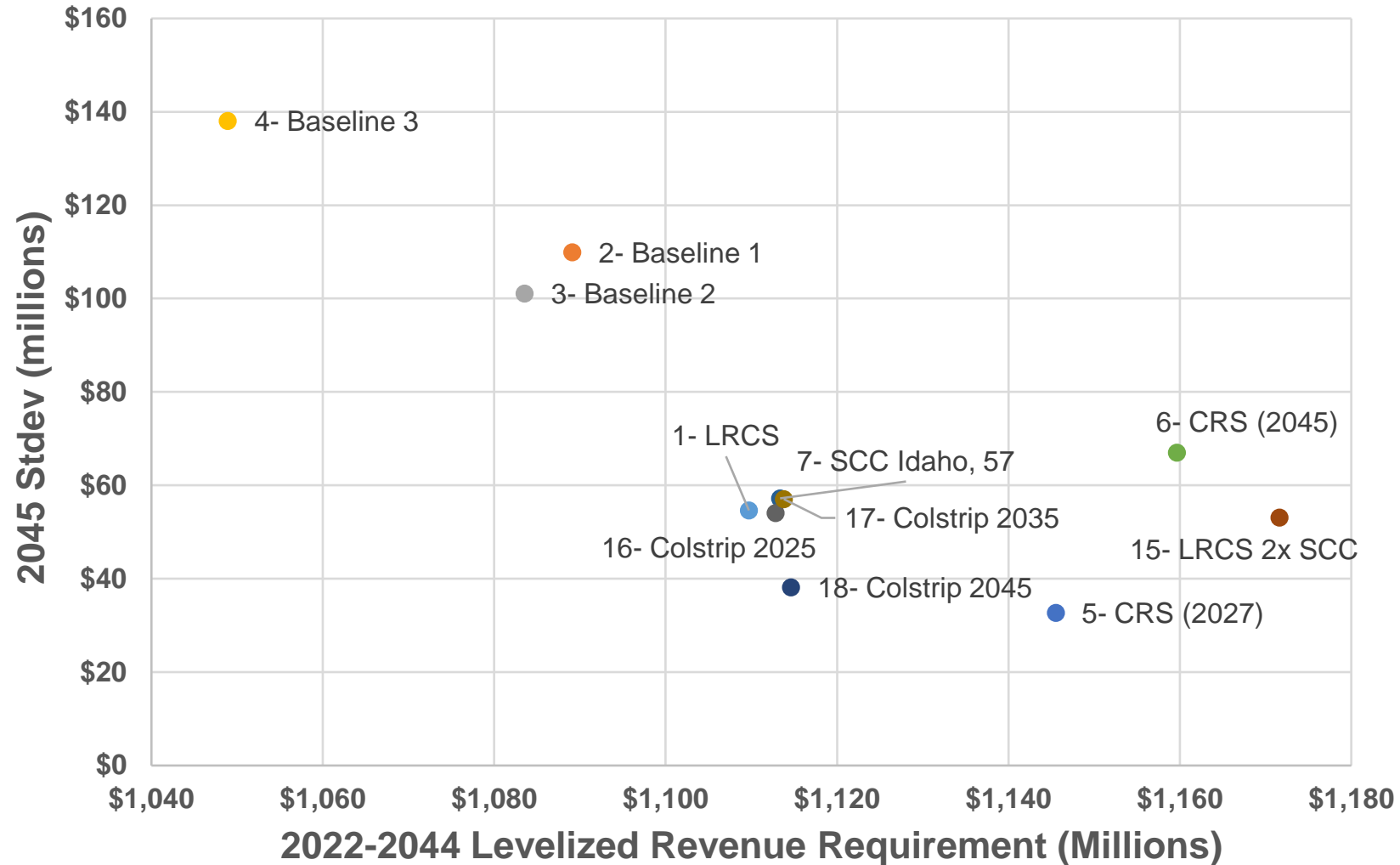

# 2045 Upper Tail Risk Analysis

95<sup>th</sup> percentile power cost minus mean power cost compared to levelized cost

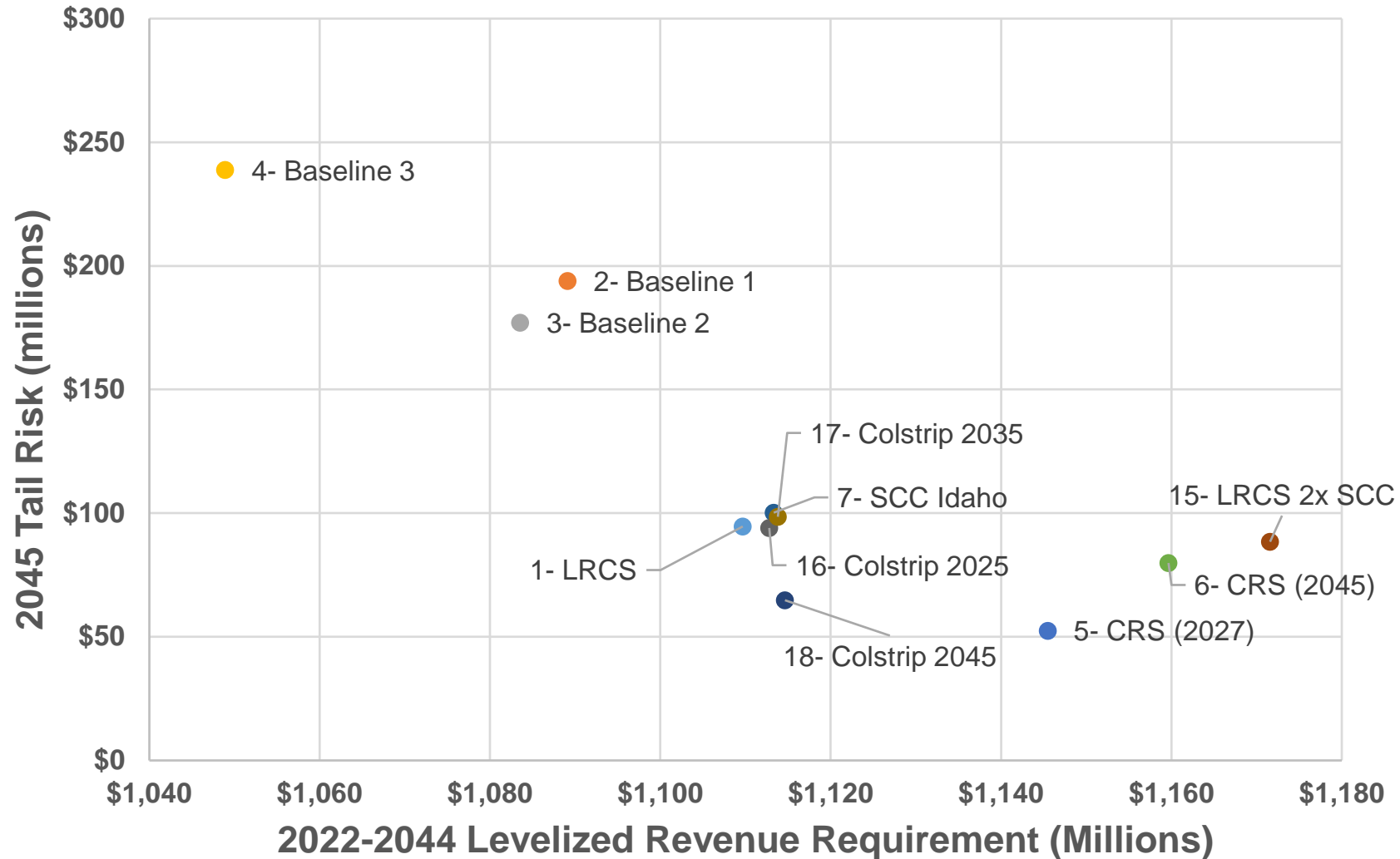

# Next Steps

- Post PRiSM model to website
- Complete other scenarios and sensitivities
- Begin reliability studies
- Update PRiSM model for any modifications
- Select Preferred Resource Strategy
- Re-run scenarios and sensitivities
- Continue reliability studies if necessary

## **2021 Electric IRP TAC 4 Meeting – November 17, 2020**

Annette Brandon, James Gall, Lori Hermanson, John Lyons, Tom Pardee, Chip Estes, Dainee Gibson-Webb (ICL), Dean Kinzer, Jody Morehouse, Kevin Keyt, Annie Gannon, Leona Haley, Clint Kalich, Melissa Kuo (Clearwater), Michael Eldred (IPUC), Mike Louis (IPUC), Rachel Farnsworth (IPUC), Peter Sawicki (Mitsubishi Power), Jennifer Snyder (UTC), Terri Carlock (IPUC), Jan Himebaugh (BIAW), Shay Bauman (PC), Joanna Huang (UTC), Ryan Finesilver, Marissa Warren, Jaime Majure, James McDougal, Joni Bosh (NWECE), Amanda Ghering, George Lynch, Katie Ware, Ian McGetrick, John Chatburn, Amy Wheelless (NWECE), Corey Dahl (Public Counsel), Jorgen Rasmussen, Jared Hansen, Garrett Brown, Pat Ehrbar, Charlie Inman (PSE), Steve Johnson (UTC), Terrance Brown, Jared Hansen (IPUC), Chris Drake, Scott Kinney, Jason Thackston, Darrell Soyars, Sean Bonfield, Thomas Dempsey, Jeff Schlect, Ben Otto (ICL), Meghan Pinch, Grant Forsyth, Tina Jayaweera, and Tomas Morrissey (PNUCC).

Any notes in italics are short response from the presenter for each topic.

### **Introductions, John Lyons**

No questions

### **Final Resource Needs Assessment (formerly L&R), John Lyons**

**Steve Johnson:** Are Colstrip and Lancaster the deficits in 2026/27?

**James Gall:** The loss of Colstrip for 220 MW and Lancaster for 222 MW are the two major changes from the 2025-2027 period.

### **2020 Renewable RFP Update, Chris Drake**

**Steve Johnson:** Under proposed CR103 for IRP planning with CETA requirements, if the deficit is within 4 years you will need an RFP. I notice your capacity need is just over 4 years out. Do you anticipate issuing another RFP after this one?

**James Gall:** The resource strategy may call for resources ahead of need or it may call for a renewable or non-capacity need. If this RFP can satisfy those needs that could push this earlier resource shortage further out. If there's still a need after this RFP is complete, we'll need to do an RFP in the next year or so since it will be close to that 4-year window if something new needs to be built.

**Steve Johnson (Slide 5):** I'm concerned with that being late given the general region is also needing resources around this date and we will be in a capacity crunch. We're waiting, but that could pose a problem with coal retirements and everyone else being in



the same boat at the same time. Rather, could you smooth purchases out ahead of time as opposed to buying just before the need?

**James Gall:** You have the same concerns we do.

**Jason Thackston:** Can't time these perfectly. We need to ensure reliability which guides the timing to early rather than to later acquisition while trying to balance affordability, etc.

### **Portfolio Modeling Overview, James Gall**

**Ben Otto via chat:** Avista – can you send out a copy of this portion of the presentation materials? Thank you. *An email was just sent with the updated slide decks.* Thanks John and Lori. The PRiSM slides are the ones I was looking for.

**James Gall:** It will be sent out shortly to the entire TAC.

**Peter Sawicki:** How do you look at new technology such as renewable hydrogen?

**James Gall:** The list of resources included in our model, forecast of costs, and forecast of how costs change are all on our website and are out there for input from the TAC. Two renewable hydrogen options were included.

**Mike Louis:** Quite a bit of additional functionality that you're building into PRiSM, what steps are you taking for validation of that model?

**James Gall:** How would you define validation?

**Mike Louis:** How well does the model represent operations and how well is the model producing something that represents reality.

**James Gall:** That is the benefit of building the model in Excel. It is easy to audit and how it works is transparent. You can see the L&R balances, if the costs are reasonable, and it is reviewed by internal and external folks to make sure the model is producing a result based on the math we intended. There may be some disagreement with assumptions for inputs, but you can review the math. For operations, we are not proposing any changes to our operations based on PRiSM modeling. This is a financial exercise to determine who pays for resources in the future as opposed to how we currently allocate resources.

**Mike Louis:** That helps a lot James. At the end of the day with my experience in modeling, I'd like to see a validation plan to ensure validity for all the tests and the results to see if they are reasonable. I'd like to see a comprehensive plan of how you thought of this ahead of time and how you tested it.

**James Gall:** We'll talk about a lot of these tests this afternoon. The scenarios test the validity of the model a lot.

**Steve Johnson:** Is this the model you'd use if you were examining DR in a single source context? Would you still use this model?

**James Gall:** No, this is a planning tool. If you were choosing what to acquire, we'd use something else – a more granular model. You could use this model for capacity value, etc. You could put in resource options from an RFP to see what it'd pick, but it might be better to use a more granular tool.

**Steve Jonson:** This model is enough to give you some value such as capacity value?

**James Gall:** Yes, it gives you the financial value, but not the reliability value. Operational value and reliability value, you could put all of that into this tool and let it pick your options. If you have a large amount of choices that are vastly different, this tool would work; if the choices are more similar, you'd probably want a different tool.

**Michael Eldred:** Does that apply to new resources also?

**James Gall:** New resources are different and can be acquired just for one state or allocated between both states. Operationally, they are the same, but the payments for them could be different.

**Mike Louis:** For Colstrip, are you modeling those units separately?

**James Gall:** Yes, we are modeling Colstrip units with separate capital and O&M costs.

**Ben Otto:** Are you saying there is already a certain amount of efficiency in the load forecast and some can be selected? And what happens if it can choose more than is out there?

**James Gall:** We don't know what energy efficiency is out there so we iterate. We keep rerunning it until the amount selected and the amounts in the CPA are essentially the same. Limits of econometric as opposed to end use forecast.

**Jennifer Snyder:** To make sure I have this correct about end effects for Grant's load forecast, no matter how much cost-effective energy efficiency is selected, it's never going to reduce it?

**James Gall:** It's not going to change significantly. Grant does make assumptions on how customers change their use through the use per customer numbers.

**Grant Forsyth:** I'm on the call. There are specific factors that reduce use per customer and some that can't be explained, but it could be "efficiency". There is some amount of energy efficiency I'm projecting going forward.

**Jennifer Snyder:** Ok, thank you. A follow up on that. How does that dynamic work with DR?

**James Gall:** Good segue to the next slide. We have no historical DR programs [non-pilot size], so DR doesn't affect load for the forecast. DR is treated differently from that point of view. EVs could be a concern.

**Grant Forsyth:** There is nothing explicit for EVs. The load forecast assumed the amount used per year per customer.

**Steve Johnson:** I'm trying to understand what kind of assumptions of cost and value streams you put into your model.

**James Gall:** We assume Mid-C prices and not necessarily the value of selling any beyond what goes into California.

**Steve Johnson:** CPUC regulatory action, that hasn't been taking into account, but maybe taking that into account has an impact on price. Would you put that into your model?

**James Gall:** We value based on our market at the Mid-C, we're only trying to value for intra-hour energy. Other values are outputs based on your choices as compared to energy-only resources.

**Amy Wheelless via chat:** Do you make any assumptions about consumers buying CTA 2045 enabled water heaters due to markets (e.g., someone in the CdA area buying a water heat at a Spokane Lowes)?

**James Gall:** We're not considering that.

**Ben Otto:** How are some results showing a shared system and then some are assigned for each state?

**James Gall:** Let's table that math to this afternoon's discussion.

**Ben Otto:** If you sell RECs and return the revenue to Idaho customers, what about increments of more than 20% being sold to Washington?

**James Gall:** We could show that. I will add it to the list. It would be available renewable energy times the REC price.

**Charlie Inman via chat (slide 15):** For market transactions, the Washington CETA defines the emission rate of "unspecified market purchases" as 0.437 metric tons per MWh. Will this be included at all in the modeling process?

**James Gall:** Not at this time. It is in CETA, but is related to a different use and we're looking at this for the future. That default emissions number is based on a gas turbine. We're including the average market emissions rate for all purchases and storage. We're unable to model general purchases now, but will look at this for the future. There is an opportunity for adjustment.

**Jennifer Snyder:** I don't recall what that is in CETA. *It's in section 7.* I will read it over lunch.

**Steve Johnson:** There is not a lot of time for debating when it comes to the evaluation for transmission. For resources, you aren't including any end-of-life resources past the end of useful life, have you thought that there is an advantage to someone else operating a resource, if it isn't your least cost resource?

**James Gall:** Transmission costs are levelized; even if a resource does go offline, we benefit from the available transmission. There is quite a bit of advantage if someone else operates with all of that transmission interconnection. You've identified a head scratcher of what could happen, but how can you model everything.

### **After lunch**

**Ben Otto:** James, I thought of a question at lunch. What \$/MWh is Avista using for the social cost of carbon? Is it the Washington UTC adopted numbers?

**James Gall:** Ben, the social cost of carbon is the Washington adopted value for CETA. It is available on the website in Excel form by year.

### **Draft PRS and Scenarios, James Gall**

**Steve Johnson:** We are really on a roll now. This raises questions about whatever happened to the idea for super freezing air.

**James Gall:** Liquid air shows up in some scenarios for some options in the future. Hydrogen showed up rather than liquid air due to the resource assumption differences for peak credits. Both are about storage, but fuel replacement as well. Hydrogen assumes no constraints and gets a peak credit; whereas, liquid air has some constraints – while there is an air storage tank, we might not be able to refill it quickly.

**Steve Johnson:** Thanks. That's informative.

**Peter Sawicki:** What does "both" mean?

**James Gall:** Both means the resource serves both states. It serves 65% Washington and 35% Idaho.

**Peter Sawicki:** For the 2029 resource picks, is that additive? *Yes, but we could amend that later.*

**James Gall (slide 16):** DR is cumulative, but the rest of the resources are shown when they show up in the portfolio. DR programs need to start earlier than they are needed to give time to sign customers up for the program.

**Darrell Soyars:** How are transmission costs built in for each resource like in Montana where they would be further away?

**James Gall:** It's complicated, we talked about it briefly earlier today. One avenue is the Colstrip transmission line where we own rights for a little less than 200 MW. Another is NorthWestern Energy transmission which could be a wheel. Other resources could be a wheel request or a capacity build out.

**Ben Otto:** You said some amount of the gas [generation] is driven by capacity needs. What is the amount of hours? Is this a capacity shortfall for a few hours or for several months? What can we see?

**James Gall:** We looked at 1-hour, multiple hours, etc. When we calculate peak credits, we run that through an 8760 to get the 5% LOLP. We need resources with long duration winter generation capability to make sure we have resource adequacy. There are several hours and they are definitely in the November to February period and during hours 14 - 18, but I can't tell you the exact hours. It's difficult to have a resource adequate system.

**Jennifer Snyder:** I'm wondering at the avoided cost in 2022 if on-peak is cheaper than off-peak, or does it switch partway down.

**James Gall:** If I'm remembering correctly from the last TAC meeting, the amount of solar added to the entire system in California, Oregon, Nevada, Arizona and other spots in the west; the new solar is likely to drive prices in the middle of the day to zero or negative prices.

**Steve Johnson:** I have a question or recommendation. Is it possible to add the rate of return adders to PPAs after the modeling analysis?

**James Gall:** Yes, it's possible. I think I've heard of 3 to 4 more scenarios today and I already have 20 more. It can be done, but not sure if they will be done in time to file this IRP. It depends on whether we'll have time to fit these all in

**Steve Johnson:** It might be better to have a portfolio as bid by bidders less the rate of return adders so we can compare the two.

**James Gall:** It won't change the result much, but it will change the avoided cost

**Amy Wheeless:** Can you remind me of the timeline for next steps?

**James Gall:** The next meeting is in two to three weeks. We are using the PRS resources in the current model. There will be a draft IRP out on January 4<sup>th</sup>. We are hoping to include new resources if the 2020 Renewable RFP contracts are signed in time for the draft release in January, but we may need to modify a lot by then.



# Draft 2021 Preferred Resource Strategy

James Gall, Electric IRP Manager  
Technical Advisory Committee Update Meeting  
December 16, 2020

# Safe Harbor Statement

This document contains forward-looking statements. Such statements are subject to a variety of risks, uncertainties and other factors, most of which are beyond the Company's control, and many of which could have a significant impact on the Company's operations, results of operations and financial condition, and could cause actual results to differ materially from those anticipated.

For a further discussion of these factors and other important factors, please refer to the Company's reports filed with the Securities and Exchange Commission. The forward-looking statements contained in this document speak only as of the date hereof. The Company undertakes no obligation to update any forward-looking statement or statements to reflect events or circumstances that occur after the date on which such statement is made or to reflect the occurrence of unanticipated events. New risks, uncertainties and other factors emerge from time to time, and it is not possible for management to predict all of such factors, nor can it assess the impact of each such factor on the Company's business or the extent to which any such factor, or combination of factors, may cause actual results to differ materially from those contained in any forward-looking statement.

# Other Caveats

- Clean Energy Transformation Act (CETA) rules and requirements are not complete.
  - This draft PRS uses Avista’s best estimate of known requirements.
- Avista is negotiating with the 2020 renewable Request for Proposals (RFP) shortlist bidders
  - This may change the results of the resource if a contract is signed.
- IRP resource options are primarily “new” resource options- RFP will determine whether or not existing resources can be acquired at similar or lower cost than “new” options.
- Avista may not be able to physically retire or exit certain resources as the IRP PRiSM model determines because of contract limitations.
- No future state specific resource cost allocation agreement has been made.
- Forward looking rates include non-modeled power supply cost escalating at 2% per year-
  - **DO NOT TAKE THIS AS A RATE FORECAST**
  - This is for informational purposes only



# Cumulative Energy Efficiency End Use Results (GWh)

	2023		2031		2045	
	WA	ID	WA	ID	WA	ID
Appliances	0.3	0.1	3.5	0.8	11.6	2.7
Cooling	5.6	0.5	36.8	3.2	53.1	9.1
Electronics	1.1	0.2	14.1	4.8	25.2	9.3
Exterior Lighting	4.1	1.4	24.1	7.8	36.3	14.3
Food Preparation	0.1	0.0	2.2	0.4	5.9	0.9
Interior Lighting	20.3	13.0	100.1	49.3	171.1	89.6
Miscellaneous	1.3	0.3	11.2	2.8	22.9	5.5
Motors	4.9	3.9	35.3	25.6	41.3	28.8
Office Equipment	0.6	0.0	3.3	0.0	5.8	0.0
Process	0.7	0.1	4.1	1.1	4.5	1.4
Refrigeration	8.2	0.3	60.2	2.3	69.4	2.6
Space Heating	12.6	3.6	120.3	30.8	171.1	40.6
Ventilation	5.1	0.7	29.8	5.2	44.8	12.5
Water Heating	4.3	1.5	62.8	8.6	114.2	10.6
<b>Total</b>	<b>69.2</b>	<b>25.6</b>	<b>507.8</b>	<b>142.9</b>	<b>777.1</b>	<b>227.8</b>

# Cumulative Energy Efficiency Segment Results (GWh)

	2023		2031		2045	
	WA	ID	WA	ID	WA	ID
College	2.1	0.7	11.0	4.2	15.5	7.5
Grocery	6.8	0.2	47.4	1.4	56.3	1.7
Health	2.7	0.9	14.3	5.1	22.8	10.3
Industrial	12.0	8.4	62.5	42.8	91.4	62.9
Large Office	6.5	1.3	43.1	8.8	66.8	16.4
Lodging	1.3	0.6	8.6	2.9	12.5	4.9
Low Income	3.0	1.8	37.3	10.8	53.7	13.5
Miscellaneous	5.1	1.9	35.6	10.7	54.5	19.1
Mobile Home	0.6	0.2	5.5	1.5	8.7	2.3
Multi-Family	0.4	0.2	7.5	1.3	16.3	2.2
Restaurant	2.1	0.2	14.9	1.6	19.8	2.3
Retail	5.6	2.0	35.7	10.3	52.7	17.9
School	2.6	0.1	16.6	0.4	26.5	0.8
Single Family	13.8	5.1	139.6	29.1	234.2	43.7
Small Office	2.2	1.1	16.1	7.4	25.1	13.5
Warehouse	2.3	0.9	12.1	4.7	20.2	8.9
<b>Total</b>	<b>69.2</b>	<b>25.6</b>	<b>507.8</b>	<b>142.9</b>	<b>777.1</b>	<b>227.8</b>

# Higher Washington Energy Efficiency Goals

## More Aggressive Ramp Rates & Higher Avoided Costs

Biennial Conservation Target (MWh)	Based on 2021 IRP	Based on 2020 IRP
CPA Pro-Rata Share	101,566	72,338
Distribution & Street Light Efficiency	219	504
EIA Target	101,785	72,842
Decoupling Threshold	5,119	3,642
Total Utility Conservation Goal	106,904	76,484
Excluded Programs (NEEA)	-12,896	-14,016
Utility Specific Conservation Goal	94,008	62,468
Decoupling Threshold	-5,119	-3,642
EIA Penalty Threshold	88,889	58,826

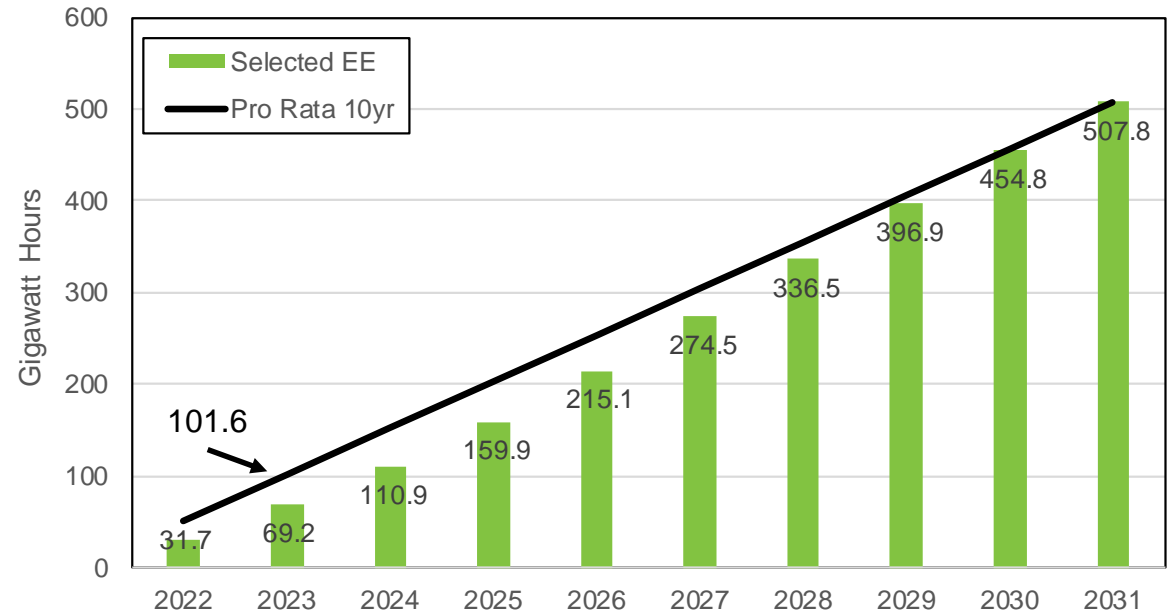

# 24-yr Levelized Avoided Cost for Energy Efficiency

## Washington

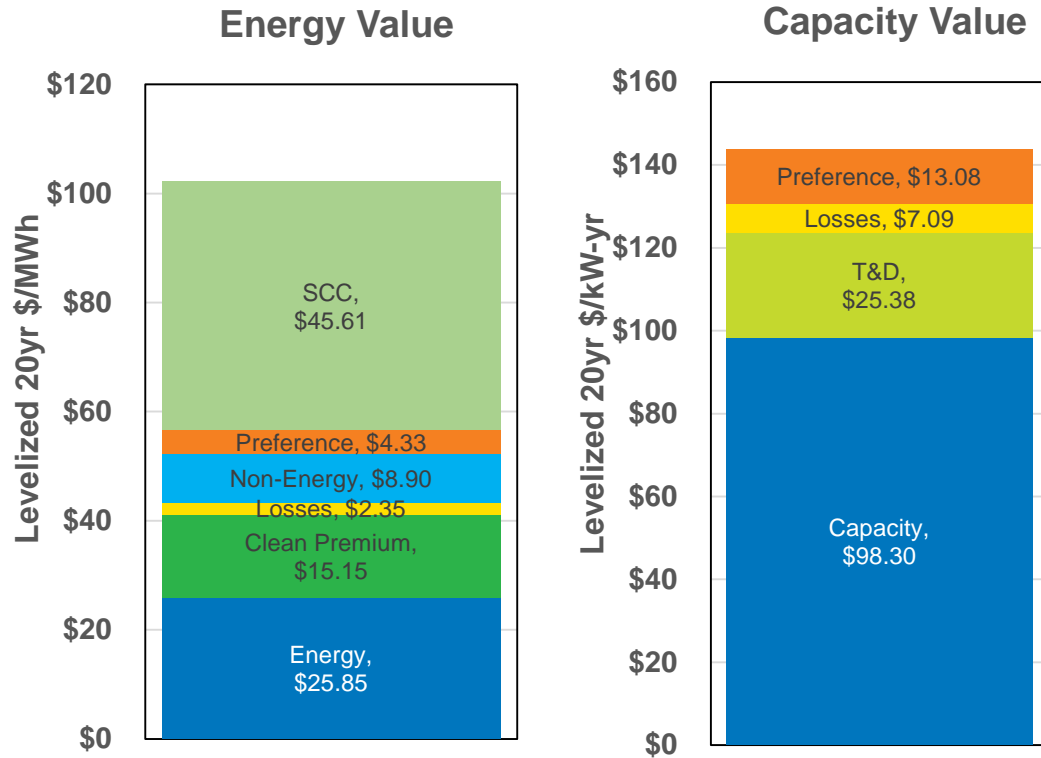

## Idaho

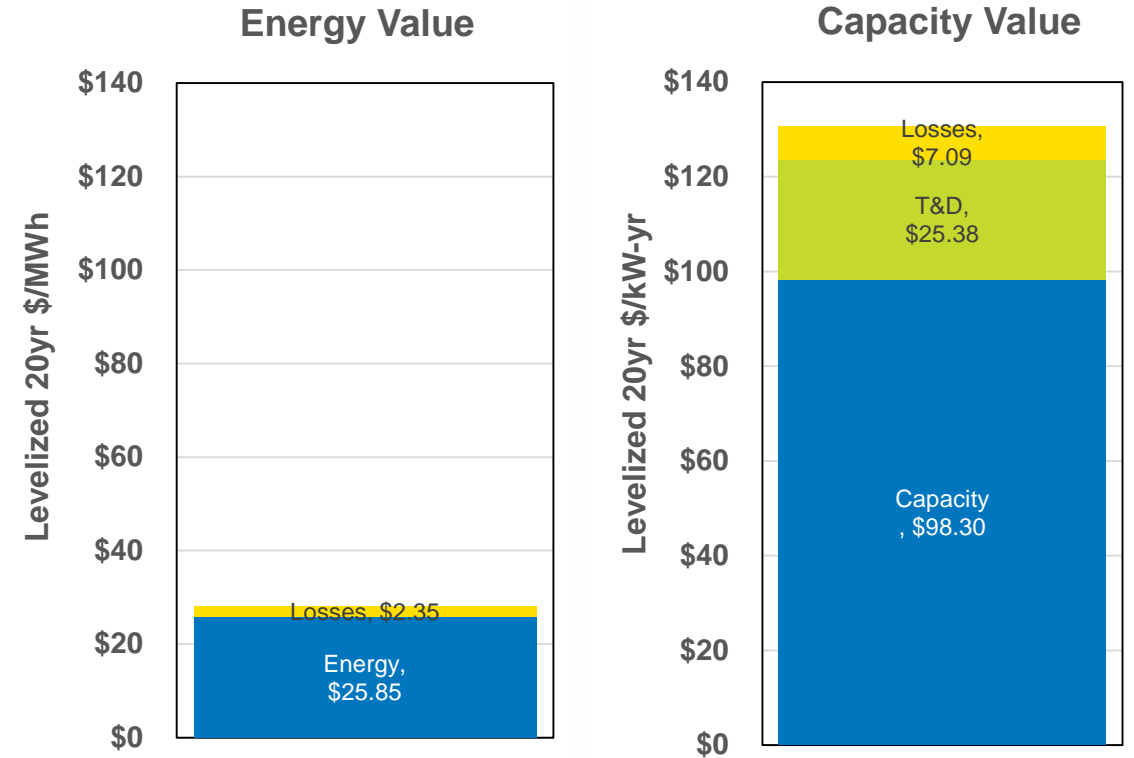

# Winter (January) Capacity Position (MW)

Item	2022	2023	2024	2025	2026	2027	2028	2029	2030	2031	2032	2033	2034	2035	2036	2037	2038	2039	2040	2041
Baseline Load Forecast	1,719	1,725	1,729	1,733	1,738	1,742	1,746	1,751	1,756	1,761	1,766	1,771	1,777	1,783	1,789	1,796	1,804	1,812	1,821	1,830
Embedded EE (added back)	5	11	18	26	35	45	56	66	76	84	91	96	100	104	107	109	111	112	114	115
Load Forecast w/o EE	1,724	1,736	1,747	1,759	1,773	1,787	1,802	1,817	1,832	1,845	1,857	1,867	1,877	1,887	1,896	1,905	1,915	1,924	1,935	1,945
Selected EE	5	11	18	26	35	46	56	67	76	84	91	97	101	105	108	110	112	114	115	116
Colstrip Losses Adjustment	13	13	13	13	13	13	13	13	13	13	13	13	13	13	13	13	13	13	13	13
Other Adjustments	0	0	0	0	0	0	0	0	0	0	0	0	0	0	0	0	0	0	0	0
<b>New Load Estimate</b>	<b>1,706</b>	<b>1,712</b>	<b>1,716</b>	<b>1,720</b>	<b>1,725</b>	<b>1,729</b>	<b>1,733</b>	<b>1,738</b>	<b>1,743</b>	<b>1,748</b>	<b>1,753</b>	<b>1,758</b>	<b>1,764</b>	<b>1,770</b>	<b>1,775</b>	<b>1,782</b>	<b>1,790</b>	<b>1,798</b>	<b>1,807</b>	<b>1,816</b>
Planning Margin	273	274	275	275	276	277	277	278	279	280	280	281	282	283	284	285	286	288	289	291
Reserves + Regulation	137	137	136	136	136	137	137	137	137	138	138	138	139	139	139	140	140	141	141	138
Oper. Reserves Hydro Credit	-17	-17	-13	-13	-13	-13	-12	-12	-12	-8	-8	-8	-8	-7	-7	-7	-7	-7	-7	-7
<b>Net Requirement</b>	<b>2,099</b>	<b>2,106</b>	<b>2,114</b>	<b>2,119</b>	<b>2,125</b>	<b>2,130</b>	<b>2,135</b>	<b>2,141</b>	<b>2,147</b>	<b>2,158</b>	<b>2,164</b>	<b>2,170</b>	<b>2,177</b>	<b>2,184</b>	<b>2,192</b>	<b>2,200</b>	<b>2,210</b>	<b>2,220</b>	<b>2,231</b>	<b>2,238</b>
Long Term Sales	-101	-101	0	0	0	0	0	0	0	0	0	0	0	0	0	0	0	0	0	0
Long Term Purchases	0	0	0	0	0	0	0	0	0	0	0	0	0	0	0	0	0	0	0	0
Clark Fork River	798	798	798	798	798	798	798	798	798	798	798	798	798	798	798	798	798	798	798	798
Spokane River	163	163	163	153	165	165	165	165	165	165	165	165	165	165	165	165	165	165	165	165
Mid-Columbia Contracts	228	227	147	146	145	144	142	135	135	63	63	64	64	64	64	64	64	64	64	64
PURPA Contracts	78	78	78	78	78	78	78	78	78	78	78	78	78	78	78	78	78	78	78	78
Palouse	5	5	5	5	5	5	5	5	5	5	5	5	5	5	5	5	5	5	5	5
Rattlesnake Flats	8	8	8	8	8	8	8	8	8	8	8	8	8	8	8	8	8	8	8	8
Adams Nielson Solar	0	0	0	0	0	0	0	0	0	0	0	0	0	0	0	0	0	0	0	0
Placeholder	0	0	0	0	0	0	0	0	0	0	0	0	0	0	0	0	0	0	0	0
Placeholder	0	0	0	0	0	0	0	0	0	0	0	0	0	0	0	0	0	0	0	0
Coyote Springs 2	318	318	318	318	318	318	318	318	318	318	318	318	318	318	318	318	318	318	318	318
Lancaster	283	283	283	283	283	0	0	0	0	0	0	0	0	0	0	0	0	0	0	0
Colstrip (3)	0	0	0	0	0	0	0	0	0	0	0	0	0	0	0	0	0	0	0	0
Colstrip (4)	0	0	0	0	0	0	0	0	0	0	0	0	0	0	0	0	0	0	0	0
Kettle Falls	47	47	47	47	47	47	47	47	47	47	47	47	47	47	47	47	47	47	47	47
Kettle Falls CT	11	11	0	0	0	0	0	0	0	0	0	0	0	0	0	0	0	0	0	0
Boulder Park 1-6	25	25	25	25	25	25	25	25	25	25	25	25	25	25	25	25	25	25	25	0
Rathdrum 1	88	88	88	88	88	88	88	88	88	88	88	88	88	88	88	88	88	88	88	88
Rathdrum 2	88	88	88	88	88	88	88	88	88	88	88	88	88	88	88	88	88	88	88	88
Northeast A&B	66	66	66	66	66	66	66	66	66	66	66	66	66	66	0	0	0	0	0	0
<b>Net Position</b>	<b>5</b>	<b>-4</b>	<b>-2</b>	<b>-17</b>	<b>-12</b>	<b>-301</b>	<b>-307</b>	<b>-320</b>	<b>-326</b>	<b>-409</b>	<b>-415</b>	<b>-421</b>	<b>-428</b>	<b>-435</b>	<b>-509</b>	<b>-517</b>	<b>-527</b>	<b>-536</b>	<b>-547</b>	<b>-587</b>

Assumes Colstrip 3 & 4 are removed from the portfolio from 2022 to 2041 due to economic results of this study

# Demand Response

Program	Washington	Idaho
Time of Use Rates	2 MW (2024)	2 MW (2024)
Variable Peak Pricing	7 MW (2024)	6 MW (2024)
Large C&I Program	25 MW (2027)	n/a
DLC Smart Thermostats	7 MW (2031)	n/a
Third Party Contracts	14 MW (2032)	8 MW (2024)
Behavioral	1 MW (2041)	n/a
Total	56 MW	15 MW

## Notes:

- 1) Programs in another state for the benefit of the other state are not modeled
- 2) Operationally programs are likely for both states regardless of timing
- 3) 2027 start date is effectively 11/1/2027

# 2022-2025 Supply-Side Resource Changes

- 2022:** Economic to exit out of Colstrip 3 & 4 (Both States)
- 2023:** 100 MW of Montana Wind (WA)
- 2024:** 100 MW of Montana Wind (WA)
- 2025:** No Action

**NOTE: Renewable RFP may change this strategy**

# 2026-2029 Supply-Side Resource Changes

- 2026/27:** 12 MW Upgrade Kettle Falls (Both States)  
283 MW Lancaster CCCT contract ends Nov 2026 (Both States)  
126 MW NG SCCT (Both States)  
85 MW NG SCCT (ID)
- 2028:** 100 MW Montana Wind (WA)
- 2029:** No Action

**NOTE: Renewable RFP may change this strategy**



# 2030-2033 Supply-Side Resource Changes

- 2030:** No Action
- 2031:** 75 MW Hydro Contract Renewal (WA)
- 2032:** No Action
- 2033:** No Action

## 2034-2037 Supply-Side Resource Changes

- 2034:** No Action
- 2035:** 5 MW Rathdrum CT Upgrade (Both States)  
66 MW Northeast Retires (Both States)
- 2036:** 87 MW NG SCCT (Both States)
- 2037:** No Action

## 2038-2041 Supply-Side Resource Changes

- 2038:** 100 MW Solar + 50 MW 4-hour Lithium-ion Battery (Both States)
- 2039:** No Action
- 2040:** No Action
- 2041:** 25 MW Boulder Park Retires (Both States)  
100 MW Montana Wind (WA)  
36 MW Natural Gas Reciprocating Engine (ID)

# Draft Preferred Resource Strategy Selection (MW)

Nameplate MW	2022	2023	2024	2025	2026	2027	2028	2029	2030	2031	2032	2033	2034	2035	2036	2037	2038	2039	2040	2041	2042	2043	2044	2045	Total	
<b>Shared System Resource</b>																										
NG CT	-	-	-	-	-	126	-	-	-	-	-	-	-	-	87	-	-	-	-	-	-	-	-	-	-	213
Solar	-	-	-	-	-	-	-	-	-	-	-	-	-	-	-	-	100	-	-	-	-	-	-	-	-	100
Storage Added to Solar	-	-	-	-	-	-	-	-	-	-	-	-	-	-	-	-	50	-	-	-	-	-	-	-	-	50
Wind	-	-	-	-	-	-	-	-	-	-	-	-	-	-	-	-	-	-	-	-	-	-	-	-	-	-
Storage	-	-	-	-	-	-	-	-	-	-	-	-	-	-	-	-	-	-	-	-	-	-	-	-	-	-
Hydrogen	-	-	-	-	-	-	-	-	-	-	-	-	-	-	-	-	-	-	-	-	-	-	-	-	-	-
Other- (Clean Capacity)	-	-	-	-	-	-	-	-	-	-	-	-	-	-	-	-	-	-	-	-	-	-	-	-	-	-
Thermal Upgrade	-	-	-	-	12	-	-	-	-	-	-	-	-	5	-	-	-	-	-	-	-	-	-	-	-	17
Hydro	-	-	-	-	-	-	-	-	-	-	-	-	-	-	-	-	-	-	-	-	-	-	-	-	-	-
<b>Washington</b>																										
NG CT	-	-	-	-	-	-	-	-	-	-	-	-	-	-	-	-	-	-	-	-	-	-	-	-	-	-
Solar	-	-	-	-	-	-	-	-	-	-	-	-	-	-	-	-	-	-	-	-	117	122	-	149	-	388
Storage Added to Solar	-	-	-	-	-	-	-	-	-	-	-	-	-	-	-	-	-	-	-	-	58	61	-	75	-	194
Wind	-	100	100	-	-	-	100	-	-	-	-	-	-	-	-	-	-	-	-	100	-	-	-	-	-	400
Storage	-	-	-	-	-	-	-	-	-	-	-	-	-	-	-	-	-	-	-	-	-	-	12	-	-	12
Hydrogen	-	-	-	-	-	-	-	-	-	-	-	-	-	-	-	-	-	-	-	-	-	-	-	-	-	-
Other- (Clean Capacity)	-	-	-	-	-	-	-	-	-	-	-	-	-	-	-	-	-	-	-	-	-	-	-	-	-	-
Thermal Upgrade	-	-	-	-	-	-	-	-	-	-	-	-	-	-	-	-	-	-	-	-	-	-	-	-	-	-
Hydro	-	-	-	-	-	-	-	-	-	75	-	-	-	-	-	-	-	-	-	-	-	-	-	-	-	75
<b>Idaho</b>																										
NG CT	-	-	-	-	-	85	-	-	-	-	-	-	-	-	-	-	-	-	-	36	-	-	-	-	-	122
Solar	-	-	-	-	-	-	-	-	-	-	-	-	-	-	-	-	-	-	-	-	-	-	-	-	-	-
Storage Added to Solar	-	-	-	-	-	-	-	-	-	-	-	-	-	-	-	-	-	-	-	-	-	-	-	-	-	-
Wind	-	-	-	-	-	-	-	-	-	-	-	-	-	-	-	-	-	-	-	-	-	-	-	-	-	-
Storage	-	-	-	-	-	-	-	-	-	-	-	-	-	-	-	-	-	-	-	-	-	-	-	10	-	10
Hydrogen	-	-	-	-	-	-	-	-	-	-	-	-	-	-	-	-	-	-	-	-	-	-	-	-	-	-
Other- (Clean Capacity)	-	-	-	-	-	-	-	-	-	-	-	-	-	-	-	-	-	-	-	-	-	-	-	-	-	-
Thermal Upgrade	-	-	-	-	-	-	-	-	-	-	-	-	-	-	-	-	-	-	-	-	-	-	-	-	-	-
Hydro	-	-	-	-	-	-	-	-	-	-	-	-	-	-	-	-	-	-	-	-	-	-	-	-	-	-

Note: Storage resources include 16-Hour Liquid Air Energy Storage and 4-Hour Lithium-ion. Does not include results of 2020 Renewable RFP.

2021 Electric IRB Appendices



# Draft State Total Resource Selection (MW)

Nameplate MW	2022	2023	2024	2025	2026	2027	2028	2029	2030	2031	2032	2033	2034	2035	2036	2037	2038	2039	2040	2041	2042	2043	2044	2045	Total
<b>Washington</b>																									
NG CT	-	-	-	-	-	83	-	-	-	-	-	-	-	-	57	-	-	-	-	-	-	-	-	-	140
Solar	-	-	-	-	-	-	-	-	-	-	-	-	-	-	-	-	66	-	-	-	117	122	-	149	454
Storage Added to Solar	-	-	-	-	-	-	-	-	-	-	-	-	-	-	-	-	33	-	-	-	58	61	-	75	227
Wind	-	100	100	-	-	-	100	-	-	-	-	-	-	-	-	-	-	-	-	100	-	-	-	-	400
Storage	-	-	-	-	-	-	-	-	-	-	-	-	-	-	-	-	-	-	-	-	-	-	12	-	12
Hydrogen	-	-	-	-	-	-	-	-	-	-	-	-	-	-	-	-	-	-	-	-	-	-	-	-	-
Other- (Clean Capacity)	-	-	-	-	-	-	-	-	-	-	-	-	-	-	-	-	-	-	-	-	-	-	-	-	-
Thermal Upgrade	-	-	-	-	8	-	-	-	-	-	-	-	-	3	-	-	-	-	-	-	-	-	-	-	11
Hydro	-	-	-	-	-	-	-	-	-	75	-	-	-	-	-	-	-	-	-	-	-	-	-	-	75
<b>Idaho</b>																									
NG CT	-	-	-	-	-	128	-	-	-	-	-	-	-	-	30	-	-	-	-	36	-	-	-	-	195
Solar	-	-	-	-	-	-	-	-	-	-	-	-	-	-	-	-	34	-	-	-	-	-	-	-	34
Storage Added to Solar	-	-	-	-	-	-	-	-	-	-	-	-	-	-	-	-	17	-	-	-	-	-	-	-	17
Wind	-	-	-	-	-	-	-	-	-	-	-	-	-	-	-	-	-	-	-	-	-	-	-	-	-
Storage	-	-	-	-	-	-	-	-	-	-	-	-	-	-	-	-	-	-	-	-	-	-	-	10	10
Hydrogen	-	-	-	-	-	-	-	-	-	-	-	-	-	-	-	-	-	-	-	-	-	-	-	-	-
Other- (Clean Capacity)	-	-	-	-	-	-	-	-	-	-	-	-	-	-	-	-	-	-	-	-	-	-	-	-	-
Thermal Upgrade	-	-	-	-	4	-	-	-	-	-	-	-	-	2	-	-	-	-	-	-	-	-	-	-	6
Hydro	-	-	-	-	-	-	-	-	-	-	-	-	-	-	-	-	-	-	-	-	-	-	-	-	-

# Clean Energy Shares (aMW)

Washington

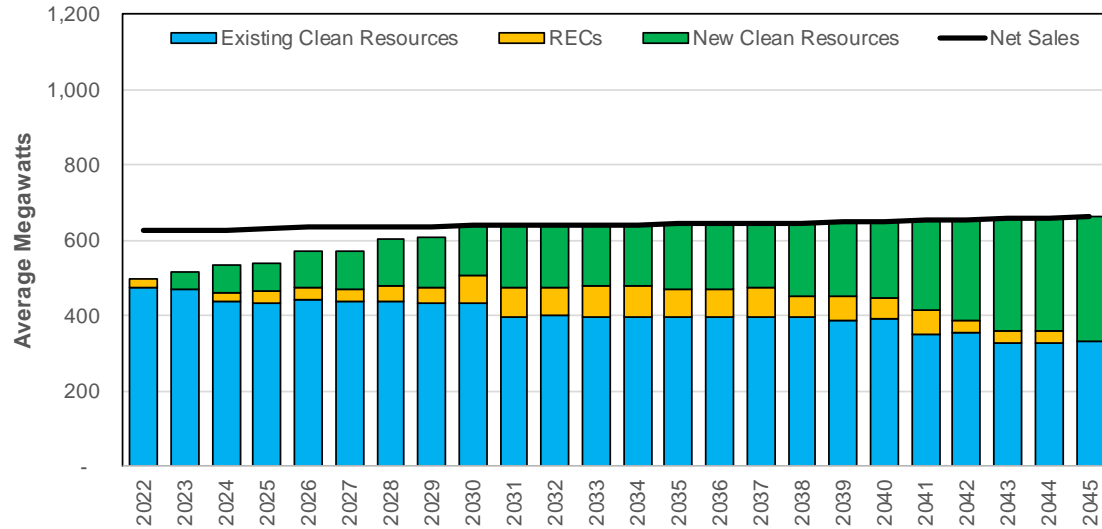

System

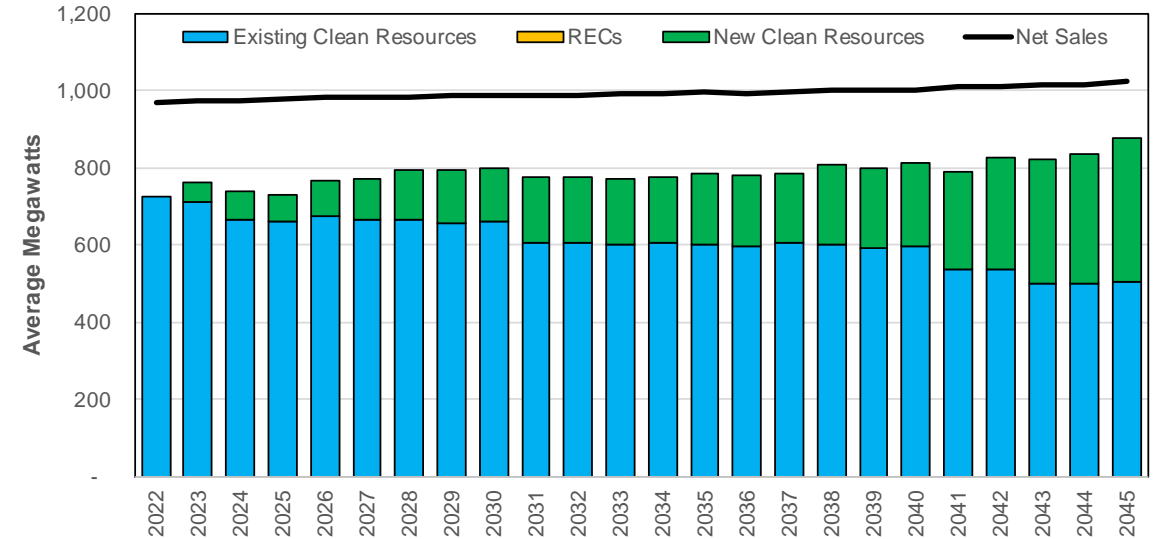

Idaho

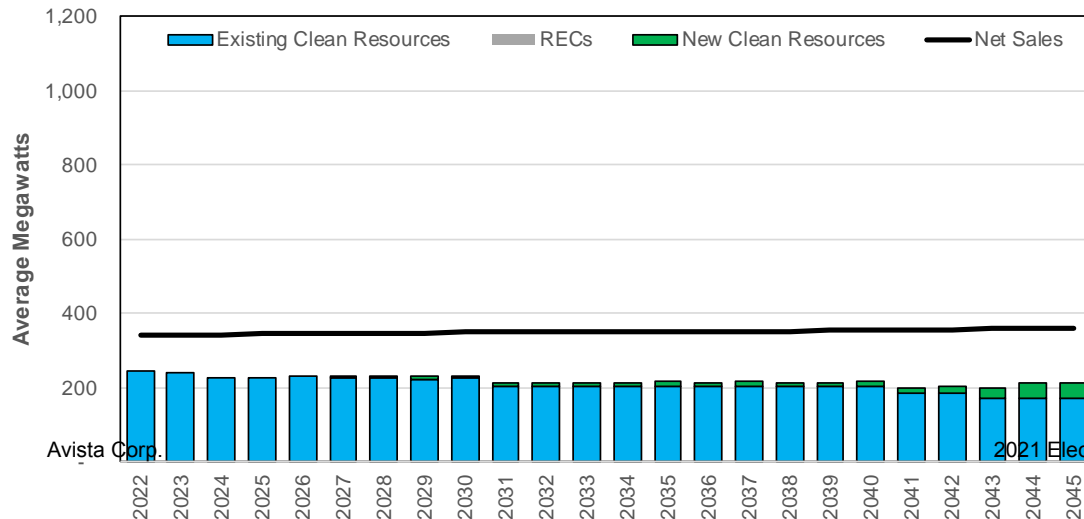

## System Clean Resource Percentage

2022: 74.8%

2027: 78.3%

2045: 85.5%

Excludes Clean Market Purchases



# Annual Average Least Reasonable Cost Rate Forecast

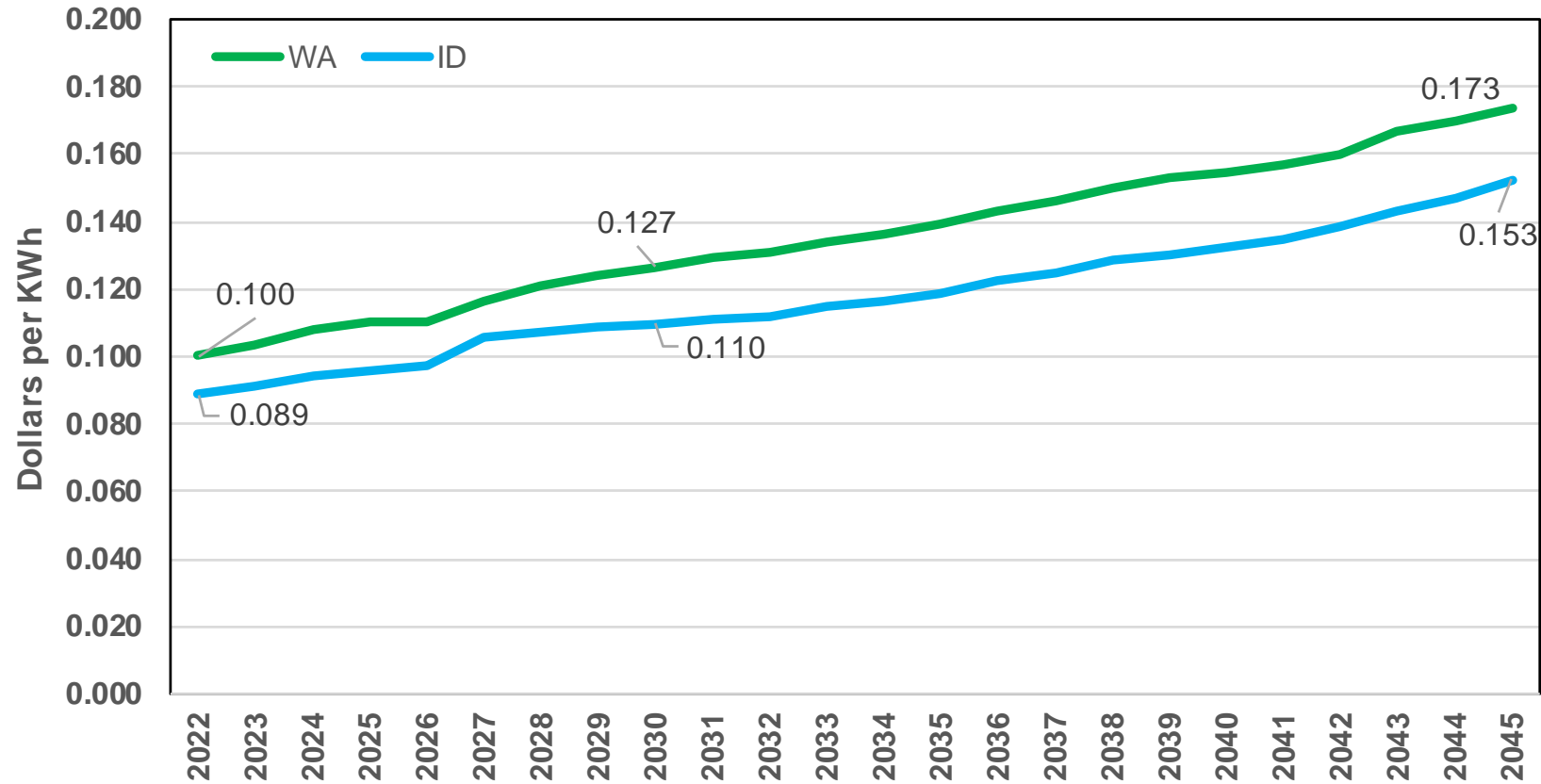

NOTE: Estimated rates only using 2% annual rate increase for non-modeled costs

# Greenhouse Gas Forecast with Draft PRS

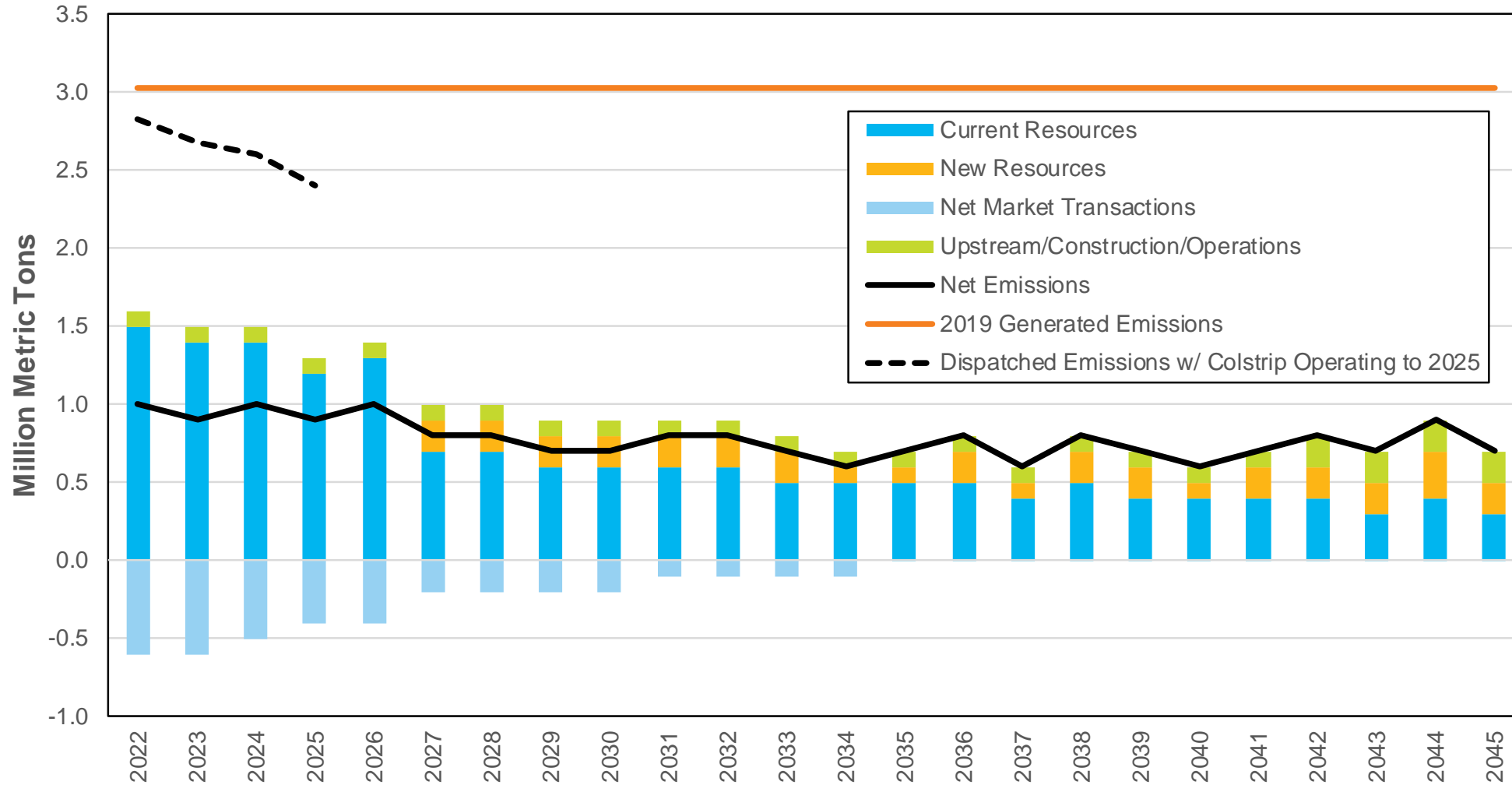

Note: Assumes Colstrip exits the portfolio in 2022

2021 Electric IRP Appendices





# New Supply-Side Resource Avoided Costs

Year	Flat (\$/MWh)	On-Peak (\$/MWh)	Off-Peak (\$/MWh)	Clean Energy Premium (\$/MWh)	Capacity Premium (\$/kW-Yr)
2022	\$20.37	\$21.66	\$18.65	\$0.00	\$0.00
2023	\$18.71	\$19.34	\$17.89	\$13.27	\$0.00
2024	\$18.73	\$19.04	\$18.32	\$13.54	\$0.00
2025	\$19.99	\$20.05	\$19.92	\$13.81	\$0.00
2026	\$23.74	\$23.68	\$23.82	\$14.09	\$0.00
2027	\$24.63	\$24.27	\$25.12	\$14.37	\$115.1
2028	\$25.67	\$24.99	\$26.58	\$14.65	\$117.4
2029	\$26.65	\$25.77	\$27.83	\$14.95	\$119.8
2030	\$26.46	\$25.48	\$27.78	\$15.25	\$122.2
2031	\$27.63	\$26.48	\$29.15	\$15.55	\$124.6
2032	\$28.02	\$26.86	\$29.57	\$15.86	\$127.1
2033	\$29.30	\$27.96	\$31.08	\$16.18	\$129.7
2034	\$29.42	\$27.98	\$31.33	\$16.50	\$132.2
2035	\$30.47	\$28.81	\$32.68	\$16.83	\$134.9
2036	\$32.10	\$30.38	\$34.41	\$17.17	\$137.6
2037	\$31.95	\$30.08	\$34.45	\$17.51	\$140.3
2038	\$34.46	\$32.26	\$37.39	\$17.86	\$143.1
2039	\$34.77	\$32.31	\$38.04	\$18.22	\$146.0
2040	\$35.67	\$33.15	\$39.01	\$18.58	\$148.9
2041	\$38.23	\$35.77	\$41.52	\$18.96	\$151.9
2042	\$38.71	\$36.40	\$41.79	\$19.34	\$154.9
2043	\$39.27	\$36.92	\$42.40	\$19.72	\$158.0
2044	\$46.82	\$44.18	\$50.34	\$20.12	\$161.2
2045	\$46.45	\$44.31	\$49.28	\$20.52	\$164.4
<b>20 yr Levelized</b>	<b>\$25.85</b>	<b>\$25.20</b>	<b>\$26.72</b>	<b>\$14.04</b>	<b>\$80.3</b>
<b>24 yr Levelized</b>	<b>\$27.18</b>	<b>\$26.39</b>	<b>\$28.22</b>	<b>\$14.50</b>	<b>\$86.6</b>

2024 Electric IR - Appendices



# Portfolio Scenario and Market Sensitivity Analysis

James Gall, Electric IRP Manager  
Technical Advisory Committee Update Meeting  
December 16, 2020

# Safe Harbor Statement

This document contains forward-looking statements. Such statements are subject to a variety of risks, uncertainties and other factors, most of which are beyond the Company's control, and many of which could have a significant impact on the Company's operations, results of operations and financial condition, and could cause actual results to differ materially from those anticipated.

For a further discussion of these factors and other important factors, please refer to the Company's reports filed with the Securities and Exchange Commission. The forward-looking statements contained in this document speak only as of the date hereof. The Company undertakes no obligation to update any forward-looking statement or statements to reflect events or circumstances that occur after the date on which such statement is made or to reflect the occurrence of unanticipated events. New risks, uncertainties and other factors emerge from time to time, and it is not possible for management to predict all of such factors, nor can it assess the impact of each such factor on the Company's business or the extent to which any such factor, or combination of factors, may cause actual results to differ materially from those contained in any forward-looking statement.

# Scenario Descriptions

1. **Least Reasonable Cost Strategy:** Includes all requirements
2. **Baseline Portfolio 1:** Excludes CETA's 2030 and 2045 goals
  - Used for incremental cost calculation
3. **Baseline Portfolio 2:** Baseline Portfolio 1 + removal of SCC
  - Energy Efficiency held constant from LCS
4. **Baseline Portfolio 3:** Baseline Portfolio 2 + removal of capacity constraints
  - Energy Efficiency held constant from LCS
5. **Clean Resource Plan (2027)**
  - Add constraint to meet or exceed 100% of all retail sales with clean energy
6. **Clean Resource Plan (2045)**
  - Add constraint to meet or exceed 100% of all retail sales with clean energy
  - All thermal resources must exit by 2044
  - No new thermal resources
7. **Social Cost of Carbon applied to Idaho**
  - Includes SCC as cost adder to generation and savings for EE using same method as Washington State

# Scenario Descriptions (Continued)

- 8. Least Cost Plan- with low load growth**
  - Loads decline by 0.11% per year vs. +0.31% per year
- 9. Least Cost plan- with high load growth**
  - Loads increase by 0.73% per year vs. +0.31% per year
- 10. Least Cost Plan- w/ Northwest Resource Adequacy Market Peak Credits**
  - Use Regional Planning Margin of 12% & Regional Peak Credits
- 11. Heating Electrification Scenario 1**
  - WA customers electrify with exiting heating technology
- 12. Heating Electrification Scenario 2**
  - WA customers electrify using hybrid systems (i.e. NG furnace & electric HP & HPWH)
- 13. Heating Electrification Scenario 3**
  - WA customer electrify using technology without COP rates not falling below freezing temperatures
- 14. Least Cost Plan- with 2 time SCC prices**
  - Double of Social Cost of Carbon charge for Washington Only

# Scenario Descriptions (Continued)

## 15. Colstrip serves Idaho customers through 2025

- Colstrip obligated to run through 2025 in both states

## 16. Colstrip serves Idaho customers through 2035

- Colstrip obligated to run through 2035 for Idaho

## 17. Colstrip serves Idaho customers through 2045

- Colstrip obligated to run through 2045 for Idaho

## 18. CETA delivers by the hour

- Approximates resource selection requiring clean energy delivery by hour

## 19. Social Cost of Carbon applied to net purchases/sales

- Includes SCC planning penalty on the net of market purchases/sales (2020 IRP assumption)

## 20. Average Market Emissions Rate applied to Energy Efficiency SCC

- Replaces incremental market emissions for average market emissions for SCC on EE (2020 IRP assumption)

# Scenario Descriptions (Continued)

## 1a. Least Cost Plan with Climate Shift

- Re-optimized PRS with alternate load and generation forecast assuming warming temperatures

## 1b. Least Cost Plan with Social Cost of Carbon “Tax”

- Re-optimized PRS with market carbon tax on fossil fuel generation

# Scenario & Sensitivity List

Number	Scenario	Expected Case	High N. Gas Price	Low N. Gas Price	Social Cost Carbon Tax	Climate Shift	
1	Preferred Resource Strategy	X	X	X	X		
2	Baseline Portfolio 1 (No CETA renewable targets)	X					
3	Baseline Portfolio 2 (No CETA renewable targets/SCC)	X	X	X	X		
4	Baseline Portfolio 3 (No Capacity Constraints)	X					
5	Clean Resource Plan (100% Portfolio net clean by 2027)	X	X	X	X		
6	Clean Resource Plan (100% Portfolio clean by 2045)	X	X	X	X		
7	Social Cost of Carbon applied to Idaho	X					
8	Least Cost Plan- w/ low load growth	X					
9	Least Cost Plan- w/ low load growth	X					
10	Least Cost Plan- w/ Northwest Resource Adequacy Market Peak Credits	X					
11	Heating Electrification Scenario 1	X					
12	Heating Electrification Scenario 2	X					
13	Heating Electrification Scenario 3	X					
14	Least Cost Plan- w/ 2x SCC prices	X					
15	Colstrip serves Idaho customers through 2025	X	X	X	X		
16	Colstrip serves Idaho customers through 2035	X	X	X	X		
17	Colstrip serves Idaho customers through 2045	X	X	X	X		
18	CETA deliver each hour	X					
19	Social Cost of Carbon applied to net Purchases/Sales	X					
20	Avg market emissions rate applied to SCC for EE	X					
1a	Least Cost Plan- w/ climate shift	2021 Electric IRP Appendices					X
1b	Least Cost Plan- w/ SCC "Tax"				X		



# Scenario Cumulative Resource Selection

	1- Preferred Resource Strategy	2- Baseline 1	3- Baseline 2	4- Baseline 3	5- Clean Resource Plan (2027)	6- Clean Resource Plan (2045)	7- SCC Idaho	8- Low Load Forecast	9- High Load Forecast	10- RA Market	11- Electrification 1	12- Electrification 2	13- Electrification 3	14- 2x SCC	15- Colstrip Exit 2025	16- Colstrip Exit 2035	17- Colstrip Exit 2045	18- Clean Energy Delivered Each Hour	19- SCC on Net P/S	20- Use Avg Mkt for EE SCC	1a- LCP w/ Climate Shift	1b- LCP w/ SCC
<b>Shared System Resource</b>																						
NG CT	213	132	132	0	84	0	223	65	84	88	84	84	84	196	213	125	211	126	250	86	172	247
Solar	100	0	0	0	549	899	0	104	0	100	0	0	0	100	100	100	100	100	0	101	-	411
Storage Added to Solar	50	0	0	0	275	450	0	52	0	50	0	0	0	50	50	50	50	50	0	50	-	206
Wind	0	0	0	0	0	200	0	0	0	0	0	0	0	0	0	0	0	0	0	0	-	323
Storage	0	0	0	0	0	0	0	0	0	0	0	0	0	0	0	0	0	0	0	0	-	9
Hydrogen	0	0	0	0	0	0	0	0	0	0	0	0	0	0	0	0	0	0	0	0	-	-
Other- (Clean Capacity)	0	0	0	0	20	0	0	0	0	0	0	0	0	0	0	0	0	0	0	0	-	-
Thermal Upgrade	17	17	17	0	17	12	17	17	21	17	17	17	17	17	17	17	17	17	17	17	21	17
Hydro	0	75	75	0	0	75	75	0	0	0	0	0	0	0	0	0	0	0	0	0	-	75
<b>Washington</b>																						
NG CT	0	144	147	0	48	0	0	48	92	49	200	159	200	0	0	51	0	0	0	84	-	-
Solar	388	0	0	0	26	0	496	131	493	552	277	536	425	379	388	388	387	788	120	389	372	-
Storage Added to Solar	194	0	0	0	0	0	248	0	246	94	138	268	212	189	194	194	194	369	60	194	111	-
Wind	400	0	0	0	400	400	400	400	514	300	894	628	796	400	400	400	400	700	616	400	400	350
Storage	12	68	68	0	24	312	22	0	113	0	486	279	474	23	12	22	13	512	22	12	21	865
Hydrogen	0	0	0	0	0	75	0	0	0	0	397	84	199	0	0	0	0	0	0	0	-	-
Other- (Clean Capacity)	0	0	0	0	0	96	0	0	20	0	20	20	20	0	0	0	0	100	0	0	-	-
Thermal Upgrade	0	0	0	0	0	0	0	0	0	0	0	0	0	0	0	0	0	0	0	0	-	-
Hydro	75	0	0	0	75	0	0	75	75	75	75	75	75	75	75	75	75	75	75	75	75	-
DR Capability	56	104	97	3	56	104	57	49	49	34	49	49	49	49	57	56	56	56	49	56	49	35
EE- Winter Capacity	86	85	86	86	89	92	86	86	86	85	118	114	114	88	86	86	86	86	85	81	86	87
EE- Summer Capacity	92	92	92	92	100	101	93	92	92	96	121	97	99	94	92	92	92	92	92	79	97	115
<b>Idaho</b>																						
NG CT	122	97	97	0	148	0	57	135	194	148	91	132	91	127	122	165	73	158	92	169	120	-
Solar	0	0	0	0	200	250	0	0	0	0	0	0	0	0	0	0	0	0	0	0	5	-
Storage Added to Solar	0	0	0	0	0	50	0	0	0	0	0	0	0	0	0	0	0	0	0	0	-	-
Wind	0	0	0	0	194	200	0	0	0	0	0	0	0	0	0	0	0	0	0	0	-	327
Storage	10	20	33	0	0	20	10	0	28	49	26	16	26	29	10	24	24	10	34	10	-	176
Hydrogen	0	50	50	0	0	232	50	0	50	0	100	50	100	0	0	0	0	0	0	0	-	-
Other- (Clean Capacity)	0	0	0	0	0	20	0	0	0	0	0	0	0	0	0	0	0	0	0	0	-	-
Thermal Upgrade	0	0	0	0	0	0	0	0	0	0	0	0	0	0	0	0	0	0	0	0	-	-
Hydro	0	0	0	0	0	68	0	0	0	0	0	0	0	0	0	0	0	0	0	0	-	-
DR Capability	15	18	20	2	16	20	19	8	16	19	19	18	19	18	15	9	9	15	15	19	16	8
EE- Winter Capacity	24	29	24	24	31	37	38	24	24	24	32	29	32	25	24	22	21	24	29	25	24	39
EE- Summer Capacity	13	13	13	13	26	30	35	13	13	20	15	13	15	13	13	11	11	13	13	13	35	53



# Existing Resource “Exits”

	1- Preferred Resource Strategy	2- Baseline 1	3- Baseline 2	4- Baseline 3	5- Clean Resource Plan (2027)	6- Clean Resource Plan (2045)	7- SCC Idaho	8- Low Load Forecast	9- High Load Forecast	10- RA Market	11- Electrification 1	12- Electrification 2	13- Electrification 3	14- 2x SCC	15- Colstrip Exit 2025	16- Colstrip Exit 2035	17- Colstrip Exit 2045	18- Clean Energy Delivered Each Hour	19- SCC on Net P/S	20- Use Avg Mrkt for EE SCC	1a- LCP w/ Climate Shift	1b- LCP w/ SCC
Coyote Springs 2	-	-	-	-	-	2044	-	-	-	-	-	-	-	-	-	-	-	-	-	-	-	-
Lancaster	2026	2026	2026	2026	2026	2026	2026	2026	2026	2026	2026	2026	2026	2026	2026	2026	2026	2026	2026	2026	2026	2026
Colstrip (3)	2021	2021	2021	2021	2021	2044	2021	2021	2021	2021	2021	2021	2021	2021	2025	2035	-	2021	2021	2021	2021	2021
Colstrip (4)	2021	2021	2021	2021	2021	2021	2021	2021	2022	2021	2021	2021	2021	2021	2025	2035	-	2021	2021	2021	2021	2021
Kettle Falls	-	-	-	-	-	-	-	-	-	-	-	-	-	-	-	-	-	-	-	-	-	-
Kettle Falls CT	-	-	-	-	-	2044	-	-	-	-	-	-	-	-	-	-	-	-	-	-	-	-
Boulder Park 1-6	2040	2040	2040	2040	2040	2040	2040	2040	2040	2037	2040	2040	2040	2040	2040	2040	2040	2040	2039	2040	2040	2040
Rathdrum 1	-	-	-	-	-	2044	-	-	-	-	-	-	-	-	-	-	-	-	-	-	-	-
Rathdrum 2	-	-	-	-	-	2044	-	-	-	-	-	-	-	-	-	-	-	-	-	-	-	-
Northeast A&B	2035	2035	2035	2035	2035	2035	2035	2035	2035	2035	2035	2035	2035	2035	2035	2035	2035	2035	2035	2035	2035	2035

**Note:**

Assumes each plant is available through December 31<sup>st</sup> of the final year;

Exception: Lancaster PPA expires Oct 2026.

Dash indicates no plant exit in the study



# 2022-45 Levelized Revenue Requirement Delta from PRS

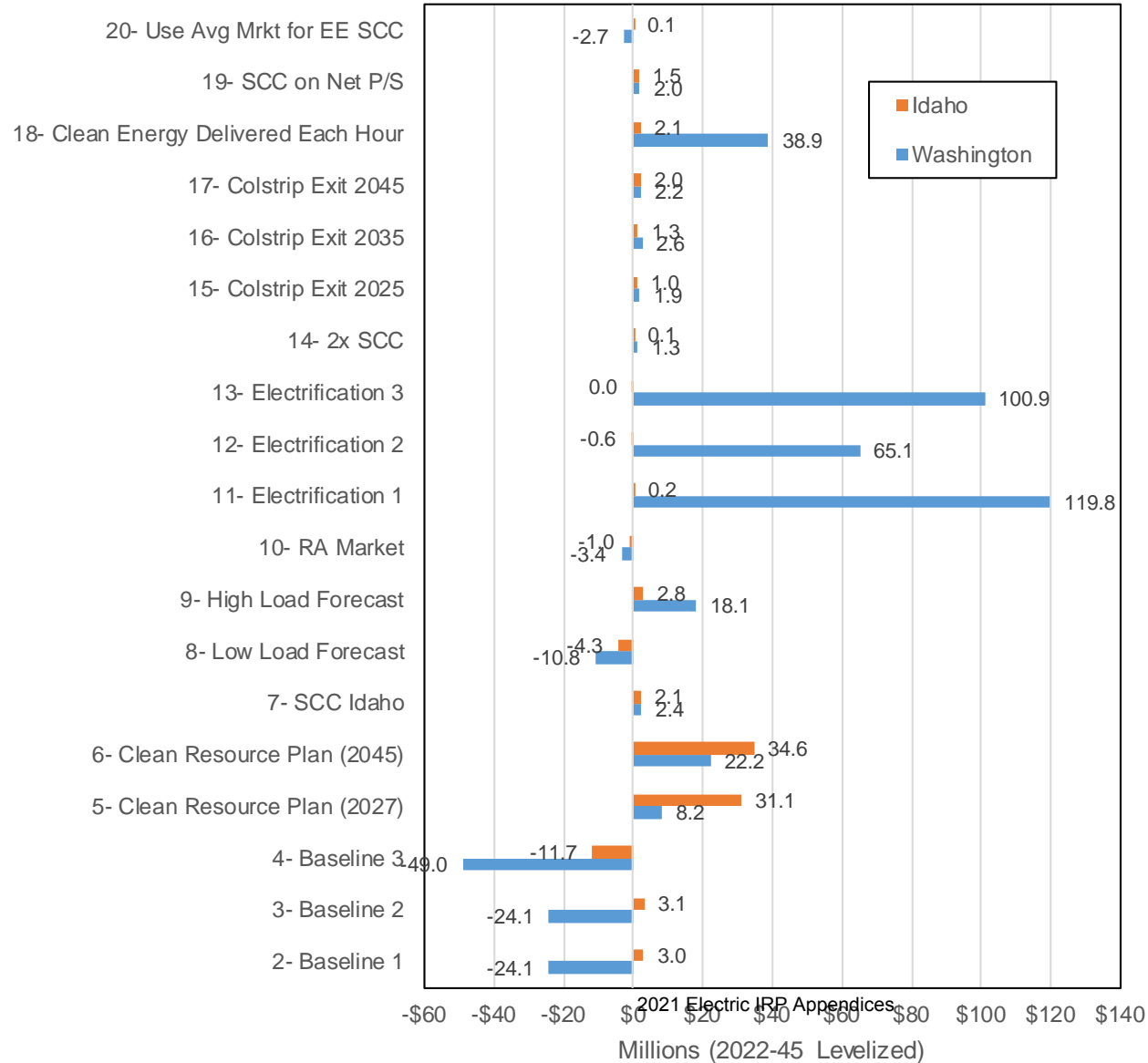

# Avg Energy Rate Delta from PRS (2030 & 2045)

## Washington

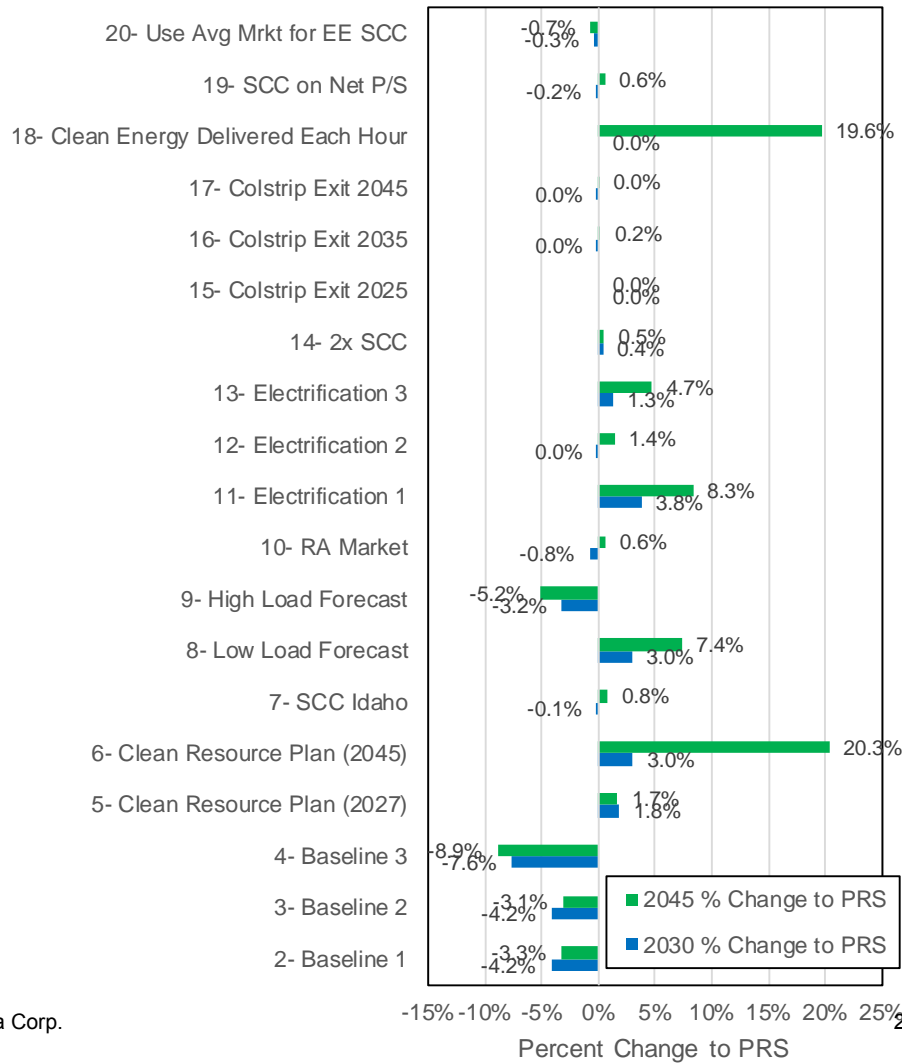

## Idaho

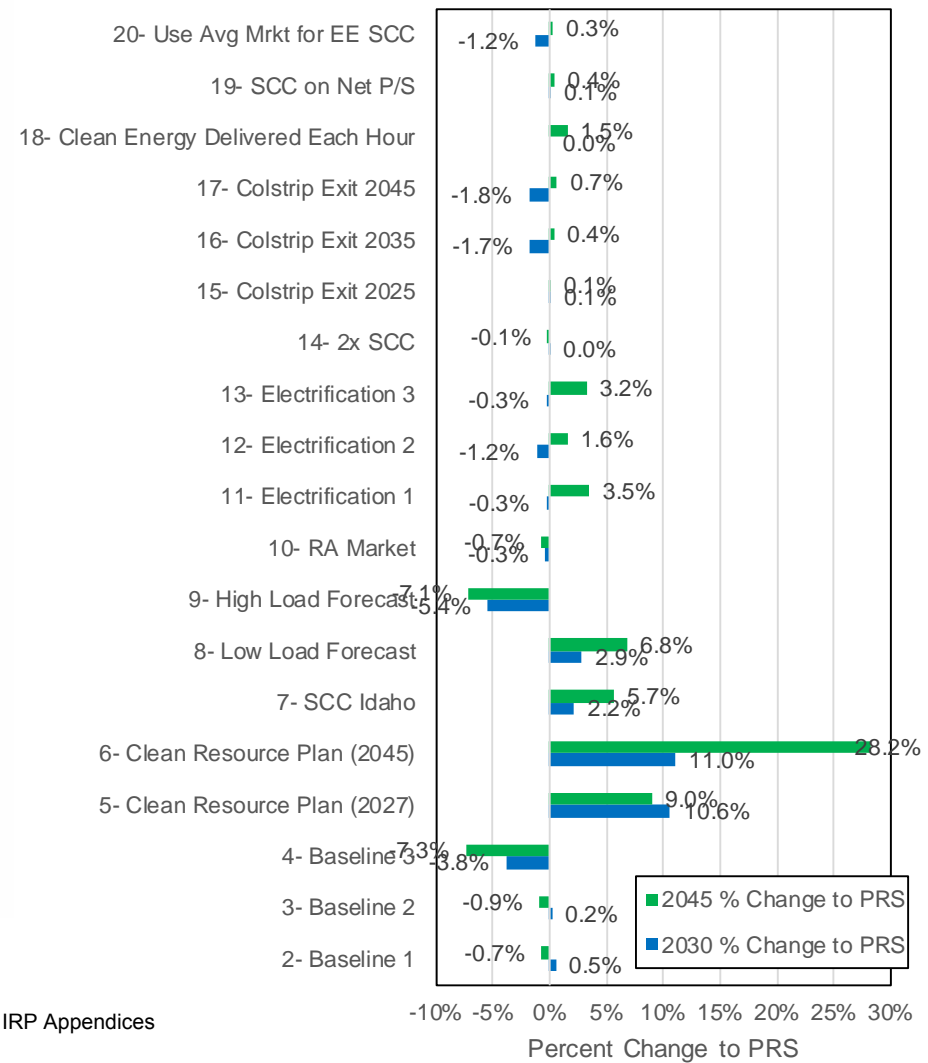

# Annual Greenhouse Gas Emission

## Avista Dispatched GHG Emissions

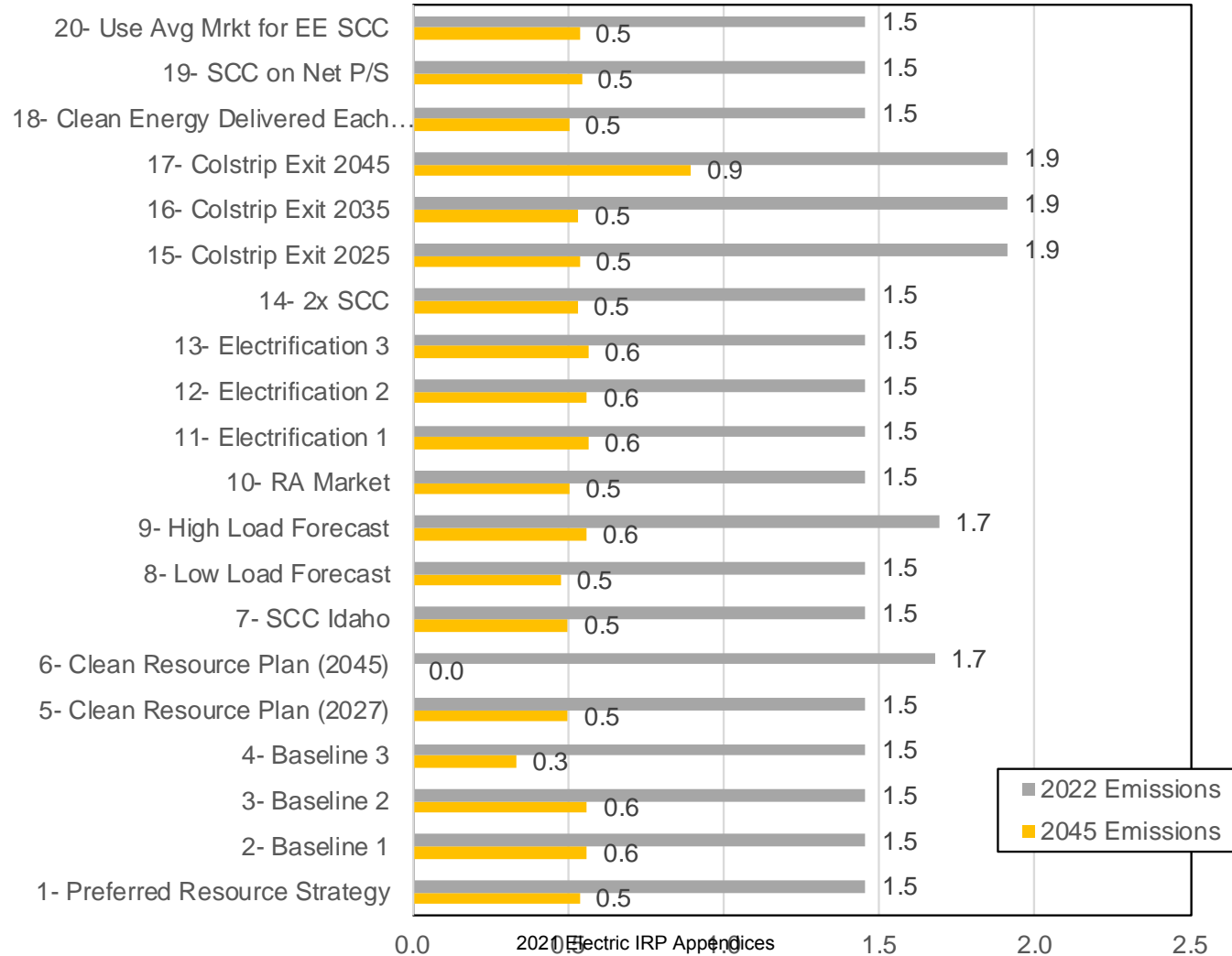

# Cost vs. GHG Tradeoffs

## Change in Levelized Cost vs. Change in Levelized Net Emissions

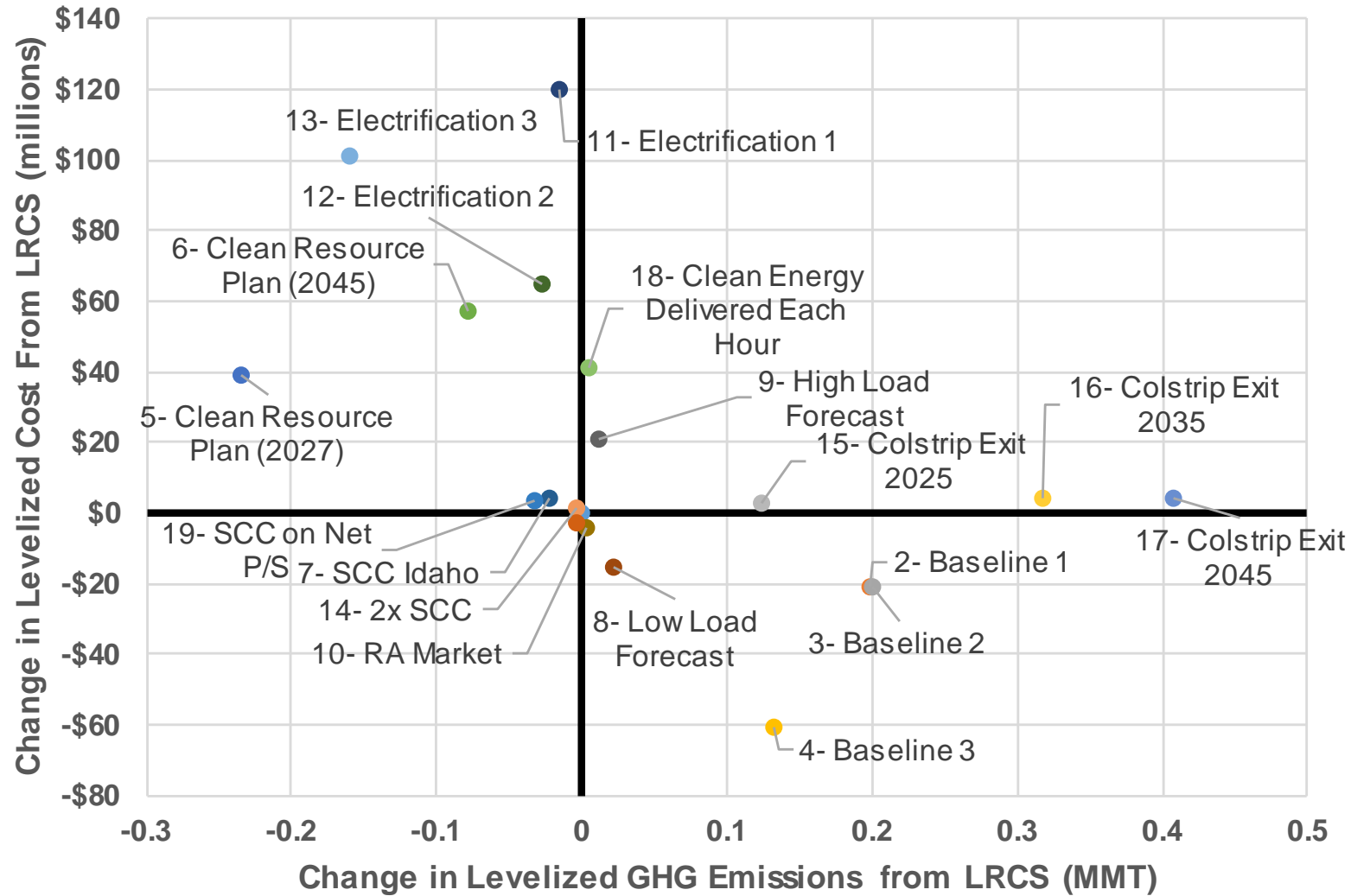

2021 Electric IRP Appendices



# 2030 Risk Analysis

Measures 2030 standard deviation of “modeled” power cost compared to levelized cost

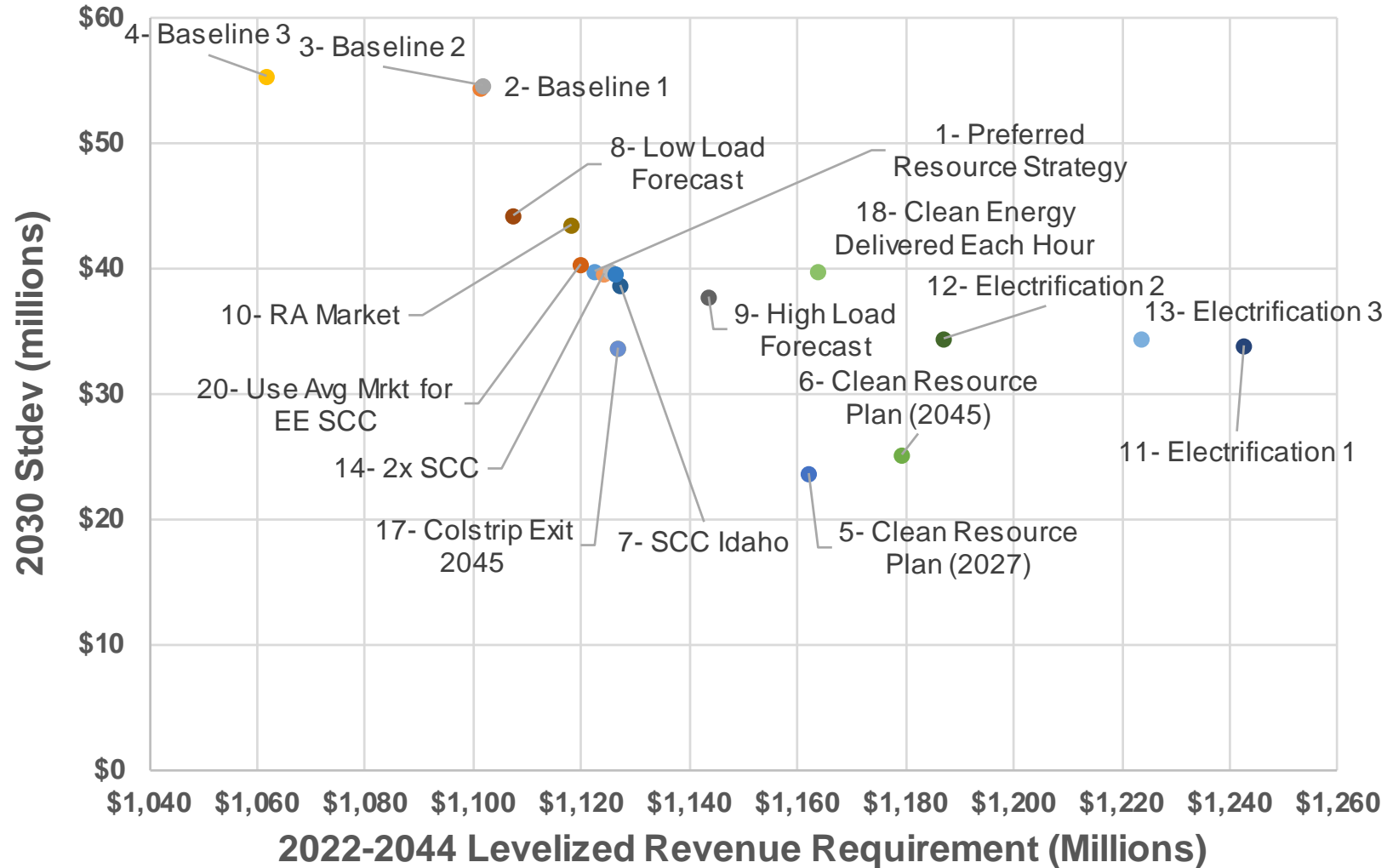

# 2045 Upper Tail Risk Analysis

95<sup>th</sup> percentile power cost minus mean power cost compared to levelized cost

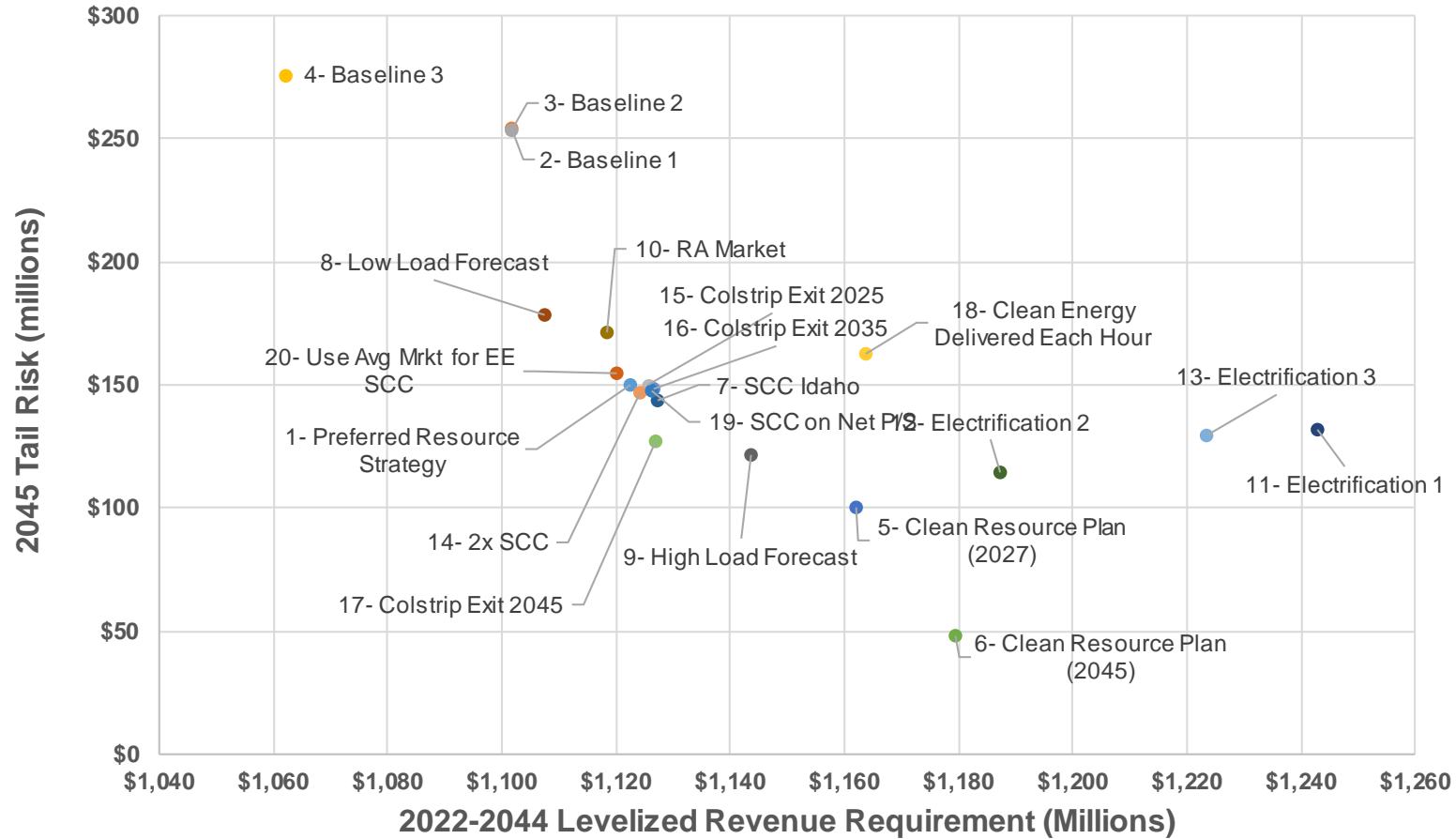



# Portfolio Results Summary

Scenario	WA- PVRR (\$ Mill)	ID-PVRR (\$ Mill)	WA 2030 Rate (\$/kWh)	WA 2045 Rate (\$/kWh)	ID 2030 Rate (\$/kWh)	ID 2045 Rate (\$/kWh)	2030 Stdev (\$ Mill)	2045 Stdev (\$ Mill)	2045 Tail Risk (\$ Mill)	2045 GHG Emissions (MT)
1- Preferred Resource Strategy	8,703	4,543	0.127	0.173	0.110	0.153	40	87	150	0.54
2- Baseline 1	8,418	4,578	0.121	0.168	0.110	0.152	54	148	254	0.56
3- Baseline 2	8,418	4,580	0.121	0.168	0.110	0.151	55	148	253	0.56
4- Baseline 3	8,125	4,405	0.117	0.158	0.106	0.141	55	162	276	0.33
5- Clean Resource Plan (2027)	8,800	4,910	0.129	0.176	0.121	0.166	24	56	100	0.50
6- Clean Resource Plan (2045)	8,965	4,951	0.130	0.209	0.122	0.196	25	35	48	0.00
7- SCC Idaho	8,732	4,568	0.126	0.175	0.112	0.161	39	82	143	0.50
8- Low Load Forecast	8,575	4,492	0.130	0.186	0.113	0.163	44	101	178	0.48
9- High Load Forecast	8,916	4,576	0.123	0.164	0.104	0.142	38	70	122	0.56
10- RA Market	8,663	4,531	0.126	0.174	0.109	0.152	43	94	171	0.50
11- Electrification 1	10,117	4,545	0.131	0.188	0.109	0.158	34	88	132	0.57
12- Electrification 2	9,471	4,536	0.127	0.176	0.109	0.155	34	71	115	0.56
13- Electrification 3	9,894	4,543	0.128	0.181	0.109	0.158	34	85	129	0.57
14- 2x SCC	8,718	4,544	0.127	0.174	0.110	0.152	40	85	147	0.53
15- Colstrip Exit 2025	8,725	4,555	0.127	0.173	0.110	0.153	40	87	150	0.54
16- Colstrip Exit 2035	8,734	4,558	0.127	0.174	0.108	0.153	34	85	148	0.53
17- Colstrip Exit 2045	8,729	4,567	0.127	0.173	0.108	0.154	34	72	127	0.89
18- Clean Energy Delivered Each Hour	9,162	4,567	0.127	0.207	0.110	0.155	40	115	162	0.50
19- SCC on Net P/S	8,726	4,561	0.126	0.174	0.110	0.153	40	84	148	0.54
20- Use Avg Mrkt for EE SCC	8,671	4,543	0.126	0.172	0.108	0.153	40	88	154	0.54

# Reoptimized Portfolios with Market Changes

- Studies how PRS would change given fundamental shift in energy planning future.
- Stochastics are not modeled
  - 1a: Climate Shift
  - 1b: SCC Tax

Deterministic Scenario	WA- PVRR (\$ Mill)	ID-PVRR (\$ Mill)	WA 2030 Rate (\$/kWh)	WA 2045 Rate (\$/kWh)	ID 2030 Rate (\$/kWh)	ID 2045 Rate (\$/kWh)	2045 GHG Emissions (MT)
1- Preferred Resource Strategy	8,690	4,545	0.126	0.173	0.110	0.153	0.40
1a- LCP w/ Climate Shift	8,597	4,498	0.125	0.171	0.109	0.149	0.35
1b- LCP w/ SCC	8,854	4,766	0.128	0.168	0.119	0.159	0.23

# Sensitivity Comparative Analysis

	Change in PVRR vs Expected Case				Change in Levelized GHG MT vs Expected Case		
Portfolio	High NG Prices	Low NG Prices	SCC		High NG Prices	Low NG Prices	SCC
1- Preferred Resource Strategy	6.1%	-2.1%	5.5%		-18%	16%	-18%
3- Baseline 2	8.8%	-3.0%	11.5%		-18%	17%	-18%
5- Clean Resource Plan (2027)	3.6%	-1.3%	-0.1%		-18%	16%	-18%
6- Clean Resource Plan (2045)	2.6%	-0.9%	0.0%		-12%	6%	-25%
15- Colstrip Exit 2025	5.7%	-2.0%	5.7%		-14%	11%	-23%
16- Colstrip Exit 2035	5.2%	-1.8%	6.6%		-11%	5%	-30%
17- Colstrip Exit 2045	4.8%	-1.7%	7.3%		-10%	3%	-31%
	Change in PVRR vs PRS				Change in Levelized GHG MT vs PRS		
Portfolio	High NG Prices	Low NG Prices	SCC		High NG Prices	Low NG Prices	SCC
3- Baseline 2	1%	-3%	4%		1%	1%	1%
5- Clean Resource Plan (2027)	1%	5%	-2%		-1%	-2%	-1%
6- Clean Resource Plan (2045)	2%	7%	0%		33%	13%	13%
15- Colstrip Exit 2025	0%	0%	0%		23%	13%	11%
16- Colstrip Exit 2035	0%	1%	1%		59%	32%	25%
17- Colstrip Exit 2045	-1%	1%	2%		75%	41%	34%

## 2021 Electric IRP TAC 4.5 Meeting Notes, December 16, 2020

Shawn Bonfield, Lori Hermanson, Kein Keyt, Mike Morrison, Morgan Brummund, Dean Sprattt, Amanda Ghering, Grant Forsyth, Clint Kalich, James McDougall, Jason Thackston, Scott Kinney, Logan Callen, Corey Dahl, Dainee Gibson-Webb, Fred Heutte, Jared Hansen, Ian McGetrick, John Chatburn, Jorgen Rasmussen, Katie Ware, Michael Eldred, Mike Morrison, Rachelle Farnsworth, Shay Bauman, Jennifer SnyderShelly McNeilly, Ricky Davis, MARRISA Warren, Joni Bosh, and Katie Pagan.

Notes in *italics* are the short responses from the presenter.

**Mike Morrison via chat:** Please explain how Cumulative Energy Efficiency is determined. (The Cumulative Part.)

**James Gall:** It is the total amount acquired to date of the prorata period.

**Mike Morrison:** What about retirements?

**James Gall:** The AEG forecast includes those retirements, so it's included this in. Energy efficiency trails off at the end of 2045 due to this.

**Mike Morrison:** What would be relevant are the cumulative amounts of what's still in place [for energy efficiency].

**James Gall:** I think that's what is included here, but we should confirm with AEG.

**Mike Morrison:** What about capacity savings?

**James Gall:** Coming up.

**Mike Morrison:** Were the planning margin forecasts computed assuming increased renewable use?

**James Gall:** Two ways to address that issue. Can either increase your planning margin or decrease the peak credit on renewables. We chose to decrease the renewable peak credit.

**Fred Huette:** On DR, can you speak to water heaters, heat pumps, etc., and what it looks like in terms of cost effectiveness?

**James Gall:** I was surprised that one wasn't picked up. I would imagine that when we do our plan in 4 years, it'll probably get selected. I think it was on the margin for this IRP.

**Fred Heutte:** We will be recommending to move on this anyway.

**Jennifer Snyder:** A pilot CTA – 2045 program would likely make sense in the CEIP. Yes.

**Fred Heutte:** You may already know this, but today in the Spokesman was a great headline regarding Rattlesnake Flat Wind going online – congratulations.

**James Gall:** Thank you!

**Mike Morrison:** A couple of slides ago, planning margin reserves and regulation for new renewable resources. Can you walk through the Montana wind and what it was before and after you derate it?

**James Gall:** For 35% capacity credit at 200 MW, there is 70 MW of reliable energy. We exchange a gas CT for wind and then determine at what level we reach the LOLP of 5%. We then compare that amount of wind with the gas CT to get to the 5% LOLP. We had to discount wind by 35% to get to the same capacity. It declines as you get more wind.

**Mike Morrison:** What about diversity of wind farms located all over?

**James Gall:** In Montana there is a large probability of wind when it's cold in Spokane, unlike northwest wind. Adding more wind decreases the capacity peak credit. Wind diversity helps with regulation, but there is still a capacity issue.

**Mike Morrison:** Your critical need seems to be in the winter. Why are you focusing on winter?

**James Gall:** Sometimes those events aren't Avista-driven. There was one summer event in 2004. Winter is really our concern.

**Mike Morrison:** I think your IRP mentions others. Summer curtailments – you've had three events in the summer.

**Fred Heutte:** Montana wind capacity factor is 35-40%, but you're using ELCC to arrive at 35% peak capacity credit under stress conditions, is that correct? Yes. It's a big state and that doesn't seem out of range. Have you considered matching wind with storage?

**James Gall:** We have not modeled matching wind with storage together, even though we have modeled them separately. We have modeled solar plus storage. In our last renewable RFP, we only had one combined solar plus storage proposal so we may look at this for the next IRP. It may be more reduction or integration cost, we will look at this in the next IRP.

**Fred Heutte:** You're mostly hydro so you have more flexibility versus a stand alone resource and some opportunities.

**James Gall:** Potentially

**Fred Heutte:** Clean energy premium would be added to the first three columns for Washington?

**James Gall:** Yes, for example a new flat PPA would get both the clean energy premium and a capacity premium based on the profile of the resource.

**Fred Heutte:** What will happen with the off-peak and on-peak price flips?

**James Gall:** With all of the new solar in California and across the west, this causes the prices to flip during the day with the result being no market to sell into during our daytime peak. We have a super-peak price too in the evening peak.

**Fred Heutte:** On slide 15, in 2027 you have a CT for Washington and Idaho. How is this one allocated to the states?

**James Gall:** It could be either. We tried to illustrate the driver for the resource need.

**Jennifer Snyder:** Baseline portfolio 2, you ran it four times.

**James Gall:** We used that scenario with different market variables to show how that portfolio would do in a high or low gas price market, etc. This helps us understand the limitations of that portfolio in different market futures.

**Fred Heutte:** What is the purpose of portfolio 18?

**James Gall:** If the commission decides by 2030 for clean energy needing to be delivered to load by hour. This case was done to determine our best guess of how to do that. It shows the cost impacts of that change from matching generation to load by the hour.

**Fred Heutte:** Our understanding is it is not hour by hour, but it is interesting to look at.

**Jennifer Snyder:** What is the cost difference in Washington based on differing exit dates for Colstrip from 2022 to 2025?

**James Gall:** Because we have a shared system, the resource choices Idaho makes may impact Washington. Idaho may be long and may decide not to participate in some of the resources. That is why the costs could be lower or higher in Washington. It depends on if they stand alone on a resource choice versus splitting the costs with Idaho customers.

**Fred Heutte:** What are the minimum machine requirements to run PRiSM?

**James Gall:** There are not any machine minimums, but software requirements. Must have a license and a modern machine with 4-8 gigs of RAM to probably solve in about 8 hours. Could get that down to minutes or to an hour with a better machine.

**Fred Heutte:** That gives a sense of the feasibility so thanks for doing this.

**Fred Heutte:** I would like to try a scenario with a lot of batteries, DR, etc. and see what it takes to max out the system. Run one scenario with high performance, flexible and clean resources.

**Mike Morrison:** Could you explain ARAM?

**James Gall:** After the January 4, 2021 filing we could schedule a one hour meeting to go through that.



***2021 Electric Integrated Resource Plan***  
**Technical Advisory Committee Meeting No. 5 Agenda**  
**Thursday, January 21, 2021**  
**Virtual Meeting**

<b>Topic</b>	<b>Time</b>	<b>Staff</b>
Introductions	9:00	Lyons
Review Draft 2021 IRP	9:15	Lyons
Draft Resource Plans and Scenarios	9:45	Gall
2021 IRP Action Items	10:45	Lyons
Lunch	11:30	
ARAM Model Overview	12:30	Gall
Break	1:30	
Clean Energy Implementation Plan and Clean Energy Action Plan Discussion	1:45	Gall/Lyons
Draft IRP Comments from TAC	2:15	
Adjourn	3:30	

.....  
[→ Join Skype Meeting](#)

Trouble Joining? [Try Skype Web App](#)

Join by phone

[509-495-7222](#) (Spokane)

English (United States)

[Find a local number](#)

Conference ID: 67816

[Forgot your dial-in PIN?](#) | [Help](#)

.....





# 2021 Electric IRP TAC Introductions and IRP Process Updates

John Lyons, Ph.D.  
Fifth Technical Advisory Committee Meeting  
January 21, 2021

# Updated TAC Meeting Guidelines

- IRP team working remotely through the rest of this IRP, but still available by email and phone for questions and comments
- Some processes are taking longer remotely
- Virtual IRP meetings until able to hold large group meetings again
- Joint Avista IRP page for gas and electric:  
<https://www.myavista.com/about-us/integrated-resource-planning>
  - TAC presentations
  - Documentation for IRP work
  - Past IRPs

# Virtual TAC Meeting Reminders

- Please mute mics unless speaking or asking a question
- Use the Skype chat box to write questions or comments or let us know you would like to say something
- Respect the pause
- Please try not to speak over the presenter or a speaker who is voicing a question or thought
- Remember to state your name before speaking for the note taker
- This is a public advisory meeting – presentations and comments will be recorded and documented

# Integrated Resource Planning

- Required by Idaho and Washington\* every other year
- Guides resource strategy over the next twenty + years
- Current and projected load & resource position
- Resource strategies under different future policies
  - Resource choices
  - Conservation measures and programs
  - Transmission and distribution integration for electric
  - Gas and electric market price forecasts
- Scenarios for uncertain future events and issues
- Key dates for modeling and IRP development are available in the Work Plans

# Technical Advisory Committee

- The public process piece of the IRP – input on what to study, how to study, and review of assumptions and results
- Wide range of participants involved in all or parts of the process
  - Ask questions
  - Help with soliciting new members
- Open forum while balancing need to get through all of the topics
- Welcome requests for studies or different assumptions.
  - **August 1, 2020** was the electric study request deadline for the 2021 IRP, new requests will be taken up in the 2023 IRP
- Planning team is available by email or phone for questions or comments outside of TAC meetings

# 2021 Electric IRP TAC Schedule

- TAC 1: Thursday, June 18, 2020
- TAC 2: Thursday, August 6, 2020 (Joint with Natural Gas TAC)
- TAC 2.5: Tuesday, August 18, 2020 Economic and Load Forecast
- TAC 3: Tuesday, September 29, 2020
- TAC 4: Tuesday, November 17, 2020
- TAC 4.5: Wednesday, December 16, 2020 – PRS & Scenarios
- **TAC 5: Thursday, January 21, 2021**
- Public Outreach Meeting: February 2021 (Do we still need this?)
- WUTC Public IRP Open Meeting: February 23, 2021
- TAC agendas, presentations, meeting minutes and IRP files available at:

<https://myavista.com/about-us/integrated-resource-planning>

# IRP Documentation Available

- Draft 2021 IRP
- Avista Resource Emissions Summary
- Load Forecast
- CPA Measures
- Avista 2020 Electric CPA – Summary and IRP Inputs
- Home Electrification Conversions
- Named Populations
- Natural Gas Prices
- Social Cost of Carbon
- High and Low Natural Gas Prices
- Market Modeling Results
- Climate Shift Scenario Inputs
- 2021 IRP New Resource Options
- 1 – Preferred Resource Strategy
- 2 – Baseline 1 No CETA Renewable Targets
- 3 – Baseline 2 No CETA Renewable Targets/SCC
- 4 – Baseline Portfolio 3 No Additions
- 5 – Clean Resource Plan (2027)
- 6 – Clean Resource Plan (2045)
- 7 – Social Cost of Carbon Idaho
- 8 & 9 – High and Low Load Forecasts
- 10 – RA Program
- 11 – 13 – Electrification 1, 2 & 3
- 14 – 2x SCC
- 15 – Colstrip Serves Idaho through 2025
- 16 – Colstrip Serves Idaho through 2035
- 17 – Colstrip Serves Idaho through 2045
- 18 – Clean Energy Delivery by Hour
- 19 – SCC on Net Power Supply
- 20 – Use Average Market for EE & SCC
- PRISM Draft Results (12/7/20)

# Process Updates

- January 4, 2021 – draft IRP released to TAC
- February 23, 2021 – WUTC hearing about draft IRP
  - Discussion about need for another public outreach meeting
- March 1, 2021 – Comments from TAC on draft IRP due
- March 2021 – final IRP editing, printing and compilation of Appendices
  - Inclusion of 2020 Renewable RFP results?
- April 1, 2021 – publication and submission of the 2021 Electric IRP with the Idaho and Washington Commissions
  - IRP and appendices will also be available on the Avista web site
- Commissions will schedule hearings and accept comments about 2021 IRP



# Today's TAC Agenda

- 9:00 Introductions, Lyons
- 9:15 Review Draft 2021 IRP, Lyons
- 9:45 Draft Resource Plans and Scenarios, Gall
- 10:45 2021 IRP Action Items, Lyons
- 11:30 Lunch
- 12:30 ARAM Model Overview, Gall
- 1:30 Break
- 1:45 Clean Energy Implementation Plan and Clean Energy Action Plan Discussion, Gall and Lyons
- 2:15 Draft IRP Comments from TAC
- 3:30 Adjourn



# 2021 Electric IRP Document Overview

John Lyons, Ph.D.  
Fifth Technical Advisory Committee Meeting  
January 21, 2021

# 2021 Electric IRP Chapters

1. Executive Summary
2. Introduction, IRP Requirements, and Stakeholder Involvement
3. Economic and Load Forecast
4. Existing Supply Resources
5. Energy Efficiency
6. Demand Response
7. Long-Term Position
8. Transmission & Distribution Planning
9. Supply-Side Resource Options
10. Market Analysis
11. Preferred Resource Strategy
12. Portfolio Scenarios
13. Energy Equity
14. Action Plan
15. Clean Energy Action Plan

# 2021 Electric IRP Chapters 1 – 3

- Chapter 1: Executive Summary
  - High level summary of 2021 IRP and PRS
- Chapter 2: Introduction, IRP Requirements, Stakeholder Involvement
  - TAC overview and rules guiding IRP development
  - Major changes from the 2017 and 2020 IRPs
- Chapter 3: Economic and Load Forecast
  - Economic conditions in Avista's service territory
  - Avista's energy and peak forecasts
  - Load forecast scenarios

# 2021 Electric IRP Chapters Ch. 4 – 6

- Chapter 4: Existing Supply Resources
  - Avista's resources
  - Contractual resources and obligations
  - Avista's natural gas pipeline rights overview
- Chapter 5: Energy Efficiency
  - Conservation Potential Assessment
  - Energy efficiency modeling and selection
- Chapter 6: Demand Response
  - Demand response potential study
  - Overview of past demand response pilot programs

# 2021 Electric IRP Chapters Ch. 7 – 8

- Chapter 7: Long-Term Position
  - Reliability adequacy and reserve margins
  - Resource requirements
  - Reserves and flexibility requirements
  
- Chapter 8: Transmission and Distribution Planning
  - Overview of Avista's Transmission System
  - Future Upgrades and Interconnections
  - Transmission Construction Costs and Integration
  - Merchant Transmission Plan
  - Overview of Avista's Distribution System
  - Future Upgrades and Interconnections (includes project evaluated with DER alternative)

# 2021 Electric IRP Chapters Ch. 9 – 10

- Chapter 9: Generation and Storage Resource Options
  - New resource option costs and operating characteristics
  - Potential Avista plant upgrades
- Chapter 10: Market Analysis
  - Fuel price forecasts
  - Regional resource additions
  - Regional greenhouse gas emissions forecast
  - Market price forecast
  - Scenario analysis

# 2021 Electric IRP Chapters Ch. 11 – 13

- Chapter 11: Preferred Resource Strategy
  - Resource Selection Process
  - Preferred Resource Strategy
  - Avoided cost
- Chapter 12: Portfolio Scenarios
  - Portfolio Scenarios
  - Portfolio cost, risk and environmental comparisons
- Chapter 13: Energy Equity
  - Vulnerable populations
  - Highly impacted communities
  - Equity Advisory Group



# 2021 Electric IRP Chapters Ch. 14 – 15

- Chapter 14: Action Plan
  - Progress made on Action Items from the 2017 and 2020 IRPs
  - IRP projects identified for the 2023 IRP
- Chapter 15: Clean Energy Action Plan
  - Action items for CETA compliance between this and the 2023 IRPs



# 2021 Electric Integrated Resource Plan Overview

James Gall, Electric IRP Manager  
Fifth Technical Advisory Meeting, 2021 IRP  
January 21, 2021

# Planning Environment

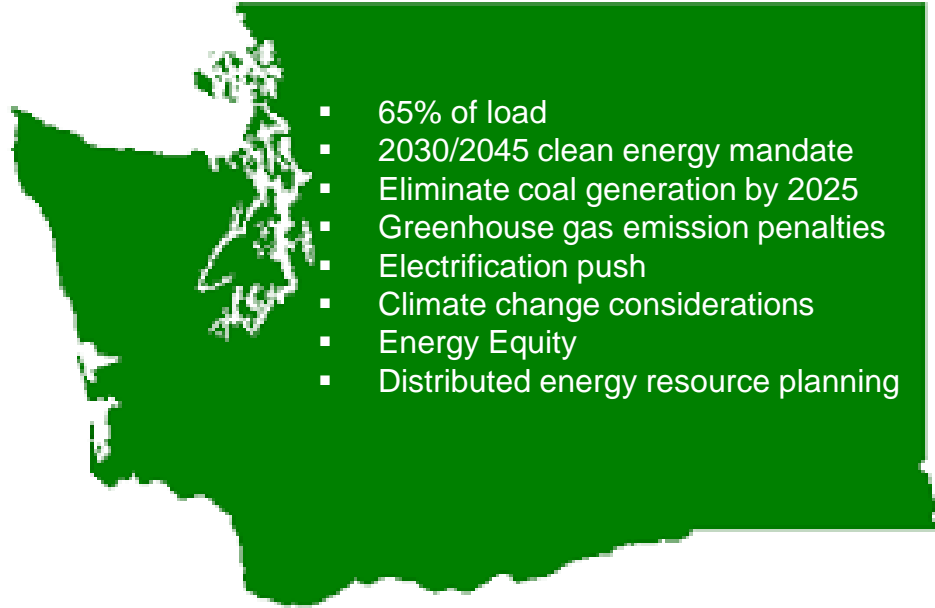

- 65% of load
- 2030/2045 clean energy mandate
- Eliminate coal generation by 2025
- Greenhouse gas emission penalties
- Electrification push
- Climate change considerations
- Energy Equity
- Distributed energy resource planning



- Market effects
- State policy on Avista's resources

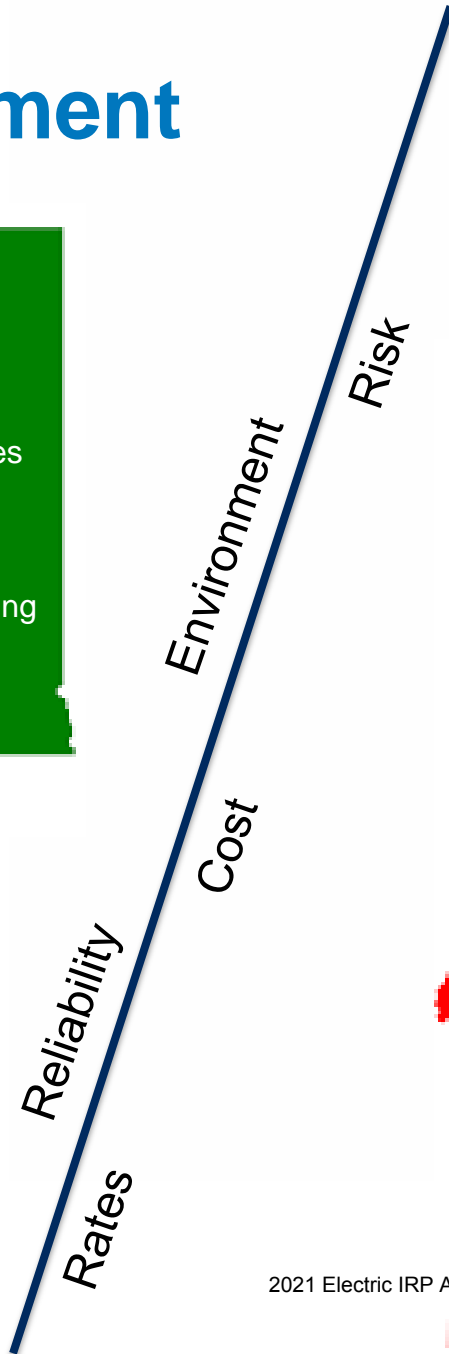
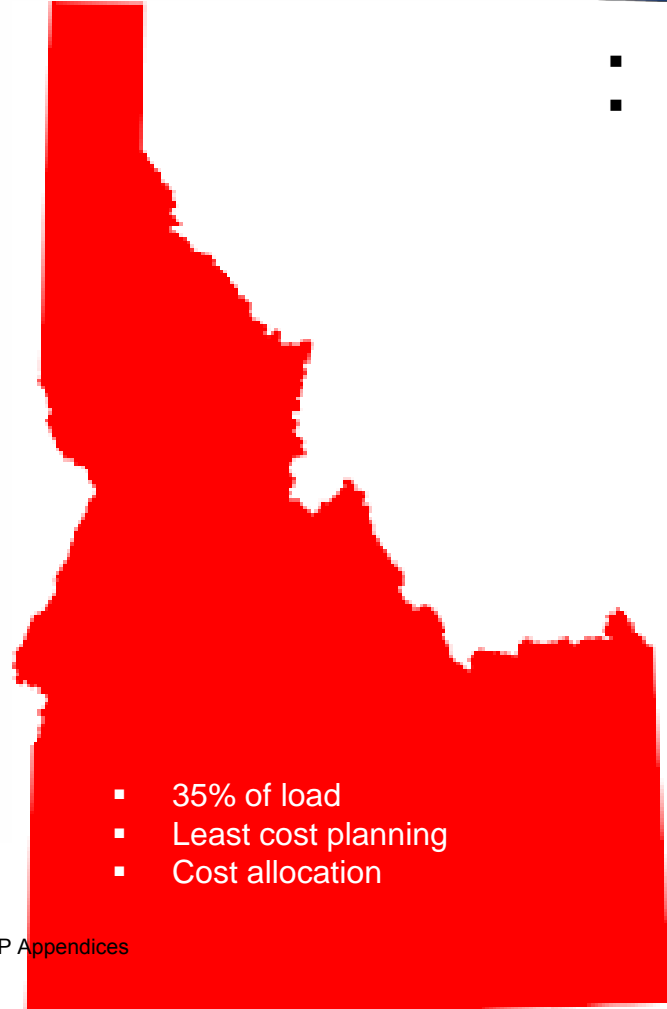



- 35% of load
- Least cost planning
- Cost allocation

# Avista Reliability Needs

- Meet average coldest day’s peak hour load, required reserves, and a 16% planning margin.
  - Maintain 5 percent Loss of Load Probability.
  - Regional effort to “pool” resources by creating resource adequacy market may lower resource need.
- ~300 MW needed Nov-2026 (expiration of Lancaster PPA)
  - Additional 200 MW by 2036
- Aging Infrastructure & state policy pressuring existing resources to close:
  - Colstrip: 2025 (WA)
  - Northeast CT: 2035
  - Boulder Park: 2040
  - Coyote Springs 2 CCCT/Rathdrum CTs ???
- Load growth & changes
  - 0.3% annual average growth.
  - Large potential increases with electrification.
  - Climate change might lower winter and increase summer peak growth. (required study in next IRP)

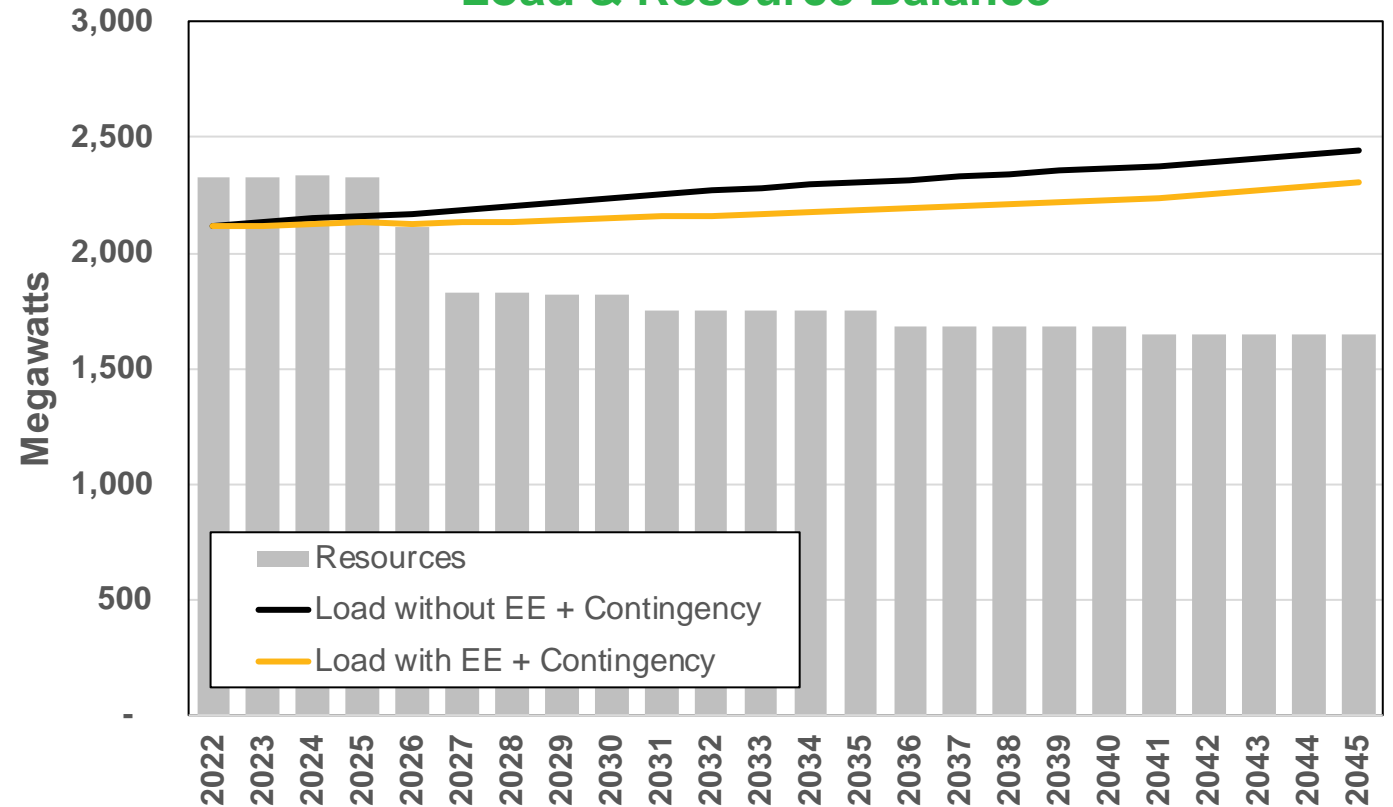
## System Winter Peak Hour Load & Resource Balance



# Washington Clean Energy Requirements

- Avista must create glidepath to 2030 clean energy requirements.
- By 2030, 100% of “net” Washington retail sales must “use” clean energy.
  - 20% can be met with unbundled RECs.
  - might require real-time clean energy delivery.
- Resource Allocation
  - Washington customers “buy” Idaho clean energy share.
    - Assumes Idaho’s wind/biomass may be sold to WA without limitation.
    - Assumes Idaho’s hydro purchases limited to 20% of sales beginning in 2030, then declining.
- By 2045, 100% of Washington sales must be served with clean energy.
  - May require real-time clean energy delivery.

## Washington Retail Sales & Clean Resource Balance

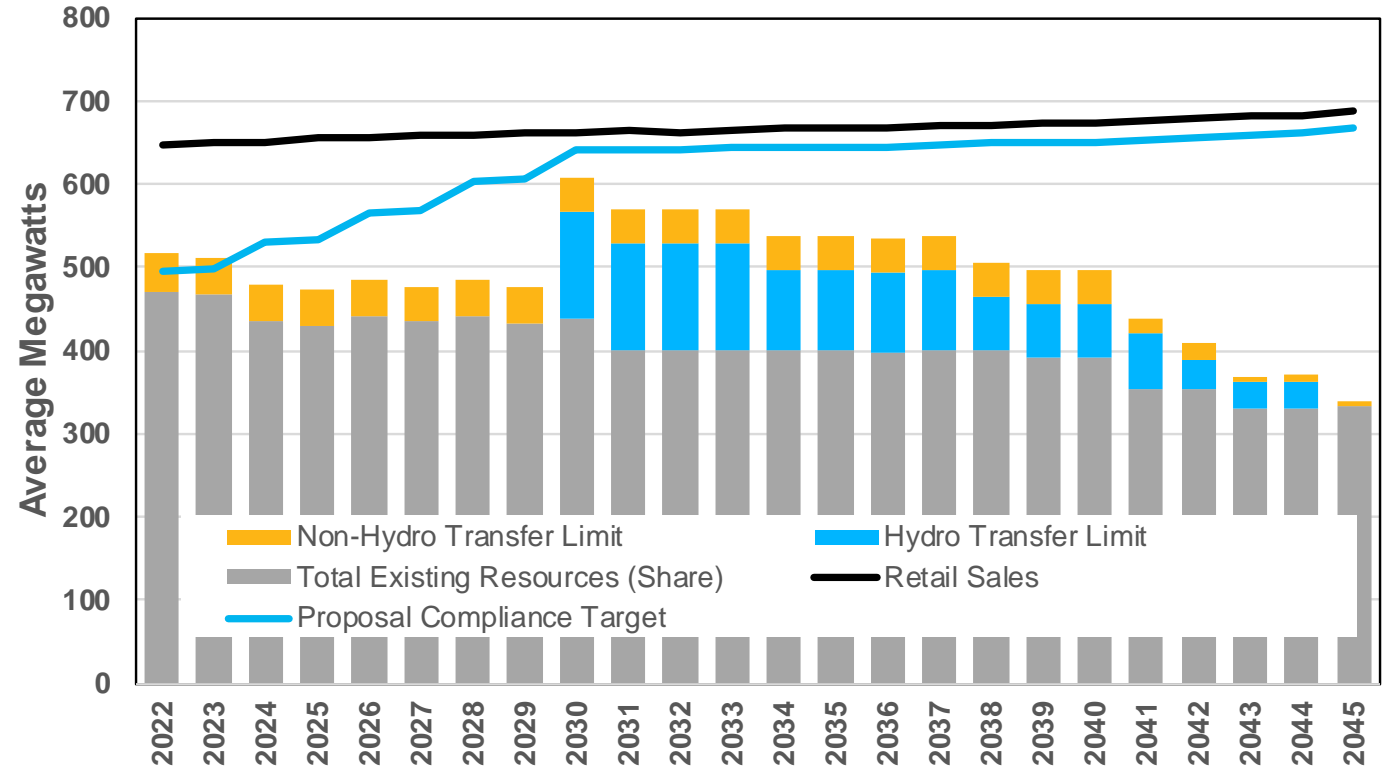

# Avista's Clean Energy Targets

- In 2022, Avista generates clean energy equal to 75% of retail sales.
- To meet 100% clean energy by 2027, Avista must acquire ~320 aMW.
  - 800-1,000 MW of wind or 1,800 MW solar (DC).
- Increases to over 510 aMW by 2045.
  - Driven by load growth and expiring contracts
- Avista goal is 100% real-time clean energy delivery by 2045.
  - Requires substantial investments in energy storage to meet winter loads.
  - Electrification of space & water heating compound these issues.

## System Annual Average Sales & Clean Resource Balance

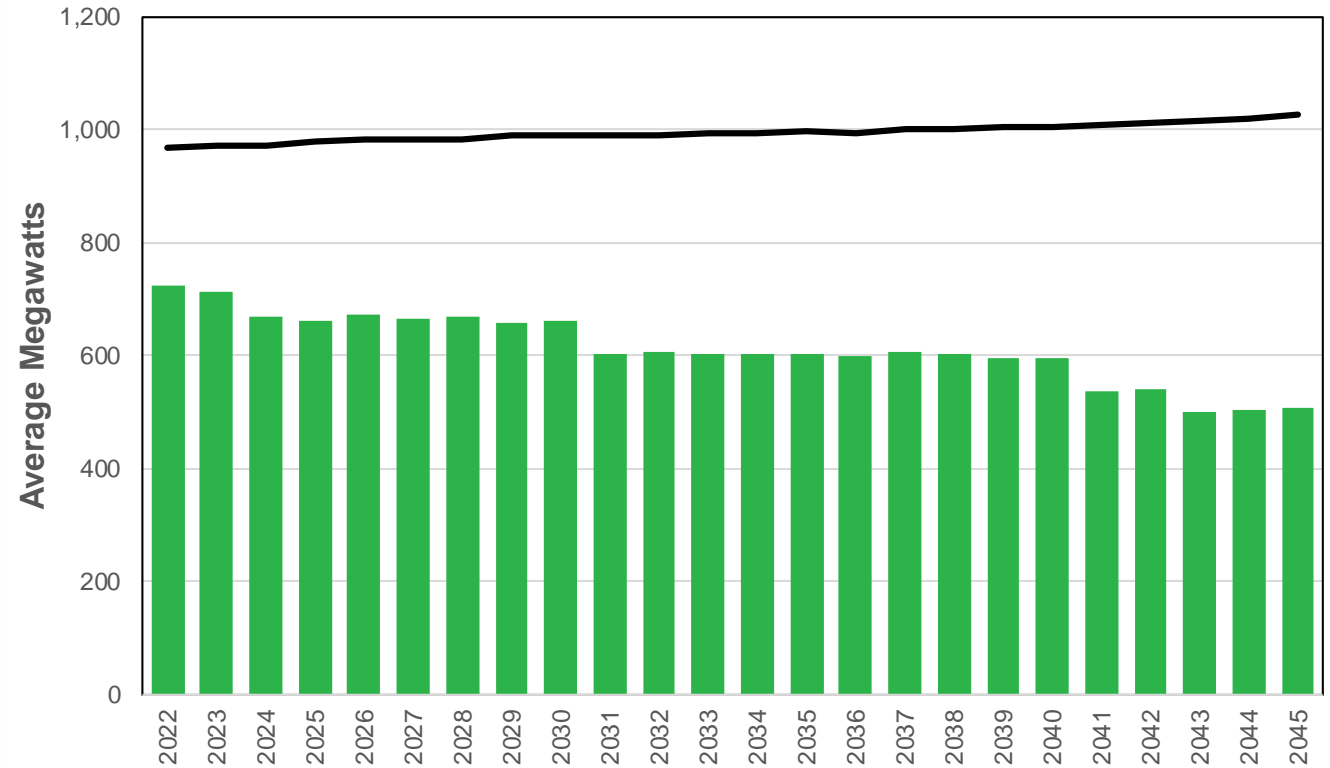

# Resource Options

- Multiple factors drive resource selection
  - Cost or price
  - Clean vs. fossil fuel
  - Capacity value or “peak credit”
  - Storage vs. energy production
  - Location
  - Availability (new vs. existing)
- Resource retirements
  - Future capital investment
  - Operating & maintenance cost/availability
  - Fuel availability
  - Carbon pricing risk

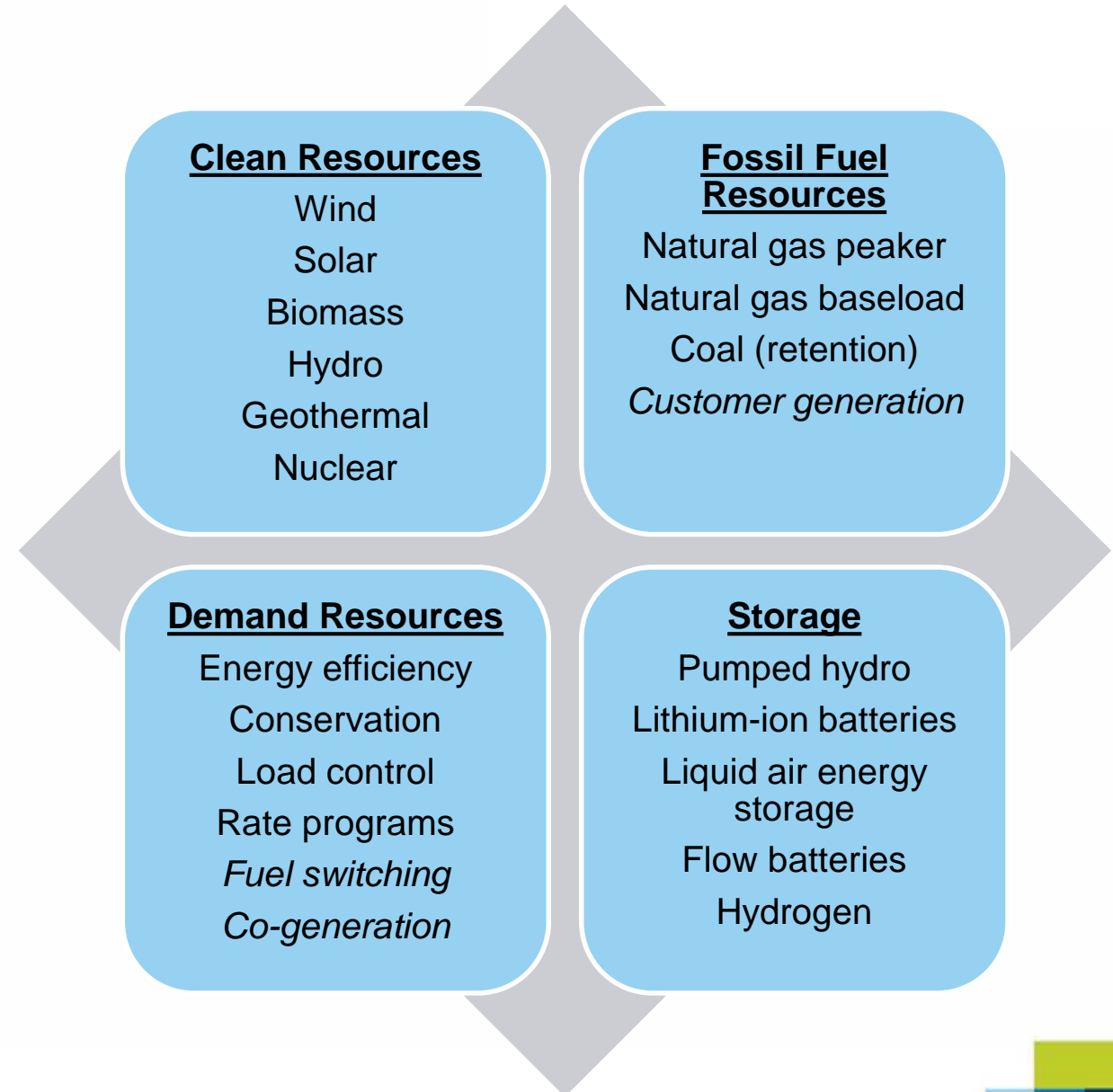

## IRP's Preferred Resource Strategy - Supply Resources

- IRP focuses on state goals and system reliability to find lowest reasonable cost to serve customer load.
- Develop resource needs assessment for each state.
  - State policies drive resource choices.
  - Cost allocation based on state policies.
  - Rate forecasts.
- Does not include resources in current RFP.
- Limits existing resources acquisition to 75 MW of additional regional hydro after 2031.
- Resources are selected either as system resource (65%/35%) or state resource.
- Resources economically or contractually expected to leave the Avista resource mix are in green, natural gas-fired are in orange, energy storage are in blue and clean resources are in black.

## Supply-Side Resource Changes

Resource Type	Year	State	Capability (MW)
Colstrip	2021	System	(222)
Montana wind	2023	WA	100
Montana wind	2024	WA	100
Lancaster	2026	System	(257)
Kettle Falls upgrade	2026	System	12
Natural gas peaker	2027	ID	85
Natural gas peaker	2027	System	126
Montana wind	2028	WA	100
NW Hydro Slice	2031	WA	75
Rathdrum CT upgrade	2035	System	5
Northeast	2035	System	(54)
Natural gas peaker	2036	System	87
Solar w/ storage	2038	System	100
4-hr storage for solar	2038	System	50
Boulder Park	2040	System	(25)
Natural gas peaker	2041	ID	36
Montana wind	2041	WA	100
Solar w/ storage	2042-2043	WA	239
4-hr storage for solar	2042-2043	WA	119
Liquid air energy storage	2044	WA	12
Liquid air energy storage	2045	ID	10
Solar w/ storage	2045	WA	149
4-hr storage for solar	2045	WA	75
Supply-side resource net total (MW)			1,024
Supply-side resource total additions (MW)			1,581



# IRP's Preferred Resource Strategy - Demand Resources

- 63% of EE programs are C&I.
- 77% of EE savings are from Washington.
- Washington avoided cost are \$106/MWh plus \$151/kW-year for capacity.
  - Driven by social cost of carbon and clean energy avoided costs.
- Idaho avoided cost are \$30/MWh plus \$137/kW-year for capacity.
- EE reduces winter peak by a 101% ratio to energy savings and 97% ratio for summer.
- Washington 2022-23 target is 89,000 MWh; 50% higher than previous biennium and higher than the IRP's two year cost effective acquisition amount.
- 10-year target is 651 GWh or 74 aMW.
- Time of use and variable peak pricing requires significant rate design effort leveraging metering infrastructure.
- Demand response has limited reliability benefits due to duration and call limitations.

## Energy Efficiency End Use Targets

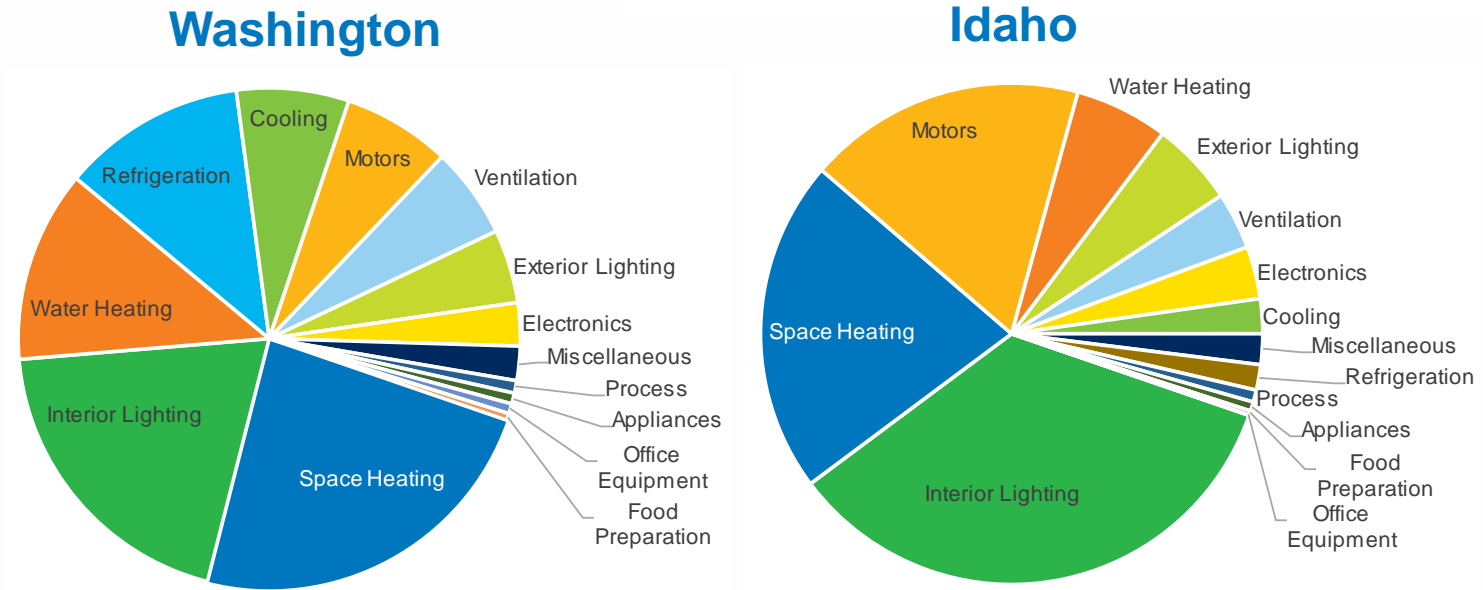

## Demand Response

Program	Washington	Idaho
Time of Use Rates	2 MW (2024)	2 MW (2024)
Variable Peak Pricing	7 MW (2024)	6 MW (2024)
Large C&I Program	25 MW (2027)	n/a
DLC Smart Thermostats	7 MW (2031)	n/a
Third Party Contracts	14 MW (2032)	8 MW (2024)
Behavioral	1 MW (2041)	n/a
<b>Total</b>	<b>56 MW</b>	<b>15 MW</b>

# Preferred Resource Strategy Costs and Rates

- Existing and new costs are allocated between the states Avista serves.
- Washington rates are ~1 cent (12%) higher per kWh today.
  - Spread increases to 1.7 cents (15%) by 2030 and 2.0 cents by 2035.\*
- Power costs rise well above inflation over first 8 years due to clean energy and capacity additions.

\* Non-power related cost such as non-generation transmission, distribution, and administration, are not directly modeled in the IRP and assume a 2% annual growth rate.

## Overall Energy Rates

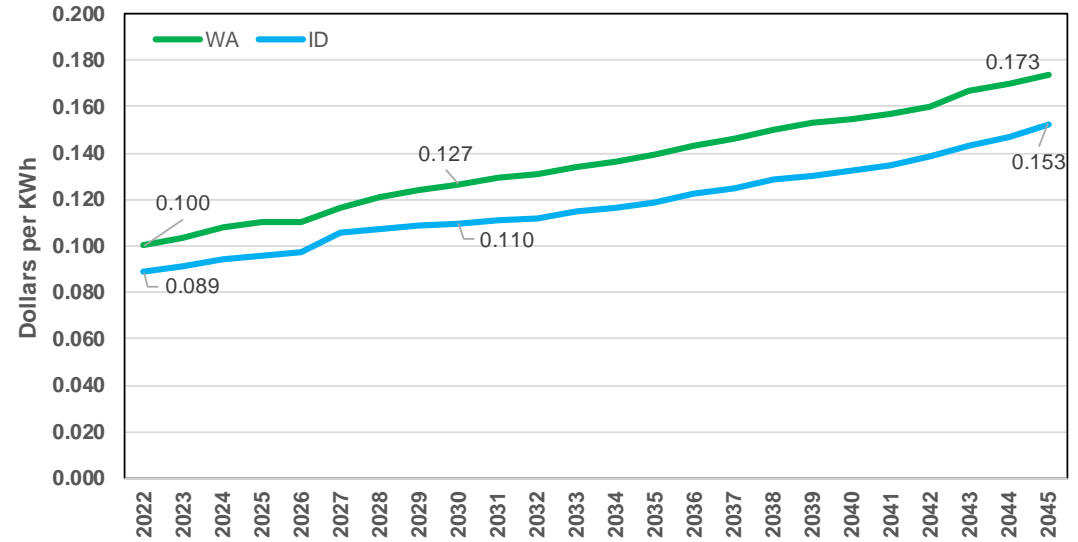

## Power Cost Rate Change

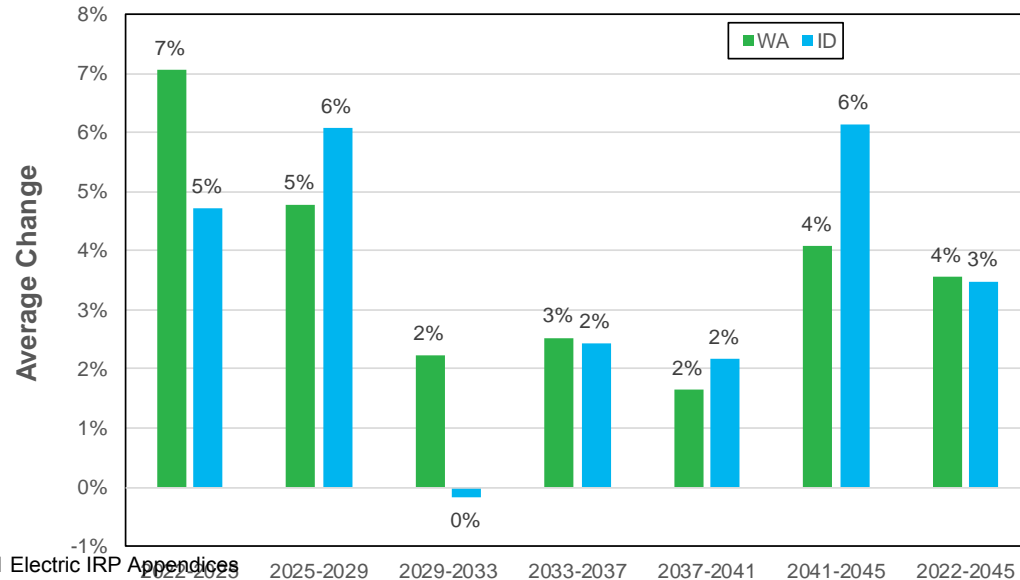

# Clean Energy Shares (aMW)

- By 2030, Washington customers will have clean energy equal to 100 percent of its retail sales.
- Idaho’s clean energy share will lower both Idaho and Washington rates.
  - 46% clean by 2030 and 60% clean by 2045.
- Clean energy as percent of system sales increase to 78% by 2027 and 86% by 2045.
- Short-term clean energy purchase may increase these estimates.
- Avista could purchase RECs to meet 2027 goals.
- Idaho customers have opportunity to sell excess hydro RECs to reduce rates.

## Clean Energy Forecast

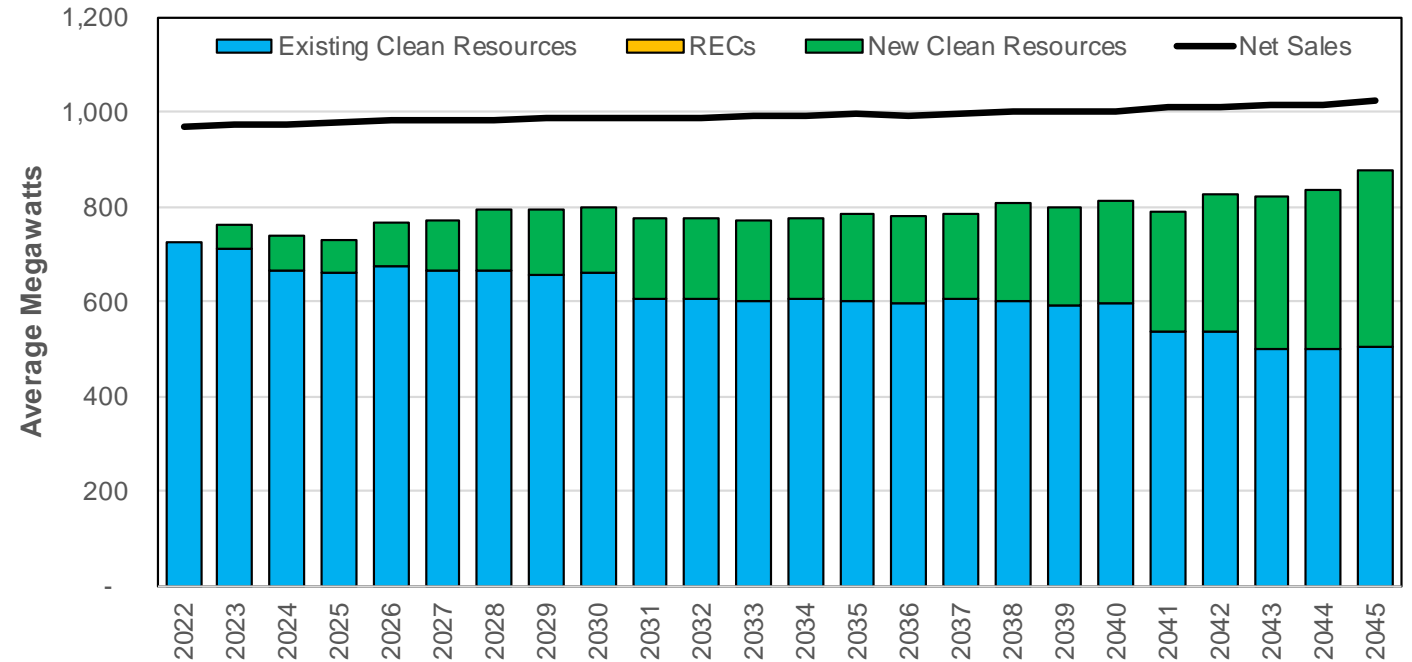

# Greenhouse Gas Emissions Forecast

- 2020 emissions were ~2.7 million metric tons.
- Colstrip responsible for >1 million tons.
  - Colstrip emissions would fall regardless as the plant dispatch decreases over time.
- By 2030, emissions fall by 76 percent.
- Emissions from natural gas upstream operations and construction are included in this IRP.
  - Washington load portion includes these emissions priced at the social cost of carbon.
  - WUTC recently ruled these emissions accounting is encouraged but not required.
- Net emissions include market purchases and sales at the regional emission intensity rate.

## Annual Greenhouse Gas Types

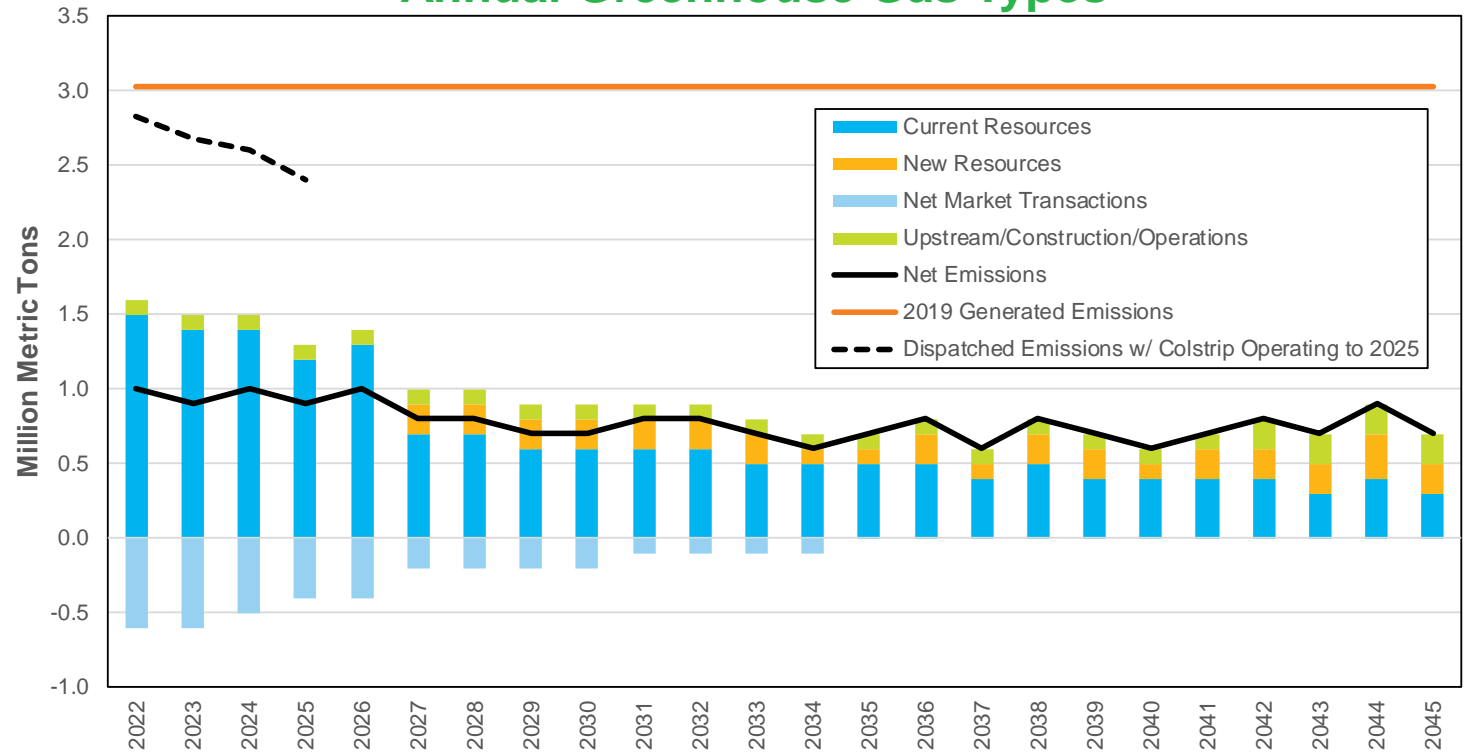

# IRP Insights given uncertainty

- WUTC’s rulemaking regarding “use” of energy may require significant market transformation and require additional clean and storage resources.
- Electrification of Washington’s space and water heat will significantly increase winter peak (up to ~700 MW) and annual energy (155 aMW) needs.
  - New winter load will require significant investment in winter capacity- such as natural gas turbines or long-duration storage.
  - Energy rates from power acquisition rise 8% excluding non-power costs such as T&D and home owner costs.
- Water heater load control may offer opportunities if program costs decline (55+ MW).
  - AC control is low cost option if summer peaks significantly increase.
  - Electric vehicle control is cost prohibitive now, but costs are falling.
- Hydrogen-fired turbines show potential to be lowest overall cost resource to serve winter loads in a 2045 100% clean energy future.
  - Liquid air energy storage (LAES) and pumped hydro are better nearer term options with intermediate energy duration options.
  - Lithium-ion is low cost when coupled with solar or need for short durations.
- A regional resource adequacy program is needed to address regional reliability risk and lower Avista’s new resource needs and costs (<1%).
  - Resource mix could favor solar and hydro.
- Retaining Colstrip through 2025 increases cost by 1%.
  - Tradeoff is higher power cost risk with an early exit.
- Meeting the clean energy goals increases total cost by 5%.
  - Idaho rates are 10% higher in 2027/ 28% higher in 2045.
  - Washington rates are 4% higher in 2027/ 20% higher in 2045.
- Energy equity public engagement in Washington may lead to new programs, resources, or investments.
  - Equity budget requirements and limitations are unknown.
- Climate change (warmer temperatures) reduces power costs and resource needs
  - Hydro runoff better matches winter peaks and spill is less.
- Policy requirements with high carbon “taxes” support higher clean energy levels and conservation investments.

# Highlights

## From the Preferred Resource Strategy

- Avista needs new clean resources to comply with CETA.
- New capacity resources are required to maintain reliability.
- Avista will need to pursue demand response, rate design, and increase energy efficiency.
- Exiting Colstrip is economic, but higher risk.
- Long-duration storage is critical to meeting 100% clean energy objectives.

## From Scenario Analysis

- Climate change lowers power costs.
- State/national policies will increase both rates and costs.
- Electrification will significantly increase power supply requirements. T&D and homeowner costs are not estimated at this time.
- Real-time clean energy delivery will be challenging for industry and current market structure.
- Meeting Avista's clean energy goals will be a challenge without new technology or increasing rates.



# Extra Slides

Tables & figures from Draft IRP of potential interest

# Scenario Analysis

Sorted by System PVRR (highest to lowest)

Scenario	System-PVRR (\$ Bill)	WA-PVRR (\$ Bill)	ID-PVRR (\$ Bill)	WA 2030 Rate (\$/kWh)	WA 2045 Rate (\$/kWh)	ID 2030 Rate (\$/kWh)	ID 2045 Rate (\$/kWh)	2030 Stdev (\$ Mill)	2045 Stdev (\$ Mill)	2045 Tail Risk (\$ Mill)	2045 GHG Emissions (MT)
11- Electrification 1	14.7	10.1	4.5	0.131	0.188	0.109	0.158	34	88	132	0.57
13- Electrification 3	14.4	9.9	4.5	0.128	0.181	0.109	0.158	34	85	129	0.57
12- Electrification 2	14.0	9.5	4.5	0.127	0.176	0.109	0.155	34	71	115	0.56
6- Clean Resource Plan (2045)	13.9	9.0	5.0	0.130	0.209	0.122	0.196	25	35	48	0.00
18- Clean Energy Delivered Each Hr	13.7	9.2	4.6	0.127	0.207	0.110	0.155	40	115	162	0.50
5- Clean Resource Plan (2027)	13.7	8.8	4.9	0.129	0.176	0.121	0.166	24	56	100	0.50
9- High Load Forecast	13.5	8.9	4.6	0.123	0.164	0.104	0.142	38	70	122	0.56
7- SCC Idaho	13.3	8.7	4.6	0.126	0.175	0.112	0.161	39	82	143	0.50
17- Colstrip Exit 2045	13.3	8.7	4.6	0.127	0.173	0.108	0.154	34	72	127	0.89
16- Colstrip Exit 2035	13.3	8.7	4.6	0.127	0.174	0.108	0.153	34	85	148	0.53
19- SCC on Net P/S	13.3	8.7	4.6	0.126	0.174	0.110	0.153	40	84	148	0.54
15- Colstrip Exit 2025	13.3	8.7	4.6	0.127	0.173	0.110	0.153	40	87	150	0.54
14- 2x SCC	13.3	8.7	4.5	0.127	0.174	0.110	0.152	40	85	147	0.53
1- Preferred Resource Strategy	13.2	8.7	4.5	0.127	0.173	0.110	0.153	40	87	150	0.54
20- Use Avg Mrkt for EE SCC	13.2	8.7	4.5	0.126	0.172	0.108	0.153	40	88	154	0.54
10- RA Market	13.2	8.7	4.5	0.126	0.174	0.109	0.152	43	94	171	0.50
8- Low Load Forecast	13.1	8.6	4.5	0.130	0.186	0.113	0.163	44	101	178	0.48
3- Baseline 2	13.0	8.4	4.6	0.121	0.168	0.110	0.151	55	148	253	0.56
2- Baseline 1	13.0	8.4	4.6	0.121	0.168	0.110	0.152	54	148	254	0.56
4- Baseline 3	12.5	8.1	4.4	0.117	0.158	0.106	0.141	55	162	276	0.33



# Quantitative Risk

# PVRR + PV TailVar95 Risk

## 2030 Standard Deviation vs Levelized Revenue Requirement

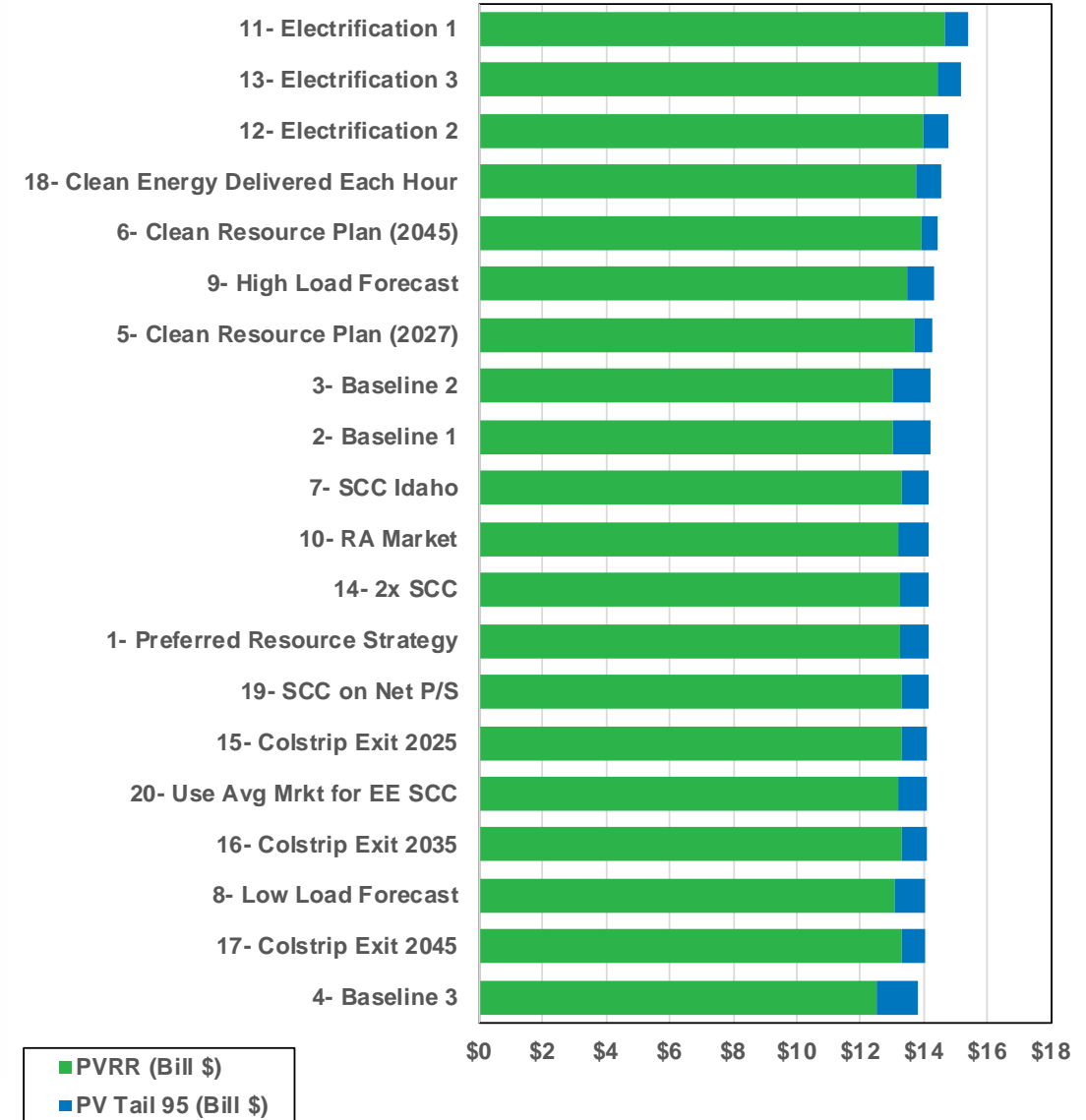
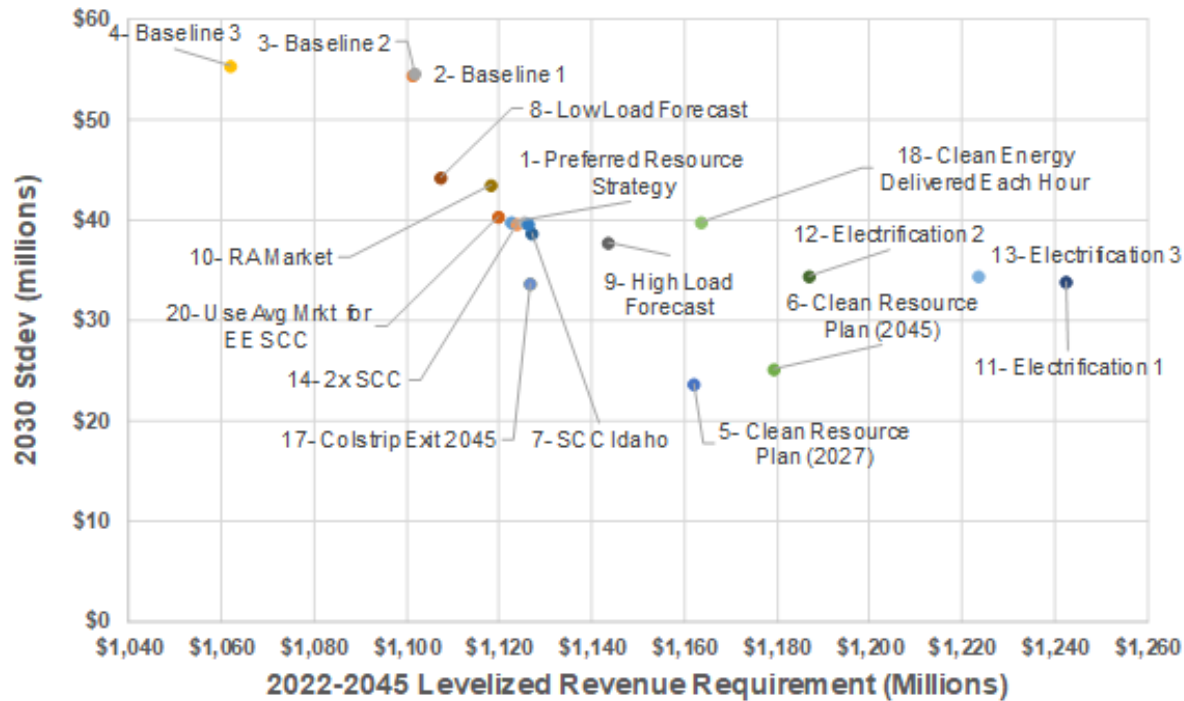

■ PVRR (Bill \$)  
■ PV Tail 95 (Bill \$)

# Avoided Costs

Year	Energy Flat (MWh)	Energy On-Peak (MWh)	Energy Off-Peak (MWh)	Clean Premium (MWh)	Capacity (\$/kW-Yr)
2022	\$20.37	\$21.66	\$18.65	\$0.00	\$0.00
2023	\$18.71	\$19.34	\$17.89	\$13.27	\$0.00
2024	\$18.73	\$19.04	\$18.32	\$13.54	\$0.00
2025	\$19.99	\$20.05	\$19.92	\$13.81	\$0.00
2026	\$23.74	\$23.68	\$23.82	\$14.09	\$0.00
2027	\$24.63	\$24.27	\$25.12	\$14.37	\$115.10
2028	\$25.67	\$24.99	\$26.58	\$14.65	\$117.40
2029	\$26.65	\$25.77	\$27.83	\$14.95	\$119.80
2030	\$26.46	\$25.48	\$27.78	\$15.25	\$122.20
2031	\$27.63	\$26.48	\$29.15	\$15.55	\$124.60
2032	\$28.02	\$26.86	\$29.57	\$15.86	\$127.10
2033	\$29.30	\$27.96	\$31.08	\$16.18	\$129.70
2034	\$29.42	\$27.98	\$31.33	\$16.50	\$132.20
2035	\$30.47	\$28.81	\$32.68	\$16.83	\$134.90
2036	\$32.10	\$30.38	\$34.41	\$17.17	\$137.60
2037	\$31.95	\$30.08	\$34.45	\$17.51	\$140.30
2038	\$34.46	\$32.26	\$37.39	\$17.86	\$143.10
2039	\$34.77	\$32.31	\$38.04	\$18.22	\$146.00
2040	\$35.67	\$33.15	\$39.01	\$18.58	\$148.90
2041	\$38.23	\$35.77	\$41.52	\$18.96	\$151.90
2042	\$38.71	\$36.40	\$41.79	\$19.34	\$154.90
2043	\$39.27	\$36.92	\$42.40	\$19.72	\$158.00
2044	\$46.82	\$44.18	\$50.34	\$20.12	\$161.20
2045	\$46.45	\$44.31	\$49.28	\$20.52	\$164.40
<b>20 yr Levelized</b>	<b>\$25.85</b>	<b>\$25.20</b>	<b>\$26.72</b>	<b>\$14.04</b>	<b>\$80.3</b>
<b>24 yr Levelized</b>	<b>\$27.18</b>	<b>\$26.39</b>	<b>\$28.22</b>	<b>\$14.50</b>	<b>\$86.6</b>

2021 Electric IRP Appendices

# PRS Greenhouse Gas Intensity

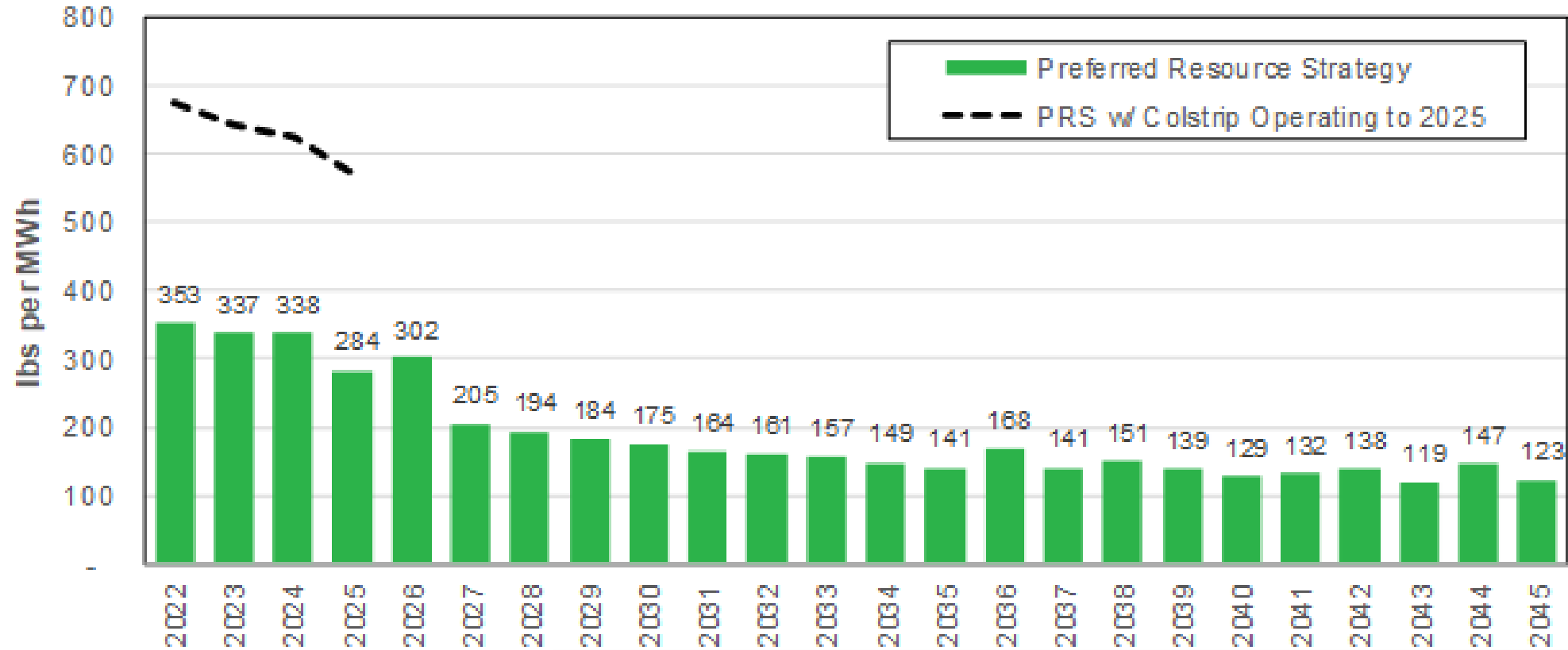

# Initial Vulnerable Population Areas

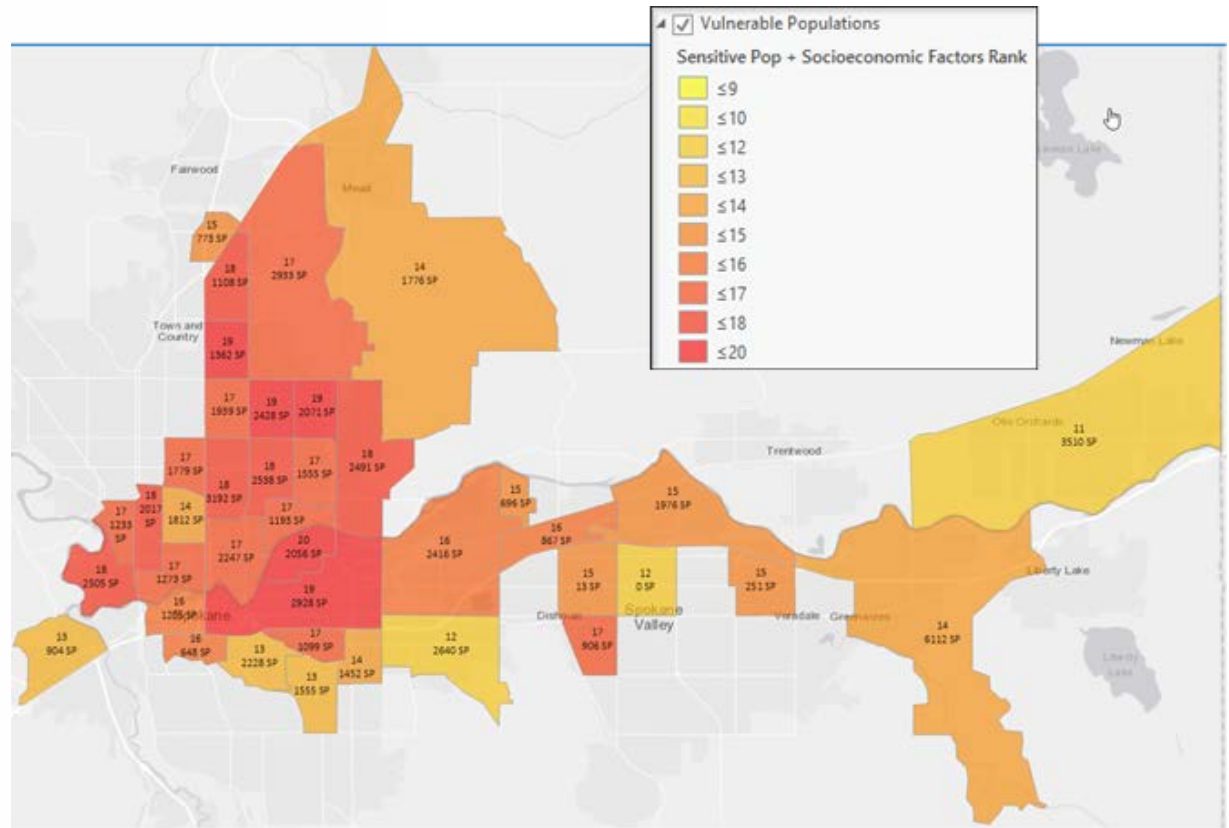
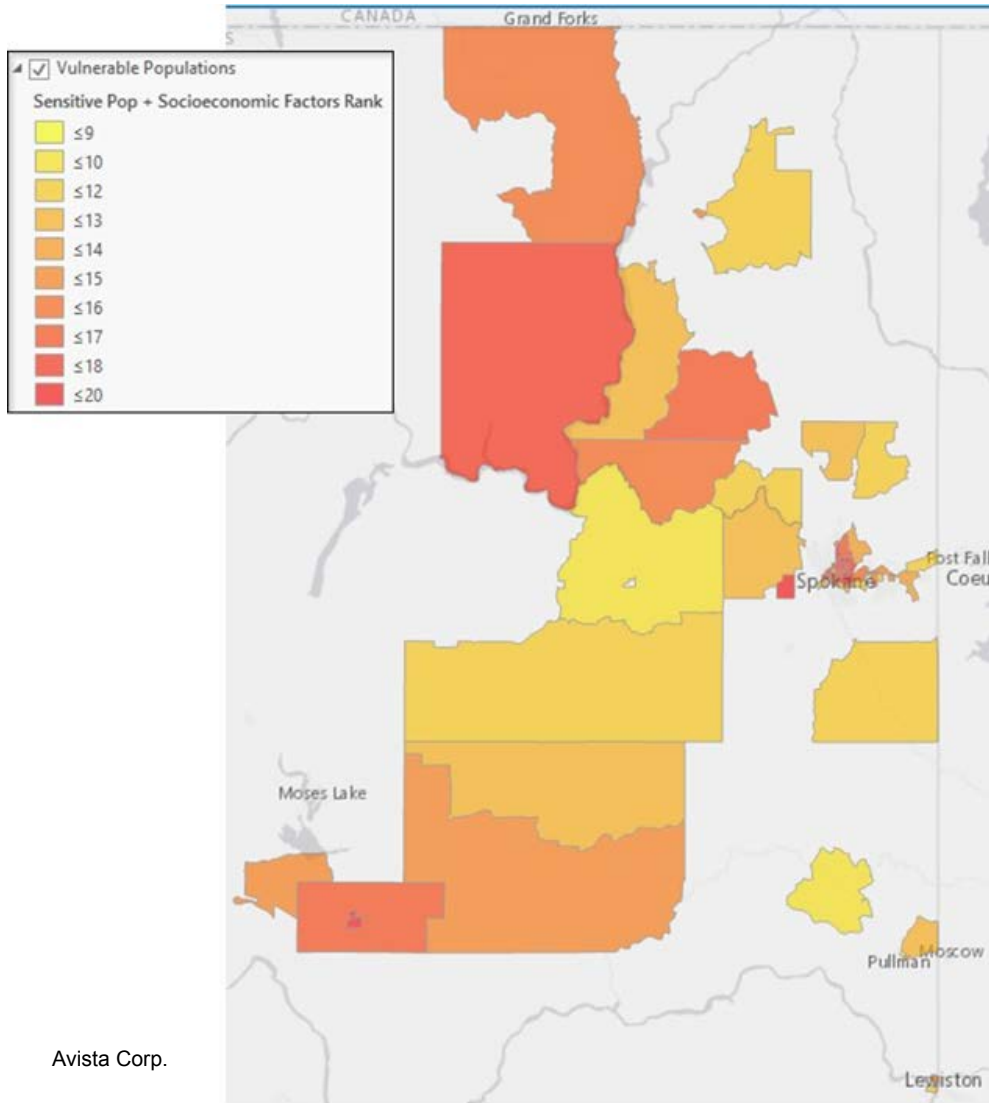

# Energy Forecast

Economic Growth	Average Annual Native Load Growth (percent)
Expected Case	0.30
High Growth	0.70
Low Growth	-0.10

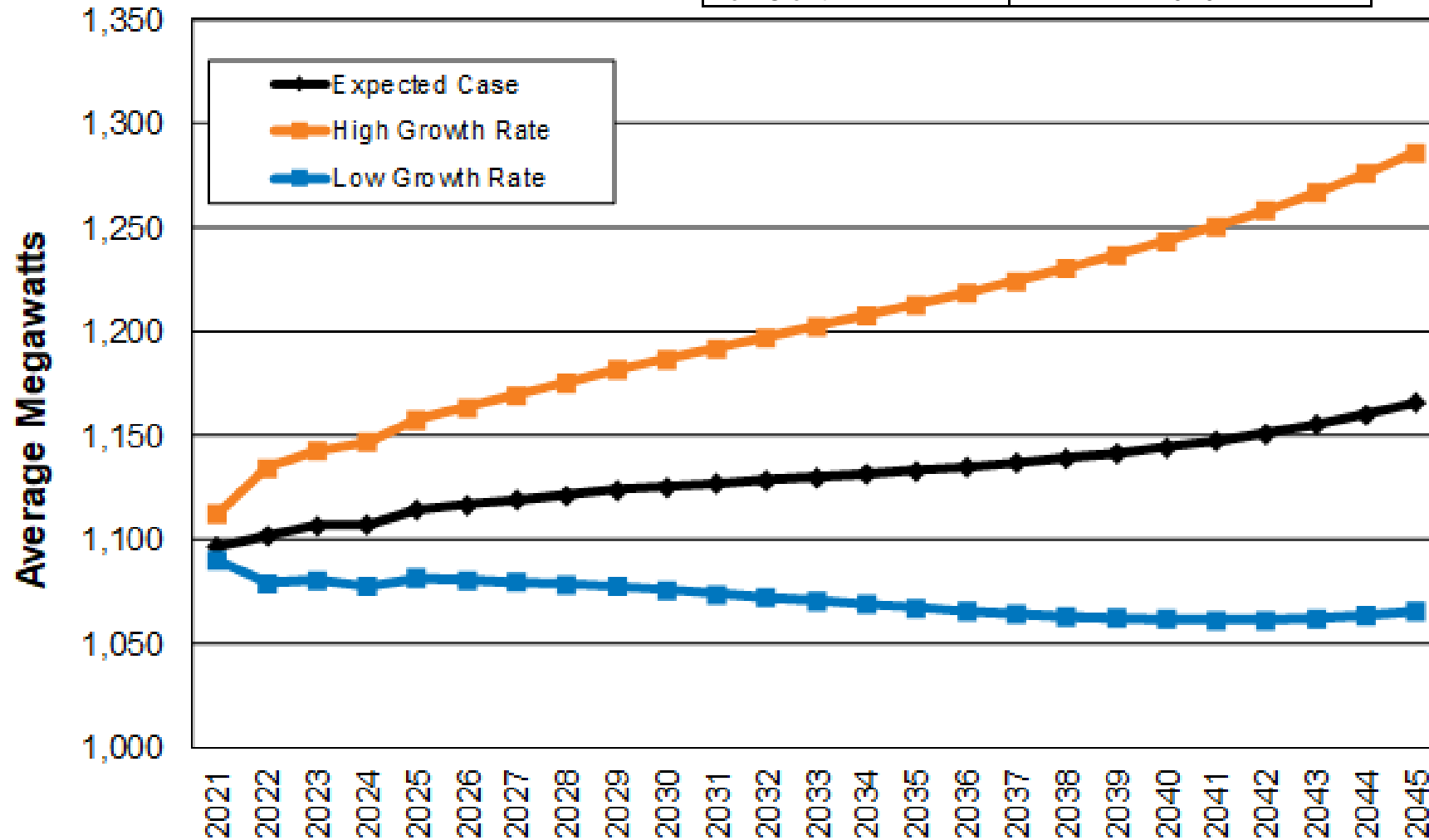



# 2021 Electric IRP Action Items

John Lyons, Ph.D.  
Fifth Technical Advisory Committee Meeting  
January 21, 2021

# Summary of 2017 IRP Action Plan

- Generation Resource Related Analysis
  - Continue to review existing facilities for opportunities to upgrade capacity and efficiency
  - Model specific commercially available storage technologies
  - Upgrade the TAC concerning the EIM study and Avista's plan of action
  - Monitor regional winter and summer resource adequacy, additional LOLP studies
  - Post Falls redevelopment update
  - Ancillary services valuation for storage and peaking technologies using intra hour modeling capabilities
  - Monitor state and federal environmental policies affecting Avista's generation fleet
- Energy Efficiency and Demand Response
  - Consider moving T&D benefits from historical to forward looking values
  - Decide on potential and cost study for winter and summer residential DR programs
  - Use the UCT methodology for Idaho energy efficiency programs
  - Share list of energy efficiency measures with TAC prior to CPA completion

# Summary of 2017 IRP Action Plan

- Transmission and Distribution Planning
  - Maintain existing Avista transmission rights
  - Continued participation in BPA transmission rate proceedings
  - Participate in regional and sub-regional efforts to expand transmission system
  - Coordinate IRP and T&D planning to evaluate alternative technologies to solve T&D constraints



# 2020 Resource Acquisition Action Items

- Determine plan for Long Lake expansion and file with appropriate agencies concerning if the project meets CETA and licensing issues
- Continued pursuit of pumped storage opportunities
- Conduct transmission network and air permitting studies for contingency CTs if pumped hydro is not available
- 2020 RFP for renewable energy capacity (2022-2023 online)
- 2021 RFP for capacity resources (on-line by 2026)
- Additional studies for the eventual shutdown of Northeast CT in 2035

# 2020 Analytical & Process Action Items

- Continued study of costs of intermittent resources, and financial costs and capabilities of different resources to meet the variability
- Include greenhouse gas emissions from resource construction, manufacturing and operations
- Investigate third-party market price forecast for use with future IRPs
- Participate in CETA rulemaking
- Participate in development of regional resource adequacy program

# 2021 IRP Action Items

- Continue 2020 Action Items with shortened 2021 IRP
- Investigate consultant for hydro and load shift from climate
- Investigate integration of resource dispatch, resource selection and reliability verification functions in IRP modeling
- Study natural gas supply issues and options for Kettle Falls CT
- Determine if distribution planning should be separate process
- Form an Equity Advisory Group
- Conduct existing resource market potential estimate of amount and timing of existing resources through 2045
- Additional DR peak credit analysis
- Partner with a third-party to identify NEI benefits



# 2021 Electric IRP Modeling Process Overview

James Gall, IRP Manager  
Fifth Technical Advisory Committee Meeting  
January 21, 2021

# IRP Planning Models

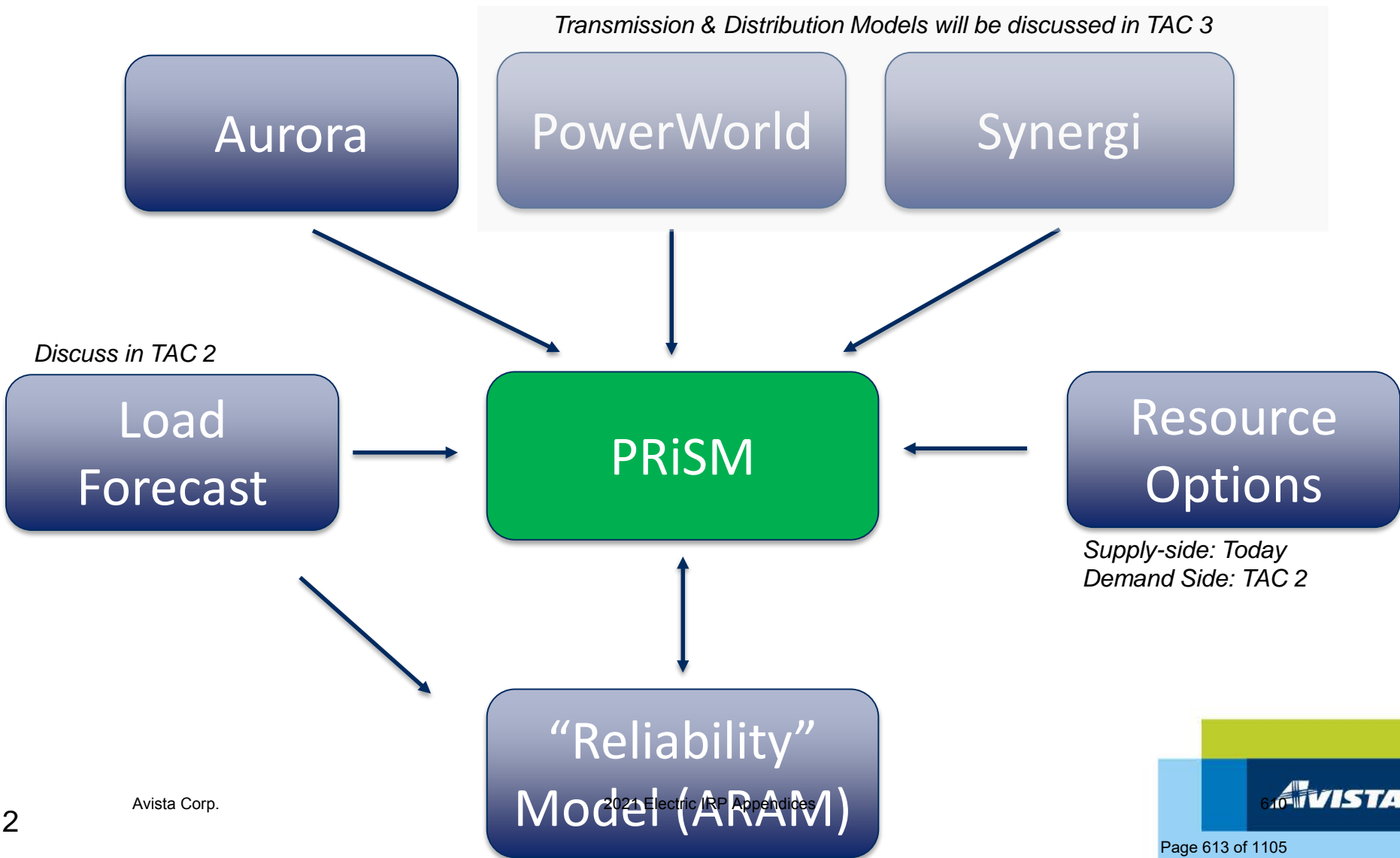

# What is Reliability Planning

- Estimate the probability of failure to serve all load
  - Avista's reliability target is 95% of all simulations serve 100% of load and reserve requirements
- Model randomizes events
  - Hydro, weather (load, wind, resource capacity), forced outages
- Typically large sample size 1,000 simulations
- Can be used to validate if a portfolio is reliable
  - Estimate the required planning reserve margin (PRM)
  - May be used to estimate peak credits for new resources (ELCC)
- Gold standard: regional wide program with enforced requirements to each utility
  - Set required methodology, planning margin, and resource contribution based on regional model

# 2021 IRP Table 7.1: LOLP Reliability Study Results without New Resources

Month	2025 with Colstrip	2025 without Colstrip	2030	2040
Jan	0.6%	2.7%	10.5%	32.7%
Feb	0.1%	0.6%	4.2%	15.0%
Mar	0.0%	0.0%	0.5%	2.9%
Apr	0.0%	0.0%	0.0%	0.0%
May	0.0%	0.0%	0.0%	0.0%
Jun	0.0%	0.0%	0.0%	0.1%
Jul	0.0%	0.3%	1.7%	33.0%
Aug	0.0%	0.1%	0.6%	30.5%
Sep	0.0%	0.0%	0.0%	0.9%
Oct	0.0%	0.0%	0.0%	0.5%
Nov	0.0%	0.0%	0.7%	5.0%
Dec	0.8%	3.2%	7.1%	17.1%
Annual	1.4%	6.3%	21.2%	81.4%

# Table 11.5: Reliability Metrics of PRS

Year	2025 (PRS)	2030 (PRS)	2040 (PRS)	2030 (333 MW NG)
LOLP	4.6%	5.4%	8.8%	5.2%
LOLH	1.45 hours	1.74 hours	2.89 hours	1.89 hours
LOLE	0.12	0.14	0.21	0.15
EUE	233 MWh	266 MWh	548 MWh	316 MWh
Total Events	126	148	228	160



# Scenario Analysis

- Due to limited time, focus on scenarios with reliability implications
- Any other scenario we should look at?

#	Scenario	Year Studied	LOLP	LOLH	LOLE	EUE
1	PRS	2030	5.4%	1.74	0.14	266
5	Clean Resource Plan (2027)	2030	5.7%	1.66	0.13	250
6	Clean Resource Plan (2045)	2040	7.5%	2.98	0.22	643
10	Resource Adequacy Program	2030	6.4%	2.67	0.2	510
16	Colstrip Exit 2035	2030	5.7%	1.77	0.14	287
11	Electrification Scenario 1	2040	TBD	TBD	TBD	TBD



# 2021 Electric IRP Clean Energy Action Plan

John Lyons, Ph.D.  
Fifth Technical Advisory Committee Meeting  
January 21, 2021

# Clean Energy Action Plan

The CEAP must:

1. identify and be informed by the utility's ten-year cost-effective conservation potential assessment;
  2. if applicable, establish a resource adequacy requirement;
  3. identify the potential cost-effective demand response and load management programs that may be acquired;
  4. identify renewable resources, non-emitting electric generation and distributed energy resources that may be acquired and evaluate how each identified resource may be expected to contribute to meeting the utility's resource adequacy requirement;
  5. identify any need to develop new, or expand or upgrade existing bulk transmission and distribution facilities; and identify the nature and possible extent to which the utility may need to rely on alternative compliance options, if appropriate.
- CEAP is available in chapter 15 of the 2021 IRP

# Energy Efficiency Savings

Figure 15.1: Washington 10-year Energy Efficiency Target

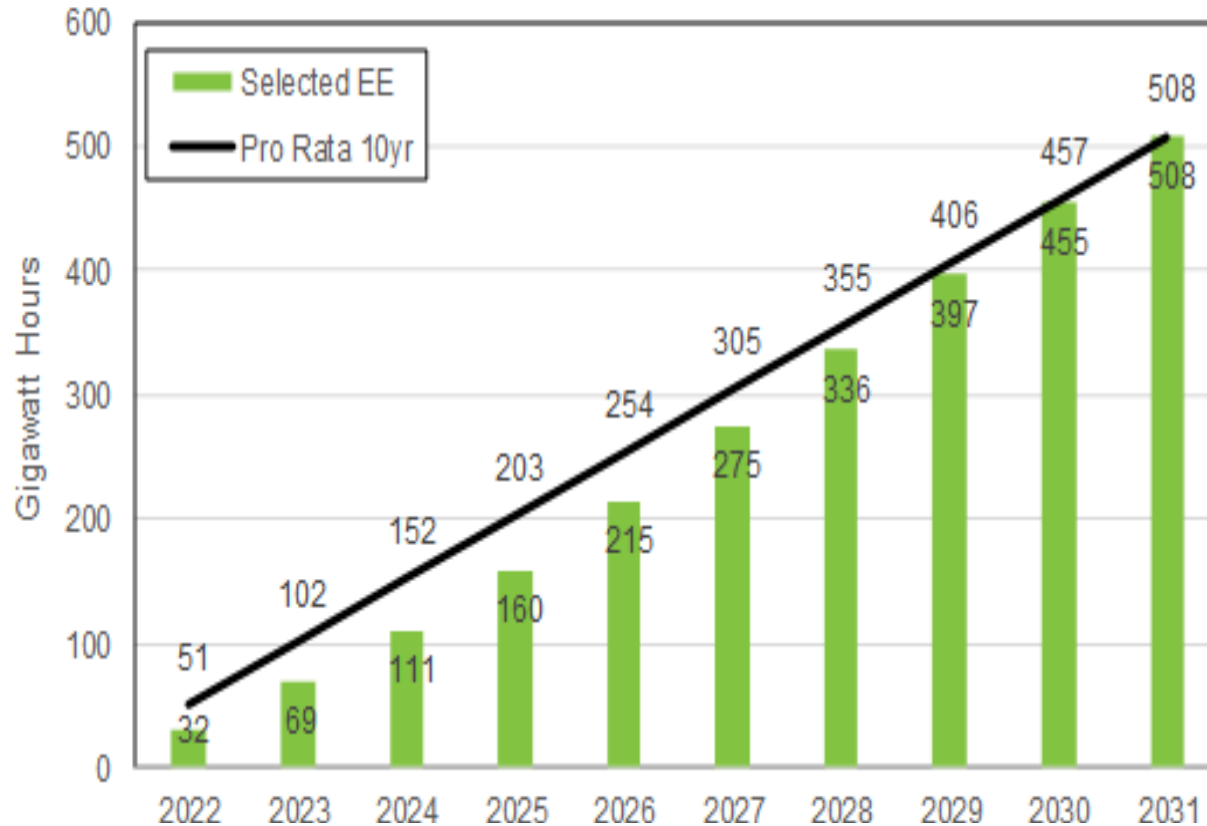

- 508 GWh of cumulative energy efficiency or 61.3 aMW with T&D line losses.
- Reduce winter peak 64.3 MW and summer peak 69.5 MW.

# Resource Adequacy

- Participating in development of a regional resource adequacy program.
  - 16 percent winter peak and 7 percent summer peak planning margins, plus operating reserves and regulation requirements.
  - A resource adequacy program could reduce Avista's new capacity needs by up to 70 MW in 2031 based on the current draft program design.
  - Could reduce future resource acquisitions if successfully implemented.
- 2021 IRP identifies 83 MW of natural gas-fired capacity for Washington by November 1, 2026 to replace Lancaster PPA and maintain reliability.
- Future RFP may identify a lower cost clean resource.

# Demand Response and Load Management Programs

**Table 15.1: Demand Response and Load Management Programs**

Program	Washington
Time of Use Rates	3.1 MW (2024)
Variable Peak Pricing	8.9 MW (2024)
Large C&I Program	25.0 MW (2027)
DLC Smart Thermostats	0.6 MW (2031)
Total	37.6 MW (2031 Total)

- CEAP identifies new programs with the potential to reduce load by 37.6 MW by 2031.
- Begin in 2024 with time of use and variable peak pricing opt-in programs, estimated to be 12 MW by 2031.
- 25 MW large commercial customer program offering is likely before the Lancaster PPA ends in 2026.
- Heating and cooling program starts in 2031 with 0.6 MW of savings and grows to over 6 MW by 2045.
- Future RFPs may identify other DR opportunities.

# Planned Clean Energy Acquisitions

**Table 15.2: 2022-2031 Washington Clean Energy Targets (aMW)**

	2022	2023	2024	2025	2026	2027	2028	2029	2030	2031
Retail Sales	647	650	651	655	657	658	658	661	662	663
PURPA	22	22	22	22	22	22	22	22	22	22
Solar Select	6	6	6	6	6	6	0	0	0	0
<b>Net Requirement</b>	<b>619</b>	<b>623</b>	<b>624</b>	<b>628</b>	<b>629</b>	<b>631</b>	<b>636</b>	<b>640</b>	<b>641</b>	<b>642</b>
Target Clean %	80	80	85	85	90	90	95	95	100	100
<b>Clean Energy Goal</b>	<b>496</b>	<b>498</b>	<b>530</b>	<b>534</b>	<b>567</b>	<b>568</b>	<b>604</b>	<b>608</b>	<b>641</b>	<b>642</b>
Owned Hydro	292	288	288	285	292	289	292	289	291	291
Contract Hydro	96	95	65	66	65	64	63	58	59	23
Kettle Falls	24	23	23	21	23	21	22	20	21	19
Palouse Wind	24	24	24	24	24	24	24	24	24	24
Rattlesnake Flat Wind	36	36	36	36	36	36	36	36	36	36
Adams Neilson Solar	0	0	0	0	0	0	6	6	6	6
<b>Available Resources</b>	<b>473</b>	<b>466</b>	<b>436</b>	<b>431</b>	<b>439</b>	<b>434</b>	<b>441</b>	<b>433</b>	<b>436</b>	<b>399</b>
<b>Shortfall</b>	<b>23</b>	<b>33</b>	<b>94</b>	<b>103</b>	<b>127</b>	<b>134</b>	<b>163</b>	<b>174</b>	<b>204</b>	<b>242</b>
<b>Resource Forecast</b>										
Montana Wind	0	48	96	96	96	96	144	144	144	144
Kettle Falls Upgrade	0	0	0	0	6	6	6	6	5	5
Regional Hydro	0	0	0	0	0	0	0	0	0	31
ID AVA Ren. Purchase	23	0	0	7	25	32	13	25	42	41
ID AVA Hydro Purchase	0	0	0	0	0	0	0	0	13	21
<b>Total Energy/RECs</b>	<b>23</b>	<b>48</b>	<b>96</b>	<b>103</b>	<b>127</b>	<b>134</b>	<b>163</b>	<b>175</b>	<b>204</b>	<b>242</b>
<b>Net Position</b>	<b>0</b>	<b>15</b>	<b>2</b>	<b>0</b>	<b>0</b>	<b>0</b>	<b>0</b>	<b>1</b>	<b>0</b>	<b>0</b>
<b>Total Clean Resource Need</b>	<b>23</b>	<b>48</b>	<b>96</b>	<b>103</b>	<b>127</b>	<b>134</b>	<b>163</b>	<b>175</b>	<b>191</b>	<b>180</b>

# Transmission & Distribution Improvements

- 2021 IRP did not identify any significant transmission or distribution improvements.
- Future transmission investment follows the 10-year plan in Appendix G.
- Two interconnection requests to Avista transmission to evaluate up to 200 MW in Rathdrum and additional capacity at Kettle Falls.
  - Kettle Falls interconnection request does not require any significant improvements.
  - Rathdrum results will not be available until later in 2021.
- Reviewed potential resource acquisitions that could defer distribution investments, but none were selected in this IRP.
- Will begin designing a public process for distribution planning in 2021.



# Energy Equity

- Developing plan for equitable distribution of benefits and reduced burdens on highly impacted communities and vulnerable populations.
- Washington is identifying highly impacted communities and guidance on cost premiums.
  - Avista developed methodology to identify vulnerable populations and will finalize after forming Equity Advisory Group (EAG) in 2021.
  - EAG will guide determination of communities and help design outreach and engagement to distinguish and prioritize indicators and solutions.
  - Committed to energy efficiency program pilot for vulnerable populations starting in 2021.
- Enhancements to energy efficiency cost effectiveness test include non-energy benefits.
- Avista prioritizes efficiency projects to improve resiliency and increase energy security in these communities and gives a preference to renewable projects in vulnerable areas.
- Future request for proposals may yield more beneficial renewable resources.

# Cost Analysis

- IRP compares PRS cost to baseline portfolio without CETA requirements to show if alternative compliance (2% cost cap) will be required.
- Avista expects to be below cap by \$64 and \$61 million for first two of the four-year compliance periods.

**Table 15.3: 2022-2024 Washington Cost Cap Analysis (millions \$)**

	2021	2022	2023	2024	2025	Total
Revenue Requirement w/ SCC	651	651	669	700	705	
Baseline		650	657	672	678	
Annual Delta		1	11	28	27	67
Percent Change		0.2%	1.7%	4.2%	4.0%	2.5%
<b>Four Year Max Spending</b>		33	33	33	33	132
Comparison vs Annualized Cost Cap		(32)	(22)	(5)	(6)	(64)

**Table 15.4: 2025-2028 Washington Cost Cap Analysis (millions \$)**

	2024	2025	2026	2027	2028	Total
Revenue Requirement w/ SCC	705	714	718	744	755	
Baseline		688	709	721	731	
Annual Delta		26	9	23	23	81
Percent Change		3.8%	1.3%	3.2%	3.2%	2.9%
<b>Four Year Max Spending</b>		36	36	36	36	143
Comparison vs Annualized Cost Cap		(10)	(27)	(13)	(12)	(61)



# 2021 Electric IRP Clean Energy Implementation Plan (CEIP)

James Gall, Electric IRP Manager  
Fifth Technical Advisory Meeting  
January 21, 2021

# CEIP Overview

- File by October 1, 2021. (draft by Aug 15, 2021)
- Include current clean energy mix (2020).
- Set targets for energy efficiency, demand response and clean energy acquisition using median hydro conditions.
- Include an assessment of indicators of Highly Impacted Communities and Vulnerable Populations through work with the Equity Advisory Group.
- Include specific actions the utility will make to meet clean energy goals; including resource adequacy and equity considerations.
- Calculate incremental costs.
- Create public participation plan (due on May 1, 2021).
- Interested parties have 60 days to provide written comments to the Commission.
- Commission will set an open public meeting; after adjudication, Commission will approve, reject or approve with condition the utility's CEIP or CEIP update.

# Public Participation

- A public participation plan must be filed with the WUTC on May 1, 2021.
- Avista will begin public participation on the CEIP toward the end of May 2021.
- All TAC members are welcome to join; please contact John Lyons at [john.lyons@avistacorp.com](mailto:john.lyons@avistacorp.com) or 509-495-8515 to be on the CEIP email list.
- Equity Advisory Group is currently forming.
  - Ana Matthews leads this effort
  - Contact her at 509-495-7979 or [ana.matthews@avistacorp.com](mailto:ana.matthews@avistacorp.com) for more information



# Clean Energy Implementation Plan (CEIP) Details of Requirements

# WAC 480-100-640

## CEIP Content – Filing Requirements, Interim Targets

1. Utility must file with the commission a CEIP by **October 1, 2021**, and every four years thereafter; must describe the utility's plan for making progress toward meeting the clean energy transformation standards
2. Interim targets.
  - a) Utility must propose a series of interim targets that
    - i. Demonstrate utility's reasonable progress toward meeting the standards.
    - ii. Consistent with WAC 480-100-610 (4).
      - EE, DR, Safety, Reliability, Balancing system, Equity
    - iii. Interim targets must be proposed in the form of the percent of forecasted retail sales of electricity supplied by nonemitting and renewable resources prior to 2030 and from 2030-2045
  - b) Must include utility's percentage of retail sales of electricity supplies by nonemitting and renewable resources in 2020 in the first CEIP it files.
  - c) Each interim target must be informed by the utility's historic performance under median water conditions

### 3) CEIP Content – Specific Targets

- a) Utility must specific targets for energy efficiency, demand response and renewable energy.
  - i. EE target must encompass all other EE and conservation targets and goals required by the Commission; must be described in the BCP; utility must provide forecasted distribution of energy and nonenergy costs and benefits
  - ii. Must provide proposed program details, budget, measurement and verification protocols, target calculations, forecasted distribution of energy and nonenergy costs and benefits for the utility's demand response target.
  - iii. Must propose the renewable energy target as a percent of retail sales of electricity supplied by renewable resources, details of renewable energy projects or programs, budgets, forecasted distribution of energy and nonenergy costs and benefits
- b) Must provide description of technologies, data collection, processes, procedures and assumptions used to develop targets



## 4) CEIP Content – Customer Benefit Data

- a) Identify highly impacted communities using the cumulative impact analysis pursuant to RCW 19.405.140 combined with census tracts (Indian country).
- b) Identify vulnerable populations based on adverse socioeconomic and sensitivity factors developed through the Equity Advisory Group (EAG) process and public participation plan; describe changes from the utility's most recently approved CEIP.
- c) Include proposed or updated customer benefit indicators and associated weighting factors related to WAC 480-100-610(4)(c) such as energy benefits, nonenergy benefits, reduction of burdens, public health, environment, reduction in cost, energy security and resiliency. Customer benefit indicators and weighting factors must be developed consistent with the EAG process and public participation; describe any changes from the most recently approved CEIP.

## 5) CEIP Content – Specific Actions

Include specific actions the utility will take over the implementation period; actions must meet and be consistent with the clean energy transformation standards and be based on the utility's CEAP and interim/specific targets; specific action items must be presented in a tabular format providing

- a) General location, if applicable, proposed timing, estimated cost, whether resource will be located in a highly impacted community, will be governed by, serve or benefit highly impacted communities or vulnerable populations in part or in whole.
- b) Metrics related to the RA including contributions to capacity or energy needs.
- c) Customer benefit indicator values, or a designation as nonapplicable, for every customer benefit indicator described in section (4) (c)

## 6) CEIP Content – Narrative Description of Specific Actions

CEIP must describe how the specific actions:

- a) Demonstrate progress toward meeting the standards.
- b) Demonstrate consistency with the standards in 480-100-610(4)
  - i. An assessment of current benefits and burdens on customers, by location and population, and the projected impact of specific actions on the distribution of customer benefits and burdens during the implementation period.
  - ii. Description of how the specific actions in the CEIP mitigate risks to highly impacted communities and vulnerable populations and are consistent with the longer-term strategies and actions described in the utility's most recent IRP and CEAP
- c) Consistent with proposed interim and specific targets;
- d) Consistent with the IRP;
- e) Consistent with the resource adequacy requirements and a narrative describing how the resources identified in the most recent RA assessment conducted or adopted by the utility demonstrates that the utility will meet its RA standard;

## 6) CEIP Content – Narrative Description of Specific Actions (continued)

- f) Demonstrate how the utility is planning to meet the clean energy transformation standards at the lowest reasonable cost such as
  - i. Utility's approach to identifying lowest cost portfolio of specific actions that meet the requirements as well as its methodology for weighting considerations
  - ii. Utility's methodology for selecting the investments and expenses it plans to make over the next 4 years that are directly related to the utility's compliance with clean energy transformation standards and demonstrate investments represent a portfolio approach to investment plan optimization
  - iii. Supporting documentation justifying each specific action identified in the CEIP

# CEIP Content

7. Include a projected incremental cost as outline in WAC 480-100-660 (4).
8. Detail the extent of TAC/EAG or other public participation in the development of the CEIP.
9. Describe any utility plans to rely on alternative compliance mechanisms as described in RCW 19.405.040 (1) (b)
10. If the utility proposes to take the early action coal credit, it must satisfy the requirements in that statutory provision by
  - Demonstrate the proposed action constitutes early action by presenting the analysis by detailing with and without the proposed early action
  - Compare both the proposed early action and the alternative against the same proposed interim and specific targets

# 11) CEIP Content – Biennial CEIP Update

- Utility must make a biennial CEIP update filing on or before November 1 of each odd-numbered year that the utility does not file a CEIP.
- CEIP update may be limited to the BCP requirements.
- Must file its biennial CEIP update in the same docket as its most recently filed CEIP and include an explanation of how the update will modify targets in its CEIP.
- Utility may file in the update other proposed changes to the CEIP as a result of the IRP progress report.

# 480-100-645

## CEIP Review Process

1. Interested parties may file written comments with the Commission within 60 days of the utility's filing.
2. Commission will set an open public meeting; after adjudication, Commission will approve, reject or approve with condition the utility's CEIP or CEIP update; Commission may order, recommend or require more stringent targets.
  - a) Commission may adjust or expedite interim or specific target timelines.
  - b) Parties requesting the commission make existing targets more stringent or adjust the existing timelines has the burden of demonstrating the utility can achieve the targets or timelines.

## 2021 Electric IRP TAC 5 Meeting Notes, January 21, 2021

**Meeting Attendees:** Andres Alvarez; Shawn Bonfield, Avista; Annette Brandon, Avista; Terrence Browne, Avista; Corey Dahl; Thomas Dempsey, Avista; Grant Forsyth, Avista; Annie Gannon, Avista; Amanda Ghering, Avista; Dainee Gibson-Webb, Idaho Conservation League; Michael Gump, Avista; James Gall, Avista; Lori Hermanson, Avista; Fred Heutte, NEWC; Clint Kalich, Avista; Kevin Keyt, IPUC; Scott Kinney, Avista; John Lyons, Avista; Jaime Majure, Avista; James McDougall, Avista; Ben Otto, Idaho Conservation League; Tom Pardee, Avista; Lance Kaufman (AWEC); Marissa Warren, Idaho Office of Energy Resources; Michael Eldred, IPUC; Mike Louis, IPUC; Mike Morrison, IPUC; Montoya Lina; Morgan Brummell; Rachel Farnsworth, IPUC; Shay Bauman; Jennifer Snyder, WUTC; Terri Carlock, IPUC; Tina Jayaweera, NW Power Council; Yao Yin, IPUC; Chip Estes; Joni Bosh, NWEA; Katie Pegan; Katie Ware.

Notes in *italics* are responses made by the presenter.

### Introductions and 2021 IRP Process Updates, John Lyons

**John Lyons (slide 6):** Is the public open meeting that is scheduled for February 2021 still needed now that we have an open public meeting at the WUTC on February 23, 2021?

**Rachel Farnsworth:** What was going to be covered in the public outreach meeting? *Probably a high level overview of the draft IRP and an opportunity for the public to comment before publishing it.* I'm not sure I agree with not having that public meeting, but will discuss it with our Idaho team. There was a lot of interest in participation for the last IRP, so take that into consideration.

**Ben Otto:** I think providing a public opportunity to comment on the draft IRP before it is finalized is a good idea.

**James Gall (slide 7):** If you want to run scenarios, get a hold of me because you'll need Gurobi and What's Best licenses to make the models work. You can review the results from the model runs without the licenses.

**John Lyons:** We do not have signed contracts yet for the successful bidders of the 2020 Renewables RFP and those contracts will change the near term PRS if signed. For the results of the 2020 renewable RFP, what's the cut-off to include them and rewrite the IRP? Is it the end of January, sometime in February, or some other time?

**Jennifer Snyder:** If possible, at all, it'd be great to have it included, time allowing. If there is only time for a letter or appendices about the contracts, that'd be ok too.

**Ben Otto:** What is the likelihood and scale of changes to the PRS that could come from the RFP?



**James Gall:** It doesn't change the resource need, but it changes the resource mix in the early years.

**John Lyons:** We are hoping to be finished with contracts by end of the first quarter.

### **Review Draft 2021 IRP, John Lyons**

**Jennifer Snyder:** Chapter 13, the EAAG is referred to as the EEAG.

### **Draft Resource Plans and Scenarios, James Gall**

**Mike Morrison:** Could we further discuss the definition of a 5% LOLP?

**James Gall:** Let's defer that to the ARAM discussion.

**Joni Bosh:** What do the green and blue stand for?

**Lori Hermanson:** Green resources are being retired and blue storage resources are being added.

**Thomas Dempsey:** Why is there a 2021 retirement of Colstrip?

**James Gall:** Models show retirement when it's cost-effective, but it doesn't mean Colstrip will retire in 2021.

**Katie Ware:** Did you explore the sensitivity of a mix of lithium-ion and long-duration storage?

**James Gall:** Excellent question. Lithium-ion and long-duration storage are all resource options, so the model when looking at capacity need can choose from any of those resources. Longer duration resources have a higher peak credit which is why it is selected over lithium-ion, even though lithium-ion could be a cheaper resource. Lithium-ion is lowest cost when combined with solar, but liquid air is best for long term storage.

**Katie Ware:** Is there a scenario of storage mixes. *Yes, we'll discuss it in detail later.*

**Yao Yin:** Based on the table and modeling, there are different needs for different resources. How does the company reconcile this when acquiring resources?

**James Gall:** It's a real challenge for us. We identify the need, then need to determine who [which state or system] is driving the need and who is paying for it. We definitely need a company strategy on how to assign responsibility for recovery of new resources and we need to figure out how to do that with the commissions.

**Yao Yin:** How do you decide what resource to acquire in reality when it comes to operational decisions?

**James Gall:** If we acquire all of these, we'll operate them to meet load if needed. Actual acquisitions are decided through a competitive process like an RFP.

**Tina Jayaweera:** Are DR impacts for both summer and winter? *Yes, many impacts for both summer and winter.*

**Yao Yin:** For the DR and energy efficiency programs in the preferred program, are they based on the third-party or the study?

**James Gall:** The third party determines the price and the potential and our model selects the measures.

**Yao Yin:** Are they bundled? *No.* Is DR the same way?

**James Gall:** Yes, each individual measure, about 7,000 of them, can be selected. This is the same by DR and by state.

**Fred Heutte:** I'm wondering about DR, CT2045 for new water heaters and heat pumps, electric resistance, why didn't these show up?

**James Gall:** The costs were given by AEG, it was the next resource in [just missed being selected in this IRP]. The potential was quite large, but it was not competitive. If the pricing comes down about 20% in the next plan, it'll be selected.

**Fred Heutte:** I'm going to investigate AEG's numbers as it doesn't seem this would be that expensive. In my view, utilities in Washington should just acquire these.

**Tina Jayaweera:** Thermostats may not save the same amount in summer as in winter, is the 7 MW in the summer or winter?

**James Gall:** It's the winter savings. I have the summer savings available too, but didn't show them here. They are in the supporting documents. Feel free to dig into them.

**Jennifer Snyder:** Have you done any analysis on bill impacts? The Washington rate is higher but so is energy efficiency, does it make the comparison any different?

**James Gall:** Great question, I don't have the answer. Maybe that's something we can investigate.

**Fred Heutte:** About the below the zero sales, can you walk through the math? My sense is there will always be gas in the market, about half of a coal plant.

**James Gall:** There's several methodologies, you've described one. We sell system power, then incremental cost and emissions change. I try to keep things simple here. For every MW sold, we estimate the amount of emissions the NW emits. It's really an unknown and I try to show it both ways. It goes away in 2025.

**Fred Heutte:** It's a net sales, but if you didn't sell, what's the marginal analysis?

**James Gall:** I agree. I've done it and it's difficult. Average hourly emissions by our system and the regional emissions. However, we can't do that to that level with the models we have. Maybe we can in the future. We have annual models so I don't know how much we bought or sold each hour.

**Fred Heutte:** Agreed, this is a first cut and gives us a sense. It's not easy to do this hourly. Ultimately, we need to land there. Hydro complicates this too.

**Joni Bosh:** So system power is unspecified power?

**James Gall:** Two types of power – Avista's system power, sales and purchases. We don't know what we're buying each hour so we'd have to determine a mix of this.

**Mike Morrison:** Do the liquid air energy storage systems currently in your portfolio assume the existence of waste heat from thermal plants? Is this waste heat generated by hydrogen or biomass? If so, does your modeling include these costs?

**Thomas Dempsey:** 100% renewable is not available yet.

**Mike Morrison:** You assume the use of waste heat to power the high temp side of the engine, but the efficiency was above this.

**Thomas Dempsey:** I believe we provided an answer for that question, but I don't have that in front of me.

**James Gall:** Or we used a lower efficiency in this plan, but I'll need to get back to you on that.

### **2021 IRP Action Items, John Lyons**

**Fred Heutte:** The Power Pool is having an update on resource adequacy next Friday. I'll add a link. [NWPP Resource Adequacy Program public webinar next Friday, Jan. 29, 1-2:30 pacific time <https://www.nwpp.org/events/86> ]

**John Lyons:** Thanks for sharing that around.

**Jennifer Snyder:** I wanted to know if you are looking at other DER investments and how are you planning on doing those in the future?

**James Gall:** We currently evaluate those DER resource options in the plan. The challenge is they're not getting selected from an economic point of view. Are there additional economic or equity benefits that we need to study? Unless there's a specific reason to pick DERs due to a locational benefit to help with the economics, they're not going to be economic and will not be chosen. This takes quite a bit of time to study.

**Jennifer Snyder:** Other values will have to drive it to be accepted.

### **ARAM Model Overview, James Gall**

**Mike Morrison:** What is your definition of LOLP?

**James Gall:** I'll explain it when I open the model.

**Lance Kaufman:** If you're unable to meet your load requirements, it counts as a loss of load event. Can you explain this further?

**James Gall:** We track both ways – if we can't meet our reserve obligations to WECC or we can't meet our load, both can occur at the same time.

**Scott Kinney:** It's a NERC requirement that you have to maintain your operating reserves to avoid blackouts across the whole system. For example, in California this summer during the heat wave, they had to start shedding load. You have to shed load to save the entire interconnection.

**Thomas Dempsey:** Can you clarify the question I thought I heard? Suppose we're carrying 100 MW of reserves, but we need 50 MW. If we have already used it, we no longer have the 100 MW of reserve. Is that situation an event?

**Scott Kinney:** We can call on other reserves in the region.

**Yao Yin:** For existing and/or new resources, how do we determine the capacity?

**James Gall:** For both existing and new resources, and we will get to the capacity later in the presentation.

**Lance Kaufman:** Can you explain the dispatch logic? Are things being co-optimized? How is thermal, hydro/storage being re-dispatched?

**James Gall:** The model is not concerned with cost but with availability. It will dispatch based on a priority of economics. Each resource is trying to serve that load equally but in a high load event everything will run.

**Lance Kaufman:** Will you cover storage logic later?

**James Gall:** Yes. This is a reliability model. The first version was with no economics. This model now has economics included.

**Mike Louis:** If the market is used to meet reserves, is the amount constrained?

**James Gall:** Essentially, from a market point of view, we're using our reserves to meet the load. We could buy from the market in the future to meet reserves.

**Lance Kaufman:** Is there a risk of having that flat so that it misrepresents reliability?

**James Gall:** I haven't tested that. There could be a couple of months where there could be a reliability problem. I'm leaning toward it not being a big impact, but I don't know for sure without testing.

**Andreas Alvarez:** What timeframe is the model optimizing these storage resources?

**James Gall:** All 8760 at the same time. The model has perfect foresight, which is more than reality.

**Yao Yin:** Where is the 16% planning margin located?

**James Gall:** It's not an actual input or output. We're going to talk about this more later.

**Andreas Alvarez:** When it's storing, is it seeing a price for charging?

**James Gall:** Yes, there's an economic charge for charging and dispatching storage. It is set up with a very high price to not serve load, so it is optimizing to serve load. Really only focusing on hours where there will be an hour needed.

**Andreas Alvarez:** It's charged for that hour to avoid the \$5,000.

**Mike Morrison:** How are storage efficiencies determined?

**James Gall:** Determined by what storage resource was chosen.

**Mike Morrison:** How does it keep track of when storage devices are charging and dispatching?

**James Gall:** Showed the dispatching versus charging in the model. It can't draw more than what the limits are.

**Mike Morrison:** Is the model smart enough to say the battery isn't charged enough or what needs to be charged?

**James Gall:** The power of the What's Best program is that it creates a linear equation to solve for the parameters, subject to constraints, to minimize the cost to serve load.

**Lance Kaufman:** Could you clarify for the hourly load forecast, when you say you're looking at historical years, are you taking historic temperatures and putting them into the current forecast?

**James Gall:** Yes. Load forecast with weather using actual data for a particular year. In theory. We have to create a regression to create an hourly load shape and match that with weather.

**Lance Kaufman:** Where would we look to see the details of this by year?

**James Gall:** Historical hourly loads are used to create a regression equation which is used to multiply the historical daily temperatures to estimate the hourly loads included in the model. Since the ARAM model includes proprietary data it can't be shared.

**Lance Kaufman:** On the years tab, have you done analysis between the water year and the load year?

**James Gall:** Yes, on an annual basis. On an annual basis there is no correlation, but on a weekly basis, there could be correlation. We're varying these inputs on an annual basis. We chose not to put a correlation in there.

**Andreas Alvarez:** Is Montana wind assumed to be central or eastern?

**James Gall:** It is eastern Montana wind. I don't recall which wind turbine was used.

**James Gall:** Yao asked earlier how this relates to planning margin. We are trying to get as close to 5% LOLP as possible. So the question is how many resources or how much market availability do I have to add to achieve this? Here we will put a constraint on how much can come from the market. We're concerned with really hot or cold days – those are the days we're concerned about market availability. If the temperature is above 80 or below 2 degrees, it triggers a market availability constraint. The 16% planning margin is the amount of extra resources needed above our load assuming this constrained market availability.

**Andreas Alvarez:** Will you be going over peak capacity contributions?

**James Gall:** If I reduced gas and increased wind to come up with the same LOLP that would result in a 25% peak credit. The difficulty is when you add more wind the value of the peak credit degrades.

### **Clean Energy Implementation Plan and Clean Energy Action Plan, James Gall**

**Yao Yin:** Is there a separate preferred portfolio for each state?

**James Gall:** Our PRS identifies what resources are driven by each state, but all resources are needed.

**Yao Yin:** In the ARAM model, do we look at the entire system? Yes.

**Jennifer Snyder:** Is John the main contact? Are you considering the CEIP being the same team makeup as the IRP?

**James Gall:** We have not decided yet. We'll be working on that.

### **Draft IRP Comments from TAC**

**Mike Morrison:** I've perused the draft. You definitely listened to some of our last comments and incorporated them. I appreciate that. I'll be really looking at the capacity calculations and making sure the assumptions make sense. Anything you can do to

enlighten me would be helpful. Keep up the good work. This has been a really helpful presentation.

**James Gall:** John is taking notes and we'll be putting these on our website. We'll respond where we can today if possible and for sure later in the final IRP.

**Yao Yin:** A clarifying question, for the preferred portfolio on the list of system need and by Idaho and Washington, did you mean that the final list includes all resources and this slide identifies the drivers?

**James Gall:** Correct. The slide includes all preferred resources needed to serve the system and the color of each resource identifies the driver as being system, Idaho or Washington.

**Jennifer Snyder:** The UTC doesn't necessarily expect you to meet everything in this IRP since the rules just came out. Can you add in some narrative on the maximum customer benefit scenario and what that might look like to help with the discussion going forward?

**James Gall:** I don't know if the drafters of the rule have an expectation of what they're expecting for that scenario. The definition of the maximum customer benefit scenario is what I am challenged by. I'm puzzled on what it means.

**Jennifer Snyder:** You and I are right there on that. PSE is doing 150% of cost-effectiveness for energy efficiency. I don't necessarily think this is the way to go. If you were going to increase the customer benefit, how would you maximize things?

**James Gall:** What is the meaning of customer benefit – reliability, financial, etc.? We're already solving for the maximum financial benefit. We'll mull it over. I think we already have the scenario like PSE.

**Shawn Bonfield:** The newly formed equity advisory group may inform this scenario from that perspective. I see this as a narrative of how we'll use that group.

**Yao Yin:** On the slide about all the chapter content, for chapter 13 on the use of the preferred portfolio in determining avoided costs, did you mean for PURPA or for energy efficiency?

**James Gall:** We meant for both. Avoided cost of our preferred strategy which could be used for PURPA, energy efficiency or a supply-side resource. We will be adding the estimated avoided costs showing how folks can calculate the avoided costs of their particular resource.

**Yao Yin:** What is your justification of using the preferred portfolio of new resources instead of existing resources?

**James Gall:** We have an existing resource stack, but if we had a new resource to consider the cost we are avoiding would be from acquiring a new resource.



# 2021 Integrated Resource Planning

February 24, 2021



## Meeting Format

- 5:00 to 6:00
  - Welcome- Jason Thackston, SVP of Energy Resources
  - Overview of Avista's Electric Resource Plan- James Gall
  - Overview of Avista's Natural Gas Resource Plan- Tom Pardee
- 6:00 to 6:30
  - Attend first breakout session
- 6:30 to 7:00
  - Attend second breakout session
- This meeting will be recorded

## Objectives of Today's Meeting

- Overview of Avista's electric and natural gas systems.
- Learn about considerations when planning to meet customer load.
- Explore Avista's proposed resource plan for natural gas and electric supply.
- Opportunity to ask questions and provide feedback in breakout sessions.
- Poll questions to provide instant feedback.

# Avista Generation Capability of Company- Owned Resources and Service Territory



Exh. JRT-2a  
**Washington** CUSTOMERS

Electric 243,031  
Natural Gas 153,467

**Idaho** CUSTOMERS

Electric 127,134  
Natural Gas 78,061

**Oregon** CUSTOMERS

Natural Gas 98,194

**Non utility-owned or operated** GENERATION CAPABILITY (MW)

- 16 Lancaster N.G. (fired) (Rathdrum, ID) .....270.0
- 17 Palouse Wind (Oakesdale, WA)..... 105.0

**Hydroelectric** GENERATION CAPABILITY (MW)

1	Noxon Rapids (Noxon, MT)	562.4
2	Cabinet Gorge (Clark Fork, ID)	273.0
3	Long Lake (Spokane, WA)	88.0
4	Little Falls (Spokane, WA)	35.6
5	Nine Mile (Spokane, WA)	22.4
6	Post Falls (Post Falls, ID)	15.4
7	Monroe Street (Spokane, WA)	15.0
8	Upper Falls (Spokane, WA)	10.2
<b>Total Hydroelectric Capability</b>		<b>1,022.0</b>

**Thermal** GENERATION CAPABILITY (MW)

9	Coyote Springs (Boardman, OR)	284.4
10	Colstrip (Units 3&4) (Colstrip, MT)	222.0
11	Rathdrum Combustion Turbines (Rathdrum, ID)	166.5
12	Northeast Combustion Turbines (Spokane, WA)	64.8
13	Kettle Falls Biomass Plant (Kettle Falls, WA)	53.5
14	Boulder Park (Spokane, WA)	24.0
15	Kettle Falls Combustion Turbine (Kettle Falls, WA)	6.9
<b>Total Thermal Capability</b>		<b>822.1</b>

Avista also owns Alaska  
Light & Power in  
Juneau, AK

# Maintaining Balance is Important

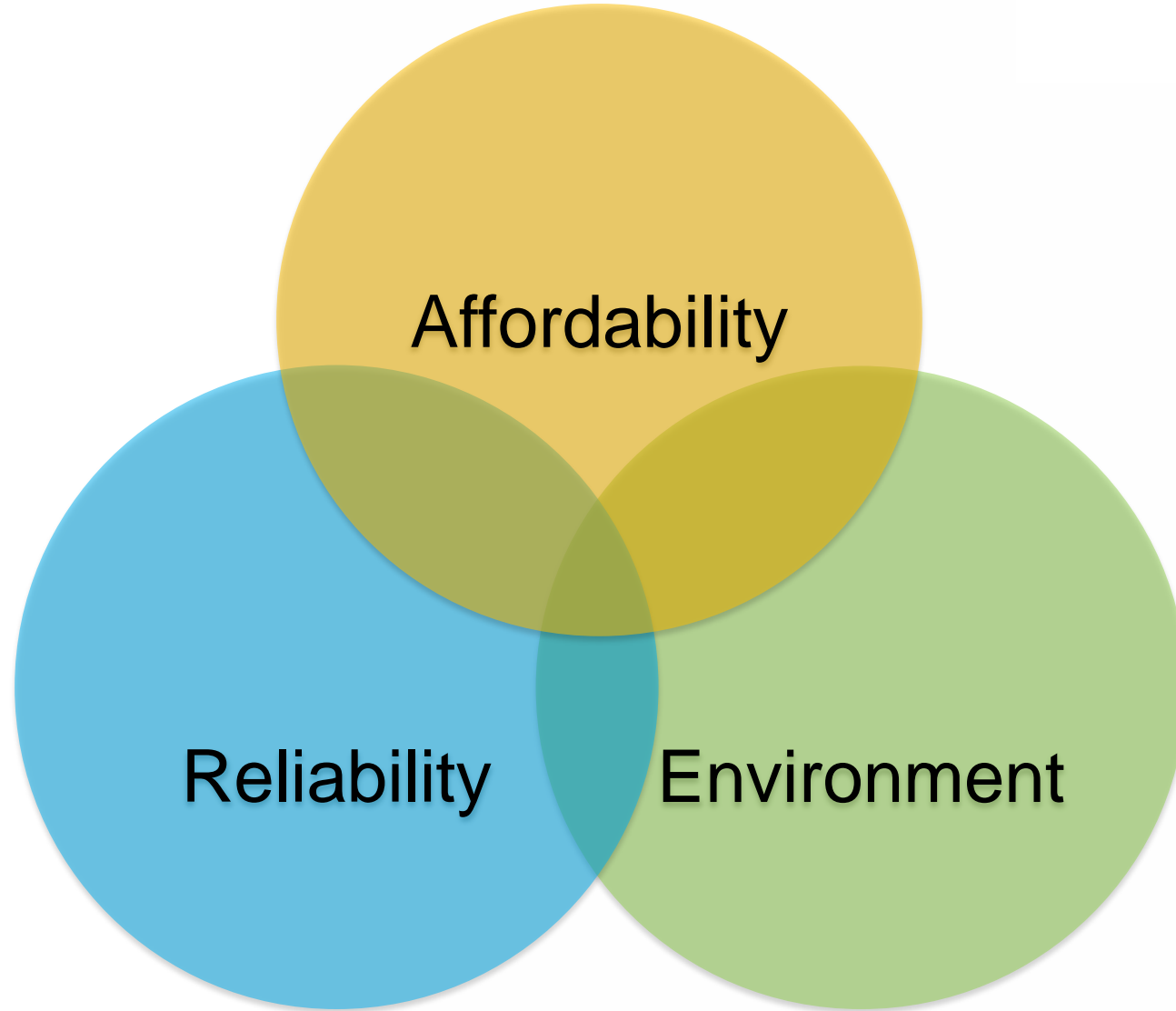

## Avista's Clean Electricity Goal

Avista's goal is to serve our customers with **100 percent clean electricity by 2045** and to have a **carbon-neutral** supply of electricity by the end of **2027**

- We will maintain focus on **reliability** and **affordability**
- **Natural gas** is an important part of a clean energy future
- **Technologies and associated costs** need to emerge and mature in order for us to achieve our stated goals
- It's **not** just about generation



## Providing Cleaner Natural Gas

- We are committed to reducing **greenhouse gas emissions** in our natural gas business too
- Achieving reductions requires an “**all-of-the-above**” approach:
  - **Gas supply and distribution opportunities** like renewable natural gas
  - **Upstream strategies** like targeted sourcing with suppliers
  - **Engagement with customers** to increase energy efficiency, demand response, and voluntary programs
- Just like our clean electricity goals, reducing greenhouse gas emissions in our natural gas system will require **advances in technology** and **reductions in the cost** of those technologies
- **Affordability** will guide our decisions



## What is the Purpose of an IRP?

- Required to be filed with our state regulating commissions every two years.
- Allows for public feedback and participation.
- Commissions acknowledge plans but do not approve the plans.
- Understand supply needs to serve our customers over the next 20 years.
- Evaluate resource options to meet future needs.
- Determine which resources are best suited to meet customer need.
- Sets course for acquisition of resources.



# Electric Integrated Resource Plan

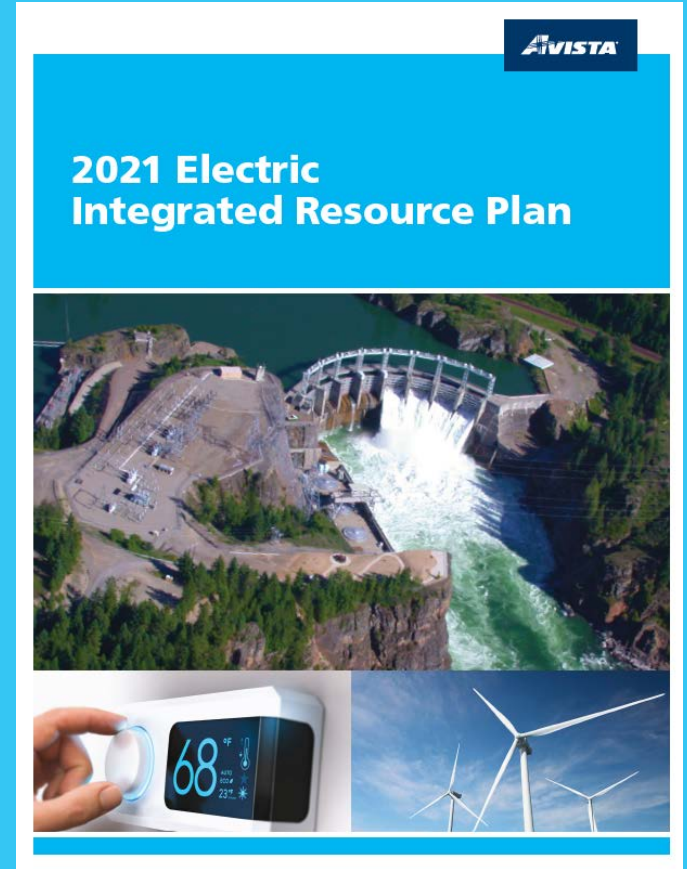



# What makes up your energy rate?

## Begins with Cost to Serve All Customers

Electric

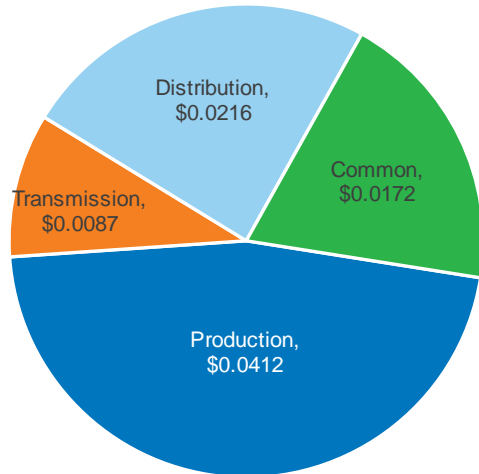

Natural Gas

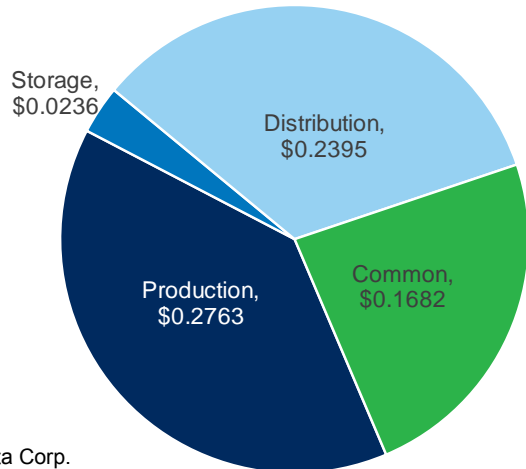

## Customer Type

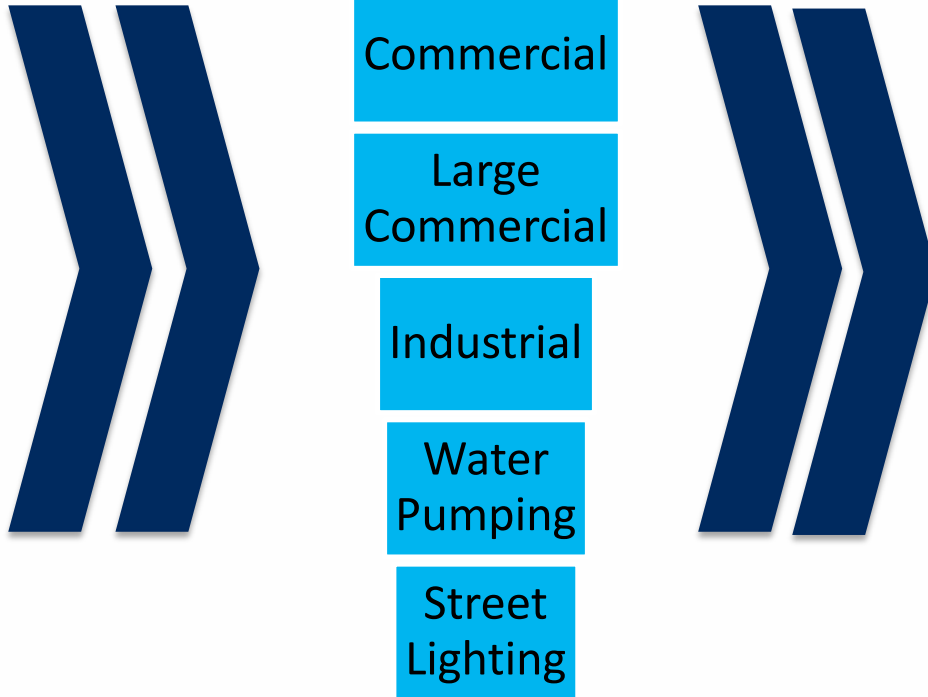

## Pricing Type

**Fixed Charge**  
Monthly connection charge

**Energy Charge**  
The amount of energy used over the month

**Demand Charge**  
The highest use over an hour in the last 12 months

# What fuels our generating resources?

## Winter Peak Capability

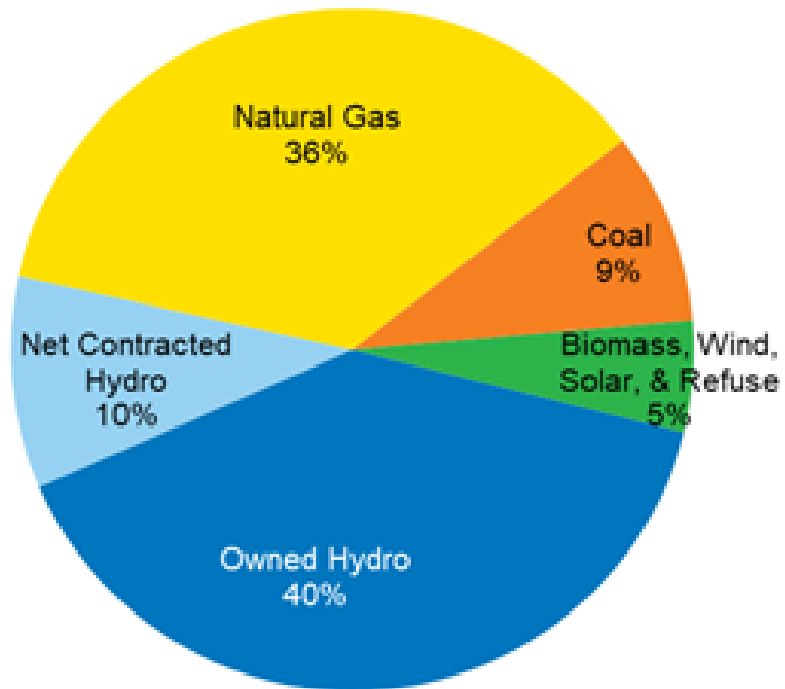

## Annual Energy Capability

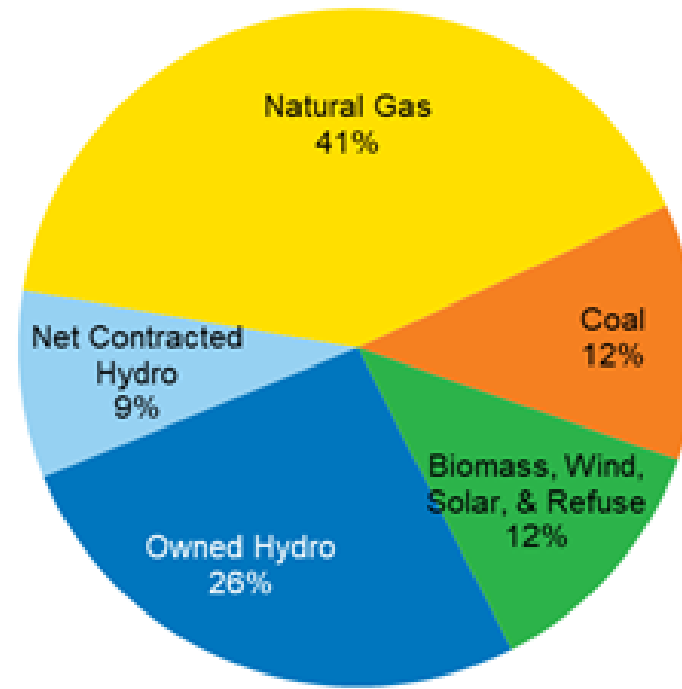

# Why does Avista need new electric resources?

## Meet System Winter Peak Load

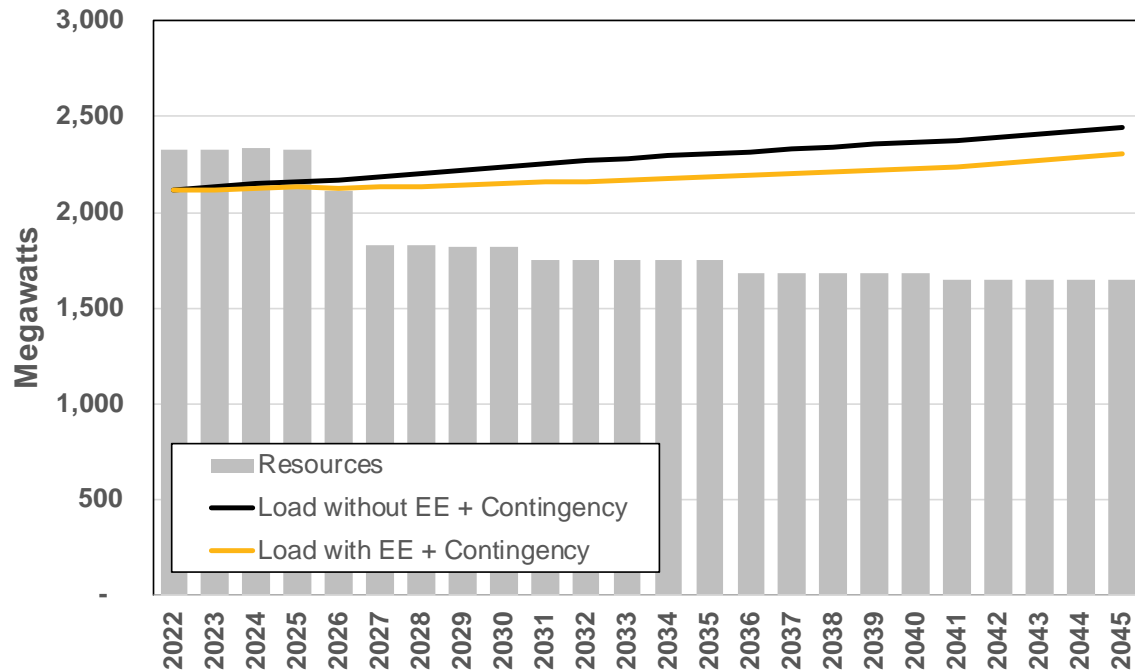

## Meet Washington Clean Energy Requirements

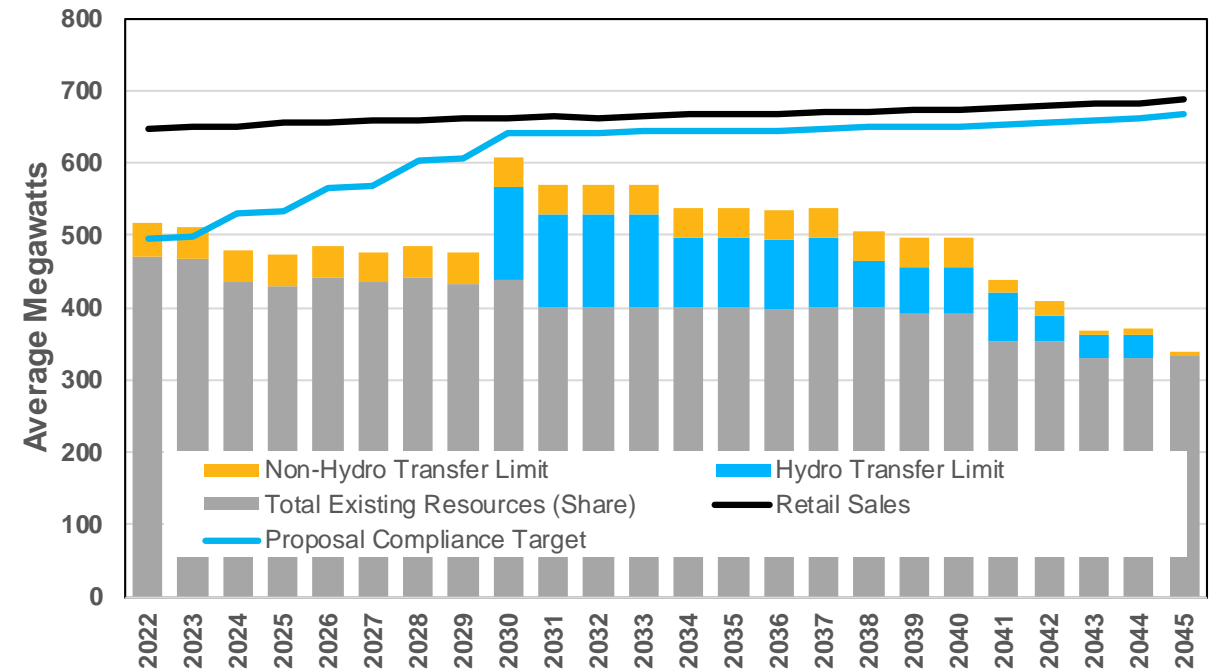

Avista also plan to meet summer peak conditions & to ensure it generates enough energy over the course of the year in poor hydro conditions.

2021 Electric IR Appendix

# What are the available options to meet our electric customer obligations?

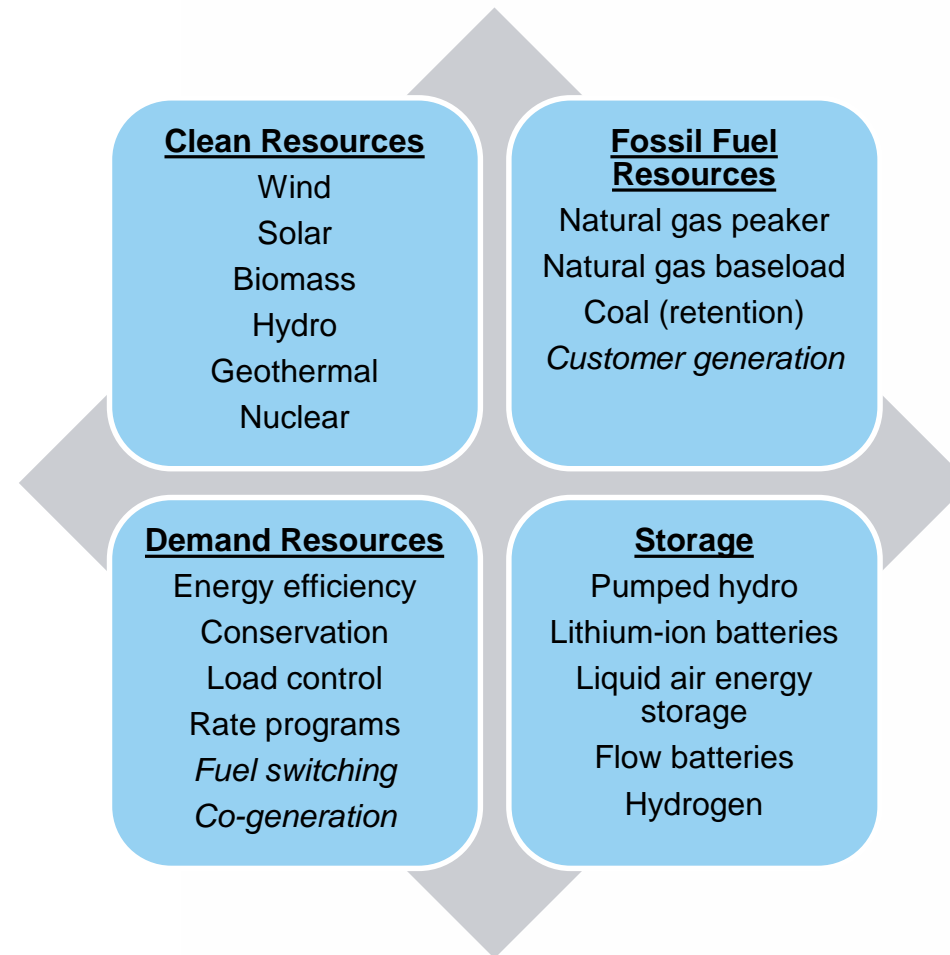

# Electric IRP's Preferred Resource Strategy over the next 10 years

## Generation Portfolio

- By end of 2025: Exit Colstrip
- 2023-24: Add new renewables (i.e. wind, solar, hydro)
- 2026-2027: Replace Lancaster natural gas plant (natural gas generation is lowest cost option) & increase capacity at the Kettle Falls Generating Station & Post Falls
- 2028: Add new renewable resources (Montana wind)
- 2031: Acquire existing Northwest Hydro Capacity
- 2035: Replace Northeast natural gas plant with upgrades to Rathdrum CT and acquire new capacity

## Energy Efficiency

- Energy Efficiency meets 68% of future load growth
- Industrial & commercial customers provide 2/3 of savings
- Residential Single family home is largest single segment
- Washington top targets: Lighting, space heating, water heating, refrigeration, and cooling
- Idaho to targets: Lighting, space heating, and motors

## Demand Response

- 2024: Offer new rate programs (opt-in)  
(Time of use rates & variable peak pricing)
- 2026/27: Industrial load control
- 2031-32: Smart thermostat controls and commercial load control



# Avista's Cleaner Future

- Clean energy percent of system sales increase to 78% by 2027 and 86% by 2045.

## Clean Energy Forecast

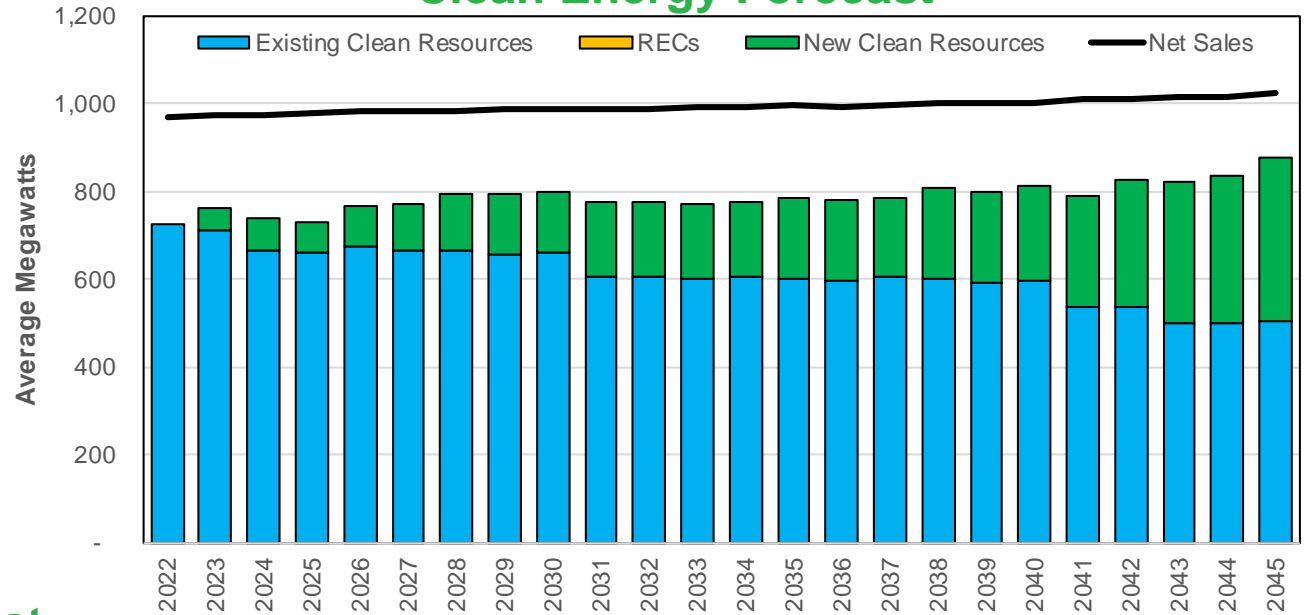

## Greenhouse Gas Emission Forecast

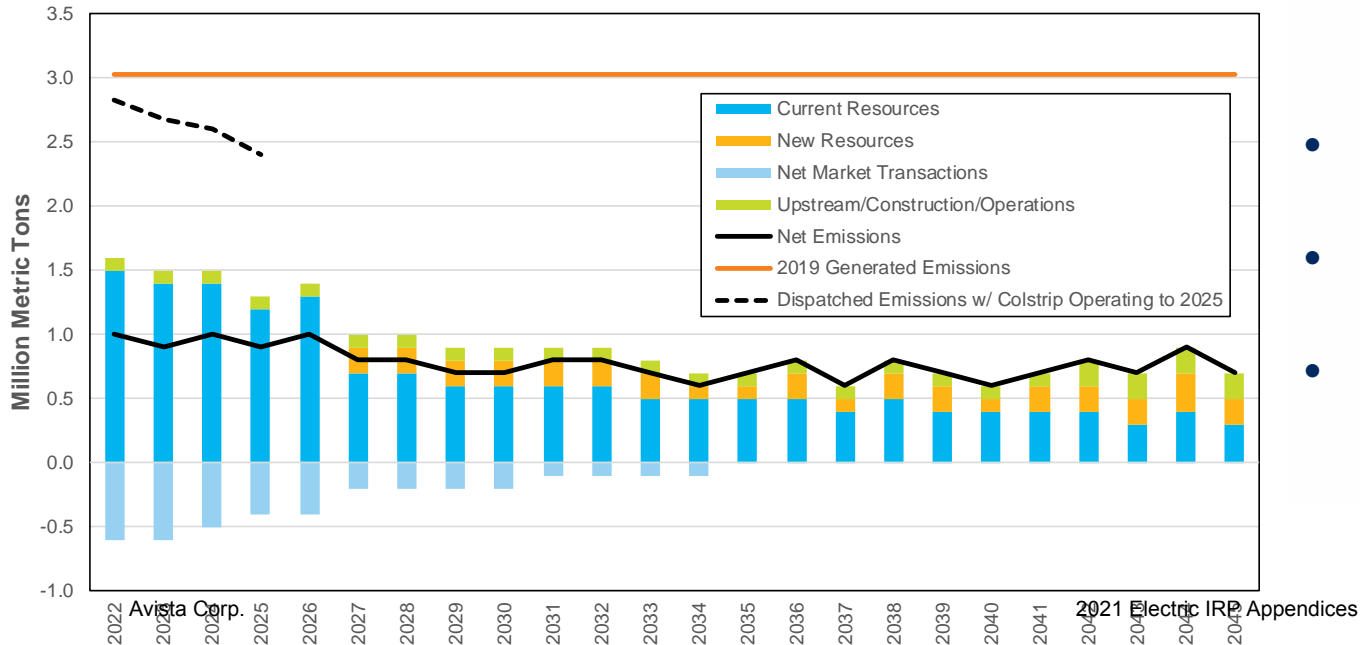

- By 2030, Avista's greenhouse gas emissions fall by 76 percent.
- 2019 Northwest power emissions were 57 million metric tons (Avista is 5.2% of those emissions).
- Power is 20% of all NW greenhouse gas emissions.





# Natural Gas Integrated Resource Plan



# Existing Resources vs. Peak Day Demand

## Idaho and Washington

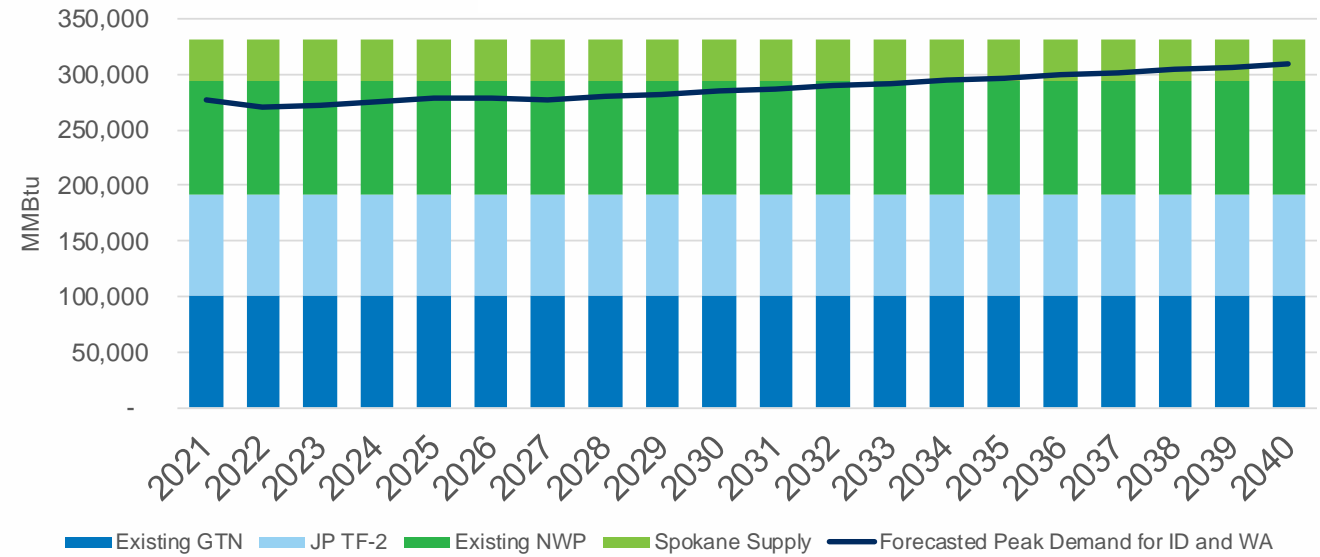

## Medford and Roseburg

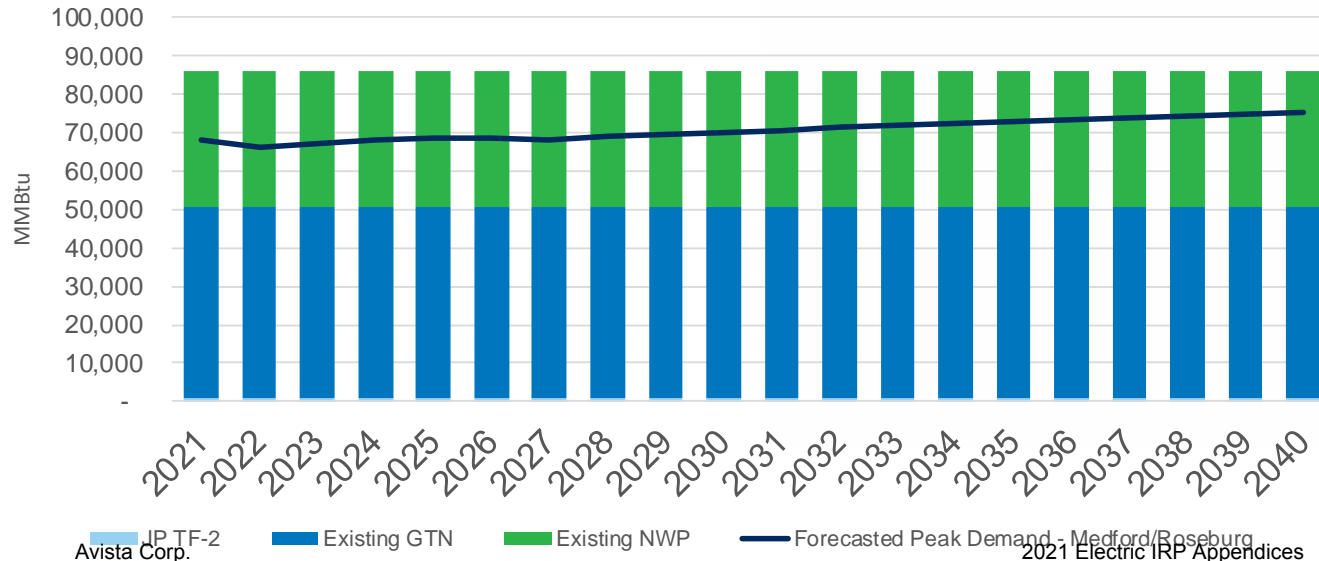



## What are the available options to meet our natural gas customer obligations?

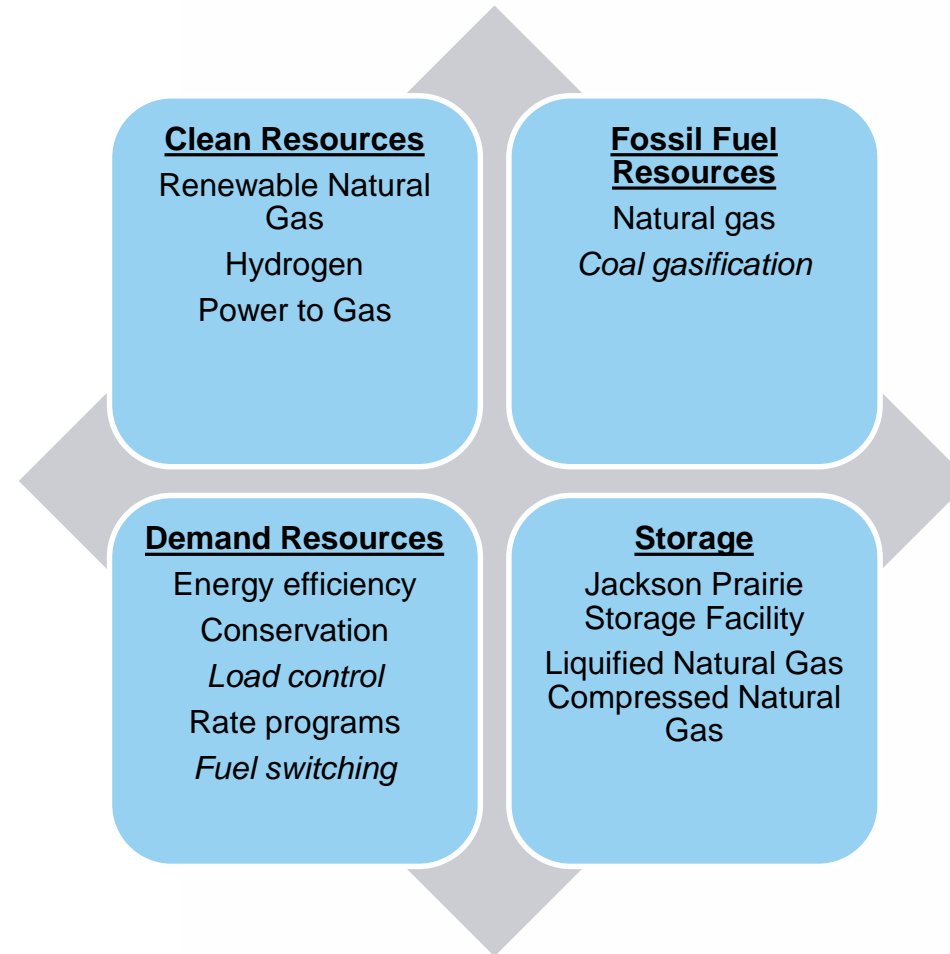

# Natural Gas System Cost vs Carbon Adder

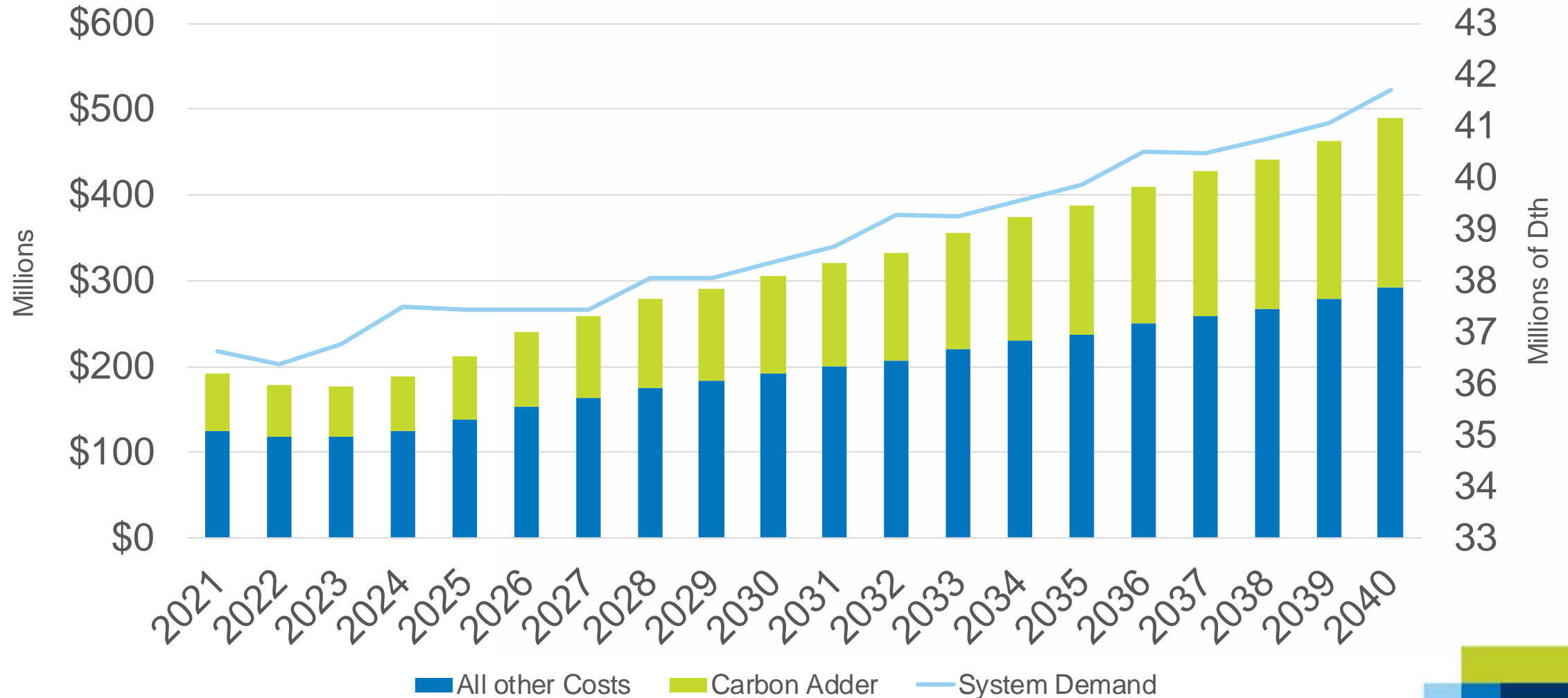

■ All other Costs   ■ Carbon Adder   — System Demand

# Avista Natural Gas – A Cleaner Future

## Carbon Reduction Goals (Oregon & Washington)

### 2019 Retail Energy Delivered

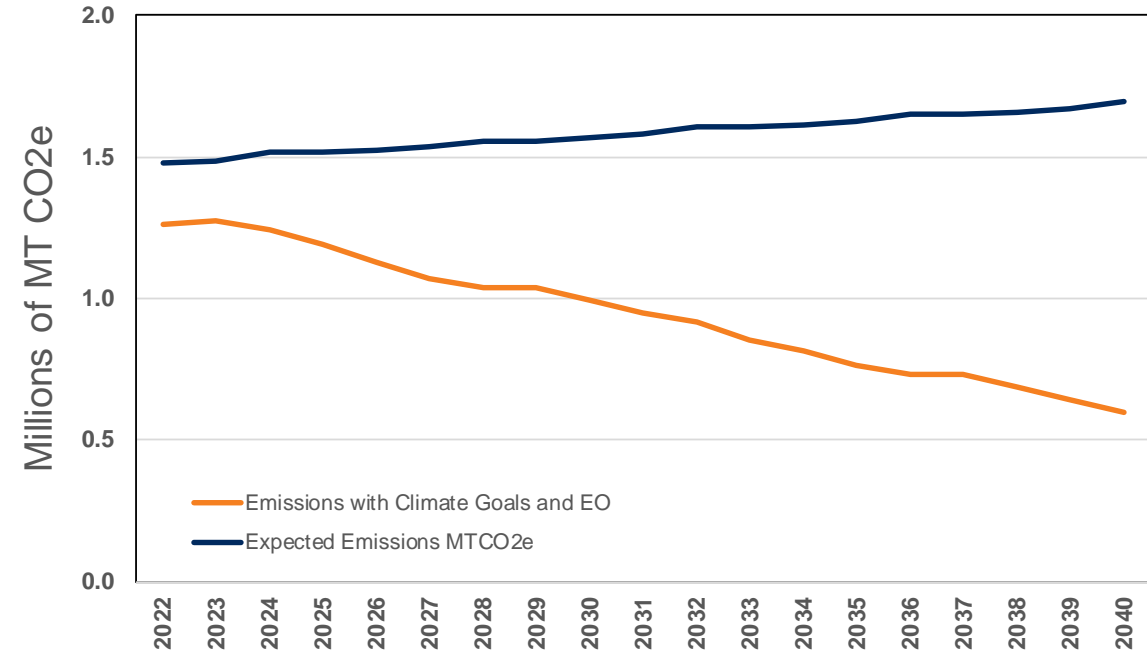
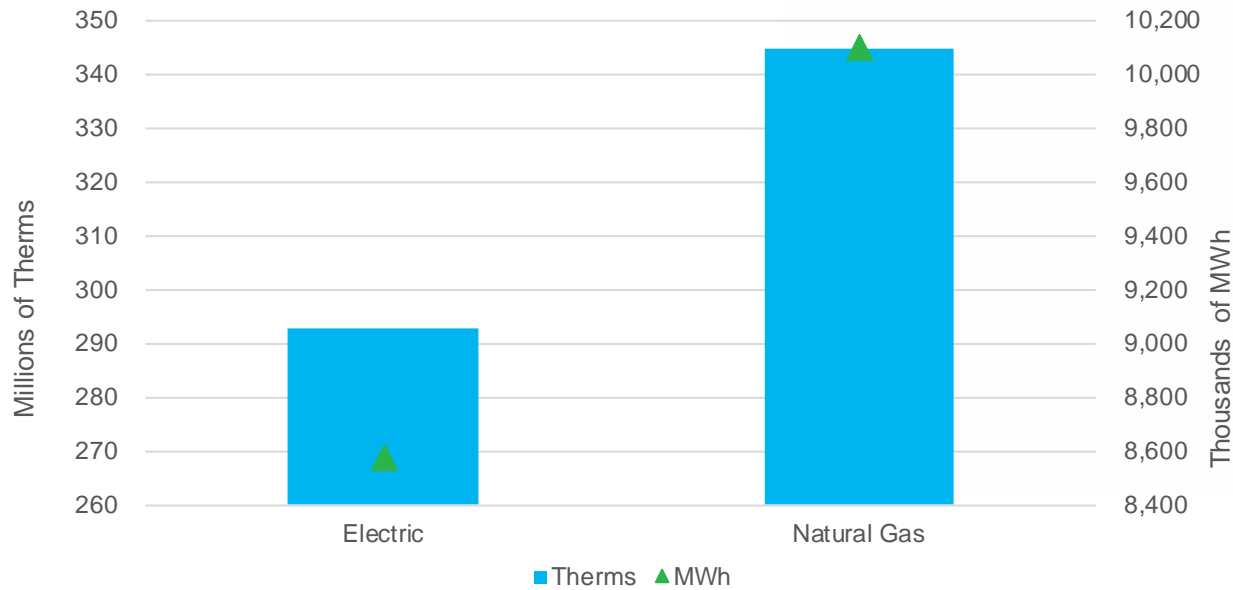

### Oregon - Executive Order 20-04

- 80% reduction by 2050

### Washington - Goal

- 95% reduction by 2050

## How do I get involved with the IRP?

How to learn more:

<https://myavista.com/about-us/integrated-resource-planning>

Email: [irp@avistacorp.com](mailto:irp@avistacorp.com)

### Washington UTC

[www.utc.wa.gov](http://www.utc.wa.gov)

Electric Docket: UE-200301

Natural Gas Docket: UG-190724

### Idaho PUC

<https://puc.idaho.gov/>

### Oregon PUC

[www.oregon.gov/puc](http://www.oregon.gov/puc)

- Breakout rooms today
- Provide written comments to Avista's planning team by March 5<sup>th</sup>.
- Provide written comments to your state's commission
- Join Avista's Technical Advisory Committees
  - Electric IRP
  - Natural Gas IRP
  - Energy Efficiency
- Future participation opportunities
  - Equity
  - Energy Assistance
  - Distribution Planning

## Breakout Sessions

- Two 30 minute break out room opportunities.
- You can access breakout rooms by using the links in the chat box or stay in this session
  - **Passcode: Avista**
- Short presentation by Avista staff (5 minutes)
- Opportunity to ask Avista staff questions or provide comments.
- Any questions not answered today will be available on the IRP Avista website by March 12.
- Limit of 300 participants in each room

### • Generation Resource Selection & Reliability

- Stay here or use registration link
- Webinar ID: 82608251 3174

### • Energy Efficiency & Demand Response

- <https://us02web.zoom.us/j/82664724856?pwd=QzdUMk9zUE1nRjViYTIXRkJ5S2p5UT09>
- Meeting ID: 826 6472 4856

### • Affordability & Equity

- <https://us02web.zoom.us/j/88435288369?pwd=bGtNK3JYbTBCcktCV2JMRE1sT09CZz09>
- Meeting ID: 884 3528 8369

### • Environmental Topics

- <https://us02web.zoom.us/j/89096065417?pwd=M0FzYWZhdjhTQlRRR2xwOSs4M1ByZz09>
- Meeting ID: 890 9606 5417

### • Natural Gas Service

- <https://us02web.zoom.us/j/84369554229?pwd=YkZJc0ZrUm91NVFSanNjNmXPaVB4UT09>
- Meeting ID: 843 6955 4229

## Breakout Session Ground Rules

- Due to the large response to this public meeting, please limit oral comments and questions to 30 seconds.
  - Avista will try to answer all questions.
  - Avista will also provide written responses if we cannot fully address the question.
  - Comments will be acknowledged and recorded.
- If you would like to make a comment or ask a question.
  - Use the “raise hand” feature in the meeting controls.
  - We will call upon each person to speak.
  - Please comment on areas within the breakout topic
- Please do not repeat questions or comments.
  - If you have the same comments- please indicate in the chat box or send an email to [irp@avistacorp.com](mailto:irp@avistacorp.com) with your comment
- In the event we do not get to your comment or question in the allotted time, please email [irp@avistacorp.com](mailto:irp@avistacorp.com)
- Please limit comments or questions to resource planning- this means in relation to the energy we serve and not the delivery of energy. If you have these questions or any others please see.
  - <http://myavista.com/smartmeters>
  - [askavista@myavista.com](mailto:askavista@myavista.com)



# Resource Selection & Reliability Breakout Room

James Gall  
Thomas Dempsey  
Damon Fisher

# Resource Options

- Multiple factors drive resource selection
  - Cost or price
  - Clean vs. fossil fuel
  - Capacity value or “peak credit”
  - Storage vs. energy production
  - Location
  - Availability (new vs. existing)
- Resource retirements
  - Future capital investment
  - Operating & maintenance cost/availability
  - Fuel availability
  - Carbon pricing risk
- Non-energy costs & benefits
  - Social cost of carbon
  - Locational siting
  - Health, economic, and other benefits (still to come)

Avista Corp.

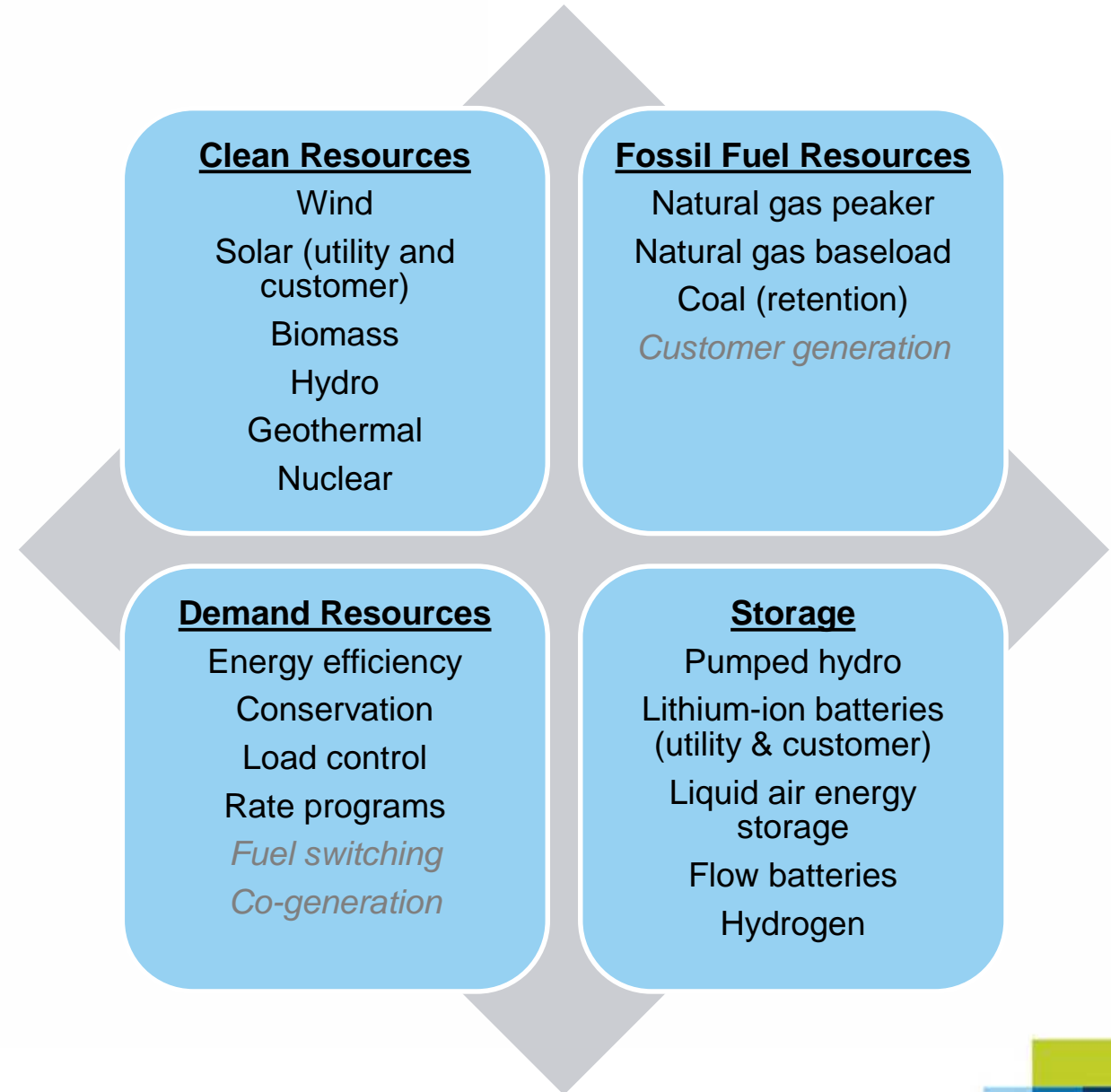



## Supply-Side Resource Changes

- Long-term acquisition of new resources will be conducted with a public request for proposals (RFP).
  - Avista recently added the Rattlesnake Flat Wind project in 2020.
  - Avista is currently working with clean energy proposals from its most recent RFP- this RFP will determine a portion of the resource need in 2023-2024.
- New resource selection is determined by deliverability and lowest economic cost subject to resource policy requirements of each state

Resource Type	Year	State	Capability (MW)
Colstrip (Coal)	By end of 2025	System	(222)
Montana wind	2023	WA	100
Montana wind	2024	WA	100
Lancaster (Natural Gas)	2026	System	(257)
Post Falls Modernization (Hydro)	2026	System	8
Kettle Falls upgrade (Wood-Biomass)	2026	System	12
Natural gas peaker	2027	ID	85
Natural gas peaker	2027	System	126
Montana wind	2028	WA	100
NW Hydro Slice	2031	WA	75
Rathdrum CT upgrade (Natural Gas)	2035	System	5
Northeast (Natural Gas)	2035	System	(54)
Natural gas peaker	2036	System	87
Solar w/ storage	2038	System	100
4-hr storage for solar	2038	System	50
Boulder Park (Natural Gas)	2040	System	(25)
Natural gas peaker	2041	ID	36
Montana wind	2041	WA	100
Solar w/ storage	2042-2043	WA	239
4-hr storage for solar	2042-2043	WA	119
Liquid air energy storage	2044	WA	12
Liquid air energy storage	2045	ID	10
Solar w/ storage	2045	WA	149
4-hr storage for solar	2045	WA	75
Supply-side resource net total (MW)			1,032
Supply-side resource total additions (MW)			1,589



# Energy Efficiency and Demand Response Breakout Room

Ryan Finesilver  
Leona Haley

# Energy Efficiency & Demand Response

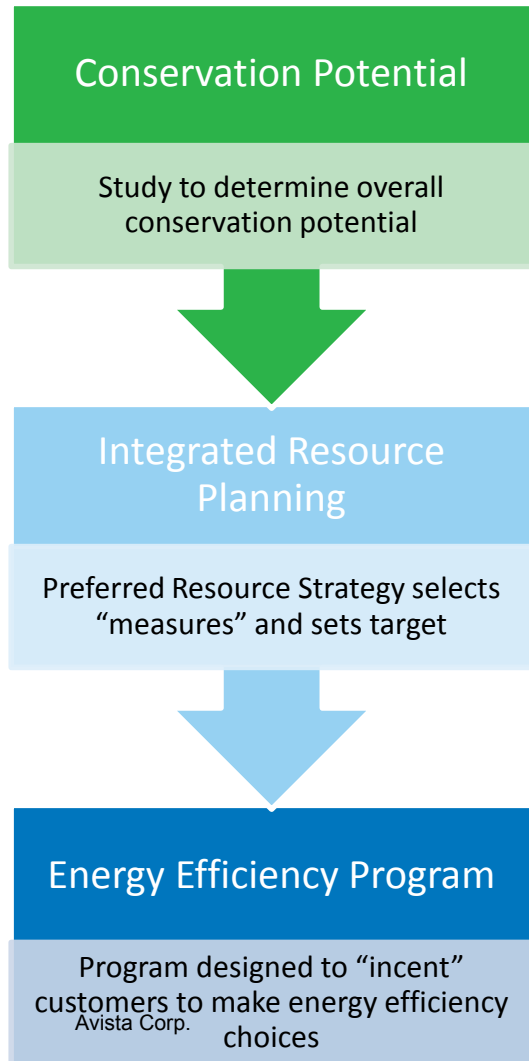

## 10-YEAR GWH CONSERVATION POTENTIAL

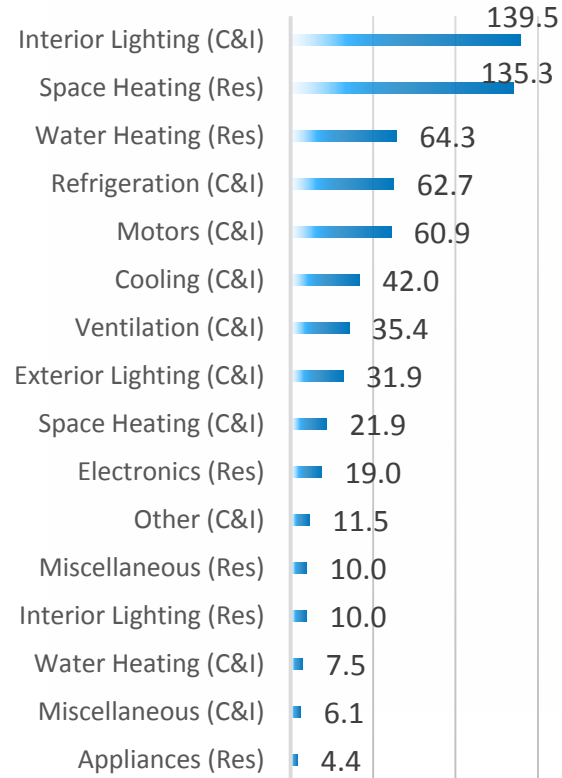

2021 Electric IRP Appendices

## Demand Response

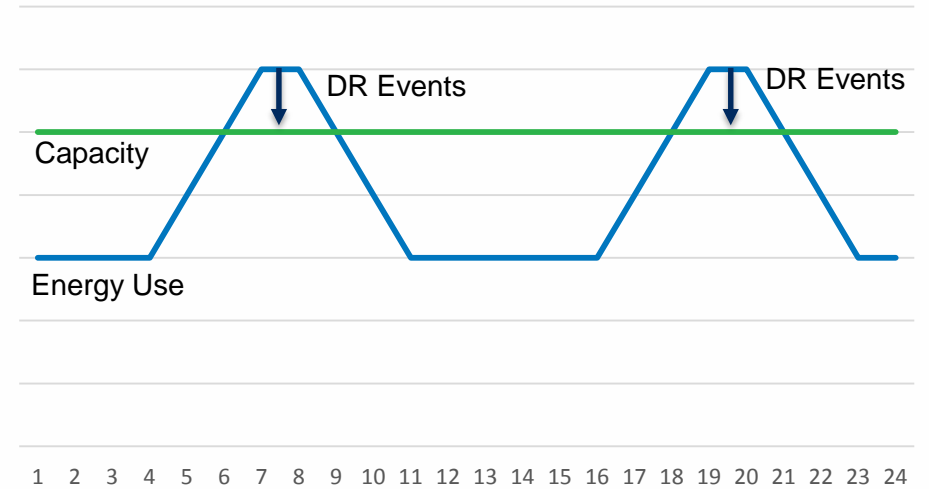

Program	Washington	Idaho
Time of Use Rates	2 MW (2024)	2 MW (2024)
Variable Peak Pricing	7 MW (2024)	6 MW (2024)
Large C&I Program	25 MW (2027)	n/a
DLC Smart Thermostats	7 MW (2031)	n/a
Third Party Contracts	14 MW (2032)	8 MW (2024)
Behavioral	1 MW (2041)	n/a
<b>Total</b>	<b>56 MW</b>	<b>15 MW</b>

# Natural Gas Energy Efficiency

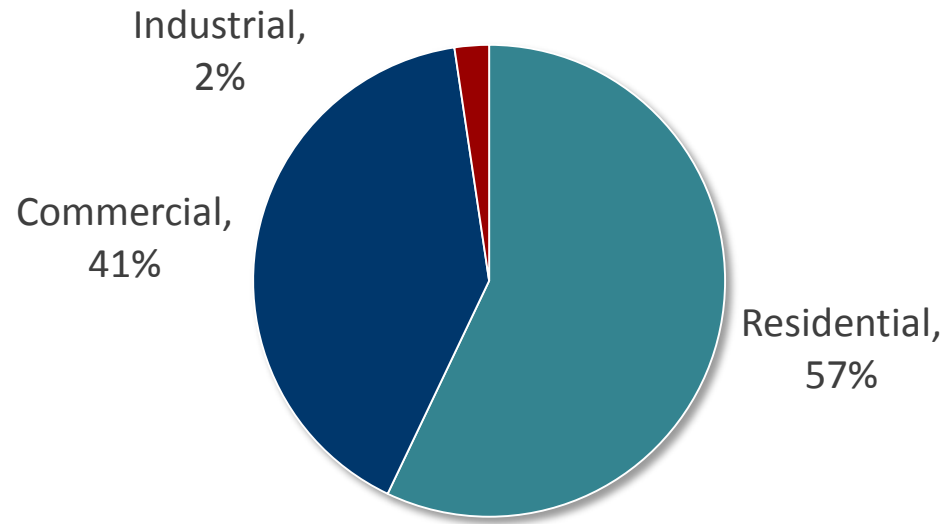

## Millions of Therms

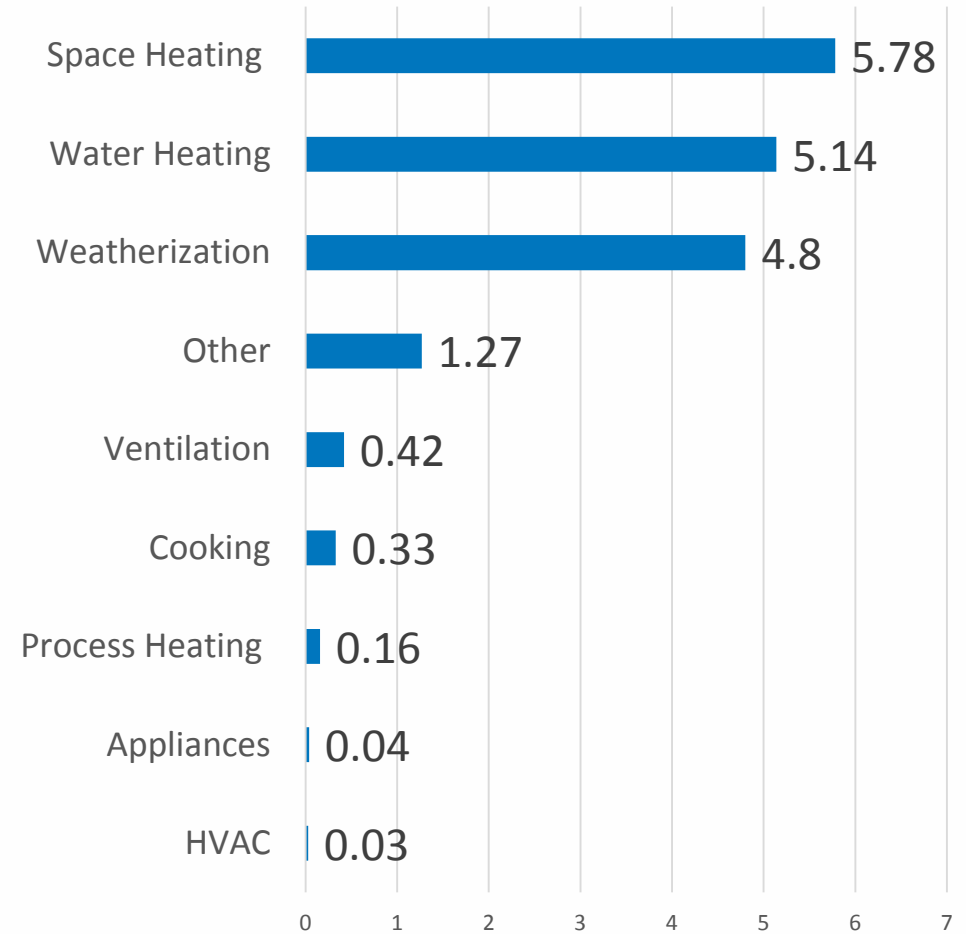

## Way to Save

<https://www.myavista.com/energy-savings/way-to-save>

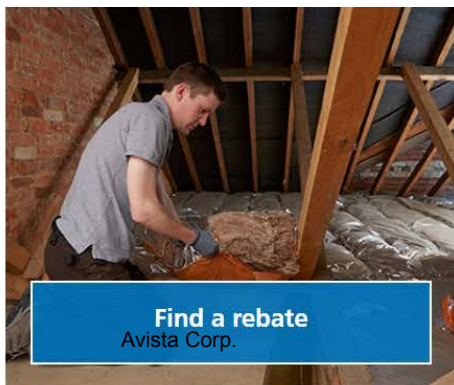



# Affordability and Equity Breakout Room

Ana Matthews  
Shawn Bonfield  
Renee Coelho  
Lisa McGarity

# Energy Rate Forecasts

## Electric Rates:

- To meet Avista’s reliability requirements and Washington clean energy policies electric rates will increase.
- Today, Washington rates are ~1 cent (12%) higher per “average” kWh.
- Going forward the difference between Washington and Idaho rates will continue to separate.
  - Both Idaho and Washington customers financially benefit by lower rates unless Idaho’s share of clean resources are kept in Idaho.

## Natural Gas Rates:

- Natural gas rate increases are driven by increases in the price to acquire the natural gas commodity and general inflation to operate the system.

## Electric Power Cost Rate Changes

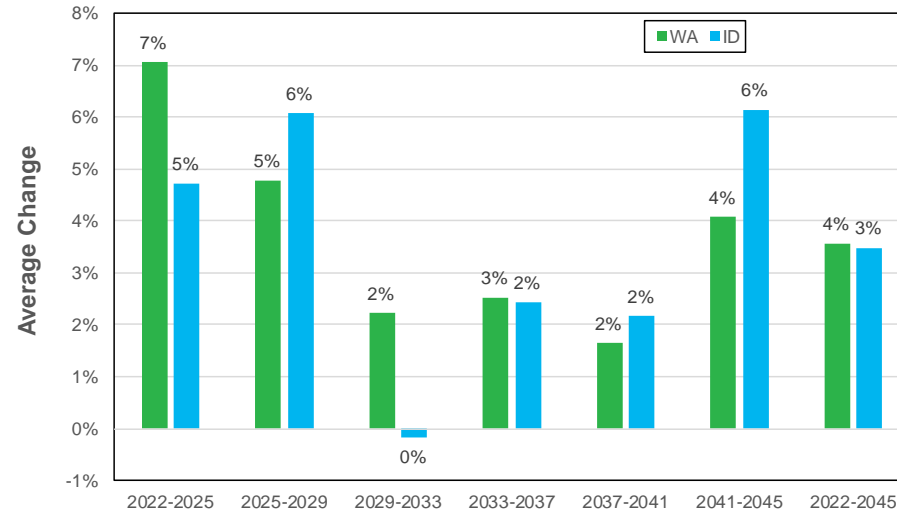

## Annual Average Natural Gas Rate Forecast

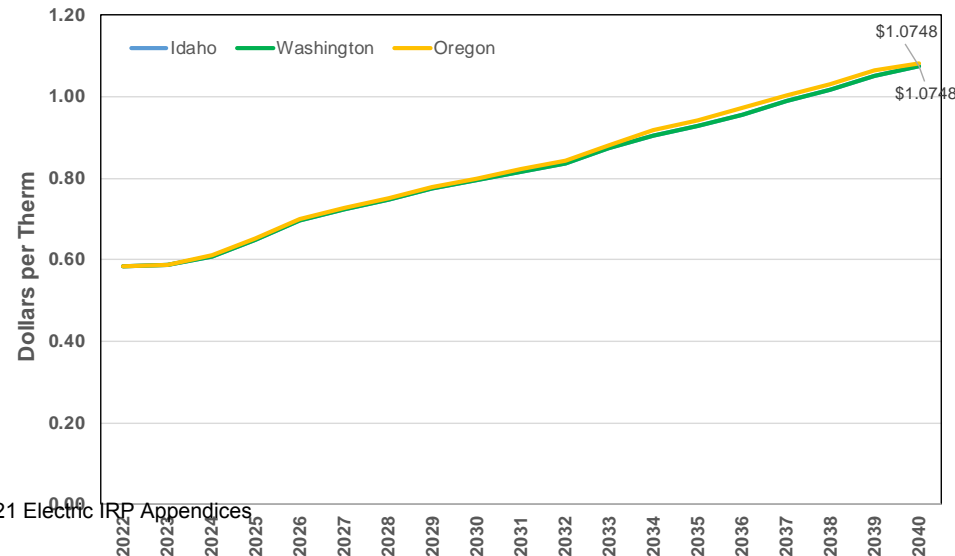

Note: Assumes 2% annual increase in non-energy resource costs

## Energy Equity and Energy Assistance Overview

- Washington State's recently passed legislation CETA (Clean Energy Transformation Act) requires
  - equitable distribution of energy benefits and reduction of burdens to vulnerable populations and highly impacted communities;
  - long-term and short-term public health, economic, and environmental benefits and the reduction of costs and risks;
  - and energy security and resiliency.
- It is the intent of the legislature that in achieving this policy for Washington, there should not be an increase in environmental health impacts to highly impacted communities.

### Bill Assistance

LIRAP Heat  
LIRAP Senior/Disabled  
Outreach

### Emergency Assistance

LIRAP Emergency Share  
COVID-19 Hardship

### Rate Discount

Senior/Disabled

### To Be Implemented

Percent of Income  
Payment Plan  
Arrearage Management  
Program

### Conservation Education

Energy Fairs  
Workshops  
General and Mobile  
Outreach

### Energy Efficiency

Low-Income  
Weatherization

## Low-Income Rate Assistance Program (LIRAP)



# Environmental Topics Breakout Room

John Lyons  
Bruce Howard



# Avista's Environmental Footprint

- By 2030, Avista's greenhouse gas emissions fall by 76 percent.
- 2019 Northwest power emissions were 57 million metric tons (Avista is 5.2% of those emissions).
- Power is 20% of all NW greenhouse gas emissions.

## Greenhouse Gas Emissions Forecast

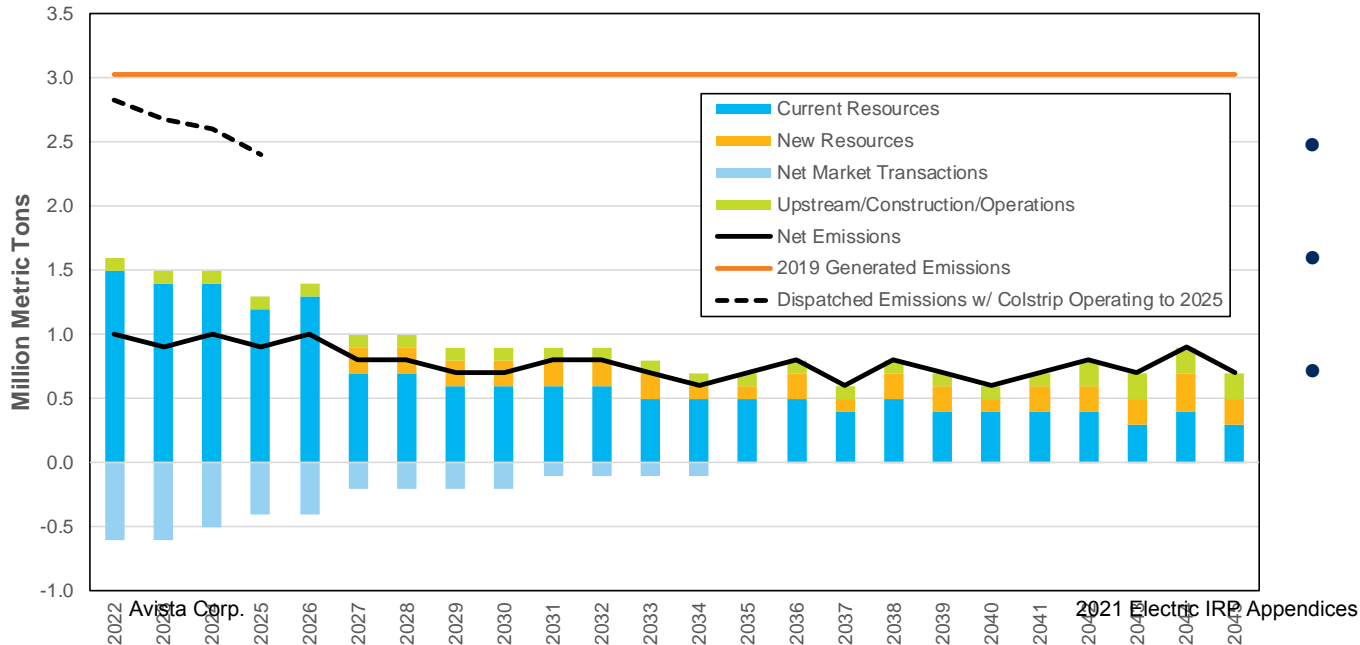

## Total Change in Air Emissions Since 2015

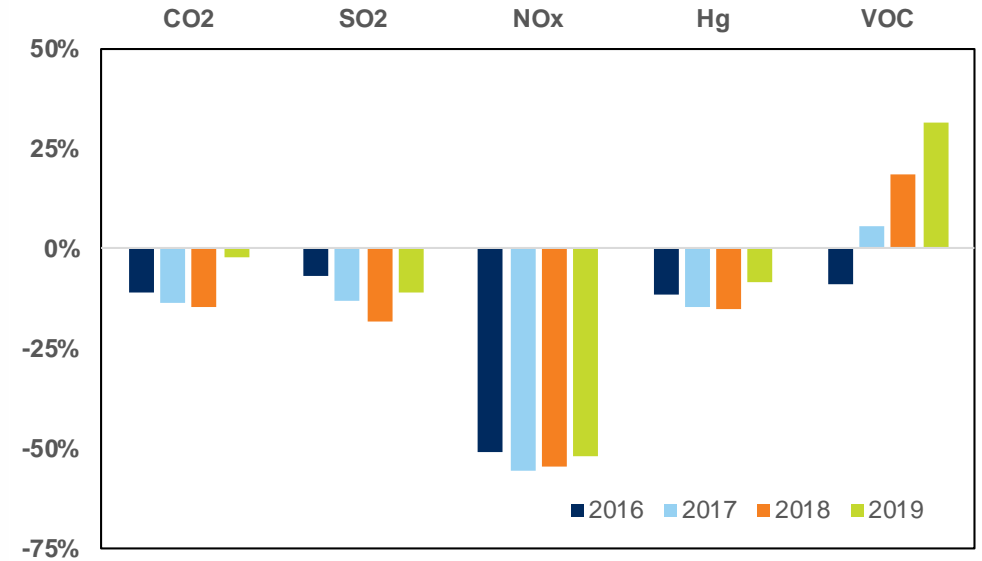

- Total emissions are determined by utilization of facilities and control technology.
- NOx emissions fall by over 50% due to smart burn technology at Colstrip coal fired facility,
- VOC emission rise is due to increased plant utilization and new testing at the Kettle Falls Biomass facility,



# Natural Gas Breakout Room

Tom Pardee  
Michael Whitby  
Jody Morehouse

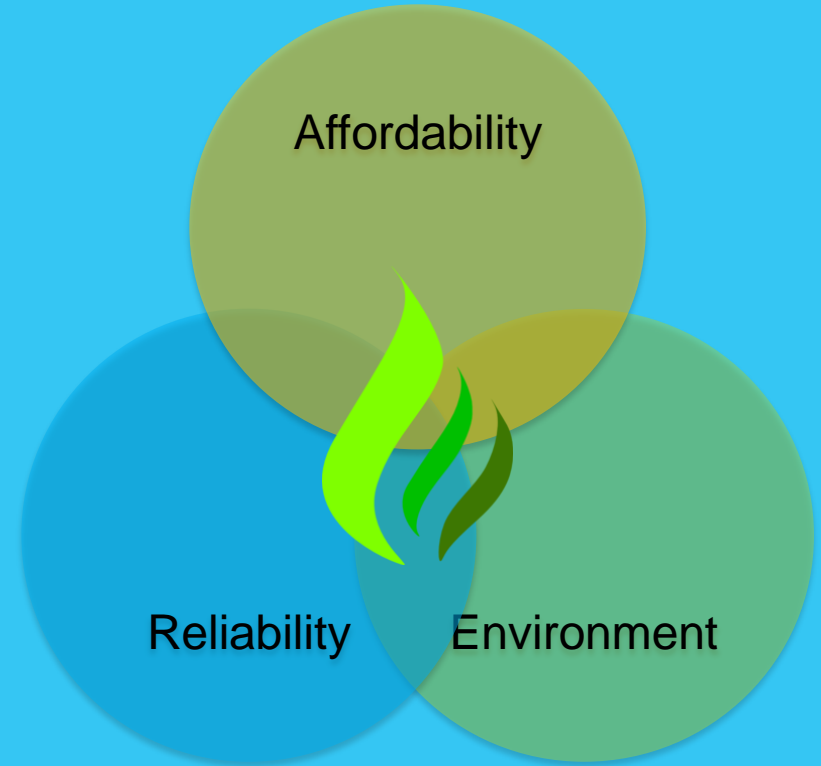

# Carbon Reduction Pathways



## Renewable Natural Gas (RNG)

- Biogas from decomposing waste streams is captured
- The gas is scrubbed to pipeline quality RNG
- RNG flows through existing natural gas pipelines to end users

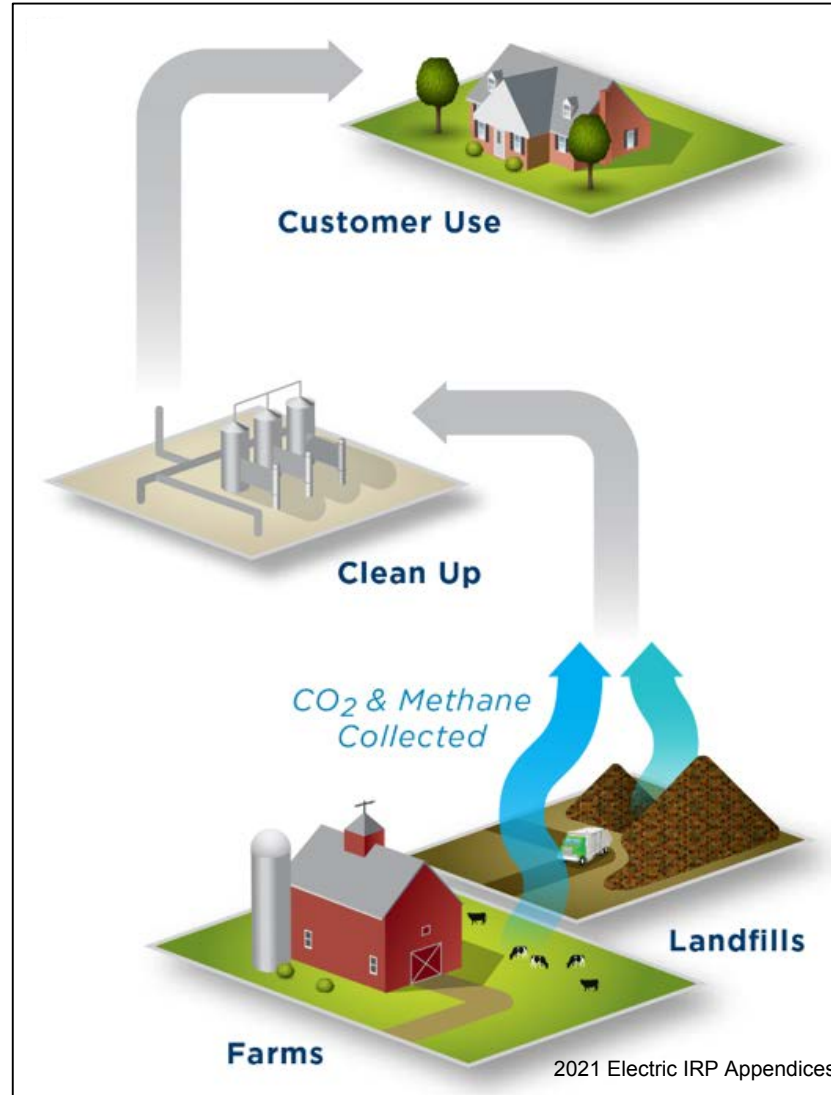

## Power to Gas with Hydrogen

- Renewable electricity converts water to hydrogen
- Hydrogen is combined with waste CO<sub>2</sub> to make RNG
- RNG flows through existing natural gas pipelines to end users

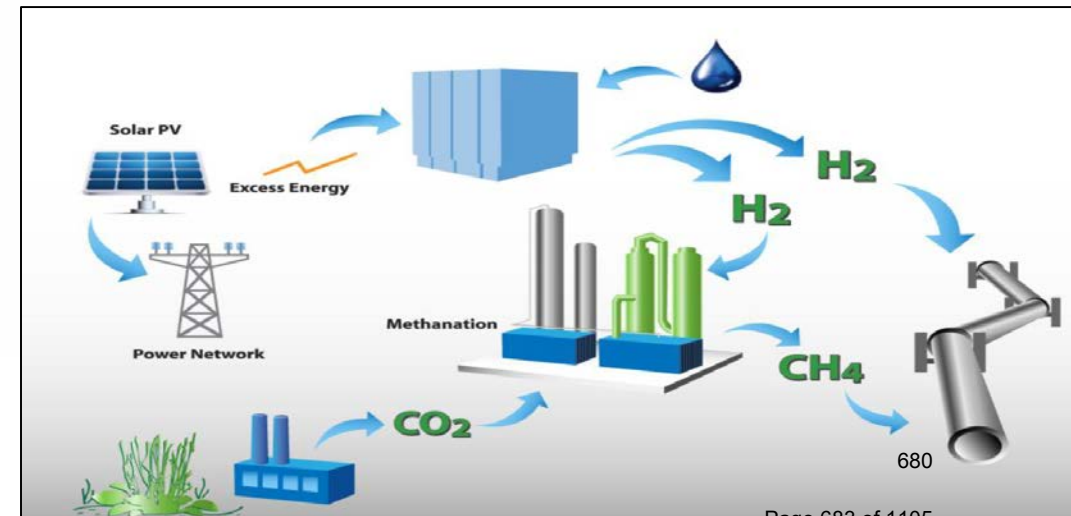

## Natural Gas is Critical to a Clean Energy Future



- In the right applications, **direct use of natural gas is best use**
- Natural gas generation provides **critical capacity** as renewables expand until utility-scale storage is cost effective and reliable
- Full electrification can lead to **unintended consequences**:
  - Creates new generation needs that can increase carbon emissions
  - Drives new investment in electric distribution infrastructure, causing bill pressure
  - Home and business conversion costs borne by customers
  - Puts at risk energy **reliability and resilience, energy choice, and affordability**
- Customers have paid for a vast pipeline infrastructure that can be utilized for a cleaner future by **transitioning the fuel** and keeping the pipe
- A comprehensive view of the energy ecosystem leads to a **diversified approach to energy supply** that includes natural gas



# 2021 Electric Integrated Resource Plan

## Appendix B – 2021 Electric IRP Work Plan





# **Work Plan for Avista's 2021 Electric Integrated Resource Plan**

**For the  
Washington Utilities and Transportation Commission  
&  
Idaho Public Utility Commission**

**April 1, 2020**

## 2021 Electric Integrated Resource Planning (IRP) Work Plan

This Work Plan is submitted in compliance with the Washington Utilities and Transportation Commission's Integrated Resource Planning (IRP) rules (WAC 480-100-238). It outlines the process Avista will follow to develop its 2021 Electric IRP for filing with the Washington and Idaho Commissions by April 1, 2021. Avista uses a public process to solicit technical expertise and feedback throughout the development of the IRP through a series of Technical Advisory Committee (TAC) meetings and uses a combination of social media and public outreach event to include the general public.

The 2021 IRP process will be similar to those used to produce the previous IRPs, but with changes to better align assumptions with the Natural Gas IRP. Exhibit 1 shows the planned 2021 IRP timeline for work products. Avista plans to use Aurora for electric market price forecasting, resource valuation and for conducting Monte-Carlo style risk analyses of the electric marketplace. Aurora modeling results will be used to select the Preferred Resource Strategy (PRS) and alternative scenario portfolios using Avista's proprietary PRiSM model. This tool fills future capacity and energy (physical/renewable) deficits using an efficient frontier approach to evaluate quantitative portfolio risk versus portfolio cost while accounting for environmental laws and regulations. Qualitative risk evaluations involve separate analyses. Avista plans to utilize its proprietary Avista Decision Support System (ADSS) model to conduct analyses to evaluate reserve products such as ancillary services and intermittent generation. Avista also plans to use its Avista Reliability Assessment Model (ARAM) to validate resource adequacy and resource peak contributions (ELCC) as introduced in the 2020 IRP. Avista contracted with Applied Energy Group (AEG) to conduct energy efficiency and demand response potential studies.

Avista intends to use both detailed site-specific and generic resource assumptions in development of the 2021 IRP. The assumptions will utilize Avista's research of similar generating technologies, engineering studies, and the Northwest Power and Conservation Council's studies. Avista will rely publically available data to the maximum extent possible and provide its cost and operating characteristic assumptions publically. The IRP may model certain resources as Power Purchase Agreements (PPA) rather than Company owned because these third party provided resources are more likely to be lower cost.

Avista intends to create a PRS using market and policy assumptions based on the results of newly implemented rules from the Clean Energy Transformation Act (CETA) for Washington and using the least cost planning methodology in Idaho. The plan will also include sections outlining the key components of the Washington Clean Energy Action Plan and an Idaho Preferred Resource Strategy. The IRP will include a limited number of scenarios to address alternative futures in the electric market and public policy. TAC meetings help determine the underlying assumptions used in the IRP including market scenarios and portfolio studies. Although, Avista will also engage the general public using social media and a public outreach event. The IRP process is very technical and data intensive; public comments are welcome and we encourage timely input and participation for inclusion into the process so the plan can be submitted according to the proposed schedule in this Work Plan. Avista will make all data available to the public *except* where it contains market intelligence or proprietary information. The planned schedule for this data is shown in Exhibit 2.



Avista intends to release data prior to its discussion at its Technical Advisory Committee Meetings and expects any comments within two weeks after the meeting.

The following topics and meeting times may change depending on the availability of presenters and requests for additional topics from the TAC members. This shortened IRP cycle will only include five public meetings. The timeline and proposed agenda items for TAC meetings follows:

- **TAC 1: Thursday, June 18, 2020:**
  - TAC meeting expectations and IRP process overview,
  - Review of 2020 IRP Idaho acknowledgement,
  - Update on CETA rulemaking process,
  - Modeling process overview, including Aurora, ARAM, ADSS, PRiSM, and assumption overview,
  - Generation options (cost, assumptions, ELCC),
  - Highly impacted community discussion (WA- CETA).
  
- **TAC 2: Thursday, August 6, 2020 (joint with Natural Gas IRP TAC):**
  - Demand and economic forecast,
  - Conservation Potential Assessment (AEG),
  - Demand Response Potential Assessment (AEG),
  - Natural gas market overview and price forecast,
  - Regional energy policy update,
  - Gas/Electric coordinated studies,
  - Highly impacted community proposals.
  
- **TAC 3: Tuesday, September 29, 2020:**
  - IRP Transmission planning studies,
  - Distribution planning within the IRP,
  - Discuss market and portfolio scenarios,
  - Existing resource overview,
  - Electric market forecast and scenarios.
  
- **TAC 4: Tuesday, November 17, 2020:**
  - Final resource needs assessment and resource adequacy,
  - Ancillary services and intermittent generation analysis,
  - Review draft resource plans for each state and scenarios.
  
- **TAC 5: Thursday, January 21, 2021:**
  - Review draft IRP,
  - Final state resource plans and scenarios,
  - Draft Clean Energy Implementation Discussion,
  - 2021 IRP Action Items,
  - Initial comments from TAC participants.
  
- **Public Outreach Meeting, February X, 2021**

## *2021 Electric IRP Draft Outline*

This section provides a draft outline of the expected major sections in the 2021 Electric IRP. This outline may change based on IRP study results, CETA rulemaking, and input from the TAC.

- 1. Executive Summary**
- 2. Introduction, Stakeholder Involvement, and Process Changes**
- 3. Economic and Load Forecast**
  - a. Economic Conditions
  - b. Avista Energy & Peak Load Forecasts
  - c. Load Forecast Scenarios
- 4. Existing Supply Resources**
  - a. Avista Resources
  - b. Contractual Resources and Obligations
- 5. Energy Efficiency Potential Study**
- 6. Demand Response Potential Study**
- 7. Long-Term Position**
  - a. Reliability Planning
  - b. Resource Requirements
  - c. Reserves and Flexibility Assessment
- 8. Transmission Planning**
  - a. Overview of Avista's Transmission System
  - b. Future Upgrades and Interconnections
  - c. Transmission Construction Costs and Integration
  - d. Merchant Transmission Plan
- 9. Distribution Planning**
  - a. Overview of Avista's Distribution System
  - b. Future Upgrades and Interconnections
- 10. Supply Side Resource Options**
  - a. New Resource Options
  - b. Avista Plant Upgrades
- 11. Market Analysis**
  - a. Wholesale Natural Gas Market Price Forecast
  - b. Wholesale Electric Market Price Forecast
  - c. Scenario Analysis
- 12. Washington- Clean Energy Action Plan**
  - a. Preferred Resource Strategy
  - b. Highly Impacted Community Analysis
- 13. Idaho- Preferred Resource Strategy**
  - a. Preferred Resource Strategy
- 14. Portfolio Scenarios**
  - a. Resource Selection Process
  - b. Efficient Frontier Analysis
  - a. Portfolio Scenarios
  - b. Resource Avoided Cost
- 15. Action Plan**

**Draft IRP will be available to TAC members on January 4, 2021.** Comments from TAC members are expected back to Avista by March 1, 2021. Avista's IRP team will be available for conference calls or by email to address comments with individual TAC members or with the entire group if needed.

---

### **Exhibit 1: 2021 Electric IRP Timeline**

---

<b><u>Task</u></b>	<b><u>Target Date</u></b>
Identify Avista's supply resource options	May 2020
Finalize natural gas price forecast	June 2020
Finalize demand response options	July 2020
Finalize energy efficiency options	July 2020
Update and finalize energy & peak forecast	July 2020
Finalize electric price forecast	August 2020
Transmission & distribution studies due	August 2020
Determine portfolio & market future studies	August 2020
<b>Due date for study requests from TAC members</b>	<b>August 1, 2020</b>
Finalize PRiSM model assumptions	September 2020
Simulate market scenarios in Aurora	September 2020
Portfolio analysis & reliability analysis	October 2020
Present portfolio analysis to TAC	November 2020
<b>Writing Tasks</b>	
File 2021 IRP Work Plan	April 1, 2020
Internal draft released at Avista	December 4, 2020
External draft released to the TAC	January 4, 2021
<b>Comments and edits from TAC due</b>	<b>March 1, 2021</b>
Final editing and printing	March 2021
Final IRP submission to Commissions and TAC	April 1, 2021

---



---

### **Exhibit 2: Public Data Release Schedule**

---

<b><u>Task</u></b>	<b><u>Targeted Release</u></b>
Supply Side Resource Options	June 2020
Conservation Potential Study Data	July 2020
Demand Response Potential Study Data	July 2020
Peak & Energy Load Forecast	July 2020
Wholesale Natural Gas Price Forecast	August 2020
Wholesale Electric Price Forecast	September 2020
Transmission Interconnect Costs	September 2020
Existing Resource Data	September 2020
<b>Annual Capacity Needs Assessment</b>	<b>November 2020</b>

---

# 2021 Electric Integrated Resource Plan

## Appendix C – Public Participation Comments



## Appendix C: Public Participation Comments

### IRP Comments Provided by Technical Advisory Committee Members

Committer	Comment	Avista Response
Idaho Conservation League	<p>System wide vs state specific resource additions</p> <ol style="list-style-type: none"> <li>1. We request Avista compare the results of this Idaho-specific study to the results of the same analysis at the system-wide level.</li> <li>2. We request Avista compare the results of this Idaho-specific study to the results of the same analysis at the system-wide level.</li> <li>3. We also request a study that documents the costs to implement, monitor and document the state-specific addition of resources to an interconnected system dispatched to meet combined customer loads.</li> </ol>	<ol style="list-style-type: none"> <li>1. Avista included a scenario in Chapter 12 with 100% clean energy by 2045.</li> <li>2. Avista split resources and costs between its jurisdictions to understand the effect to each state.</li> <li>3. All costs to meet resource requirements by state is included in the PRISM model. The model is publicly available in Appendix I. Also, summary level information is provided in the IRP Chapter 11 and 12.</li> </ol>
Idaho Conservation League	<p>Existing Resources</p> <ol style="list-style-type: none"> <li>1. We request Avista study a scenario that applies the Social Cost of Carbon to all resources, including those that serve Idaho, as offered in the first TAC meeting.</li> <li>2. We request Avista study scenarios for Colstrip costs that reflect the changing ownership shares currently being considered by co-owners Puget Sound Energy, Northwestern Energy, and Talen. Further, we request a study of likelihood and scale of increases to Avista's share of common plant costs, remediation costs, and fuel supply costs, including minimum fuel supply and generation off-take, attributable to both the closure of Units 1 and 2 and the changing ownership share of Units 3 and 4.</li> <li>3. We request a study of the accuracy of Avista wholesale natural gas price forecasting methodology by comparing forecasted prices in prior IRPs to prices Avista actually paid. We request this study include a comparison of the accuracy of consultant-supplied forecast to publicly-available forecasts covering the same time periods.</li> </ol>	<ol style="list-style-type: none"> <li>1. Avista conducted this study and it is available in Chapter 12.</li> <li>2. Regarding the change in ownership percentages for Units 3 and 4, there are no changes to Avista's responsibilities or modeling inputs to alter because Avista's 15 percent share of both units remains static under the Colstrip ownership agreement. Avista's financial responsibility for the plant remains the same regardless of the non-Avista ownership or ownership percentages for Units 3 and 4. As in the last IRP, Avista is accounting for the shift (increase) in previously shared costs that are a result of the closure of units 1 and 2. Those costs increased, but Avista's share of those costs did not change. Avista has zero responsibility for the remediation costs associated with Units 1 and 2. The closure of those units did not end the financial responsibility of those remediation costs for the owners of those units (Puget Sound Energy and Talen). Avista's fuel contract is separate from the contracts that supplied Units 1 and 2. Avista's fuel contract and any subsequent mine remediation costs with our share of coal are already included in the prices being modeled in the 2021 IRP, consistent with past IRPs.</li> </ol>

		<p>3. The natural gas price forecast beyond the shorter term forward markets is always an area of concern because of the potential for volatility, timing and magnitude of outside events, much like the current pandemic we are now experiencing. It is in our own best interests to use good forecasts. Avista publishes its natural gas price forecasts in each IRP; including both consultant forecasts on an annual average basis. Actual natural gas prices are also publicly available. The consultants that we use work on a national as well as an international basis. They already perform their own internal analyses to make their forecasts as accurate as possible to maintain and grow their business. We are paying for their expertise and research into the natural gas market. Avista has not seen any evidence indicating that there are better forecasts available and we do not possess the resources to develop comprehensive fundamentals based natural gas forecast on our own. Some forecasts, like those provided by the Energy Information Administration, supply some more details about the fundamentals they are using, but they are also more dated and do not provide the level of granularity into specific trading hubs. These consultants would not be able to remain in business if they had to give away all of their research for free. Please let us know if you have found other evidence or research indicating better forecasts. Avista includes the natural gas prices used in the forecast in Appendix I.</p>
<p>Idaho Conservation League</p>	<p>Storage</p> <ol style="list-style-type: none"> <li>1. We request Avista model loads and generation at the sub-hourly level. We recognize Avista began pursuing sub-hourly modeling in the 2017 IRP and further refined the ADSS system in the 2019 IRP. We request Avista fully implement sub-hourly modeling for all IRP studies and processes.</li> <li>2. We request Avista study the optimal pairing of generation resources with storage of different technologies and lengths of supplying services. For example: pairing local solar or wind with Li-Ion 4hr, 6hr, and 12hr batteries; pairing pump hydro resources with regional solar, wind, and wholesale markets; pairing long term storage like hydrogen electrolysis and</li> </ol>	<ol style="list-style-type: none"> <li>1. Sub-hourly modeling is challenging due to model solution complexity and data availability. Further, modeling all sub-hourly periods is not technologically possible. Presently, modeling at one-hour granularity requires thousands of hours of computer processing time. Moving to intra-hour modeling would cause an exponential increase in solution time even if the data was available. ADSS and other modeling techniques are used to evaluate intra-hour values, and generally rely on sampling of relevant time periods. This is specifically the case with the complexity of modeling storage resources. Avista is working on this issue and is hopeful it will be available in future IRPs and will be added as an Action Item in the 2021 IRP if not completed for this plan.</li> <li>2. As described in the first TAC meeting and distributed to the TAC afterwards and publically available on our website, this</li> </ol>

	<p>associated hydrogen storage with Avista’s own resources and wholesale market generation.”</p> <p>3. We request Avista study the emission reductions possible from pairing storage with specific clean generation options along with the Proposal presented to the TAC to apply the average emissions rate of the region for storage paired to generic wholesale market resources.</p>	<p>IRP already includes a wide variety of stand-alone storage and combined renewables plus storage options. The options being modeled include distribution scale 6-hour Lithium-ion; 4- , 8- and 16-hour Lithium-ion; 4-hour Vanadium flow, 4-hour Zinc Bromide flow batteries; 16-hour 100 MW share pumped storage; and 100 MW solar photovoltaic with Lithium-Ion batteries. Avista is also modeling hydrogen using fuel cells or converted combustion turbines. Each of the hydrogen options will include long duration storage facilities as a backup to real-time deliveries. Avista’s IRP modeling includes the benefits from a portfolio optimization in its current process between storage and renewable resources.</p> <p>Avista acknowledges there could be a benefit to pairing storage with renewables from a transmission perspective. The economic estimates of the IRP are exclusive of T&amp;D investments. Although the locational benefits of storage paired with resources may not be optimal when considering other “better” locations to locate the storage. Avista agrees with this concept and is trying to determine the best methodology to model these potential benefits, but the modeling of this concept may not be available in time for this IRP. It will be added as an Action Item if we are not able to develop the concept and include it in the 2021 IRP.</p> <p>3. Avista includes regional emissions for storage not connected to a facility; for paired resources, Avista does not include the emissions when using the paired resources. Although, over time as paired solar/storage resources are no longer obligated to use the paired resources storage technology to satisfy tax credit requirements will likely use a combined grid/local power for optimization of the system. [Avista’s PRS did not include storage emissions, but scenarios were conducted to understand this effect].</p>
<p>Idaho Conservation League</p>	<p>Distribution Level Modeling</p> <p>1. To help encourage the optimal growth of DERs on the Avista system, we request a Hosting Capacity Analysis. This analysis could support a distributed energy resource interconnection map that identifies where distributed energy resources exist on the system or</p>	<p>1. Avista’s transmission and distribution departments are working on a public process for this type of planning. This process will likely be separate from the IRP process, but will inform the IRP. More details of this process and its findings will be shared with the TAC as they develop.</p>

	<p>where the distribution system is constrained and could benefit from energy storage or specific demand responses. This Hosting Capacity Analysis would benefit the IRP's load forecasting and overall integration of distributed energy within the IRP. We recommend Avista define DERs broadly for this study to include: customer-sited generation and storage, utility-sited generation and storage at substations or other locations on the distribution grid, as well as public and private electric vehicle charging stations.”</p> <p>2. We request Avista incorporate different load shapes that are indicative of customer generated power as well as the charging of electric vehicles to ensure accuracy in the load shapes for supply-side resource planning. The Smart Electric Power Alliance has an informative set of resources to help with this effort:  <a href="https://sepapower.org/knowledge/proposing-a-new-distribution-system-planning-model/">https://sepapower.org/knowledge/proposing-a-new-distribution-system-planning-model/</a>.”</p>	<p>2. Avista welcomes the information, but at this time is using data collected from its local system for both solar photovoltaics and electric vehicles.</p>
Idaho Conservation League	<p>Flexibility Issues</p> <p>1. With the technological changes of a modern grid system, including flexibility in both supply and demand studies is essential as we look to the future of electric service areas. As shown in the pilot program with the Catalyst Building, the savings from energy efficiency and flexible building loads can be extremely beneficial for the electric grid as a whole. Similarly, the micro-transaction grid project in the Spokane University District is demonstrating the value of flexible loads and new market opportunities for customers to manage their power bills. To fully explore the value that flexibility brings to Idaho customers, we request Avista study the potential to expand similar projects in the Idaho service territory. At minimum, a study to see the perspective of customers' willingness to participate in such a pilot program could have lasting results.</p>	<p>1. Avista appreciates the comment to also consider Idaho as a test bed for future projects and will take this under advisement. Avista utilizes the University of Idaho for several R&amp;D efforts through a competitive grant process for a total of \$270,000 to study efforts related to energy efficiency and flexible building loads. Example projects from the 2019/20 academic year include: a program design for energy trading system for consumers, using infrared cameras for building controls and gamification of energy use.</p>
Idaho Conservation League	<p>Climate Change Impacts to Avista's System and Costs</p> <p>1. Loads - study changes to both long-term load forecast and the peak load forecast attributable to climate change. The 2020 IRP mentions a 1-degree increase in temperatures, but does not appear to describe how</p>	<p>1. Climate change is being included in the load forecast as a scenario, which was covered in the special TAC meeting on August 8, 2020 after receiving this letter. Further, all load forecast scenario data is available on the IRP website (Appendix I). Please let us know if you have any additional</p>



	<p>climate change is factored into the peak load forecast. The 2020 IRP also cites a temperature data set from 2013, which we recommend Avista update to the most currently available set.</p> <ol style="list-style-type: none"> <li>2. Hydro - study the potential changes to hydroelectric power generation that could result from climate-caused changes to precipitation type and timing. This study should document the range of impacts to power costs that result from the changes in hydroelectric power generation.</li> <li>3. Thermal plants - study potential changes to expected generation and production costs due to temperature changes. This study should include changes to expected generation and fuel costs as output varies with ambient temperatures and the impacts to cooling water needs due to changes in precipitation and water temperatures. The study should document the range of impacts to power costs due to the change in expected generation output, fuel needs, and cooling water needs.”</li> </ol>	<p>questions or concerns that may have arisen since that presentation.</p> <ol style="list-style-type: none"> <li>2. We have obtained the climate adjustments developed by the Power Council and included a scenario with these adjustments in Chapter 12.</li> <li>3. Avista agrees temperature changes will impact the amount of production from its natural gas-fired facilities. This impact will be included in the climate change scenario.</li> </ol>
Idaho Conservation League	<p>Beneficial Electrification</p> <ol style="list-style-type: none"> <li>1. The load forecast includes the baseline projection of electric charging services, as forecasted in the 2020 TEP. We also request scenarios that consider higher penetration of EV, especially for commercial fleets, delivery vehicles, and public transportation.</li> <li>2. A study of how to optimize charging behaviors, including customer load management, and how to optimize the location of public and workplace charging stations to avoid distribution grid overload while maximizing grid flexibility and benefits to the system. For example, the TEP identified that the \$1,206 in electric system benefits per EV could “be increased by another \$463 per EV when load management shifts peak loads to off-peak.”</li> </ol>	<ol style="list-style-type: none"> <li>1. Avista studied increasing EV penetration in the 2020 IRP. At this time, Avista needs to focus on other scenarios for this IRP because of the limited amount of time available for modeling.</li> <li>2. Avista is updating its EV and demand response program assumptions and this will be discussed at the September TAC meeting. Avista welcomes this discussion at the upcoming meeting to ensure it has robust assumptions for this IRP.</li> </ol>
Climate Solutions	<p>Climate solutions provided additional information regarding ductless heat pumps and water heater heat pumps. This is in regards to the electrification scenarios. See attached letter in Appendix C- “Climate Solutions- Electrification End Use Efficiency Comments.pdf”.</p>	<p>Avista adjusted a portion of the end use load for the electrification. Further detail regarding these comments are included in Appendix C- “Climate Solutions Email Response.pdf”</p>

<p>Northwest Power &amp; Conservation Council</p>	<p>Preliminary market price forecasts for the 2021 Power Plan diverge from the pricing regime shown in this draft IRP. While understanding the underlying cause of that divergence would take a deep dive into our respective AURORA runs, given our work thus far we would expect that it's related to allowing AURORA to construct new natural gas generation outside the Northwest to replace expected retirements in the WECC thermal generation fleet (and the associated volume of those retirements).</p> <p>We were given guidance from the Council and from our advisory committees to limit the potential for new natural gas generation both inside and outside the region. In doing so, we see a wave of solar and wind generation construction that depresses future market prices substantially lowering them from prices seen today. While this is largely outside of the control of the region, it presents substantial risk to regional utilities making decisions consistent with market prices that assume natural gas resources will set the marginal price.</p> <p>We'd encourage all the utilities in the Northwest, including Avista, to test any IRP-based decisions against an aggressively low market price forecast. Many things are uncertain about the future of the power system in the WECC. We would not want to represent any forecast, including our own, as certain. But we do think it's a risk to consider and one that will be developing rapidly over the next few years.</p> <p>While we're still working on the 2021 Power Plan, we'd be happy to share an AURORA archive file of the work done to date.</p>	<p>Avista is concerned wholesale prices going forward will be extremely volatile, more than Aurora can quantify, much of this volatility will depend on how much and whether capacity resources will be developed or not. It is appropriate to understand the risk of higher and lower prices. From analysis in the short term, Avista's price forecasts are too low- specifically not including risk premiums we are seeing from resource adequacy issues we are seeing. Although, in the long run there is significant downward risk with more renewables- The future will depend on how far policy makers will take goals and ambitions to actual operations and construction.</p> <p>There will also likely be a feedback loop as well- such as changes in loads (both industrial losses and electrification opportunities and political changes due to ramifications of policy changes) and storage opportunities. Its possible storage could be key in keeping prices from getting too low- but that will depend on future costs of that technology. In the end there is a number of paths the future may take us and its really an issue of how much time should we make to look at the region versus our portfolio. The way things are trending there should be more focus toward our portfolio then market prices.</p> <p>In this case the real risk of having too low of forecast for prices could have an effect of less acquisition of EE, but in the end with our requirements of having clean energy and capacity- the price forecast really only impacts a solar vs wind decision- but so far wind is winning that decision due to capacity requirements and over reliance of solar elsewhere; then they question of should we build natural gas or storage- that decision is likely a matter of carbon pricing at this point. So where I'm going is and have been pondering for some time do price forecasts really matter for resource planning- given we have fewer resources to choose from and specific requirements to meet. For example, the energy price used to be a major component of our EE avoided cost- now the highest component is social cost of carbon and non-energy benefits- its seems the world has shifted from energy price forecasts.</p>
<p>Northwest Power &amp;</p>	<p>Comments are included in the comment box of the draft IRP pdf. These comments are attached in "Avista 2021 Draft</p>	<p>Avista made numerous additions and corrections to comments provided by the Council.</p>

Conservation Council	Electric IRP_councilstaff.pdf” Most comments were regarding providing additional context for statements	
Rye	<p>Seek further information regarding modeling and assumptions for pumped storage</p> <ul style="list-style-type: none"> <li>○ “State of Charge” assumed (table 9.12)? <ul style="list-style-type: none"> <li>▪ Table 9.12 indicates an 8-hour pumped storage project would only contribute 30% to Avista’s peak capacity need and a 12-hur project would contribute 58%. These are much lower than Swan Lake and Goldendale would expect and drastically lower than those used by other NW utilities</li> <li>▪ Swan Lake and Goldendale believe Avista is using a very low state of charge possibly 20% (pond fill). This doesn’t align with the operational realities associated with operating hydro or pumped storage facilities.</li> <li>▪ Import assumptions during off-peak hours in the winter should be re-visited, given that these would be key hours when long-duration storage would charge for the winter on-peak reliability</li> <li>▪ Swan Lake and Goldendale recommend that Avista consider optimizing the dispatch of their resource over a wide time window (1-2 weeks) allowing for greater flexibility and minimizing the need for daily charging/recharging</li> </ul> </li> <li>○ What duration of useful life?</li> <li>○ Was the Swan Lake project specifically considered?</li> </ul>	<p>Avista met with Rye through a conference call on February 24<sup>th</sup>, 2021 to discuss their comments</p> <ul style="list-style-type: none"> <li>• Avista modelled several northwest pumped hydro projects in the 2021 IRP; including Swan Lake and Goldendale, based on publicly available data. Avista believes some of these comments could be derived from the 2020 IRP.</li> <li>• Avista acknowledges Rye’s comment regarding re-charging capacity during off-peak hours. Avista disagrees with Rye that it can fully recharge a storage devise during off-peak hours of a northwest system peak event beyond the limits already included.</li> <li>• Pumped hydro is optimized on a 1 year basis and not 1 to 2 weeks.</li> <li>• Avista uses a 50-year life to amortize capital costs.</li> </ul>
Rye	<p>Avista should not seeks to construct new gas facilities</p> <ul style="list-style-type: none"> <li>• Given the state of Washington policy, Swan Lake and Goldendale request that Avista provide a detailed explanation for why a new gas resource would meet one of the few and limited CETA provisions allowing construction of such resources, particularly including violation of reliability standards and, if violations are possible, whether pumped storage could help alleviate or solve those potential violations.</li> </ul>	<p>Avista specifically modelled the availability of both Swan Lake and Goldendale in its PRiSM model. Given information available, these projects were not cost effective compared to natural gas. Avista’s IRP is an indication of cost-effective resources, but a future request for proposals (RFP) will determine the most cost-effective resource acquisition.</p>

Rye	<p>Advocate that Avista issue a capacity RFP (strongly support)</p> <ul style="list-style-type: none"> <li>• Swan Lake is expected to achieve commercial operation in late-2026</li> <li>• Only accurate way for Avista to fully evaluate potential pumped storage projects including various pricing information, timing for construction and whether the operating characteristics align with Avista's needs</li> </ul>	Avista may release an RFP in late 2021 or early 2022 for its 2026 need.
Renewable Northwest	We recommend the Company review the data informing the leveled cost (\$/kW) for the preferred 4-hour lithium-ion battery, as there appears to be a gradual price increase after 2033 rather than a steady decline, which would be expected.	Avista aligned its storage prices with bids received during its renewable RFP. Further, Avista also used publicly available studies for its future cost curves. One difference between our forecasted cost could be they are in nominal dollars rather than "real" dollars. Avista's storage costs are expected to decline significantly in "real" terms. Avista also recommends any suggestions regarding costs of resources come earlier in the process. Avista included these costs in its TAC meetings and posted all its cost information on its website six months prior to the draft IRP was made available.
Renewable Northwest	We recommend the use of the PLEXOS model to simulate generation on a sub-hourly timescale to calculate the balancing reserve requirements and the associated system costs and benefits to meet those intra-hourly dispatch requirements, as legally enforced through NERC's BAL series standards.	Avista is planning public process to evaluate both integration and ancillary services costs using its ADSS system. This process will begin in 2021 Q2. Also Avista is considering Plexos for potential reliability studies and other work, but has not acquired the model at this time.
Renewable Northwest	We recommend Avista study for its final IRP the different operational configurations and characteristics of hybrid resources and standalone storage to correctly evaluate the resource ELCC value.	Avista plans continue studying these resources in this IRP and the next. Avista disagrees with using alternative ELCC values for storage resources based on its analysis of its system. Specifically, Avista is concerned with relying on short duration storage in winter months because of its high winter energy needs, lack of reliable market power in critical events for recharging the system, and high largest single contingency units.
Renewable Northwest	For the Commission and stakeholders to better understand why Avista's capacity needs can only be met with new natural gas peaking capacity, we recommend that Avista provide at its upcoming TAC meeting or publish in its final IRP a projected loss-of-load event, displaying by hour where there is a deficiency in available capacity. This could be in the form of a 12x24 matrix of the peak demand or	Avista's current resource adequacy model does not report the information required to develop the 12x24 matrix. Avista agrees this could be a useful exercise and will consider developing this report in the next IRP as it continues to review ELCC studies.

	hours with the highest loss of load probability which were used to calculate the ELCC values for all resources.	
Renewable Northwest	We recommend the Company conduct one additional analysis to better understand how policy-driven changes in Avista's resource mix should impact the way the Company plans for meeting demand reliably and at least cost.	Avista agreed to conduct another portfolio scenario named 5B to remove Colstrip in 2022 (just as with the PRS) and follow the other logical requirements of the Portfolio 5. This portfolio is the 100% clean energy portfolio by 2045.
NW Energy Coalition	The preferred portfolio continues to develop energy efficiency and begins to lay out a strategy for acquiring demand response resources, although we believe the targets can be increased and the pace can be accelerated. The treatment of new renewable resources is somewhat more mixed, as described below. Finally, significant improvement is needed for both the cost and capacity value battery and pumped storage.	Demand response and new rate designs are a significant part of Avista future. Avista agrees some programs will take time to ramp up to large savings and some rate restructuring programs will take time to develop and get approval through multi-jurisdictions.  Regarding battery & pumped hydro, Avista continues to use the best information publicly available for these resources. Avista even specifically modeled many of the Northwest proposed projects. Avista also recommends any suggestions regarding costs of resources come earlier in the process. Avista included these costs in its TAC meetings and posted all its cost information on its website six months prior to the draft IRP was made available.
NW Energy Coalition	We believe further analysis will show that there are substantial available and cost-effective clean energy resources that can defer or eliminate this new emitting resource.	Avista hopes to find these resources in a future RFP as costs for these emerging technologies decline.
NW Energy Coalition	The IRP analysis states "construction and operational greenhouse gas emissions are considered and priced using the SCC", but that the SCGHG was not applied to market purchases and sales in the PRS as done previously. The reason for the change from previous practice is not clear.	Avista is providing additional detail regarding this topic in the IRP document. In summary, after consultation with WUTC policy staff, Avista chose not to include the SCGHG/SCC as part of the market transactions specially because the CETA does not require these costs for short term transactions. Avista did conduct a study to see the implication of the change. Avista will discuss this option again in the 2023 IRP process.
NW Energy Coalition	Because of the current and proposed new addition of natural gas generation, we urge Avista to revisit this issue and adjust the upstream methane emissions factor represented in the Social Cost of Greenhouse Gas analysis.	Avista included an adder for methane emissions equal to approximately 10% of the natural emissions directly burned. By including these emissions as part of the social cost of carbon exceeds regulatory requirements in Washington. While upstream methane emissions will always have uncertainty due to life expectancy and the variety of sources, Avista will continue to make the best estimates for these emissions given its fuel sources.
NW Energy Coalition	The question we pose is whether a staged approach to capacity need could provide a balanced 2027 resource	Avista appreciates this comment and finds IRPs are a bit of a challenge compared to actual acquisition of resources since IRPs

	<p>portfolio that is better aligned with CETA policy guidance while meeting reliability needs cost-effectively. The first stage involves maximizing the availability of so-called “energy limited” clean flexible resources, including demand response and storage. These are generally considered to provide capacity value of 4 hours duration and should suffice for meeting needs during typical peak periods. In the second stage, meeting rare long-duration peaks requires supplemental resources. The draft IRP suggests that new peakers can meet these supplemental needs. But once these very expensive and high-emitting new peakers are put into the resource mix, the IRP models will dispatch them not only for very infrequent long duration high peaks, but much more often across the year because they are now “existing” resources. As a result, these new peakers will displace less expensive, non-emitting resources. This creates a lost opportunity for CETA compliant clean energy resources.</p>	<p>do not account for existing resources available in the marketplace. Specifically the options to acquire resources for a 5 to 10 year period will allow for a staged acquisition of cleaner resources that may potentially become available in the 2030s. While the IRP does a great job at evaluating new resources this shortcoming means IRPs will always identify a resource mix that may differ from the actual resource acquisitions obtained through an RPF or another competitive bidding process. Avista anticipates significantly more cost effective cleaner resource options will be available as it acquires new resources.</p>
NW Energy Coalition	<p>The CPA summarizes the technically achievable potential for DR at 90 MW in 2025 (about 5.1% of peak load) and 170 MW in 2045 (almost 10% of peak). NWECA agrees that this is a reasonable magnitude for total potential, but we believe it can be achieved considerably faster.</p>	<p>Avista uses ramp rates provided by Applied Energy Group to add demand response. Avista modeled these programs to be available to begin in any year and optimized our system over the full 24 years. Beginning programs earlier will add cost to customers prior to resource need.</p>
NW Energy Coalition	<p>However, the future costs for batteries and pumped storage simply don't seem reasonable. The values in Figure 9.1 show slight declines in battery costs, and then flat or rising costs through the remainder of the planning horizon. Most other estimates show consistently declining costs through the coming decades, though at varying rates.</p>	<p>Regarding battery and pumped hydro, Avista continues to use the best information publicly available for these resources. Avista even specifically modeled many of the Northwest proposed projects. Avista also recommends any suggestions regarding costs of resources be submitted to the Company earlier in the process as they're more likely to be able to be included. Avista included these costs in its TAC meetings and posted all of its cost information on its website six months prior to the draft IRP being made available.</p>
NW Energy Coalition	<p>There are at least two pumped hydro projects with a reasonable chance of commercial operation by 2027, and further specific project assessment would be useful.</p>	<p>Avista specifically modeled these projects and they were not found to be cost effective compared with a new natural gas peaker.</p>
NW Energy Coalition	<p>As Avista proceeds towards the 2021 capacity RFP, we encourage revisiting this key issue. Hybrid resources could provide a significant capacity benefit and defer the need for new gas peakers, as well as make more effective use of limited available transmission capacity for renewables and provide more operating flexibility.</p>	<p>Avista expects hybrid resources to be bid in future RFPs and will conduct further ELCC analysis to ensure proper peak credits of these resources so Avista customers have a reliable system.</p>

WUTC Staff	<b>Clean Energy Action Plan</b> <ul style="list-style-type: none"> <li>• Add a table to the CEAP that includes year-over-year capacity of all planned resources, including demand response.</li> <li>• Include planned Appendix G with details of about planned transmission and distribution improvements.</li> </ul>	Avista added new tables to Chapter 15 and is including Avista's 10 year transmission plan and its 2019/2020 System Assessment
WUTC Staff	<b>Climate change</b> <ul style="list-style-type: none"> <li>• Provide discussion regarding the implications of possibly moving from a winter peaking utility to a dual or summer peaking utility.</li> </ul>	Avista provided additional detail regarding is climate change analysis in Chapter 3 and Appendix K. Further, Avista modeled a portfolio scenario in Chapter 12, outlining the changes in resource strategy with higher summer load and lower winter load.
WUTC Staff	<b>Load Forecasting</b> <ul style="list-style-type: none"> <li>• Clarify the date in which its economic inputs were finalized.</li> <li>• Discuss any adjustments to the forecast made in response to the ongoing pandemic.</li> <li>• Clarify the high and low load growth ranges used on page 3-14. For example, how did the company settle on the high and low assumptions for annual service area employment and population growth outlined in table 3.3? Please explain.</li> <li>• Discuss the assumptions behind the EV and solar PV forecasts that are inputs into the load forecast.</li> <li>• Clarify which of the two climate change forecasts the IRP uses.</li> </ul>	Avista included updates to Chapter 3 to address these comments.
WUTC Staff	<b>Upstream Emissions &amp; SCGHG</b> <ul style="list-style-type: none"> <li>• Include in the narrative description required by WAC 480-100-620(11) a clear articulation of how the company calculated the SCGHG.</li> <li>• Discuss assumptions about the SCGHG in market purchases and charging storage resources with market purchases.</li> <li>• Explain why 1.0 percent is an appropriate upstream emissions factor for U.S. Rockies natural gas.</li> </ul>	Avista included additional language regarding social cost greenhouse gas analysis in chapters 9 & 11. Regarding the upstream emissions, this is in relation to the Natural Gas IRP.
WUTC Staff	<b>Sub-hourly Modeling Capabilities</b> <ul style="list-style-type: none"> <li>• Clarify storage cost assumptions.</li> </ul>	Avista added additional explanation of storage modeling in Chapter 9.

WUTC Staff	<b>Customer Benefit Provisions in CETA</b> <ul style="list-style-type: none"> <li>Provide a scenario or, at minimum, a narrative regarding possible changes to resource decisions that could increase customer benefit.</li> <li>If available and time permits, incorporate the DOH data in the CIA.</li> </ul>	Avista added a portfolio scenario in Chapter 12 to address the maximum customer benefits. Avista is also planning to engage a consultant to help estimate non-energy impacts for further analysis regarding customer benefits. These changes may be available in the CEIP, but at minimum the 2023 IRP. Unfortunately, the DOH data was not available for the 2021 IRP.
WUTC Staff	<b>Resource Adequacy and Uncertainty</b> <ul style="list-style-type: none"> <li>Clarify the company's peak credit methodology, including the definition of "peak" terms.</li> <li>Explain how the company incorporates uncertainty in the RA assessment.</li> </ul>	Avista added additional detail regarding peak credit analysis in Chapter 9. Regarding the uncertainty of the RA assessment, Avista added information in Chapter 7 using the risk topic discussed in the "Implications of regional resource adequacy program on utility integration resource planning".
WUTC Staff	<b>Public Participation</b> <ul style="list-style-type: none"> <li>Provide an IRP update based on any recent planned resource acquisition.</li> </ul>	Resource selection from the 2020 Renewable RFP was not complete in time for the 2021 IRP. Avista plans to update the WUTC with a new Clean Energy Action Plan if any contracts are signed.
WUTC Staff	<b>Data Disclosure</b> <ul style="list-style-type: none"> <li>Ensure appendices include a record of stakeholder feedback and the company's response.</li> <li>Provide context for the data files provided on the company's website and submit in the docket.</li> </ul>	In addition to this summary, Avista is also including copies of comments from TAC members as well as Q&A and comments from the Company's Public IRP meeting.
WUTC Staff	<b>Natural Gas Design Day (Planning Standard)</b> <ul style="list-style-type: none"> <li>Explain the new design day methodology.</li> <li>Explain why the new design day standard is now the most appropriate one.</li> </ul>	See Natural Gas IRP
WUTC Staff	<b>Renewable Natural Gas</b> <ul style="list-style-type: none"> <li>Include details of RNG cost assumptions in the appendices.</li> </ul>	See Natural Gas IRP
Tyre Energy	We noticed that there was not a Lancaster PPA extension scenario included in the 2021 draft IRP. Why the change from last year?	Avista included the Lancaster PPA extension analysis in the 2020 IRP based on a request by the Idaho Commission staff. For the 2021 IRP, no such request was made until now, so it was not included as a scenario. Given we do not have a firm price for a PPA extension, or any other existing resource, we don't think it would be appropriate to include it in the public IRP. One of my concerns with IRPs, is it is predominantly based on acquiring new resources and often does not or cannot do a good job of illustrating resource choices when existing resources are available. The IRP shows the resource options for new resource choices and does a relatively poor job at studying existing resources since we usually don't have pricing for these options. In



		the end, the IRP is a way to calculate the avoided cost of new generation or demand-side resources. The plan showing a need for new natural gas CTs does not preclude us from acquiring a different resource that is a better solution for customers through an RFP or another acquisition strategy. We have recognized our IRP analysis needs to improve how we review existing resource options and that has been identified as an Action Item for the next IRP to determine the best way to include the potential to extend existing contracts in the IRP.
Tyre Energy	Would you consider revising this draft to include a 10 year Lancaster PPA extension scenario? It seems unlikely to us that choosing not to extend the Lancaster PPA and turning around to immediately add 210+ MW of new peaking capacity in 2027 would be economically advantageous enough (compared to a Lancaster PPA extension scenario) to exclude the extension scenario from the IRP.	Avista believes the IRP illustrates the need for firm capacity, it shows natural gas is a viable option. The decision for an existing plant vs a new facility or any other option is best decided in an RFP rather than an IRP. In the future, if Lancaster should be considered in the IRP, Tyre should provide the IRP team with firm pricing for the resource option.
Tyre Energy	Will you share with us the unit parameters for Lancaster that would be used for a Lancaster PPA extension scenario? We'd like to understand what level of operational flexibility would be assumed in a Lancaster PPA extension scenario.	Avista would like to understand your options to improve flexibility of the machine. As you know we are transitioning to more intermittent resources will require us to have more ramping and start/stop requirements.
Dave Van Herset	Biomass generation option should be included as one of the alternatives evaluated to determine relative economics of the three approved new generation types, wind, solar and biomass here in the Inland Empire. We have the moral obligation to utilize the forests for the benefit of mankind not to fuel forest fires to destroy property and kill our neighbors.	Avista included both an upgrade to Kettle Falls and a new biomass resource option in the IRP. The KF upgrade was selected in the PRS, a new facility was not cost effective in the PRS but will be continued to be modelled as an option.

# Avista's Integrate Resource Plan Public Meeting

## February 24, 2021

These are results of the poll questions given to the audiences in both the webinar and breakout rooms sessions.

### Webinar Poll Questions

1. **What would you prioritize among the choices below, acknowledging they are all important?**
  - Environmental Issues: 32
  - A Reliable System: 75
  - Affordability: 33
2. **Which Avista system provides more energy to its customers?**
  - Natural gas: 66 (this answer is most correct)
  - Electric: 69
3. **If Avista were to offer a voluntary program to charge higher prices during 4:00 pm to 8:00 pm in exchange for lower prices in other hours would you be interested?**
  - Yes: 77
  - No: 59

### Generation and Reliability Breakout Room

1. **When Avista acquires new generation resources- where should they be located?**
  - Indifferent to where resources are located: 6
  - All of the above: 26
  - Within our local communities: 9
  - Within our service territory, but not in our local communities: 6
  - Outside the service territory (i.e. another state or Canada): 1
2. **To meet reliability needs in the next 5 years, how should Avista meet this requirement**
  - Acquire natural gas generation with a modest environmental footprint- medium cost alternative: 33
  - Acquire storage resource with low operational environmental footprint- highest cost alternative: 11
  - Utilize customer outages to stabilize the grid- lowest cost alternative: 2

### Affordability & Equity Breakout Room

1. **How much of your electric bill should go towards assisting or improving the lives of individuals and communities who are economically disadvantaged?**
  - \$0 per month: 6
  - \$5 per month: 9
  - \$10 per month: 6
  - Other: 4

**2. What does an equitable transition to clean energy mean to you?**

- Lowering their energy rates: 9
- Making their homes more energy efficient: 12
- Build clean generation resources within their community: 3
- Beautification of Avista assets: 1
- Other: 1

**Natural Gas System Planning Breakout Room**

**1. If you could no longer use natural gas, which fuel would you likely use in its place?**

- Electricity: 12
- Hydrogen: 2
- Propane: 8
- Renewable Natural Gas: 6
- Wood: 6
- Other: 3

**Environmental Breakout Room**

1. How should Avista best balance customer costs and environmental stewardship?
  - Do the minimum to meet environmental requirements and keep energy rates as low as possible: 1
  - Be a partner and leader in environmental stewardship for a mod rate increase: 5
  - Marginally exceed requirements for a small rate increase: 1
  - Make environmental improvements and reduce impacts no matter the cost: 1
2. What is the most important environmental issue for you related to Avista?
  - Reducing greenhouse gas emissions: 1
  - Minimizing air pollutants such as particulate matter, volatile organics and nitrous/sulfur dioxides: 3
  - Being stewards of the water and natural resources of the Clark Fork and Spokane Rivers: 4

**Energy Efficiency Breakout Room**

1. In exchange for slightly lower energy costs, are you are interested in the utility controlling your thermostat?
  - Never: 9
  - No more than 20 hours per year: 1
  - Yes, if I can override the request if I'm too cold or hot: 18
2. What is most important to you when you invest in energy efficiency for your home?
  - Increase comfort: 4
  - Reduce emissions: 4
  - Savings on your bill: 20

## Questions from emails, breakout sessions, and chat box

<b>Net Metering Questions</b>	<b>Avista Response</b>
<p>For those of us who have solar panels on our roofs and are producing more electricity than we use, what plans do you have to compensate us for our excess electricity?</p>	<p>Customers who participate in net metering currently receive kilowatt hour (kWh) compensation for their generation. Generation produced by customers in excess of consumption is held in a 'bank', allowing kWh credit to be used in future months as needed.</p> <p>The intent of net metering is to offset your own usage, based on this intent any remaining kilowatt hour bank is reset annually in March, according to Schedule 095 in both Washington and Idaho. There are no current plans under the net metering program to provide compensation beyond the banking provision.</p> <p>Please reference Schedule 095 in both Washington and Idaho for further details.  <a href="https://myavista.com/about-us/our-rates-and-tariffs">https://myavista.com/about-us/our-rates-and-tariffs</a></p>
<b>Electric Vehicle Questions</b>	<b>Avista Response</b>
<p>Is there provision for increasing use of plug-in vehicles_(hybrid and pure electric)?</p>	<p>Yes. Avista has a transportation electrification (TE) plan publicly available at: <a href="http://www.myavista.com/transportation">www.myavista.com/transportation</a>  This plan includes Low, Baseline and High adoption scenarios for light-duty vehicles considered in Appendix B, starting on p. 81. Given the current state of policy support, industry investments, utility support, and local geographic and demographic considerations; we expect the trajectory of adoption to track between the medium and high scenarios in Washington, and between the baseline and low scenarios in Idaho.</p>
<p>What would it take to add incentives for charging at preferred times of the day, when other demand is less?</p>	<p>As demonstrated in the EVSE pilot and discussed in the TE Plan, Avista has shown that utility programs leveraging EVSE installations can accomplish this with participating customers. A new rate incentivizing off-peak charging may also be very effective, as demonstrated in other utility pilots and studies. Avista will continue to develop capabilities, with a goal to shift 50% or more of EV peak loads to off-peak in a cost-effective manner, by 2025.</p>
<p>How can you encourage the installation of more places to charge such vehicles, like in high use areas (central parking lots, shopping malls, park-and-ride lots)?</p>	<p>Avista will install, own and maintain a backbone of this charging infrastructure, up to 50% of the assessed market need. A variety of other programs and incentives including "make ready" investments, and a new commercial EV rate, will help encourage additional private investment. See the TE Plan, pp. 45-54.</p>
<p>To reduce company greenhouse gas emissions, is there a plan to convert Avista's vehicle fleet to electric?</p>	<p>Yes, Avista plans to electrify its fleet as it may be done reliably and cost effectively. See TE Plan pp. 72-73.</p>
<p>Has the waste from batteries from electric cars been added to the percent of emissions as a long term cost?</p>	<p>Avoided emissions resulting from light-duty EV adoption is shown in the TE plan on pages 41-42, based on Avista's generation mix. Likely emissions in the future based on effects from battery waste and other factors are very uncertain but may be incorporated in later studies and estimates as more</p>

	knowledge and certainty is gained. See TE Plan pp. 22-24 for discussion related to battery research and development, including second-use and recycling. The future state of battery technology and production will most likely differ greatly from the current state.
What does your company anticipate the impact to be from the forthcoming increase in electric vehicles and how will you prepare for that?	Avista expects a 39 aMW increase in residential load from electric vehicles by 2045. The Company prepares for changed in forecasted load through this biennial resource planning process and issue RFPs for various resources as needs arise.
<b>Policy Questions</b>	<b>Avista Response</b>
Why doesn't AVISTA push back against Washington State's population-reducing polices? What plans do you have if the population is killed by lack of heat?	<p>Avista isn't aware of any legislation that is specifically and explicitly intended to reduce population. Our engagement in public policy is first and foremost focused on the cost-effective operation of our energy system and the economic vitality of the communities we serve.</p> <p>Avista has an obligation to serve its customers electric and natural gas demands. When developing its resource plan, it determines the expected customer demand and the amount of resources and types of resources that can actually meet this target using standard utility practices. Avista plans for resources to meet a 1-in-20 standard. This means it has enough resources to meet all customer load in 19 of 20 possible extreme weather events.</p>
A bill was recently introduced in WA to eliminate natural gas in new residential and commercial buildings by 2030 and to replace gas by heat pumps. At colder temps, heat pumps stop producing heat efficiently and can cause a spike in demand. Your presentation includes natural gas. Please comment.	Avista shares your concern about eliminating natural gas as a customer choice for residential heating. Avista agrees that electric heat pumps lose their efficiency at lower temperatures and an "electrification" policy that requires customers to convert their natural gas heating systems to electric heat pumps will increase electric peak loads, among other impacts.
With commercial and industrial businesses, the main targets of efficiency efforts, will the harsh legislative regs. drive commercial and industrial businesses out of our region? Result, loss of jobs as well as revenue losses?	Avista appreciates that certain policies will impact the financial viability of businesses and shares the concern that such policies will have dislocation impacts on business and workers. Avista's energy efficiency analysis shows commercial and industrial businesses have opportunities to save energy economically while maintaining current requirements by installing more efficient technology. Avista's energy efficiency programs will assist these customers with cost effective financial incentives. Lastly, the expected energy cost savings from these programs will help customers be more competitive.
<b>Environmental</b>	<b>Avista Response</b>
How do we protect our environment from natural gas companies that use fracking and other means to obtain natural gas?	Avista purchases natural gas from the wholesale market and it is delivered through the pipeline system. Natural gas from all sources is mixed together, and gas from wells that used fracking technology makes up the majority of natural gas currently. The environmental issues associated with drilling for and producing natural gas are subject to local, state and

	<p>federal laws and regulation, which have increasingly been focused on the fracking process.</p> <p>Avista carefully manages natural gas once we receive it from pipelines. We were a founding member of the EPA's methane challenge in demonstrating our leak detection and maintenance efforts. In addition, natural gas producers are increasing efforts to reduce emissions of natural gas production and make this energy source more sustainable. See <a href="https://www.aga.org/natural-gas/clean-energy/">https://www.aga.org/natural-gas/clean-energy/</a> for more information.</p>
<p>Would Avista look at modern nuclear technology to create a carbon free source of power, electricity?</p> <p>What about Gen IV Nuclear? Is there any movement toward building these very clean energy plants near this region?</p>	<p>Avista considers modern nuclear energy in the context of our IRP analysis to determine if any specific offerings fit our resource needs. Currently Avista finds this technology not to be cost effective. Like others, we are watching to see how new emerging nuclear technology performs and how the cost changes as the technology develops.</p>
<p>I would like to know how Avista's plans align/don't align with Inslee? In particular, the use of natural gas, which I understand Inslee wants to limit or get rid of entirely.</p>	<p>Governor Inslee's energy policy priorities generally become part of the Washington State legislative landscape. We continue to engage in legislative settings to promote clean energy solutions that are affordable and which support reliability for our customers. Regarding natural gas, a specific bill was introduced during the 2021 legislative session. While this bill has not advanced, we will continue to work with our legislators and regulators on ways to address emissions associated with natural gas.</p>
<p>What kind of environmental impact (as well as machinery and maintenance cost) is there on the act of compressing natural gas?</p>	<p>CNG is natural gas compressed by an electric or gas-powered compressor to less than 1% of the original volume. While energy is needed for such compression and there are emissions associated with the compression process, the net effect of using CNG as a transportation fuel is reduced emissions. All fuel delivery systems, including CNG, include ongoing maintenance costs for machinery.</p>
<p>What is the problem with the Colstrip plant that it is my understanding, backs up the intermittent power from wind farms like the one in Pullman? Is it really that "dirty"? If the tribes don't want to run it, can't Avista lease it? Can you build a new state of the art coal plant?</p> <p>Coal presently provides over 60% of all electricity in the U.S. Our plans are super scrubbing in the U.S.!!</p>	<p>In the context of this IRP, we are focusing on the fact that Washington State law prohibits the delivery of coal-fired energy to customers after 2025. Colstrip is also subject to other state and federal environmental regulations, which continue to evolve. As one of six owners of the plant, Avista cannot independently determine Colstrip's future. We will continue to evaluate the role that Colstrip plays in meeting our customers' energy needs, and also how Colstrip's future impacts communities, including Tribes, in Montana. We rely on thermal generation from Colstrip, natural gas-fired plants, and our biomass plant in Kettle Falls, along with our significant hydro resources, to back up intermittent renewables. Consideration of this need is one of the key elements in our IRP.</p>
<p>Does Avista's goal for carbon neutrality consider methane emissions?</p>	<p>Avista's stated clean energy goal focuses on electricity. We are working to reduce emissions associated with natural gas and developing additional strategies with that in mind. Our natural gas IRP discusses the current state of these efforts, which we expect to build on and communicate further. Also included in both the natural gas and electric IRPs are</p>

	estimates for the methane emissions as part of the upstream emissions from fuel suppliers and transporters.
Could you still sell coal energy in Idaho?	Yes. Currently there are no prohibitions currently in Idaho for serving our customers with coal-fired electricity.
Are there perceived or anticipated issues with relicensing the existing dams in the network?	Avista relicensed our Clark Fork hydro project (two dams) in 1999, receiving a license from FERC for 45 years. We relicensed the Spokane River hydro project in 2009, receiving a 50-year license. While we don't have "relicensing" issues, we are implementing agreements with numerous local, state, federal and tribal partners on both river systems. These collaborative efforts imbed flexibility in what specific projects we undertake, for the benefit of our customers and the natural resources associated with these rivers. Please see <a href="https://www.myavista.com/about-us/celebrate-our-rivers">https://www.myavista.com/about-us/celebrate-our-rivers</a> for more information.
Is VOC worse than CO2?	It depends on the volatile organic compound or VOC. Methane, the primary component of natural gas, for the first 5-10 years is 100 times the greenhouse gas potential of CO2. Refrigerant gasses are much more potent greenhouse gases.
So the decrease by 2030 in Greenhouse Gas Emissions is mostly from changes away from coal?	Yes, Avista's forecasted reduction in greenhouse gas will be primarily from exiting the Colstrip Coal plant. The second largest reduction could be utilizing other resources rather than the buying power from the Lancaster Generation Station that uses natural gas.
How many other partial owners of the coal power producer are there?	We are 15% owner units 3 & 4. There is a total of 6 owners.
Rathdrum Prairie area, any coordination for solar or geothermal heat pumps. Plans to send out pamphlets, for swamp coolers, on demand water heaters, or ways to transition to higher demand.	We have a number of programs to help customers to reduce energy use. We work with developers regarding solar for residential and industrial plans in various ways. The IRP includes some of those plans. In the IRP, we look to fill resource needs by reviewing available options for new energy efficiency and demand response programs. Our energy efficiency team looks at developing programs based on the results of those plans. We are also adding another advisory group in Washington to reach out to communities for input about ways we can be most helpful to them within the next year. Some incentive programs are prescriptive, like lighting, while others are customer specific and require working with engineers to implement (usually for commercial and industrial customers). We have information on our website for programs for energy efficiency as well as placing solar on homes. There's a solar evaluation estimator tool that will provide solar potential for specific addresses in our service territory.
What effect with demolishing 4 dams on the low Snake River have on electric resources?	Avista does not purchase power from the Snake River Dams. The impact of the current proposal on Avista seems at this time to be indirect. However, its effect on communities served by the company could be significant. It could also have regional ramifications of clear interest to Avista. Gauging the precise extent and nature of the proposal's potential implications is difficult without more specific information about replacement generation and other measures (conservation, demand response, transmission upgrades) that the proposal does not yet define.

As a Washington-based company, will they be required to discontinue ownership of Colstrip based on the new laws that are under discussion (should those new laws be passed)?	Avista is required to stop delivering coal power to Washington customers in 2025 per the Clean Energy Transformation Act in 2019. The law does not require us to discontinue ownership of the plant and Avista must make future decisions about the plant in conjunction with the other owners.
I'd like to hear about the storage technology for variable renewables.	Avista includes many energy storage technologies in its resource planning as options to meet customer demand. These options include lithium-ion, pumped hydro, liquid air, hydrogen, and flow batteries. These technologies may be pursued in the future if they are an economic method of meeting our customer demand.
Does Avista have plans to address the impacts to fisheries due to the construction and operation of the hydroelectric facilities? The dams on the Spokane River are initially responsible for the complete extirpation of salmon in that basin. Avista should have some responsibility for recovering those runs and the communities that were impacted by their loss.	All of our hydro facilities, including the two dams on the Clark Fork and 6 on the Spokane River. Went through an extensive licensing process working with local tribes, state and federal agencies, and hundreds of stakeholders ranging from 5 to 7 years to work out the issues involved with the dams. Every week we work with the numerous tribes regarding the fisheries and bringing the steelhead back up to the upper regions. We do a lot of work together over those issues.
Solar produces less GHG short term. We do not know the environmental cost of solar waste from worn out panels long term.	This is outside of our required planning but think we will see this issue in upcoming plans regarding total life-cycle costs and the wastes associated with worn out solar panels.
Are there any plans to partner with Conmat for renewable natural gas plans?	There are opportunities regarding this, but none with Conmat specifically at this time.
One path to substantial GHG emissions is the deployment of EVs on a large scale, not only Avista's service fleet but also to private citizens but most of the Northwest doesn't have the EV charging infrastructure to support this market change. Is Avista working to address this because that is a massive increase electric demand?	Avista is committed to the development of EVs in our service area and its own fleet. The IRP includes this additional expected demand as part of our plans, but actual EV adoptions will depend on customer demand. Avista is committed to breaking down barriers to increase its adoption. Please see the EV section of these questions and answers for more details about Avista's EV plans.
Also, upgrades to street lights to reduce energy consumption?	Company-owned streetlights have been switched to LEDs. These 5-year implementation programs started in Washington in 2015 and Idaho in 2016.
As an Idaho customer, I am hoping that the stricter laws in Oregon and Washington do not equate to my power needs being met by a higher percentage of coal-based power. As new laws are passed, and since Avista has a plan to phase out from Colstrip, is it possible to assume that this coal-based power supplier will be closed?	Avista has no plans to increase coal generation as a percentage of Idaho's energy portfolio at this time. Avista does need to acquire new resources to replace capacity beginning in 2026; it is possible, but highly unlikely coal will be chosen to meet this need for Idaho customers. This issue will be brought up with the Idaho Public Utility Commission and they will review and approve any plans for phasing out coal power being used to serve Idaho customers with input from customers.
I'd like to hear a report on the "state of the salmon" and an acknowledgement of the successes in increasing salmon runs after hugely costly efforts.	Avista isn't directly involved with salmon recovery efforts. For a state of the salmon, refer to this federal site <a href="https://www.nwcouncil.org/reports/columbia-river-history/planningfishandwildlife">https://www.nwcouncil.org/reports/columbia-river-history/planningfishandwildlife</a> .
Could Colstrip be leased by Avista and run by the utility if the tribes don't want to do it?	Avista is a 15% owner in Colstrip Units 3 & 4, the remaining owners are other utilities and energy companies. Due to



Could a new state of the art back up plant for wind farms and solar, be built at a reasonable cost?	Washington law, coal cannot be used to serve customers after 2025 and new coal is more expensive than other technologies available to serve Idaho customers.
<b>Equity &amp; Affordability</b>	<b>Avista Response</b>
How does equity play into these decisions? Equity of what?	<p>The Clean Energy Transformation Act (CETA) directs utilities to ensure <i>“that all customers are benefitting from the transition to clean energy: Through the equitable distribution of energy and noneenergy benefits.”</i> RCW 19.405.040(8)</p> <p>“Equitable distribution” means a fair and just, but not necessarily equal, allocation intended to mitigate disparities in benefits and burdens, and based on current conditions, including existing legacy and cumulative impacts, which are informed by the assessment described in RCW 19.280.030(1)(k) from the most recent integrated resource plan.</p> <p>In accordance with the rules, Avista staff is currently forming an Equity Advisory Group that will advise the utility on equity issues including, but not limited to, vulnerable population designation, equity indicator development, data support and development and recommended approach for the utility’s compliance with WAC 480-100-610 (4)(c)(i). This advisory group will help determine the answer to the equity question concerning how Avista serves customer’s energy needs.</p>
Do you plan to raise your prices instead of using your profits to pay for these upgrades?	Avista must invest in new resources to comply with state law and to maintain a safe and reliable system. When the company invests capital in these assets, the State Commissions determine if these expenses are prudent. If they find them prudent, Avista will get recovery of these expenses, if the expense is a capital investment, the company may earn a return on these investments. The Commissions also set the profit levels that Avista can earn up to.
If WA makes you get rid of coal and gas, how will the rate payers be charged for the increased cost on new "green" energy infrastructure? Will Idaho have to pay for the "green" energy that WA and OR want? Or can you make them pay more for the increase in green that they crave and cost so much more?	The cost to comply with both Washington and Idaho laws will be reviewed by each state’s regulatory commission. It is expected the costs for state compliance will be borne by the customers within the state where additional costs are required. Both commissions specifically review rate requests to ensure that customers from their respective state are paying only their fair share.
How does equity play into these decisions? Equity of what?	Avista is forming an Equity Advisory group to ensure our most vulnerable customers are protected and benefit from the ongoing development of our electric system. This advisory group will also help shape how equity will be incorporated into future IRPs.
<b>Transmission/Distribution</b>	<b>Avista Response</b>
Does Avista have new builds/upgrades in distribution/transmission planned for the near future?	<p>Avista has a publicly available transmission plan at the following website: <a href="https://www.oasis.oati.com/avat/index.html">https://www.oasis.oati.com/avat/index.html</a>.</p> <p>Major Transmission projects planned for 2021 include:</p> <ul style="list-style-type: none"> <li>• Rebuild approximately 13-miles of 115kV Transmission between our Othello and Warden Substations.</li> </ul>

	<ul style="list-style-type: none"> <li>• Build new approximately 12-miles of 115kV Transmission between our Saddle Mountain and Othello Substations.</li> <li>• Rebuild approximately 7-miles of 115kV Transmission between Addy (BPA) and our Gifford Substation (1st Phase of 3-year project in Colville area).</li> <li>• Rebuild approximately 10-miles of 230kV Transmission between Oxbow (IPC) and our Lolo Substation (1st Phase of multi-phase project).</li> <li>• Integrate new 115kV Irvin Switching Station in the Spokane Valley.</li> <li>• Complete replacement of underground 115kV cables in downtown Spokane.</li> <li>• Replace approximately 3-miles of 115kV Transmission south of Springdale, WA.</li> <li>• Many smaller projects across the service territory for both Transmission and Distribution projects are included in the Oasis weblink above.</li> </ul>
What is Avista's plan to invest in burying power lines? Will it be part of this 20-year plan?	While this is an important discussion as a method to address tree-related distribution outages, burying distribution lines is not a component of the Resource Plan. For new construction, Avista undergrounds facilities when appropriate. Avista has no systemic plans to underground existing facilities at this time.
<b>Resource Selection</b>	<b>Avista Response</b>
Can Avista team up with other energy providers and universities to get large federal grants to develop and field test new energy storage systems?	Avista has partnered with several universities in Idaho to fund research in storage. Avista has also been a recipient of Washington State grant funding and field tested a vanadium flow battery in Pullman and is currently developing a project in the U-district of Spokane to integrate smart building designs and energy storage.
Does Avista have new 24/7 electric production builds/upgrades planned for the near future?	Avista's current resource plan does not anticipate any baseload or 24/7 facilities. Current plans include new peaking resources, renewable resources, energy storage, energy efficiency and demand response in addition to our current resource mix.
How is Avista expanding to meet these needs (Rathdrum prairie), and how will it affect the reliability and price of our utilities? How are you dealing with the increase of population_(and its need for power, natural gas, ...)?	From a power perspective, Avista must connect anyone requiring service in our service territory, so the electrical and natural gas infrastructure will be built to meet the demand as it develops.
Does demand add in the 30% plus increase in population?	Population is a key component of a utility load forecast. Avista's economist conducts a forecast of future population and energy growth within Avista's service territory as part of the load forecast. This forecast is updated each year and all electric and natural resource plans developed meet this forecast's estimate for energy needs. Higher and lower load growth
Why is solar + storage pushed in the late 2030-early 2040s timeframe?	While this technology is available today, the cost of solar plus storage compared to other alternatives, including renewable alternatives without storage, is higher priced until that time based on our current cost assumptions. In the next 10 to 15 years these technologies are expected to be more cost

	competitive. We review and update these cost components every two years in the IRP cycle.
I think outside area resources particularly should be assessed. Especially Montana. Are outside area resources being assessed? (asked multiple times)	Avista includes wind in Montana in the IRP and has found it to be a viable and cost effective resource alternative to meet customer needs. When Avista issues request for proposals by energy suppliers in the future, this will determine if this resource is the best option.
Also, the Grand Coulee Dam is not even using their full capacity, it is clean energy, and cheap. Is it being utilized?	Avista does not receive power from Grand Coulee Dam. This power is controlled by the Bonneville Power Administration (BPA) and is sold to other utilities. Avista does buy power from BPA on a day-to-day basis and may buy power from BPA on a longer-term basis in the future if it is a less costly option than from other facilities.
Forest biomass- is this on our radar? Is this a storage resource?	Yes, forest biomass is an important resource to Avista. We are looking to upgrade our Kettle Falls biomass facility in 2026 and we also analyze new biomass resources in the IRP.
How can Montana wind resources be utilized? Also consider Rathdrum Prairie as a wind resource	Avista has found Montana wind to be a cost-effective option to help meet resource needs. Although, actual wind acquisition from Montana will depend on a competitive bidding process. The Rathdrum Prairie's wind resource is not economically viable compared to other locations at this time.
Solar with storage- what is the storage with solar?	Storage with solar is a lithium-ion battery system coupled with a solar farm. The reason for colocation is due to tax credits and the sharing of interconnection costs.
Are there any limitation to transmission capacity specifically Canada or Montana?	There are always transmission constraints depending on location. Avista studies potential transmission interconnection points to test if the resource can connect or what will be required to facilitate the interconnection. More renewables will require more transmission or upgrades to existing to existing transmission resources.
Heard natural gas generators area being scrapped- please clarify if this is accurate given you have natural gas plans in your resource plan.	Avista is unsure which plants are being retired, although Avista does have plans to retire or end contracts with some of these resources it currently uses. Given current economics, we expect some construction of new and more efficient natural gas plants in the future.
Planning and deployment of storage why so late in comparison to building natural gas	Storage provides many options, but the ability to meet our peak planning requirements depends on several factors including costs and the duration of the storage device. We mainly need energy production and storage in winter peak months and could be more reliant on storage earlier, but it will need to be either lower cost or a modestly higher cost compared to longer duration capability resources such as new generation or pumped hydro storage.
Intermittent supply during peak demand times- Do you need back up these resources- are we doubling the energy production?	During operations we carry reserves to help handle variation from intermittent resources. These reserves are not necessarily doubling the generation required. For peak demand times we estimate a "peak credit" for the intermittent resource types which is a measurement of how well we can expect the resource to help us meet peak needs when they occur. Typically this is a relatively low percentage for renewables.
Electric Cars- The load forecast doesn't seem to reflect this increase	Avista forecasts future EV demand and EVs are planned for and expected. Each EV could add 5 to 10 kW of load to the system. This is similar amount of power to an electric water heater. Since the amount new EV's are unknown, Avista

	reevaluates its EV forecast each year and runs high and low EV scenarios to better understand how our plans could meet changes in that part of the load forecast.
All resources have problems and nothing is free. Nuclear is large piece of the US energy supply and the INL has DOE contract for modular nuclear. What is Avista's thought on nuclear.	Avista continues to evaluate nuclear and it is not being chosen in this plan due to high expected cost. Nuclear power also has additional risks from construction and waste disposal is an ongoing concern. Avista will continue to study nuclear in future IRPs and will update assumptions as more information about the modular nuclear systems is available.
Natural Gas- what is the source near Vancouver, Canada- what is the source of this Gas	Avista's natural gas for power production comes from Alberta. The Vancouver location referred to is likely the Sumas trading hub, where natural gas is traded between British Columbia and the I-5 corridor. Natural Gas may come from British Columbia wells, but it could go both ways.
What is a peaker?	A peaker is natural gas-fired generator that typically generates during peak load events. Its typically lower cost to construct but is often more expensive to operate. More efficient natural gas-fired generation is available, but it is more expensive to build and would need to run a higher percentage of the time to justify the higher costs.
What about nuclear and hydrogen fusion- Is the carbon footprint of nuclear construction to great?	Nuclear is evaluated, but the cost is too high to be included at this time. Avista studied hydrogen resources in its IRP, but not hydrogen fusion. Avista also evaluates the carbon footprint of all resources when it looks to add to the system for both construction and operations.
Do we have enough geothermal resources?	Avista has not identified any local options for geothermal. Southern Oregon, southern Idaho and Nevada have good options for geothermal. So far, the costs of these projects have been higher than other alternatives in our competitive bidding processes when the transmission costs to get geothermal resources to Avista are included.
Pumped storage/hydro; Is this option more of rate scheme than a resource due to pumping and generating at different times of the day? What about losses of pumping- you're not creating energy- correct	Pumped hydro can take advantage of different pricing throughout the day or week. It could also be used for meeting peak load events and provide reserves for intermittent generation. Yes, pumped hydro does not create energy. It loses approximately 20% of its energy when operating, but it provides a large amount of capacity and energy over a much longer period of time than other storage resources.
How are outages used to meet resource adequacy?	Outages would be the lowest cost alternative to meet resource adequacy but planning for outages does not make for a reliable system. There are costs involved with making a system more reliable, and we are always trying to weigh the risk and cost trade off of making the system more reliable.
BPA had to generate its hydro at 1 GW higher than its demand- is that the case for Avista	Avista holds reserves for wind, solar, and load variations. To help with this issue, Avista is joining the energy imbalance market to pool resources with other utilities to handle this variation across a larger number of utilities and reduce the needs and costs across the wider system.
<b>Microgrids</b>	<b>Avista Response</b>
What is Avista's plans for microgrids?	Avista has no immediate plans to implement microgrids on a large scale but continue to test and monitor trends and changes in microgrid technology. This summer we will energize a small pilot microgrid in cooperation with a local

	university. This microgrid pilot will inform decisions about their use in the future.
<b>Security</b>	<b>Avista Response</b>
What are your plans for hardening the electrical system against terrorists or other people capable of damaging the key very large transformer's cooling systems with high powered rifles or explosive drones or malware?	Avista has a comprehensive security program based on nationally recognized security frameworks and standards to manage cyber and physical security related risks. These standards address protecting, detecting, responding and recovering from physical and cybersecurity threats. In addition, we work with industry and government partners to ensure we are aware of emerging security risks and how best to address them.
PLEASE comment about protection from hacking which COULD shut down energy supply (such as elec.)	Avista has a comprehensive security program based on nationally recognized security frameworks and standards to manage cyber and physical security related risks. These standards address protecting, detecting, responding and recovering from physical and cybersecurity threats. In addition, we work with industry and government partners to ensure we are aware of emerging security risks and how best to address them.
<b>Natural Gas (or Renewable NG)</b>	<b>Avista Response</b>
To what extent is linepack a factor in scheduling?	The amount of gas in the natural gas distribution is a factor in scheduling as linepack provides the ability to flow the gas for the necessary demand. As more linepack is needed, more supply will be brought on to the system to meet the demand and keep the linepack at necessary levels.
What is the impact of recent pipeline project changes (on linepack/scheduling)?	The system is constantly modeled and monitored to ensure the supply is available to our firm customers when they need it.
Can natural gas systems be merged with hydrogen technology for longer terms storage?	Yes, in some systems in the US and Europe, limited volumes of pure hydrogen is being blended directly with the natural gas. These systems are being studied for wider application. In other systems, hydrogen is first combined with waste CO2 to make methane before being blended. In this application, the limits are much less restrictive and much more hydrogen can be integrated with the natural gas.
What are the percentage of RNG or Hydrogen gas you want to attain in your natural gas supply and what is the timeframe?	Avista is in the process of developing our goal and will share it soon.
Will blending hydrogen into natural gas affect, reduce the btu's?	Yes, the overall heating value of the blended gas will be somewhat less than natural gas that does not have a hydrogen blend. Regardless, the customer is charged on the amount of energy consumer and not on volume.
<b>Energy Efficiency &amp; Demand Response Questions</b>	<b>Avista Response</b>
What of Avista's plan for existing buildings to be more efficient so they don't lose or gain heat all the time?	Avista's resource plans identifies continuing energy efficiency programs. Many of these options include improving cost effective weatherization of homes. Please visit Avista's website for information on current energy efficiency rebates and programs. In addition to prescriptive offerings, commercial and industrial customers, can also access customized rebates

	through their account executive based on their unique energy needs and equipment.
I've been looking at solar as a potential option to reduce energy demands, but learned natural gas was the main usage we have and the ROI was negative. What offsets would be helpful on the Natural Gas side to replace our demand.	<p>Avista offers natural gas energy efficiency rebates such as Energy Star appliances, space and water heating. In addition, there are rebates for LED lighting and smart power strips to reduce phantom loads. More information can be found on Avista's website at <a href="https://myavista.com/energy-savings/energy-savings-advice">https://myavista.com/energy-savings/energy-savings-advice</a>.</p> <p>From a resource planning perspective, in addition to energy efficiency on the natural gas side of the business, options include hydrogen and renewable natural gas. On the electric side of the business, reducing dependence on natural gas will require long term storage solutions to store renewable energy for use at a later time when those resources are not available.</p>
How does Avista propose to deal with split incentives where the owner of a building passes heating and cooling bills to the tenants, but the tenants don't have long term incentives to benefit from capital investments in energy efficiency of the buildings and transportation systems?	This is a difficult question that Avista and other utilities continue to grapple with how to touch this hard-to-reach market. Utilities, regulators and legislators have been working on this issue, but there is no clear consensus yet on how to handle the split incentive problem.
As you say, DR has been around for many years. Why will it take until 2024 to launch these in Avista's territories?	Avista has conducted several pilot programs for Demand Response but has not pursued these programs due to their higher cost than alternative resource acquisitions. The latest analysis shows these programs may be cost effective as an option to meet Avista's capacity needs in 2026. We reevaluate the costs and benefits of Demand Response programs for each IRP and will continue to do so.
Regarding utility ability to control a homeowner's HVAC system, does that apply to given hours during a peak event? i.e., noon to 5 p.m.? Also, how would this work? For example, if the peak event is heat related, would this be a device placed on the HVAC that would allow Avista to alternate AC to a fan-mode in 15-minute intervals?	<p>The program design to control a home HVAC system was modeled to be used during peak heating and cooling times depending on the season for a two to four-hour time frame per participant. This can be done with either a temperature set back or by cycling the HVAC system. The customer impact is a two-degree offset during the requested/event period. Heating or cooling above/below the thermostat set point, ahead of the event period, (often called pre-heating or pre-cooling) was not included in the program design we evaluated.</p> <p>We modeled this program in two ways, one with temperature control and one with cycle control. Either program would be time based and would include specific parameters around when those programs would operate and how customers could opt out for a specific event.</p>
Is there a service you would recommend to evaluate the energy usage of my home, such as efficiency of heating system ducts/furnace (gas), hot water (gas), and home insulation?	For residential customers, a home energy audit is the best way to understand ways you may be able to reduce energy consumption in your home. This is a free program, however, it is currently suspended due to the pandemic.
How is Avista compensated for EE? That is, how does Avista deal with the natural conflict between selling energy and conserving it?	All costs related to energy efficiency are funded by customers through a bill adjustment called the "EE Tariff Rider". All customers contribute to these expenses based on the amount of energy they use that in turn will lower the cost for all customers. Avista's conflict of selling energy versus

	conserving energy is mitigated as long-term profits do not relate to the amount of customer sales, but rather the investments it makes to its system that are prudent investments as determined by the state regulatory commissions.
How will Avista do more to incentivize energy efficiency for middle income and low income customers? will there be rebates for homes converting to ductless heat pump systems from natural gas? or rebates for insulating window inserts?	For low income customers, Avista fully funds energy efficiency programs such as weatherization and appliance upgrades. Community Action Agencies, such as SNAP for Spokane County, income-qualifies customers and administers the programs.  For other customers, information on current energy efficiency programs can be found on Avista's website at <a href="https://myavista.com/energy-savings/energy-savings-advice">https://myavista.com/energy-savings/energy-savings-advice</a> .
Regarding EE upgrades, is that available only through rebates or is on-bill financing also an option? If so, would that be applicable to residential customers and business customers?	On Bill Repayment (OBR) is a new program Avista is implementing with a third-party lender. Avista will invoice and collect the monthly payment and remit to the lender for qualifying energy efficiency projects. This program will initially only be available to Avista's residential and small business customers in Washington State and is expected to be launched by the end of 2021. Avista is also looking at offering the OBR program to Oregon and Idaho customer in the future.
Can you explain what on-bill reimbursement is?	On bill reimbursement is when a customer chooses to have their Avista incentive payment for their qualifying energy efficiency measure credited towards their bill.
Sounds like we're doing what utilities do and just keeping up with regulation. Are we actually being proactive to lobby for EE improvement statewide, etc. in each jurisdiction or are you just reacting to state requirement?	Avista is part of multiple organizations to increase the amount of energy efficiency programs and offerings in the northwest. These include the Northwest Power and Conservation Council and the Northwest Energy Efficiency Alliance.
Many utility providers have developed effective "deemed and calculated" DR programs, such as more efficient charging of forklift batteries or switching to efficient lighting, so why can't Avista adopt some of those sooner than 2024?	Each utility plans for the most cost-effective programs for their unique system. Costs and customer needs are often different for each utility. Demand Response programs are different than Energy Efficiency Programs. Demand Response stops energy use for a period of time or shifts it, versus energy efficiency programs using less energy to get the same amount of work or process completed. Avista's first DR programs will be rate related programs to incent use in non-peak hours. Over time as more controllable load is added to the system, it is likely additional Demand Response options will be available.
Is Avista working with Energy Trust of Oregon to increase available options?	Avista partners with the Energy Trust of Oregon for its natural gas energy efficiency programs in Oregon.
Speaking of tariffs, what's happening with feed-in tariffs? Is Avista advocating for those?	Feed in tariffs guarantee a price paid for energy delivered to the utility. Currently the only program similar to this option is generation provided under PURPA (Public Utility Regulatory Policies Act). No other state regulation requires a feed in tariff at this time.
Haven't heard anything about neighborhood-scale geothermal, e.g. small thermal differential circulation pumps for neighborhood-scale heating and cooling.	Neighborhood scale geothermal is an option for reducing heating or cooling costs. Avista welcomes developers to pursue this option and it may qualify for energy rebates.
I haven't heard anything about neighborhood-scale renewable energy, such as solar gardens, Swedish-style	PACE programs are financing mechanisms implemented by local governments that allows property owners to finance energy efficiency and renewable energy improvements

neighborhood heating and cooling, and property-assessed clean energy financing (PACE).	through a property tax mechanism. Washington and Oregon have passed legislation allowing these programs, however, no counties in Avista's service area have an active PACE program. Avista is currently developing an On-Bill Repayment (OBR) program that will be available to owner occupied buildings for both residential and small business customers in Washington State by the end of 2021. Avista is also looking at possibilities to offer OBR for our Oregon and Idaho customers in the future.
Has Avista ever thought about putting timers on hot water heaters? I have one on mine and it's amazing how it keeps my energy down.	Avista has evaluated controlling water heaters and at this time found it to be non-economic compared to other options. Although Avista continues to evaluate this option and other options, so it may become cost effective in future plans.
What about AMI? Any EE benefits?	Yes, AMI energy efficiency benefits include customers reducing their usage from having access to near real time information and conservation voltage reduction on Avista's distribution system. The customer program for AMI energy efficiency has partially been implemented with the availability of near real time usage on-line. Usage alerts and notifications, as well as data analytics for "always on" usage is under development and will be made available soon. Conservation voltage reduction is currently in use in Avista's day-to-day operations.  Additional AMI benefits, including energy efficiency, can be found on Avista's website at <a href="https://www.myavista.com/about-us/smart-meters">https://www.myavista.com/about-us/smart-meters</a> .
Is Avista considering another community solar project as they once had in the past?	Avista is continuously evaluating the market and opportunities that will provide more renewable options to our customers. At this time, no additional community solar projects are planned.
When's the next energy fair?	The energy fairs have been suspended due to the pandemic, but Avista intends to continue the energy fairs in the future when it is safe for customers and employees.
<b>Reliability</b>	<b>Avista Response</b>
How will the lights stay on during a 10-day winter event when it is cold and dark with no wind or solar production?	Avista's current plans to continue to use natural gas and its hydro resources to maintain system reliability for extreme winter events until long-duration storage resources become available at an affordable cost.
What are Avista plans to move more of the power grid from reliable power sources like hydro, gas, coal and nuc, to unreliable sources like wind and solar?	Avista is adding renewable resources to its generation portfolio but will ensure reliable service by continuing to invest in capacity capable resources such as hydro and energy storage to ensure system reliability and resource adequacy.
What percentages of our power sources will be based on these unreliaables in the next 10, 15, 20 years?	Avista's current resource plan estimates 78% percent of retail sales will be served by clean energy resources., A portion of this generation will be from wind and solar, as well as hydro and biomass.
What protection should be increased, to avoid the types of problems Texas just encountered? Are different plans needed to prepare for damage from wildfires?	Avista must ensure its generating resources and natural gas supply are designed to withstand cold temperatures. Because of our climate, this has already been done. The second protection is to ensure Avista plans to add or maintain enough generation to serve customers during high load hours like extreme winter weather. The purpose of the resource plan is



	to determine the mix of resources needed to serve loads in these types of events. Avista is currently working with outside agencies and regulators to develop a wildfire plan but is well positioned to repair and replace damage to infrastructure from various causes.
Do you expect the amount of renewable energy potential here to increase substantially? If so, how do you estimate the storage needed, for times when wind or solar or hydro. is supplying less than usual?	Avista expects to add significant new renewable resources including wind and solar, as other regional utilities are also planning to do. The plan calls for at least 400 MW of additional wind and nearly 500 MW of solar over the next 24 years. The amount of storage will depend on the actual acquisition of specific resources and whether Washington will require real-time delivery of clean energy to its customer. For now, Avista's resource plan only plans to add 266 MW of storage, but if costs decline additional amounts could be added. The resource plan uses several modeling tools to determine how much energy can be relied upon for wind, solar and hydro resources.
what is the provision to back up when wind and solar are not available	Avista plans to use its hydro, biomass, and natural gas resources to meet this demand from intermittent resources. In the future energy may be stored in batteries, pumped hydro or another technology to assist in meeting this demand.
Why is the assumption so strongly held that resources are limited?	Resources are not necessarily limited, but rather limited at a particular price or cost or during periods of extreme weather events.
If you don't see the same future for WA, OR, and ID as what Texas is experiencing-why not? How will AVISTA and these states avoid the same fate? How do you expect to do the same program and expect different results?	The major difference between Avista and the Texas market is Avista plans to meet extreme cold and hot events, second Avista plans for resource adequacy. Texas does not have a regulatory requirement to ensure capacity during cold or hot weather events. Another major issue in Texas was fuel suppliers, specifically for natural gas, were not prepared and their equipment was not designed for cold weather events. In Avista's case, its natural gas supply comes from Canada whose suppliers encounter cold weather events every winter.
With the fossil fuels used to operate wind energy, the problem with disposing of them when they are obsolete, and seeing the fiasco in Texas, should wind even be a consideration?	While wind may not have the reliability benefits of some other resources, the technology can still be economic to replace energy needs in other time periods.
How will Avista keep north Idaho people warm and safe in the winters beyond 2025?	While Avista's resource plan show shortages beginning in 2026, the Company intends to address this in many ways including the issuance of a capacity RFP, possibly as early as 2021. In addition, the current IRP does not include any resource acquisition that may result from the 2020 Renewable RFP.
<b>General</b>	<b>Avista Response</b>
Is or was Bill Gates an investor in AVISTA?	Avista does not comment on individual owners of its stock.

### Comments provided in breakout sessions, email, or chat feature

<b>Rate Structure</b>
Inverted energy rates.

Hopefully people only home in the evening won't get penalized for using power at that time, but rather people fortunate enough to be home during times of lower use & lower costs could get the bonus of a lower rate.

Use-and-rate schedules are unnecessary. They are a recipe for prejudice. We have the resources to meet the needs of all people. Avista is playing games with the seriousness of human life.

### **Policy**

I wish that AVISTA would honestly not move forward with the April plan. I am sure you can resist and not comply with a bureaucratic environmental agency or with elected representatives who are in office based on computerized counting procedures that do not mirror the interest of the public which was shown by candidate signs in yards this fall.

### **Reliability**

I never want to hear from you that we're experiencing power outages because of reliance on green energy sources.

We need to use all sources of energy.

Finally, I'm certain the survey question regarding reliability is knee jerk to the situation Texas, even more than the outages due to the recent wind event.

Our grid isn't isolated, like in Texas.

I've taken a little time to review Avista's draft 2021 Integrated Resource Plan. Although Avista doesn't come out and say this will happen, it seems we should expect mid-winter rolling blackouts after 2025 when Avista's predicted demand will exceed electrical supply. Think of California with its utility-induced blackouts last summer, and the human tragedy and equipment destruction this winter caused by inadequate power planning in Texas. We don't want to fall into that kind of third-world situation here. I know we have a PUC and an Office of Energy and Mineral Resources but neither seems to be focused on this looming issue.

I have attached some poignant excerpts from the IRP for your consideration. The full IRP can be found here: <https://www.myavista.com/about-us/integrated-resource-planning>

It's not very comforting to learn that Avista is "concerned" about not having adequate power generation after 2025, and that they are "hopeful" that something will be done on the regional level, but sadly they have no concrete solution. This does not sound like a very good contingency plan to me. If the Region needs new generating capacity and novel utility coordination to meet peak winter demand, and considering how long it takes to plan, finance and build large projects, it sure seems the energy outlook is not looking good for our area. It's rather troubling that Avista has put its customers in this predicament after their failed attempt to merge with Canada-owned Hydro-One in 2018. I think Avista is putting our state at risk by relying so heavily on unrealized Regional solutions that are out of Avista's control. Avista hopes somehow the Regional players will create sufficient new generation and squeeze higher efficiencies out of a stressed and vulnerable network within the next 5 years. That seems far fetched; but if not, Avista should let us know the positive news before we all go out and buy whole house generators.

It seems part of the diminishing supply problem stems from green initiatives of neighboring states and Federal mandates forcing the elimination of reliable "thermal" generation in favor of unreliable, and thinly available "renewable" energy sources.

I see you are Chair of the Resources and Environment Committee, so hopefully you will have some ideas on how to pursue this issue. Idaho might already be behind the 8-ball because 2025 is looming mighty fast and there is hardly any clear answer to the coming power shortage, other than the obviously un-said "rolling black outs". According to Cliff Harris, our local weather guy, we are due for a really big winter, bigger than 2007-2008, due to the solar minimum, etc. So all I can suggest is maybe get the appropriate committees to ask Avista and the Governors Energy office the tough questions: how will they keep north Idaho people warm and safe in the winters beyond 2025?

I am no expert, just an ordinary retired person with questions about the future. Thank you for considering this concern.
<b>Affordability &amp; Equity</b>
I'm not interested in wind/solar construction. It has its place, but it is not 24/7, w/out expensive and environmentally destructive storage.
isn't all this a windy way of saying you're going to charge us more and just in time for the new minimum wage that has driven the cost of goods and services up to match. but wait grasshopper, no one raised the checks of the retired and disabled. only the prices went up which lowered the living standard of the most defenseless among us. so now you want to join slaughter.
ROFL "Affordability"
<b>Environmental</b>
Move to a ZERO carbon dioxide emissions format ASAP.
I'm not interested in wind/solar construction. It has its place, but it is not 24/7, w/out expensive and environmentally destructive storage
Use renewable energy to affect the mixture of natural gas and hydrogen in pipeline systems.
I am very concerned about Governor Inslee's plan for green energy.
Wood biomass is pollutive.
I don't think that cost is a factor that should limit the use of Small Modular Reactors. Wind machines are expensive too. They harm birds. They harm people. They require bare land. They are unsightly. They are not biodegradable. They are a fool's errand.
Commitment to environment is a vague statement that doesn't give any information as to what you will do or not do.
What about the waste from windmill blades and old solar panels?
The United States of America has been quite clean thus far; we do not need to become more so. We need to maintain our life. This is getting to be a matter of survival. All electricity is electricity; it would be a fool's game to tell customers they are getting their electricity from wind or sun and not from hydroelectric dams. That is all bogus marketing. Telling customers they can pay for "green" energy is a credit that is all on the books and this is not tied to reality. Any way that financiers can play with money and that customers can be billed more or less for fees or peak loads or anything else is all "make-work" schemes for billing departments, computer programs, marketing webinars like these public forum meetings, which are a ploy to lead us to think we can stop what you are already planning to implement because you are "committed." Your company has co-opted the best, most noble vocabulary and is using it to name your plans which will actually destroy the lives of people and the economy of America. A sample of your vocabulary includes "power production," "load growth," "lens," "focus," "committed."
The shut down of the Colstrip plant in Montana is a real sore point with many in our circles. "Storable" consistent coal still accounts for over 60% of all the power generated in the U.S., and to pretend that intermittent wind and solar can in the near term (let alone ever??) replace coal without natural gas, nuclear and hydro expansions, is irritating to many of us. The tribal influence of less than 10,000 members in our region, over the welfare of millions of U.S. citizens, is of great concern to us. I had put in some questions about Colstrip that I hope get publicly answered. Is the power generated by U.S. plants like Colstrip really that "dirty"? (U.S. companies are leaders in scrubbing pollutants out of exhausts.) Is the public being sold a false narrative in that regard, due to political pressures? Could that plant be leased by Avista and run by the utility if the tribes don't want to do it? Could a new state of the art back up plant for wind farms and solar, be built at a reasonable cost?
<b>Resource Selection</b>
Liquid Metal Batteries, Pumped Hydro, Solar incentives, net metering buy backs over used power
CANCEL ALL PLANS FOR ADDITIONAL WIND TURBINES, I am totally against the removal of the J C Boyle Dam, Copco Dams 1 & 2, and Irongate Dam, I also support solar power, but within limits. I support properly designed nuclear power. And I support Avista's natural gas projects.
Avista clearly does not want to discuss "nuclear options". I keep hoping that the miserable and complex failure of WHOOPS won't sour this region forever on that possibility.

<p>Since you have already seen the evidence of catastrophic failure in Texas, how does that not put you in legal jeopardy for future failures in WA, ID, and OR? Wind is a joke. There can be no wind. The turbines can freeze. The blades are made of fiberglass. They are so big, they must be brought in one per truck. Fossil fuels are needed to transport them. They are not biodegradable. Just like China, we need to forestall any changes from our present energy forms until we have more technologically advanced forms of energy. Wind and sun are NOT advanced forms. Our present federal-level administration is not legitimately elected. We are fools to limit ourselves to obeying their suicidal goals. We need to think other than wind and solar. It is primitive. Your questions are lose-lose. The multiple choices offered are not innovative and are not evidencing out-of-the box thinking.</p>
<p><b>General</b></p>
<p>Avista should look into internet and television and other services by using the resources that are already in place for remote area within the Avista service area</p>
<p>Choosing among affordability, environmental responsibility and reliability is a false choice. These need to be balanced, as you say.</p>
<p>Why is the assumption so strongly held that resources are limited? If we (mankind) are able to use the powers of the mind to make new discoveries of the physical world around us, why don't we get out of this doomsday outlook which says we are limited to the energy platform we are already on? We ought to be spending our time and strength building on the steps we have already taken to be able to land on the Moon and voyage to Mars, in order to get new forms of energy available to us. Specifically, environmentalists have blocked nuclear power energy. However, NuScale's Small Modular Reactors are as clean as wind, solar, and are cleaner than any fossil fuel. I think AVISTA ought to push back against Washington State's population-reducing policies. Our country was founded to promote the General Welfare of all the people, but Washington State, Oregon, and California's governors and Democratic Party controlled legislatures are horrifically proving they care nothing for the general public.</p>
<p>60% of my electric bill is how much money I already spend on gas. Ride sharing and mass transit is the answer.</p>
<p>I'm concerned about safety and shocked at the answers of indifference in where plants are located. I voted for away from communities.</p>
<p>When does Avista plan to stop extorting their customers then later boasting about record profits?</p>
<p>Avista overcharged customers by a total of \$43 million, according to a ruling by the Washington State Court of Appeals.</p>
<p>The Washington Utilities and Transportation Commission has directed Spokane-based Avista Corporation to refund \$8.4 million to electric and natural gas customers in Washington state.</p>
<p>The conversation is legitimizing foolish options. We are not limited the way you think we are. Please focus on scientific discovery of new ideas, like Benjamin Franklin and Thomas Edison did. We will not be able to maintain what we have because the production of these "green" "clean" energies are production-dependent on our present system.</p>
<p>More noble vocabulary being misused to promote the possibility of a Texas-type disaster: resources, reliability, clean, attentive to, responsible to the environment, generation, strategy, scalable, ensure, pre-credit, production history, resources, renewable, reduce carbon foot-print, need energy, build our needs, deliver, service territories, demand response, retiring existing resources, social cost of carbon, voluntary offering, energy efficiency, advancing technologies, lowering costs, hydrogen blending, opportunity matures, forecasted. All of this vocabulary puts a great-sounding face on plans for your reduction of perfectly good forms of energy in present use and divvying it out piece-meal to the result that the people will be diminished and in grave danger of dying off from supposedly new ideas, which are actually nothing at all beyond just sitting outside in the cold. I think "carbon-footprint" is a false boogey man that AVISTA is foolishly bowing down to and carrying the rest of the people to do the same. I think your assumptions and definitions need to be re-visited and reviewed. You are limiting yourselves, I believe.</p>
<p>Ecologists and environmentalists have a foolish and damaging overall philosophy and set of assumptions. Basically, they believe what Malthus said, namely, that the earth is not able to support a growing population. Actually, God said to be fruitful and multiply. He has made man with the ability (of his mind and powers of observation) to DISCOVER new ways to harness the natural laws and physical qualities of the earth. Please re-think your philosophy.</p>

I found the meeting very informative. Another example of how Avista is a stellar partner in our community. I was interrupted in my second breakout meeting but I still have a question; "What does your company anticipate the impact to be from the forthcoming increase in electric vehicles and how will you prepare for that?" This is probably an industry wide question with a complex answer. You don't need to answer me directly but point me to articles on the subject.

Why is wind/solar is renewable when you can't renew them; but natural gas it's not always there where natural gas is renewable as it comes from the earth



208.345.6933 • PO Box 844, Boise, ID 83702 • [www.idahoconservation.org](http://www.idahoconservation.org)

Sent Via email to: [John.Lyons@Avistacorp.com](mailto:John.Lyons@Avistacorp.com)

July 31, 2020

Mr. Lyons and the Avista IRP Team,

Thank you for the opportunity to request additional studies as part of the 2021 IRP process. Our requests below include some process improvements to the existing studies in the IRP as well as some new considerations. In each instance, our goal is to ensure the IRP leads to the least cost and least risk portfolio of supply side and demand side resources. As the complexity of the electric system increases, as the economics of resources change rapidly, and as new issues become even more acute, we encourage the Avista IRP team to lean into this process and set an example for the region for a best in class IRP process. We look forward to working with you and the rest of the Technical Advisory Committee to achieve these goals. Contact us anytime using the information below

Stay safe, stay healthy,

Ben Otto  
Idaho Conservation League  
208-345-6933 ext 12  
[botto@idahoconservation.org](mailto:botto@idahoconservation.org)

Dainee Gibson  
Idaho Conservation League  
[dgibson@idahoconservation.org](mailto:dgibson@idahoconservation.org)

## Study and Process Improvement Requests

### *Systemwide v state specific resource additions*

At the first Technical Advisory Committee meeting, Avista indicated the PRiSM model could add resources to Washington and Idaho separately or to the combined, interconnected system. We request a study of the costs and timeline necessary to replace the fossil-fueled component of the 35% of existing resources allocated to Idaho with an optimized portfolio of non-fossil resources including supply-side, demand-side, and storage resources. We request Avista compare the results of this Idaho-specific study to the results of the same analysis at the system-wide level. We also request a study that documents the costs to implement, monitor and document the state-specific addition of resources to an interconnected system dispatched to meet combined customer loads.

### *Existing resource costs*

We request Avista study a scenario that applies the Social Cost of Carbon to all resources, including those that serve Idaho, as offered in the first TAC meeting.

We request Avista study scenarios for Colstrip costs that reflect the changing ownership shares currently being considered by co-owners Puget Sound Energy, Northwestern Energy, and Talen. Further, we request a study of likelihood and scale of increases to Avista's share of common plant costs, remediation costs, and fuel supply costs, including minimum fuel supply and generation off-take, attributable to both the closure of Units 1 and 2 and the changing ownership share of Units 3 and 4.

We request a study of the accuracy of Avista wholesale natural gas price forecasting methodology by comparing forecasted prices in prior IRPs to prices Avista actually paid. We request this study include a comparison of the accuracy of consultant-supplied forecast to publicly-available forecasts covering the same time periods.

### *Storage*

Storage resources provide unique attributes that are not captured in traditional IRP modeling techniques that focus on energy and capacity needs in the hourly time scale. Storage technologies like Li-Ion batteries with fast reaction times, but only a few hours of capacity can address power quality and reliability needs within the hour. Medium term storage resources, such as Li-Ion batteries with 6 - 12 hour capacity, and pumped storage projects, can help integrate variable energy resources and address reliability needs. Longer term storage resources like hydrogen electrolysis paired with storage and repowered turbines, can address integration, reliability, and resiliency needs. By combining these storage resources with specific clean generation options, Avista can develop clean resources that meet the reliability metrics for flexibility, peaking, and renewable integration necessary to meet Avista's clean energy goals as well as CETA requirements.

To ensure a full and fair treatment of storage values we request the following:

- We request Avista model loads and generation at the sub-hourly level. We recognize Avista began pursuing sub-hourly modeling in the 2017 IRP and further refined the ADSS system in the 2019 IRP. We request Avista fully implement sub-hourly modeling for all IRP studies and processes.
- We request Avista study the optimal pairing of generation resources with storage of different technologies and lengths of supplying services. For example: pairing local solar or wind with Li-Ion 4hr, 6hr, and 12hr batteries; pairing pump hydro resources with regional solar, wind, and wholesale markets; pairing long term storage like hydrogen electrolysis and associated hydrogen storage with Avista's own resources and wholesale market generation.
- We request Avista study the emission reductions possible from pairing storage with specific clean generation options along with the Proposal presented to the TAC to apply the average emissions rate of the region for storage paired to generic wholesale market resources.

### *Distribution level modeling*

Distributed energy resources are increasing as products diversify and the economic proposition improves. To help encourage the optimal growth of DERs on the Avista system, we request a Hosting Capacity Analysis. This analysis could support a distributed energy resource interconnection map that identifies where distributed energy resources exist on the system or where the distribution system is constrained and could benefit from energy storage or specific demand responses. This Hosting Capacity Analysis would benefit the IRP's load forecasting and overall integration of distributed energy within the IRP. We recommend Avista define DERs broadly for this study to include: customer-sited generation and storage, utility-sited generation and storage at substations or other locations on the distribution grid, as well as public and private electric vehicle charging stations. We request Avista incorporate different load shapes that are indicative of customer generated power as well as the charging of electric vehicles to ensure accuracy in the load shapes for supply-side resource planning. The Smart Electric Power Alliance has an informative set of resources to help with this effort: <https://sepapower.org/knowledge/proposing-a-new-distribution-system-planning-model/>.

### *Flexibility Issues*

With the technological changes of a modern grid system, including flexibility in both supply and demand studies is essential as we look to the future of electric service areas. As shown in the pilot program with the Catalyst Building, the savings from energy efficiency and flexible building loads can be extremely beneficial for the electric grid as a whole. Similarly, the micro-transaction grid project in the Spokane University District is demonstrating the value of flexible loads and new market opportunities for customers to manage their power bills. To fully explore the value that flexibility brings to Idaho customers, we request Avista study the potential to expand similar projects in the Idaho service territory. At minimum, a study to see the perspective of customers' willingness to participate in such a pilot program could have lasting results.

### *Climate Change Impacts to Avista's System and Costs*

In the 2020 IRP, Avista describes how climate change is causing a rise in temperatures today in the service territory and, therefore, is influencing the load forecast. To further examine how the currently changing climate can impact the system and costs, we request Avista build upon this by studying the following:

- Loads - study changes to both long-term load forecast and the peak load forecast attributable to climate change. The 2020 IRP mentions a 1-degree increase in temperatures, but does not appear to describe how climate change is factored into the peak load forecast. The 2020 IRP also cites a temperature data set from 2013, which we recommend Avista update to the most currently available set.
- Hydro - study the potential changes to hydroelectric power generation that could result from climate-caused changes to precipitation type and timing. This study should document the range of impacts to power costs that result from the changes in hydroelectric power generation.
- Thermal plants - study potential changes to expected generation and production costs due to temperature changes. This study should include changes to expected generation and fuel costs as output varies with ambient temperatures



and the impacts to cooling water needs due to changes in precipitation and water temperatures. The study should document the range of impacts to power costs due to the change in expected generation output, fuel needs, and cooling water needs.

### *Beneficial electrification*

One of the most interesting long-term planning issues to address in the 2021 IRP is how increasing electrification of transportation can benefit the system and customers. Idaho currently imports 100% of our transportation fuels. Electrifying transportation can make Idahoans more energy secure and reduce costs since we pay above average fuel prices and below average electricity prices. And optimizing charging practices can deliver further benefits to all electric customers. The 2020 Transportation Electrification Plan (TEP) states that “In 2025, over 6,800 EVs are expected to provide Avista with gross revenue of \$2.1 million from EV charging. Subtracting an estimated \$0.5 million in marginal utility costs to generate and deliver this energy results in \$1.6 million in net revenue – savings which may be passed along to all utility customers in the form of decreased rate pressure.” To ensure Avista is prepared to serve Idaho’s clean transportation needs, we request:

- The load forecast includes the baseline projection of electric charging services, as forecasted in the 2020 TEP. We also request scenarios that consider higher penetration of EV, especially for commercial fleets, delivery vehicles, and public transportation.
- A study of how to optimize charging behaviors, including customer load management, and how to optimize the location of public and workplace charging stations to avoid distribution grid overload while maximizing grid flexibility and benefits to the system. For example, the TEP identified that the \$1,206 in electric system benefits per EV could “be increased by another \$463 per EV when load management shifts peak loads to off-peak.”

Hello Ben and Dainee,

Thank you for your continued participation and involvement in Avista's IRP. Here are the replies to your 2021 IRP study requests and suggestions for process improvements to ongoing studies.

### **System wide versus state specific resource additions**

- “We request a study of the costs and timeline necessary to replace the fossil-fueled component of the 35% of existing resources allocated to Idaho with an optimized portfolio of non-fossil resources including supply-side, demand-side, and storage resources.  
*Avista is developing a portfolio with all renewable/GHG emissions free resources as it did in its 2020 IRP.*
- We request Avista compare the results of this Idaho-specific study to the results of the same analysis at the system-wide level.  
*Yes, we will highlight the comparisons of the system-wide versus the Idaho-specific study in the IRP.*
- We also request a study that documents the costs to implement, monitor and document the state-specific addition of resources to an interconnected system dispatched to meet combined customer loads.  
*The cost allocation for new assets constructed to meet the Washington CETA law has not been decided by either Commission yet. An IRP does not answer this question. The 2021 IRP will attempt to evaluate the cost deltas between portfolios absent CETA mandated acquisition targets. Avista looks forward to working with both commissions and interested parties on this issue as new analyses become available.*

### **Existing resource costs**

- “We request Avista study a scenario that applies the Social Cost of Carbon to all resources, including those that serve Idaho, as offered in the first TAC meeting.”  
*Avista will conduct this study in the 2021 IRP.*
- “We request Avista study scenarios for Colstrip costs that reflect the changing ownership shares currently being considered by co-owners Puget Sound Energy, Northwestern Energy, and Talen. Further, we request a study of likelihood and scale of increases to Avista's share of common plant costs, remediation costs, and fuel supply costs, including minimum fuel supply and generation off-take, attributable to both the closure of Units 1 and 2 and the changing ownership share of Units 3 and 4.”  
*Regarding the change in ownership percentages for Units 3 and 4, there are no changes to Avista's responsibilities or modeling inputs to alter because Avista's 15 percent share of both units remains static under the Colstrip ownership agreement. Avista's financial responsibility for the plant*

*remains the same regardless of the non-Avista ownership or ownership percentages for Units 3 and 4. As in the last IRP, Avista is accounting for the shift (increase) in previously shared costs that are a result of the closure of units 1 and 2. Those costs increased, but Avista's share of those costs did not change. Avista has zero responsibility for the remediation costs associated with Units 1 and 2. The closure of those units did not end the financial responsibility of those remediation costs for the owners of those units (Puget Sound Energy and Talen). Avista's fuel contract is separate from the contracts that supplied Units 1 and 2. Avista's fuel contract and any subsequent mine remediation costs with our share of coal are already included in the prices being modeled in the 2021 IRP, consistent with past IRPs.*

- “We request a study of the accuracy of Avista wholesale natural gas price forecasting methodology by comparing forecasted prices in prior IRPs to prices Avista actually paid. We request this study include a comparison of the accuracy of consultant-supplied forecast to publicly-available forecasts covering the same time periods.

*The natural gas price forecast beyond the shorter term forward markets is always an area of concern because of the potential for volatility, timing and magnitude of outside events, much like the current pandemic we are now experiencing. It is in our own best interests to use good forecasts. Avista publishes its natural gas price forecasts in each IRP; including both consultant forecasts on an annual average basis. Actual natural gas prices are also publicly available. The consultants that we use work on a national as well as an international basis. They already perform their own internal analyses to make their forecasts as accurate as possible to maintain and grow their business. We are paying for their expertise and research into the natural gas market. Avista has not seen any evidence indicating that there are better forecasts available and we do not possess the resources to develop a comprehensive fundamentals based natural gas forecast on our own. Some forecasts, like those provided by the Energy Information Administration, supply some more details about the fundamentals they are using, but they are also more dated and do not provide the level of granularity into specific trading hubs. The consultants would not be able to remain in business if they had to give away all of their research for free. Please let us know if you have found other evidence or research indicating better forecasts.*

### **Storage**

- “We request Avista model loads and generation at the sub-hourly level. We recognize Avista began pursuing sub-hourly modeling in the 2017 IRP and further refined the ADSS system in the 2019 IRP. We request Avista fully implement sub-hourly modeling for all IRP studies and processes.”

*Sub-hourly modeling is challenging due to model solution complexity and data availability. Further, modeling all sub-hourly periods is not*

*technologically possible. Presently, modeling at one-hour granularity requires thousands of hours of computer processing time. Moving to intra-hour modeling would cause an exponential increase in solution time even if the data was available. ADSS and other modeling techniques are used to evaluate intra-hour values, and generally rely on sampling of relevant time periods. This is specifically the case with the complexity of modeling storage resources. Avista is working on this issue and is hopeful it will be available in future IRPs and will be added as an Action Item in the 2021 IRP if not completed for this plan.*

- “We request Avista study the optimal pairing of generation resources with storage of different technologies and lengths of supplying services. For example: pairing local solar or wind with Li-Ion 4hr, 6hr, and 12hr batteries; pairing pump hydro resources with regional solar, wind, and wholesale markets; pairing long term storage like hydrogen electrolysis and associated hydrogen storage with Avista’s own resources and wholesale market generation.”

*As described in the first TAC meeting and distributed to the TAC afterwards, this IRP is already including a wide variety of stand-alone storage and combined renewables plus storage options. The options being modeled include distribution scale 6-hour Lithium-ion; 4, 8 and 16-hour Lithium-ion; 4-hour Vanadium flow, 4-hour Zinc Bromide flow batteries; 16-hour 100 MW share pumped storage; and 100 MW solar photovoltaic with 200-MWh Lithium-Ion batteries. Avista is also modeling hydrogen using fuel cells or converted combustion turbines. Each of the hydrogen options will include long duration storage facilities as a backup to real-time deliveries. Avista’s IRP modeling includes the benefits from a portfolio optimization in its current process between storage and renewable resources.*

*Avista acknowledges there could be a benefit to pairing storage with renewables from a transmission perspective. Although the locational benefits of storage paired with resources may not be optimal when considering other “better” locations to locate the storage. Avista agrees with this concept and is trying to determine the best methodology to model these potential benefits, but the modeling of this concept may not be available in time for this IRP. It will be added as an Action Item if we are not able to develop the concept and include it in the 2021 IRP.*

- “We request Avista study the emission reductions possible from pairing storage with specific clean generation options along with the Proposal presented to the TAC to apply the average emissions rate of the region for storage paired to generic wholesale market resources.”

*Avista includes regional emissions for storage not connected to a facility; for paired resources, Avista does not include the emissions when using the paired resources. Although, over time as paired solar/storage resources are no longer obligated to use the paired resources storage*

*technology to satisfy tax credit requirements will likely use a combined grid/local power for optimization of the system.*

### **Distribution level modeling**

- “To help encourage the optimal growth of DERs on the Avista system, we request a Hosting Capacity Analysis. This analysis could support a distributed energy resource interconnection map that identifies where distributed energy resources exist on the system or where the distribution system is constrained and could benefit from energy storage or specific demand responses. This Hosting Capacity Analysis would benefit the IRP’s load forecasting and overall integration of distributed energy within the IRP. We recommend Avista define DERs broadly for this study to include: customer-sited generation and storage, utility-sited generation and storage at substations or other locations on the distribution grid, as well as public and private electric vehicle charging stations.”  
*Avista’s transmission and distribution departments are working on a public process for this type of planning. This process will likely be separate from the IRP process, but will provide information for the IRP. More details of this process and its findings will be shared with the TAC as they are developed.*
- “We request Avista incorporate different load shapes that are indicative of customer generated power as well as the charging of electric vehicles to ensure accuracy in the load shapes for supply-side resource planning. The Smart Electric Power Alliance has an informative set of resources to help with this effort: <https://sepapower.org/knowledge/proposing-a-new-distribution-system-planning-model/>.”  
*Avista welcomes the information, but at this time is using data collected from its local system for both solar and electric vehicles.*

### **Flexibility Issues**

- “With the technological changes of a modern grid system, including flexibility in both supply and demand studies is essential as we look to the future of electric service areas. As shown in the pilot program with the Catalyst Building, the savings from energy efficiency and flexible building loads can be extremely beneficial for the electric grid as a whole. Similarly, the micro-transaction grid project in the Spokane University District is demonstrating the value of flexible loads and new market opportunities for customers to manage their power bills. To fully explore the value that flexibility brings to Idaho customers, we request Avista study the potential to expand similar projects in the Idaho service territory. At minimum, a study to see the perspective of customers’ willingness to participate in such a pilot program could have lasting results.”  
*Avista appreciates the comment to also consider Idaho as a test bed for future projects and will take this under advisement. Avista utilizes the University of Idaho for several R&D efforts through a grant process for a total of \$270,000 to study efforts related to energy efficiency and flexible building loads. Example projects from the 2019/20 academic year include:*

*a program design for energy trading system for consumers, using infrared cameras for building controls, and gamification of energy use.*

### **Climate Change Impacts to Avista's System and Costs**

- “Loads - study changes to both long-term load forecast and the peak load forecast attributable to climate change. The 2020 IRP mentions a 1-degree increase in temperatures, but does not appear to describe how climate change is factored into the peak load forecast. The 2020 IRP also cites a temperature data set from 2013, which we recommend Avista update to the most currently available set.”

*Climate change is being included in the load forecast as a scenario, which was covered in the special TAC meeting on August 8, 2020 after we received this letter. Further, all load forecast scenario data is available on the IRP website. Please let us know if you have any additional questions or concerns that may have arisen since that presentation.*

- “Hydro - study the potential changes to hydroelectric power generation that could result from climate-caused changes to precipitation type and timing. This study should document the range of impacts to power costs that result from the changes in hydroelectric power generation.”

*We have obtained the climate adjustments developed by the Power Council and are reviewing them to determine how they might be incorporated into the 2021 IRP. More details will be presented at a future TAC meeting.*

- “Thermal plants - study potential changes to expected generation and production costs due to temperature changes. This study should include changes to expected generation and fuel costs as output varies with ambient temperatures and the impacts to cooling water needs due to changes in precipitation and water temperatures. The study should document the range of impacts to power costs due to the change in expected generation output, fuel needs, and cooling water needs.”

*Avista agrees temperature changes will impact the amount of production from its natural gas-fired facilities. This impact will be included in the climate change scenario.*

### **Beneficial electrification**

- “The load forecast includes the baseline projection of electric charging services, as forecasted in the 2020 TEP. We also request scenarios that consider higher penetration of EV, especially for commercial fleets, delivery vehicles, and public transportation.”

*Avista studied increasing EV penetration in the 2020 IRP. At this time, Avista will need to focus on other scenarios for this IRP because of the limited amount of time available for modeling.*

- “A study of how to optimize charging behaviors, including customer load management, and how to optimize the location of public and workplace charging stations to avoid distribution grid overload while maximizing grid flexibility and benefits to the system. For example, the TEP identified that the \$1,206 in electric system benefits per EV could “be increased by another \$463 per EV when load management shifts peak loads to off-peak.”

*Avista is updating its EV demand response program assumptions and this will be discussed at the September TAC meeting. Avista welcomes this discussion at the upcoming meeting to ensure it has robust assumptions for this IRP.*



August 18, 2020

**RE: Electrification Assumptions in August 6 Avista IRP Presentation**

---

Dear Mr. Gall, Mr. Pardee, Mr Lyons, and the Avista IRP team,

We appreciate the opportunity to provide comments on Avista's IRP. This comment letter focuses on considerations regarding the electrification of end uses scenario that the company is considering.

Washington state adopted greenhouse gas limits during the 2020 legislative session that direct the state to reduce total emissions by 95% compared to 1990 levels, or approximately 5 million tons of CO<sub>2</sub>e by 2050; for comparison, residential and commercial use of natural gas was responsible for approximately 7.3 million tons of CO<sub>2</sub>e emissions in 2015. In order for the state to achieve its overall limit, it is clear that this total must decline precipitously and studies indicate that electrification is likely the least cost pathway for doing so. Washington State's Deep Decarbonization Pathway Study, which was aimed at a less ambitious reduction target of 80% compared to 1990 levels, called for 85% reductions in residential gas use and 43% in commercial gas use reductions.

Evaluating electric sector impacts of this scale of reductions is important, and doing so must be informed by current and reasonable assumptions about appliance performance. Below we provide recommendations to update Avista's assumptions regarding representative heat pumps and water heaters, as well as additional considerations to properly model their impact on the company's system. In particular, we think it is reasonable to assume that over the period considered in the IRP, electric space and water heating choices will become dominated by heat pumps, especially with the salutary involvement of the company.

Washington's residential energy code already preferences heat pumps given their high efficiency, a preference that will only be strengthened as the code goes through subsequent updates along the path to 70% less energy consumption by new buildings by 2031<sup>1</sup> and as carbon is accounted for in code as it now is under WSEC 2018. Likewise, for customers that are converting from gas or another fuel source, they are likely to opt for the most cost-effective long-term option. This is already heat pumps rather than electric resistance units, and the economics of this choice will continue to improve.

*Electric Heat Pumps*

Avista suggests that end use efficiency of electric space heating at 35 degrees would be 150% (COP=1.5) and 100% at 5 degrees (COP=1). This does not accurately reflect the current state of the market. Climate Solutions reviewed the Northeast Energy Efficiency Partnership's (NEEP) [Cold Climate Air Source Heat Pump List](#). NEEP's definition of "cold climate" is any [IECC climate zone](#) of 4 or higher. Avista's service territory meets this definition, containing zones 5 and 6. NEEP's list contains nearly 8,000 air source heat pumps available on the market today from 89 manufacturers.

The average COP for the listed heaters operating at their maximum capacity at 5 degrees Fahrenheit is 2.09, and the lowest COP for the models they catalogue is 1.75 at that temperature. A number of models do indicate they would switch to backup heat at lower temperatures, but 4 out of 5 do not include a condition for switching and

---

<sup>1</sup> [RCW 19.27A.160](#)





would continue operating at the rated COP. Below is a histogram showing the distribution of various COPs within this product list.

Below we also provide the the average COP at a variety of other temperatures included in NEEP’s list. Because customers living in cold weather are most likely to acquire a heat pump calibrated to their needs, and because this technology invariably will continue to improve, we recommend that Avista change its end use efficiency assumption for space heating to at least 200% efficiency at 5 degrees,

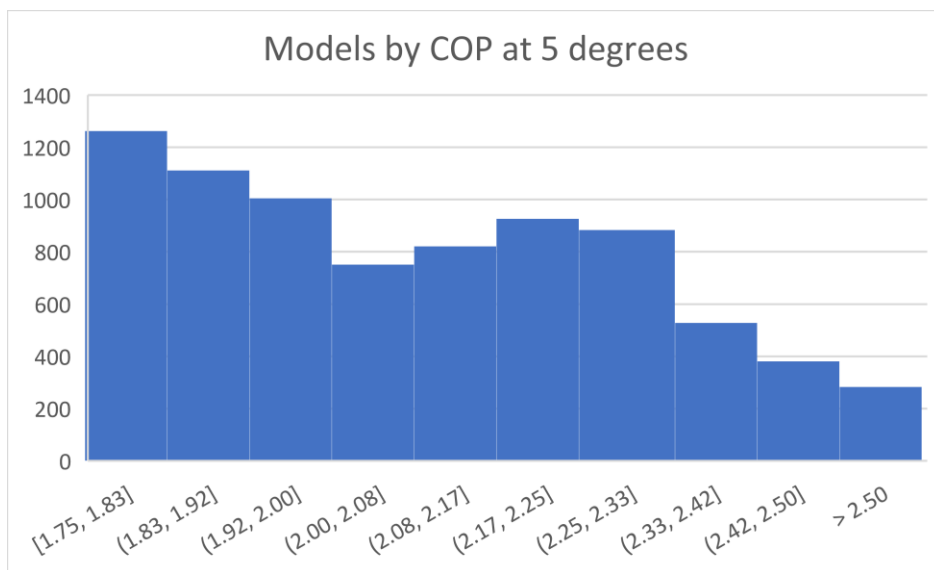

and adjust the end use efficiency statistic at 35 degrees consistent with the data provided in NEEP’s database.

Ambient Temperature (degrees Fahrenheit)	Average COP at Rated Capacity	Average COP at Max Capacity
17	2.75	2.45
47	3.81	3.58

### Water Heaters

While there are heat pump water heaters (HPWH) available that perform at the low level Avista selected for 5 degrees, we do not think selecting the bottom of the market is a prudent choice. In 2018, Energy 350 completed field tests in a variety of conditions of HPWHs in British Columbia, including at locations that lie just outside of Avista’s service territory. A summary of their results are available [here](#).

Energy 350 chose two HPWHs, one from Sanden and another from Rheem and evaluated their operation over the course of a year. The Sanden model was a split system, with a unit located outside, while the Rheem model was designed to directly replace a traditional water heater located in conditioned and semi-conditioned spaces. Their COP results bear out these differing designs. On the next page are scatter plots showing the observed performance of these systems at various temperatures, along with their lines of best fit.

From these results, and from a review of other comparable products on the market, we are concerned that the current choices Avista has made for water heater end use efficiency don’t accurately reflect operational conditions. While there are indeed HPWH that would be rated at a COP of 0.9 at 5 degrees, these are *not* designed to be placed outside and instead reside indoors—in basements, garages, or even utility closets that stay at room temperature—preventing them from needing to operate in such ambient temperature conditions. If a customer opts instead to place their water heater outside, they would select a model designed for such



conditions, along the lines of the Sanden model tested by Energy 350 whose observed COP at that temperature is 1.76. Outdoor placement of water heaters is unusual, and the Sanden split model is more expensive than the

COP vs. OAT Sanden

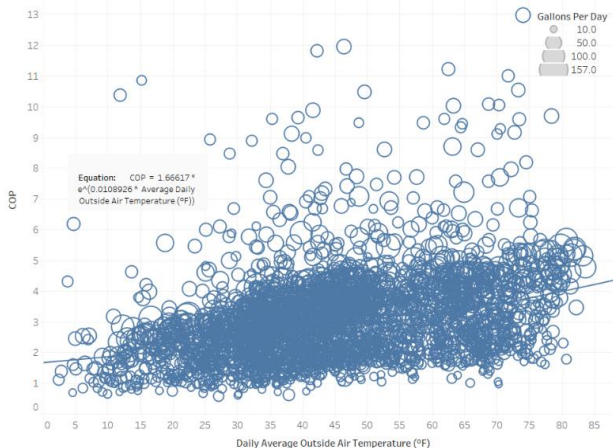

COP vs. OAT Rheem

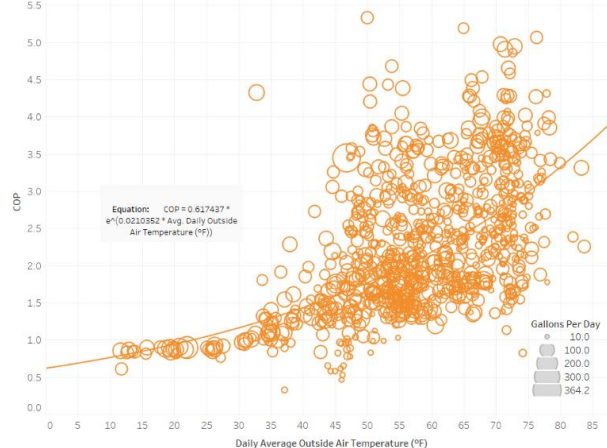

Rheem indoor option, so we would consider the proposed representative water heater the company is suggesting to be an exceedingly rare configuration on Avista's system.

For this reason, we request that Avista explain the assumptions the company is making about water heater locations, the ambient temperatures the model anticipates the water heaters will be exposed to over the course of a year, and make adjustments to more accurately reflect the product and appliance location choices customers are likely to make. At a minimum, we consider the current efficiency selected in the August 6<sup>th</sup> presentation to represent a circumstance that wouldn't occur—an indoor model placed outdoors.

Thank you for the opportunity to participate in Avista's electric Integrated Resource Plan, and for running an open and inclusive process to date. We look forward to continuing to engage with your IRP team on the resource plan and this scenario.

Sincerely,

Vlad Gutman-Britten  
Washington Director, Climate Solutions

## Gall, James

---

**From:** Gall, James  
**Sent:** Monday, September 14, 2020 10:45 AM  
**To:** Vlad Gutman  
**Cc:** Lyons, John; Pardee, Tom  
**Subject:** RE: [External] RE: Avista Draft TAC 2 Presentations for 8/6/20

Dear Mr. Gutman,

Thank you for taking the time to participate in our IRP process and provide information regarding heat pump technology. Avista encourages its customers to install heat pumps through energy efficiency education and financial incentives. Although heat pumps in our customer's climate have challenges, the technology offers savings when used with appropriate expectations.

After discussion with Avista's chief energy efficiency engineer, a few modifications to the efficiency calculation are in order. These modifications will decrease the electric load increase from home electrification. Avista is also including the workbook for this calculation on the IRP website. The modifications are as follows:

- 1) Removed the space heat effect to the efficiency of heat pump water heaters so the efficiency does not fall below 100%.
- 2) Increased space heat efficiency to include a small penetration of ductless heat pumps and to reflect how some customers shut off heat pumps to avoid the defrost cycle.
- 3) The hybrid scenario begins the load shift at 60 degrees, rather than 40 degrees, to reflect observed consumer behavior given economic inputs for fuel.

We also wanted to share our interpretation of the heat pump data you sent for both heat pumps and heat pump water heaters to clarify the whole home efficiency using the technology. Unfortunately, the COP values from vendors often do not accurately represent the actual system efficiency of heating a whole home. While the COP of the ductless units at lower temperatures are high, looking at this value alone does not consider the loss of load following ability or the 50% reduction of heating capability of the heat pump. The customer is left with a choice of either oversizing the heat pump for heating during periods of cold temperatures at a great economic first cost or by using auxiliary resistance heat to make up the load not being met by the diminished capacity of the heat pump. Also, needed items are not taken into account in the documents such as defrosting, the possibility of a reduction in efficiency due to snow and wind loads, and most homes are not entirely heated by ductless units. Our estimates are adjusted using the consumption records of the Regional Technical Forum and the regional residential building survey assessment (RBSA) which detail observed performance.

### Space Heating Conversion

Fuel conversion from natural gas to electric heating will likely be to a central heat pump instead of a ductless heat pump system because current natural gas customers already have ducted systems in their homes and usually replace their heating systems with a centralized system. This situation also applies when adding a heat pump to the natural gas furnace. The central system heat pumps are not as efficient as ductless heat pumps because the system must work in conjunction with a furnace and duct system that was not created to perfectly pair with the heat pump hardware. A home with too little return air, or return air only coming from one floor, can reduce the rated efficiency of the heat pump. With a ductless system, all of the airflow characteristics are controlled by the heat pump manufacturer resulting in a more efficient unit.

Central systems require a defrost mode when temperatures are below freezing, reducing the efficiency below 100% if the consumer does not shut this feature off. We find this occurs in 80% of homes; therefore, we assume a 90% efficiency rating at very cold temperatures when a peak load would likely occur (given this analysis assumes a 10% efficiency credit we effectively model cold temperature at 100% efficiency). Heat pump systems in our climate also experience snow coverage where the homeowner would need to physically create air space around the unit. This often does not occur during periods of inclement weather and further reduces efficiency.

Avista believes this technology will continue improving over time by utilizing similar technology as ducted systems, but due to the current limitations in these systems described above heat pumps will not achieve similar efficiencies now.

The Regional Technical Forum table shown below identifies residential single-family HVAC statistics for converting electric forced air furnaces to air source heat pumps. The savings shown for climate zones 2 and 3 show an average of 2,733 kWhrs which given the resistive load of these two climate zones represents a seasonal COP less than 1.4 for the electric heat pump. This document uses data from the residential building stock assessment. The fact that this technology works so well

in heating zone 1 makes it difficult when we would like to see those same benefits and performance used more in colder climates like ours.

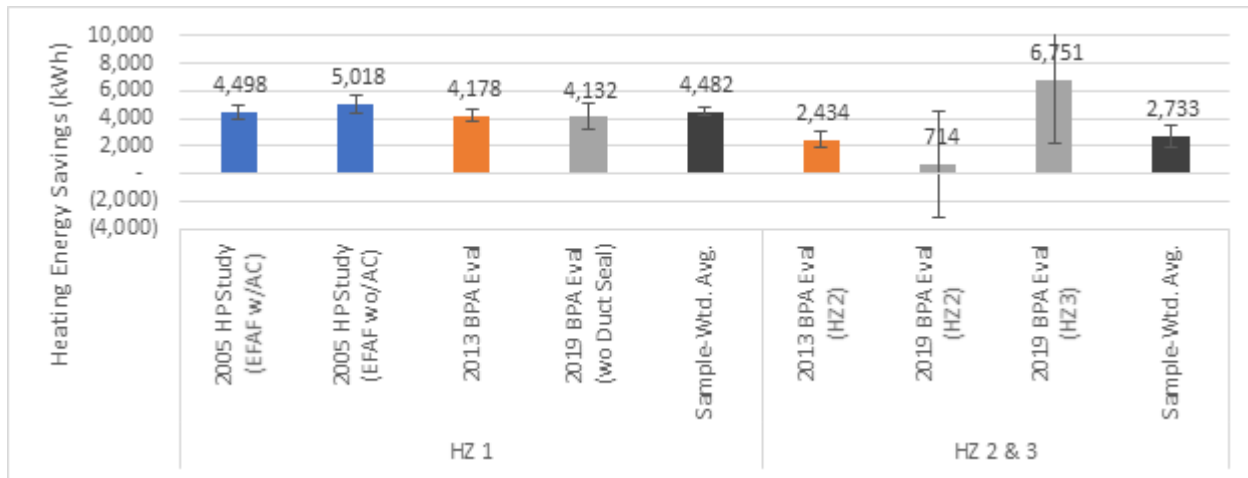

New homes that would previously include natural gas ducted systems could be ductless heat pumps in the future. This discussion continues below.

**Ductless Heat Pumps**

If a natural gas home converts to a ductless heat pump system (DHP), the whole house would not see a COP in the 3 to 5 range for homes with cold temperatures as commonly advertised by the vendors. First, the amount of BTUs produced in a ductless system significantly reduces as temperatures decline. This requires the system to run longer, contain more units, or be supplemented with additional resistance heat to maintain house temperature. Further, most homes with DHP do not use this system for the entire house and typically only heat one or two rooms while putting very low cost resistive heating in smaller rooms and areas of the house not frequently used.

Practically, in colder temperatures, it is possible to have a whole house heating COP above 1, but it is likely to be closer to 1 than 2 given the other heating requirements. Avista will revise IRP modeling to include some new homes using ductless heat pumps with slightly better than 1 COP values. The following graph from the current DHP data shows a savings in heating zones 2 and 3 of less than 920 kWhrs per unit installed. This is in homes where the average annual heating consumption is over 5,000 kWhrs. The best study here also shows other fuel influences like wood heat that can increase electric use due to the high cost of resistance electric heat after the addition of a ductless heat pump. This seasonal efficiency is less than a COP of 1.25.

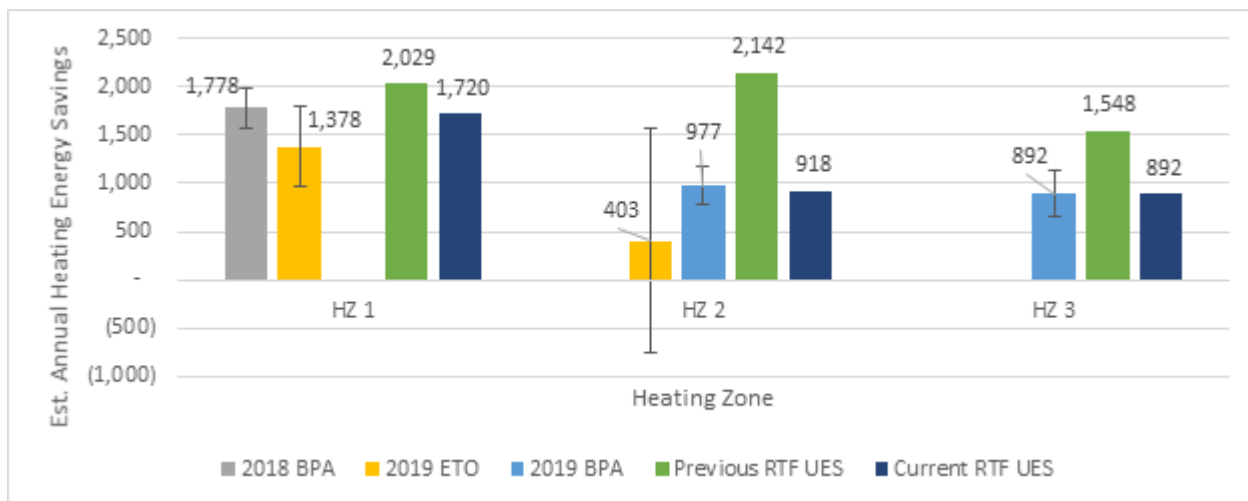

**Water Heating**

The data included on heat pump water heating is consistent with Avista’s assumptions. This data does not include the impact of the heat pump system consuming space heat from the house, when adjusting for this consumption, cold weather efficiency values are closer to 100% on a net basis. Avista’s first draft reduced these efficiencies below 100%, but has since revised them to not be below 100% as they will be in resistance mode for space heating.

Thanks again for the questions regarding this scenario it has improved the assumptions and our understanding of the complexities of electrification,

James Gall  
IRP Manager, Avista  
509-495-2189

---

**From:** Vlad Gutman <[vlad@climatesolutions.org](mailto:vlad@climatesolutions.org)>  
**Sent:** Tuesday, August 18, 2020 10:23 AM  
**To:** Gall, James <[James.Gall@avistacorp.com](mailto:James.Gall@avistacorp.com)>  
**Cc:** Lyons, John <[John.Lyons@avistacorp.com](mailto:John.Lyons@avistacorp.com)>; Pardee, Tom <[Tom.Pardee@avistacorp.com](mailto:Tom.Pardee@avistacorp.com)>  
**Subject:** RE: [External] RE: Avista Draft TAC 2 Presentations for 8/6/20

Attached please find some comments from us. In the letter, we reference a NEEP heat pump list which is available online for review (link inside). NEEP does provide it in excel form, which eases review, but they asked us not to share it for now, though I think they're checking about whether or not I can provide it to you all. In either case, you can receive the list from them directly if you become a member.

Thanks again for all your work to date, and I look forward to hearing more this afternoon.

--Vlad

---

Vlad Gutman-Britten  
Washington Director  
Climate Solutions  
206-886-4616

---

**From:** Gall, James <[James.Gall@avistacorp.com](mailto:James.Gall@avistacorp.com)>  
**Sent:** Wednesday, August 12, 2020 5:19 PM  
**To:** Vlad Gutman <[vlad@climatesolutions.org](mailto:vlad@climatesolutions.org)>  
**Cc:** Lyons, John <[John.Lyons@avistacorp.com](mailto:John.Lyons@avistacorp.com)>; Pardee, Tom <[Tom.Pardee@avistacorp.com](mailto:Tom.Pardee@avistacorp.com)>  
**Subject:** RE: [External] RE: Avista Draft TAC 2 Presentations for 8/6/20

Please send it when you can. I plan to make any modifications to the assumptions in the next two weeks prior to posting the data file. After you see the new data file we can discuss more then. This is a more straight forward scenario so it can be refined later in the process compared to other scenarios.

---

**From:** Vlad Gutman <[vlad@climatesolutions.org](mailto:vlad@climatesolutions.org)>  
**Sent:** Wednesday, August 12, 2020 4:42 PM  
**To:** Gall, James <[James.Gall@avistacorp.com](mailto:James.Gall@avistacorp.com)>  
**Cc:** Lyons, John <[John.Lyons@avistacorp.com](mailto:John.Lyons@avistacorp.com)>; Pardee, Tom <[Tom.Pardee@avistacorp.com](mailto:Tom.Pardee@avistacorp.com)>  
**Subject:** RE: [External] RE: Avista Draft TAC 2 Presentations for 8/6/20

We've collected some data on what's available on the market now, vs bleeding edge, that we intend to share with you for your consideration. I'm going to work up a letter—remind me when would be timely to have it to you by?

---

Vlad Gutman-Britten

Washington Director  
Climate Solutions  
206-886-4616

---

**From:** Gall, James <[James.Gall@avistacorp.com](mailto:James.Gall@avistacorp.com)>  
**Sent:** Wednesday, August 12, 2020 4:37 PM  
**To:** Vlad Gutman <[vlad@climatesolutions.org](mailto:vlad@climatesolutions.org)>  
**Cc:** Lyons, John <[John.Lyons@avistacorp.com](mailto:John.Lyons@avistacorp.com)>; Pardee, Tom <[Tom.Pardee@avistacorp.com](mailto:Tom.Pardee@avistacorp.com)>  
**Subject:** RE: [External] RE: Avista Draft TAC 2 Presentations for 8/6/20

Hi Vlad,

COP for heating is probably the closest definition, but not for other appliances which is why we labeled it differently. Also there are lots of options out there and we attempted to make an estimate of the average customer- not the bleeding edge of available technology. Given technology change potential, we decided to conduct a scenario with much higher efficiency ratings in the event. My hope is in the next week or two we will post the spreadsheet of our assumptions and methodology for this scenario and you can take a look.

---

**From:** Vlad Gutman <[vlad@climatesolutions.org](mailto:vlad@climatesolutions.org)>  
**Sent:** Wednesday, August 12, 2020 4:14 PM  
**To:** Lyons, John <[John.Lyons@avistacorp.com](mailto:John.Lyons@avistacorp.com)>; Gall, James <[James.Gall@avistacorp.com](mailto:James.Gall@avistacorp.com)>; Pardee, Tom <[Tom.Pardee@avistacorp.com](mailto:Tom.Pardee@avistacorp.com)>  
**Subject:** [External] RE: Avista Draft TAC 2 Presentations for 8/6/20

Hi all--

On the electrification scenario assumptions, I just want to ensure I properly understand the inputs you're using—when you say “end use efficiency”, you're referring to the COP of the appliance at that temperature. Is that correct? Not some other rating I'm not thinking of? Just want to make sure I'm properly understanding the metric.

Thanks,

Vlad

---

Vlad Gutman-Britten  
Washington Director  
Climate Solutions  
206-886-4616

---

**From:** Lyons, John <[John.Lyons@avistacorp.com](mailto:John.Lyons@avistacorp.com)>  
**Sent:** Tuesday, August 4, 2020 1:53 PM  
**To:** 'gsbooth@bpa.gov' <[gsbooth@bpa.gov](mailto:gsbooth@bpa.gov)>; 'elizabeth.hossner@pse.com' <[elizabeth.hossner@pse.com](mailto:elizabeth.hossner@pse.com)>; 'forda@mail.wsu.edu' <[forda@mail.wsu.edu](mailto:forda@mail.wsu.edu)>; Kalich, Clint <[Clint.Kalich@avistacorp.com](mailto:Clint.Kalich@avistacorp.com)>; Vermillion, Dennis <[Dennis.Vermillion@avistacorp.com](mailto:Dennis.Vermillion@avistacorp.com)>; Rahn, Greg <[Greg.Rahn@avistacorp.com](mailto:Greg.Rahn@avistacorp.com)>; Gall, James <[James.Gall@avistacorp.com](mailto:James.Gall@avistacorp.com)>; Wenke, Steve <[Steve.Wenke@avistacorp.com](mailto:Steve.Wenke@avistacorp.com)>; Lyons, John <[John.Lyons@avistacorp.com](mailto:John.Lyons@avistacorp.com)>; 'Gervais Falkner, Linda' <[IMCEAEX-O=CORP OU=Site1 cn=Recipients cn=7E2D1DA9@avistacorp.com](mailto:IMCEAEX-O=CORP OU=Site1 cn=Recipients cn=7E2D1DA9@avistacorp.com)>; Ehrbar, Pat <[Pat.Ehrbar@avistacorp.com](mailto:Pat.Ehrbar@avistacorp.com)>; McGregor, Ron <[Ron.McGregor@avistacorp.com](mailto:Ron.McGregor@avistacorp.com)>; 'SJohnson@utc.wa.gov' <[SJohnson@utc.wa.gov](mailto:SJohnson@utc.wa.gov)>; 'DReynold@utc.wa.gov' <[DReynold@utc.wa.gov](mailto:DReynold@utc.wa.gov)>; 'ChuckM@CTED.WA.GOV' <[ChuckM@CTED.WA.GOV](mailto:ChuckM@CTED.WA.GOV)>;

'dsaul@uidaho.edu' <[dsaul@uidaho.edu](mailto:dsaul@uidaho.edu)>; 'anderson.arielle@gmail.com' <[anderson.arielle@gmail.com](mailto:anderson.arielle@gmail.com)>; 'matto@McKinstry.com' <[matto@McKinstry.com](mailto:matto@McKinstry.com)>; Coelho, Renee <[Renee.Coelho@avistacorp.com](mailto:Renee.Coelho@avistacorp.com)>; Dempsey, Tom C <[Tom.Dempsey@avistacorp.com](mailto:Tom.Dempsey@avistacorp.com)>; Bryan, Todd <[todd.bryan@avistacorp.com](mailto:todd.bryan@avistacorp.com)>; 'phillip.popoff@pse.com' <[phillip.popoff@pse.com](mailto:phillip.popoff@pse.com)>; 'MStokes@idahopower.com' <[MStokes@idahopower.com](mailto:MStokes@idahopower.com)>; 'jeffmorris@energyhorizonllc.com' <[jeffmorris@energyhorizonllc.com](mailto:jeffmorris@energyhorizonllc.com)>; Ash Awad <[asha@mckinstry.com](mailto:asha@mckinstry.com)>; 'nancy@nwenergy.org' <[nancy@nwenergy.org](mailto:nancy@nwenergy.org)>; 'baz@pivotal-investments.com' <[baz@pivotal-investments.com](mailto:baz@pivotal-investments.com)>; 'dnightin@utc.wa.gov' <[dnightin@utc.wa.gov](mailto:dnightin@utc.wa.gov)>; Shane, Xin <[Xin.Shane@avistacorp.com](mailto:Xin.Shane@avistacorp.com)>; 'swalker@nrdc.org' <[swalker@nrdc.org](mailto:swalker@nrdc.org)>; 'jhuang@utc.wa.gov' <[jhuang@utc.wa.gov](mailto:jhuang@utc.wa.gov)>; Soyars, Darrell <[Darrell.Soyars@avistacorp.com](mailto:Darrell.Soyars@avistacorp.com)>; 'beverly.ikeda@pse.com' <[beverly.ikeda@pse.com](mailto:beverly.ikeda@pse.com)>; Miller, Joe <[Joe.Miller@avistacorp.com](mailto:Joe.Miller@avistacorp.com)>; 'david.wren@clearwaterpaper.com' <[david.wren@clearwaterpaper.com](mailto:david.wren@clearwaterpaper.com)>; 'Becky.King@chelanpud.org' <[Becky.King@chelanpud.org](mailto:Becky.King@chelanpud.org)>; Kimmell, Paul <[Paul.Kimmell@avistacorp.com](mailto:Paul.Kimmell@avistacorp.com)>; Lee, Lisa <[Lisa.Lee@avistacorp.com](mailto:Lisa.Lee@avistacorp.com)>; Tatko, Mike <[Mike.Tatko@avistacorp.com](mailto:Mike.Tatko@avistacorp.com)>; Trabun, Steve <[Steve.Trabun@avistacorp.com](mailto:Steve.Trabun@avistacorp.com)>; Vincent, Steve <[Steve.Vincent@avistacorp.com](mailto:Steve.Vincent@avistacorp.com)>; 'kirsten.wilson@des.wa.gov' <[kirsten.wilson@des.wa.gov](mailto:kirsten.wilson@des.wa.gov)>; 'tkhannon@comcast.net' <[tkhannon@comcast.net](mailto:tkhannon@comcast.net)>; 'Ductz@hotmail.com' <[Ductz@hotmail.com](mailto:Ductz@hotmail.com)>; 'magne.glide@comcast.net' <[magne.glide@comcast.net](mailto:magne.glide@comcast.net)>; 'Terry-schultz@comcast.net' <[Terry-schultz@comcast.net](mailto:Terry-schultz@comcast.net)>; 'bicycleward@yahoo.com' <[bicycleward@yahoo.com](mailto:bicycleward@yahoo.com)>; 'wizfe@icehouse.net' <[wizfe@icehouse.net](mailto:wizfe@icehouse.net)>; 'bregher@pacbell.net' <[bregher@pacbell.net](mailto:bregher@pacbell.net)>; 'Blittle@huntwood.com' <[Blittle@huntwood.com](mailto:Blittle@huntwood.com)>; 'colin.conway@khco.com' <[colin.conway@khco.com](mailto:colin.conway@khco.com)>; 'nskuza@ewu.edu' <[nskuza@ewu.edu](mailto:nskuza@ewu.edu)>; Forsyth, Grant <[Grant.Forsyth@avistacorp.com](mailto:Grant.Forsyth@avistacorp.com)>; Bonfield, Shawn <[Shawn.Bonfield@avistacorp.com](mailto:Shawn.Bonfield@avistacorp.com)>; 'SSimmons@NWCouncil.org' <[SSimmons@NWCouncil.org](mailto:SSimmons@NWCouncil.org)>; Steiner, Nolan <[Nolan.Steiner@avistacorp.com](mailto:Nolan.Steiner@avistacorp.com)>; 'spittman@ameresco.com' <[spittman@ameresco.com](mailto:spittman@ameresco.com)>; 'johnf@inlandpower.com' <[johnf@inlandpower.com](mailto:johnf@inlandpower.com)>; 'CMcGuire@utc.wa.gov' <[CMcGuire@utc.wa.gov](mailto:CMcGuire@utc.wa.gov)>; Maher, Patrick <[Patrick.Maher@avistacorp.com](mailto:Patrick.Maher@avistacorp.com)>; Kinney, Scott <[Scott.Kinney@avistacorp.com](mailto:Scott.Kinney@avistacorp.com)>; Thackston, Jason <[jason.thackston@avistacorp.com](mailto:jason.thackston@avistacorp.com)>; Holland, Kevin <[Kevin.Holland@avistacorp.com](mailto:Kevin.Holland@avistacorp.com)>; Rothlin, John <[John.Rothlin@avistacorp.com](mailto:John.Rothlin@avistacorp.com)>; 'Melissa.Kaplan@clearwaterpaper.com' <[Melissa.Kaplan@clearwaterpaper.com](mailto:Melissa.Kaplan@clearwaterpaper.com)>; 'Brian.Dale@clearwaterpaper.com' <[Brian.Dale@clearwaterpaper.com](mailto:Brian.Dale@clearwaterpaper.com)>; 'deank@co.whitman.wa.us' <[deank@co.whitman.wa.us](mailto:deank@co.whitman.wa.us)>; 'arts@co.whitman.wa.us' <[arts@co.whitman.wa.us](mailto:arts@co.whitman.wa.us)>; 'Lance.Henderson@directenergy.com' <[Lance.Henderson@directenergy.com](mailto:Lance.Henderson@directenergy.com)>; 'cspc@shasta.com' <[cspc@shasta.com](mailto:cspc@shasta.com)>; 'doug.howell@sierraclub.org' <[doug.howell@sierraclub.org](mailto:doug.howell@sierraclub.org)>; McClatchey, Erin <[Erin.McClatchey@avistacorp.com](mailto:Erin.McClatchey@avistacorp.com)>; 'eosborne@nwcouncil.org' <[eosborne@nwcouncil.org](mailto:eosborne@nwcouncil.org)>; 'gcharles@nwcouncil.org' <[gcharles@nwcouncil.org](mailto:gcharles@nwcouncil.org)>; 'EHiaasen@clatskaniepud.com' <[EHiaasen@clatskaniepud.com](mailto:EHiaasen@clatskaniepud.com)>; Fielder, Casey <[Casey.Fielder@avistacorp.com](mailto:Casey.Fielder@avistacorp.com)>; Kacalek, Sean <[Sean.Kacalek@avistacorp.com](mailto:Sean.Kacalek@avistacorp.com)>; Browne, Terrence <[Terrence.Browne@avistacorp.com](mailto:Terrence.Browne@avistacorp.com)>; 'merle.pedersen@perennialpower.net' <[merle.pedersen@perennialpower.net](mailto:merle.pedersen@perennialpower.net)>; Sprague, Collins <[Collins.Sprague@avistacorp.com](mailto:Collins.Sprague@avistacorp.com)>; 'bcebulko@utc.wa.gov' <[bcebulko@utc.wa.gov](mailto:bcebulko@utc.wa.gov)>; Schlect, Jeff <[jeff.schlect@avistacorp.com](mailto:jeff.schlect@avistacorp.com)>; 'joni@nwenergy.org' <[joni@nwenergy.org](mailto:joni@nwenergy.org)>; 'cconklin@spokanecity.org' <[cconklin@spokanecity.org](mailto:cconklin@spokanecity.org)>; 'botto@idahoconservation.org' <[botto@idahoconservation.org](mailto:botto@idahoconservation.org)>; 'Daniel.Howlett@energykeepersinc.com' <[Daniel.Howlett@energykeepersinc.com](mailto:Daniel.Howlett@energykeepersinc.com)>; 'Travis.Togo@energykeepersinc.com' <[Travis.Togo@energykeepersinc.com](mailto:Travis.Togo@energykeepersinc.com)>; 'doug\_krapas@iepc.com' <[doug\\_krapas@iepc.com](mailto:doug_krapas@iepc.com)>; 'kevind@iepc.com' <[kevind@iepc.com](mailto:kevind@iepc.com)>; 'honekamp@snapwa.org' <[honekamp@snapwa.org](mailto:honekamp@snapwa.org)>; Smith, Jennifer <[Jennifer.Smith@avistacorp.com](mailto:Jennifer.Smith@avistacorp.com)>; Howard, Bruce <[Bruce.Howard@avistacorp.com](mailto:Bruce.Howard@avistacorp.com)>; Magalsky, Kelly <[Kelly.Magalsky@avistacorp.com](mailto:Kelly.Magalsky@avistacorp.com)>; 'nathan.weller@Pullman-Wa.gov' <[nathan.weller@Pullman-Wa.gov](mailto:nathan.weller@Pullman-Wa.gov)>; 'simonj@gonzaga.edu' <[simonj@gonzaga.edu](mailto:simonj@gonzaga.edu)>; 'jorgenr@gmail.com' <[jorgenr@gmail.com](mailto:jorgenr@gmail.com)>; Andrea, Michael <[Michael.Andrea@avistacorp.com](mailto:Michael.Andrea@avistacorp.com)>; 'christopher.galland@ge.com' <[christopher.galland@ge.com](mailto:christopher.galland@ge.com)>; 'TJayaweera@NWCouncil.org' <[TJayaweera@NWCouncil.org](mailto:TJayaweera@NWCouncil.org)>; 'Tiffany.Floyd@deq.idaho.gov' <[Tiffany.Floyd@deq.idaho.gov](mailto:Tiffany.Floyd@deq.idaho.gov)>; 'Carl.Brown@deq.idaho.gov' <[Carl.Brown@deq.idaho.gov](mailto:Carl.Brown@deq.idaho.gov)>; 'shauna@pnucc.org' <[shauna@pnucc.org](mailto:shauna@pnucc.org)>; 'UTCenerg@utc.wa.gov' <[UTCenerg@utc.wa.gov](mailto:UTCenerg@utc.wa.gov)>; 'john.robbs@wartsila.com' <[john.robbs@wartsila.com](mailto:john.robbs@wartsila.com)>; Dillon, Mike <[Mike.Dillon@avistacorp.com](mailto:Mike.Dillon@avistacorp.com)>; 'Yao.Yin@puc.idaho.gov' <[Yao.Yin@puc.idaho.gov](mailto:Yao.Yin@puc.idaho.gov)>; Pardee, Tom <[Tom.Pardee@avistacorp.com](mailto:Tom.Pardee@avistacorp.com)>; 'UTCenerg@utc.wa.gov' <[UTCenerg@utc.wa.gov](mailto:UTCenerg@utc.wa.gov)>; 'cwright@utc.wa.gov' <[cwright@utc.wa.gov](mailto:cwright@utc.wa.gov)>; 'PDeVol@idahopower.com' <[PDeVol@idahopower.com](mailto:PDeVol@idahopower.com)>; 'dhschaub@gmail.com' <[dhschaub@gmail.com](mailto:dhschaub@gmail.com)>; Finesilver, Ryan <[Ryan.Finesilver@avistacorp.com](mailto:Ryan.Finesilver@avistacorp.com)>; 'bobby.castaneda@clearesult.com' <[bobby.castaneda@clearesult.com](mailto:bobby.castaneda@clearesult.com)>; 'brett.lichtenthaler@clearesult.com' <[brett.lichtenthaler@clearesult.com](mailto:brett.lichtenthaler@clearesult.com)>; Matt Nykiel <[mnykiel@idahoconservation.org](mailto:mnykiel@idahoconservation.org)>; 'amy@nwenergy.org' <[amy@nwenergy.org](mailto:amy@nwenergy.org)>; 'tomas@pnucc.org'

<tomas@pnucc.org>; 'bkathrens@hotmail.com' <bkathrens@hotmail.com>; 'john@waterplanet.ws' <john@waterplanet.ws>; 'esteb44@centurylink.net' <esteb44@centurylink.net>; 'Michael.Eldred@puc.idaho.gov' <Michael.Eldred@puc.idaho.gov>; 'gsnow@pera-inc.com' <gsnow@pera-inc.com>; 'jmletellier48@gmail.com' <jmletellier48@gmail.com>; Phil Jones <phil@philjonesconsulting.com>; 'CoreyD@ATG.WA.GOV' <CoreyD@ATG.WA.GOV>; 'kmaracas@comcast.net' <kmaracas@comcast.net>; Kyle Murphy <kyle@carbonwa.org>; 'bparker.work@gmail.com' <bparker.work@gmail.com>; Schuh, Karen <Karen.Schuh@avistacorp.com>; 'kathlyn.kinney@gmail.com' <kathlyn.kinney@gmail.com>; 'brian.g.henning@gmail.com' <brian.g.henning@gmail.com>; Kelly Hall <kelly.hall@climatesolutions.org>; 'david.nightingale@utc.wa.gov' <david.nightingale@utc.wa.gov>; 'Stacey.Donohue@puc.idaho.gov' <Stacey.Donohue@puc.idaho.gov>; 'Rachelle.Farnsworth@puc.idaho.gov' <Rachelle.Farnsworth@puc.idaho.gov>; 'Terri.Carlock@puc.idaho.gov' <Terri.Carlock@puc.idaho.gov>; 'tedesco@spokanetribe.com' <tedesco@spokanetribe.com>; Schultz, Kaylene <Kaylene.Schultz@avistacorp.com>; 'jennifer.snyder@utc.wa.gov' <jennifer.snyder@utc.wa.gov>; Tyrie, Mary <Mary.Tyrie@avistacorp.com>; 'John.Chatburn@oer.idaho.gov' <John.Chatburn@oer.idaho.gov>; 'eric@4sighteng.com' <eric@4sighteng.com>; Rose, Melanie <Melanie.Rose@avistacorp.com>; 'sarah.crowe@clearesult.com' <sarah.crowe@clearesult.com>; Kara Odegard 2 <kara@measurepnw.com>; 'Nathan.Sandvig@nationalgrid.com' <Nathan.Sandvig@nationalgrid.com>; 'zentzlaw@gmail.com' <zentzlaw@gmail.com>; 'jbtaylor@tesla.com' <jbtaylor@tesla.com>; 'eforbes@tesla.com' <eforbes@tesla.com>; 'zach.genta@clenera.com' <zach.genta@clenera.com>; 'fred@nwenergy.org' <fred@nwenergy.org>; 'Kevin.Keyt@puc.idaho.gov' <Kevin.Keyt@puc.idaho.gov>; 'sherber@idahoconservation.org' <sherber@idahoconservation.org>; 'chipestes@gmail.com' <chipestes@gmail.com>; Brown, Garrett <Garrett.Brown@avistacorp.com>; Ericksen, Ryan <Ryan.Ericksen@avistacorp.com>; 'Jim.Yockey@bakertilly.com' <Jim.Yockey@bakertilly.com>; 'dzentz@spokanecity.org' <dzentz@spokanecity.org>; 'emcase@heelstoneenergy.com' <emcase@heelstoneenergy.com>; 'dzentz@spokanecity.org' <dzentz@spokanecity.org>; 'lcallen@spokanecity.org' <lcallen@spokanecity.org>; 'colsen@spokanecity.org' <colsen@spokanecity.org>; 'aargetsinger@tyrenergy.com' <aargetsinger@tyrenergy.com>; 'kcalhoon@tyrenergy.com' <kcalhoon@tyrenergy.com>; 'dnh@mrwassoc.com' <dnh@mrwassoc.com>; 'glehman@stratasolar.com' <glehman@stratasolar.com>; 'Justin.Cowley@clearwaterpaper.com' <Justin.Cowley@clearwaterpaper.com>; 'richard@tollhouseenergy.com' <richard@tollhouseenergy.com>; 'jhansen@idahopower.com' <jhansen@idahopower.com>; Kimball, Paul <Paul.Kimball@avistacorp.com>; 'nikita.bankoti@utc.wa.gov' <nikita.bankoti@utc.wa.gov>; 'kate.griffith@utc.wa.gov' <kate.griffith@utc.wa.gov>; Hermanson, Lori <Lori.Hermanson@avistacorp.com>; Ghering, Amanda <amanda.ghering@avistacorp.com>; 'andresalvarez@creativerenewablesolutions.com' <andresalvarez@creativerenewablesolutions.com>; 'gerryfroese@creativerenewablesolutions.com' <gerryfroese@creativerenewablesolutions.com>; 'Peter.Sawicki@amer.mhps.com' <Peter.Sawicki@amer.mhps.com>; McDougall, James <James.McDougall@avistacorp.com>; 'boleneus@gmail.com' <boleneus@gmail.com>; Gross, John <John.Gross@avistacorp.com>; Fisher, Damon <Damon.Fisher@avistacorp.com>; Spratt, Dean <Dean.Spratt@avistacorp.com>; Vlad Gutman <vlad@climatesolutions.org>; 'dgibson@idahoconservation.org' <dgibson@idahoconservation.org>; 'DHua@NWCouncil.org' <DHua@NWCouncil.org>; 'katie@renewablenw.org' <katie@renewablenw.org>; 'mark@spokenergy.com' <mark@spokenergy.com>; 'max@renewablenw.org' <max@renewablenw.org>; 'teoacioe@comcast.net' <teoacioe@comcast.net>; 'Katie.Pegan@oer.idaho.gov' <Katie.Pegan@oer.idaho.gov>; 'Morgan.Brummund@oer.idaho.gov' <Morgan.Brummund@oer.idaho.gov>; 'gavin@northwestrenewables.com' <gavin@northwestrenewables.com>

**Subject:** Avista Draft TAC 2 Presentations for 8/6/20

Hello TAC members,

Here are the draft presentations for Thursday's joint meeting with the Natural Gas TAC and the call in information for the meeting.

Thank you,

John Lyons  
Avista Corp.



509-495-8515

---

## [Join Skype Meeting](#)

Trouble Joining? [Try Skype Web App](#)

### Join by phone

509-495-7222,,3686784# (Spokane)

English (United States)

[Find a local number](#)

Conference ID: 3686784

[Forgot your dial-in PIN?](#) | [Help](#)

---

CONFIDENTIALITY NOTICE: The contents of this email message and any attachments are intended solely for the addressee(s) and may contain confidential and/or privileged information and may be legally protected from disclosure. If you are not the intended recipient of this message or an agent of the intended recipient, or if this message has been addressed to you in error, please immediately alert the sender by reply email and then delete this message and any attachments.

---

### **USE CAUTION - EXTERNAL SENDER**

**Do not click on links or open attachments that are not familiar.**

**For questions or concerns, please e-mail [phishing@avistacorp.com](mailto:phishing@avistacorp.com)**

**Gall, James**

---

**From:** Tina Jayaweera <TJayaweera@NWCouncil.org>  
**Sent:** Friday, February 26, 2021 4:41 PM  
**To:** Lyons, John; Gall, James; Finesilver, Ryan  
**Cc:** Daniel Hua  
**Subject:** [External] RE: Avista's Draft 2021 Electric IRP  
**Attachments:** Avista 2021 Draft Electric IRP\_councilstaff.pdf

Hi Avista team,

Thanks for the opportunity to review the draft 2021 Electric IRP. Council staff appreciate the level of engagement from Avista throughout the TAC process. Attached is a copy of the IRP with embedded comments in it. Many of our comments are asking for clarification or additional detail. However, one more substantial comment from staff is on the market price forecast:

Preliminary market price forecasts for the 2021 Power Plan diverge from the pricing regime shown in this draft IRP. While understanding the underlying cause of that divergence would take a deep dive into our respective AURORA runs, given our work thus far we would expect that it's related to allowing AURORA to construct new natural gas generation outside the Northwest to replace expected retirements in the WECC thermal generation fleet (and the associated volume of those retirements).

We were given guidance from the Council and from our advisory committees to limit the potential for new natural gas generation both inside and outside the region. In doing so, we see a wave of solar and wind generation construction that depresses future market prices substantially lowering them from prices seen today. While this is largely outside of the control of the region, it presents substantial risk to regional utilities making decisions consistent with market prices that assume natural gas resources will set the marginal price.

We'd encourage all the utilities in the Northwest, including Avista, to test any IRP-based decisions against an aggressively low market price forecast. Many things are uncertain about the future of the power system in the WECC. We would not want to represent any forecast, including our own, as certain. But we do think it's a risk to consider and one that will be developing rapidly over the next few years.

While we're still working on the 2021 Power Plan, we'd be happy to share an AURORA archive file of the work done to date.

Tina Jayaweera (she/her)  
 Northwest Power & Conservation Council  
 503-222-5161

---

**From:** Lyons, John <[John.Lyons@avistacorp.com](mailto:John.Lyons@avistacorp.com)>  
**Sent:** Monday, January 4, 2021 3:20 PM  
**To:** 'gsbooth@bpa.gov' <[gsbooth@bpa.gov](mailto:gsbooth@bpa.gov)>; 'elizabeth.hossner@pse.com' <[elizabeth.hossner@pse.com](mailto:elizabeth.hossner@pse.com)>; 'forda@mail.wsu.edu' <[forda@mail.wsu.edu](mailto:forda@mail.wsu.edu)>; Kalich, Clint <[Clint.Kalich@avistacorp.com](mailto:Clint.Kalich@avistacorp.com)>; Vermillion, Dennis <[Dennis.Vermillion@avistacorp.com](mailto:Dennis.Vermillion@avistacorp.com)>; Rahn, Greg <[Greg.Rahn@avistacorp.com](mailto:Greg.Rahn@avistacorp.com)>; Gall, James <[James.Gall@avistacorp.com](mailto:James.Gall@avistacorp.com)>; Wenke, Steve <[Steve.Wenke@avistacorp.com](mailto:Steve.Wenke@avistacorp.com)>; Lyons, John <[John.Lyons@avistacorp.com](mailto:John.Lyons@avistacorp.com)>; Ehrbar, Pat <[Pat.Ehrbar@avistacorp.com](mailto:Pat.Ehrbar@avistacorp.com)>; McGregor, Ron <[Ron.McGregor@avistacorp.com](mailto:Ron.McGregor@avistacorp.com)>; 'SJohnson@utc.wa.gov' <[SJohnson@utc.wa.gov](mailto:SJohnson@utc.wa.gov)>; 'DReynold@utc.wa.gov' <[DReynold@utc.wa.gov](mailto:DReynold@utc.wa.gov)>; 'ChuckM@CTED.WA.GOV' <[ChuckM@CTED.WA.GOV](mailto:ChuckM@CTED.WA.GOV)>; 'dsaul@uidaho.edu' <[dsaul@uidaho.edu](mailto:dsaul@uidaho.edu)>; 'anderson.arielle@gmail.com' <[anderson.arielle@gmail.com](mailto:anderson.arielle@gmail.com)>; 'matto@McKinstry.com'

[matto@McKinstry.com](mailto:matto@McKinstry.com); Coelho, Renee <[Renee.Coelho@avistacorp.com](mailto:Renee.Coelho@avistacorp.com)>; Dempsey, Tom <[Tom.Dempsey@avistacorp.com](mailto:Tom.Dempsey@avistacorp.com)>; Bryan, Todd <[todd.bryan@avistacorp.com](mailto:todd.bryan@avistacorp.com)>; 'phillip.popoff@pse.com' <[phillip.popoff@pse.com](mailto:phillip.popoff@pse.com)>; 'AshA@McKinstry.com' <[AshA@McKinstry.com](mailto:AshA@McKinstry.com)>; 'nancy@nwenergy.org' <[nancy@nwenergy.org](mailto:nancy@nwenergy.org)>; 'baz@pivotal-investments.com' <[baz@pivotal-investments.com](mailto:baz@pivotal-investments.com)>; 'dnightin@utc.wa.gov' <[dnightin@utc.wa.gov](mailto:dnightin@utc.wa.gov)>; Shane, Xin <[Xin.Shane@avistacorp.com](mailto:Xin.Shane@avistacorp.com)>; 'swalker@nrdc.org' <[swalker@nrdc.org](mailto:swalker@nrdc.org)>; 'jhuang@utc.wa.gov' <[jhuang@utc.wa.gov](mailto:jhuang@utc.wa.gov)>; Soyars, Darrell <[Darrell.Soyars@avistacorp.com](mailto:Darrell.Soyars@avistacorp.com)>; 'beverly.ikeda@pse.com' <[beverly.ikeda@pse.com](mailto:beverly.ikeda@pse.com)>; Miller, Joe <[Joe.Miller@avistacorp.com](mailto:Joe.Miller@avistacorp.com)>; 'david.wren@clearwaterpaper.com' <[david.wren@clearwaterpaper.com](mailto:david.wren@clearwaterpaper.com)>; 'Becky.King@chelanpud.org' <[Becky.King@chelanpud.org](mailto:Becky.King@chelanpud.org)>; Kimmell, Paul <[Paul.Kimmell@avistacorp.com](mailto:Paul.Kimmell@avistacorp.com)>; Lee, Lisa <[Lisa.Lee@avistacorp.com](mailto:Lisa.Lee@avistacorp.com)>; Tatko, Mike <[Mike.Tatko@avistacorp.com](mailto:Mike.Tatko@avistacorp.com)>; Trabun, Steve <[Steve.Trabun@avistacorp.com](mailto:Steve.Trabun@avistacorp.com)>; Vincent, Steve <[Steve.Vincent@avistacorp.com](mailto:Steve.Vincent@avistacorp.com)>; 'kirsten.wilson@des.wa.gov' <[kirsten.wilson@des.wa.gov](mailto:kirsten.wilson@des.wa.gov)>; 'tkhannon@comcast.net' <[tkhannon@comcast.net](mailto:tkhannon@comcast.net)>; 'Ductz@hotmail.com' <[Ductz@hotmail.com](mailto:Ductz@hotmail.com)>; 'magne.glide@comcast.net' <[magne.glide@comcast.net](mailto:magne.glide@comcast.net)>; 'wizfe@icehouse.net' <[wizfe@icehouse.net](mailto:wizfe@icehouse.net)>; 'bregher@pacbell.net' <[bregher@pacbell.net](mailto:bregher@pacbell.net)>; 'Blittle@huntwood.com' <[Blittle@huntwood.com](mailto:Blittle@huntwood.com)>; 'colin.conway@khco.com' <[colin.conway@khco.com](mailto:colin.conway@khco.com)>; 'nskuza@ewu.edu' <[nskuza@ewu.edu](mailto:nskuza@ewu.edu)>; Forsyth, Grant <[Grant.Forsyth@avistacorp.com](mailto:Grant.Forsyth@avistacorp.com)>; Bonfield, Shawn <[Shawn.Bonfield@avistacorp.com](mailto:Shawn.Bonfield@avistacorp.com)>; Steven Simmons <[SSimmons@NWCouncil.org](mailto:SSimmons@NWCouncil.org)>; Steiner, Nolan <[Nolan.Steiner@avistacorp.com](mailto:Nolan.Steiner@avistacorp.com)>; 'spittman@ameresco.com' <[spittman@ameresco.com](mailto:spittman@ameresco.com)>; 'johnf@inlandpower.com' <[johnf@inlandpower.com](mailto:johnf@inlandpower.com)>; 'CMcGuire@utc.wa.gov' <[CMcGuire@utc.wa.gov](mailto:CMcGuire@utc.wa.gov)>; Maher, Patrick <[Patrick.Maher@avistacorp.com](mailto:Patrick.Maher@avistacorp.com)>; Kinney, Scott <[Scott.Kinney@avistacorp.com](mailto:Scott.Kinney@avistacorp.com)>; Thackston, Jason <[jason.thackston@avistacorp.com](mailto:jason.thackston@avistacorp.com)>; Holland, Kevin <[Kevin.Holland@avistacorp.com](mailto:Kevin.Holland@avistacorp.com)>; Rothlin, John <[John.Rothlin@avistacorp.com](mailto:John.Rothlin@avistacorp.com)>; 'Melissa.Kaplan@clearwaterpaper.com' <[Melissa.Kaplan@clearwaterpaper.com](mailto:Melissa.Kaplan@clearwaterpaper.com)>; 'Brian.Dale@clearwaterpaper.com' <[Brian.Dale@clearwaterpaper.com](mailto:Brian.Dale@clearwaterpaper.com)>; 'deank@co.whitman.wa.us' <[deank@co.whitman.wa.us](mailto:deank@co.whitman.wa.us)>; 'arts@co.whitman.wa.us' <[arts@co.whitman.wa.us](mailto:arts@co.whitman.wa.us)>; 'Lance.Henderson@directenergy.com' <[Lance.Henderson@directenergy.com](mailto:Lance.Henderson@directenergy.com)>; 'cspc@shasta.com' <[cspc@shasta.com](mailto:cspc@shasta.com)>; 'doug.howell@sierraclub.org' <[doug.howell@sierraclub.org](mailto:doug.howell@sierraclub.org)>; McClatchey, Erin <[Erin.McClatchey@avistacorp.com](mailto:Erin.McClatchey@avistacorp.com)>; Elizabeth Osborne <[EOsborne@NWCouncil.org](mailto:EOsborne@NWCouncil.org)>; Gillian Charles <[GCharles@NWCouncil.org](mailto:GCharles@NWCouncil.org)>; 'EHiaasen@clatskaniepud.com' <[EHiaasen@clatskaniepud.com](mailto:EHiaasen@clatskaniepud.com)>; Fielder, Casey <[Casey.Fielder@avistacorp.com](mailto:Casey.Fielder@avistacorp.com)>; Kacalek, Sean <[Sean.Kacalek@avistacorp.com](mailto:Sean.Kacalek@avistacorp.com)>; Browne, Terrence <[Terrence.Browne@avistacorp.com](mailto:Terrence.Browne@avistacorp.com)>; 'merle.pedersen@perennialpower.net' <[merle.pedersen@perennialpower.net](mailto:merle.pedersen@perennialpower.net)>; Sprague, Collins <[Collins.Sprague@avistacorp.com](mailto:Collins.Sprague@avistacorp.com)>; 'bcebulko@utc.wa.gov' <[bcebulko@utc.wa.gov](mailto:bcebulko@utc.wa.gov)>; Schlect, Jeff <[jeff.schlect@avistacorp.com](mailto:jeff.schlect@avistacorp.com)>; 'joni@nwenergy.org' <[joni@nwenergy.org](mailto:joni@nwenergy.org)>; 'botto@idahoconservation.org' <[botto@idahoconservation.org](mailto:botto@idahoconservation.org)>; 'Daniel.Howlett@energykeepersinc.com' <[Daniel.Howlett@energykeepersinc.com](mailto:Daniel.Howlett@energykeepersinc.com)>; 'Travis.Togo@energykeepersinc.com' <[Travis.Togo@energykeepersinc.com](mailto:Travis.Togo@energykeepersinc.com)>; 'doug\_krapas@iepc.com' <[doug\\_krapas@iepc.com](mailto:doug_krapas@iepc.com)>; 'kevind@iepc.com' <[kevind@iepc.com](mailto:kevind@iepc.com)>; 'honekamp@snapwa.org' <[honekamp@snapwa.org](mailto:honekamp@snapwa.org)>; Howard, Bruce <[Bruce.Howard@avistacorp.com](mailto:Bruce.Howard@avistacorp.com)>; Magalsky, Kelly <[Kelly.Magalsky@avistacorp.com](mailto:Kelly.Magalsky@avistacorp.com)>; 'nathan.weller@Pullman-Wa.gov' <[nathan.weller@Pullman-Wa.gov](mailto:nathan.weller@Pullman-Wa.gov)>; 'simonj@gonzaga.edu' <[simonj@gonzaga.edu](mailto:simonj@gonzaga.edu)>; 'jorgenr@gmail.com' <[jorgenr@gmail.com](mailto:jorgenr@gmail.com)>; Andrea, Michael <[Michael.Andrea@avistacorp.com](mailto:Michael.Andrea@avistacorp.com)>; 'christopher.galland@ge.com' <[christopher.galland@ge.com](mailto:christopher.galland@ge.com)>; Tina Jayaweera <[TJayaweera@NWCouncil.org](mailto:TJayaweera@NWCouncil.org)>; 'Tiffany.Floyd@deq.idaho.gov' <[Tiffany.Floyd@deq.idaho.gov](mailto:Tiffany.Floyd@deq.idaho.gov)>; 'Carl.Brown@deq.idaho.gov' <[Carl.Brown@deq.idaho.gov](mailto:Carl.Brown@deq.idaho.gov)>; 'shauna@pnucc.org' <[shauna@pnucc.org](mailto:shauna@pnucc.org)>; 'UTCenerg@utc.wa.gov' <[UTCenerg@utc.wa.gov](mailto:UTCenerg@utc.wa.gov)>; 'john.robbs@wartsila.com' <[john.robbs@wartsila.com](mailto:john.robbs@wartsila.com)>; Dillon, Mike <[Mike.Dillon@avistacorp.com](mailto:Mike.Dillon@avistacorp.com)>; 'Yao.Yin@puc.idaho.gov' <[Yao.Yin@puc.idaho.gov](mailto:Yao.Yin@puc.idaho.gov)>; Pardee, Tom <[Tom.Pardee@avistacorp.com](mailto:Tom.Pardee@avistacorp.com)>; 'UTCenerg@utc.wa.gov' <[UTCenerg@utc.wa.gov](mailto:UTCenerg@utc.wa.gov)>; 'cwright@utc.wa.gov' <[cwright@utc.wa.gov](mailto:cwright@utc.wa.gov)>; 'dhschaub@gmail.com' <[dhschaub@gmail.com](mailto:dhschaub@gmail.com)>; Finesilver, Ryan <[Ryan.Finesilver@avistacorp.com](mailto:Ryan.Finesilver@avistacorp.com)>; 'amy@nwenergy.org' <[amy@nwenergy.org](mailto:amy@nwenergy.org)>; 'tomas@pnucc.org' <[tomas@pnucc.org](mailto:tomas@pnucc.org)>; 'bkathrens@hotmail.com' <[bkathrens@hotmail.com](mailto:bkathrens@hotmail.com)>; 'esteb44@centurylink.net' <[esteb44@centurylink.net](mailto:esteb44@centurylink.net)>; 'Michael.Eldred@puc.idaho.gov' <[Michael.Eldred@puc.idaho.gov](mailto:Michael.Eldred@puc.idaho.gov)>; 'gsnow@pera-inc.com' <[gsnow@pera-inc.com](mailto:gsnow@pera-inc.com)>; 'jmletellier48@gmail.com' <[jmletellier48@gmail.com](mailto:jmletellier48@gmail.com)>; 'phil@philjonesconsulting.com' <[phil@philjonesconsulting.com](mailto:phil@philjonesconsulting.com)>; 'CoreyD@ATG.WA.GOV' <[CoreyD@ATG.WA.GOV](mailto:CoreyD@ATG.WA.GOV)>; 'kmaracas@comcast.net' <[kmaracas@comcast.net](mailto:kmaracas@comcast.net)>; 'bparker.work@gmail.com' <[bparker.work@gmail.com](mailto:bparker.work@gmail.com)>; Schuh, Karen <[Karen.Schuh@avistacorp.com](mailto:Karen.Schuh@avistacorp.com)>; 'kathlyn.kinney@gmail.com' <[kathlyn.kinney@gmail.com](mailto:kathlyn.kinney@gmail.com)>; 'brian.g.henning@gmail.com' <[brian.g.henning@gmail.com](mailto:brian.g.henning@gmail.com)>; 'kelly@climatesolutions.org'

<[kelly@climatesolutions.org](mailto:kelly@climatesolutions.org)>; 'david.nightingale@utc.wa.gov' <[david.nightingale@utc.wa.gov](mailto:david.nightingale@utc.wa.gov)>; 'Rachelle.Farnsworth@puc.idaho.gov' <[Rachelle.Farnsworth@puc.idaho.gov](mailto:Rachelle.Farnsworth@puc.idaho.gov)>; 'Terri.Carlock@puc.idaho.gov' <[Terri.Carlock@puc.idaho.gov](mailto:Terri.Carlock@puc.idaho.gov)>; 'tedesco@spokanetribe.com' <[tedesco@spokanetribe.com](mailto:tedesco@spokanetribe.com)>; Schultz, Kaylene <[Kaylene.Schultz@avistacorp.com](mailto:Kaylene.Schultz@avistacorp.com)>; 'jennifer.snyder@utc.wa.gov' <[jennifer.snyder@utc.wa.gov](mailto:jennifer.snyder@utc.wa.gov)>; Tyrie, Mary <[Mary.Tyrie@avistacorp.com](mailto:Mary.Tyrie@avistacorp.com)>; 'John.Chatburn@oer.idaho.gov' <[John.Chatburn@oer.idaho.gov](mailto:John.Chatburn@oer.idaho.gov)>; 'eric@4sighteng.com' <[eric@4sighteng.com](mailto:eric@4sighteng.com)>; Rose, Melanie <[Melanie.Rose@avistacorp.com](mailto:Melanie.Rose@avistacorp.com)>; 'kara@measurepnw.com' <[kara@measurepnw.com](mailto:kara@measurepnw.com)>; 'Nathan.Sandvig@nationalgrid.com' <[Nathan.Sandvig@nationalgrid.com](mailto:Nathan.Sandvig@nationalgrid.com)>; 'zentzlaw@gmail.com' <[zentzlaw@gmail.com](mailto:zentzlaw@gmail.com)>; 'jbtaylor@tesla.com' <[jbtaylor@tesla.com](mailto:jbtaylor@tesla.com)>; 'eforbes@tesla.com' <[eforbes@tesla.com](mailto:eforbes@tesla.com)>; 'zach.genta@clenera.com' <[zach.genta@clenera.com](mailto:zach.genta@clenera.com)>; 'fred@nwenergy.org' <[fred@nwenergy.org](mailto:fred@nwenergy.org)>; 'Kevin.Keyt@puc.idaho.gov' <[Kevin.Keyt@puc.idaho.gov](mailto:Kevin.Keyt@puc.idaho.gov)>; 'sherber@idahoconservation.org' <[sherber@idahoconservation.org](mailto:sherber@idahoconservation.org)>; 'chipestes@gmail.com' <[chipestes@gmail.com](mailto:chipestes@gmail.com)>; Brown, Garrett <[Garrett.Brown@avistacorp.com](mailto:Garrett.Brown@avistacorp.com)>; Ericksen, Ryan <[Ryan.Ericksen@avistacorp.com](mailto:Ryan.Ericksen@avistacorp.com)>; 'Jim.Yockey@bakertilly.com' <[Jim.Yockey@bakertilly.com](mailto:Jim.Yockey@bakertilly.com)>; 'dzentz@spokanecity.org' <[dzentz@spokanecity.org](mailto:dzentz@spokanecity.org)>; 'emcase@heelstoneenergy.com' <[emcase@heelstoneenergy.com](mailto:emcase@heelstoneenergy.com)>; 'dzentz@spokanecity.org' <[dzentz@spokanecity.org](mailto:dzentz@spokanecity.org)>; 'lcallen@spokanecity.org' <[lcallen@spokanecity.org](mailto:lcallen@spokanecity.org)>; 'colsen@spokanecity.org' <[colsen@spokanecity.org](mailto:colsen@spokanecity.org)>; 'aargetsinger@tyrenergy.com' <[aargetsinger@tyrenergy.com](mailto:aargetsinger@tyrenergy.com)>; 'kcalhoon@tyrenergy.com' <[kcalhoon@tyrenergy.com](mailto:kcalhoon@tyrenergy.com)>; 'dnh@mrwassoc.com' <[dnh@mrwassoc.com](mailto:dnh@mrwassoc.com)>; 'glehman@stratasolar.com' <[glehman@stratasolar.com](mailto:glehman@stratasolar.com)>; 'Justin.Cowley@clearwaterpaper.com' <[Justin.Cowley@clearwaterpaper.com](mailto:Justin.Cowley@clearwaterpaper.com)>; 'richard@tollhouseenergy.com' <[richard@tollhouseenergy.com](mailto:richard@tollhouseenergy.com)>; 'jhansen@idahopower.com' <[jhansen@idahopower.com](mailto:jhansen@idahopower.com)>; Kimball, Paul <[Paul.Kimball@avistacorp.com](mailto:Paul.Kimball@avistacorp.com)>; 'nikita.bankoti@utc.wa.gov' <[nikita.bankoti@utc.wa.gov](mailto:nikita.bankoti@utc.wa.gov)>; 'kate.griffith@utc.wa.gov' <[kate.griffith@utc.wa.gov](mailto:kate.griffith@utc.wa.gov)>; Hermanson, Lori <[Lori.Hermanson@avistacorp.com](mailto:Lori.Hermanson@avistacorp.com)>; Ghering, Amanda <[amanda.ghering@avistacorp.com](mailto:amanda.ghering@avistacorp.com)>; 'andresalvarez@creativerenewablesolutions.com' <[andresalvarez@creativerenewablesolutions.com](mailto:andresalvarez@creativerenewablesolutions.com)>; 'gerryfroese@creativerenewablesolutions.com' <[gerryfroese@creativerenewablesolutions.com](mailto:gerryfroese@creativerenewablesolutions.com)>; 'Peter.Sawicki@amer.mhps.com' <[Peter.Sawicki@amer.mhps.com](mailto:Peter.Sawicki@amer.mhps.com)>; McDougall, James <[James.McDougall@avistacorp.com](mailto:James.McDougall@avistacorp.com)>; 'boleneus@gmail.com' <[boleneus@gmail.com](mailto:boleneus@gmail.com)>; Gross, John <[John.Gross@avistacorp.com](mailto:John.Gross@avistacorp.com)>; Fisher, Damon <[Damon.Fisher@avistacorp.com](mailto:Damon.Fisher@avistacorp.com)>; Spratt, Dean <[Dean.Spratt@avistacorp.com](mailto:Dean.Spratt@avistacorp.com)>; 'vlad@climatesolutions.org' <[vlad@climatesolutions.org](mailto:vlad@climatesolutions.org)>; 'dgibson@idahoconservation.org' <[dgibson@idahoconservation.org](mailto:dgibson@idahoconservation.org)>; Daniel Hua <[DHua@NWCouncil.org](mailto:DHua@NWCouncil.org)>; 'katie@renewablenw.org' <[katie@renewablenw.org](mailto:katie@renewablenw.org)>; 'mark@spokenergy.com' <[mark@spokenergy.com](mailto:mark@spokenergy.com)>; 'max@renewablenw.org' <[max@renewablenw.org](mailto:max@renewablenw.org)>; 'teoacioe@comcast.net' <[teoacioe@comcast.net](mailto:teoacioe@comcast.net)>; 'Katie.Pegan@oer.idaho.gov' <[Katie.Pegan@oer.idaho.gov](mailto:Katie.Pegan@oer.idaho.gov)>; 'Morgan.Brummund@oer.idaho.gov' <[Morgan.Brummund@oer.idaho.gov](mailto:Morgan.Brummund@oer.idaho.gov)>; 'gavin@northwestrenewables.com' <[gavin@northwestrenewables.com](mailto:gavin@northwestrenewables.com)>; Brandon, Annette <[Annette.Brandon@avistacorp.com](mailto:Annette.Brandon@avistacorp.com)>; 'janh@biaw.com' <[janh@biaw.com](mailto:janh@biaw.com)>; 'Shay.Bauman@atg.wa.gov' <[Shay.Bauman@atg.wa.gov](mailto:Shay.Bauman@atg.wa.gov)>; 'brianfadie@gmail.com' <[brianfadie@gmail.com](mailto:brianfadie@gmail.com)>; 'mbarlow@newsunenergy.net' <[mbarlow@newsunenergy.net](mailto:mbarlow@newsunenergy.net)>; Majure, Jaime <[Jaime.Majure@avistacorp.com](mailto:Jaime.Majure@avistacorp.com)>; 'IMcGetrick@idahopower.com' <[IMcGetrick@idahopower.com](mailto:IMcGetrick@idahopower.com)>; 'SMcNeilly@idahopower.com' <[SMcNeilly@idahopower.com](mailto:SMcNeilly@idahopower.com)>; 'KFlynn@idahopower.com' <[KFlynn@idahopower.com](mailto:KFlynn@idahopower.com)>; 'Mike.Louis@puc.idaho.gov' <[Mike.Louis@puc.idaho.gov](mailto:Mike.Louis@puc.idaho.gov)>; 'Donn.English@puc.idaho.gov' <[Donn.English@puc.idaho.gov](mailto:Donn.English@puc.idaho.gov)>; 'Mike.Morrison@puc.idaho.gov' <[Mike.Morrison@puc.idaho.gov](mailto:Mike.Morrison@puc.idaho.gov)>; 'Ricky.Davis@clearwayenergy.com' <[Ricky.Davis@clearwayenergy.com](mailto:Ricky.Davis@clearwayenergy.com)>; 'ben.metcalf@galeheaddev.com' <[ben.metcalf@galeheaddev.com](mailto:ben.metcalf@galeheaddev.com)>; 'glenn.blackmon@commerce.wa.gov' <[glenn.blackmon@commerce.wa.gov](mailto:glenn.blackmon@commerce.wa.gov)>

**Subject:** Avista's Draft 2021 Electric IRP

Hello TAC Members,

Attached is a copy of the draft 2021 Electric IRP for your review. Please provide any comments or edits back to us by Monday, March 1, 2021 to me at [john.lyons@avistacorp.com](mailto:john.lyons@avistacorp.com). The final IRP and completed appendices will be filed on April 1, 2021 with the Idaho and Washington Commissions.

Our fifth and final TAC meeting will be held on Thursday, January 21, 2021. The meeting invitation and agenda will be available by the end of this week. There will also be an opportunity to provide written comments about the draft IRP to

the Washington Commission and a public meeting on February 23, 2020. We will provide more details at the fifth TAC meeting.

Thank you for all of your participation in the 2021 IRP,

John Lyons  
Avista Corp.  
509-495-8515

CONFIDENTIALITY NOTICE: The contents of this email message and any attachments are intended solely for the addressee(s) and may contain confidential and/or privileged information and may be legally protected from disclosure. If you are not the intended recipient of this message or an agent of the intended recipient, or if this message has been addressed to you in error, please immediately alert the sender by reply email and then delete this message and any attachments.

---

**USE CAUTION - EXTERNAL SENDER**

**Do not click on links or open attachments that are not familiar.**

**For questions or concerns, please e-mail [phishing@avistacorp.com](mailto:phishing@avistacorp.com)**

**Northwest Power and Conservation Council**  
**In line comments on draft Electric IRP**

Page 13: See comment in email re: suggestion to do sensitivity study with significantly lower market prices

Page 16: DR capability is for summer or winter or either?

Page 16: In section 5, the target EE is 113 aMW

Page 57: Be more clear which climate trend you are using from the Council, as we have several projected futures

Page 66: Is there any analysis of how climate change will affect hydro availability on a monthly basis?

Page 87: Also, the achievable technical potential includes a max achievability. Did the CPA use the 7P or the 2021P assumptions?

Page 88: I read this that AEG didn't use the RBSA, which is fine if Avista has sufficient res data, but it would be good to explain this. Also, since CBSA is regional, how was it downscaled to Avista. Perhaps this is in the CPA report?

Page 89: I don't understand this sentence

Page 90: How are these adjusted? Since the 2021P starts in 2022, what recent accomplishments would be incorporated?

Page 90: I think this is a bit confusing - i would recommend breaking out the "ramp rate" from the "achievability factor", since the 85- 100% is not really the ramp rate

Page 91: Incorrect units

Page 91: Typo in figure "cumulative". Also, the terminology is getting confusing here, you mean achievable \*economic\* potential, right?

Page 92: It's a little confusing that this chart goes to 2045, while the above table is through 2041. Add a sentence in paragraph above about that?

Page 93: 2022-2023, right?

Page 94: If this is utility cost, not total cost, then what assumption was made for portion of total cost made for by the utility?

Page 97: I'm not sure what this is referencing. The methodology we recommend uses 5-10 years historic and/or forward-looking, data available. What is this referencing?

Page 97: Non-energy impacts could be benefits or costs

Page 97: There is also language in the report about how these values should not be used past 2022.

Page 98: Given how Avista's generation supply is getting cleaner over the IRP time horizon, is that incorporated into this analysis?

Page 98: Has applying the 10% credit for Idaho been discussed?

Page 107: I'm confused about the numbers in this bullet compared to the bullet above that indicates the TOU opt-in has a 4.3 MW potential

Page 109: Are these costs net of anything? e.g. T&D deferrals? How are incentives treated? It would be helpful to have a brief discussion of what is included in the levelized cost calcs.

Page 109: It might be nice to have these presented in order of increasing cost?

Page 111: 8 continuous hours? That is quite long for a DR program

Page 120: How is this price determined?

Page 172: How are you incorporating other states (mostly CA) clean energy policies?

Page 179: It's not clear if/how REC prices are being incorporated

Page 193: Since renewables have zero emissions, it seems that they would be more often built in a SCC world, and thus there would be less interaction between the thermal plant and the market price.

Page 194: It is not intuitive why there would be less wind in the SCC scenario

Page 229: I think this is an overly pessimistic view of HPs. Newer units that are installed well with good controls can certainly provide a capacity benefit. I see later you explore the impact of higher efficiency units which is good. This leads me to think the Avista EE program should be focused more on ensuring installed ASHP are operating optimally

**Gall, James**

---

**From:** Gall, James  
**Sent:** Monday, March 1, 2021 12:01 PM  
**To:** Tina Jayaweera; Lyons, John; Finesilver, Ryan  
**Cc:** Daniel Hua; Kalich, Clint  
**Subject:** RE: [External] RE: Avista's Draft 2021 Electric IRP

Hi Tina and Dan,

Thank you for the review of our document. I've conducted a quick look at your comments and it appears you spend significant time in it and we will attempt to make a number of corrections and additions. I also appreciate the comments regarding the price forecast. I have concerns that prices going forward will be extremely volatile, more than Aurora can quantify, much of this volatility will depend on how much and if capacity resources will be developed or not- I also think its appropriate to understand the risk of higher and lower prices. From my work in the short term, Avista's price forecasts are too low- specifically not including risk premiums we are seeing from resource adequacy issues we are seeing. Although, in the long run there is significant downward risk with more renewables- I guess this future will depend on how far policy makers will take goals and ambitions to actual operations and construction.

There will also likely be a feedback loop as well- such as changes in loads (both industrial losses and electrification opportunities and political changes due to ramifications of policy changes) and storage opportunities. I think storage could be key in keeping prices from getting too low- but that will depend on future costs of that technology. I guess where I'm going is there is a number of paths the future may take us and its really an issue of how much time should we make to look at the region versus our portfolio.

The way things are trending I would say more focus is going toward our portfolio. In this case the real risk of having too low of forecast for prices could have an effect of less acquisition of EE, but in the end with our requirements of having clean energy and capacity- the price forecast really only impacts a solar vs wind decision- but so far wind is winning that decision due to capacity requirements and over reliance of solar elsewhere; then they question of should we build natural gas or storage- that decision is likely a matter of carbon pricing at this point. So where I'm going is and have been pondering for some time do price forecasts really matter for resource planning- given we have fewer resources to choose from and specific requirements to meet. For example, the energy price used to be a major component of our EE avoided cost- now the highest component is social cost of carbon and non-energy benefits- its seems the world has shifted from energy price forecasts.

Thanks for raising this important issue.

James

---

**From:** Tina Jayaweera <TJayaweera@NWCouncil.org>  
**Sent:** Friday, February 26, 2021 4:41 PM  
**To:** Lyons, John <John.Lyons@avistacorp.com>; Gall, James <James.Gall@avistacorp.com>; Finesilver, Ryan <Ryan.Finesilver@avistacorp.com>  
**Cc:** Daniel Hua <DHua@NWCouncil.org>  
**Subject:** [External] RE: Avista's Draft 2021 Electric IRP

Hi Avista team,



Thanks for the opportunity to review the draft 2021 Electric IRP. Council staff appreciate the level of engagement from Avista throughout the TAC process. Attached is a copy of the IRP with embedded comments in it. Many of our comments are asking for clarification or additional detail. However, one more substantial comment from staff is on the market price forecast:

Preliminary market price forecasts for the 2021 Power Plan diverge from the pricing regime shown in this draft IRP. While understanding the underlying cause of that divergence would take a deep dive into our respective AURORA runs, given our work thus far we would expect that it's related to allowing AURORA to construct new natural gas generation outside the Northwest to replace expected retirements in the WECC thermal generation fleet (and the associated volume of those retirements).

We were given guidance from the Council and from our advisory committees to limit the potential for new natural gas generation both inside and outside the region. In doing so, we see a wave of solar and wind generation construction that depresses future market prices substantially lowering them from prices seen today. While this is largely outside of the control of the region, it presents substantial risk to regional utilities making decisions consistent with market prices that assume natural gas resources will set the marginal price.

We'd encourage all the utilities in the Northwest, including Avista, to test any IRP-based decisions against an aggressively low market price forecast. Many things are uncertain about the future of the power system in the WECC. We would not want to represent any forecast, including our own, as certain. But we do think it's a risk to consider and one that will be developing rapidly over the next few years.

While we're still working on the 2021 Power Plan, we'd be happy to share an AURORA archive file of the work done to date.

Tina Jayaweera (she/her)  
Northwest Power & Conservation Council  
503-222-5161

---

**From:** Lyons, John <[John.Lyons@avistacorp.com](mailto:John.Lyons@avistacorp.com)>

**Sent:** Monday, January 4, 2021 3:20 PM

**To:** 'gsbooth@bpa.gov' <[gsbooth@bpa.gov](mailto:gsbooth@bpa.gov)>; 'elizabeth.hossner@pse.com' <[elizabeth.hossner@pse.com](mailto:elizabeth.hossner@pse.com)>; 'forda@mail.wsu.edu' <[forda@mail.wsu.edu](mailto:forda@mail.wsu.edu)>; Kalich, Clint <[Clint.Kalich@avistacorp.com](mailto:Clint.Kalich@avistacorp.com)>; Vermillion, Dennis <[Dennis.Vermillion@avistacorp.com](mailto:Dennis.Vermillion@avistacorp.com)>; Rahn, Greg <[Greg.Rahn@avistacorp.com](mailto:Greg.Rahn@avistacorp.com)>; Gall, James <[James.Gall@avistacorp.com](mailto:James.Gall@avistacorp.com)>; Wenke, Steve <[Steve.Wenke@avistacorp.com](mailto:Steve.Wenke@avistacorp.com)>; Lyons, John <[John.Lyons@avistacorp.com](mailto:John.Lyons@avistacorp.com)>; Ehrbar, Pat <[Pat.Ehrbar@avistacorp.com](mailto:Pat.Ehrbar@avistacorp.com)>; McGregor, Ron <[Ron.McGregor@avistacorp.com](mailto:Ron.McGregor@avistacorp.com)>; 'SJohnson@utc.wa.gov' <[SJohnson@utc.wa.gov](mailto:SJohnson@utc.wa.gov)>; 'DReynold@utc.wa.gov' <[DReynold@utc.wa.gov](mailto:DReynold@utc.wa.gov)>; 'ChuckM@CTED.WA.GOV' <[ChuckM@CTED.WA.GOV](mailto:ChuckM@CTED.WA.GOV)>; 'dsaul@uidaho.edu' <[dsaul@uidaho.edu](mailto:dsaul@uidaho.edu)>; 'anderson.arielle@gmail.com' <[anderson.arielle@gmail.com](mailto:anderson.arielle@gmail.com)>; 'matto@McKinstry.com' <[matto@McKinstry.com](mailto:matto@McKinstry.com)>; Coelho, Renee <[Renee.Coelho@avistacorp.com](mailto:Renee.Coelho@avistacorp.com)>; Dempsey, Tom <[Tom.Dempsey@avistacorp.com](mailto:Tom.Dempsey@avistacorp.com)>; Bryan, Todd <[todd.bryan@avistacorp.com](mailto:todd.bryan@avistacorp.com)>; 'phillip.popoff@pse.com' <[phillip.popoff@pse.com](mailto:phillip.popoff@pse.com)>; 'AshA@McKinstry.com' <[AshA@McKinstry.com](mailto:AshA@McKinstry.com)>; 'nancy@nwenergy.org' <[nancy@nwenergy.org](mailto:nancy@nwenergy.org)>; 'baz@pivotal-investments.com' <[baz@pivotal-investments.com](mailto:baz@pivotal-investments.com)>; 'dnightin@utc.wa.gov' <[dnightin@utc.wa.gov](mailto:dnightin@utc.wa.gov)>; Shane, Xin <[Xin.Shane@avistacorp.com](mailto:Xin.Shane@avistacorp.com)>; 'swalker@nrdc.org' <[swalker@nrdc.org](mailto:swalker@nrdc.org)>; 'jhuang@utc.wa.gov' <[jhuang@utc.wa.gov](mailto:jhuang@utc.wa.gov)>; Soyars, Darrell <[Darrell.Soyars@avistacorp.com](mailto:Darrell.Soyars@avistacorp.com)>; 'beverly.ikeda@pse.com' <[beverly.ikeda@pse.com](mailto:beverly.ikeda@pse.com)>; Miller, Joe <[Joe.Miller@avistacorp.com](mailto:Joe.Miller@avistacorp.com)>; 'david.wren@clearwaterpaper.com' <[david.wren@clearwaterpaper.com](mailto:david.wren@clearwaterpaper.com)>; 'Becky.King@chelanpud.org' <[Becky.King@chelanpud.org](mailto:Becky.King@chelanpud.org)>; Kimmell, Paul <[Paul.Kimmell@avistacorp.com](mailto:Paul.Kimmell@avistacorp.com)>; Lee, Lisa <[Lisa.Lee@avistacorp.com](mailto:Lisa.Lee@avistacorp.com)>; Tatko, Mike <[Mike.Tatko@avistacorp.com](mailto:Mike.Tatko@avistacorp.com)>; Trabun, Steve <[Steve.Trabun@avistacorp.com](mailto:Steve.Trabun@avistacorp.com)>; Vincent, Steve <[Steve.Vincent@avistacorp.com](mailto:Steve.Vincent@avistacorp.com)>; 'kirsten.wilson@des.wa.gov' <[kirsten.wilson@des.wa.gov](mailto:kirsten.wilson@des.wa.gov)>; 'tkhannon@comcast.net' <[tkhannon@comcast.net](mailto:tkhannon@comcast.net)>; 'Ductz@hotmail.com' <[Ductz@hotmail.com](mailto:Ductz@hotmail.com)>; 'magne.glide@comcast.net' <[magne.glide@comcast.net](mailto:magne.glide@comcast.net)>;

'wizfe@icehouse.net' <[wizfe@icehouse.net](mailto:wizfe@icehouse.net)>; 'bregher@pacbell.net' <[bregher@pacbell.net](mailto:bregher@pacbell.net)>; 'Blittle@huntwood.com' <[Blittle@huntwood.com](mailto:Blittle@huntwood.com)>; 'colin.conway@khco.com' <[colin.conway@khco.com](mailto:colin.conway@khco.com)>; 'nskuza@ewu.edu' <[nskuza@ewu.edu](mailto:nskuza@ewu.edu)>; Forsyth, Grant <[Grant.Forsyth@avistacorp.com](mailto:Grant.Forsyth@avistacorp.com)>; Bonfield, Shawn <[Shawn.Bonfield@avistacorp.com](mailto:Shawn.Bonfield@avistacorp.com)>; Steven Simmons <[SSimmons@NWCouncil.org](mailto:ssimmons@NWCouncil.org)>; Steiner, Nolan <[Nolan.Steiner@avistacorp.com](mailto:Nolan.Steiner@avistacorp.com)>; 'spittman@ameresco.com' <[spittman@ameresco.com](mailto:spittman@ameresco.com)>; 'johnf@inlandpower.com' <[johnf@inlandpower.com](mailto:johnf@inlandpower.com)>; 'CMcGuire@utc.wa.gov' <[CMcGuire@utc.wa.gov](mailto:CMcGuire@utc.wa.gov)>; Maher, Patrick <[Patrick.Maher@avistacorp.com](mailto:Patrick.Maher@avistacorp.com)>; Kinney, Scott <[Scott.Kinney@avistacorp.com](mailto:Scott.Kinney@avistacorp.com)>; Thackston, Jason <[jason.thackston@avistacorp.com](mailto:jason.thackston@avistacorp.com)>; Holland, Kevin <[Kevin.Holland@avistacorp.com](mailto:Kevin.Holland@avistacorp.com)>; Rothlin, John <[John.Rothlin@avistacorp.com](mailto:John.Rothlin@avistacorp.com)>; 'Melissa.Kaplan@clearwaterpaper.com' <[Melissa.Kaplan@clearwaterpaper.com](mailto:Melissa.Kaplan@clearwaterpaper.com)>; 'Brian.Dale@clearwaterpaper.com' <[Brian.Dale@clearwaterpaper.com](mailto:Brian.Dale@clearwaterpaper.com)>; 'deank@co.whitman.wa.us' <[deank@co.whitman.wa.us](mailto:deank@co.whitman.wa.us)>; 'arts@co.whitman.wa.us' <[arts@co.whitman.wa.us](mailto:arts@co.whitman.wa.us)>; 'Lance.Henderson@directenergy.com' <[Lance.Henderson@directenergy.com](mailto:Lance.Henderson@directenergy.com)>; 'cspc@shasta.com' <[cspc@shasta.com](mailto:cspc@shasta.com)>; 'doug.howell@sierraclub.org' <[doug.howell@sierraclub.org](mailto:doug.howell@sierraclub.org)>; McClatchey, Erin <[Erin.McClatchey@avistacorp.com](mailto:Erin.McClatchey@avistacorp.com)>; Elizabeth Osborne <[EOsborne@NWCouncil.org](mailto:EOsborne@NWCouncil.org)>; Gillian Charles <[GCharles@NWCouncil.org](mailto:GCharles@NWCouncil.org)>; 'EHiaasen@clatskaniepub.com' <[EHiaasen@clatskaniepub.com](mailto:EHiaasen@clatskaniepub.com)>; Fielder, Casey <[Casey.Fielder@avistacorp.com](mailto:Casey.Fielder@avistacorp.com)>; Kacalek, Sean <[Sean.Kacalek@avistacorp.com](mailto:Sean.Kacalek@avistacorp.com)>; Browne, Terrence <[Terrence.Browne@avistacorp.com](mailto:Terrence.Browne@avistacorp.com)>; 'merle.pedersen@perennialpower.net' <[merle.pedersen@perennialpower.net](mailto:merle.pedersen@perennialpower.net)>; Sprague, Collins <[Collins.Sprague@avistacorp.com](mailto:Collins.Sprague@avistacorp.com)>; 'bcebulko@utc.wa.gov' <[bcebulko@utc.wa.gov](mailto:bcebulko@utc.wa.gov)>; Schlect, Jeff <[jeff.schlect@avistacorp.com](mailto:jeff.schlect@avistacorp.com)>; 'joni@nwenergy.org' <[joni@nwenergy.org](mailto:joni@nwenergy.org)>; 'botto@idahoconservation.org' <[botto@idahoconservation.org](mailto:botto@idahoconservation.org)>; 'Daniel.Howlett@energykeepersinc.com' <[Daniel.Howlett@energykeepersinc.com](mailto:Daniel.Howlett@energykeepersinc.com)>; 'Travis.Togo@energykeepersinc.com' <[Travis.Togo@energykeepersinc.com](mailto:Travis.Togo@energykeepersinc.com)>; 'doug\_krapas@iepc.com' <[doug\\_krapas@iepc.com](mailto:doug_krapas@iepc.com)>; 'kevind@iepc.com' <[kevind@iepc.com](mailto:kevind@iepc.com)>; 'honekamp@snapwa.org' <[honekamp@snapwa.org](mailto:honekamp@snapwa.org)>; Howard, Bruce <[Bruce.Howard@avistacorp.com](mailto:Bruce.Howard@avistacorp.com)>; Magalsky, Kelly <[Kelly.Magalsky@avistacorp.com](mailto:Kelly.Magalsky@avistacorp.com)>; 'nathan.weller@Pullman-Wa.gov' <[nathan.weller@Pullman-Wa.gov](mailto:nathan.weller@Pullman-Wa.gov)>; 'simonj@gonzaga.edu' <[simonj@gonzaga.edu](mailto:simonj@gonzaga.edu)>; 'jorgendr@gmail.com' <[jorgendr@gmail.com](mailto:jorgendr@gmail.com)>; Andrea, Michael <[Michael.Andrea@avistacorp.com](mailto:Michael.Andrea@avistacorp.com)>; 'christopher.galland@ge.com' <[christopher.galland@ge.com](mailto:christopher.galland@ge.com)>; Tina Jayaweera <[TJayaweera@NWCouncil.org](mailto:TJayaweera@NWCouncil.org)>; 'Tiffany.Floyd@deq.idaho.gov' <[Tiffany.Floyd@deq.idaho.gov](mailto:Tiffany.Floyd@deq.idaho.gov)>; 'Carl.Brown@deq.idaho.gov' <[Carl.Brown@deq.idaho.gov](mailto:Carl.Brown@deq.idaho.gov)>; 'shauna@pnucc.org' <[shauna@pnucc.org](mailto:shauna@pnucc.org)>; 'UTCenerg@utc.wa.gov' <[UTCenerg@utc.wa.gov](mailto:UTCenerg@utc.wa.gov)>; 'john.robbs@wartsila.com' <[john.robbs@wartsila.com](mailto:john.robbs@wartsila.com)>; Dillon, Mike <[Mike.Dillon@avistacorp.com](mailto:Mike.Dillon@avistacorp.com)>; 'Yao.Yin@puc.idaho.gov' <[Yao.Yin@puc.idaho.gov](mailto:Yao.Yin@puc.idaho.gov)>; Pardee, Tom <[Tom.Pardee@avistacorp.com](mailto:Tom.Pardee@avistacorp.com)>; 'UTCenerg@utc.wa.gov' <[UTCenerg@utc.wa.gov](mailto:UTCenerg@utc.wa.gov)>; 'cwright@utc.wa.gov' <[cwright@utc.wa.gov](mailto:cwright@utc.wa.gov)>; 'dhschaub@gmail.com' <[dhschaub@gmail.com](mailto:dhschaub@gmail.com)>; Finesilver, Ryan <[Ryan.Finesilver@avistacorp.com](mailto:Ryan.Finesilver@avistacorp.com)>; 'amy@nwenergy.org' <[amy@nwenergy.org](mailto:amy@nwenergy.org)>; 'tomas@pnucc.org' <[tomas@pnucc.org](mailto:tomas@pnucc.org)>; 'bkathrens@hotmail.com' <[bkathrens@hotmail.com](mailto:bkathrens@hotmail.com)>; 'esteb44@centurylink.net' <[esteb44@centurylink.net](mailto:esteb44@centurylink.net)>; 'Michael.Eldred@puc.idaho.gov' <[Michael.Eldred@puc.idaho.gov](mailto:Michael.Eldred@puc.idaho.gov)>; 'gsnow@pera-inc.com' <[gsnow@pera-inc.com](mailto:gsnow@pera-inc.com)>; 'jmletellier48@gmail.com' <[jmletellier48@gmail.com](mailto:jmletellier48@gmail.com)>; 'phil@philjonesconsulting.com' <[phil@philjonesconsulting.com](mailto:phil@philjonesconsulting.com)>; 'CoreyD@ATG.WA.GOV' <[CoreyD@ATG.WA.GOV](mailto:CoreyD@ATG.WA.GOV)>; 'kmaracas@comcast.net' <[kmaracas@comcast.net](mailto:kmaracas@comcast.net)>; 'bparker.work@gmail.com' <[bparker.work@gmail.com](mailto:bparker.work@gmail.com)>; Schuh, Karen <[Karen.Schuh@avistacorp.com](mailto:Karen.Schuh@avistacorp.com)>; 'kathlyn.kinney@gmail.com' <[kathlyn.kinney@gmail.com](mailto:kathlyn.kinney@gmail.com)>; 'brian.g.henning@gmail.com' <[brian.g.henning@gmail.com](mailto:brian.g.henning@gmail.com)>; 'kelly@climatesolutions.org' <[kelly@climatesolutions.org](mailto:kelly@climatesolutions.org)>; 'david.nightingale@utc.wa.gov' <[david.nightingale@utc.wa.gov](mailto:david.nightingale@utc.wa.gov)>; 'Rachelle.Farnsworth@puc.idaho.gov' <[Rachelle.Farnsworth@puc.idaho.gov](mailto:Rachelle.Farnsworth@puc.idaho.gov)>; 'Terri.Carlock@puc.idaho.gov' <[Terri.Carlock@puc.idaho.gov](mailto:Terri.Carlock@puc.idaho.gov)>; 'tedesco@spokanetribe.com' <[tedesco@spokanetribe.com](mailto:tedesco@spokanetribe.com)>; Schultz, Kaylene <[Kaylene.Schultz@avistacorp.com](mailto:Kaylene.Schultz@avistacorp.com)>; 'jennifer.snyder@utc.wa.gov' <[jennifer.snyder@utc.wa.gov](mailto:jennifer.snyder@utc.wa.gov)>; Tyrie, Mary <[Mary.Tyrie@avistacorp.com](mailto:Mary.Tyrie@avistacorp.com)>; 'John.Chatburn@oer.idaho.gov' <[John.Chatburn@oer.idaho.gov](mailto:John.Chatburn@oer.idaho.gov)>; 'eric@4sighteng.com' <[eric@4sighteng.com](mailto:eric@4sighteng.com)>; Rose, Melanie <[Melanie.Rose@avistacorp.com](mailto:Melanie.Rose@avistacorp.com)>; 'kara@measurepnw.com' <[kara@measurepnw.com](mailto:kara@measurepnw.com)>; 'Nathan.Sandvig@nationalgrid.com' <[Nathan.Sandvig@nationalgrid.com](mailto:Nathan.Sandvig@nationalgrid.com)>; 'zentzlaw@gmail.com' <[zentzlaw@gmail.com](mailto:zentzlaw@gmail.com)>; 'jbtaylor@tesla.com' <[jbtaylor@tesla.com](mailto:jbtaylor@tesla.com)>; 'eforbes@tesla.com' <[eforbes@tesla.com](mailto:eforbes@tesla.com)>; 'zach.genta@clenera.com' <[zach.genta@clenera.com](mailto:zach.genta@clenera.com)>; 'fred@nwenergy.org' <[fred@nwenergy.org](mailto:fred@nwenergy.org)>; 'Kevin.Keyt@puc.idaho.gov' <[Kevin.Keyt@puc.idaho.gov](mailto:Kevin.Keyt@puc.idaho.gov)>; 'sherber@idahoconservation.org' <[sherber@idahoconservation.org](mailto:sherber@idahoconservation.org)>; 'chipestes@gmail.com' <[chipestes@gmail.com](mailto:chipestes@gmail.com)>; Brown, Garrett <[Garrett.Brown@avistacorp.com](mailto:Garrett.Brown@avistacorp.com)>; Ericksen, Ryan <[Ryan.Ericksen@avistacorp.com](mailto:Ryan.Ericksen@avistacorp.com)>; 'Jim.Yockey@bakertilly.com'

<[Jim.Yockey@bakertilly.com](mailto:Jim.Yockey@bakertilly.com)>; 'dzentz@spokanecity.org' <[dzentz@spokanecity.org](mailto:dzentz@spokanecity.org)>; 'emcase@heelstoneenergy.com' <[emcase@heelstoneenergy.com](mailto:emcase@heelstoneenergy.com)>; 'dzentz@spokanecity.org' <[dzentz@spokanecity.org](mailto:dzentz@spokanecity.org)>; 'lcallen@spokanecity.org' <[lcallen@spokanecity.org](mailto:lcallen@spokanecity.org)>; 'colsen@spokanecity.org' <[colsen@spokanecity.org](mailto:colsen@spokanecity.org)>; 'aargetsinger@tyrenergy.com' <[aargetsinger@tyrenergy.com](mailto:aargetsinger@tyrenergy.com)>; 'kcalhoon@tyrenergy.com' <[kcalhoon@tyrenergy.com](mailto:kcalhoon@tyrenergy.com)>; 'dnh@mrwassoc.com' <[dnh@mrwassoc.com](mailto:dnh@mrwassoc.com)>; 'glehman@stratasolar.com' <[glehman@stratasolar.com](mailto:glehman@stratasolar.com)>; 'Justin.Cowley@clearwaterpaper.com' <[Justin.Cowley@clearwaterpaper.com](mailto:Justin.Cowley@clearwaterpaper.com)>; 'richard@tollhouseenergy.com' <[richard@tollhouseenergy.com](mailto:richard@tollhouseenergy.com)>; 'jhansen@idahopower.com' <[jhansen@idahopower.com](mailto:jhansen@idahopower.com)>; Kimball, Paul <[Paul.Kimball@avistacorp.com](mailto:Paul.Kimball@avistacorp.com)>; 'nikita.bankoti@utc.wa.gov' <[nikita.bankoti@utc.wa.gov](mailto:nikita.bankoti@utc.wa.gov)>; 'kate.griffith@utc.wa.gov' <[kate.griffith@utc.wa.gov](mailto:kate.griffith@utc.wa.gov)>; Hermanson, Lori <[Lori.Hermanson@avistacorp.com](mailto:Lori.Hermanson@avistacorp.com)>; Ghering, Amanda <[amanda.ghering@avistacorp.com](mailto:amanda.ghering@avistacorp.com)>; 'andresalvarez@creativerenewablesolutions.com' <[andresalvarez@creativerenewablesolutions.com](mailto:andresalvarez@creativerenewablesolutions.com)>; 'gerryfroese@creativerenewablesolutions.com' <[gerryfroese@creativerenewablesolutions.com](mailto:gerryfroese@creativerenewablesolutions.com)>; 'Peter.Sawicki@amer.mhps.com' <[Peter.Sawicki@amer.mhps.com](mailto:Peter.Sawicki@amer.mhps.com)>; McDougall, James <[James.McDougall@avistacorp.com](mailto:James.McDougall@avistacorp.com)>; 'boleneus@gmail.com' <[boleneus@gmail.com](mailto:boleneus@gmail.com)>; Gross, John <[John.Gross@avistacorp.com](mailto:John.Gross@avistacorp.com)>; Fisher, Damon <[Damon.Fisher@avistacorp.com](mailto:Damon.Fisher@avistacorp.com)>; Spratt, Dean <[Dean.Spratt@avistacorp.com](mailto:Dean.Spratt@avistacorp.com)>; 'vlad@climatesolutions.org' <[vlad@climatesolutions.org](mailto:vlad@climatesolutions.org)>; 'dgibson@idahoconservation.org' <[dgibson@idahoconservation.org](mailto:dgibson@idahoconservation.org)>; Daniel Hua <[DHua@NWCouncil.org](mailto:DHua@NWCouncil.org)>; 'katie@renewablenw.org' <[katie@renewablenw.org](mailto:katie@renewablenw.org)>; 'mark@spokenergy.com' <[mark@spokenergy.com](mailto:mark@spokenergy.com)>; 'max@renewablenw.org' <[max@renewablenw.org](mailto:max@renewablenw.org)>; 'teoacioe@comcast.net' <[teoacioe@comcast.net](mailto:teoacioe@comcast.net)>; 'Katie.Pegan@oer.idaho.gov' <[Katie.Pegan@oer.idaho.gov](mailto:Katie.Pegan@oer.idaho.gov)>; 'Morgan.Brummund@oer.idaho.gov' <[Morgan.Brummund@oer.idaho.gov](mailto:Morgan.Brummund@oer.idaho.gov)>; 'gavin@northwestrenewables.com' <[gavin@northwestrenewables.com](mailto:gavin@northwestrenewables.com)>; Brandon, Annette <[Annette.Brandon@avistacorp.com](mailto:Annette.Brandon@avistacorp.com)>; 'janh@biaw.com' <[janh@biaw.com](mailto:janh@biaw.com)>; 'Shay.Bauman@atg.wa.gov' <[Shay.Bauman@atg.wa.gov](mailto:Shay.Bauman@atg.wa.gov)>; 'brianfadie@gmail.com' <[brianfadie@gmail.com](mailto:brianfadie@gmail.com)>; 'mbarlow@newsunenergy.net' <[mbarlow@newsunenergy.net](mailto:mbarlow@newsunenergy.net)>; Majure, Jaime <[Jaime.Majure@avistacorp.com](mailto:Jaime.Majure@avistacorp.com)>; 'IMcGetrick@idahopower.com' <[IMcGetrick@idahopower.com](mailto:IMcGetrick@idahopower.com)>; 'SMcNeilly@idahopower.com' <[SMcNeilly@idahopower.com](mailto:SMcNeilly@idahopower.com)>; 'KFlynn@idahopower.com' <[KFlynn@idahopower.com](mailto:KFlynn@idahopower.com)>; 'Mike.Louis@puc.idaho.gov' <[Mike.Louis@puc.idaho.gov](mailto:Mike.Louis@puc.idaho.gov)>; 'Donn.English@puc.idaho.gov' <[Donn.English@puc.idaho.gov](mailto:Donn.English@puc.idaho.gov)>; 'Mike.Morrison@puc.idaho.gov' <[Mike.Morrison@puc.idaho.gov](mailto:Mike.Morrison@puc.idaho.gov)>; 'Ricky.Davis@clearwayenergy.com' <[Ricky.Davis@clearwayenergy.com](mailto:Ricky.Davis@clearwayenergy.com)>; 'ben.metcalfe@galeheaddev.com' <[ben.metcalfe@galeheaddev.com](mailto:ben.metcalfe@galeheaddev.com)>; 'glenn.blackmon@commerce.wa.gov' <[glenn.blackmon@commerce.wa.gov](mailto:glenn.blackmon@commerce.wa.gov)>

**Subject:** Avista's Draft 2021 Electric IRP

Hello TAC Members,

Attached is a copy of the draft 2021 Electric IRP for your review. Please provide any comments or edits back to us by Monday, March 1, 2021 to me at [john.lyons@avistacorp.com](mailto:john.lyons@avistacorp.com). The final IRP and completed appendices will be filed on April 1, 2021 with the Idaho and Washington Commissions.

Our fifth and final TAC meeting will be held on Thursday, January 21, 2021. The meeting invitation and agenda will be available by the end of this week. There will also be an opportunity to provide written comments about the draft IRP to the Washington Commission and a public meeting on February 23, 2020. We will provide more details at the fifth TAC meeting.

Thank you for all of your participation in the 2021 IRP,

John Lyons  
Avista Corp.  
509-495-8515

CONFIDENTIALITY NOTICE: The contents of this email message and any attachments are intended solely for the addressee(s) and may contain confidential and/or privileged information and may be legally protected from disclosure. If you are not the intended recipient of this message or an agent of the intended recipient, or if this message has been addressed to you in error, please immediately alert the sender by reply email and then delete this message and any attachments.

**USE CAUTION - EXTERNAL SENDER**

**Do not click on links or open attachments that are not familiar.**

**For questions or concerns, please e-mail [phishing@avistacorp.com](mailto:phishing@avistacorp.com)**

February 5, 2021

Mark Johnson  
 Executive Director and Secretary  
 Washington Utilities and Transportation Commission  
 621 Woodland Square Loop SE  
 Lacey, WA 98504-7250

Received  
 Records Management  
 02/05/21 16:55  
 State Of WASH.  
 UTIL. AND TRANSP.  
 COMMISSION

**RE: Comments of Renewable Northwest, Docket UE-200301**

Utilities and Transportation Commission’s January 5, 2021, Notice of Opportunity to File Written Comments Relating to Avista’s 2021 Draft Integrated Resource Plan for Electricity, Docket UE-200301.

**I. INTRODUCTION**

Renewable Northwest thanks the Washington Utilities and Transportation Commission (“the Commission”) for this opportunity to comment in response to the Commission’s January 5, 2021, Notice of Opportunity (“Notice”) to File Written Comments relating to Avista Corporation d/b/a Avista Utilities’ (“Avista” or “the Company”) 2021 Draft Integrated Resource Plan (“Draft IRP”) for Electricity, published January 4, 2021.

Renewable Northwest participated in Avista’s Technical Advisory Committee (“TAC”) meetings during development of the Draft IRP, and we were generally pleased with the Company’s consideration of stakeholder input during its public participation phase. Still, we have noted in these comments various areas for improvement in the Draft IRP for Avista and the Commission to consider, bearing in mind the important role of this IRP to plan for compliance with the clean energy standards of Washington’s Clean Energy Transformation Act (“CETA”), and as such, to inform Avista’s first Clean Energy Implementation Plan (“CEIP”), set to be published later this year.<sup>1</sup>

In these comments, we identify areas where Avista’s Draft IRP does not align with the most current resource costs and characteristics. We offer recommendations for revising Avista’s flexibility analysis, resource adequacy considerations, and sensitivity analyses with the goal of nudging the Company toward a least-cost portfolio with the best likelihood of meeting CETA’s clean energy standards.

---

<sup>1</sup> WAC 480-100-640

Finally, we appreciate Avista’s commitment to achieving carbon neutrality in its electric operations by 2027 and to provide customers with one hundred percent carbon-free electricity by 2045.<sup>2</sup> We think the Company is making strides in creating a path toward meeting those goals, but we urge Avista and the Commission to consider where the Draft IRP may be hindered by traditional resource planning assumptions not relevant to an energy transformation toward a dynamic mix of non-emitting resources. We look forward to continued participation in the development of Avista’s 2021 IRP.

## II. COMMENTS

### A. Regulatory Context

CETA broadly requires Washington utilities to achieve greenhouse gas neutrality by 2030 and to serve Washington customers with one hundred percent non-emitting and renewable electricity by 2045.<sup>3</sup> Utilities must identify steps to achieve these standards using the new tool of Clean Energy Implementation Plans, and those CEIPs must in turn “identify specific actions to be taken by the investor-owned utility over the next four years, *consistent with the utility's long-range integrated resource plan* and resource adequacy requirements, that demonstrate progress toward meeting the standards under RCW 19.405.040(1) and 19.405.050(1)” as well as interim targets to ensure incremental progress.<sup>4</sup>

The Commission worked for months with many stakeholders, including Renewable Northwest, to craft new rules aligning utility IRPs with CEIPs and CETA’s substantive requirements. These new rules point to some key downstream effects of IRPs: first, “[t]he commission will consider the information reported in the integrated resource plan when it evaluates the performance of the utility in rate and other proceedings”<sup>5</sup>; and second, a utility’s “CEIP must describe how [its] specific actions ... [a]re consistent with the utility's integrated resource plan.”<sup>6</sup> The main takeaway of this structure is that it is important to get as much correct as possible in the IRP, as analytical missteps could have repercussions both for utility cost recovery and for achieving CETA’s critically important substantive standards.

With that backdrop in mind, we offer the following comments on Avista’s Draft IRP, assessing elements of the Draft IRP not only against specific provisions of the Commission’s rules as

---

<sup>2</sup> Avista Connections, *available at* <https://www.myavista.com/connect/articles/2019/08/this-is-clean-energy-for-the-future>.

<sup>3</sup> RCW 19.405.040(1) & 19.405.050(1) (emphasis added).

<sup>4</sup> RCW 19.405.060(1)(b)(iii).

<sup>5</sup> WAC 480-100-238(6).

<sup>6</sup> WAC 480-100-640(6)(d).

appropriate, but also against the broader context of how the information in this IRP will be used in future planning, procurement, and ultimately cost recovery efforts.

## B. Supply Side Resource Options

### Assumptions

Avista may have rounded up its solar capital costs, judging by current estimates, but the Company should consider revising its solar capital costs to reflect the slightly lower values estimated at this time. For example, Lazard’s Levelized Cost of Energy Analysis for 2020 estimates solar capital costs to lie in the range of \$825 to \$975.<sup>7</sup>

Considering Avista’s assumptions for lithium-ion battery storage, we recommend the Company review the data informing the levelized cost (\$/kW) for the preferred 4-hour lithium-ion battery, as there appears to be a gradual price increase after 2033 rather than a steady decline, which would be expected.<sup>8</sup> For example, the National Renewable Energy Laboratory’s (“NREL”) 2020 Annual Technology Baseline (“ATB”) reports a trend of cost reductions (illustrated as \$/kW in *Figure 1*) through to 2050.

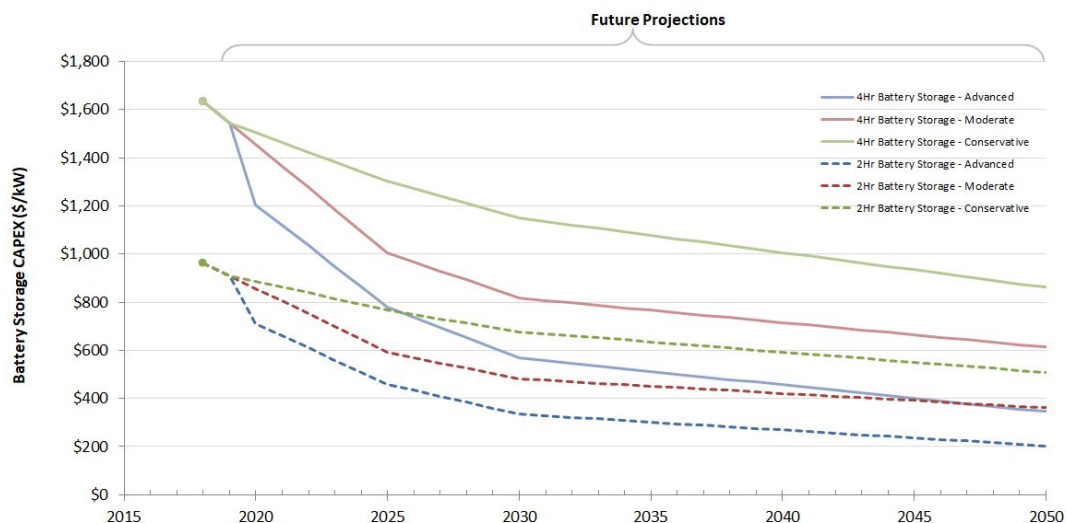

**Figure 1.** Li-ion battery storage projection (in \$/kW) from NREL’s Annual Technology Baseline 2020.<sup>9</sup>

<sup>7</sup> See, e.g., Lazard’s Levelized Cost of Energy Analysis (Oct. 2020), at 11, available at <https://www.lazard.com/media/451419/lazards-levelized-cost-of-energy-version-140.pdf>.

<sup>8</sup> Table 9.7. Lithium-ion Levelized Cost \$/kW, p. 9-14

<sup>9</sup> Battery Storage cost values from W. Cole and A. W. Frazier, “Cost Projections for Utility-scale Battery Storage: 2020 Update,” NREL/TP-6A20-75385. Golden, CO: National Renewable Energy Laboratory, available at <https://www.nrel.gov/docs/fy20osti/75385.pdf>.

### Ancillary Services Value

We appreciate Avista’s proactive approach in valuing ancillary services of emerging resources using sub-hourly modeling. Because there are a number of impending questions that the Company is working through, the comments provided below will shed some light on the broader concept of system flexibility and how emerging resources are able to provide the flexibility needs arising from an increasing share of renewable resources in a reliable manner.

Flexibility has always been part of power system operation because the normal demand for electricity varies significantly on a daily and seasonal basis. Traditional approaches to planning have supported flexibility that is sufficient to meet load reliably. However, increasing renewable generation sources may make traditional approaches to planning inadequate to ensure sufficient flexibility. System flexibility can be characterized along four dimensions: first, the ***absolute power output capacity*** range (in “MW”); second, the ***speed of power output change***, or ramp rate (in “MW/min”); third, the ***duration of energy levels*** (in “MWh”); and finally the ***carbon intensity*** (in “CO<sub>2</sub>e/MWh”). Resources which have a larger range between their minimum and maximum “MW” output, such as pumped-hydro storage systems, can provide the flexibility to adjust to a wider range of power system conditions. Resources that can change their output quickly or can be easily turned on or off, including 2-, 4- & 6-hour lithium-ion, flow battery storage systems and demand response (“DR”), have a higher ramp rate and are more flexible because they adjust faster to changes in power system conditions. Resources which can deliver energy for longer durations increase flexibility because they can address prolonged disturbances or outages. Resources such as conventional combustion turbines and combined cycle can provide dispatchable power but have low capacity utilization and are emission-intensive when ramped up or down rapidly. These different dimensions are important to consider in any holistic flexibility analysis and, thus, in calculating benefits, considering not just the frequency of flex violations but their magnitude, speed, duration, and carbon intensity.

In addition to the ADSS system, we recommend the use of the PLEXOS model to simulate generation on a sub-hourly timescale to calculate the balancing reserve requirements and the associated system costs and benefits to meet those intra-hourly dispatch requirements, as legally enforced through NERC’s BAL series standards. As defined in BAL-005.5, each Balancing Authority Area is required to have Automatic Generation Control (“AGC”), calculate Area Control Error (“ACE”), and deploy balancing reserves to balance resources and demand. It is important to recognize that with the changing supply-and-demand paradigm, flexibility needs are changing as system variability migrates from load to generation. With Avista’s participation in the Energy Imbalance Market (“EIM”), it has the ability to tap into the diversity benefits of multiple resources to balance their demand and supply.



At the same time, new technologies (such as controllable solar and wind power plants, battery storage systems, pumped-hydro systems, and demand response resources) and operational practices provide new options for flexibility. These emerging needs and solutions increase the benefit of a transparent flexibility value, which can help system operators efficiently maintain reliability and enable market participants to make informed investments. Controllable solar and wind power plants have the ability to respond to dispatch instructions much more quickly than conventional generators, in addition to having a zero variable cost. “Flexible solar” not only contributes to solving operating challenges related to solar variability but can also provide grid services, essentially creating dispatchable renewable power plants.<sup>10</sup> A similar study was conducted by Avangrid, NREL, and GE showing that a utility-scale wind power plant can provide regulation-up, regulation-down, and other grid services.<sup>11</sup> Since the flexibility benefit is calculated based on the difference between “day-ahead” and “intra-hour” dispatch, resources with zero variable cost and fast response times, like controllable renewable, battery storage, demand response and pumped-hydro, would generate much higher values than conventional thermal resources.<sup>12</sup> In addition, it has also been proven through many studies that geographical resource diversity and aggregation reduce the need for reserve requirements by reducing short-term variability.<sup>13</sup>

In conclusion, we appreciate the effort Avista has put into modeling ancillary services and providing draft results to stakeholders, but we recommend additional considerations to (i) operational flexibility (both up & down) offered by controllable solar and wind power plants, (ii) detailed analysis of multiple lithium-ion battery durations to the flexibility resource options, (iii) the modeling of sensitivities around the nameplate capacity of flexible resources, and (iv) the draft value of “diversity savings” from participation in the EIM. In addition, it would be useful to see different dimensions of the flex violations and how they are being addressed using the fleet of resources modeled in the flex analysis conducted using PLEXOS. We are also interested to view the flex benefit results coming out of the modeling for pumped-hydro and DR resources, which we believe would be higher than conventional solutions to provide the necessary intra-hourly supply and load flexibility.

### Resource ELCC Analysis

<sup>10</sup> Investigating the Economic Value of Flexible Solar Power Plant Operation First Solar & E# Study. October 2018. <https://www.ethree.com/wp-content/uploads/2018/10/Investigating-the-Economic-Value-of-Flexible-Solar-Power-Plant-Operation.pdf>

<sup>11</sup> Avangrid Renewables: Demonstration of Capability to Provide Essential Grid Services.. <http://www.caiso.com/Documents/WindPowerPlantTestResults.pdf>

<sup>12</sup> Determining Utility System Value of Demand Flexibility From Grid-interactive Efficient Buildings. <https://pubs.naruc.org/pub/2E1DDEEC-155D-0A36-3137-0FC3D941B1A4>

<sup>13</sup> Ancillary Service and Balancing Authority Area Solutions to Integrate Variable Generation. Available at: <https://www.nerc.com/files/ivgtf2-3.pdf>

While we appreciate the detailed analysis that Avista has conducted and the provision of peak capacity credit values for different supply side resource options, we are concerned that these values significantly under value storage and hybrid resources.

To start, the Draft IRP references an E3 report in stating that, “4-hour duration storage can provide high levels of resource adequacy in small quantities because it has other resources to assist in its re-charging; but as its proportion gets larger, there is not enough energy to refill the storage device for later dispatch.”<sup>14</sup> This statement is confusing and misrepresents operating characteristics and values of energy storage systems. As we know, reliability should be valued during the times when the system is in stress (i.e. hours with the highest probability of loss of load). As Avista mentions, 4-hour duration storage can provide high levels of resource adequacy. The quantity of adequacy depends on the operating characteristics of the power plant and how it is being operated to meet the reliability risks. In addition, storage capacity can be easily refilled during off-peak hours when solar and wind are usually curtailed (mid-morning for solar and late night for wind), either directly or indirectly, from the grid. It is also worth noting that hybrid resources are not physically restricted to charge from the renewable component since the Federal Investment Tax Credit (ITC) is a financial not a physical restriction. Thus, a power plant operator may choose to charge the storage partially from the grid to ensure that it meets the capacity requirement during critical periods.

The Draft IRP also mentions that “[h]igher levels of penetrations for renewables may lower their effect on resource adequacy.” While this statement is true due to diminishing marginal ELCC from increasing penetration of renewables, it is also true that the capacity credit of storage increases with increasing penetration of renewables since they are complementary resources, by changing the shape of net demand patterns and effectively shifting delivery of energy to meet the reliability needs.<sup>15</sup> An analysis conducted by Astrape Consulting commission by joint IOUs in California showed that solar paired with 4-hour storage provides greater than 95% ELCC on average including analysis and values pertaining to the BPA region.<sup>16</sup> Avista’s value provided in Table 9.12 shows a 17% value which is extremely low based on recent IRP filings and technical reports in the region. Therefore, we recommend Avista study for its final IRP the different operational configurations and characteristics of hybrid resources and standalone storage to correctly evaluate the resource ELCC value.

---

<sup>14</sup> P. 9-27

<sup>15</sup> The Potential for Battery Energy Storage to Provide Peaking Capacity in the United States. Denholm et al, 2019. Available at:

<https://www.osti.gov/biblio/1530173-potential-battery-energy-storage-provide-peaking-capacity-united-states>

<sup>16</sup> 2020 Joint CA IOU ELCC Study Report 1. Astrape Consulting. August 2020. Available at:

<https://www.astrape.com/2020-joint-ca-iou-elcc-study-report-1/>

### C. Preferred Resource Strategy

To begin, we request that Avista incorporate the results of its 2020 Renewable RFP in the preferred resource strategy (“PRS”) for its final IRP, including how Avista’s improved knowledge of current market prices may adjust resource assumptions informing the 2021 IRP model.

We appreciate Avista’s transparency in revealing that the early economic contractual exit from Colstrip Units 3 & 4 would benefit its Washington and Idaho customers. If the joint owners of this resource were to agree on the terms of early exit from or retirement of these units, it would in part be because of this modeling effort by Avista. However, we recognize the complexity of exiting a jointly-owned resource, and we understand Avista’s decision to maintain the 2025 Colstrip exit date in its PRS.

As indicated above, Avista may be undervaluing storage and hybrid resources, especially considering Washington’s and the entire region’s transition away from fossil resources, thus increasing the penetration of renewables on the grid and the capacity credit of storage. Avista does note their intention to study additional benefits of storage by modeling additional scenarios including price and renewable penetration.<sup>17</sup> We hope Avista will conduct these analyses to inform the PRS of the final IRP, as we urge the Company and the Commission to acknowledge that traditional methods of resource planning -- especially those driving standards for determining resource adequacy -- will likely continue to favor new natural gas builds and delay the clean energy transition.

Avista mentions throughout the Draft IRP that upon exit from coal contracts by 2025, limited capacity options are available as replacement. For example, Avista notes, “With the exit of Colstrip and the expiration of the Lancaster PPA in the fall of 2026, the PRS adds 211 MW of natural gas-fired CTs. The 2020 IRP assumed the capacity lost from Colstrip and Lancaster could be met with long duration pumped hydro, but the updated cost and construction schedule information for pumped hydro caused this resource to not be selected in this IRP.”<sup>18</sup> For the Commission and stakeholders to better understand why Avista’s capacity needs can only be met with new natural gas peaking capacity, we recommend that Avista provide at its upcoming TAC meeting or publish in its final IRP a projected loss-of-load event, displaying by hour where there is a deficiency in available capacity. This could be in the form of a 12x24 matrix of the peak demand or hours with the highest loss of load probability which were used to calculate the ELCC values for all resources.<sup>19</sup>

---

<sup>17</sup> P. 9-26

<sup>18</sup> P. 11-5

<sup>19</sup> See, e.g., Energy+Environmental Economics (E3), “Capacity Value Framework & Allocation Options,” Oregon

#### D. Portfolio Scenario Analysis

While there is certainly value in many of Avista’s twenty modeled sensitivities, we recommend the Company conduct one additional analysis to better understand how policy-driven changes in Avista’s resource mix should impact the way the Company plans for meeting demand reliably and at least cost. For example, especially considering our previous comments regarding pricing and ELCC values for storage resources, a sensitivity analysis of must-take storage (not limited by resource type or duration characteristics) combinations in place of new natural gas peaking plants would inform Avista how much current storage technologies would change levelized portfolio costs. Avista’s Portfolio #5 -- “Clean Resource Plan (2027)” -- does not prohibit new gas procurements, and Portfolio #6 -- “Clean Resource Plan (2045)” -- does prohibit new gas procurements but curiously allows Colstrip to exit at any time.<sup>20</sup>

### III. CONCLUSION

Renewable Northwest thanks Avista and the Commission for its consideration of this feedback. We are optimistic that the changes and additional analysis we have recommended above will help Avista to identify a least-cost portfolio that also puts the Company on a path to achieving CETA’s clean energy standards and the company’s own emission reduction goals. We look forward to continued engagement as a stakeholder in this 2021 IRP process.

Sincerely,

/s/ Katie Ware

Katie Ware

Washington Policy Manager

Renewable Northwest

[katie@renewablenw.org](mailto:katie@renewablenw.org)

/s/ Sashwat Roy

Sashwat Roy

Technology & Policy Analyst

Renewable Northwest

[sashwat@renewablenw.org](mailto:sashwat@renewablenw.org)

/s/ Max Greene

Max Greene

Regulatory & Policy Director

Renewable Northwest

[max@renewablenw.org](mailto:max@renewablenw.org)

---

Public Utilities Commission (UM 2011) at slide 39 (Jul. 9, 2020), *available at* <https://edocs.puc.state.or.us/efdocs/HAH/um2011hah17397.pdf>.

<sup>20</sup> P. 12-6

February 5, 2021

Puget Sound Energy  
355 110<sup>th</sup> Ave NE  
Bellevue, WA 98004

Received  
Records Management  
02/05/21 13:59  
State Of WASH.  
UTIL. AND TRANSP.  
COMMISSION

**RE: Comments of Swan Lake and Goldendale  
Avista Corporation – Draft Integrated Resource Plan  
UTC Docket UE-200301**

The companies working to develop the Swan Lake and Goldendale pumped hydro storage projects (“Swan Lake and Goldendale”) appreciate Avista Corporation’s (“Avista”) work that went into preparing its draft Integrated Resource Plan (“Draft IRP”), which was filed in the above-referenced proceeding on January 4, 2021. The Washington Utilities and Transportation Commission (“Commission”) subsequently issued a notice, on January 5, 2021, indicating it would accept comments on Avista’s Draft IRP until February 5, 2021.<sup>1</sup> In response to that notice, Swan Lake and Goldendale are filing these comments.

These comments advocate for Avista to further consider pumped storage resources instead of new natural gas facilities, which are politically infeasible to build and do not align with Washington State’s Clean Energy Transformation Act (“CETA” requirements. Specifically, these comments: (1) seek further information regarding Avista’s modeling and assumptions for pumped storage; (2) argue that Avista should not seek to construct new gas facilities, given the current political realities associated with new gas facilities and CETA’s requirements; and (3) advocate for Avista to issue a capacity request for proposals (“RFP”) as soon as possible, as an RFP is the only mechanism through which Avista will receive accurate pricing and capacity proposals, particularly for large resources like pumped storage.

## **I. Overview of Pumped Storage in the Draft IRP**

According to Avista’s Draft IRP, long duration pumped hydro storage was identified as the capacity resource to meet future long duration deficits; however, it appears the Draft IRP did not include them in the Preferred Resource Strategy because “long duration pumped hydro is likely available later than the timelines used in the 2020 IRP and at higher costs.”<sup>2</sup> As a result, the Draft IRP states, “The resource analysis identifies a natural gas CT to replace resource deficits if pumped hydro is not a feasible resource to meet the 2026 shortfall.”<sup>3</sup> These statements suggest that pumped storage was Avista’s preferred resource, if not for a mismatch in timing and updated cost figures.

<sup>1</sup> Notice of Opportunity to File Written Comments, Docket UE-200301, Jan. 5, 2021, available at: <https://www.utc.wa.gov/layouts/15/CasesPublicWebsite/GetDocument.ashx?docID=11&year=2020&docketNumber=200301>.

<sup>2</sup> Draft IRP at 14-5.

<sup>3</sup> *Id.*

Through these comments, Swan Lake and Goldendale suggest that Avista reconsider including pumped storage in its Preferred Resource Strategy. Specifically, as further explained below, Swan Lake and Goldendale are two of the most mature projects in the region, one of which (Swan Lake) is likely to be available in 2026, which matches Avista timeline of capacity need. Furthermore, Swan Lake and Goldendale are in the process of refining their cost assumptions and, should Avista issue an RFP, would likely be able to provide update cost figures that may make pumped storage a more attractive option, particularly considering the infeasibility of constructing a new natural gas plant, as explained below.

## II. Swan Lake and Goldendale Request Further Information on Avista’s Modeling Assumptions for Pumped Storage

Swan Lake and Goldendale appreciate that Avista has been forthcoming with a significant amount of data that was used to develop the Draft IRP. That said, Swan Lake and Goldendale request Avista provide some additional information and data on the modeling assumptions used for the various pumped storage resources considered in the Draft IRP. Specifically, Swan Lake and Goldendale request further information regarding: (1) the “state of charge” assumed by Avista in order to develop its capacity values for pumped storage, as seen in Table 9.12; (2) what duration Avista assumed for the useful life of a pumped storage project; and (3) whether Avista’s analysis of pumped storage considered the Swan Lake project specifically, which is expected to be available in 2026 and, therefore, aligns with Avista’s capacity need.

### a. Swan Lake and Goldendale Request Further Information on Avista’s Modeling Assumptions Regarding a Pumped Storage Project’s State of Charge

Swan Lake and Goldendale believe one of the impediments to long-duration pumped storage performing even better in Avista’s Draft IRP is the very low capacity values being assigned to pumped storage resources. For example, Table 9.12 indicates an 8-hour pumped storage project would only contribute 30% to Avista’s peak capacity need, and even a 12-hour project would contribute only 58%.<sup>4</sup> Considering these figures are much lower than Swan Lake and Goldendale would expect, and drastically lower than those used by other utilities in the Pacific Northwest,<sup>5</sup> Swan Lake and Goldendale request that Avista provide further information regarding the assumed “state of charge” for these resources. Swan Lake and Goldendale assume the “state of charge” assumptions are the genesis for these low figures.

If the highest priority for pumped storage is reliability, then Avista would always have the ability to charge it for its longest available durations, eight hours or more. Understanding that Avista will always prioritize reliability over economic optimization, adjustments to the state of charge modeling may be appropriate. Swan Lake and Goldendale believe that Avista’s model may be using a very low state of charge entering into the next operating day for pumped storage (possibly as low as 20% pond fill); however, this planning assumption does not align with the operational

<sup>4</sup> *Id.* at 9-28, Table 9.12.

<sup>5</sup> Swan Lake and Goldendale would also note for the Commission’s benefit that both PacifiCorp and Portland General Electric use capacity contribution figures in the range of 80-95% for pumped storage in their respective IRPs.

realities associated with operating hydro or pumped storage facilities. Operationally, peak load days are fairly predictable, meaning that Avista's operations folks would set up for those days in advance to ensure its hydro (or pumped storage) facilities have sufficient pond fills to cover the expected peak load hours. Furthermore, the pumped hydro facility would not necessarily need to deplete its full reservoir daily to address capacity needs (low frequency of 8-hour reliability events), reducing the total amount of charging required to address all potential loss of load events.

A low capacity contribution value (ELCC) for pumped hydro implies that the facility is energy limited and does not have access to the market or other on-system resources to charge for peak load events. Swan Lake and Goldendale understand that Avista may be concerned about the evolving market for peak import assumptions during the winter, given the emerging regional capacity shortage documented in several NWPCC studies. However, import assumptions during off-peak hours in the winter should be re-visited, given that these would be key hours when long-duration storage would charge for the winter on-peak reliability. Additionally, if not already doing so, Swan Lake and Goldendale recommend that Avista consider optimizing the dispatch of their resources over a wider time window (1-2 weeks). A wider optimization time window in resource adequacy models allow for greater operational flexibility of long duration storage and minimize the need for daily charging and discharging. For the foregoing reasons, at minimum, pumped storage should be treated like a traditional hydro facility with storage capability, which the Draft IRP assigns a 60-100% peak capacity credit.<sup>6</sup>

b. Swan Lake and Goldendale Request Further Information on Avista's Assumed Useful Life for a Pumped Storage Project

Similarly, Swan Lake and Goldendale request that Avista provide further information on the assumptions they used for the expected useful life of a pumped storage project. Swan Lake and Goldendale's experience—which is informed by discussions with pumped storage turbine manufacturers and industry examples throughout the U.S. and abroad—suggests that a pumped storage resource's useful life is, at minimum, 40 years, and more likely will last 50 years or more. Using an appropriate useful life will ensure pumped storage's costs are properly considered over the long time horizon in which a pumped storage resource will continue to reliably operate.

c. Swan Lake and Goldendale Request Further Information on Whether Avista's Pumped Storage Analysis Specifically Considered the Swan Lake Project

Given the statements in the Draft IRP noted above regarding a potential mismatch of timing, Swan Lake and Goldendale request further information from Avista on whether it specifically considered the Swan Lake project. While both Swan Lake and Goldendale are among the most mature and viable pumped storage projects in the region, it appears Avista's analysis assumes Swan Lake will not be available to meet its small 2026 capacity need of 12 MW, nor would Swan Lake be available to meet the much larger need of 301 MW in 2027.<sup>7</sup> However, Swan Lake is expected to achieve commercial operation in late-2026, so Swan Lake and Goldendale are concerned that Avista's

<sup>6</sup> Draft IRP at 9-28, Table 9.12.

<sup>7</sup> See *id.* at 7-3.

analysis is not considering the Swan Lake project, despite it being a viable option that aligns with Avista's capacity needs.

Furthermore, Avista's capacity figures assume Colstrip remains part of its portfolio through 2025; however, this assumption may not be prudent, considering the faster-than-expected push to retire coal plants throughout the region. In a scenario where Colstrip retires earlier than expected—which Swan Lake and Goldendale believe is more likely than not—Avista's capacity need would significantly increase, thereby further supporting Avista's early action on a potential capacity RFP, as further explained in Section IV below.

### **III. The Draft IRP Should Remove New Natural Gas as a Viable Resource Option**

In addition to the CETA requirements that mandate the removal of emitting generation sources from Avista's generation portfolio, Governor Inslee also recently announced legislation that would phase out all natural gas in homes and businesses by 2050.<sup>8</sup> Furthermore, Avista has a stated goal of having a carbon neutral electricity supply by 2027 and having 100 percent clean electricity by 2045.<sup>9</sup>

Given these recent developments, which highlight the unfriendly political environment for natural gas, instead of proposing to construct new natural gas facilities, Avista should focus its efforts on a Preferred Resource Strategy that aligns with both CETA and this evolving political landscape. To the extent Avista believes new natural gas resources are allowable under CETA, Swan Lake and Goldendale request that Avista provide a detailed explanation for why a new gas resource would meet one of the few and limited CETA provisions allowing construction of such resources, particularly including violation of reliability standards and, if violations are possible, whether pumped storage could help alleviate or solve those potential violations. Furthermore, considering the unfriendly political climate for new gas resources and Avista's own commitments to transitioning to a carbon-free future, Swan Lake and Goldendale request that Avista re-run its IRP analysis with a constraint of no new natural gas resources. Doing so would likely result in pumped storage being in the Preferred Resource Strategy, considering the statements noted above.

Swan Lake and Goldendale would also remind Avista and the Commission that, Avista need only look to Portland General's IRP process for evidence of the political realities associated with permitting new gas resources. Specifically, a few years ago, Portland General attempted to expand its Carty Generating Station (referred to as "Carty 2"). When Portland General proposed expanding the capacity of Carty in its IRP process, significant stakeholder opposition immediately arose and effectively killed the gas-fired plant as a potential solution to meet Portland General's future capacity needs. Therefore, Avista should be aware that environmental groups, renewable resource developers, and many stakeholders will likely align to uniformly oppose any new gas facility. As a result, Avista should instead remove new gas as an option from its Draft IRP and re-

<sup>8</sup> See *Washington State Proposes Legislation to Phase Out Natural Gas Utility Service*, S&P Global, Jan. 6, 2021, available at: <https://www.spglobal.com/marketintelligence/en/news-insights/latest-news-headlines/washington-state-proposes-legislation-to-phase-out-natural-gas-utility-service-61819435>.

<sup>9</sup> *Avista Declares Clean Electricity Goal*, April 18, 2019, available at: <https://www.myavista.com/-/media/myavista/content-documents/our-environment/cleanelectricitygoalnewsrelease-pdf.pdf>.



run the analysis to determine a Preferred Resource Strategy that aligns with both CETA and Avista’s own climate goals.

#### **IV. Swan Lake and Goldendale Strongly Support Avista Issuing a Capacity RFP As Soon As Possible**

In the Draft IRP, Avista indicates may release a capacity RFP as early as 2021. Specifically, the Draft IRP states, “To meet the January 1, 2026 capacity shortfall and to validate Avista’s preferred choice of long duration pumped hydro to meet this deficit, Avista may release a capacity RFP as early as 2021. . . Avista is still committed to releasing a capacity RFP subject to the needs of the final 2021 IRP.”<sup>10</sup> Swan Lake and Goldendale strongly support Avista’s plan to release a capacity RFP as soon as possible.

While Swan Lake and Goldendale have highlighted some of their concerns regarding the modeling and assumptions used for pumped storage in these comments, the only accurate way for Avista to fully evaluate potential pumped storage projects—including the various projects’ pricing information, timing for construction, and whether the operating characteristics align with Avista’s needs—is through actual proposals received through an RFP. Without an actual offer submitted through an RFP, Avista will be relying on its own assumptions and expectations regarding the price, timing, and operating characteristics of pumped storage. Furthermore, because pumped storage resources are relatively unfamiliar to many utilities in the Pacific Northwest, these resources are at a disadvantage in the IRP modeling and evaluation process, particularly when compared to other resources with which utilities are more familiar and have better data.

Therefore, Swan Lake and Goldendale overwhelmingly support Avista issuing a capacity RFP as soon as possible to evaluate potential clean-capacity resources to meet its identified capacity needs. Swan Lake and Goldendale request that Avista confirm its intention to do so and, if necessary, the Commission and Commission Staff specifically direct Avista to prepare and issue such an RFP as promptly as possible.

---

<sup>10</sup> Draft IRP at 14-5.

**V. Conclusion**

Swan Lake and Goldendale appreciate the opportunity to provide these comments on the Draft IRP. While Swan Lake and Goldendale are encouraged by some of the statements in the Draft IRP that suggest pumped storage is the preferred resource, Swan Lake and Goldendale believe further work needs to be done on the pumped storage modeling and analysis, as well as to remove natural gas as a viable option for fulfilling Avista's future capacity needs.

If you have any questions, please contact the undersigned.

Sincerely,

/s/ Nathan Sandvig

Nathan Sandvig  
[nathan@ryedevelopment.com](mailto:nathan@ryedevelopment.com)

DRAFT



February 5, 2021

Mark Johnson, Executive Director/Secretary  
 Washington Utilities and Transportation Commission  
 1300 S. Evergreen Park Dr. S.W., P.O. Box 47250  
 Olympia, Washington 98504-7250

Re: Avista 2021 Draft Integrated Resource Plans for Electricity and Natural Gas  
 Dockets UE-200301 (electricity) and UG-190724 (natural gas)

Received  
 Records Management  
 02/08/21 10:24  
 State Of WASH.  
 UTIL. AND TRANSP.  
 COMMISSION

Mr. Johnson;

The NW Energy Coalition (“NWECC” or “Coalition”) appreciates the opportunity to comment on the draft Integrated Resource Plan (“IRP”) submitted by Avista Utilities on January 4<sup>th</sup>, 2021, per the Notice of Opportunity to File Written Comments issued by the Commission on January 5<sup>th</sup>, 2021.

The Coalition is an alliance of more than 100 organizations united around energy efficiency, renewable energy, fish and wildlife preservation and restoration in the Columbia basin, low-income and consumer protections, and informed public involvement in building a clean and affordable energy future.

The Coalition notes Avista’s timely submission of a draft integrated resource plan (IRP) in compliance with the schedule established by the Commission. We hope our comments will be useful in revising the IRP for its final submission. The utilities must soon prepare their first CEIPs under CETA. It is extremely important that the IRP/CEAP be technically correct and thorough, since it “informs” the CEIP. The specific actions the utility plans to undertake as described in the CEIP per 19.405.060(1)(b)(i) and (iii) are intended to be informed and consistent with the IRP. Shortcomings in an IRP/CEAP must not be used as a means to limit the utilities’ attainment of CETA standards in their CEIP. A CEIP based on an insufficient IRP/CEPA analysis that fails to create a path towards meeting the 2030 standards will not be acceptable.

Our comments address both the overall context for planning and specifics issues in the IRP.

### **The standard for integrated resource planning has changed**

Unlike previous planning cycles, CETA unequivocally established standards for 2030 and 2045. The approach to integrated resource planning and resource acquisition planning should have changed accordingly. IRPs are no longer simply analyzing lowest reasonable cost alternatives,

but lowest reasonable cost alternative *pathways that lead to achieving the 2030 and 2045 standards*. That is the analysis needed to provide the data and context for specific targets and actions in the CEIP.

CETA's intent is to transform the electric system - it requires a utility to: (1) eliminate coal fired resources from a utility's allocation of electricity by the end of 2025; (2) achieve cost-effective conservation and efficiency to reduce load; (3) reduce demand as much as possible with demand response actions; and (4) use electricity from renewables and non-emitting generation 1 to serve 80% of the remaining retail load by 2030, and 100% by 2045.

This first round of IRPs under CETA should be clearly focused on how to reach the goals, not how to approximate the standards or to reach a utility's own vision of "carbon neutrality", while ignoring the statutory requirements.

Avista's explanation for the Clean Energy Targets table (CEAP p. 15-4, table 15-2) indicates that may be the case in the CEAP. Avista raises the strawman that "use" of electricity from renewable and non-emitting sources means "minute-by-minute tracking" of electrons. That is not the case. While the rules regarding "use" are still being developed, the language of the statute is clear. As Avista states in the introduction to the CEAP "this Action Plan is subject to change prior to the April 1, 2021 IRP filing date to account for potential renewable resource acquisitions from the 2020 Renewable FRP and as final CETA rules by the Washington Utility and Transportation Commission (WUTC) are issued". An IRP should analyze the various pathways to meet the standards as set out in statute.

For example, using the data from that chart for a quick "back of the envelope" calculation, it appears likely that Avista could meet the 2030 compliance standards for using electricity from renewables and non-emitting to meet the 80% standard. Using the data in WA Clean Energy Targets table 15.2, adjusting the net retail load of 641 aMW in 2030 to 80% amounts to 512.8 aMW. Most of that can be met with the 436 aMW from the renewable resources Avista already owns. The shortfall of 76.8 aMW can be met with a little more than half of the planned 144 aMW from Montana wind. The 20% portion of retail sales, or 128.2 aMW, could be met with various other resources listed on that chart.

### **Key Outcomes for the 2021 Avista IRP**

The Avista 2021 IRP has two high priority tasks:

- First, to set a new direction in electric system planning in accordance with the policy direction and compliance requirements of CETA. Both the policy and compliance aspects are important.
- Second, to address system needs after the conclusion of 222 MW of coal plant service to Avista customers by the end of 2025, as required by CETA, and other system changes, especially the termination of the Lancaster 257 MW natural gas contract in 2026.

Recognizing that the draft IRP takes significant steps in the right direction, NWECA believes additional improvements can be made for both tasks. We address these questions below in two sections focusing on the overall IRP and the 2027 preferred resource portfolio.

While the draft IRP is not fully complete, Avista has presented a clear and detailed analysis, provided work products and responded to stakeholder questions. The preferred portfolio continues to develop energy efficiency and begins to lay out a strategy for acquiring demand response resources, although we believe the targets can be increased and the pace can be accelerated. The treatment of new renewable resources is somewhat more mixed, as described below. Finally, significant improvement is needed for both the cost and capacity value battery and pumped storage.

We also give special commendation to Avista's Energy Equity analysis in chapter 13. This is a strong first step in assessing energy burden and service quality across Avista's Washington service territory, especially for vulnerable populations and highly impacted communities. Avista's work is already setting a standard for utilities across the Northwest. We look forward to further enhancements, including assessment of whether services and programs for customer side resources like energy efficiency, demand response, distributed generation and electric vehicle support are equitably available.

All that said, a significant question still should be addressed. While the draft IRP anticipates retirement of Colstrip coal as early as 2021 and Lancaster gas in 2026, we are concerned about the addition of 211 MW of new gas peaking capacity in 2027 to help address the gap. A new peaker unit of that size would have a capital cost above \$200 million, with additional fixed and variable O&M including fuel cost, and would continue in operation for many years. We believe further analysis will show that there are substantial available and cost-effective clean energy resources that can defer or eliminate this new emitting resource.

### **Cross-Cutting Issues for CETA Policy and Compliance**

#### **A. Natural Gas Resource Risk**

Even if the Avista gas fleet as a whole operates at a lower annual capacity factor over time, continued additions of new gas capacity resources could pose both reliability and cost concerns. Recent episodes including the BC pipeline explosion in October 2018, ongoing restrictions in pipeline delivery and Jackson Prairie storage through the spring of 2019, and more recently maintenance problems on the Williams pipeline through the Columbia Gorge in the fall of 2020, highlight the tenuous situation for gas deliverability.

#### **B. Market Reliance**

We commend Avista for a thorough market analysis (chapter 10) and provide the following observations.

The price and availability risk in the short-term market (primarily the Mid-C trading hub) has been growing in recent years. Underlying recent price disturbance episodes, including very high prices in February-early March 2019 due to exceptionally cold weather and gas delivery constraints, there is an underlying structural change in the Northwest bilateral market with two key drivers.

First, a recent PacifiCorp presentation in an IRP workshop shows that the transaction volume for the Mid-C trading hub has basically fallen in half over the last five years. There is some evidence that much of the decline is the result of transactions moving to the Energy Imbalance Market which is more liquid and has a favorable real-time pricing regime compared to the outmoded high load hour/low load hour Mid-C construct. While EIM energy flows to load in an economically beneficial manner, the EIM cannot assist with day-ahead and operational unit commitment and dispatch.

Second, the retirement of Northwest coal resources and other changes is continuing to diminish market supply relative to demand. This poses increasing price and availability risk going forward.

Two other developments may counter the trend somewhat. For short term capacity, the proposed Northwest Power Pool resource adequacy program could alleviate peak risk both through advance commitments and an operational program. On the energy side, the Enhanced Day Ahead Market expansion of the EIM could move forward, providing much deeper and more liquid market access.

All that said, we conclude that the short-term market is increasingly risky, but we are also confident that enhanced development of clean energy resources can help reduce market exposure.

### C. Social Cost of Greenhouse Gases (SCGHG)

The IRP analysis states “construction and operational greenhouse gas emissions are considered and priced using the SCC”, but that the SCGHG was not applied to market purchases and sales in the PRS as done previously. The reason for the change from previous practice is not clear. The statute at 19.280.030(3)(a) states a utility must incorporate the SCGHG when evaluating and selecting conservation policies, programs and targets; when developing integrated resource plans and clean energy action plans; and when evaluating and selecting intermediate term and long-term resources. The SCGHG is a variable cost used in planning to internalize the costs of emitting CO<sub>2</sub>e. The SCGHG does not function as a tax that is passed through to customers. In the *modeling* process, for both the IRP and CEAP, the SCGHG should be applied to variable costs, dispatch modeling and unspecified or fossil fueled market purchases.

The impact of adding the SCGHG to market purchases is tested in portfolio #19 – SCC on Purchases/Sales Resource Selection (IRP p. 12-29). This results in relatively little impact relative to the PRS portfolio, except to select less solar. That result might well change if hybrid resources, such as solar+battery were assessed, instead of charging storage with market purchases.

Further, the Optimized SCGHG Carbon Future Portfolio shown in Table 12.24 not only improved costs over the PRS, reduced natural gas by 88MW and increased energy efficiency and wind. This option also reduced solar, but probably for the same storage charging reasons as in portfolio #19.

In the final IRP/CEAP Avista should model a portfolio in which the SCGHG is optimized as a variable cost and applied to unspecified and fossil fueled electricity brought in state for customer use. This portfolio should also include hybrid resources, as discussed later.

#### D. Upstream Methane Emissions

An issue linked to the application of SCGHG is the life cycle emissions for gas power plants. As we explained in a submission to the Northwest Power and Conservation Council,<sup>1</sup> recent peer-reviewed research has revised upstream methane emissions factors sharply upward. Because of the current and proposed new addition of natural gas generation, we urge Avista to revisit this issue and adjust the upstream methane emissions factor represented in the Social Cost of Greenhouse Gas analysis.

### **2027 Preferred Resource Portfolio**

With the cessation of coal power supply after 2025 and the expiration of the Lancaster gas contract in 2026, the year 2027 is a useful point for evaluating system need and proposed new resources.

In 2027, the draft IRP indicates a need for 301 MW of capacity. The draft proposes to fill the gap with ongoing energy efficiency, the beginning of a demand response program, 200 MW of Montana wind, a 12 MW upgrade at Kettle Falls, and 211 MW of peaker resources (85 MW for Idaho and 126 MW for Washington/Idaho).

NWEC believes further review is needed on several categories of clean energy resources to see if they can provide additional capacity value and defer or eliminate the need for new peaker resources.

---

<sup>1</sup> NWEC letter to Northwest Power and Conservation Council, June 15, 2020, [https://www.nwccouncil.org/sites/default/files/2020\\_0616\\_2.pdf](https://www.nwccouncil.org/sites/default/files/2020_0616_2.pdf)

## A. Two Types of Capacity Need

The pivotal point to understand about the period after 2026 is that there are basically two types of capacity need. We refer to these as typical and long-duration peak periods.

A typical peak period is that observed in most years, where demand peaks within a range described by the median or “1-in-2” demand forecast.

Once or more per decade, a long-duration peak condition may occur, with extended high daily peaks that may recur for two or more consecutive days, as reflected in a “1-in-10” forecast. In the winter, these conditions may occur during very cold “Arctic express” periods where demand is very high on a sustained level and renewable energy production is low. In such conditions, the entire Northwest will be energy limited, market supply will be very expensive and perhaps restricted, and gas supply from Canadian sources and storage withdrawals may also be constrained.

In the late summer, similar heat wave conditions may occur. The reduced availability of hydro peaking compared to winter stress conditions is an additional factor.

The question we pose is whether a staged approach to capacity need could provide a balanced 2027 resource portfolio that is better aligned with CETA policy guidance while meeting reliability needs cost-effectively.

The first stage involves maximizing the availability of so-called “energy limited” clean flexible resources, including demand response and storage. These are generally considered to provide capacity value of 4 hours duration and should suffice for meeting needs during typical peak periods.

In the second stage, meeting rare long-duration peaks requires supplemental resources. The draft IRP suggests that new peakers can meet these supplemental needs. But once these very expensive and high-emitting new peakers are put into the resource mix, the IRP models will dispatch them not only for very infrequent long duration high peaks, but much more often across the year because they are now “existing” resources. As a result, these new peakers will displace less expensive, non-emitting resources. This creates a lost opportunity for CETA compliant clean energy resources.

Avista should investigate the availability of firm capacity or other term resources to meet infrequent long-duration event needs, for example from regional imports or merchant gas plants. As time goes on, those resources could be replaced with new long-duration storage from sources such as renewable hydrogen, renewable natural gas and pumped storage.

Below, we suggest the additional potential for clean flexible resources including demand response, storage and hybrids to meet typical peaks.



## B. Demand Response

The Conservation Potential Assessment (CPA) includes estimates for the technically available potential of demand response, and the preferred portfolio includes initial steps toward achieving that potential.

The CPA summarizes the technically achievable potential for DR at 90 MW in 2025 (about 5.1% of peak load) and 170 MW in 2045 (almost 10% of peak). NVEC agrees that this is a reasonable magnitude for total potential, but we believe it can be achieved considerably faster.

The preferred portfolio indicates 53 MW of DR in 2027 (3% of peak) in 2027. We believe further assessment will show this amount can be increased.

For example, we estimate about 7 MW per year of technically achievable potential is available from one specific resource – stock turnover and conversion to grid enabled residential electric water heaters, or about 35 MW between now and 2027. In addition, new construction and gas-to-electric conversions could increase the potential. This resource is facilitated by Washington’s incoming requirement for all new electric water heaters to have a CTA-2045 communications interface, providing a common access standard.

It remains to be seen what level of customer participation can be achieved for a grid enabled water heater program, but we anticipate that with effective customer engagement strategies it can be higher than the 50% saturation assumed by Avista and the savings potential of 48.9 MW by 2045 can be increased and significantly accelerated.

For demand response and load management as a whole, it is apparent that program launches can be moved forward considerably. In the Clean Energy Action Plan, Table 15.1 indicates that the first programs will appear in 2024, and the last in 2031. It would make more sense to launch a coordinated set of DR programs earlier so they can scale up rapidly to meet capacity need in 2027 and beyond. Portland General Electric has already succeeded in taking that path, including both coordinated pilot programs and the Smart Grid Testbed. Their new Flexible Load Plan lays out a strategy for moving DR to full maturity in the next 5 years.

**Table 15.1: Demand Response and Load Management Programs**

Program	Washington
Time of Use Rates	3.1 MW (2024)
Variable Peak Pricing	8.9 MW (2024)
Large C&I Program	25.0 MW (2027)
DLC Smart Thermostats	0.6 MW (2031)
Total	37.6 MW (2031 Total)

## C. Storage Cost

NWEC believes that most of the reference resource costs in the draft RFP are in the reasonable range, though we may have different views on specific resources and future cost trajectories.

However, the future costs for batteries and pumped storage simply don't seem reasonable. The values in Figure 9.1 show slight declines in battery costs, and then flat or rising costs through the remainder of the planning horizon. Most other estimates show consistently declining costs through the coming decades, though at varying rates.

**Figure 9.1: Lithium-ion Capital Cost Forecast**

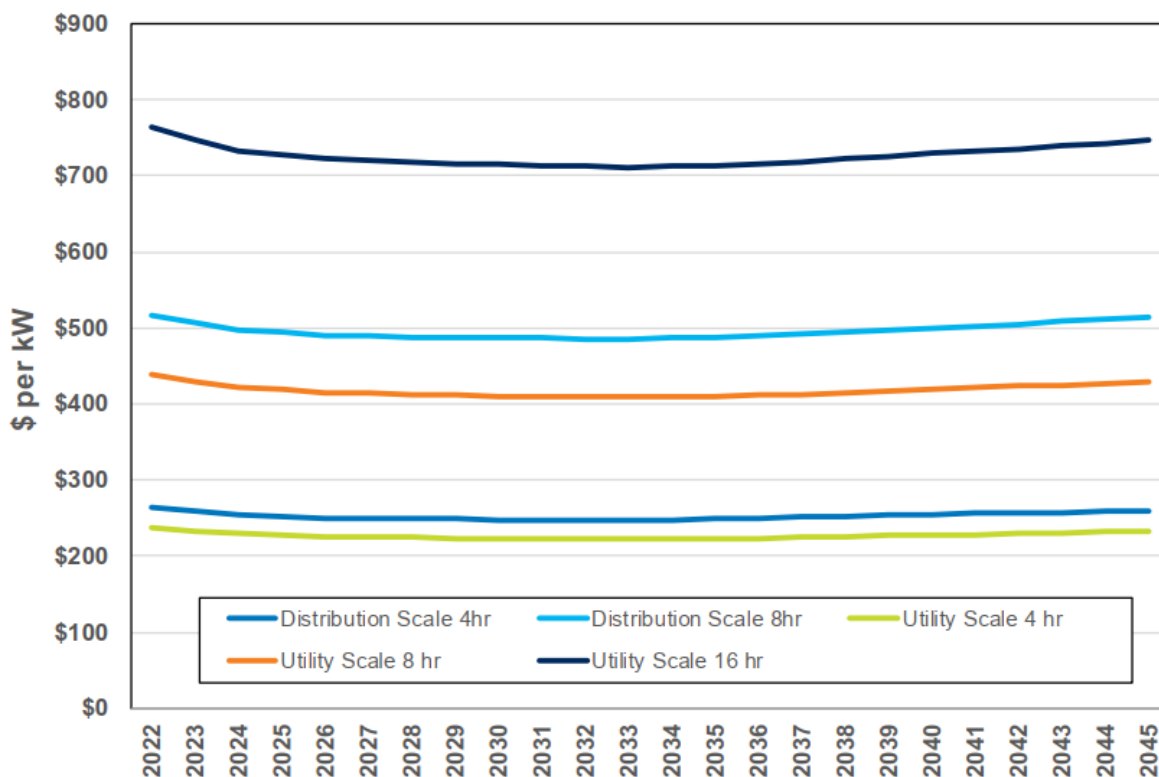

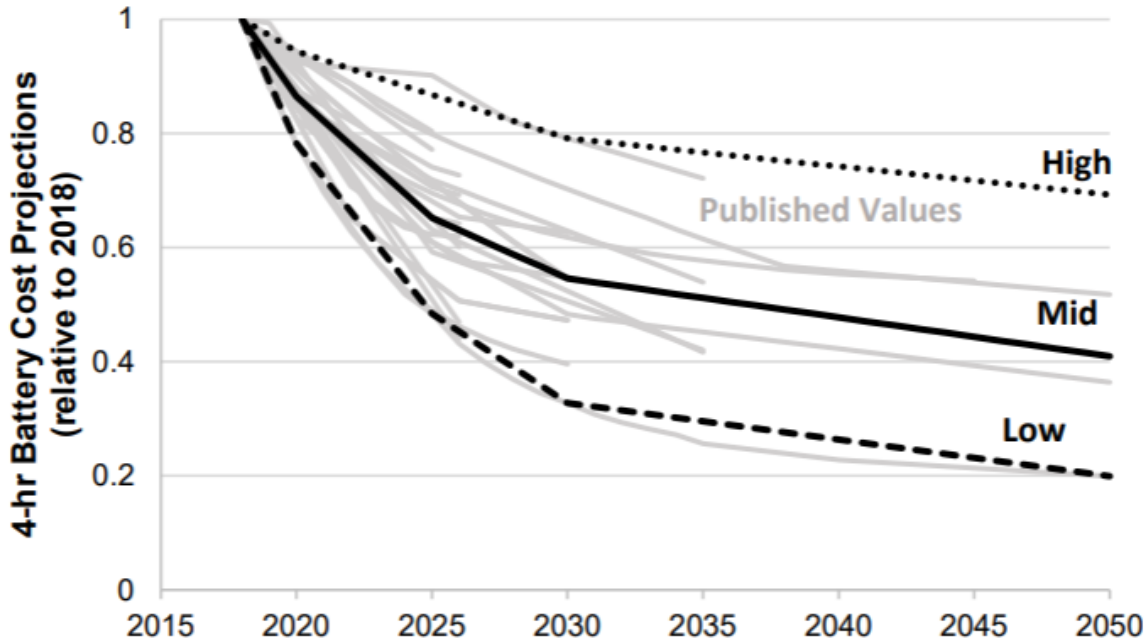

Cost Projections for Utility-Scale Battery Storage, National Renewable Energy Laboratory (2019). NREL/TP-6A20-73222, <https://www.nrel.gov/docs/fy19osti/73222.pdf>

Turning to pumped storage, the draft IRP states:

With the exit of Colstrip and the expiration of the Lancaster PPA in the fall of 2026, the PRS adds 211 MW of natural gas-fired CTs. The 2020 IRP assumed the capacity lost from Colstrip and Lancaster could be met with long duration pumped hydro, but the updated cost and construction schedule information for pumped hydro caused this resource to not be selected in this IRP. This modeling result is consistent with a scenario analysis performed in the 2020 IRP showing natural gas CTs would be required if low cost long-duration pumped hydro was not available by 2026. Avista will continue to follow pumped hydro developments for future consideration.

Draft IRP at 11-5.

Table 9.6, Pumped Hydro Company-Owned Options, provides a summary of costs, but NWECC does not fully understand the presentation and has not been able to pinpoint the underlying data for this conclusion. There are at least two pumped hydro projects with a reasonable chance of commercial operation by 2027, and further specific project assessment would be useful.

#### D. Storage and Hybrid Capacity Value

A notable aspect of the preferred portfolio is the lack of composite (hybrid) resources before 2038, when the first solar+battery resource appears.

The rapid emergence of hybrid resources around the nation and in the Northwest indicates the importance of composite resources to meet both energy and capacity needs. A leading example is PGE's acquisition of a large portion of the NextEra Wheatridge project, an innovative three-way hybrid of wind, solar and storage.

With regard to PacifiCorp's current all-source RFP, it is widely expected that solar+battery hybrids will be selected for half or more of the total acquisition, potentially amounting to more than 2000 MW of solar capacity and over 1000 MW of battery storage.

A recent study by Astrape Consulting for Pacific Gas & Electric, Southern California Edison and San Diego Gas & Electric found a substantial increase in ELCC value for Northwest (BPA Balancing Area) wind hybrid resources. No value for solar hybrids was provided for the Northwest because of insufficient data, but the effect is expected to be similar.

**Table A2. ELCC Values for 2026 (expressed as a percentage of assumed interconnection capability)**

Region	BTM PV	Fixed PV	Tracking PV	Tracking PV Hybrid	Wind	Wind Hybrid
CA-N	1.3%	2.1%	3.4%	100%	17.9%	94%
CA-S	0.6%	1.2%	1.9%	100%	17.8%	95%
AZ APS	N/A	~0.0%	1.9%	97%	30.8%	97%
NM EPE	N/A	~0.0%	1.9%	95%	30.8%	97%
BPA	N/A	N/A	N/A	N/A	32.8%	90%
CAISO	<b>1.0%</b>	<b>1.7%</b>	<b>2.7%</b>	<b>100%</b>	<b>17.9%</b>	<b>94%</b>
<b>Average</b>	<b>1.0%</b>	<b>0.8%</b>	<b>2.3%</b>	<b>98%</b>	<b>26.0%</b>	<b>95%</b>

The values in the Astrape analysis are not directly comparable because they are with reference to California ISO summer peak conditions. That said, the dramatic effect of battery availability to shift energy to peak periods is clear. Yet the draft IRP indicates only a 17% peak credit value for solar plus 4-hour battery resources and 15% for standalone 4-hour storage.

**Table 9.12: Peak Credit**

Resource	Peak Credit (percent)
Northwest solar	2
Northwest wind	5
Montana wind <sup>10</sup> 100-200 MW	35 to 28
Hydro w/ storage	60-100
Hydro run-of-river	31 <sup>11</sup>
Storage 4 hr duration	15
Storage 8 hr duration	30
Storage 12 hr duration	58
Storage 16 hr duration	60
Storage 24 hr duration	65
Storage 40 hr duration	75
Storage 70 hr duration	90
Demand response	60
Solar + 4 hr Storage <sup>12</sup>	17
Solar + 2 hr Storage <sup>13</sup>	12

Whether the renewable resource is Montana wind with batteries or pumped storage shifting energy into the morning and evening peaks, or eastern Washington solar plus batteries shifting mid-day peak solar into late afternoon demand, NWECC views Table 9.12 as likely underestimating peak value. In addition, there is no value listed for wind + storage (either battery or pumped hydro), which is a clearly relevant use case.

As Avista proceeds towards the 2021 capacity RFP, we encourage revisiting this key issue. Hybrid resources could provide a significant capacity benefit and defer the need for new gas peakers, as well as make more effective use of limited available transmission capacity for renewables and provide more operating flexibility.

### **Conclusion**

The Coalition appreciates the work that has gone into the preparation of this draft IRP. We look forward to collaborating on analyzing the changes we have suggested.

Respectfully,

Joni Bosh  
Senior Policy Associate  
NWECC  
[joni@nwenergy.org](mailto:joni@nwenergy.org)

Fred Heutte  
Senior Policy Associate  
NWECC  
[fred@nwenergy.org](mailto:fred@nwenergy.org)

**BEFORE THE WASHINGTON  
UTILITIES AND TRANSPORTATION COMMISSION**

**In the Matter of Avista  
Draft 2021 Electric Integrated Resource  
Plan**

**DOCKET UE-200301**

---

**In the Matter of Avista  
Draft 2021 Natural Gas Integrated  
Resource Plan**

---

**DOCKET UG-190724**

**COMMISSION STAFF COMMENTS REGARDING  
AVISTA CORPORATION d/b/a AVISTA UTILITIES  
DRAFT INTEGRATED RESOURCE PLANS  
SUBMITTED IN COMPLIANCE WITH  
RCWs 19.405, 19.280 and WACs 480-90-238, 480-100-600 through -630  
AND UNDER CONSOLIDATED DOCKETS UE-191023 AND UE-190698,  
Order R-601**

**February 5, 2021**

## Contents

Introduction .....	2
<b>Summary of Staff Assessment</b> .....	2
<b>Gas Transportation Customer Conservation</b> .....	3
<b>Recommendations related to the 2021 Final IRP</b> .....	4
<b>Recommendations for the CEIP and future IRP planning cycles</b> .....	5
Staff Assessment of 2021 Draft Integrated Resource Plan by Focus Area.....	7
<b>Clean Energy Action Plan</b> .....	7
<b>Climate change</b> .....	10
<b>Load Forecasting</b> .....	12
<b>Upstream Emissions &amp; SCGHG</b> .....	13
<b>Sub-hourly Modeling Capabilities</b> .....	14
<b>Demand-Side Resources and Distributed Energy Assessments</b> .....	15
<b>Distribution Planning and Non-Wires Alternatives</b> .....	18
<b>Nonenergy Impacts</b> .....	19
<b>Customer Benefit Provisions in CETA</b> .....	20
<b>Resource Adequacy Assessment and Uncertainty Analysis</b> .....	21
<b>State Allocation of Resource Need</b> .....	23
<b>Electrification Scenarios</b> .....	23
<b>Public Participation</b> .....	24
<b>Data Disclosure</b> .....	25
<b>Natural Gas Design Day (Planning Standard)</b> .....	26
<b>Natural Gas CPA and Conservation Targets</b> .....	26
<b>Renewable Natural Gas (RNG)</b> .....	27

## Appendices

Appendix 1: Rules and statutes overview

## Introduction

On January 4, 2021, Avista Corporation d/b/a Avista Utilities (Avista or company) submitted its draft Integrated Resource Plan (Draft IRP) in Dockets UE-200301 and UG-190724. The Washington Utilities and Transportation Commission (UTC or commission) posted a Notice of Opportunity to File Written Comments and Notice of Recessed Open Meeting. Written comments are due by February 5, 2021, and the recessed open meeting is scheduled for 9:30 a.m. on Tuesday, February 23, 2021. The company will file its completed 2021 IRP (Final IRP) with the Commission by April 1, 2021.<sup>1</sup>

Commission staff (Staff) prepared these comments to assess whether Avista's Draft IRP satisfies the rules and statutes governing the company's IRP filings, highlight areas of strength in the Draft IRP, suggest opportunities for improvement in the final IRP, and make recommendations for the clean energy implementation plan and the next integrated resource planning cycle. In developing these comments, Staff consulted with Jeremy Twitchell from Pacific Northwest National Laboratory.

### *Summary of Staff Assessment*

**Electric:** Avista's public process, data transparency, and analysis of results were executed well. While the company's handling of equity and the customer benefit mandate is understandably underdeveloped, Staff is comfortable with the trajectory and looks forward to working closely with the company. However, the company's Draft IRP can be improved in terms of clarity and thoroughness in certain areas. Staff has concerns that the utility is undervaluing flexible resources such as storage, solar, and distributed energy resources (DERs), because of incomplete analysis of the impact of climate change, lack of sub-hourly modeling, the lack of a comprehensive DER resource assessment, and limited application of nonenergy impacts.

Avista plans to meet or exceed the clean energy standard by acquiring 375 MW of clean energy resources by 2031. As shown in Figure 1, the preferred portfolio (or preferred resource strategy as labeled in the Draft IRP) has Avista economically exiting Colstrip in 2021 and over 300 MW of natural gas plants by 2040. The preferred resource strategy includes the addition of new natural gas peakers for system reliability in 2027 and 2036.

**Natural gas:** Overall, Staff is satisfied with Avista's analysis and resulting preferred portfolio for natural gas with the data available to-date and through Advisory Group participation. Without inclusion of the appendices with the Draft IRP, there are details missing Staff has not been able to fully analyze. Given that no new, large resource acquisitions are anticipated for natural gas this document is heavily focused on the electric IRP. Recommendations for the IRP process for natural gas often overlap with electric; Staff provides targeted comments on separate areas specific to natural gas.

---

<sup>1</sup> See Docket UE-180738, Order 02 (Nov. 7, 2019) and Docket UG-190724, Order 01 (Feb. 6, 2020).



Resource Type	Year	State	Capability (MW)
Colstrip	2021	WA/ID	(222)
Montana wind	2023	WA	100
Montana wind	2024	WA	100
Lancaster	2026	WA/ID	(257)
Kettle Falls upgrade	2026	WA/ID	12
Natural Gas Peaker	2027	ID	85
Natural Gas Peaker	2027	WA/ID	126
Montana wind	2028	WA	100
NW Hydro Slice	2031	WA	75
Rathdrum CT Upgrade	2035	WA/ID	5
Northeast	2035	WA/ID	(54)
Natural Gas Peaker	2036	WA/ID	87
Solar w/ storage (4 hours)	2038	WA/ID	100
4-hr Storage for Solar	2038	WA/ID	50
Boulder Park	2040	WA/ID	(25)
Natural Gas Peaker	2041	ID	36
Montana wind	2041	WA	100
Solar w/ storage (4 hours)	2042-2043	WA	239
4-hr Storage for Solar	2042-2043	WA	119
Liquid Air Storage	2044	WA	12
Liquid Air Storage	2045	ID	10
Solar w/ storage (4 hours)	2045	WA	149
4-hr Storage for Solar	2045	WA	75
Supply-side resource net total (MW)			1,024
Supply-side resource total additions (MW)			1,581
Demand Response 2045 capability (MW)			71
Cumulative energy efficiency (aMW)			121
Cumulative summer peak savings (MW)			111
Cumulative winter peak savings (MW)			116

**Figure 1: 2021 Preferred Resource Strategy<sup>2</sup>**

### ***Gas Transportation Customer Conservation***

One tangential issue Staff brings to the Commission's attention is the requirement in RCW 80.28.380 for the utilities to identify and acquire all conservation measures that are available and cost-effective. While it has been the practice of the utilities to exclude gas transportation customers from participating in their conservation programs, Staff struggles to find an exclusion for gas transportation customers in the statutory language of RCW 80.28.380. Staff notes that the IRP does not address the provision of gas for these customers; they acquire their own gas. Thus, the CPA typically included in a gas IRP has not historically included any assessment of conservation for these customers. There is, however, a linkage between the conservation potential for these very large gas transportation customers and the expected distribution system improvements the company includes in the IRP. Acquiring that conservation should reduce the need for distribution system improvements.

<sup>2</sup> Avista Draft 2021 Electric Integrated Resource Plan, Docket UE-200301, pp. 1-5, Table 1.1, (Avista Draft Electric IRP) (Jan. 4, 2020).

Staff expects the issue of conservation from gas transportation customers and its inclusion or exclusion from the target can be addressed on a case-by-case basis with each company during the approval of each company's CPA and target.

***Recommendations related to the 2021 Final IRP***

- **Clean Energy Action Plan**
  - Add a table to the CEAP that includes year-over-year capacity of all planned resources, including demand response.
  - Include planned Appendix G with details of about planned transmission and distribution improvements.
- **Climate change**
  - Provide discussion regarding the implications of possibly moving from a winter peaking utility to a dual or summer peaking utility.
- **Load Forecasting**
  - Clarify the date in which its economic inputs were finalized.
  - Discuss any adjustments to the forecast made in response to the ongoing pandemic.
  - Clarify the high and low load growth ranges used on page 3-14. For example, how did the company settle on the high and low assumptions for annual service area employment and population growth outlined in table 3.3? Please explain.
  - Discuss the assumptions behind the EV and solar PV forecasts that are inputs into the load forecast.
  - Clarify which of the two climate change forecasts the IRP uses.
- **Upstream Emissions & SCGHG**
  - Include in the narrative description required by WAC 480-100-620(11) a clear articulation of how the company calculated the SCGHG.
  - Discuss assumptions about the SCGHG in market purchases and charging storage resources with market purchases.
  - Explain why 1.0 percent is an appropriate upstream emissions factor for U.S. Rockies natural gas.
- **Sub-hourly Modeling Capabilities**
  - Clarify storage cost assumptions.
- **Customer Benefit Provisions in CETA**
  - Provide a scenario or, at minimum, a narrative regarding possible changes to resource decisions that could increase customer benefit.
  - If available and time permits, incorporate the DOH data in the CIA.
- **Resource Adequacy and Uncertainty**
  - Clarify the company's peak credit methodology, including the definition of "peak" terms.
  - Explain how the company incorporates uncertainty in the RA assessment.
- **Public Participation**
  - Provide an IRP update based on any recent planned resource acquisition.
- **Data Disclosure**

- Ensure appendices include a record of stakeholder feedback and the company's response.
- Provide context for the data files provided on the company's website and submit in the docket.
- **Natural Gas Design Day (Planning Standard)**
  - Explain the new design day methodology.
  - Explain why the new design day standard is now the most appropriate one.
- **Renewable Natural Gas**
  - Include details of RNG cost assumptions in the appendices.

***Recommendations for the CEIP and future IRP planning cycles***

- **Climate change**
  - Incorporate a suite of variables, including snowpack, streamflow, and rainfall parameters; meteorological trends; and load risks into the analysis. Staff believes further study is needed.
  - Consider additional resources, such as a climatologist or climate change specialist, to analyze climate impacts over time on Avista's system.
- **Load Forecasting**
  - Conduct a back cast of the load forecasting model, using actual values for their independent variable inputs to their load forecast to assess whether their models have systematic bias.
  - Include a section in the load forecasting chapter that "assess[es] the effect of distributed energy resources on the utility's load," as per WAC 480-100-620(3).
- **Sub-hourly Modeling Capabilities**
  - Develop a workplan to expand sub-hourly modeling and discuss with stakeholders.
  - Expand sub-hourly modeling capability to appropriately evaluate DERs on equal footing with utility-scale renewable and other supply-side resource options.
- **Demand-Side Resources and Distributed Energy Assessment**
  - Treat DERs as generation resource in modeling, not just net from load.
  - Optimize DERs with supply-side resources.
  - Account for rate increases or pricing signals that can move peak demand and change DER uptake.
  - Consider issuing a RFI for DR without prescriptive screens to better understand potential.
  - Take a proactive approach to DR program implementation in the CEIP, accounting for longer lead time of customer sited programs.
  - Ensure programs in the CEIP are scalable.
- **Distribution Planning and Non-Wires Alternatives**
  - Start a public distribution planning process in 2022.
- **Nonenergy Impacts**
  - Identify which nonenergy impacts are required and allowed for resource selection.
  - Include NEIs for all resources, as appropriate.

- Consider how NEIs do and do not overlap with equity requirements.
- Identify where real data collection makes sense and where continued use of proxy is fine.
- **Customer Benefit Provisions in CETA**
  - Incorporate the Department of Health Cumulative Impact Assessment (CIA) into the IRP CIA.
  - Utilize the customer benefit indicators developed through the equity advisory group to design and model a maximum customer benefit scenario.
- **Resource Adequacy and Uncertainty**
  - Incorporate the results of the regional resource adequacy program, as appropriate.
  - Discuss “peak” definitions within the advisory group.
- **State Allocation of Resource Need**
  - Facilitate a discussion between Washington and Idaho stakeholders concerning state allocation of resources.
- **Electrification Scenarios**
  - Consider effects of policy trends towards electrification on both the electric and natural gas systems.
- **Public Participation**
  - Provide additional time to review presentations prior to meetings.
  - Post meeting minutes in a timely manner and allow opportunity for revision.
  - Consider if additional staffing is required to adequately meet new IRP requirements.
- **Data Disclosure**
  - Provide contextual aids alongside data input files.
- **Natural Gas Design Day (Planning Standard)**
  - Explore the feasibility of using projected future weather conditions in its design day methodology, rather than relying exclusively on historic data. The company is conducting a similar analysis for a climate change scenario in its electric IRP.
- **Natural Gas CPA and Conservation Targets**
- **Renewable Natural Gas**
  - Use any up-to-date cost and other data that is available to model potential RNG resources.

## Staff Assessment of 2021 Draft Integrated Resource Plan by Focus Area

### *Clean Energy Action Plan*

To comply with statute and rules, Avista presented a ten-year clean energy action plan that *works towards implementing* the lowest reasonable cost solution, including incorporation of the social cost of greenhouse gas emissions as a cost adder in its analysis.<sup>3</sup> Specifically, each CEAP should:

- meet clean energy transformation standards, including customer benefit provisions<sup>4</sup>;
- be informed by the utility's ten-year cost-effective conservation potential assessment;
- identify the potential cost-effective demand response and load management programs that may be acquired;
- establish a resource adequacy requirement and demonstrate how each resource, including renewable, nonemitting, and DERs, may reasonably be expected to contribute to meeting the utility's resource adequacy requirement;
- identify any need to develop new, or to expand or upgrade existing, bulk transmission and distribution facilities; and
- identify the nature and extent to which the utility intends to rely on an alternative compliance option identified under RCW 19.405.040(1)(b), if appropriate.

Avista's presents its draft CEAP as the lowest reasonable cost plan of acquisitions, given societal cost, clean energy, and reliability requirements.<sup>5</sup> Table 15.2 outlines Avista's CEAP energy-related projected new resources, identifying the year-over-year, resource ramp needed in the next ten years to meet energy needs of both Idaho and Washington<sup>6</sup> customers, including initial "targets" to acquire an **additional 375 MW** by 2031 of new clean energy resources:

- 180 aMW of clean energy by 2031
  - 144 aMW (300 MW) of Montana Wind
  - 31 aMW from renewing a (75 MW) long-term hydro purchase power agreement in 2031
  - 5 aMW from a 12 MW upgrade to the Kettle Falls Generating Station (existing)
- Along with, under median hydro conditions, 41 aMW of clean energy purchases *from* Avista's Idaho customers and 20 aMW of RECs.<sup>7</sup>

---

<sup>3</sup> WAC 480-100-620(12).

<sup>4</sup> WAC 480-100-610.

<sup>5</sup> Avista's plan exceeds goals of Washington's Energy Independence Act (EIA), relying on the Palouse and Rattlesnake Flat Wind contracts, generation from the Kettle Falls biomass facility and upgrades to the Clark Fork and Spokane River hydroelectric developments.

<sup>6</sup> Avista notes its CEAP is specific to Washington's portion of Avista's system needs in compliance with CETA.

<sup>7</sup> Avista notes, depending on the determination of the WUTC's decision regarding compliance with the 100 percent goal, Avista may need additional clean energy and/or RECs if renewable and non-emitting energy must be delivered to customers *instantaneously*. Chapter 12 of the 2021 Draft IRP outlines the cost and energy acquisition impacts of this scenario.

Avista is planning to procure resources capable of meeting *Washington load*. Questions remain regarding whether such resources could be dispatched in a manner to serve Washington demand: Does this clean energy resource acquisition imply clean energy operations? Operationally, how this energy is getting used and whether such “use” meets the spirit and letter of CETA remains a topic of discussion during Washington clean energy legislation implementation.<sup>8</sup>

In the Draft CEAP, Avista signaled preference for renewable projects located in vulnerable population areas to “further develop those economies,” indicating this does not include new generation facilities in Washington except for an upgrade to the Kettle Falls wood-fired facility, which Avista believes is not located in a vulnerable population area.<sup>9</sup>

Avista also provides a narrative and series of commitments related to the customer benefit provisions of CETA. The company plans to form an Equity Advisory Group (EAG) that is responsible to review the indicators and vulnerable populations, asserting the EAG will also help guide the design of the vulnerable population outreach and engagement and be used to distinguish and prioritize additional indicators and solutions needed to develop the upcoming Clean Energy Implementation Plan. Avista's CEAP also includes a discussion of its analytical enhancements to include energy and non-energy benefits, and the company concludes these enhancements *should* benefit vulnerable communities. Staff agree that identifying non-energy benefits is a good first step towards identifying customer benefit indicators and implementing programs in a manner that ensures equitable distribution of energy and non-energy benefits.

Staff notes Avista's projections outlined in this CEAP may change. Avista flagged in its Draft IRP analysis that a future request for proposal (RFP) may identify a lower cost clean resource to meet the first significant reliability shortfall and could yield resources more beneficial than those more broadly identified in the CEAP.

For the draft CEAP, Staff is unable to provide an overarching recommendation due to the extent of Avista's draft submittal, including lack of complete appendices and modeling data for examination. However, Staff offers several observations and suggestions for the Final IRP:

*CEAP Presentation.* The draft CEAP includes Table 15.1 with an outlay of DR programs, from 2024 through 2031, and a narrative, which identifies potential to reduce load by 37.6 MW by 2031, noting a 25 MW large commercial customer program offering *may come to fruition* before the Lancaster PPA ends in 2026. Staff appreciates the company's CEAP presentation in Table 15.2, representing the company's year-over-year resource need in average capacity (aMW), or the average power output of the facility over a given period, percent clean energy target and goal, available resources, including owned and contracted, delineated by resource type and general location (as appropriate), and projected shortfall.

---

<sup>8</sup> See [“Use” discussion docket notice](#) relating to Clean Energy Implementation Plans and Compliance with the Clean Energy Transformation Act, Docket UE-191023 (June 12, 2020).

<sup>9</sup> Avista Draft Electric IRP at 15-5. Note that Avista formats the pages of the IRP with dashes. To avoid confusion, throughout these comments Staff cites a single page as “XX-XX”, and multiple pages in the draft IRP with a “XX-XX to XX-XX” format.

For nameplate capacity presentation (MW), Avista provides Table 1.1 in the IRP, which provides the company's "preferred resource strategy" through the 2045 but lists Demand Response at the bottom of the table with no timing specified, other than "2045 capability."<sup>10</sup> Staff points to the new IRP rules, which define CETA-related *resource need* as:

*any current or projected deficit to reliably meet electricity demands created by changes in demand, changes to system resources, or their operation to comply with state or federal requirements. Such demands or requirements may include, but are not limited to, capacity and associated energy, capacity needed to meet peak demand in any season, fossil-fuel generation retirements, equitable distribution of benefits or reduction of burdens, cost-effective conservation and efficiency resources, demand response, renewable and nonemitting resources.*<sup>11</sup>

For the final CEAP, Staff suggest Avista also include incremental nameplate capacity (MW), or maximum capacity, including in tabular form year-over-year, showing the timing of all planned capacity resources: (1) existing and contracted resources (identified by resource type, location, or potential location); (2) peak import projections; (3) peak capacity needs before demand-side resources (developed from forecast + planning margin); (4) demand-side resources; and (5) peak capacity resource need net demand-side resources.

*CEAP resources.* The evaluation of delivery systems, including transmission expansion is becoming increasingly important because resources are becoming more geographically diverse and shared among utilities.<sup>12</sup> The definition of lowest reasonable cost in the IRP rules includes planned resources and "related delivery system infrastructure," which shows consistency with chapters 19.280, 19.285, and 19.405 RCW. Staff notes Avista's CEAP does not discuss significant transmission or distribution improvements. Instead, the company briefly explains these resources are "likely to be off system or utilize existing transmission assets, not requiring new investment in the next ten years," as shown in Appendix G.<sup>13</sup> Staff looks forward to reviewing Appendix G in the Final IRP, noting details were not provided for stakeholder review as part of the Draft IRP.

### **Recommendations for the Final IRP:**

- Add a table to the CEAP that includes year-over-year capacity of all planned resources, including demand response.

---

<sup>10</sup> Staff notes in Table 1, demand response and load management programs are essentially footnoted, not included in the resource year-over-year ramp in the table or represented side-by-side with other resource type, contracts, or other plant acquisitions.

<sup>11</sup> WAC 480-100-605.

<sup>12</sup> Juan Pablo Carvallo et al., [Implications of a regional resource adequacy program on utility integrated resource planning - Study for the Western United States](#), Energy Analysis and Environmental Impacts Division, Lawrence Berkeley National Laboratory, p. 15, Table 3.5 (November 2020).

<sup>13</sup> Avista Draft Electric IRP at 15-4.

- Include planned Appendix G with details about planned transmission and distribution improvements.

### *Climate change*

Staff is concerned Avista's modeling of climate change in this IRP is not comprehensive. Avista considered historical weather trends during load forecasting and ran a climate change scenario. Still, the possible risks of climate change on resource adequacy and optimal resource portfolio deserve a more complete and nuanced approach in the future.

Avista's expected case load forecast incorporated historical trends that show HDD gradually declining and CDD gradually increasing. The company *contemplated* using two different data sets of trending HDD and CDD forecasts, one using Avista-specific data and the other using Northwest Power and Conservation Council (NWPPCC) state-level data. Both forecasts indicate that Avista's summer peak will grow faster than the winter peak, with the average summer peak eventually higher than the average winter peak.<sup>14</sup> However, the NWPPCC trended forecast shows the summer peak increasing faster, where the winter peak is growing slower than Avista's trended forecast.

Recent regional climate change analysis in the Northwest shows, "anticipated increases in temperature will alter the pattern of electricity use, where higher temperatures and more precipitation tend to result in more rain and less snow during the winter months, thus reducing the snow pack and subsequent summer flow."<sup>15</sup> Importantly, Avista's forecast shows the high end summer peak (95 percent confidence level) is never higher than the high end winter peak, while the NWPPCC forecast shows the high end summer peak is expected to be higher than the winter peak around 2040.<sup>16</sup>

This analysis demonstrates to Staff there is a strong potential that climate change will likely move Avista from a winter peaking utility to a dual or summer peaking utility in the near future.

Avista is incrementally moving in the right direction in the 2021 IRP with respect to incorporating the effects of temperature changes over time; but overall, Avista's climate change analysis as fairly minimal. The company modeled only one *climate shift scenario* that deterministically examined impacts to hydro production and reduced gas plant maximum capabilities expected to result from climate change. Avista used NWPPCC data that estimated additional hydro generation in the winter and less in the spring and summer. To simulate climate change impacts to load, Avista, with assistance from the Pacific Northwest Utility Conference Committee, used NWPPCC data to create linear trends in load by month. This scenario results in marginally lower wholesale electricity prices and slightly lower emissions due to increased hydro production.

<sup>14</sup> Avista Draft Electric IRP at 3-23, Table 3.7

<sup>15</sup> Northwest Power and Conservation Council, "Update on Climate Scenario Selection for the 2021 Power Plan". Available at [https://www.nwcouncil.org/sites/default/files/2020\\_04\\_p2.pdf](https://www.nwcouncil.org/sites/default/files/2020_04_p2.pdf).

<sup>16</sup> Avista Draft Electric IRP at 3-24 to 3-25, Figures 3.20 and 3.21.



Avista refers to the NWPCC assessment of climate change impacts in its preliminary resource adequacy assessment presented in December 2020. The company expresses concerns with the limited inputs used to derive the potential climate adjusted load and hydro conditions but does agree that there are great regional resource adequacy risks in this area.<sup>17</sup> Staff agrees and encourages Avista to use more rigor in its analysis exploring the effects of climate change on their system.

Further, to adequately account for the effect of climate change, Avista could consider acquiring additional expertise regarding temperature impacts over time on Avista’s system, especially considering the company’s hydro-reliance position, as shown in Figure 2. Staff suggests the company take a closer look at the methods peer utilities are taking. For example, Seattle City Light included a study on “Climate Change Effects on Supply and Demand,” as an appendix to its IRP, dedicating resources to assess the IRP climate sensitivity on the utility’s load-resource balance, including reduced snowpack, earlier melt, higher winter inflows, and lower summer inflows. This additional information provided insights into climate change scenarios’ effects to potentially change the *expected base portfolio* for supply and demand.<sup>18</sup>

**Winter Peak Capability**

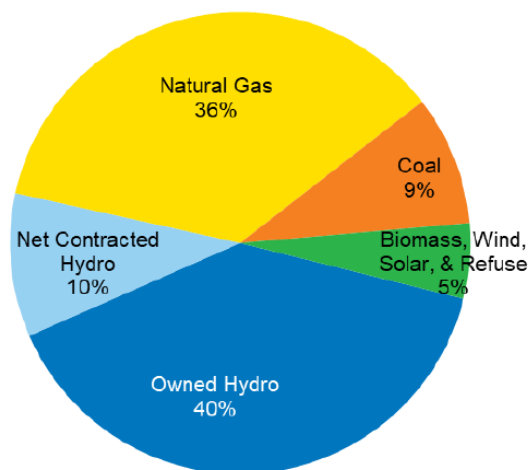

**Annual Energy Capability**

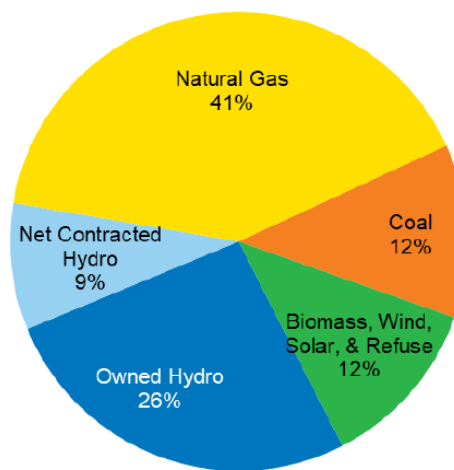

**Figure 2: 2020 Avista Capability and Energy Fuel Mix<sup>19</sup>**

<sup>17</sup> Avista Draft 2021 Electric IRP at 7-12.

<sup>18</sup> [NWPC presentation on Climate Change and the 2021 Power Plan Workshop](#); Seattle City Light (May 1, 2019). Also see *Seattle City Light 2016 IRP*, [Appendix 12](#).

<sup>19</sup> Avista Draft 2021 Electric IRP at 4-1, Figure 4.1.

## Recommendation

### For **Final IRP**:

- Provide discussion regarding the implications of possibly moving from a winter peaking utility to a dual or summer peaking utility.

### For **next IRP**:

- Incorporate a suite of variables, including snowpack, streamflow, and rainfall parameters; meteorological trends; and load risks into the analysis. Staff believes further study is needed.
- Consider additional resources, such as a climatologist or climate change specialist, to analyze climate impacts over time on Avista's system.

## *Load Forecasting*

In addition to the climate change-related recommendations above, Staff finds that the load forecast section could use some clarification in the Final IRP. Avista conducted base, high-, and low-load growth forecasts, as did its peer utilities. Comparisons to the other two utilities are difficult because the Draft IRP narrative lacks sufficient detail, including how Avista derived the input assumptions for the high- and low-load growth scenarios.

One area where the Avista Draft IRP falls short of its peer utilities is discussing whether and how the ongoing COVID-19 pandemic has impacted its load forecast. For example, the company does not specify when its economic inputs into the forecast were finalized, or whether it has made any adjustments to the forecast to account for observed load impacts from the state's stay-at-home orders. The state's (and the nation's) economy has been severely impacted since the pandemic's onset in early 2020. For Staff to appropriately evaluate Avista's forecast, especially considering the new 10-year Clean Energy Action Plan requirements which create mid-term requirements within the company's 2045 planning horizon, more information is needed.

## Recommendation

### In the **Final IRP**:

- Clarify the date in which its economic inputs were finalized.
- Discuss any adjustments to the forecast made in response to the ongoing pandemic.
- Clarify the high and low load growth ranges used on page 3-14. For example, how did the company settle on the high and low assumptions for annual service area employment and population growth outlined in table 3.3? Please explain.
- Discuss the assumptions behind the EV and solar PV forecasts that are inputs into the load forecast.
- Clarify which of the two climate change forecasts the IRP uses.

### In the **next IRP**:

- Conduct a back cast of its load forecasting model, using actual values for their

independent variable inputs to their load forecast to assess whether their models have systematic bias.

- Include a section in its load forecasting chapter that “assess[es] the effect of distributed energy resources on the utility’s load,” as per WAC 480-100-620(3).

### ***Upstream Emissions & SCGHG***

For both the electric and natural gas IRP, Avista includes the social cost of greenhouse gases (SCGHG) as a cost adder in its portfolio optimization of resource options, including upstream emissions from natural gas. Avista describes the application of the SCGHG in several places in the IRP. However, Staff finds the Draft IRP lacks a separate detailed methodology as to how the company applies this cost adder in its electric portfolio optimization and preferred portfolio selection. Staff expects Avista to provide a narrative illustrating step-by-step how the SCGHG cost adder is applied throughout its modeling logic, including associated cost calculations, with the Final IRP.<sup>20</sup>

For upstream methane emissions, Avista uses a global warming potential (GWP) factor that was calculated based on the International Panel on Climate Change’s Assessment Report 5 (IPCC AR5), which Staff prefers over older analyses. Avista uses the upstream methane leakage factor of 0.77 percent for Canadian natural gas, and uses 1.0 percent for the U.S. Rockies natural gas factor. Given that this U.S. Rockies natural gas emissions factor is significantly lower than any of the factors analyzed by the NWPCC in its analysis of upstream natural gas emissions, Staff recommends the Final IRP explain why the factor is appropriate.

In the expected case, Avista did not apply the SCGHG for market transactions but did include a scenario to test the effect of applying SCGHG to the annual average emissions rates of net market purchases. Including this value on market emissions led to additional procurement of wind and less storage and solar. This is likely due to the assumption that the energy used to charge storage resources comes from market purchases. Staff recommends additional narrative describing how Avista selected these assumptions regarding market purchases.

During the advisory group process, the company was responsive to Staff’s request to use the annual *incremental* emissions rate instead of the annual *average* emissions rate when assuming a value for SCGHG reduction for energy efficiency. Avista performed a sensitivity to understand how this assumption changed the selection of energy efficiency. The company found that using the average rate savings are 12 percent lower by 2045 (10 aMW less) than when using the incremental rate.

Due to the uncertainty during rule development, Avista developed and performed three different scenarios to help inform the cost of CETA mandates:

- Baseline 1 incorporates the SCGHG but does not include the clean energy standards,
- Baseline 2 achieves the clean energy standards in CETA without using the SCGHG,
- Baseline 3 excludes both the clean energy standards and the SCGHG.

---

<sup>20</sup> WAC 480-100-620(11).

By varying the baseline assumptions and modeling the SCGHG in several ways, Avista provided useful insights into the effect of legislation. However, the Draft IRP provided insufficient narrative describing how the company included SCGHG in the scenarios and the preferred portfolio. Staff recommends a separate narrative that focuses on the different methods Avista used to model the SCGHG in addition to the individual explanations throughout the document.

### **Recommendation:**

In its **Final IRP**, Avista should:

- Include in the narrative description required by WAC 480-100-620(11) with a clear articulation of how the company calculated the SCGHG.
- Discuss assumptions about the SCGHG in market purchases and charging storage resources with market purchases.
- Explain why 1.0 percent is an appropriate upstream emissions factor for U.S. Rockies natural gas.

### ***Sub-hourly Modeling Capabilities***

To fully capture the value of flexible resources such as storage or demand response, IRP models need to have enough granularity to capture intra-hour variables. Modeling sub-hourly dispatch can readily integrate resources offering more granular grid services into portfolio development. For storage resources, it is unclear what is included in the company's cost assumptions and Staff expects these details to be included in the Final IRP.

Staff is concerned about Avista's current ability to optimize all the resources needed for a reliable one hundred percent clean system. With increasing renewable energy on the grid Avista will be challenged to match generation and load. The current paradigm of planning to a peak in winter when the wind isn't blowing must be realigned to recognize that the utility must also plan to a summer peak with an intra-hour weather anomaly. Staff looks forward to updates from Avista regarding its sub-hourly modeling functionality in its ADSS software for the next IRP.<sup>21</sup>

Avista must expand its sub-hourly modeling capability to appropriately evaluate DERs on equal footing with utility-scale renewable and more traditional fossil resource options. Avista could also transition to a LTCE optimization platform that endogenously considers the sub-hourly benefits of DERs. Alternatively, the company can apply cost credits to better characterize the sub-hourly grid services DERs provide, which in turn may increase the likelihood Avista's preferred resource portfolio solution would include these resource options. As discussed within the *Demand-Side Resources and Distributed Energy Assessments* section of these Staff comments, Avista should not assume future IRPs that handle distributed generation simply as a load forecast decrement will be CETA compliant.

---

<sup>21</sup> Avista Draft Electric IRP at 14-6.

## Recommendation

In the **Final IRP**:

- Clarify storage cost assumptions.

Prior to the **next IRP**:

- Develop a workplan to expand sub-hourly modeling and discuss with stakeholders.
- Expand sub-hourly modeling capability to appropriately evaluate DERs on equal footing with utility-scale renewable and other supply-side resource options.

### *Demand-Side Resources and Distributed Energy Assessments*

Energy efficiency, demand response (DR), and other distributed energy resources (DERs) are essential to a clean energy system that adequately serves and benefits all customers. Avista has made a reasonable attempt to value acquisition of energy efficiency and demand response in the Draft IRP but has not sufficiently analyzed other DERs. Avista, like PSE and PacifiCorp, performed potential assessments for EE and DR but only used a forecast of EV and PV adoption.

The modeling of DER is a major weakness in the Draft IRP. Electric vehicle charging and net-metered generation are accounted for in the load forecast, but DERs, except for EE and DR, are not otherwise valued as potential resources. Avista signaled plans to further integrate DERs in the 2025 IRP.<sup>22</sup> This is discussed further in the *Distribution Planning and Non-Wires Alternatives* section below.

### Energy efficiency

CETA has not made any notable changes to the methods used to model energy efficiency (EE). Avista once again retained AEG to perform the conservation potential assessment (CPA) for both the electric and gas IRP. The draft IRP and associated data provide sufficient information to calculate the ten-year, four-year, and two-year cost-effective conservation potential under both CETA and the EIA. The pro-rata share of the ten-year potential is 101,566 MWh.<sup>23</sup> Avista used an iterative process to identify the cost-effective EE to be removed from the load forecast.

Figure 3 below shows the avoided cost of EE for energy and capacity with components broken out. Over the planning horizon the levelized price of EE is projected to be 3.5 cents per kWh.

---

<sup>22</sup> Avista Draft Electric IRP at 2-11 and 14-8.

<sup>23</sup> *Id.* at 5-8.

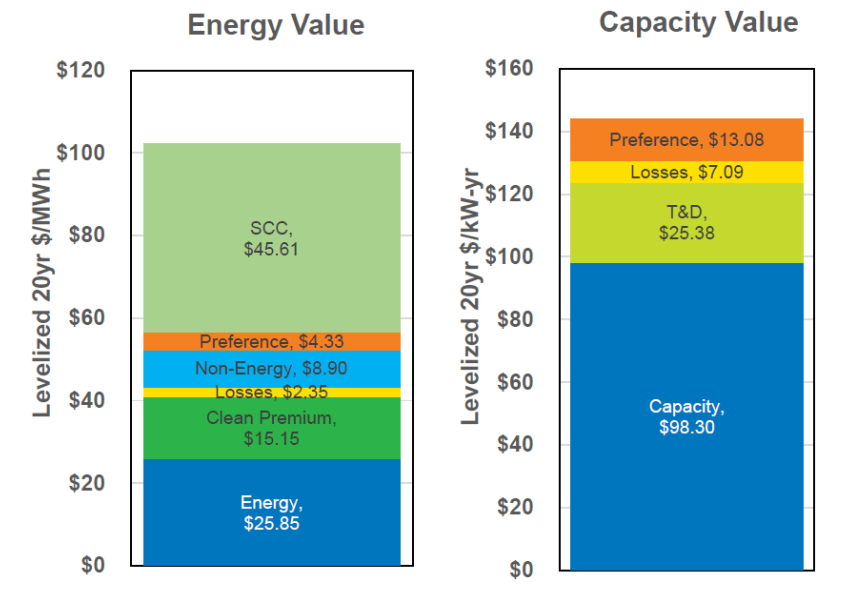

**Figure 3:** Washington Energy Efficiency Avoided Cost<sup>24</sup>

### Demand response

To identify all cost-effective demand response as required by CETA, Avista hired AEG to perform a demand response potential assessment (DRPA) like the CPA for conservation and similar to the DRPA performed in the last IRP.<sup>25</sup> The DRPA includes sixteen residential and commercial programs, and Avista added Large Industrial Curtailment potential outside of the DRPA.<sup>26</sup> The programs include both controllable DR and rate design programs. Where automated metering infrastructure (AMI) is an enabling technology, Avista assumes AMI deployment will be complete in Washington in 2022 (in Idaho the company assumes full deployment in 2024).

DR is treated consistently among the Washington IOUs, including peak reduction as the primary use case of demand response. The amount of reliable capacity contribution from DR should vary by program type, number of events, and by length of event. PSE and Avista each appropriately evaluated sixteen potential demand response programs, including direct load control and pricing options. However, the utilities did not vary assumptions around the *number* and *length of events*, potentially underestimating the potential that a different program design might provide a better fit with the utility system needs. The amount of peak capacity credit given to DR for Avista was 60 percent of a gas-fired combustion turbine.

<sup>24</sup> Avista Draft Electric IRP at 5-14, Figure 5.7.

<sup>25</sup> WAC 480-100-610(4)(a)

<sup>26</sup> Potential assessments assume average market penetration and savings over sizeable populations. Large industrial potentials in Avista's service territory are more appropriately treated individually than on an average basis.

In line with the NWPCC methodology for 2021, the utilities assumed that energy efficiency takes place prior to demand response. In general, Staff agrees with this assumption. However, the specifics of each company's approach lacked the nuance needed to appropriately capture the potential for EE and DR programs to enhance or interfere with each other. Staff acknowledges that this is a complicated task but anticipates efforts to model the interaction effects will be enhanced by utility efforts to integrate EE and DR program efforts during implementation.

In recent years, utility modelling of demand response potential has received negative critiques from stakeholders. With the new mandate to pursue all cost-effective demand response, Staff expected the utilities to refine the modeling of this resource. Unfortunately, this round of IRPs has not made notable improvements over the last round. While Avista and AEG provided ample opportunity for public involvement around the achievable potential for DR, costs for DR were not made available during these meetings, thus not vetted by the advisory group.

Staff has significant concerns regarding the treatment of grid enabled water heaters. Washington has established that electric storage water heaters sold in the state that are manufactured after January 1, 2021, must include a demand response communications port.<sup>27</sup> Turnover of the state's electric water heater stock will take some time but will steadily increase the potential of this resource without additional equipment being required at customer premises. This technology allows frequent load curtailment requests by the utility while ensuring a large supply of hot water remains available to the customer.<sup>28</sup> While each utility included this technology in the potential assessments, no utility provided sufficient discussion of potential program costs and assumptions with the advisory group. Staff requests Avista give this technology additional consideration. Given the large size of a potential program and the current inexperience of northwest utilities with demand response, it is likely costs are overestimated and reliability is underestimated.

## Recommendation

### In the Final IRP:

- Provide the conservation potential assessment model and underlying data.
- Provide the demand response potential model and underlying data.

### In the next IRP:

- Treat DERs as generation resource in modeling, not just net from load.
- Optimize DERs with supply-side resources.
- Account for rate increases or pricing signals that can move peak demand and change DER uptake.
- Consider issuing a RFI for DR without prescriptive screens to better understand potential.

### In the CEIP:

---

<sup>27</sup> RCW 19.260.080

<sup>28</sup> See Bonneville Power Administration, [CTA-2045 Water Heater Demonstration Report](#), (Nov. 9, 2018).

- Take a proactive approach to DR program implementation, accounting for longer lead time of customer-sited programs.
- Ensure programs are scalable.

### ***Distribution Planning and Non-Wires Alternatives***

The IRP rules require the utility to include assessments of a variety of distributed energy resources and the effect of distributed energy resources on the utility's load and operations.<sup>29</sup> Further, the commission strongly encourages utilities to engage in a distributed energy resource planning process as described in RCW 19.280.100. If the utility elects to use a distributed energy resource planning process, the IRP should include a summary of these results.

In the Draft IRP, Avista provides a narrative of its distribution planning efforts, explaining how the company continually evaluates its distribution system for reliability and level of service requirements, including voltage and power quality, for current and future loads. However, Avista did not identify any projects meeting the criteria for an economic non-wire alternative in the Draft IRP. The company contends its near-term distribution projects require capacity *increases* and duration requirements due to load growth exceeding the distributed energy resources (DERs) capability.<sup>30</sup>

Although distribution systems will vary from one utility to another based on the unique characteristics of each system, Staff points to Puget Sound Energy's Draft IRP, which illuminates the capacity value of such resource additions and illustrates the nexus between distribution system and integrated resource planning. For example, PSE includes a line item of distribution system planning incremental nameplate capacity for non-wires alternatives, beginning in 2022 and growing to 118 MW total in the outer years of the plan.<sup>31</sup> Staff supports Avista's continued efforts to continue to study new technologies and grow its situational awareness of other utilities' actions in this space.<sup>32</sup>

Staff suggests Avista continue to engage Staff and keep stakeholders updated on their commitment in the Draft IRP to *start a public distribution planning process in 2022* to identify and plan for future distribution needs. This will allow the company to better anticipate future impacts under CETA and:

- analyze interdependencies among customer-sited energy and capacity resources;
- reduce, defer, or eliminate unnecessary and costly transmission and distribution capital expenditures;
- identify and quantify customer values that are not represented in volumetric electricity rates and maximize system benefits for all retail electric customers; and

<sup>29</sup> WAC 480-100-620(3) Distributed energy resources.

<sup>30</sup> Avista Draft Electric IRP at 8-9.

<sup>31</sup> Puget Sound Energy Draft 2021 IRP, Docket UE-200304, pp. 1-4, Figure 1-4 ("DSP Non-Wire Alternatives").

<sup>32</sup> Avista describes its distribution system as consisting of approximately 350 feeders covering 30,000 square miles, ranging in length from three to 73 miles.



- identify opportunities for improving access to transformative technologies for low-income and other underrepresented customer populations.<sup>33</sup>

## Recommendation

### In 2022:

- Start a public distribution planning process.

### *Nonenergy Impacts*

As described in the appendix to this document, CETA has emphasized the consideration of nonenergy costs and benefits of resources in system planning. In the past, Staff has pushed utilities to account for nonenergy impacts (NEIs) such as the expected emissions of greenhouse gases and particulate matter with quantified health risks.<sup>34</sup> Avista's treatment of nonenergy costs and benefits in this IRP has gone further than any past effort, in large part because of the requirement to include the social cost of carbon.

To address other NEIs connected to public interest objectives such as public health, energy security, environmental benefits, costs, and risks, all three electric IOUs relied on a proxy method using data from the Environmental Protection Agency (EPA).<sup>35</sup> The EPA data includes NEI values generally applicable to all energy efficiency and renewable energy in the Pacific Northwest. Avista analyzed this data to align with its service territory, landing on a benefit value of \$8.90 per MWh. The company then applied this benefit uniformly to energy efficiency measures to approximate unquantified NEIs.

While all utilities started with the EPA data, Avista's proxy benefit value is approximately one half what PSE used and one third of what Pacific Power plans to use in the 2021 IRPs.<sup>36</sup> Staff acknowledges that none of these proxy values accurately capture the value of NEIs, but we appreciate each utility acknowledging that the nonenergy benefits of EE are, on the whole, greater than zero. Prior to the next IRP, Staff expects significant work with utilities and stakeholders to identify which NEIs should be valued, what values can be adequately quantified, and when the use of proxy values is most appropriate.

The primary limitation to the approach Avista took to account for NEIs in the IRP is only applying NEIs (outside of the SCGHG) to energy efficiency. NEIs exist for *all resources* but most have traditionally only been included when evaluating demand-side resources, as the proximity of these resources to customers naturally increases impacts.

---

<sup>33</sup> RCW 19.280.100.

<sup>34</sup> *Staff Comments on 2018-2019 Biennial Conservation Plans*, Dockets UE-171087, UE-171091, and UE-171092, p. 8-9 (Dec. 1, 2017)

<sup>35</sup> Environmental Protection Agency, [Public Health Benefits per kWh of Energy Efficiency and Renewable Energy in the United States: A Technical Report](#), (July 2019).

<sup>36</sup> PSE used a proxy value of \$0.02 per kWh (\$20.00 per MWh), Pacific Power used \$28.70 per MWh, Avista used \$8.90 per MWh.

## Recommendation

### In the next IRP:

- Identify which nonenergy impacts are required and allowed for resource selection.
- Include NEIs for all resources, as appropriate.
- Consider how NEIs do and do not overlap with equity requirements.
- Identify where real data collection makes sense and where continued use of proxy is fine.

### *Customer Benefit Provisions in CETA*

In the Draft IRP, Avista did not perform a maximum customer benefit scenario or sensitivity as required by the new rule.<sup>37</sup> Staff understands that this work dramatically departs from the traditional planning done in the IRP and including it in the Draft IRP may not have been feasible. Staff encourages Avista to make best efforts to model a scenario that would maximize customer benefits in the Final IRP. Given that the maximum customer benefit scenario is a new requirement that will be improved upon and clarified over time, Staff requests the company develop a narrative describing Avista's current interpretation of the rule and proposed next steps regarding intent to model the scenario.

Avista completed commendable work by developing a preliminary methodology for geographically identifying highly impacted communities and vulnerable populations. Avista identified two census tracts as qualifying highly impacted communities. To identify vulnerable populations, the company used the Environmental Health Disparities Map maintained by the Department of Health (DOH) to score areas based on pollution burdens and population characteristics. The company acknowledges that this is an ongoing process that is currently missing several important inputs.

For the Draft IRP, no utility was able to incorporate the Cumulative Impact Assessment (CIA) prepared by DOH, which was expected by the end of 2020.<sup>38</sup> DOH's work on this has been delayed and may not be available for inclusion in the Final IRP. The baseline analysis Avista performed in this IRP identified where there are significant differences in energy use, energy cost, reliability, resiliency, and higher densities of power plant emissions. Avista will need to change its methods to incorporate the DOH data into the next IRP, but Staff is satisfied with the progress to date.

Plans for an equity advisory group (EAG) are well underway at Avista.<sup>39</sup> The company is conducting outreach and carefully considering how to successfully engage marginalized and hard to reach populations. The EAG is separate from the IRP advisory group and will identify

---

<sup>37</sup> WAC 480-100-620(10)(c).

<sup>38</sup> RCW 19.405.140.

<sup>39</sup> WAC 480-100-655(2).

vulnerable populations and develop customer benefit indicators that will be incorporated into the CEIP planning and the next IRP. Staff look forward to Avista growing its current robust low-income programs to serve other highly impacted communities and vulnerable populations.

## **Recommendation**

### **In the Final IRP:**

- Provide a maximum customer benefit scenario and a narrative regarding Avista's current interpretation of the rule and next steps for improvement.
- If available and time permits, incorporate the DOH data in the CIA.

### **Before the next IRP:**

- Create the Equity Advisory Group by May 1, 2021, to provide useful and timely input for the planning cycle. Staff understands that Avista has already begun organizing this group and commends the company approach.
- Incorporate the DOH CIA into the IRP CIA.
- Utilize the customer benefit indicators developed through the equity advisory group to design and model a maximum customer benefit scenario.

### ***Resource Adequacy Assessment and Uncertainty Analysis***

As required by CETA, Avista must determine “resource adequacy metrics for the resource plan,” and identify “an appropriate resource adequacy requirement and measurement metric consistent with prudent utility practice.”<sup>40</sup> The IRP uses Avista's Reliability Assessment Model (ARAM) to test the current resource portfolio's reliability metrics and the contribution of each resource. Continuing from previous IRPs, Avista retains a 5 percent LOLP metric to ensure future system reliability.

In Table 11.5, Avista also shows resource adequacy analysis related to three other reliability metrics, including Loss of Load Hours (LOLH), Loss of Load Expectation (LOLE), and Expected Unserved Energy (EUE). The company currently targets a 16 percent planning margin to meet winter peaks, and 7 percent for summer peaks. This is in addition to meeting operating reserves and regulation requirements.

Avista begins its resource adequacy analysis narrative with a discussion of regional coordination, signaling that it is participating in the development of a potential regional resource adequacy program. The company estimates participation in a resource adequacy program will reduce its needs for new capacity by up to 70 MW in 2031 based on the current draft program design, where these savings will potentially allow the utility to require lower future resource acquisition if the program is developed and implemented.

Avista's draft IRP analysis shows a capacity need of 83 MW of natural gas-fired capacity for Washington customers by 2026, replacing the Lancaster Power Purchase Agreement (PPA), to maintain reliability targets for Washington customers during peak load hours. The company

---

<sup>40</sup> RCW 19.280.030(1)(g) and (i).

assumes 330 MW of market availability for the 2021 IRP, compared to 250 MW in the 2017/2020 IRPs. Avista also indicates that a future RFP may identify a lower cost clean resource to meet this reliability shortfall, but the current IRP modeling results selected a gas-fired resource in 2026.

The analysis of the contribution to RA by storage, DR, and variable energy resources is of particular interest to Staff in the first post-CETA IRP review. For the Final IRP, and into next IRP cycle, Staff suggest Avista include more information about how the company treats, or plans to treat, uncertainty in RA modeling within the IRP, including the following elements of its RA assessment:

#### Resource ELCC Analysis

For its (effective load carrying capability) ELCC analysis, Avista assigned peak credits to renewable and storage resources depending on resource ability to meet peak loads using its ARAM model. The company's ELCC calculations should be a measurement of that resource's ability to produce energy when the company is most likely to experience electricity shortfall, showing how that resource uniquely contributes to reliability requirements.

Avista appears to translate its "peak savings" for demand response into a peak credit that differs depending on duration. Specifically, Staff requests more description about how Avista derived the Peak Credit shown in Table 9.12. For energy storage, when an 8-hour resource only gets a 30 percent credit and a 70-hour resource only gets to 90 percent, Staff questions how the utility uniquely defines *peak* and *peak-related* demand terms.<sup>41</sup> Staff requests additional narrative related to the company's methodology related to Peak Credit, including how Avista specifically defines the terms "peak" and "peak-related" in the Final IRP.

#### Incorporation of uncertainty into RA assessment

Avista indicates "resource analysis identifies a natural gas CT to replace resource deficits if *pumped hydro* is not a feasible resource to meet the 2026 shortfall. Avista will conduct *transmission* and air permitting studies to prepare for this contingency. Avista expects this process to take at least two years."<sup>42</sup> Relatedly, in the Draft IRP narrative for resource adequacy, risk, and uncertainty analyses, it is not clear how the company accounts for *renewable contribution, storage efficiency, or construction*.<sup>43</sup> For example, construction risks could include delays for new assets, other future considerations for resource maintenance, plant upgrades, or transmission expansion uncertainties. Staff request additional narrative how the company incorporates uncertainty in the RA assessment in the Draft IRP, or if the company plans to address these elements in the next IRP cycle.

---

<sup>41</sup> See Natalie Mims Frick et al., [Peak Demand Impacts From Electricity Efficiency Programs Report](#), Energy Analysis and Environmental Impacts Division, Lawrence Berkeley National Laboratory, Appendix B, Table B-2 (Nov. 2019).

<sup>42</sup> Avista Draft Electric IRP at 14-5.

<sup>43</sup> See Juan Pablo Carvallo et al., [Implications of a regional resource adequacy program on utility integrated resource planning - Study for the Western United States](#), Energy Analysis and Environmental Impacts Division, Lawrence Berkeley National Laboratory, p.17, Table 3.5 (Nov. 2020).

## **Recommendation**

### **In the Final IRP:**

- Clarify the company's peak credit methodology, including the definition of "peak" terms.
- Explain how the company incorporates uncertainty in the RA assessment in the Draft IRP, or if the company plans to address these elements in the next IRP cycle.

### **In the next IRP:**

- Incorporate the results of the regional resource adequacy program, as appropriate.
- Discuss "peak" definitions within the advisory group.

### ***State Allocation of Resource Need***

Historically, Avista's allocation of planned electric system resources between states has been determined using the Production-Transportation ratio, which is approximately 65 percent Washington and 35 percent Idaho. As the two states' policy objectives diverge, capacity and energy needs result from different drivers. In the Draft IRP, Avista has done an admirable job attempting to assign resource needs between one hundred percent Washington, one hundred percent Idaho, and a combined system need. Soon, both state commissions will need to grapple with complicated cost recovery allocation.

Avista faces difficult questions related to future rate recovery resulting from long-term resource planning in two states for one utility system: Idaho customers will not want to pay increased rates that may result from CETA and Washington customers will not want to pay for potentially stranded assets from new gas resources. Staff encourages the company to bring stakeholders together for an in-depth discussion and analysis prior to any formal filing. Ultimately interstate cost allocation must be adjudicated, but Staff believes a collaborative process is worth pursuing.

## **Recommendation**

### **Before the next IRP:**

- Facilitate a discussion between Washington and Idaho stakeholders concerning state allocation of resources.

### ***Electrification Scenarios***

In the electric IRP Avista performed three separate scenarios considering the effects that electrification of space and water heat in Washington could have on the portfolio. Avista states that the IRP is not the best vehicle to conduct these studies and recommends a separate regional study. While Staff does not disagree about the usefulness of a regional or statewide study, the company should continue to consider local policy trends towards electrification in both the electric and natural gas IRPs.

## Recommendation

### In future IRPs:

- Consider effects of policy trends towards electrification on both the electric and natural gas systems.

### *Public Participation*

Avista demonstrated a robust public participation process during this IRP. They began by seeking input on a draft work plan and once filed, stayed true to the plan. Avista originally scheduled five technical advisory group meetings. When the scheduled meetings could not cover all the material with the depth the company and advisory group members wanted, Avista added additional webinars and a workshop. Avista provided Staff and the advisory group meaningful opportunities to discuss complex resource planning processes, data assumptions, and other interest topics throughout the IRP planning process. Avista's IRP advisory group is open to all members of the public who wish to participate.

Avista's IRP Team is exceptionally responsive to members of the advisory group, taking input under consideration and taking time to explain complex issues to ensure members were comfortable with their understanding. Deadlines on comments and requests were clear but not rigid. Further, the company provided draft presentations before meetings and followed-up with a final version that contained any last-minute changes or corrections.

Staff recommends more time to review presentations before IRP advisory group meetings, which is crucial for utilities to receive meaningful feedback during the meetings, especially considering Avista's IRP meetings now cover both gas and electric IRP topics. The company should provide advisory group members meeting minutes and follow-up documentation promptly, allowing members an opportunity to suggest revisions or clarifications as necessary. In the future, the company may need to expand its core IRP team to include additional administrative support, especially considering the new customer benefit provisions.

The company filed its Draft IRP on January 4, 2021, mostly complete, except for appendices. Staff notes the lack of appendices is mostly balanced by the excellent data access and availability of Avista staff to stakeholders. Staff also highlights the company's outstanding approach to transparent data access in the *Data Disclosure* section of this document.

In 2020, Avista put out a request for proposals (RFP) for renewable resources. **The RFP process is in its final stages, and there is a possibility that the company will finalize the acquisition of a resource before filing the Final IRP.** To the degree possible, Avista should update the Final IRP with any known resource. If an acquisition occurs soon after the Final IRP is filed, Staff recommends the company file, at minimum, an update to the preferred resource strategy and clean energy action plan so it can develop its CEIP based on the best available information.

Overall, Avista's public participation process is comprehensive and facilitates trust and transparency in the IRP development process. Staff provides recommendations to improve its

public participation process for the next IRP cycle, particularly related to the new documentation and administrative requirements outlined in the rule.<sup>44</sup>

## Recommendation

### In the **Final IRP**:

- Provide an update based on any recently completed resource acquisition.

### In the **next IRP**:

- Provide additional time to review presentations prior to meetings.
- Post meeting minutes in a timely manner and allow opportunity for revision.
- Consider if additional staffing is required to adequately meet new IRP requirements.

## *Data Disclosure*

Avista appears to have best satisfied the data disclosure objectives Staff have highlighted for this first CETA-compliant 2021 IRP cycle of the three Washington electric investor-owned utilities. Overall, the company seems to have provided the data stakeholders requested during the 2021 planning process on time.

Staff notes the *record of stakeholder comments and company responses* is one of the appendices not included in the draft.<sup>45</sup> Unlike peer utilities, Avista's IRP website does not contain an ongoing record of stakeholder comments, data requests, and questions received and addressed by the company.<sup>46</sup> Staff understands that Avista plans to provide this information in the Final IRP but suggests a contemporaneous documentation strategy.<sup>47</sup>

Avista made many data input files available in native format to facilitate stakeholder review of data underlying the company's planning decisions. Staff applauds Avista's commitment to make data and models accessible to stakeholders by posting them to the company's website and providing a webinar dedicated to understanding the PRiSM long-term capacity expansion model.

To further increase accessibility and transparency, the company should provide contextual aids and organize its Final IRP deliverable by including a master table of contents, readme files, and categorically grouping related data.

## Recommendation

### In the **Final IRP**:

- Ensure appendices include a record of stakeholder feedback and the company's

---

<sup>44</sup> WAC 480-100-620, -625, and -630.

<sup>45</sup> Appendix C of Avista's Draft Electric IRP serves as the placeholder for public participation comments. However, the company has not filed any appendices with its draft deliverable.

<sup>46</sup> PacifiCorp's [2021 IRP stakeholder feedback website](#) posts stakeholder feedback forms and company responses to said forms, when available. [Avista's IRP website](#) does not appear to include similar postings.

<sup>47</sup> [WAC 480-100-620](#)(17).

response.

- Provide context for the data files provided on the company's website and submit data files in the docket.

In the **next IRP**:

- Provide contextual aids alongside data input files.

### ***Natural Gas Design Day (Planning Standard)***

Avista's peak day planning standard for natural gas is new to this IRP. In previous plans, the company had used a coldest-on-record standard and has changed to a 99 percent probability of experiencing an extremely cold temperature in each of its service areas. The data underlying Avista's new design day calculation indicates a warming trend in parts of its service territory, but it is still based on historic data, not projections of future temperatures.

Staff requests Avista include a future climate change sensitivity similar to that provided by PSE in its next natural gas IRP and provide more explanation around the new design day methodology, including why this new standard is the appropriate choice. Staff believes a few extra sentences explaining how it combines temperatures "with a 99% probability of a weather occurrence" would make the methodology clearer. In its explanation, Avista should provide additional narrative around Table 2.4 and Figures 2.4 through 2.8 to further describe the trends they depict. On the surface, it seems counterintuitive, for instance, that the new design day methodology has Medford's planning standard significantly warmer than the previous methodology did, while Klamath Falls' peak day has gotten slightly colder, even though the two cities are not that far apart.

### **Recommendation**

In the **Final IRP**:

- Explain the new design day methodology, providing a more detailed narrative.
- Further explain why the new design day standard is now the most appropriate one.

In **future IRPs**:

- Explore the feasibility of using projected future weather conditions in its design day methodology, rather than relying exclusively on historic data. The company is conducting a similar analysis for a climate change scenario in its electric IRP.

### ***Natural Gas CPA and Conservation Targets***

Avista once again retained AEG to perform the potential assessment for both the electric and gas IRP in Washington and Idaho. (Avista uses the Energy Trust of Oregon to conduct its Oregon CPA.) The continuity in CPA contractors allowed Avista to make very few minor changes to the CPA methodology. AEG estimated that Avista's achievable economic conservation potential for its Washington territory is 3.6 million dekatherms by 2040.

Staff has no suggested changes concerning natural gas CPA and conservation targets *at this time*. It is important to note that Staff will be further analyzing the details of the CPA, including



avoided costs, as part of the CPA approval process described in Appendix 1 to these comments.

***Renewable Natural Gas (RNG)***

The Draft IRP discusses RNG at length, including state and regional policy considerations, internal steps the company has been taking to prepare for an RNG program, gas quality specifications, and options to build or buy projects. Avista acknowledges that its cost-effectiveness evaluation methodology for RNG is a work in progress. A voluntary RNG program is currently in development. Staff look forward to reviewing detailed assumptions of RNG in the Final IRP.

**Recommendation:**

**In the Final IRP:**

- Include details of RNG cost assumptions in the appendices.

**In future IRPs:**

- Use any up-to-date cost data that is available to model potential RNG resources.

## Appendix 1

### Introduction

The passage of the Clean Energy Transformation Act (CETA, E2SSB 5116) in 2019 introduced many critical changes to the ways in which electric utilities conduct their integrated resource planning (IRP) processes. CETA also created a separate, new planning requirement called the clean energy implementation plan (CEIP). The new legislation directed the Commission to issue rules related to IRPs, which occurred midway through the previous IRP 2019 planning cycle. Faced with the likelihood the 2019 IRPs may not be fully CETA-compliant, Staff petitioned, and the Commission ordered, the 2019 IRPs be considered IRP progress reports.<sup>1</sup> The Utilities and Transportation Commission (Commission) initiated rulemakings<sup>2</sup> in January 2020 to develop rules that would implement the new law. The IRP and CEIP rules were finalized on December 28, 2020.<sup>3</sup>

The new rules require IRPs to be submitted on January 1, 2021, and on January 1 every four years thereafter.<sup>4</sup> However, given the changes to the IRP process required by CETA, the Commission ordered each electric utility (Puget Sound Energy [PSE], Avista Corporation [Avista], and PacifiCorp) to submit draft 2021 IRPs by January 4, 2021, with the final versions by April 1, 2021.<sup>5</sup>

All three utilities filed their draft IRPs on January 4, 2021. Both Avista and PSE filed joint electric and gas IRPs. On January 5, 2021, the Commission issued a notice of opportunity for comment from interested parties in the IRP dockets for these three companies by February 5, 2021.<sup>6</sup> The notices also announced recessed open meeting dates and times where the companies will present their draft plans and respond to questions from the Commission and interested stakeholders. The recessed open meeting dates are:

- PacifiCorp: Monday, February 22, 9:30 a.m.
- Avista: Tuesday, February 23, 9:30 a.m.
- PSE: Friday, February 26, 10:30 a.m.

---

<sup>1</sup> PacifiCorp, Docket UE-180259, [Order 03](#), ¶¶ 24-25; Puget Sound Energy, Dockets UE-180607 & UG-180608, [Order 02](#), ¶ 15 (Puget Sound Energy); Avista, Docket UE-180738, [Order 02](#), ¶ 15.

<sup>2</sup> Dockets [UE-191023](#) & [UE-190698 \(Consolidated\)](#), implementing the Clean Energy Transformation Act codified as RCW 19.405 and changes to RCW 19.280 - Electric Utility Resource Plans.

<sup>3</sup> *In re Adopting Rules Relating to Clean Energy Implementation Plans and Compliance with the Clean Energy Transformation Act and Amending or Adopting rules relating to WAC 480-100-238, Relating to Integrated Resource Planning*, Dockets UE-191023 & UE-109698 (*Consolidated*), [General Order 601](#), pp. 58-59, ¶ 168 (CETA Rulemaking Order) (Dec. 28, 2020).

<sup>4</sup> WAC [480-100-625](#)(1).

<sup>5</sup> See *supra* n.1.

<sup>6</sup> *Notice of Opportunity to File Written Comments*, Avista, Dockets UE-200301 and UG-190724, and UE-200420; Puget Sound Energy, UE-200304 and UG-200305; and PacifiCorp, Docket UE-200420 (Jan. 5, 2021).

This appendix is organized by subject area as they appear in the Commission's rules and describes the statute and rule requirements that govern the IRP process for both electric and natural gas IRPs. The main body of Staff's comments (to which the current document serves as an appendix) is also organized by subject area, and discusses three things:

- How each IRP meets (or does not meet) the requirements laid out in this appendix;
- Whether each utility's IRP modeling is consistent with its peers; and
- What changes Staff recommends to enable acknowledgment of the 2021 final IRP and Clean Energy Action Plan (CEAP), support the development of the Clean Energy Implementation Plan (CEIP), or in each company's next IRP.

## Overview of Electric IRP Statute and Rule Requirements by Topic

### *Public Participation*

The Commission's new rules facilitate more opportunities for deeper, cross-topical conversations between interested persons and utilities on a variety of IRP issues, such as equity, to implement CETA directives.<sup>7</sup> Staff highlights two of these public engagement components: participation and involvement of the IRP advisory group, and the two-step draft IRP and final IRP submittal, which will eventually help inform the shape and style of a CEIP.<sup>8</sup>

First, to develop an effective IRP, CEAP, two-year progress report, and CEIP, the utility must demonstrate and document how it considered input from its advisory group, including scenarios and sensitivities the utility used.<sup>9</sup> Throughout the IRP planning processes, it is incumbent upon each utility to provide staff, the advisory group, and the public meaningful opportunities to engage and discuss complex resource planning processes, data assumptions, and other topics such as upstream emissions and the SCGHG emissions used in IRP modeling analyses.

Second, utilities are now required to submit a draft IRP, which provides stakeholders, the media, and the public a meaningful *first glimpse* into the utility's thinking around energy and capacity resource planning in the post Clean Energy Transformation Act world, before the utility files its final IRP four months later.<sup>10</sup> Presenting a draft plan for complex energy and capacity planning is not new. In fact, requiring a mostly complete draft to be filed prior to the issuance of a final document is common practice. For example, the Northwest Power and Conservation Council's (NWPCC or Council) power plan development process includes a two-stage process of issuing a draft plan, taking public comment, conducting the appropriate analysis to respond to public comment, and issuing a final plan.<sup>11</sup>

Due to the ongoing COVID-19 public health crisis, the 2021 IRP public participation process

<sup>7</sup> WAC [480-100-620](#); -625; and -630.

<sup>8</sup> WAC [480-100-625](#); WAC [480-100-630](#); CETA Rulemaking Order at ¶ 137.

<sup>9</sup> WAC [480-100-625](#); -630; and -655.

<sup>10</sup> WAC [480-100-625](#)(3).

<sup>11</sup> CETA Rulemaking Order at ¶ 166.

cycle looked very different as compared with previous IRP cycles. Staff is acutely aware the first post-CETA IRP cycle was decidedly more difficult for all involved, with most advisory group meetings held virtually via webinar. Plus, the utility faced unprecedented CETA modeling and timing challenges. Staff comments highlight specific areas of success in the public engagement arena and potential areas of improvement for future IRP cycles.

### *Data Disclosure*

To comply with CETA, electric utilities should address three primary data disclosure themes during the 2021 IRP cycle. First, companies should provide the information that stakeholders request during the planning process in a timely manner or provide clear justification why the request cannot be met.<sup>12</sup> This circulation of information in the development and reporting of IRPs should primarily occur during the advisory group process.<sup>13</sup> Adherence to this principle is important as it will align utility planning with the overarching ethos of CETA – one of accessibility, transparency, responsiveness, and clarity.

Second, to maximize transparency, the electric utilities must file with the Commission all data input files in native format as appendices to the draft IRPs.<sup>14</sup> The Commission, Commission Staff, Public Counsel, and other parties with a substantial interest in a company's plan must be able to understand a utility's decisions. Companies disclosing such data in native format facilitates parties independently determining if those actions were in the public interest and represent the lowest reasonable cost option.<sup>15</sup>

Finally, the data a utility provides during the IRP planning process should be easily accessible.<sup>16</sup> Release of such information should be more than large data dumps, whose sheer size can overwhelm the recipients thus reducing the likelihood questions get answered. Instead, companies should tailor the data provided to the requestor's specific query.<sup>17</sup> While utilities can still designate relevant data confidential in keeping with the Commission's rules,<sup>18</sup> Staff's expectation that accessible information is readily shared amongst stakeholders fosters meaningful and inclusive public engagement throughout the IRP advisory group process.

### *Load Forecasting and Climate Change Impacts*

One of the most critical steps in the IRP analyses involves the assessment of how much total energy the utility's customers are expected to consume over a 20-year period (load), including the maximum amount expected to be consumed instantaneously (peak demand). In the IRP, the utility must assess projected economic and population growth for the region. Further, recently updated IRP rules set forth additional requirements in the load forecasting step of the IRP

---

<sup>12</sup> *Id.*, at ¶ 178.

<sup>13</sup> WAC [480-100-630](#)(3).

<sup>14</sup> WAC [480-100-620](#)(14) requires utilities undertake IRP data disclosure actions suggested in RCW [19.280.030](#)(10)(a).

<sup>15</sup> CETA Rulemaking Order at ¶ 173.

<sup>16</sup> WAC [480-100-620](#)(14).

<sup>17</sup> CETA Rulemaking Order at ¶ 178.

<sup>18</sup> WAC [480-07-160](#).

development process. These include requiring the utility to conduct a new assessment of Distributed Energy Resources or DERs, develop climate change scenarios, and other relevant load assessments.<sup>19</sup>

In addition to their existing requirement to pursue all cost-effective, reliable, and feasible energy efficiency, CETA now requires utilities to pursue all “cost-effective, reliable, and feasible” demand response (DR).<sup>20</sup> Thus, utilities must perform forecasts of cost-effective potential of both resources, where these forecasts must in turn inform the load forecast. Second, CETA requires utilities to conduct an overarching DER forecast, “and an assessment of their effect on the utility’s load.” The Commission’s rules adopted to implement CETA require such forecasts to include energy efficiency, DR, and energy assistance, as well as other DERs like energy storage, electric vehicles (EVs), and solar photovoltaics (PV).<sup>21</sup>

Finally, risks are changing because of climate change. The recently revised IRP rules require utilities to include *at least one* future climate change scenario, incorporating “load changes resulting from climate change.”<sup>22</sup> As compared to the expected ‘base case’ or ‘do nothing’ portfolio, the utility should also consider load impacts, higher risks of changing river flows, disaster frequency, and temperature effects over time on the utility’s load-resource balance.

### *IRP Modeling*

Modeling is central to a utility’s resource planning because the IRP is essentially a numerical solution for how the company will keep the lights on in the short- and long-term, addressing resource need and balancing supply and demand, given a host of constraints.<sup>23</sup> In determining this IRP solution, the company and stakeholders must examine a range of forecasts and analyses when identifying options for how to meet customer demand, compare these options, and ultimately decide what resources to build or acquire.<sup>24</sup> The 2021 IRPs are the utilities’ first roadmaps for realizing the transformative change required by CETA as these plans couple modeling with the supporting narrative required to explain companies’ decisions to a wide stakeholder audience.

Utilities must develop and validate their planning models with additional rigor since electric IOUs’ 2021 preferred portfolios will establish the baseline for achieving CETA’s coal elimination, GHG neutral, and clean electricity targets over the next 25 years.<sup>25</sup> To comply with CETA directives and adaptively manage modeling methodologies, utilities must determine how best to incorporate the social cost of greenhouse gases (SCGHG) into their analytics, properly integrate distributed energy resource (DER) assessments into resource planning, and undertake more sophisticated scenario and sensitivity modeling as compared with previous IRP cycles. These three modeling topics constitute focal points of the 2021 draft IRP staff review.

<sup>19</sup> WAC [480-100-620](#)(3) and (10).

<sup>20</sup> RCW [19.405.040](#)(6)(a); [-.050](#)(3).

<sup>21</sup> WAC [480-100-620](#)(3).

<sup>22</sup> WAC [480-100-620](#)(10)(b).

<sup>23</sup> RCW [19.280.030](#)(1).

<sup>24</sup> WAC [480-100-620](#)(11).

<sup>25</sup> RCW [19.405.030](#)(1); [-.040](#)(1); [-.050](#)(1).

As required by statute and rule, utilities must incorporate SCGHG as a cost adder when evaluating and selecting conservation and resource options. Within their IRP narrative companies should evaluate the robustness of their analytical approaches and describe how the IRP solution incorporates the SCGHG cost adder throughout the modeling stages. Appropriately handling SCGHG within IRP analyses is likely the most important modeling consideration for utilities during the 2021 cycle as this adder applies across the range of resource strategies considered.<sup>26</sup> Modeling SCGHG also serves as an insightful linkage for comparing how Washington’s three IOUs are pricing new CETA requirements into resource selection.

Reflective of CETA, both statute and accompanying rule continue to require the lowest reasonable cost (LRC) solution,<sup>27</sup> but are now more prescriptive when it comes to the types of resources, especially clean alternatives, and analyses that must be considered when planning for future targets. Utilities must now consider a wide range of DER options and undertake quantitative methods (e.g., forecasts of demand response and other demand side management) to determine the impact such efforts will have on utility planning.<sup>28</sup> Utilities should appropriately incorporate DER potential into portfolio development. Staff’s goal is to ensure appropriate utility valuation of resources like demand response (DR) and energy efficiency (EE), which is crucial to meet CETA standards and implement specific targets identified in the CEIP.

Additionally, utilities’ portfolio development must quantify the impact and risk associated with crosscutting concerns like ensuring resource adequacy and equitably distributing customer benefits and costs.<sup>29</sup> Companies need to develop a CETA “counter factual” scenario that identifies the alternative LRC portfolio the companies would have implemented if the CETA requirements around greenhouse gas neutrality by 2030 and clean electricity by 2045 were not in effect. Second, companies need to run a climate change scenario that incorporates the best science available to assess climate change impacts, including hydrological conditions, temperature, and load changes.

Finally, utilities are required to run a sensitivity that examines how their 2021 preferred portfolio performs when benefits for all customers are maximized, before balancing other objectives.<sup>30</sup> This analysis seeks to quantify how all customers, including vulnerable populations or highly impacted communities, are benefiting from the transition to clean energy.<sup>31</sup> The analysis should only adjust variables specific to an IOU’s Washington service territory. The intent of this modeling exercise is to maximize the hypothetical benefit utilities’ Washington customers could realize. There is no “right answer” for how to optimize this benefit so utilities should brainstorm what activities or actions are most efficacious. Once determined, companies could “hardcode” given levels of these benefits and subsequently co-optimize other modeling variables. Staff recognize competing constraints may prevent a company’s 2021 IRP from ultimately reflecting these sensitivity attributes. For the 2021 IRP, the primary result of this sensitivity is additional

<sup>26</sup> RCW [19.280.030](#)(3)(a); WAC [480-100-620](#)(11)(j).

<sup>27</sup> RCW [19.280.030](#)(1)(d); WAC [480-100-620](#)(7) and (11)(a).

<sup>28</sup> RCW [19.280.030](#)(1)(h) and (j); WAC [480-100-620](#)(3) and (11)(c).

<sup>29</sup> RCW [19.280.030](#)(1)(g), (i), and (k); WAC [480-100-620](#)(8), (11)(f) and (g).

<sup>30</sup> WAC [480-100-620](#)(10)(a) – (c).

<sup>31</sup> RCW [19.405.040](#)(8).

data and analyses utilities can further refine for their 2022 CEIP and subsequent planning cycles.<sup>32</sup>

### *Nonenergy Impacts*

The IRP statute changes in CETA require the IRP to address the clean energy transformation standards.<sup>33</sup> This results in the need for nonenergy impacts (NEIs) of the utility's energy system and programs to be included in the 2021 IRP more prominently as compared with previous IRP cycles. Historically, NEIs were nearly all associated with energy efficiency programs and measures. Under CETA, NEIs should be included with all resources when applicable.

Utilities are required to account for nonenergy costs and benefits not fully valued elsewhere in an IRP model within distributed energy resource assessments.<sup>34</sup> For example, a CPA should not include a separate value for the SCGHG if that value is appropriately accounted for elsewhere in the selection of energy efficiency. A nonenergy benefit that occurs exclusively or primarily on the demand-side should be included within the CPA (or other DER assessment). Some values of nonenergy impacts are well documented in the region, particularly those vetted by the Regional Technical Forum. However, there are many impacts for which data is currently unavailable, not monetized, attributable to a program instead of a measure, out-of-date, or not applicable to a particular utility service territory. In these instances, Staff finds it appropriate to use proxy data to identify nonenergy costs and benefits.

Finally, nonenergy costs and benefits are required by the new rules to be listed in the avoided costs section of the IRP and identify if they accrue to utility, customers, participants, vulnerable populations, highly impacted communities, or the public.<sup>35</sup>

### *New Customer Benefit Provisions of CETA*

The clean energy transformation standards described in rule address the affirmative mandate to ensure all customers are benefiting from the transition to clean energy, identifying three *separate* components of the customer benefit requirement.<sup>36</sup> Each component should be addressed in the IRP in multiple ways.

Specifically, the rule requires each utility to include an assessment of economic, health, and environmental burdens and benefits in the IRPs.<sup>37</sup> While the cumulative impact analysis (CIA) conducted by the department of health that should inform the assessment was not available in

---

<sup>32</sup> Conservation Energy Planning and Energy Policy staff customer benefit discussion, January 20, 2021.

<sup>33</sup> RCW [19.280.030](#)(1) requires an IRP to address the “. . . implementing [of] RCW 19.405.030 through 19.405.050, at the lowest reasonable cost and risk to the utility and its customers, . . .” including an assessment of “Energy and nonenergy benefits and reductions of burdens to vulnerable populations and highly impacted communities; long-term and short-term public health and environmental benefits, costs, and risks; and energy security and risk;”

<sup>34</sup> WAC [480-100-620](#)(3).

<sup>35</sup> WAC [480-100-620](#)(13).

<sup>36</sup> WAC [480-100-610](#)(4)(c)(i)-(iii).

<sup>37</sup> WAC [480-100-620](#)(9).

time for the 2021 IRP, the requirement that the assessment be informed by the CIA does not waive the requirement for an assessment if the CIA is unavailable.<sup>38</sup> Each utility IRP must include an assessment of energy and nonenergy benefits and reductions of burdens to vulnerable populations and highly impacted communities; long-term and short-term public health and environmental benefits, costs, and risks; and energy security and risk using other sources of information relevant to the assessment. One use of this assessment is to inform the current distribution of benefits and burdens within a utility's service territory.

While it is hard to overstate the impact of CETA's clean energy mandates, the statute's customer benefit provisions are perhaps even more of a divergence from the utilities' (and the Commission's) traditional approaches to system planning and operations. For decades, utilities have been tasked with building a plan that can meet anticipated system needs at lowest reasonable cost, considering risk. CETA has added another priority that the utilities must achieve: ensuring all customers are benefiting from the transition to clean energy.

In future IRPs, this customer benefit mandate will largely focus on customer benefit indicators (CBIs). However, the utilities' inaugural CEIPs will emphasize CBI determination and details.<sup>39</sup> Instead, the CETA statutory and rule applicable to the 2021 planning cycle covers three topical areas: current-state assessment of economic, health, and environmental burdens and benefits;<sup>40</sup> maximum customer benefit modeling sensitivity discussed above;<sup>41</sup> and each utility's formation of an equity advisory group.<sup>42</sup>

The new economic, health, and environmental burdens and benefits assessment includes developing a current-state "snapshot" of the energy impacts and NEIs vulnerable populations and highly impacted communities experience within the electric IOUs' Washington service territories. Similarly, the IRP also needs to consider risks associated with long-term and short-term public health and environmental impacts as well as energy security.<sup>43</sup> These current conditions are the basis for determining whether the allocation of benefits and burdens from the utility's transition to clean energy results in equitable distribution.<sup>44</sup> This current-state assessment is critical for establishing baseline geographic and demographic datapoints, including identifying the vulnerable populations and highly impacted communities a given utility serves.<sup>45</sup> While the original intent was for electric IOUs to consider the Washington Department of Health's cumulative impact analysis (CIA) in developing their assessments,<sup>46</sup> the CIA's delay past December 31, 2020, does not waive the assessment requirement. Utilities should consider

---

<sup>38</sup> CETA Rulemaking Order at ¶ 54.

<sup>39</sup> WAC [480-100-640](#)(4).

<sup>40</sup> WAC [480-100-620](#)(9).

<sup>41</sup> WAC [480-100-620](#)(10)(c).

<sup>42</sup> WAC [480-100-625](#)(2)(b), WAC [480-100-655](#)(1)(b).

<sup>43</sup> WAC [480-100-620](#)(9).

<sup>44</sup> CETA Rulemaking Order at ¶ 53.

<sup>45</sup> See WAC [480-100-605](#) for definitions of "highly impacted community" and "vulnerable populations."

<sup>46</sup> RCW [19.280.030](#)(1)(k).



alternative references (e.g., U.S. Census data) relevant to the assessment.<sup>47</sup> Each electric utility must provide this assessment as part of its 2021 IRP to comply with CETA.<sup>48</sup>

Lastly, the equity advisory group required for utilities' forthcoming CEIPs should also inform IRP planning.<sup>49</sup> In this fashion, an IOU's comprehensive attention to vulnerable populations and highly impacted communities serve as a common thread linking successive CETA deliverables (i.e., IRPs, CEAPs, CEIPs).<sup>50</sup> Hence, each company should create an equity advisory group by May 1, 2021, to provide useful and timely input for the planning cycle. Further, this advisory group must be Washington-focused, comprised of Washington stakeholders, and include representatives from highly impacted communities and vulnerable populations. A multi-state utility cannot simply apply a systemwide advisory group to also serve as the company's equity advisory group to comply with CETA.

### *Conservation and CPA*

The Energy Independence Act (EIA) (RCW 19.285) was not replaced or modified by the passage of CETA. When the activities undertaken to comply with the EIA meet the requirements of CETA, they qualify for compliance with both statutes. Staff expects that the customer benefit mandate, with its provisions to account for additional nonenergy impacts such as public health benefits, and requirement to reduce of burdens to vulnerable populations and highly impacted communities, will make additional energy efficiency a cost-effective resource choice.

The new IRP rule requires an energy efficiency and conservation potential assessment of current and potential policies and programs needed to obtain all cost-effective conservation, efficiency, and load management improvements; including the ten-year conservation potential used in calculating a biennial conservation target under WAC 480-109.<sup>51</sup> This requirement should not change utility standard practice to any real degree. Staff expects that incremental improvements to the potential assessment are ongoing.

Each IRP should, at minimum, provide sufficient data points to calculate the ten-year, four-year, and two-year cost-effective conservation potential under both CETA and the EIA.

### *Demand Response*

The IRP must contain a demand response potential assessment of current and potential policies and programs needed to obtain all cost-effective demand response.<sup>52</sup> The statutory definition of demand response is broad and includes pricing structures (such as time of use or critical peak pricing), measure-based programs controlled by the utility, and behavioral programs that include

---

<sup>47</sup> CETA Rulemaking Order at ¶ 54.

<sup>48</sup> Conservation Energy Planning and Energy Policy staff customer benefit discussion, January 20, 2021.

<sup>49</sup> WAC [480-100-625](#)(2)(b), WAC [480-100-655](#)(1)(b).

<sup>50</sup> CETA Rulemaking Order at ¶ 162.

<sup>51</sup> WAC [480-100-620](#)(3)(b)(i).

<sup>52</sup> WAC [480-100-620](#)(3)(b)(ii).

an incentive payment.<sup>53</sup> In order to determine all cost-effective demand response as required by CETA, a potential assessment must include a broad range of options that include each of these types of demand response.<sup>54</sup>

### *Energy Storage*

Energy storage is identified in CETA and in the recently adopted WAC rules implementing CETA as a key component of the transition to clean energy.<sup>55</sup> Energy storage can address many types of system needs: energy, capacity, ancillary services, integration of renewable resources, balancing, spinning and non-spinning reserves, and emergency power. Energy storage can also play a role in deferring or preventing some transmission and distribution projects. The newly adopted WAC includes the following requirements related to energy storage:

- WAC 480-100-605 – energy storage included in definition of a DER.
- WAC 480-100-620(3)(a) – DER assessments in a utility’s IRP “must incorporate nonenergy costs and benefits not fully valued elsewhere within any integrated resource plan model.”
- WAC 480-100-620(3)(b)(iv) – storage identified as a DER “that may be installed by the utility or the utility’s customers,” and which the “IRP must assess[.]”
- WAC 480-100-620(5) – battery and pump storage identified as potential way to integrate renewable resources and address overgeneration events.
- WAC 480-100-620(11)(e) – acquisitions made after CETA’s passage must “rely on renewable resources and energy storage, insofar as doing so is at the lowest reasonable cost.”

While CETA has changed the regulatory landscape in Washington, energy storage is not new to the Commission.<sup>56</sup> Accurate modeling and optimal use of energy storage within a utility’s system planning tools was identified as the main limitation to full consideration of energy storage as a resource in the Commission’s policy statement. The value of energy storage is more apparent when a system planning model uses a granular timescale – the more granular the modeling timescale, such as an hourly or sub-hourly dispatch simulation, the more value of energy storage can be identified. Many IRP modeling tools’ optimizations are not typically performed on an hourly or sub-hourly basis.

In the policy statement, the Commission also discussed policy principles related to energy

---

<sup>53</sup> "Demand response" means changes in electric usage by demand-side resources from their normal consumption patterns in response to changes in the price of electricity, or to incentive payments designed to induce lower electricity use, at times of high wholesale market prices or when system reliability is jeopardized. "Demand response" may include measures to increase or decrease electricity production on the customer's side of the meter in response to incentive payments.

<sup>54</sup> WAC [480-100-610](#)(4)(a).

<sup>55</sup> RCW [19.405.040](#)(6)(a)(iii); RCW [19.405.050](#)(3)(c); WAC [480-100-620](#)(11)(e).

<sup>56</sup> *Report and Policy Statement on Treatment of Energy Storage Technologies in Integrated Resource Planning and Resource Acquisition*, Dockets [UE-151069](#) and U-161024, ¶ 15 (Oct. 11, 2017) (Policy statement identified “barriers that prevent energy storage from being fairly considered in resource planning and develop[ed] policies to overcome them”).

storage, many of which are also reflected in the newly adopted Part VIII of Chapter 480-100 WAC. We briefly summarize some components of the policy statement that continue to be relevant in the context of CETA and the revised WAC:

- Utilities should move toward a “new planning framework that more cohesively considers the relationship between generation, transmission, and distribution, allowing for a fair evaluation of hybrid resources such as energy storage.”<sup>57</sup>
- Utilities should adopt modeling platforms capable of sub-hourly modeling, and in the interim should use an external model capable of modeling the sub-hourly benefits of storage over the resource’s useful life, including transmission and distribution benefits, then calculate the net present value of those benefits and deduct that value from the resource’s modeled capital cost in the IRP.”<sup>58</sup>
- Utilities should consider at least “a reasonable, representative range of storage technologies and chemistries,” working with their advisory groups to identify these resources,<sup>59</sup>
- Utilities should vet storage cost assumptions by reviewing third-party data and applying “a reasonable learning curve to storage costs to account for forecasted declines.”<sup>60</sup>
- Finally, utilities should ensure that storage is considered in evaluating distribution system projects, including all locational benefits.<sup>61</sup>

As utilities use resource modeling software that is more sophisticated as compared with previous IRP cycles, and as CETA’s equity components are better understood, Staff expects that the importance of energy storage as a resource that can address multiple system needs and inequities will only grow, as will Staff’s focus on its accurate modeling and full consideration in each utility’s IRP.

#### *Qualifying Facilities – Avoided Cost Methodology*

The Public Utilities Regulatory Policies Act, or PURPA, requires utilities to purchase energy and capacity made available to them by qualified facilities (QFs) at a price based on the utility’s avoided costs.<sup>62</sup> The IRP estimates what the utility’s system needs, and at what cost. The goals of making avoided costs understandable for all stakeholders and of strengthening the connection between the IRP analysis and PURPA rates were both key factors driving the adoption of the new WAC 480-100-620(13) and (15).

---

<sup>57</sup> *Id.* at ¶ 36.

<sup>58</sup> *Id.* at ¶ 43.

<sup>59</sup> *Id.* at ¶ 46.

<sup>60</sup> *Id.* at ¶ 47.

<sup>61</sup> *Id.* at ¶ 48.

<sup>62</sup> The Commission revised its implementation of PURPA recently through a rulemaking that culminated in Chapter 480-106 WAC, which prescribes a methodology for setting PURPA rates for QFs with a nameplate capacity of 5 MW or less, and which requires that utilities file for the Commission’s consideration and approval a methodology to calculate avoided cost rates QFs larger than 5 MW. These methodologies were submitted by all three utilities and approved by the Commission in the following dockets: UE-191062 for PSE, UE-200455 for Avista, and UE-200573 for PacifiCorp.

- WAC 480-100-620(13): “Avoided cost and nonenergy impacts. The IRP must include an analysis and summary of the avoided cost estimate for energy, capacity, transmission, distribution, and greenhouse gas emissions costs. The utility must list nonenergy costs and benefits addressed in the IRP and should specify if they accrue to the utility, customers, participants, vulnerable populations, highly impacted communities, or the general public. The utility may provide this content as an appendix.”
- WAC 480-100-620(15): “Information relating to purchases of electricity from qualifying facilities. Each utility must provide information and analysis that it will use to inform its annual filings required under chapter 480-106 WAC. The detailed analysis must include, but is not limited to, the following components:
  - (a) A description of the methodology used to calculate estimates of the avoided cost of energy, capacity, transmission, distribution and emissions averaged across the utility; and
  - (b) Resource assumptions and market forecasts used in the utility's schedule of estimated avoided cost required in WAC 480-106-040 including, but not limited to, cost assumptions, production estimates, peak capacity contribution estimates and annual capacity factor estimates.”

### *Resource Adequacy and Uncertainty Analysis*

Resource adequacy (RA) studies in the IRP, including RA metrics and methodologies, are extremely important to ensure the lights stay on. Specifically, CETA requires an electric utility’s IRP to determine “resource adequacy metrics for the resource plan” and to identify “an appropriate resource adequacy requirement and measurement metric consistent with prudent utility practice.”<sup>63</sup> Staff’s review of resource adequacy in the IRP is broad in scope and involves all aspects of load service and modeling, including: energy, capacity, flexibility, availability, and performance characteristics of specific resources, such as demand-side, storage, wind resources, and batteries.<sup>64</sup> The analysis of the contribution to RA by storage and variable energy resources is of particular interest to Staff in the first post-CETA IRP review. Staff comments also address the incorporation of uncertainty into the RA assessment, often in the form of sensitivity analysis.

### *Distribution Planning Process*

The IRP rules require that the utility must include assessments of a variety of distributed energy resources and the effect of distributed energy resources on the utility's load and operations.<sup>65</sup> Further, the commission strongly encourages utilities to engage in a distributed energy resource planning process as described in RCW 19.280.100. If the utility elects to use a distributed energy resource planning process, the IRP should include a summary of these results.

<sup>63</sup> See RCW [19.280.030](#)(1)(g) and (i).

<sup>64</sup> WAC [480-100-620](#)(8).

<sup>65</sup> WAC [480-100-620](#)(3).

## Overview of Clean Energy Action Plan (CEAP) Requirements

To comply with statute and rules, each utility must develop a ten-year clean energy action plan that works toward implementing the IRP's lowest reasonable cost solution, including incorporation of the social cost of greenhouse gas emissions as a cost adder in its analysis.<sup>66</sup> As the intermediary plan between the IRP and the CEIP, the CEAP should identify the utility's ten-year resource "ramp" needed to meet energy, capacity, and associated flexibility in order to maintain and protect safe, reliable operation and balancing of the electric system, while achieving other clean energy transformation objectives.<sup>67</sup> Specifically, each CEAP should:

- meet clean energy transformation standards, including customer benefit provisions<sup>68</sup>;
- be informed by the utility's ten-year cost-effective conservation potential assessment;
- identify the potential cost-effective demand response and load management programs that may be acquired;
- establish a resource adequacy requirement and demonstrate how each resource, including renewable, nonemitting, and DERs, may reasonably be expected to contribute to meeting the utility's resource adequacy requirement;
- identify any need to develop new, or to expand or upgrade existing, bulk transmission and distribution facilities; and
- identify the nature and extent to which the utility intends to rely on an alternative compliance option identified under RCW 19.405.040(1)(b), if appropriate.

## Overview of Natural Gas IRP Statute and Rule Requirements by Topic

*Design Day (Planning Standard), particularly in the context of climate change data or future studies*

"Design day" refers to the peak temperature assumption that natural gas local distribution companies (LDCs) use to develop the plan for their natural gas supply and distribution pipeline systems. Neither statute nor rule impose any specific requirements for design day in the natural gas IRPs. Each LDC has the flexibility to identify its design day as appropriate. The utility must include the design day in its natural gas IRP, and provide a discussion justifying its selection, particularly addressing climate change risk of gradually increasing temperatures over time.

### *Upstream Emissions & SCGHG*

For the first time, statute requires LDCs to model a price on greenhouse gas emissions in the IRP. The statute specifies the price assigned to these emissions, but only for the purposes of

---

<sup>66</sup> WAC [480-100-620](#)(12).

<sup>67</sup> WAC [480-100-610](#)(4)(b).

<sup>68</sup> WAC [480-100-610](#).

setting conservation targets.<sup>69</sup> That price is set at the social cost of greenhouse gases (SCGHG), using a 2.5 percent discount rate, where the utility must also model and account for upstream emissions or “emissions occurring in the gathering, transmission, and distribution of natural gas to the end user.”

### *CPA and Conservation Targets*

RCW 80.28.380 requires gas companies to identify and acquire all conservation measures that are available and cost-effective, with an acquisition target approved by the commission every two years beginning in 2022. The target will be reviewed with the next conservation plan, but the IRP will be a main source of the data. A determination of cost-effective conservation in the IRP will be the start of the target calculation and must be clearly included in the IRP.

The cost-effectiveness analysis required by this section must include the costs of greenhouse gas emissions established in RCW 80.28.395. This could be included in the CPA or in a different IRP model. The IRP must include a clear description of how and where the SCGHG is included.

The targets must be based on a conservation potential assessment (CPA) prepared by an independent third party and approved by the commission. In order for Staff to recommend the commission approve a CPA there must be:

1. Transparent review of model.
2. Vetting through advisory groups.
3. Consistency with the Council’s method.
4. Internal consistency with load forecast.

While it has been the practice of the utilities to exclude gas transportation customers from participating in their conservation programs, Staff struggles to find an exclusion for gas transportation customers in the statutory language of RCW 80.28.380. Thus, in order to identify all cost-effective conservation, it will be necessary for the utility to separately consider and evaluate the energy efficiency potential of any customers too large to include in the CPA.<sup>70</sup> All available and cost-effective conservation potential must be included. The method chosen should be discussed with the advisory groups. Staff expects that if this conservation from large industrial customers is included in the IRP analysis, it is likely to reduce the utility’s need for distribution system improvements.

### *Renewable Natural Gas (RNG)*

Natural gas LDCs “must” offer their customers a voluntary RNG service by tariff.<sup>71</sup> Such service

<sup>69</sup> RCW [80.28.395](#). The conservation targets for LDCs are also a new requirement: HB 1257 for the first time requires LDCs to identify and acquire all cost-effective conservation and requires them to set two-year acquisition targets that will accomplish this goal. RCW [80.28.380](#).

<sup>70</sup> Potential assessments assume average market penetration and savings over sizeable populations. Conservation potential from large industrial customers, including transportation customers, are more appropriately treated individually than on an average basis.

<sup>71</sup> RCW [80.28.390](#).

would “replace any portion of the natural gas that would otherwise be provided by the gas company.” Second, LDCs “may” propose an RNG program that “would supply renewable natural gas for a portion of the natural gas sold or delivered to its retail customers.”<sup>72</sup> These two provisions contain an important distinction: The first *requires* LDCs to offer RNG to those customers that want it, while the second *allows* them to offer an RNG program that would serve all customers. The latter is subject to cost and environmental limitations. Analysis in the IRP will support the utility’s proposals in this area. Further, the utility’s IRP must discuss its plans concerning RNG.

### *Storage*

WAC 480-90-238(3) requires LDCs to “assess” opportunities to use company-owned or contracted storage in their IRPs, and also includes storage options as one of many resource options to be evaluated using a “consistent method to calculate cost-effectiveness.”

### *Distribution Planning*

Each LDC must provide a short-term plan outlining the specific actions to be taken to implement the long-range integrated resource plan during the two years following submission.<sup>73</sup> Each LDC also typically outlines a multi-year budget for engineering projects through a distribution scenario decision-making process. LDCs identify areas with growth forecasted to create capacity issues, focusing on areas for future improved distribution capacity needs, and highlight these projects in the IRP.

---

<sup>72</sup> RCW [80.28.385](#).

<sup>73</sup> WAC [480-90-238](#)(3)(h).

**Gall, James**

---

**From:** Andrew Argetsinger <aargetsinger@tyrenergy.com>  
**Sent:** Tuesday, February 16, 2021 4:31 PM  
**To:** Lyons, John; Gall, James  
**Cc:** Kevin Calhoon; Stuart McCausland  
**Subject:** [External] RE: Avista's Draft 2021 Electric IRP

John / James – Hope all is well. We are reviewing the current draft of the 2021 IRP and had a few questions:

- (1) We noticed that there was not a Lancaster PPA extension scenario included in the 2021 draft IRP. Why the change from last year?
- (2) Would you consider revising this draft to include a 10 year Lancaster PPA extension scenario? It seems unlikely to us that choosing not to extend the Lancaster PPA and turning around to immediately add 210+ MW of new peaking capacity in 2027 would be economically advantageous enough (compared to a Lancaster PPA extension scenario) to exclude the extension scenario from the IRP.
- (3) Will you share with us the unit parameters for Lancaster that would be used for a Lancaster PPA extension scenario? We'd like to understand what level of operational flexibility would be assumed in a Lancaster PPA extension scenario.

Please let me know if you have any questions or clarifications regarding these requests.

Best,

**Andrew Argetsinger**  
 Senior Director, Corporate Strategy  
**Tyr Energy, Inc.**  
 7500 College Blvd., Ste. 400  
 Overland Park, KS 66210  
 913.626.0772 (mobile)  
[aargetsinger@tyrenergy.com](mailto:aargetsinger@tyrenergy.com)

---

**From:** Lyons, John <John.Lyons@avistacorp.com>  
**Sent:** Monday, January 4, 2021 5:20 PM  
**To:**  
**Subject:** Avista's Draft 2021 Electric IRP

CAUTION: This email originated from outside your organization. Exercise caution when opening attachments or clicking links, especially from unknown senders.

Hello TAC Members,

Attached is a copy of the draft 2021 Electric IRP for your review. Please provide any comments or edits back to us by Monday, March 1, 2021 to me at [john.lyons@avistacorp.com](mailto:john.lyons@avistacorp.com). The final IRP and completed appendices will be filed on April 1, 2021 with the Idaho and Washington Commissions.

Our fifth and final TAC meeting will be held on Thursday, January 21, 2021. The meeting invitation and agenda will be available by the end of this week. There will also be an opportunity to provide written comments about the draft IRP to the Washington Commission and a public meeting on February 23, 2020. We will provide more details at the fifth TAC meeting.



Thank you for all of your participation in the 2021 IRP,

John Lyons  
Avista Corp.  
509-495-8515

CONFIDENTIALITY NOTICE: The contents of this email message and any attachments are intended solely for the addressee(s) and may contain confidential and/or privileged information and may be legally protected from disclosure. If you are not the intended recipient of this message or an agent of the intended recipient, or if this message has been addressed to you in error, please immediately alert the sender by reply email and then delete this message and any attachments.

---

**USE CAUTION - EXTERNAL SENDER**

**Do not click on links or open attachments that are not familiar.**

**For questions or concerns, please e-mail [phishing@avistacorp.com](mailto:phishing@avistacorp.com)**

November 14, 2020

To: John Lyons, John Barber, Dennis Vermillion, IPUC, WPUC & TAC committee members

From: Dave Van Hersett, TAC Member Emeritus

Subject: Biomass Generation omitted from considered IRP Options

Just read the draft IRP and found that Biomass Generation has been omitted from considered options for analysis. We have a substantial renewable biomass fuel supply in our Inland Empire. We should utilize it for the good of man rather than fuel for forest fires. So here is the case for Biomass Generation to provide new generation that meets CETA and brings back the forest products industry to the Inland Empire.

1. CETA approved three options for new power generation, Wind, Solar and Biomass.
2. Kettle Falls 50 MW Biomass generation plant has been operating since the early 80's utilizing sawmill biomass fuels generated during the processing of round logs to make rectangular lumber and other products.
3. The logging process does not utilize the tops and branches of the tree. The tops and branches equal the weight of the saw logs delivered to the sawmill.
4. Sawmill biomass fuel is ten percent of the weight of the saw logs brought into the sawmill.
5. The tops and branches weigh ten times the weight of the sawmill biomass fuel. This ratio is dependent on type and specie of forest growth.
6. Since the 50 MW Kettle falls Biomass power plant utilizes sawmill biomass fuels, the tops and branches logging biomass would have enough fuel for 500 MW of biomass generation.
7. Biomass fueled generation works when the sun does not shine and works when the wind is not blowing and can be scheduled to meet the load profile of the customers. Thus, less generation capacity is needed due to load factors of Wind and Solar to meet given customer loads.
8. Avista has the experience and trained staff to operate thermal biomass power generation plants.
9. Note that every year Logging fuels are left in the forest to rot and/or be fuels for forest fires. This is because the trees grow every year independent of politics. Forest fuels are a renewable bioenergy resource. We have been wasting this energy source for years.

Utilizing Logging Biofuels would reduce the fuel available for forest fires. Utilizing Logging biofuels would provide excellent forest management practices to optimize the production of timber products for the good of mankind. Eliminating forest fire fuels would bring back timber supplies to the 11 former sawmill towns in the Inland Empire. Bringing back the forest products industry would bring back jobs needed for the ever-increasing population (2% per year).

Both Wind and Solar receive financial incentives to make them competitive with existing generation resources. Biomass fuels should qualify for the same incentives. These incentives would then improve the cost of recovering the logging biofuels and delivering them to one or more power plant locations. The assumption here is that the wind and solar resource utilized in the draft IRP will continue to receive incentives.

A typical sawmill supports a 5 MW biomass power plant utilizing sawmill biomass fuel. Thus, each sawmill's logging biofuels would support a 50 MW biomass power plant utilizing logging biofuels. This would minimize fuel transportation expense. Integrating 55 MW into the local electrical distribution system would be easier than one 500 MW power plant.

As the demand for wind and solar increases, the supply of these resources will be subject to the market demand. The price of wind and solar will likely increase as demand increases and delivery extended. Biomass fueled power plants are readily available today from several experienced builders and contractors.

From an operating perspective, Avista could go into partnerships with the sawmills, building and operating the biomass power plants. The sawmills would provide fuel and utilize steam for their dry kiln operations. Timber from area forests has been for hundreds of years assuring a firm fuel supply. Sawmills have been operating in this area since the 1800's and will continue to operate as long as the ever-growing population requires timber products for their use. In the recent 40 years the supply of timber has been subject to politics and the degrading of forest management practices.

The above concept would be like the former TWWPCO management committing to the development and investing in hydro and fossil fuel power plants to insure a reliable and low-cost power cost for its customers. TWWPCO sold excess capacity until it was needed for its own customers loads.

**Biomass generation option should be included as one of the alternatives evaluated to determine relative economics of the three approved new generation types, wind, solar and biomass here in the Inland Empire. We have the moral obligation to utilize the forests for the benefit of mankind not to fuel forest fires to destroy property and kill our neighbors.**

## Guest Commentary

### **THE GREEN OPPORTUNITY: Executive Summary**

The 40-year Green movement has brought devastation to the forests, destruction to property and death to inhabitants and created 11 sawmill ghost towns in the Inland Empire. In 2020 the Conservation Energy Transformation Act (CETA) was enacted into law providing the key ingredient enabling complete recovery from 40 years of devastation. This act requires that any new electric generation be from Wind, Solar and *BIOMASS*. *Biomass* is wood fuel remaining from harvesting forests to make products for mankind. We now can bring back the vibrant forest, clean air, and return the forest products industry and jobs for the inhabitants of the Inland Empire.

**A little history:** When I grew up in Spokane in the 50's I do not remember smoke filled skies at the lake in the summer. We had lots of towns participating in the Lilac Parade, logging contests, and fun high school games all around the area.

I remember EXPO 74. All the rides and summer entertainment it brought. EXPO 74 brought the River Front Park that cleaned up the town and provide a major improvement to the Spokane downtown. This came about from the foresight and leadership of local businesses and government at the time. No smoke-filled skies during the EXPO.

Now it is time for our current leadership to take advantage of the enabling CETA law to bring back our forest products industry and the 30,000 or so jobs with it. We need this to provide employment for our children and our ever-growing population. We need to utilize our forests for the benefit of mankind rather than fuel for forest fires and to clean up the air.

### **BIOMASS FOREST RESOURCES is our solution!**

A BIOMASS project is an electric generating plant that uses wood waste for fuel instead of fossil fuels. The Kettle Falls 50 Megawatt Biomass fueled power plant has been operating since the 1980's. What do we have to do to make this happen?

First, we have to educate our local governments, our captains of industry, our utility leadership, and our congressional representatives on the biomass recovery opportunity that is here today. Then they must put their heads and resources together for the betterment of its citizens and the husbanding of our local forest resources.

Second, we have to pre-license Biomass Project sites at the former sawmill towns. These sites are in the logical locations to minimize the cost of the transportation of the forest harvested products. These sites will receive a very enthusiastic approval from the occupants of the former mill towns. Pre-licensing sites will prove that the public has an extremely high approval of biomass electric generation. Pre-licensing sites will verify the acceptance of utilization of the local forests for the benefit of mankind rather than fuel for forest fires. The local utilities have the skills and resources to accomplish this.

Third, the forest management practices must be changed to allow the use of timber for products for mankind instead of growing fuel for forest fires. This will require the assistance of our congressional representatives to make changes to US Forest Service and State forest management practices.

Fourth, the utilities in this area must require that Biomass be their preferred new generation resource instead of Wind and Solar. They must incorporate the benefits of the renewed 10,000 mill jobs and supporting 30,000 jobs in our area into their financial evaluations when comparing to the Wind and Solar options. The infrastructure for the utility distribution systems remains in place from the days of the operating sawmills. No major transmission systems are needed as compared to Wind and Solar. Benefits from the Biomass investment to the local area would include more jobs, more tax basis to support local government and schools, reduction in forest fire prevention and recovery costs, and cleaner air to name a few.

Finally, bringing back the forest products industry will create a major economic boon to the Inland Empire. As our population grows our children will not have to leave the area to find employment. Our region's natural resource will be returned to be used to benefit mankind. The forest and our population grow every year independent of politics.

***Bringing back the forest products industry will be our legacy!!***

Now for more detail:

### ***Consequences of Going Green***

The consequences of going green for the past 40 years are as follows:

1. More fuel for forest fires, property destruction and killing persons.
2. Loss of timber supplies for local sawmills.
3. Lost jobs for the inland empire population.
4. Loss of land for growing food.
5. Loss of scenery viewing from wind and solar.
6. Loss of investment in Inland Empire towns.
7. Loss of tax revenue to support local schools and government.
8. Double to triple electric rates.
9. Triple the generation capacity installed needed to meet customer loads.
10. Increased mining of resources over traditional generation to provide materials to manufacture and build wind and solar.
11. Loss of birds. Wind power plants kill 30% of the bird population from blade strikes.

### ***Reflections of a lifetime***

Author: A 5<sup>th</sup> generation of Spokaneite, 82-year-old, Veteran, Retired Professional Engineer, businessman, four great children, Jaycee, Rotarian, Eagle Scout, Scout Master, Soccer Coach, Spokane School District Citizens Advisory Committee, 50-year home owner in Spokane, NCHS graduate, WSU BSME & MBA. Career in coal, oil, natural gas and biomass fueled Power Plant Development and performance-based Energy Conservation in the commercial, industrial and institutional sectors. I am 82 now in my twilight and have limited time left to pass on my observations of a lifetime. My classmates are showing up in an ever-increasing number in the obituary notices daily. Time is getting short for me give something back. I am a product of the values of our area and the education system provided by our citizens. My name is Dave Van Hersett, SR., a proud Spokane citizen.

## INLAND EMPIRE NATURAL RESOURCES

We have been blessed with the following natural resources in our area to manage and harvest for the benefit of mankind. They are (1) Water, (2) Mineral resources underground, (3) farmlands to produce food, (4) forests to grow products for mankind and finally, our (5) population. We need to husband each of the resources to support our ever-growing population.

Our forefathers found minerals, gold, silver & lead in the Kellogg wilderness. Timber from the forests built the railroads to ship the minerals to markets. Timber provided housing and heat for the population. Water was used to make electric power to enable mining, industry and support the population. We enjoy the benefits of our predecessors efforts.

## AVISTA ABANDONED THE MAJORITY:

Since renaming The Washington Water Power Company to Avista we customers have increased the officers compensation from hundreds of thousands to millions. This makes their compensation ten times that of the President of the USA and the Gov of Washington State. The average income of Avista customers is \$40,000 per year, about 100 times less than the Avista management compensation. For what we customers pay Avista management, we expect that they can accomplish the impossible like Superman and make real improvements for their 300,000 customers. So, what has the Avista MGT done for its customers?

**(1) They have adopted a strategy to increase the customer monthly billing by up to three times.**

They took their knee to the Green movement indifferent to the will of majority of its customers. **99% of the customers chose not to participate in Avista's option's to purchase higher cost wind and solar power.** The customers gave an extraordinarily strong signal that they want reliable and low-cost electrical power. The Avista Utility 20 year plan for generation removes fossil fuel generation and adds wind and solar. The utility has not come up with any plans to develop additional revenue to offset the huge increase coming to our energy costs and bills.

## **(2) They abandoned their Forest Products industry**

The result is the creation of 11 ghost towns from the loss of the sawmills in these towns. These natural forest industries were one of the reasons that founded the WWP over 100 years ago in 1889. The forest products industry has been abandoned to grow fuel for forest fires instead of products for mankind. This accounts for a loss of over 10,000 forest industry jobs and the 30,000 people supporting the forest products industry in Avista's service area. Where do these people go now? Our children leave the area to find employment. To get an idea of the impact on our forest products towns compare the vibrant town of Colville with former sawmill towns like Usk, Cusick, Republic, Kellogg, Athol to name a few.

## **(3) Tried to sell the utility two times.**

Washington and Idaho Utility Commissions did not approve these sales. In both cases the management would have received a substantial sale commission. I was never in favor of selling our utility.

## **Historical Innovation and Leadership in Inland Empire**

We enjoy the benefits of our forefathers innovation and leadership to bring benefits to the local economy and provide employment of our population. In the 1889 The Washington Water Power Company was formed to provide power and energy to the industries of the time, timber, mining and agriculture. Hydro power was developed to provide low cost and reliable energy for the ever-growing industry and populations of this region. Noxon and Cabinet Hydro power projects were developed to serve the ever-increasing population and industrial customers. The 1400 MW Centralia Coal Plant and Coal Strip projects were partnered in to provide reliable and low-cost power for the ever-growing customer loads. Excess power was sold to other utilities here in the PNW to keep our energy costs low.

In the 70's TWWPCO developed the Kettle Falls 50 megawatt Biomass Power Plant utilizing sawmill wood waste that was disposed of in sawmill teepee burners smoking up the air. This biomass project provided a waste disposal solution for the forest products industry in the Inland Empire. This plant is operating today.



### **Proposed Action Plan to offset higher energy costs:**

In 2020 WA legislature passed a law that requires the utilities to eliminate the use of plentiful fossil fuels to provide electric power to its customers. It is called the Clean Energy Transformation Act (CETA). Eliminating fossil fuel generation will triple our electric rates. The approved new electric generation resources are Wind, Solar and Biomass.

**CETA creates the opportunity to develop up to 750 MW of renewable biomass** generation utilizing our regions biofuels from the improved management of our region's forests. Excess generation would be sold to offset the increase in power costs from the adoption of wind and solar generation in place of low cost and reliable fossil fueled power generation. This similar to selling our excess hydro generation until needed for our customers. These biomass projects would also bring back thousands of jobs to the abandoned forest products industry and revive the ghost towns in our area. The infrastructure for these ghost towns is still in place so the incremental revenue benefits would again benefit the customers.

**Develop Renewable Bioenergy Power Plants** like Kettle Falls. Install 5 to 10 MW wood fueled power plants at each of the 11 ghost towns former sawmills and 50 MW like Kettle Falls Power Plant at each of these ghost towns to bring back the forest products industry. Initiate an aggressive program to clean up the forests in our area due to the lack of management for the past 40 years. Refer to the Vaagen Brothers web site to see what a managed forest looks like. Cleaning up the forest floor will bring biomass fuels along with the residue from logging operations. There is some 750 MW of biofuels for renewable electric generation available from the forests in the Inland Empire.

Solicit the help from our congresswoman, Kathy McMorris Rodgers to change federal laws to enable the forest management practices to support utilizing biomass for benefit of mankind instead for fuel for forest fires. We need jobs for our population, we do not want to destroy forests, property or kill persons.

Developing these generation resources will give us the ability to sell excess energy to the other areas in WA state that will have to meet the 2005 date required by CETA regulation passed by our Legislature. The sale of this renewable energy will offset the higher cost of wind and solar such that our electric rates will

not increase three times. This development effort will also bring 10,000 forest products jobs and their supporting 30,000 population back to our area and reduce the fuel available for forest fires. We will go back to the notion of raising trees to produce products for the ever-increasing population and not for fuel for forest fires. Let's provide jobs for our children instead of forcing them to leave our area for employment.

### **Pre-license Biomass Project sites**

Development of Biomass generation requires more effort than wind and solar. Biomass plants utilizing forest residues will require changes to forest management practices, changes to new generation priorities, enacting legislative changes and changes to forest industry logging practices. This is in addition to the more complicated Environmental Impact Statements and a myriad of permits from multiple agencies. Our utility management can make these changes happen for the benefit of their customers. It is easier to develop wind and solar as you only need vacant land.

Wind and solar benefit from the government incentives to reduce their net generation costs to compete with fossil fuel generation. These same financial incentives should be made available to Biomass Generation. The utility should be working to make this happen.

To make Biomass electric generation possible, the utilities pre-license plants sites would enable biomass project contractors to be competitive with wind and solar proposals. Pre-licensing will eliminate the unknown from their proposals and allow them to focus on what they do best, build power plants. Thus, we would get competitive prices and that is good for the customers and the region forests.

### **Renewable generation from Garbage.**

Populations generate garbage, a fuel. The fuel heating value of garbage is the same as forest fuels. Each person generates about 1 ton of garbage per year. Thus the 500,000 persons in our area generate about 500,000 tons of fuel per year, enough for 50 MW of power. The city of Spokane uses about 300 MW of electric power. We have an existing 25 MW at the waste-to-energy plant at the Spokane Airport. There is enough unused fuel in our area for an additional 25 MW from Spokane County and Coeur' d Alene's garbage.

Right now, the extra non burned garbage is hauled 210 miles by truck to Roosevelt, Washington landfill. This creates land that is unusable for decades. A local example of this is the former land fill you can see south of the I-90 at Liberty Lake. The vacant land between the apartment units on the hill is a former land fill site.

### **TIME FOR OUR LEADERSHIP TO STEP UP AND CREATE A LEGACY**

**Only once in your lifetime do you get the opportunity to really create a legacy that will stand the test of time. Bringing back the forest products industry to the Inland Empire is one of those unique opportunities. Our home grown talent can make this happen just like our predecessors. We ,the customers, will all benefit from this effort and like our predecessors you will have the gratitude of your fellow men and women forever. This task will not be easy. It will take the cooperative efforts of all of us to make it happen. So let us be like our predecessors who against all odds, made legacies like mining, hydro power, forest products industry, EXPO 74 to name a few.**

# 2021 Electric Integrated Resource Plan

## Appendix D – Confidential Historical Generation Operation Data

Idaho – Confidential pursuant to Sections 74-109, Idaho Code

Washington – Confidential per WAC 480-07-160





# 2021 Electric Integrated Resource Plan

## Appendix E – AEG Conservation Potential & Demand Response Potential Assessments





# AVISTA CONSERVATION POTENTIAL ASSESSMENT FOR 2022-2045

December 1, 2020

Report prepared for:  
AVISTA CORPORATION

Energy Solutions. Delivered.

This work was performed by

Applied Energy Group, Inc. (AEG)  
500 Ygnacio Valley Rd, Suite 250  
Walnut Creek, CA 94596

Project Director: E. Morris

Project Manager: K. Walter

Project Team: G. Wroblewski

M. McBride

K. Marrin

T. Williams

AEG would also like to acknowledge the contributions of

R. Finesilver

L. Haley

J. Gall





# CONTENTS

<b>1</b>	<b>INTRODUCTION</b> .....	<b>9</b>
	Abbreviations and Acronyms .....	10
<b>2</b>	<b>ANALYSIS APPROACH AND DATA DEVELOPMENT</b> .....	<b>13</b>
	Overview of Analysis Approach .....	13
	LoadMAP Model .....	13
	Definitions of Potential .....	15
	Market Characterization .....	15
	Baseline Projection .....	17
	Conservation Measure Analysis .....	17
	Representative Conservation Measure Data Inputs .....	19
	Conservation Potential .....	21
	Data Development .....	21
	Data Sources .....	21
	AEG Data .....	23
	Other Secondary Data and Reports .....	24
	Data Application .....	24
	Data Application for Market Characterization .....	24
	Data Application for Market Profiles .....	25
	Data Application for Baseline Projection .....	25
	Conservation Measure Data Application .....	31
	Data Application for Technical Achievable Potential .....	32
<b>3</b>	<b>MARKET CHARACTERIZATION AND MARKET PROFILES</b> .....	<b>33</b>
	Energy Use Summary .....	33
	Residential Sector .....	34
	Commercial Sector .....	41
	Industrial Sector .....	48
<b>4</b>	<b>BASELINE PROJECTION</b> .....	<b>53</b>
	Residential Sector .....	53
	Annual Use .....	53
	Commercial Sector Baseline Projections .....	56
	Annual Use .....	56
	Industrial Sector Baseline Projections .....	59
	Annual Use .....	59
	Summary of Baseline Projections across Sectors and States .....	61
	Annual Use .....	61
<b>5</b>	<b>CONSERVATION POTENTIAL</b> .....	<b>62</b>
	Overall Summary of Energy Efficiency Potential .....	62
	Summary of Annual Energy Savings .....	62
	Summary of Conservation Potential by Sector .....	66
	Residential Conservation Potential .....	67
	Commercial Conservation Potential .....	73

	Industrial Conservation Potential.....	78
<b>6</b>	<b>DEMAND RESPONSE POTENTIAL.....</b>	<b>A-1</b>
	Market Characterization.....	A-1
	Market segmentation.....	A-1
	Customer Counts by Segment.....	A-2
	Forecasts of Winter and Summer Peak Demand.....	A-3
	System and Coincident Peak Forecasts by State.....	A-4
	Equipment End Use Saturation.....	A-6
	DSM Program Options.....	A-8
	Program Descriptions.....	A-8
	Program Assumptions and Characteristics.....	A-11
	Other Cross-cutting Assumptions.....	A-18
	DR Potential and Cost Estimates.....	A-19
	Integrated Potential Results.....	A-19
	Winter TOU Opt-in Scenario.....	A-19
	Cost Results.....	A-22
	Winter TOU Opt-out Scenario.....	A-23
	Cost Results.....	A-26
	Summer TOU Opt-in Scenario.....	A-27
	Cost Results.....	A-31
	Summer TOU Opt-out Scenario.....	A-32
	Cost Results.....	A-36
	Stand-alone Potential Results.....	A-37
	Winter Results.....	A-37
	Summer Results.....	A-40
	Ancillary Services.....	A-44
	Winter Results.....	A-44
<b>A</b>	<b>MARKET PROFILES.....</b>	<b>A-1</b>
<b>B</b>	<b>MARKET ADOPTION (RAMP) RATES.....</b>	<b>B-1</b>
<b>C</b>	<b>MEASURE DATA.....</b>	<b>C-1</b>

## LIST OF FIGURES

Figure 2-1	LoadMAP Analysis Framework.....	14
Figure 2-2	Approach for Conservation Measure Assessment.....	18
Figure 3-1	Sector-Level Electricity Use in Base Year 2017, Washington.....	33
Figure 3-2	Sector-Level Electricity Use in Base Year 2017, Idaho.....	34
Figure 3-3	Residential Electricity Use and Winter Peak Demand by End Use (2017), Washington.....	35
Figure 3-4	Residential Electricity Use and Winter Peak Demand by End Use (2017), Idaho...	36
Figure 3-5	Residential Intensity by End Use and Segment (Annual kWh/HH, 2017), Washington.....	37
Figure 3-6	Residential Intensity by End Use and Segment (Annual kWh/HH, 2017), Idaho....	38
Figure 3-7	Commercial Electricity Use and Winter Peak Demand by End Use (2017), Washington.....	43
Figure 3-8	Commercial Electricity Use and Winter Peak Demand by End Use (2017), Idaho.....	44
Figure 3-9	Commercial Electricity Usage by End Use Segment (GWh, 2017), Washington....	45
Figure 3-10	Commercial Electricity Usage by End Use Segment (GWh, 2017), Idaho.....	45
Figure 3-11	Industrial Electricity Use and Winter Peak Demand by End Use (2017), All Industries, WA.....	48
Figure 3-12	Industrial Electricity Use and Winter Peak Demand by End Use (2017), All Industries, ID.....	49
Figure 4-1	Residential Baseline Projection by End Use (GWh), Washington.....	54
Figure 4-2	Residential Baseline Projection by End Use – Annual Use per Household, Washington.....	55
Figure 4-3	Residential Baseline Projection by End Use (GWh), Idaho.....	56
Figure 4-4	Residential Baseline Sales Projection by End Use – Annual Use per Household, Idaho.....	56
Figure 4-5	Commercial Baseline Projection by End Use, Washington.....	58
Figure 4-6	Commercial Baseline Projection by End Use, Idaho.....	58
Figure 4-7	Industrial Baseline Projection by End Use (GWh), Washington.....	60
Figure 4-8	Industrial Baseline Projection by End Use (GWh), Idaho.....	60
Figure 4-9	Baseline Projection Summary (GWh), WA and ID Combined.....	61
Figure 5-1	Summary of EE Potential as % of Baseline Projection (Annual Energy), Washington.....	64
Figure 5-2	Summary of EE Potential as % of Baseline Projection (Annual Energy), Idaho.....	64
Figure 5-3	Baseline Projection and EE Forecast Summary (Annual Energy, GWh), Washington.....	65
Figure 5-4	Baseline Projection and EE Forecast Summary (Annual Energy, GWh), Idaho.....	65
Figure 5-5	Technical Achievable Conservation Potential by Sector (Annual Energy, GWh).....	66
Figure 5-6	Residential Conservation Savings as a % of the Baseline Projection (Annual Energy), Washington.....	68

Figure 5-7	Residential Conservation Savings as a % of the Baseline Projection (Annual Energy), Idaho.....	68
Figure 5-8	Residential Technical Achievable Savings Forecast (Cumulative GWh), Washington.....	70
Figure 5-9	Residential Technical Achievable Savings Forecast (Cumulative GWh), Idaho...	72
Figure 5-10	Commercial Conservation Savings (Energy), Washington.....	74
Figure 5-11	Commercial Conservation Savings (Energy), Idaho.....	74
Figure 5-12	Commercial Technical Achievable Savings Forecast (Cumulative GWh), Washington.....	76
Figure 5-13	Commercial Technical Achievable Savings Forecast (Cumulative GWh), Idaho.....	78
Figure 5-14	Industrial Conservation Potential as a % of the Baseline Projection (Annual Energy), Washington.....	79
Figure 5-15	Industrial Conservation Potential as a % of the Baseline Projection (Annual Energy), Idaho.....	80
Figure 5-16	Industrial Technical Achievable Savings Forecast (Cumulative GWh), Washington.....	82
Figure 5-17	Industrial Technical Achievable Savings Forecast (Annual Energy, GWh), Idaho.....	83
Figure 6-1	Contribution to Estimated System Coincident Peak Forecast by State (Summer).....	A-5
Figure 6-2	Contribution to Estimated System Coincident Peak Forecast by State (Winter).....	A-6
Figure 6-3	Summary of Potential Analysis for Avista (TOU Opt-In Winter Peak MW @Generator).....	A-20
Figure 6-4	Summary of Winter Potential Analysis for Avista (TOU Opt-Out MW @Generator).....	A-24
Figure 6-5	Summary of Summer Potential by Option (TOU Opt-In MW @Generator).....	A-28
Figure 6-6	Summary of Summer Potential – TOU Opt-Out (MW @Generator).....	A-32
Figure 6-7 and Table A-1	show the winter demand savings from individual DR options for selected years of the analysis. These savings represent stand-alone savings from all available DR options in Avista’s Washington and Idaho service territories.....	A-37
Figure 6-8	Summary of Potential Analysis for Avista (Winter Peak MW @Generator).....	A-38
Figure 6-9	Summary of Summer Potential by Option (MW @Generator).....	A-41

## LIST OF TABLES

Table 1-1	Explanation of Abbreviations and Acronyms.....	10
Table 2-1	Overview of Avista Analysis Segmentation Scheme.....	16
Table 2-2	Example Equipment Measures for Central AC – Single-Family Home.....	20
Table 2-3	Example Non-Equipment Measures – Single Family Home, Existing.....	20
Table 2-4	Number of Measures Evaluated .....	20
Table 2-5	Data Applied for the Market Profiles .....	26
Table 2-6	Data Needs for the Baseline Projection and Potentials Estimation in LoadMAP...	27
Table 2-7	Residential Electric Equipment Standards.....	28
Table 2-8	Commercial Electric Equipment Standards.....	29
Table 2-9	Industrial Electric Equipment Standards.....	30
Table 2-10	Data Needs for the Measure Characteristics in LoadMAP.....	31
Table 3-1	Avista Sector Control Totals (2017), Washington.....	33
Table 3-2	Avista Sector Control Totals (2017), Idaho.....	34
Table 3-3	Residential Sector Control Totals (2017), Washington.....	34
Table 3-4	Residential Sector Control Totals (2017), Idaho.....	35
Table 3-5	Average Market Profile for the Residential Sector, 2017, Washington.....	39
Table 3-6	Average Market Profile for the Residential Sector, 2017, Idaho .....	40
Table 3-7	Commercial Sector Control Totals (2017), Washington.....	41
Table 3-8	Commercial Sector Control Totals (2017), Idaho .....	42
Table 3-9	Average Electric Market Profile for the Commercial Sector, 2017, Washington...	46
Table 3-10	Average Electric Market Profile for the Commercial Sector, 2017, Idaho .....	47
Table 3-11	Industrial Sector Control Totals (2017).....	48
Table 3-12	Average Electric Market Profile for the Industrial Sector, 2017, Washington.....	51
Table 3-13	Average Electric Market Profile for the Industrial Sector, 2017, Idaho.....	52
Table 4-1	Residential Baseline Sales Projection by End Use (GWh), Washington .....	54
Table 4-2	Residential Baseline Sales Projection by End Use (GWh), Idaho .....	55
Table 4-3	Commercial Baseline Sales Projection by End Use (GWh), Washington .....	57
Table 4-4	Commercial Baseline Sales Projection by End Use (GWh), Idaho.....	57
Table 4-5	Industrial Baseline Projection by End Use (GWh), Washington.....	59
Table 4-6	Industrial Baseline Projection by End Use (GWh), Idaho .....	59
Table 4-7	Baseline Projection Summary (GWh), WA and ID Combined .....	61
Table 5-1	Summary of EE Potential (Annual Energy, GWh), Washington.....	63
Table 5-2	Summary of EE Potential (Annual Energy, GWh), Idaho.....	63
Table 5-3	Technical Achievable Conservation Potential by Sector (Annual Use), WA and ID .....	66
Table 5-4	Residential Conservation Potential (Annual Energy), Washington.....	67
Table 5-5	Residential Conservation Potential (Annual Energy), Idaho.....	67
Table 5-6	Residential Top Measures in 2019 (Annual Energy, MWh), Washington .....	69
Table 5-7	Residential Top Measures in 2019 (Annual Energy, MWh), Idaho.....	71
Table 5-8	Commercial Conservation Potential (Annual Energy), WA .....	73

Table 5-9	Commercial Conservation Potential (Annual Energy), Idaho .....	73
Table 5-10	Commercial Top Measures in 2019 (Annual Energy, MWh), Washington .....	75
Table 5-11	Commercial Top Measures in 2019 (Annual Energy, MWh), Idaho.....	77
Table 5-12	Industrial Conservation Potential (Annual Energy), WA .....	78
Table 5-13	Industrial Conservation Potential (Annual Energy), Idaho .....	79
Table 5-14	Industrial Top Measures in 2019 (Annual Energy, GWh), Washington.....	81
Table 5-15	Industrial Top Measures in 2019 (Annual Energy, GWh), Idaho.....	82
Table 6-1	Market Segmentation .....	A-2
Table 6-2	Baseline C&I Customer Forecast by State and Customer Class.....	A-2
Table 6-3	Baseline System Winter Peak Forecast (MW @Meter) .....	A-3
Table 6-4	Winter Load Factors and Baseline Coincident Peak Forecast by Segment (MW @Meter).....	A-4
Table 6-5	Summer Load Factors and Baseline Coincident Peak Forecast by Segment (MW @Meter).....	A-4
Table 6-6	2017 End Use Saturations by Customer Class, Washington.....	A-7
Table 6-7	2017 End Use Saturation by Customer Class, Idaho.....	A-7
Table 6-8	Class 1 DSM Products Assessed in the Study.....	A-12
Table 6-9	DSM Steady-State Participation Rates (% of eligible customers) .....	A-13
Table 6-10	DSM Per Participant Impact Assumptions.....	A-15
Table 6-11	DSM Program Operations Maintenance, and Equipment Costs (Washington) .	A-16
Table 6-12	Marketing, Recruitment, Incentive, and Development Costs (Washington) ....	A-17
Table 6-13	DSM Program Operations Maintenance, and Equipment Costs (Idaho) .....	A-17
Table 6-14	Marketing, Recruitment, Incentive, and Development Costs (Idaho).....	A-18
Table 6-15	Achievable DR Potential by Option (TOU Opt-In Winter MW @Generator).....	A-20
Table 6-16	Achievable DR Potential by Option for Washington (TOU Opt-In Winter MW @Generator) .....	A-21
Table 6-17	Achievable DR Potential by Option for Idaho (TOU Opt-In Winter MW @Generator) .....	A-22
Table 6-18	DR Program Costs and Potential (TOU Opt-In Winter).....	A-23
Table 6-19	Achievable DR Potential by Option – TOU Opt-Out (Winter MW @Generator) .	A-24
Table 6-20	Achievable DR Potential by Option for Washington – TOU Opt-Out (MW @Generator) .....	A-25
Table 6-21	Achievable DR Potential by Option for Idaho – TOU Opt-Out (MW @Generator) .....	A-26
Table 6-22	DR Program Costs and Potential – TOU Opt Out Winter.....	A-27
Table 6-23	Achievable DR Potential by Option TOU Opt-In (Summer MW @Generator) ....	A-28
Table 6-24	Achievable DR Potential by Option for Washington TOU Opt-In (Summer MW @Generator) .....	A-29
Table 6-25	Achievable DR Potential by Option for Idaho TOU Opt-In (Summer MW @Generator) .....	A-30
Table 6-26	DR Program Costs and Potential – Summer TOU Opt-In .....	A-31
Table 6-27	Achievable DR Potential by Option – TOU Opt-Out (Summer MW @Generator)A-	34
Table 6-28	Achievable DR Potential by Option for Washington – TOU Opt-Out (Summer MW @Generator) .....	A-35

Table 6-29	Achievable DR Potential by Option for Idaho – TOU Opt-Out (Summer MW @Generator) .....	A-35
Table 6-30	DR Program Costs and Potential – Summer TOU Opt-Out .....	A-36
Figure 6-7 and Table 6-31 show the winter demand savings from individual DR options for selected years of the analysis. These savings represent stand-alone savings from all available DR options in Avista’s Washington and Idaho service territories.....		
		A-37
Table 6-32	Achievable DR Potential by Option (Winter MW @Generator).....	A-38
Table 6-33	Achievable DR Potential by Option for Washington (Winter MW @Generator).	A-39
Table 6-34	Achievable DR Potential by Option for Idaho (Winter MW @Generator) .....	A-40
Table 6-35	DR Program Costs and Potential (Winter).....	<b>Error! Bookmark not defined.</b>
Table 6-36	Achievable DR Potential by Option (Summer MW @Generator) .....	A-41
Table 6-37	Achievable DR Potential by Option for Washington (Summer MW @Generator)	A-42
Table 6-38	Achievable DR Potential by Option for Idaho (Summer MW @Generator).....	A-43
Table 6-39	DR Program Costs and Potential – Summer.....	<b>Error! Bookmark not defined.</b>
Table A-1	Washington Residential Single Family Market Profile.....	<b>Error! Bookmark not defined.</b>
Table A-2	Washington Residential Multi Family Market Profile.....	<b>Error! Bookmark not defined.</b>
Table A-3	Washington Residential Mobile Home Market Profile .....	<b>Error! Bookmark not defined.</b>
Table A-4	Washington Residential Low-Income Market Profile.....	<b>Error! Bookmark not defined.</b>
Table A-5	Washington Commercial Large Office Market Profile .....	<b>Error! Bookmark not defined.</b>
Table A-6	Washington Commercial Small Office Market Profile.....	<b>Error! Bookmark not defined.</b>
Table A-7	Washington Commercial Retail Market Profile.....	<b>Error! Bookmark not defined.</b>
Table A-8	Washington Commercial Restaurant Market Profile.....	<b>Error! Bookmark not defined.</b>
Table A-9	Washington Commercial Grocery Market Profile.....	<b>Error! Bookmark not defined.</b>
Table A-10	Washington Commercial Health Market Profile .....	<b>Error! Bookmark not defined.</b>
Table A-11	Washington Commercial College Market Profile .....	<b>Error! Bookmark not defined.</b>
Table A-12	Washington Commercial School Market Profile.....	<b>Error! Bookmark not defined.</b>
Table A-13	Washington Commercial Lodging Market Profile.....	<b>Error! Bookmark not defined.</b>
Table A-14	Washington Commercial Warehouse Market Profile.....	<b>Error! Bookmark not defined.</b>
Table A-15	Washington Commercial Miscellaneous Market Profile .	<b>Error! Bookmark not defined.</b>
Table A-16	Washington Industrial Market Profile.....	<b>Error! Bookmark not defined.</b>
Table A-17	Idaho Residential Single Family Market Profile.....	<b>Error! Bookmark not defined.</b>
Table A-18	Idaho Residential Multi Family Market Profile.....	<b>Error! Bookmark not defined.</b>
Table A-19	Idaho Residential Mobile Home Market Profile .....	<b>Error! Bookmark not defined.</b>
Table A-20	Idaho Residential Low-Income Market Profile.....	<b>Error! Bookmark not defined.</b>
Table A-21	Idaho Commercial Large Office Market Profile .....	<b>Error! Bookmark not defined.</b>
Table A-22	Idaho Commercial Small Office Market Profile.....	<b>Error! Bookmark not defined.</b>
Table A-23	Idaho Commercial Retail Market Profile.....	<b>Error! Bookmark not defined.</b>
Table A-24	Idaho Commercial Restaurant Market Profile.....	<b>Error! Bookmark not defined.</b>
Table A-25	Idaho Commercial Grocery Market Profile.....	<b>Error! Bookmark not defined.</b>
Table A-26	Idaho Commercial Health Market Profile.....	<b>Error! Bookmark not defined.</b>
Table A-27	Idaho Commercial College Market Profile.....	<b>Error! Bookmark not defined.</b>
Table A-28	Idaho Commercial School Market Profile.....	<b>Error! Bookmark not defined.</b>



Table A-29 Idaho Commercial Lodging Market Profile..... **Error! Bookmark not defined.**  
Table A-30 Idaho Commercial Warehouse Market Profile..... **Error! Bookmark not defined.**  
Table A-31 Idaho Commercial Miscellaneous Market Profile..... **Error! Bookmark not defined.**  
Table A-32 Idaho Industrial Market Profile..... **Error! Bookmark not defined.**  
Table D-1 Impacts of HB 1444 on EE Potential..... **Error! Bookmark not defined.**

## 1

## INTRODUCTION

Avista Corporation (Avista) engaged Applied Energy Group (AEG) to conduct a Conservation Potential Assessment (CPA). The CPA is a 20-year study, performed in accordance with Washington Initiative 937 (I-937), that provides data on conservation resources to support development of Avista's 2022 Integrated Resource Plan (IRP). AEG first performed an electric CPA for Avista in 2013, and since then has performed both electric and gas CPAs for Avista's planning cycles to date.

Notable updates to this study from prior CPAs include:

- The base-year for the analysis was brought forward from 2017 to 2019.
- For the residential sector, the study still incorporates Avista's GenPOP residential saturation survey from 2012, which provides a more localized look at Avista's customers than regional surveys. This provided the foundation for the base-year market characterization and energy market profiles. The Northwest Energy Efficiency Alliance's (NEEA's) 2016 Residential Building Stock Assessment (RBSA II) supplemented the GenPOP survey to account for trends in the intervening years.
- For the commercial sector, analysis was performed for the major building types in the service territory. Results from the 2019 Commercial Building Stock Assessment (CBSA), including hospital and university data, provided useful information for this characterization.
- This study also incorporated changes to the list of energy conservation measures, as a result of research by the Regional Technical Forum (RTF). In particular, LED lamps continue to drop in price and provide a significant opportunity for savings even under market transformation assumptions by the RTF.
- Measure characterizations which previously relied on data from the Northwest Power Council's Sventh Power Plan is now updated to the 2021 Power Plan, including measure data, adoption rates, and updated measure applicability.
- The study incorporates updated forecasting assumptions that line up with the most recent Avista load forecast.

Enhancements retained from the 2019 CPA include:

- Analysis of economic potential was excluded from this study. Avista will screen for cost-effective opportunities directly within the IRP model. As such, economic potential and achievable potential have been replaced by a Technical Achievable Potential case.
- In addition to analyzing annual energy savings, the study also estimated the opportunity for reduction of summer and winter peak demand. This involved a full characterization by sector, segment and end use of peak demand in the base year.
- Finally, this year's study included an update to the 2019 assessment of demand-response potential, including analysis of residential programs as well as commercial and industrial (C&I), and options for both summer and winter demand reduction.

Compared to the 2019 Study, 10-year technical achievable potential has increased from 110.1 aMW to 150.3 aMW. This is a net effect of changes in the measure list, market transformation, and baseline growth.

## Abbreviations and Acronyms

Table 1-1 provides a list of abbreviations and acronyms used in this report, along with an explanation.

Table 1-1 Explanation of Abbreviations and Acronyms

Acronym	Explanation
ACS	American Community Survey
AEO	Annual Energy Outlook forecast developed by EIA
AHAM	Association of Home Appliance Manufacturers
AMI	Advanced Metering Infrastructure
AMR	Automated Meter Reading
Auto-DR	Automated Demand Response
B/C Ratio	Benefit to Cost Ratio
BEST	AEG's Building Energy Simulation Tool
C&I	Commercial and Industrial
CAC	Central Air Conditioning
CFL	Compact fluorescent lamp
CPP	Critical Peak Pricing
C&I	Commercial and Industrial
DHW	Domestic Hot Water
DLC	Direct Load Control
DR	Demand Response
DSM	Demand Side Management
EE	Energy Efficiency
EIA	Energy Information Administration
EUL	Estimated Useful Life
EUI	Energy Usage Intensity
FERC	Federal Energy Regulatory Commission
HH	Household
HID	High intensity discharge lamps
HVAC	Heating Ventilation and Air Conditioning
ICAP	Installed Capacity
IOU	Investor Owned Utility
LED	Light emitting diode lamp
LoadMAP	AEG's Load Management Analysis and Planning™ tool
LCOE	Levelized cost of energy

Acronym	Explanation
MW	Megawatt
NPV	Net Present Value
O&M	Operations and Maintenance
PCT	Programmable Communicating Thermostat
RTU	Roof top unit
TRC	Total Resource Cost test
UEC	Unit Energy Consumption



# 2

## ANALYSIS APPROACH AND DATA DEVELOPMENT

This section describes the analysis approach taken for the study and the data sources used to develop the potential estimates.

### Overview of Analysis Approach

To perform the potential analysis, AEG used a bottom-up approach following the major steps listed below. We describe these analysis steps in more detail throughout the remainder of this chapter.

1. Perform a market characterization to describe sector-level electricity use for the residential, commercial, and industrial sectors for the base year, 2019.
2. Develop a baseline projection of energy consumption and peak demand by sector, segment, and end use for 2019 through 2045.
3. Define and characterize several hundred conservation measures to be applied to all sectors, segments, and end uses.
4. Estimate technical and Technical Achievable Potential at the measure level in terms of energy and peak demand impacts from conservation measures for 2019-2045.

### LoadMAP Model

AEG used its Load Management Analysis and Planning tool (LoadMAP™) version 5.0 to develop both the baseline projection and the estimates of potential. AEG developed LoadMAP in 2007 and has enhanced it over time, using it for the EPRI National Potential Study and numerous utility-specific forecasting and potential studies since that time. Built in Excel, the LoadMAP framework (see Figure 2-1) is both accessible and transparent and has the following key features.

- Embodies the basic principles of rigorous end-use models (such as EPRI's REEPS and COMMEND) but in a more simplified, accessible form.
- Includes stock-accounting algorithms that treat older, less efficient appliance/equipment stock separately from newer, more efficient equipment. Equipment is replaced according to the measure life and appliance vintage distributions defined by the user.
- Balances the competing needs of simplicity and robustness by incorporating important modeling details related to equipment saturations, efficiencies, vintage, and the like, where market data are available, and treats end uses separately to account for varying importance and availability of data resources.
- Isolates new construction from existing equipment and buildings and treats purchase decisions for new construction and existing buildings separately.
- Uses a simple logic for appliance and equipment decisions. Other models available for this purpose embody complex decision choice algorithms or diffusion assumptions, and the model parameters tend to be difficult to estimate or observe and sometimes produce anomalous results that require calibration or even overriding. The LoadMAP approach allows the user to drive the appliance and equipment choices year by year directly in the model. This flexible approach allows users to import

the results from diffusion models or to input individual assumptions. The framework also facilitates sensitivity analysis.

- Includes appliance and equipment models customized by end use. For example, the logic for lighting is distinct from refrigerators and freezers.
- Can accommodate various levels of segmentation. Analysis can be performed at the sector level (e.g., total residential) or for customized segments within sectors (e.g., housing type or income level).
- Can incorporate conservation measures, demand-response options, combined heat and power (CHP) and distributed generation options and fuel switching.

Consistent with the segmentation scheme and the market profiles we describe below, the LoadMAP model provides projections of baseline energy use by sector, segment, end use, and technology for existing and new buildings. It also provides forecasts of total energy use and energy-efficiency savings associated with the various types of potential.<sup>1</sup>

Figure 2-1 LoadMAP Analysis Framework

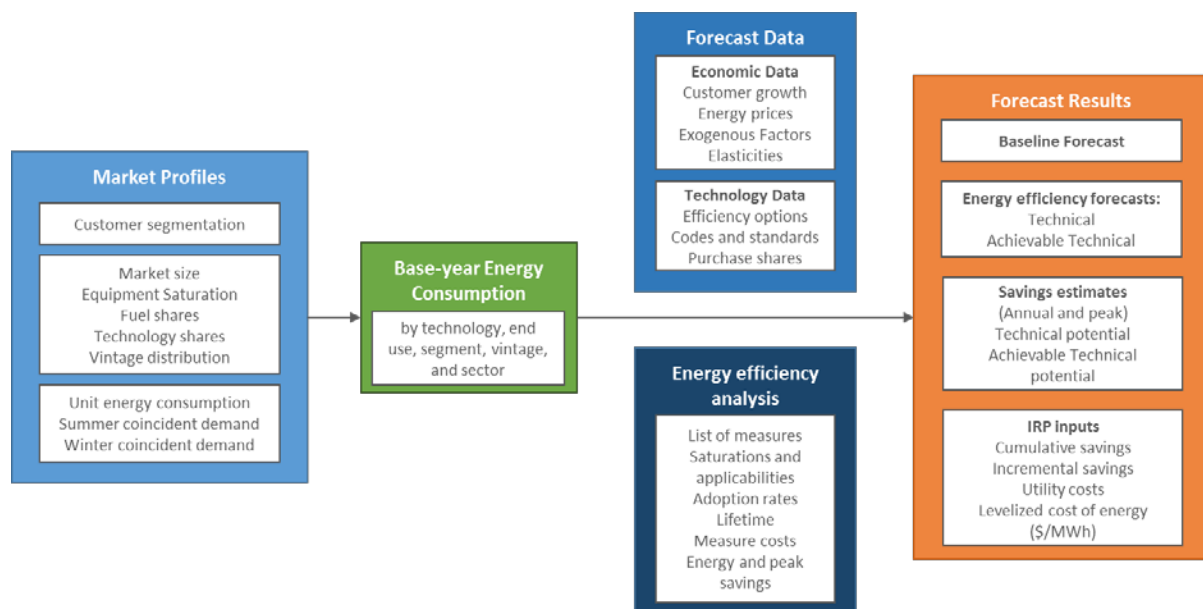

<sup>1</sup> The model computes energy and peak-demand forecasts for each type of potential for each end use as an intermediate calculation. Annual-energy and peak-demand savings are calculated as the difference between the value in the baseline projection and the value in the potential forecast (e.g., the technical potential forecast).

## Definitions of Potential

In this study, the conservation potential estimates represent gross savings developed for two levels of potential: technical potential and Technical Achievable Potential. These levels are described below.

- **Technical Potential** is defined as the theoretical upper limit of conservation potential. It assumes that customers adopt all feasible measures regardless of their cost. At the time of existing equipment failure, customers replace their equipment with the efficient option available. In new construction, customers and developers also choose the most efficient equipment option.
  - In new construction, customers and developers also choose the efficient equipment option relative to applicable codes and standards. Non-equipment measures which may be realistically installed apart from equipment replacements are implemented according to ramp rates developed by the NWPC for its 2021 Power Plan, applied to 100% of the applicable market. This case is a theoretical construct and is provided primarily for planning and informational purposes.
- **Technical Achievable Potential refines** Technical Potential by applying customer participation rates that account for market barriers, customer awareness and attitudes, program maturity, and other factors that may affect market penetration of DSM measures. We used achievability assumptions from the Council's 2021 Power Plan, adjusted for Avista's recent program accomplishments, as the customer adoption rates for this study. For the technical achievable case, ramp rates are applied to between 85%-100% of the applicable market, per Council methodology. This achievability factor represents potential which can reasonably be acquired by all mechanisms available, regardless of how conservation is achieved. Thus, the market applicability assumptions utilized in this study include savings outside of utility programs.<sup>2</sup>
  - Note that in the 2019 CPA, ramp rates used Seventh Plan methodology, which assumed a fixed 85% achievability for all measures. In the 2021 Power Plan, some measures have this limit increased.
  - Details regarding the market adoption factors appear in Appendix B.

## Market Characterization

The first step in the analysis approach is market characterization. In order to estimate the savings potential from energy-efficient measures, it is necessary to understand how much energy is used today and what equipment is currently being used. This characterization begins with a segmentation of Avista's electricity footprint to quantify energy use by sector, segment, end-use application, and the current set of technologies used. We rely primarily on information from Avista, NEEA, and secondary sources as necessary.

### *Segmentation for Modeling Purposes*

The market assessment first defined the market segments (building types, end uses, and other dimensions) that are relevant in the Avista service territory. The segmentation scheme for this project is presented in Table 2-1.

---

<sup>2</sup> Council's 7<sup>th</sup> Power Plan applicability assumptions reference an "Achievable Savings" report published August 1, 2007. <http://www.nwcouncil.org/reports/2007/2007-13/>



Table 2-1 Overview of Avista Analysis Segmentation Scheme

Dimension	Segmentation Variable	Description
1	Sector	Residential, commercial, industrial
2	Segment	<b>Residential:</b> single family, multifamily, manufactured home, low income <b>Commercial:</b> small office, large office, restaurant, retail, grocery, college, school, health, lodging, warehouse, and miscellaneous <b>Industrial:</b> total
3	Vintage	Existing and new construction
4	End uses	Cooling, lighting, water heat, motors, etc. (as appropriate by sector)
5	Appliances/end uses and technologies	Technologies such as lamp type, air conditioning equipment, motors by application, etc.
6	Equipment efficiency levels for new purchases	Baseline and higher-efficiency options as appropriate for each technology

With the segmentation scheme defined, we then performed a high-level market characterization of electricity sales in the base year to allocate sales to each customer segment. We used Avista data and secondary sources to allocate energy use and customers to the various sectors and segments such that the total customer count, energy consumption, and peak demand matched the Avista system totals from 2017 billing data. This information provided control totals at a sector level for calibrating the LoadMAP model to known data for the base-year.

### Market Profiles

The next step was to develop market profiles for each sector, customer segment, end use, and technology. A market profile includes the following elements:

- **Market size** is a representation of the number of customers in the segment. For the residential sector, it is number of households. In the commercial sector, it is floor space measured in square feet. For the industrial sector, it is overall electricity use.
- **Saturations** define the fraction of homes or square feet with the various technologies. (e.g., homes with electric space heating).
- **UEC (unit energy consumption) or EUI (energy-use index)** describes the amount of energy consumed in 2019 by a specific technology in buildings that have the technology. For electricity, UECs are expressed in kWh/household for the residential sector, and EUIs are expressed in kWh/square foot for the commercial sector.
- **Annual Energy Intensity** for the residential sector represents the average energy use for the technology across all homes in 2019. It is computed as the product of the saturation and the UEC and is defined as kWh/household for electricity. For the commercial sector, intensity, computed as the product of the saturation and the EUI, represents the average use for the technology across all floor space in 2019.
- **Annual Usage** is the annual energy use by an end-use technology in the segment. It is the product of the market size and intensity and is quantified in GWh.

- **Peak Demand** for each technology, summer peak and winter peak are calculated using peak fractions of annual energy use from AEG's EnergyShape library and Avista system peak data.
  - The market characterization results, and the market profiles are presented in Chapter 3.

## Baseline Projection

The next step was to develop the baseline projection of annual electricity use and summer peak demand for 2019 through 2045 by customer segment and end use without new utility programs. The end-use projection includes the impacts of relatively certain codes and standards which will unfold over the study timeframe. All such mandates that were defined as of July 2020 are included in the baseline. The baseline projection is the foundation for the analysis of savings from future conservation efforts as well as the metric against which potential savings are measured.

Inputs to the baseline projection include:

- Current economic growth forecasts (i.e., customer growth, income growth)
- Electricity price forecasts
- Trends in fuel shares and equipment saturations
- Existing and approved changes to building codes and equipment standards
- Avista's internally developed sector-level projections for electricity sales

We also developed a baseline projection for summer and winter peak by applying the peak fractions from the energy market profiles to the annual energy forecast in each year.

We present the baseline-projection results for the system as a whole and for each sector in Chapter 4.

### *Washington HB 1444*

While the 2019 CPA was completed before the impacts of HB-1444 could be incorporated, requiring a separate analysis to estimate that impact, this study's foundational setup included assumptions of HB-1444's impact on the available market for energy efficiency measures in Washington.

## Conservation Measure Analysis

This section describes the framework used to assess the savings, costs, and other attributes of conservation measures. These characteristics form the basis for measure-level cost-effectiveness analyses as well as for determining measure-level savings. For all measures, AEG assembled information to reflect equipment performance, incremental costs, and equipment lifetimes. We used this information, along with the Seventh Plan's updated ramp rates to identify technical achievable measure potential.

### *Conservation Measures*

Figure 2-2 outlines the framework for conservation measure analysis. The framework for assessing savings, costs, and other attributes of conservation measures involves identifying the list of measures to include in the analysis, determining their applicability to each market sector and segment, fully characterizing each measure, and calculating the levelized cost of energy (\$/MWh). Potential measures include the replacement of a unit that has failed or is at the end of its useful life with an efficient unit, retrofit or early replacement of equipment, improvements to the building envelope, the application of controls to optimize energy use, and other actions resulting in improved energy efficiency.

We compiled a robust list of conservation measures for each customer sector, drawing upon Avista's measure database, the Regional Technical Forum (RTF), and the Seventh Plan deemed measures database,

as well as a variety of secondary sources. This universal list of conservation measures covers all major types of end-use equipment, as well as devices and actions to reduce energy consumption.

Since an economic screen was not performed in this Study, we have instead calculated the levelized cost of energy (LCOE) for each measure evaluated. This value, expressed in dollars per first-year megawatt hour (MWh) saved, can be used by Avista's IRP model to evaluate cost effectiveness. To calculate a measure's LCOE, first-year measure costs, annual non-energy benefits, and annual operations and maintenance (O&M) costs are levelized over a measure's lifetime, then divided by the first-year savings in MWh. Note that while non-energy benefits are typically included in the numerator of a traditional Total Resource Cost (TRC) economic screen, the LCOE benefits have not been monetized. Therefore, these benefits are instead subtracted from the costs portion of the test. These benefits are not included in the Utility Cost Test (UCT) used in Idaho.

Figure 2-2 Approach for Conservation Measure Assessment

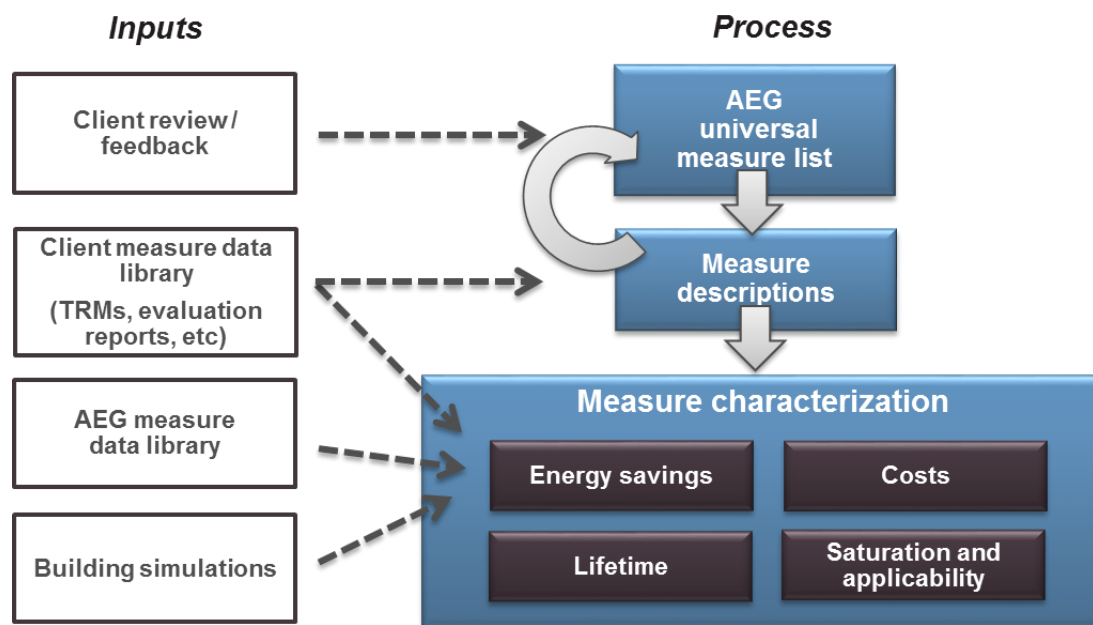

The selected measures are categorized into two types according to the LoadMAP taxonomy: equipment measures and non-equipment measures.

- Equipment measures** are efficient energy-consuming pieces of equipment that save energy by providing the same service with a lower energy requirement than a standard unit. An example is an ENERGY STAR refrigerator that replaces a standard efficiency refrigerator. For equipment measures, many efficiency levels may be available for a given technology, ranging from the baseline unit (often determined by code or standard) up to the most efficient product commercially available. For instance, in the case of central air conditioners, this list begins with the current federal standard SEER 13 unit and spans a broad spectrum up to a maximum efficiency of a SEER 21 unit. The Seventh Plan's "Lost Opportunity" ramp rates are primarily applied to equipment measures.

- **Non-equipment measures** save energy by reducing the need for delivered energy, but do not involve replacement or purchase of major end-use equipment (such as a refrigerator or air conditioner). An example would be a programmable thermostat that is pre-set to run heating and cooling systems only when people are home. Non-equipment measures can apply to more than one end use. For instance, addition of wall insulation will affect the energy use of both space heating and cooling. The Seventh Plan's "Retrofit" ramp rates are primarily applied to no-equipment measures. Non-equipment measures typically fall into one of the following categories:
  - Building shell (windows, insulation, roofing material)
  - Equipment controls (thermostat, compressor staging and controls)
  - Equipment maintenance (cleaning filters, changing setpoints)
  - Whole-building design (building orientation, advanced new construction designs)
  - Lighting retrofits (assumed to be implemented alongside new LEDs at the equipment's normal end of life)
  - Displacement measures (ceiling fan to reduce use of central air conditioners)
  - Commissioning and retrocommissioning (initial or ongoing monitoring of building energy systems to optimize energy use)

We developed a preliminary list of conservation measures, which was distributed to the Avista project team for review. The list was finalized after incorporating comments and is presented in the appendix to this volume.

Once we assembled the list of conservation measures, the project team characterized measure savings, incremental cost, service life, and other performance factors, drawing upon data from the Avista measure database, the Seventh Power Plan, the RTF deemed measure workbooks, simulation modeling, and other well-vetted sources as required.

### Representative Conservation Measure Data Inputs

To provide an example of the conservation measure data, Table 2-2 and Table 2-3 present examples of the detailed data inputs behind both equipment and non-equipment measures, respectively, for the case of residential CAC in single-family homes. Table 2-2 displays the various efficiency levels available as equipment measures, as well as the corresponding useful life, energy usage, and cost estimates. The columns labeled "On Market" and "Off Market" reflect equipment availability due to codes and standards or the entry of new products to the market. Note that in this example no standards come into play and therefore all options are available throughout the forecast.

Table 2-2 Example Equipment Measures for Central AC – Single-Family Home

Efficiency Level	Useful Life (yrs)	Equipment Cost	Energy Usage (kWh/yr)	On Market	Off Market
SEER 13.0	10 to 20	\$2,097	1,383	2019	n/a
SEER 14.0	10 to 20	\$2,505	1,284	2019	n/a
SEER 15.0	10 to 20	\$2,913	1,199	2019	n/a
SEER 16.0	10 to 20	\$3,321	1,124	2019	n/a
SEER 18.0	10 to 20	\$4,140	999	2019	n/a
SEER 20.0	10 to 20	\$4,955	899	2019	n/a

Table 2-3 lists some of the non-equipment measures applicable to a CAC in an existing single family home. LCOE values for all measures are evaluated based on the lifetime costs of the measure divided by the first-year savings. The total costs and savings are calculated for each year of the study and depend on the base year saturation of the measure, the applicability<sup>3</sup> of the measure, and the savings as a percentage of the relevant energy end uses.

Table 2-3 Example Non-Equipment Measures – Single Family Home, Existing

End Use	Measure	Saturation in 2019	Applicability	Lifetime (yrs)	Measure Installed Cost	Energy Savings (%)
Cooling	Insulation - Ceiling Installation	0%	10%	45	\$2,084	21.8%
Cooling	Insulation - Wall Cavity Installation	0%	10%	45	\$4,374	3.5%
Cooling	Windows - High Efficiency/ENERGY STAR	0%	95%	45	\$4,421	7.1%
Cooling	Thermostat – Connected	14%	70%	5	\$265.00	6.0%

Table 2-4 summarizes the number of measures evaluated for each segment within each sector.

Table 2-4 Number of Measures Evaluated

Sector	Total Measures	Measure Permutations w/ 2 Vintages	Measure Permutations w/ Segments
Residential	88	176	704
Commercial	130	260	2,860
Industrial	111	222	222
<b>Total Measures Evaluated</b>	<b>329</b>	<b>658</b>	<b>3,786</b>

<sup>3</sup> The applicability factors take into account whether the measure is applicable to a particular building type and whether it is feasible to install the measure. For instance, attic fans are not applicable to homes where there is insufficient space in the attic or there is no attic at all.

## Conservation Potential

The approach we used for this study to calculate the conservation potential adheres to the approaches and conventions outlined in the National Action Plan for Energy-Efficiency (NAPEE) Guide for Conducting Potential Studies (November 2007).<sup>4</sup> The NAPEE Guide represents the most credible and comprehensive industry practice for specifying conservation potential. As described in Chapter 2, two types of potential were developed as part of this effort: Technical Potential and Technical Achievable Potential.

- **Technical potential** is a theoretical construct that assumes the highest efficiency measures that are technically feasible to install are adopted by customers, regardless of cost or customer preferences. Thus, determining the technical potential is relatively straightforward. LoadMAP “chooses” the efficient equipment options for each technology at the time of equipment replacement. In addition, it installs all relevant non-equipment measures for each technology to calculate savings. LoadMAP applies the savings due to the non-equipment measures one-by-one to avoid double counting of savings. The measures are evaluated in order of their LCOE ratio, with the measure with the lowest LCOE values (most likely to be cost effective) applied first. Each time a measure is applied, the baseline energy use for the end use is reduced and the percentage savings for the next measure is applied to the revised (lower) usage.
- **Technical Achievable Potential** refines Technical Potential by applying market adoption rates for each measure that estimate the percentage of customers who would be likely to select each measure, given consumer preferences (partially a function of incentive levels), retail energy rates, imperfect information, and real market barriers and conditions. These barriers tend to vary, depending on the customer sector, local energy market conditions, and other, hard-to-quantify factors. In addition to utility-sponsored programs, alternative acquisition methods, such as improved codes and standards and market transformation, can be used to capture portions of these resources, and are included within the Technical Achievable Potential, per 2021 Power Plan methodology.

The calculation of Technical Potential is a straightforward algorithm. To develop estimates for Technical Achievable Potential, we develop market adoption rates for each measure that specify the percentage of customers that will select the highest-efficiency economic option. With the beginning of a new power plan, technical achievable potential aligns with ramp assignments from the 2021 Power Plan. Over time, measure adoption increases from the starting point up to 85% or more, to model increasing market acceptance and program improvements. For measures within the 2021 Power Plan, the Council’s prescribed ramp rates were used. For measures outside the 2021 Plan, AEG assigned ramp rates comparable to similar measures within the 2021 Plan. The market adoption rates for each measure appear in Appendix B.

Results of all the potentials analysis are presented in Chapter 5.

## Data Development

This section details the data sources used in this study, followed by a discussion of how these sources were applied. In general, data sources were applied in the following order: Avista data, Northwest data, and well-vetted national or other regional secondary sources.

### Data Sources

The data sources are organized into the following categories:

---

<sup>4</sup> National Action Plan for Energy Efficiency (2007). *National Action Plan for Energy Efficiency Vision for 2025: Developing a Framework for Change*. [www.epa.gov/eeactionplan](http://www.epa.gov/eeactionplan).

- Avista data
- Northwest Energy Efficiency Alliance data
- Northwest Power and Conservation Council data
- AEG's databases and analysis tools
- Other secondary data and reports

### **Avista Data**

Our highest priority data sources for this study were those that were specific to Avista.

- **Avista customer data:** Avista provided billing data for development of customer counts and energy use for each sector. We also used the results of the Avista GenPOP survey, a residential saturation survey.
- **Load forecasts:** Avista provided an economic growth forecast by sector; electric load forecast; peak-demand forecasts at the sector level; and retail electricity price history and forecasts.
- **Economic information:** Avista Power provided a discount rate and line loss factor. Avoided costs were not provided due to the economic screen being moved to the IRP model.
- **Avista program data:** Avista provided information about past and current programs, including program descriptions, goals, and achievements to date.

### **Northwest Energy Efficiency Alliance Data**

The Northwest Energy Efficiency Alliance conducts research on an ongoing basis for the Northwest region. The following studies were particularly useful for this study:

- **Northwest Energy Efficiency Alliance, Residential Building Stock Assessment II, Single-Family Homes Report 2016-2017,** <https://neea.org/img/uploads/Residential-Building-Stock-Assessment-II-Single-Family-Homes-Report-2016-2017.pdf>
- **Northwest Energy Efficiency Alliance, Residential Building Stock Assessment II, Manufactured Homes Report 2016-2017,** <https://neea.org/img/uploads/Residential-Building-Stock-Assessment-II-Manufactured-Homes-Report-2016-2017.pdf>
- **Northwest Energy Efficiency Alliance, Residential Building Stock Assessment II, Multifamily Buildings Report 2016-2017,** <https://neea.org/img/documents/Residential-Building-Stock-Assessment-II-Multifamily-Homes-Report-2016-2017.pdf>
- **Northwest Energy Efficiency Alliance, 2019 Commercial Building Stock Assessment,** May 21, 2020, <https://neea.org/resources/cbsa-4-2019-final-report>
- **Northwest Energy Efficiency Alliance, 2014 Industrial Facilities Site Assessment,** December 29, 2014, <http://neea.org/docs/default-source/reports/2014-industrial-facilities-stock-assessment-final-report.pdf?sfvrsn=6>

### **Northwest Power and Conservation Council Data**

Several sources of data were used to characterize the conservation measures. We used the following regional data sources and supplemented with AEG's data sources to fill in any gaps.

- **Regional Technical Forum Deemed Measures.** The NWPCC Regional Technical Forum maintains databases of deemed measure savings data, available at <http://www.nwcouncil.org/energy/rtf/measures/Default.asp>.
- **Northwest Power and Conservation Council 2021 Power Plan Conservation Supply Curve Workbooks.** To develop its 2021 Power Plan, the Council used workbooks with detailed information about measures, available at <https://nwcouncil.box.com/s/u0dgjxkoxoj2tttym81uka3wrjcy6bo6>
- **Northwest Power and Conservation Council, MC and Loadshape File,** September 29, 2016. The Council's load shape library was utilized to convert CPA results into hourly conservation impacts for use in Avista's IRP process. Generalized Least Square (GLS) versions of these load shapes are available at <https://nwcouncil.app.box.com/s/gacr21z8i89hh8ppk11rdzgm6fz4xlz3>

## AEG Data

AEG maintains several databases and modeling tools that we use for forecasting and potential studies. Relevant data from these tools has been incorporated into the analysis and deliverables for this study.

- **AEG Energy Market Profiles:** For more than 10 years, AEG staff has maintained profiles of end-use consumption for the residential, commercial, and industrial sectors. These profiles include market size, fuel shares, unit consumption estimates, and annual energy use by fuel (electricity and natural gas), customer segment and end use for 10 regions in the U.S. The Energy Information Administration surveys (RECS, CBECS and MECS) as well as state-level statistics and local customer research provide the foundation for these regional profiles.
- **Building Energy Simulation Tool (BEST).** AEG's BEST is a derivative of the DOE 2.2 building simulation model, used to estimate base-year UECs and EUIs, as well as measure savings for the HVAC-related measures.
- **AEG's EnergyShape™:** AEG's load shape database was used in addition to the Council's load shape database for comparative purposes. This database of load shapes includes the following:
  - Residential – electric load shapes for ten regions, three housing types, 13 end uses
  - Commercial – electric load shapes for nine regions, 54 building types, ten end uses
  - Industrial – electric load shapes, whole facility only, 19 2-digit SIC codes, as well as various 3-digit and 4-digit SIC codes
- **AEG's Database of Energy Efficiency Measures (DEEM):** AEG maintains an extensive database of measure data for our studies. Our database draws upon reliable sources including the California Database for Energy Efficient Resources (DEER), the EIA Technology Forecast Updates – Residential and Commercial Building Technologies – Reference Case, RS Means cost data, and Grainger Catalog Cost data.
- **Recent studies.** AEG has conducted numerous studies of EE potential in the last five years. We checked our input assumptions and analysis results against the results from these other studies, which include Tacoma Power, Idaho Power, PacifiCorp, Ameren Missouri, Vectren Energy, Indianapolis Power & Light, Tennessee Valley Authority, Ameren Missouri, Ameren Illinois, and Seattle City Light. In



addition, we used the information about impacts of building codes and appliance standards from recent reports for the Edison Electric Institute<sup>5</sup>.

## Other Secondary Data and Reports

Finally, a variety of secondary data sources and reports were used for this study. The main sources are identified below.

- **Annual Energy Outlook.** The Annual Energy Outlook (AEO), conducted each year by the U.S. Energy Information Administration (EIA), presents yearly projections and analysis of energy topics. For this study, we used data from the 2019 AEO.
- **Local Weather Data:** Weather from NOAA's National Climatic Data Center for Spokane, WA was used as the basis for building simulations.
- **EPRI End-Use Models (REEPS and COMMEND).** These models provide the elasticities we apply to electricity prices, household income, home size and heating and cooling.
- **Database for Energy Efficient Resources (DEER).** The California Energy Commission and California Public Utilities Commission (CPUC) sponsor this database, which is designed to provide well-documented estimates of energy and peak demand savings values, measure costs, and effective useful life (EUL) for the state of California. We used the DEER database to cross check the measure savings we developed using BEST and DEEM.
- **Other relevant regional sources:** These include reports from the Consortium for Energy Efficiency (CEE), the Environmental Protection Agency (EPA), and the American Council for an Energy-Efficient Economy (ACEEE).

## Data Application

We now discuss how the data sources described above were used for each step of the study.

### Data Application for Market Characterization

To construct the high-level market characterization of electricity use and households/floor space for the residential, commercial and industrial sectors, we used Avista billing data and customer surveys to estimate energy use.

- For the residential sector, Avista estimated the numbers of customers and the average energy use per customer for each of the three segments, based on its GenPOP survey, matched to billing data for surveyed customers. AEG compared the resulting segmentation with data from the American Community Survey (ACS) regarding housing types and income and found that the Avista segmentation corresponded well with the ACS data. (See Chapter 3 for additional details.)
- To segment the commercial and industrial segments, we relied upon the allocation from the previous energy efficiency potential study. For the previous study, customers and sales were allocated to

- 
- <sup>5</sup> AEG staff has prepared three white papers on the topic of factors that affect U.S. electricity consumption, including appliance standards and building codes. Links to all three white papers are provided:
    - [http://www.edisonfoundation.net/IEE/Documents/IEE\\_RohmundApplianceStandardsEfficiencyCodes1209.pdf](http://www.edisonfoundation.net/IEE/Documents/IEE_RohmundApplianceStandardsEfficiencyCodes1209.pdf)
    - [http://www.edisonfoundation.net/iee/Documents/IEE\\_CodesandStandardsAssessment\\_2010-2025\\_UPDATE.pdf](http://www.edisonfoundation.net/iee/Documents/IEE_CodesandStandardsAssessment_2010-2025_UPDATE.pdf).
    - [http://www.edisonfoundation.net/iee/Documents/IEE\\_FactorsAffectingUSElecConsumption\\_Final.pdf](http://www.edisonfoundation.net/iee/Documents/IEE_FactorsAffectingUSElecConsumption_Final.pdf)

building type based on SIC codes, with some adjustments between the commercial and industrial sectors to better group energy use by facility type and predominate end uses. (See Chapter 3 for additional details.)

### Data Application for Market Profiles

The specific data elements for the market profiles, together with the key data sources, are shown in Table 2-5. To develop the market profiles for each segment, we did the following:

1. Developed control totals for each segment. These include market size, segment-level annual electricity use, and annual intensity.
2. Used the Avista GenPOP Survey, NEEA's RBSA, NEEA's CBSA, NEEA's IFSA, and AEG's Energy Market Profiles database to develop existing appliance saturations, appliance and equipment characteristics, and building characteristics.
3. Ensured calibration to control totals for annual electricity sales in each sector and segment.
4. Compared and cross-checked with other recent AEG studies.
5. Worked with Avista staff to vet the data against their knowledge and experience.

### Data Application for Baseline Projection

Table 2-5 summarizes the LoadMAP model inputs required for the baseline projection. These inputs are required for each segment within each sector, as well as for new construction and existing dwellings/buildings.

Table 2-5 Data Applied for the Market Profiles

Model Inputs	Description	Key Sources
Market size	Base-year residential dwellings, commercial floor space, and industrial employment	Avista billing data Avista GenPOP Survey NEEA RBSA and CBSA AEO 2019
Annual intensity	<b>Residential:</b> Annual use per household <b>Commercial:</b> Annual use per square foot <b>Industrial:</b> Annual use per employee	Avista billing data AEG's Energy Market Profiles NEEA RBSA and CBSA AEO 2019 Other recent studies
Appliance/equipment saturations	Fraction of dwellings with an appliance/technology Percentage of C&I floor space/employment with equipment/technology	Avista GenPOP Survey NEEA RBSA and CBSA AEG's Energy Market Profiles
UEC/EUI for each end-use technology	UEC: Annual electricity use in homes and buildings that have the technology EUI: Annual electricity use per square foot/employee for a technology in floor space that has the technology	NWPCC RTF and Seventh Plan and RTF HVAC uses: BEST simulations using prototypes developed for Idaho Engineering analysis DEEM Recent AEG studies
Appliance/equipment age distribution	Age distribution for each technology	RTF and NWPCC Seventh Plan data NEEA regional survey data Utility saturation surveys Recent AEG studies
Efficiency options for each technology	List of available efficiency options and annual energy use for each technology	AEG DEEM AEO 2019 DEER RTF and NWPCC 2021 Plan data Previous studies
Peak factors	Share of technology energy use that occurs during the peak hour	EnergyShape database

Table 2-6 Data Needs for the Baseline Projection and Potentials Estimation in LoadMAP

Model Inputs	Description	Key Sources
Customer growth forecasts	Forecasts of new construction in residential and C&I sectors	Avista load forecast AEO 2019 economic growth forecast
Equipment purchase shares for baseline projection	For each equipment/technology, purchase shares for each efficiency level; specified separately for existing equipment replacement and new construction	Shipments data from AEO and ENERGY STAR AEO 2019 regional forecast assumptions <sup>6</sup> Appliance/efficiency standards analysis Avista program results and evaluation reports
Utilization model parameters	Price elasticities, elasticities for other variables (income, weather)	EPRI's REEPS and COMMEND models AEO 2019

In addition, we implemented assumptions for known future equipment standards as of September 2018, as shown in Table 2-6, Table 2-7 and Table 2-8. The assumptions tables here extend through 2025, after which all standards are assumed to hold steady.

<sup>6</sup> We developed baseline purchase decisions using the Energy Information Agency's *Annual Energy Outlook* report (2016), which utilizes the National Energy Modeling System (NEMS) to produce a self-consistent supply and demand economic model. We calibrated equipment purchase options to match manufacturer shipment data for recent years and then held values constant for the study period. This removes any effects of naturally occurring conservation or effects of future EE programs that may be embedded in the AEO forecasts.

Table 2-7 Residential Electric Equipment Standards<sup>7</sup>

End Use	Technology	2019	2020	2021	2022	2023	2024	2025
Cooling	Central AC			SEER 13.0				
	Room AC			EER 10.8				
Cooling/ Heating	Air-Source Heat Pump		SEER 13.0 / HSPF 8.2				SEER 14.0 / HSPF 9.0	
Water Heating	Water Heater (≤55 gallons)			EF 0.95				
	Water Heater (>55 gallons)			EF 2.0 (Heat Pump Water Heater)				
Lighting	General Service		Advanced Incandescent (~20 lumens/watt)		Advanced Incandescent (~45 lumens/watt)			
	Linear Fluorescent				T8 (92.5 lm/W lamp)			
Appliances	Refrigerator			25% more efficient than the 1997 Final Rule (62 FR 23102)				
	Freezer							
	Clothes Washer		IMEF 1.84 / WF 4.7					
	Clothes Dryer		3.73 Combined EF					
Miscellaneous	Furnace Fans	ECM	ECM					

<sup>7</sup> The assumptions tables here extend through 2025, after which all standards are assumed to hold steady.

Table 2-8 Commercial Electric Equipment Standards<sup>8</sup>

End Use	Technology	2019	2020	2021	2022	2023	2024	2025
Cooling	Chillers	2007 ASHRAE 90.1						
	RTUs	EER 11.9/11.2						
	PTAC	EER 9.8	EER 11.0					
Cooling/ Heating	Heat Pump	EER 11.0/ COP 3.3	EER 11.4/ COP 3.3					
	PTHP	EER 10.4/COP 3.1						
Ventilation	All	Constant Air Volume/Variable Air Volume						
Lighting	General Service	Advanced Incandescent (~20 lumens/watt)	Advanced Incandescent (~45 lumens/watt)					
	Linear Lighting	T8 (82.5 lm/W lamp)						
	High Bay	51.2 lm/W	Metal Halide (55.6 lm/W)					
Refrigeration	Walk-In	COP 3.2	COP 6.1					
	Reach-In	32 kWh/sqft						
	Glass Door	12-28% more efficient than EPACT 2005						
	Open Display	1,537 kWh/ft	1,453 kWh/ft					
	Icemaker	6.1 kWh/100 lbs.						
Food Service	Pre-Rinse	1.6 GPM	1.0 GPM					
Motors	All	Expanded EISA 2007						

<sup>8</sup> The assumptions tables here extend through 2025, after which all standards are assumed to hold steady.

Table 2-9 Industrial Electric Equipment Standards<sup>9</sup>

End Use	Technology	2019	2020	2021	2022	2023	2024	2025
Cooling	Chillers	2007 ASHRAE 90.1						
	RTUs	EER 11.9/11.2						
	PTAC	EER 9.8			EER 11.0			
Cooling/ Heating	Heat Pump	EER 11.0/ COP 3.3		EER 11.4/ COP 3.3				
	PTHP	EER 10.4/COP 3.1						
Ventilation	All	Constant Air Volume/Variable Air Volume						
Lighting	General Service	Advanced Incandescent (~20 lumens/watt)		Advanced Incandescent (~45 lumens/watt)				
		T8 (82.5 lm/W lamp)						
	High Bay	51.2 lm/W		Metal Halide (55.6 lm/W)				
Motors	All	Expanded EISA 2007						

<sup>9</sup> The assumptions tables here extend through 2025, after which all standards are assumed to hold steady.

## Conservation Measure Data Application

Table 2-9 details the energy-efficiency data inputs to the LoadMAP model. It describes each input and identifies the key sources used in the Avista analysis.

Table 2-10 Data Needs for the Measure Characteristics in LoadMAP

Model Inputs	Description	Key Sources
Energy Impacts	The annual reduction in consumption attributable to each specific measure. Savings were developed as a percentage of the energy end use that the measure affects.	Avista measure data NWPCC workbooks, RTF NWPCC Seventh Plan conservation workbooks BEST AEG DEEM AEO 2019 DEER Other secondary sources
Peak Demand Impacts	Savings during the peak demand periods are specified for each electric measure. These impacts relate to the energy savings and depend on the extent to which each measure is coincident with the system peak.	Avista measure data BEST AEG DEEM EnergyShape
Costs	Equipment Measures: Includes the full cost of purchasing and installing the equipment on a per-household, per-square-foot, per employee or per service point basis for the residential, commercial, and industrial sectors, respectively. Non-equipment measures: Existing buildings – full installed cost. New Construction - the costs may be either the full cost of the measure, or as appropriate, it may be the incremental cost of upgrading from a standard level to a higher efficiency level.	Avista measure data NWPCC workbooks, RTF NWPCC 2021 Plan conservation workbooks AEG DEEM AEO 2019 DEER RS Means Other secondary sources
Measure Lifetimes	Estimates derived from the technical data and secondary data sources that support the measure demand and energy savings analysis.	Avista measure data NWPCC workbooks, RTF NWPCC 2021 Plan conservation workbooks AEG DEEM AEO 2019 DEER Other secondary sources
Applicability	Estimate of the percentage of dwellings in the residential sector, square feet in the commercial sector, or employees in the industrial sector where the measure is applicable and where it is technically feasible to implement.	Avista measure data NWPCC workbooks, RTF NWPCC 2021 Plan conservation workbooks AEG DEEM DEER Other secondary sources



On Market and Off  
Market Availability

Expressed as years for equipment measures to reflect when the equipment technology is available or no longer available in the market.

AEG appliance standards and building codes analysis

## Data Application for Technical Achievable Potential

To estimate Technical Achievable Potential, two sets of parameters are needed to represent customer decision making behavior with respect to energy-efficiency choices.

- Technical diffusion curves for non-equipment measures.** Equipment measures are installed when existing units fail. Non-equipment measures do not have this natural periodicity, so rather than installing all available non-equipment measures in the first year of the projection (instantaneous potential), they are phased in according to adoption schedules that generally align with the diffusion of similar equipment measures. Like the 2019 CPA, we applied the “Retrofit” ramp rates from the 2021 Power Plan directly as diffusion curves. For technical potential, these rates summed up to 100% by the 20<sup>th</sup> year for all measures.
- Adoption rates.** Customer adoption rates or take rates are applied to technical potential to estimate Technical Achievable Potential. For equipment measures, the Council’s “Lost Opportunity” ramp rates were applied to technical potential with a maximum achievability of 85%-100% depending on the measure. For non-equipment measures, the Council’s “Retrofit” ramp rates have already been applied to calculate technical diffusion. In this case, we multiply each of these by 85% (for most measures) to calculate Technical Achievable Potential. Adoption rates are presented in Appendix B.

# 3

## MARKET CHARACTERIZATION AND MARKET PROFILES

In this section, we describe how customers in the Avista service territory use electricity in the base year of the study, 2019. It begins with a high-level summary of energy use across all sectors and then delves into each sector in more detail.

### Energy Use Summary

Total electricity use for the residential, commercial, and industrial sectors for Avista in 2019 was 7,794 GWh; 5,205 GWh (WA) and 2,589 GWh (ID). As shown in the tables below, in both states the residential sector accounts for nearly 50% of annual energy use, followed by commercial at around 40% of annual energy use. In terms of winter peak demand, the total system peak in 2019 was 1,530 MW: 1,060 (WA) and 470 MW (ID). In both states, the residential sector contributes the most to the winter peak.

Figure 3-1 Sector-Level Electricity Use in Base Year 2019, Washington

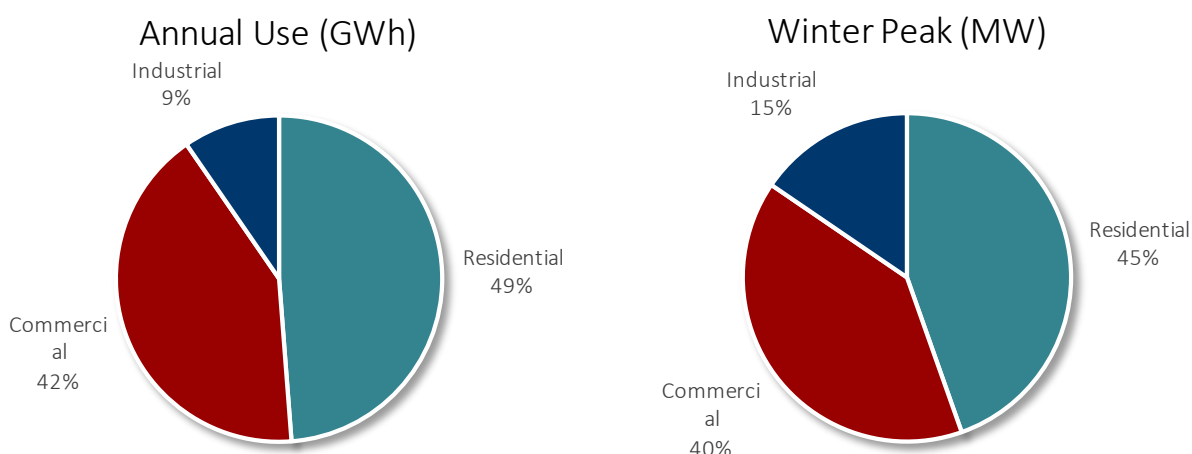

Table 3-1 Avista Sector Control Totals (2019), Washington

Sector	Annual Electricity Use (GWh)	% of Annual Use	Winter Peak Demand (MW)	% of Winter Peak
Residential	2,539	49%	473	45%
Commercial	2,166	42%	423	40%
Industrial	500	10%	164	15%
<b>Total</b>	<b>5,205</b>	<b>100%</b>	<b>1,060</b>	<b>100%</b>

Figure 3-2 Sector-Level Electricity Use in Base Year 2019, Idaho

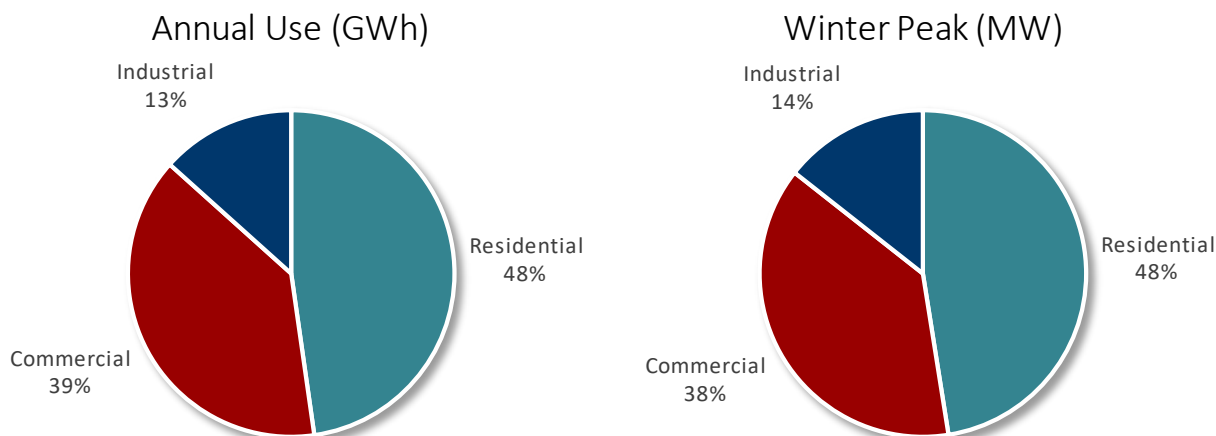

Table 3-2 Avista Sector Control Totals (2019), Idaho

Sector	Annual Electricity Use (GWh)	% of Annual Use	Winter Peak Demand (MW)	% of Winter Peak
Residential	1,236	48%	223	47%
Commercial	1,007	39%	179	38%
Industrial	346	13%	68	14%
<b>Total</b>	<b>2,589</b>	<b>100%</b>	<b>470</b>	<b>100%</b>

## Residential Sector

The total number of households and electricity sales for the service territory were obtained from Avista's customer database. In 2019, there were 229,171 households in the state of Washington that used a total of 2,539 GWh with winter peak demand of 473 MW. Average use per customer (or household) at 11,080 kWh is about average compared to other regions of the country. We allocated these totals into four residential segments and the values are shown in Table 3-3.

Table 3-4 shows the total number of households and electricity sales in the state of Idaho. In 2019, there were 116,114 households that used a total of 1,236 GWh with winter peak demand of 223 MW. Average use per customer (or household) was 10,643 kWh.

Table 3-3 Residential Sector Control Totals (2019), Washington

Segment	Number of Customers	Electricity Use	% of Annual	Annual Use/Customer (kWh/HH)	Winter Peak
Single Family	139,336	1,778	70%	12,760	330
Multifamily	12,834	98	4%	7,656	18
Mobile Home	8,250	95	4%	11,484	18
Low Income	68,751	568	22%	8,266	107
<b>Total</b>	<b>229,171</b>	<b>2,539</b>	<b>100%</b>	<b>11,080</b>	<b>473</b>

Table 3-4 Residential Sector Control Totals (2019), Idaho

Segment	Number of Customers	Electricity Use	% of Annual	Annual Use/Customer (kWh/HH)	Winter Peak
Single Family	70,597	863	70%	12,224	154
Multifamily	5,690	42	3%	7,326	7
Mobile Home	5,225	57	5%	10,989	10
Low Income	34,602	274	22%	7,910	51
<b>Total</b>	<b>116,114</b>	<b>1,236</b>	<b>100%</b>	<b>10,643</b>	<b>223</b>

As we describe in the previous chapter, the market profiles provide the foundation for development of the baseline projection and the potential estimates. The average market profile for the residential sector is presented in Table 3-5 (WA) and Table 3-6 (ID). Segment-specific market profiles are presented in Appendix A.

Figure 3-3 (WA) and Figure 3-4 (ID) show the distribution of annual electricity use by end use for all customers. Two main electricity end uses—appliances and space heating—account for approximately 55% of total use. Appliances include refrigerators, freezers, stoves, clothes washers, clothes dryers, dishwashers, and microwaves. The remainder of the energy falls into the water heating, lighting, cooling, electronics, and the miscellaneous category – which is comprised of furnace fans, pool pumps, electric vehicles, and other “plug” loads (all other usage not covered by those listed in Table 3-5 and Table 3-6 such as hair dryers, power tools, coffee makers, etc.).

The charts also show estimates of winter peak demand by end use. As expected, heating is the largest contributor to winter peak demand, followed by appliances, lighting, and water heating.

Figure 3-5 (WA) and Figure 3-6 (ID) present the electricity intensities by end use and housing type. Single family homes have the highest use per customer at 11,699 kWh/year (WA) and 11,158 kWh/year (ID).

Figure 3-3 Residential Electricity Use and Winter Peak Demand by End Use (2019), Washington

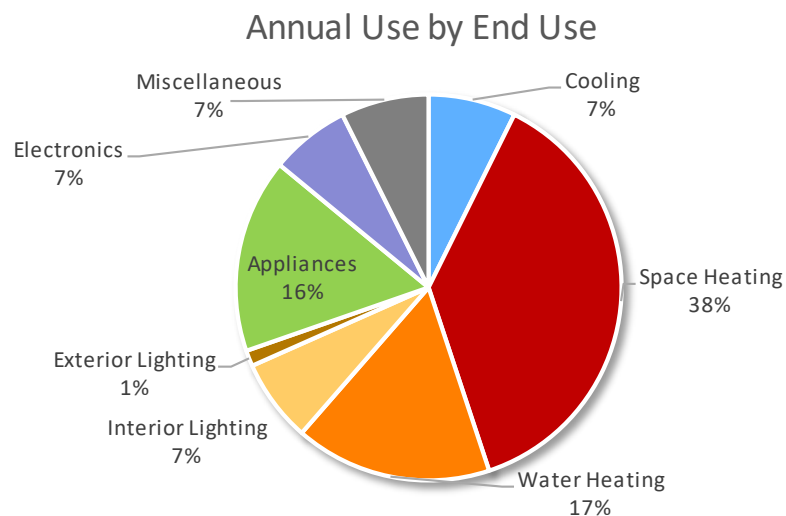

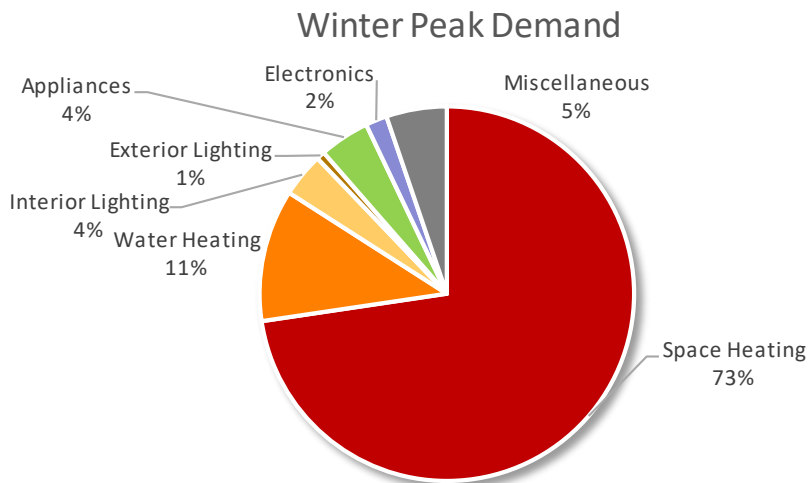
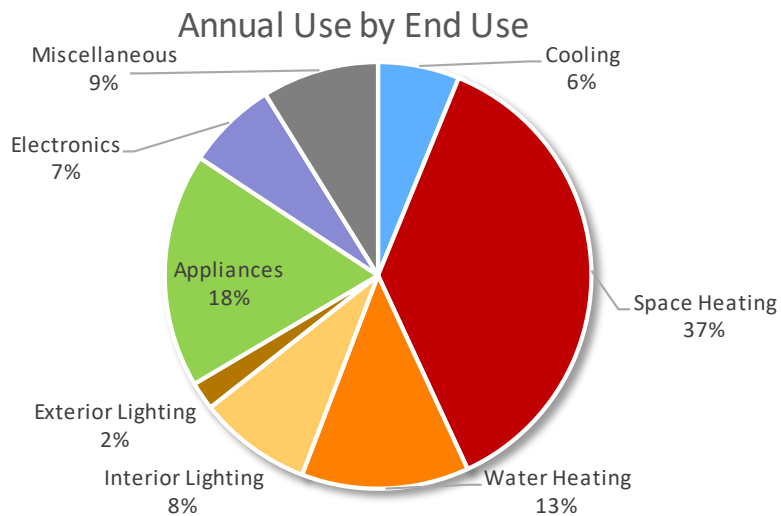

Figure 3-4 Residential Electricity Use and Winter Peak Demand by End Use (2019), Idaho



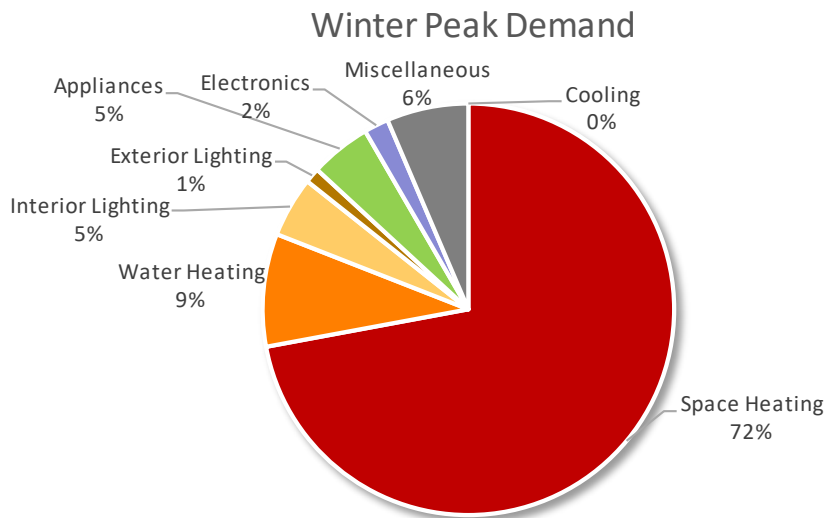

Figure 3-5 Residential Intensity by End Use and Segment (Annual kWh/HH, 2019), Washington

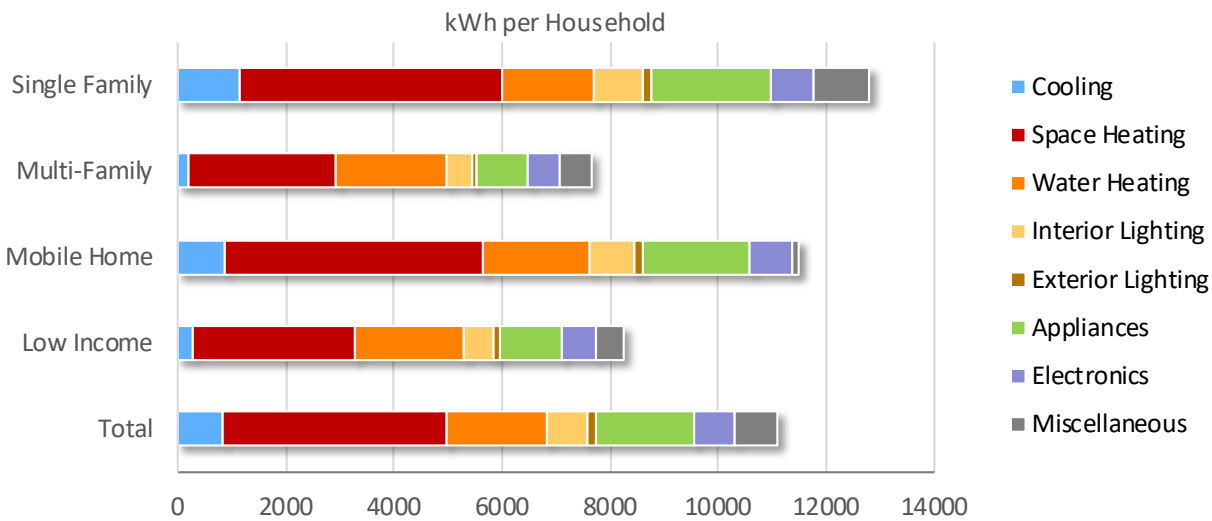

Figure 3-6 Residential Intensity by End Use and Segment (Annual kWh/HH, 2019), Idaho

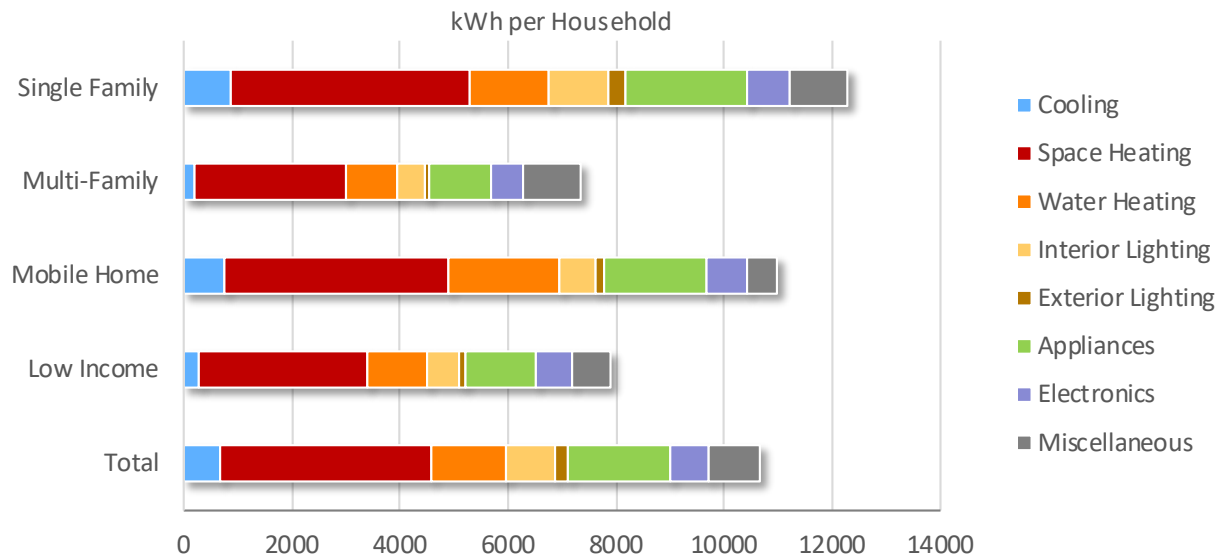

Table 3-5 Average Market Profile for the Residential Sector, 2019, Washington

End Use	Technology	Saturation	EUI (kWh)	Intensity (kWh/HH)	Usage (MWh)
Cooling	Central AC	23.7%	1,396	331	75,859
Cooling	Room AC	21.3%	307	65	15,008
Cooling	Air-Source Heat Pump	24.1%	1,611	388	88,988
Cooling	Geothermal Heat Pump	1.6%	1,737	28	6,355
Cooling	Evaporative AC	1.2%	163	2	448
Space Heating	Electric Room Heat	25.8%	4,478	1,153	264,334
Space Heating	Electric Furnace	8.8%	9,062	794	182,039
Space Heating	Air-Source Heat Pump	24.1%	7,030	1,695	388,343
Space Heating	Geothermal Heat Pump	1.6%	3,627	58	13,267
Space Heating	Secondary Heating	65.2%	724	472	108,184
Water Heating	Water Heater <= 55 Gal	61.1%	2,816	1,720	394,122
Water Heating	Water Heater > 55 Gal	3.7%	3,006	112	25,582
Interior Lighting	General Service Lighting	100.0%	443	443	101,528
Interior Lighting	Linear Lighting	100.0%	105	105	23,961
Interior Lighting	Exempted Lighting	100.0%	223	223	51,103
Exterior Lighting	Lighting	100.0%	147	147	33,657
Appliances	Clothes Washer	78.0%	104	81	18,656
Appliances	Clothes Dryer	72.3%	756	546	125,139
Appliances	Dishwasher	76.9%	85	65	15,006
Appliances	Refrigerator	98.8%	520	513	117,677
Appliances	Freezer	34.3%	460	158	36,171
Appliances	Second Refrigerator	22.9%	816	187	42,805
Appliances	Stove/Oven	90.8%	165	150	34,370
Appliances	Microwave	94.8%	113	108	24,655
Electronics	Personal Computers	50.1%	146	73	16,774
Electronics	Monitor	93.2%	58	54	12,299
Electronics	Laptops	39.9%	38	15	3,472
Electronics	TVs	190.7%	100	191	43,848
Electronics	Printer/Fax/Copier	46.2%	40	19	4,262
Electronics	Set-top Boxes/DVRs	153.8%	95	146	33,360
Electronics	Devices and Gadgets	100.0%	243	243	55,706
Miscellaneous	Electric Vehicles	0.5%	3,153	16	3,641
Miscellaneous	Pool Pump	1.1%	1,313	14	3,185
Miscellaneous	Pool Heater	1.1%	3,517	37	8,592
Miscellaneous	Hot Tub / Spa	8.8%	1,468	130	29,679
Miscellaneous	Furnace Fan	50.1%	201	100	23,030
Miscellaneous	Well pump	2.4%	551	14	3,094
Miscellaneous	Miscellaneous	100.0%	507	507	116,158
Generation	Solar PV	0.3%	-7,809	-23	-5,183
<b>Total</b>				<b>11,080</b>	<b>2,539,174</b>



Table 3-6 Average Market Profile for the Residential Sector, 2019, Idaho

End Use	Technology	Saturation	EUI (kWh)	Intensity (kWh/HH)	Usage (MWh)
Cooling	Central AC	28.9%	1,405	406	47,107
Cooling	Room AC	16.6%	364	61	7,025
Cooling	Air-Source Heat Pump	11.8%	1,529	181	21,029
Cooling	Geothermal Heat Pump	0.5%	1,743	9	1,063
Cooling	Evaporative AC	1.5%	157	2	282
Space Heating	Electric Room Heat	23.2%	6,008	1,391	161,557
Space Heating	Electric Furnace	11.1%	8,590	953	110,663
Space Heating	Air-Source Heat Pump	11.8%	6,956	824	95,672
Space Heating	Geothermal Heat Pump	0.5%	6,387	34	3,895
Space Heating	Secondary Heating	49.7%	1,482	736	85,472
Water Heating	Water Heater <= 55 Gal	44.7%	2,884	1,290	149,797
Water Heating	Water Heater > 55 Gal	2.1%	3,010	64	7,379
Interior Lighting	General Service Screw-in	100.0%	627	627	72,828
Interior Lighting	Linear Lighting	100.0%	99	99	11,477
Interior Lighting	Exempted Screw-In	100.0%	189	189	21,997
Exterior Lighting	Screw-in	100.0%	227	227	26,365
Appliances	Clothes Washer	83.0%	103	86	9,963
Appliances	Clothes Dryer	80.2%	748	600	69,687
Appliances	Dishwasher	74.4%	85	64	7,390
Appliances	Refrigerator	100.0%	520	520	60,341
Appliances	Freezer	39.9%	461	184	21,390
Appliances	Second Refrigerator	24.8%	809	200	23,269
Appliances	Stove/Oven	84.0%	165	138	16,045
Appliances	Microwave	91.2%	114	104	12,028
Electronics	Personal Computers	66.0%	146	96	11,204
Electronics	Monitor	119.8%	58	69	8,011
Electronics	Laptops	45.0%	38	17	1,986
Electronics	TVs	187.8%	100	188	21,870
Electronics	Printer/Fax/Copier	55.1%	40	22	2,577
Electronics	Set-top Boxes/DVRs	101.2%	95	96	11,119
Electronics	Devices and Gadgets	100.0%	243	243	28,225
Miscellaneous	Electric Vehicles	0.5%	3,153	16	1,845
Miscellaneous	Pool Pump	1.1%	1,313	14	1,613
Miscellaneous	Pool Heater	0.2%	3,517	7	823
Miscellaneous	Hot Tub / Spa	4.7%	1,881	88	10,169
Miscellaneous	Furnace Fan	41.4%	290	120	13,931
Miscellaneous	Well pump	1.7%	555	10	1,104
Miscellaneous	Miscellaneous	100.0%	691	691	80,180
Generation	Solar PV	0.3%	-7,809	-23	-2,626
<b>Total</b>				<b>10,643</b>	<b>1,235,752</b>

## Commercial Sector

The total electric energy consumed by commercial customers in Avista's service area in 2017 was 2,166 GWh (WA) and 1,007 GWh (ID). Avista billing data, CBSA and secondary data were used to allocate this energy usage to building type segments and to develop estimates of energy intensity (annual kWh/square foot). Using the electricity use and intensity estimates, we infer floor space which is the unit of analysis in LoadMAP for the commercial sector. The values are shown in Table 3-7 (WA) and Table 3-8 (ID). The average building intensities by segment are based on regional information from the CBSA, therefore the intensity is the same both states. However, due to the different mix of building types, overall end use mix is different as shown in Figure 3-9 and Figure 3-10.

Table 3-7 Commercial Sector Control Totals (2019), Washington

Segment	Electricity Sales (GWh)	% of Total Usage	Intensity
Small Office	192	9%	15.6
Large Office	507	23%	17.3
Restaurant	113	5%	40.9
Retail	278	13%	12.2
Grocery	193	9%	43.4
College	114	5%	16.2
School	146	7%	9.1
Health	119	5%	23.3
Lodging	86	4%	12.2
Warehouse	95	4%	4.7
Miscellaneous	324	15%	10.3
<b>Total</b>	<b>2,166</b>	<b>100%</b>	<b>13.7</b>

Table 3-8 Commercial Sector Control Totals (2019), Idaho

Segment	Electricity Sales (GWh)	% of Total Usage	Intensity
Small Office	186	9%	15.6
Large Office	167	8%	17.3
Restaurant	33	2%	40.9
Retail	143	7%	12.2
Grocery	10	0%	43.5
College	72	3%	16.2
School	5	0%	9.1
Health	59	3%	23.3
Lodging	76	4%	12.3
Warehouse	55	3%	4.7
Miscellaneous	201	9%	10.3
<b>Total</b>	<b>1,007</b>	<b>100%</b>	<b>12.7</b>

Figure 3-7 (WA) and Figure 3-8 (ID) show the distribution of annual electricity consumption and summer peak demand by end use across all commercial buildings. Electric usage is dominated by lighting and ventilation, which comprise almost 44% of annual electricity usage. Lighting and ventilation also make up the largest portions of winter peak, however electric space heating represents a greater part of the peak than it does annual energy.

Figure 3-9 (WA) and Figure 3-10 (ID) presents the electricity usage in GWh by end use and segment. In Washington, Large offices, retail, and miscellaneous buildings use the most electricity in the service territory. For Idaho, Large and Small Offices are more balanced in terms of total consumption. HVAC and lighting are the major end uses across most segments, aside from Large Offices and grocery, where office equipment and refrigeration equipment, respectively, are highly concentrated.

Figure 3-7 Commercial Electricity Use and Winter Peak Demand by End Use (2019), Washington

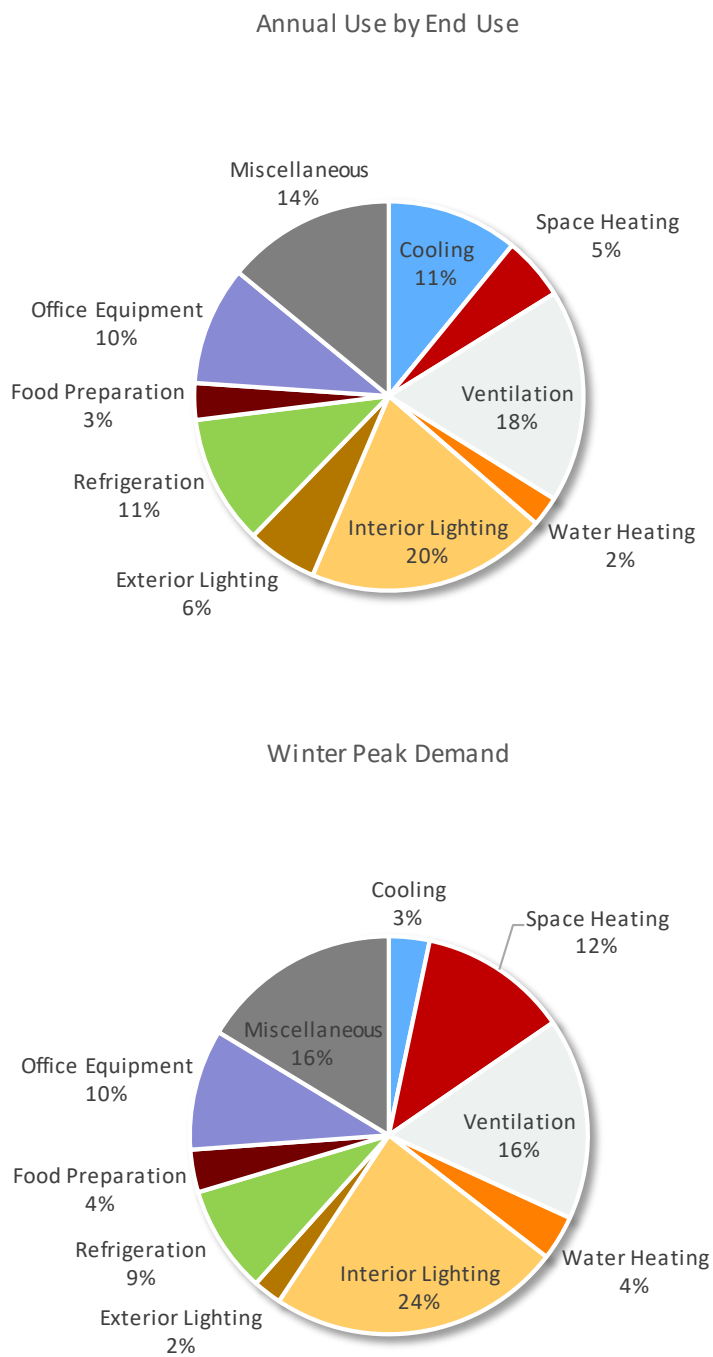

Figure 3-8 Commercial Electricity Use and Winter Peak Demand by End Use (2019), Idaho

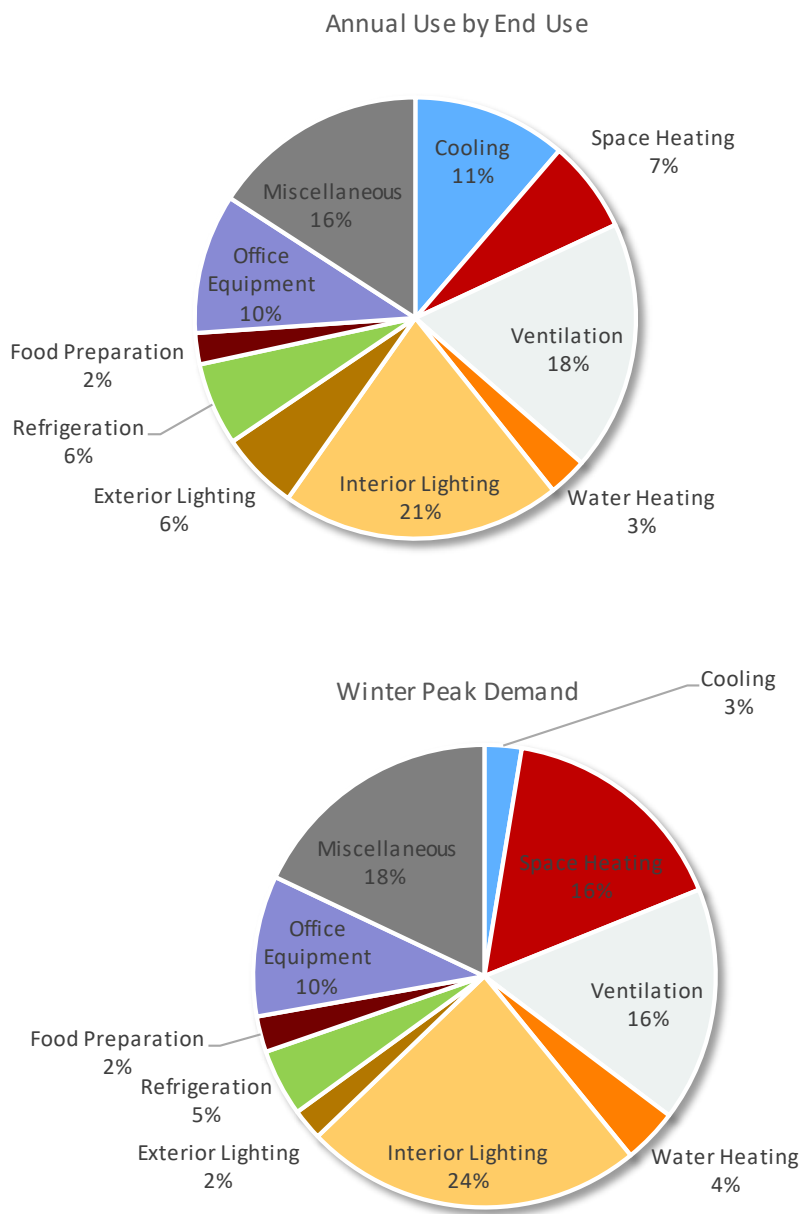

Figure 3-9 Commercial Electricity Usage by End Use Segment (GWh, 2019), Washington

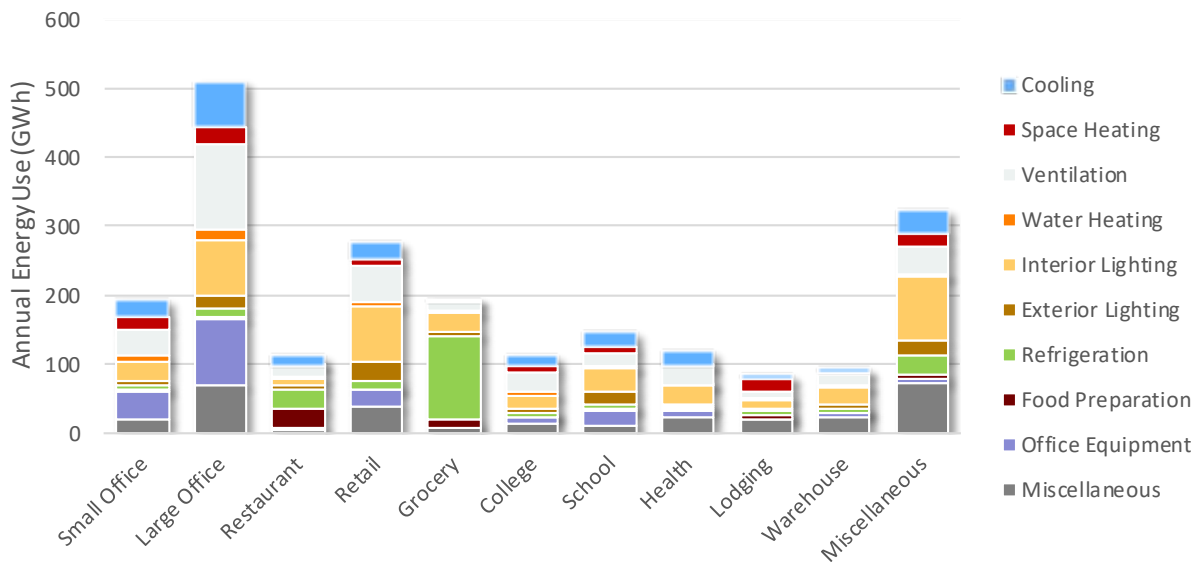

Figure 3-10 Commercial Electricity Usage by End Use Segment (GWh, 2019), Idaho

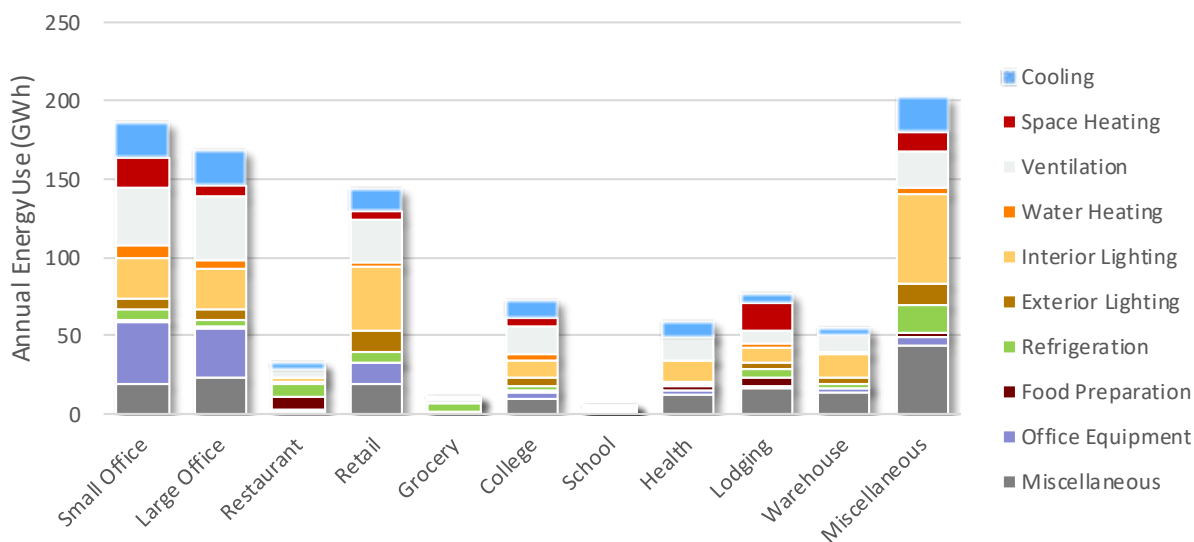

Table 3-9 (WA) and Table 3-10 (ID) show the average market profile for electricity of the commercial sector as a whole, representing a composite of all segments and buildings. Market profiles for each segment are presented in the appendix to this volume.

Table 3-9 Average Electric Market Profile for the Commercial Sector, 2019, Washington

End Use	Technology	Saturation	EUI	Intensity	Usage
			(kWh/Sq.Ft.)	(kWh/Sq.Ft.)	(GWh)
Cooling	Air-Cooled Chiller	8.4%	2.25	0.19	31.0
Cooling	Water-Cooled Chiller	4.7%	3.32	0.15	25.5
Cooling	RTU	43.1%	1.88	0.81	133.2
Cooling	PTAC	4.2%	1.51	0.06	10.4
Cooling	PTHP	1.6%	1.57	0.03	4.2
Cooling	Evaporative AC	0.6%	0.79	0.00	0.7
Cooling	Air-Source Heat Pump	6.8%	2.00	0.14	22.5
Cooling	Geothermal Heat Pump	3.1%	1.72	0.05	8.8
Heating	Electric Furnace	2.6%	2.58	0.07	11.1
Heating	Electric Room Heat	14.1%	2.67	0.38	61.9
Heating	PTHP	1.6%	2.45	0.04	6.6
Heating	Air-Source Heat Pump	6.8%	2.12	0.14	23.8
Heating	Geothermal Heat Pump	3.1%	2.06	0.06	10.6
Ventilation	Ventilation	100.0%	2.33	2.33	383.2
Water Heating	Water Heater	31.5%	1.04	0.33	53.8
Interior Lighting	General Service Lighting	100.0%	0.32	0.32	52.8
Interior Lighting	Exempted Lighting	100.0%	0.08	0.08	13.1
Interior Lighting	High-Bay Lighting	100.0%	0.33	0.33	54.9
Interior Lighting	Linear Lighting	100.0%	1.91	1.91	313.4
Exterior Lighting	General Service Lighting	100.0%	0.18	0.18	28.9
Exterior Lighting	Area Lighting	100.0%	0.39	0.39	63.4
Exterior Lighting	Linear Lighting	100.0%	0.21	0.21	34.5
Refrigeration	Walk-in Refrigerator/Freezer	7.8%	1.16	0.09	14.8
Refrigeration	Reach-in Refrigerator/Freezer	15.5%	1.25	0.19	31.9
Refrigeration	Glass Door Display	33.0%	1.05	0.35	56.8
Refrigeration	Open Display Case	33.0%	1.39	0.46	75.6
Refrigeration	Icemaker	32.7%	0.73	0.24	39.1
Refrigeration	Vending Machine	32.7%	0.28	0.09	15.2
Food Preparation	Oven	22.9%	0.18	0.04	6.6
Food Preparation	Fryer	28.3%	0.54	0.15	25.0
Food Preparation	Dishwasher	19.8%	0.35	0.07	11.6
Food Preparation	Hot Food Container	20.9%	0.13	0.03	4.3
Food Preparation	Steamer	18.2%	0.34	0.06	10.1
Food Preparation	Griddle	17.7%	0.28	0.05	8.3
Office Equipment	Desktop Computer	100.0%	0.39	0.39	64.5
Office Equipment	Laptop	99.0%	0.12	0.12	20.0
Office Equipment	Server	91.0%	0.69	0.63	103.0
Office Equipment	Monitor	100.0%	0.07	0.07	11.4
Office Equipment	Printer/Copier/Fax	100.0%	0.03	0.03	5.1
Office Equipment	POS Terminal	57.1%	0.11	0.06	10.0
Miscellaneous	Non-HVAC Motors	48.3%	0.54	0.26	42.5
Miscellaneous	Pool Pump	8.8%	0.13	0.01	1.9
Miscellaneous	Pool Heater	3.1%	0.17	0.01	0.8
Miscellaneous	Clothes Washer	10.2%	0.05	0.01	0.9
Miscellaneous	Clothes Dryer	6.6%	0.19	0.01	2.1
Miscellaneous	Other Miscellaneous	100.0%	1.56	1.56	256.1
Generation	Solar PV	0.0%	0.00	0.00	0.0
<b>Total</b>				<b>13.17</b>	<b>2,166.0</b>

| 46

Table 3-10 Average Electric Market Profile for the Commercial Sector, 2019, Idaho

End Use	Technology	Saturation	EUI	Intensity	Usage
			(kWh/Sq.Ft.)	(kWh/Sq.Ft.)	(GWh)
Cooling	Air-Cooled Chiller	0.8%	1.57	0.01	0.2
Cooling	Water-Cooled Chiller	0.5%	1.71	0.01	0.1
Cooling	RTU	58.5%	1.59	0.93	11.3
Cooling	PTAC	2.6%	1.67	0.04	0.5
Cooling	PTHP	0.5%	1.58	0.01	0.1
Cooling	Evaporative AC	3.0%	0.63	0.02	0.2
Cooling	Air-Source Heat Pump	3.1%	1.58	0.05	0.6
Cooling	Geothermal Heat Pump	0.0%	1.24	0.00	0.0
Heating	Electric Furnace	1.0%	3.09	0.03	0.4
Heating	Electric Room Heat	11.5%	2.95	0.34	4.1
Heating	PTHP	0.5%	2.09	0.01	0.1
Heating	Air-Source Heat Pump	3.1%	2.32	0.07	0.9
Heating	Geothermal Heat Pump	0.0%	2.02	0.00	0.0
Ventilation	Ventilation	100.0%	2.23	2.23	27.1
Water Heating	Water Heater	38.2%	0.73	0.28	3.4
Interior Lighting	General Service Lighting	100.0%	0.19	0.19	2.3
Interior Lighting	Exempted Lighting	100.0%	0.05	0.05	0.6
Interior Lighting	High-Bay Lighting	100.0%	0.71	0.71	8.6
Interior Lighting	Linear Lighting	100.0%	2.36	2.36	28.8
Exterior Lighting	General Service Lighting	100.0%	0.33	0.33	4.0
Exterior Lighting	Area Lighting	100.0%	0.67	0.67	8.1
Exterior Lighting	Linear Lighting	100.0%	0.20	0.20	2.5
Refrigeration	Walk-in Refrigerator/Freezer	0.0%	1.27	0.00	0.0
Refrigeration	Reach-in Refrigerator/Freezer	5.4%	1.52	0.08	1.0
Refrigeration	Glass Door Display	5.4%	1.56	0.08	1.0
Refrigeration	Open Display Case	5.4%	5.03	0.27	3.3
Refrigeration	Icemaker	5.1%	1.28	0.07	0.8
Refrigeration	Vending Machine	5.1%	0.61	0.03	0.4
Food Preparation	Oven	3.6%	0.12	0.00	0.1
Food Preparation	Fryer	3.6%	0.17	0.01	0.1
Food Preparation	Dishwasher	3.6%	0.11	0.00	0.0
Food Preparation	Hot Food Container	3.6%	0.03	0.00	0.0
Food Preparation	Steamer	3.6%	0.18	0.01	0.1
Food Preparation	Griddle	3.6%	0.17	0.01	0.1
Office Equipment	Desktop Computer	100.0%	0.16	0.16	2.0
Office Equipment	Laptop	100.0%	0.05	0.05	0.6
Office Equipment	Server	100.0%	0.46	0.46	5.6
Office Equipment	Monitor	100.0%	0.03	0.03	0.4
Office Equipment	Printer/Copier/Fax	100.0%	0.05	0.05	0.6
Office Equipment	POS Terminal	100.0%	0.32	0.32	3.9
Miscellaneous	Non-HVAC Motors	22.0%	1.17	0.26	3.1
Miscellaneous	Pool Pump	0.0%	0.77	0.00	0.0
Miscellaneous	Pool Heater	0.0%	1.00	0.00	0.0
Miscellaneous	Clothes Washer	0.0%	0.24	0.00	0.0
Miscellaneous	Clothes Dryer	0.0%	0.79	0.00	0.0
Miscellaneous	Other Miscellaneous	100.0%	1.32	1.32	16.1
Generation	Solar PV	0.0%	0.00	0.00	0.0
<b>Total</b>				<b>11.75</b>	<b>143.0</b>

| 47



## Industrial Sector

The total electricity used in 2019 by Avista’s industrial customers was 846 GWh; 500 GWh (WA) and 346 GWh (ID). Avista billing data and load forecast, NEEA’s IFSA, and secondary sources were used to develop estimates of energy intensity (annual kWh/employee). Using the electricity use and intensity estimates, we infer the number of employees which is the unit of analysis in LoadMAP for the industrial sector. These are shown in Table 3-11.

Table 3-11 Industrial Sector Control Totals (2019)

State	Electricity Sales (GWh)	Intensity (Annual kWh/employee)	Winter Peak (MW)
Washington	500	42,527	164
Idaho	346	29,394	68

Figure 3-12 shows the distribution of annual electricity consumption and summer peak demand by end use for all industrial customers. Motors are the largest overall end use for the industrial sector, accounting for 47% of energy use. Note that this end use includes a wide range of industrial equipment, such as air compressors and refrigeration compressors, pumps, conveyor motors, and fans. The process end use accounts for 25% of annual energy use, which includes heating, cooling, refrigeration, and electro-chemical processes. Lighting is the next highest, followed by cooling, miscellaneous, heating and ventilation.

Table 3-12 and Table 3-13 show the composite market profile for the industrial sector.

Figure 3-11 Industrial Electricity Use and Winter Peak Demand by End Use (2019), All Industries, WA

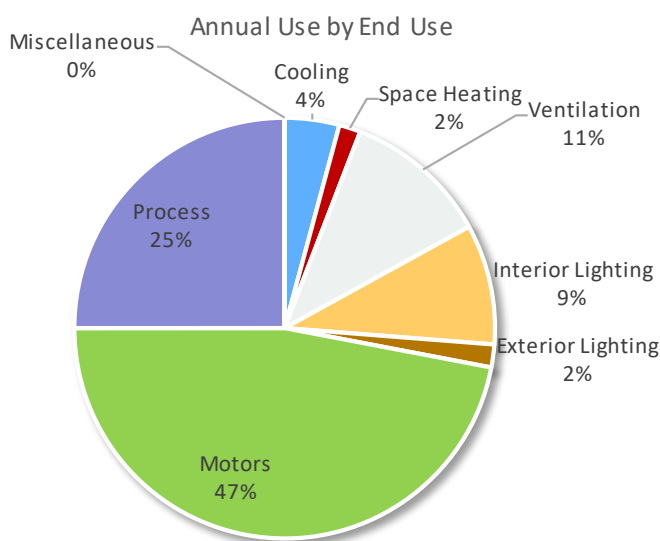

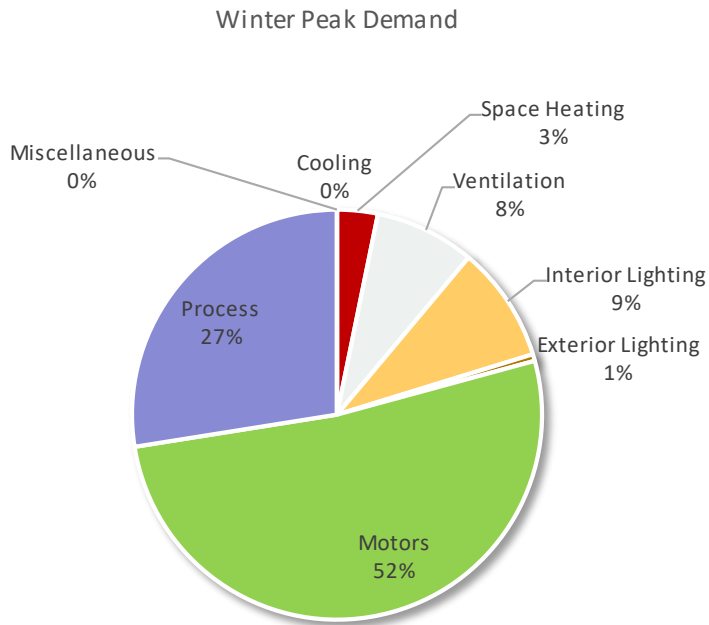
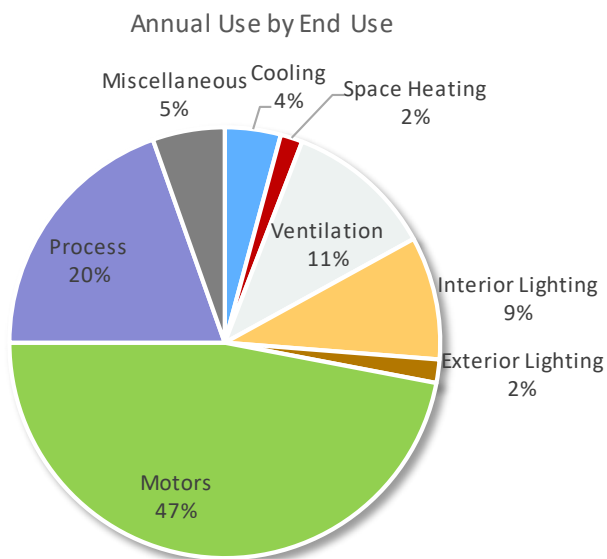

Figure 3-12 Industrial Electricity Use and Winter Peak Demand by End Use (2019), All Industries, ID



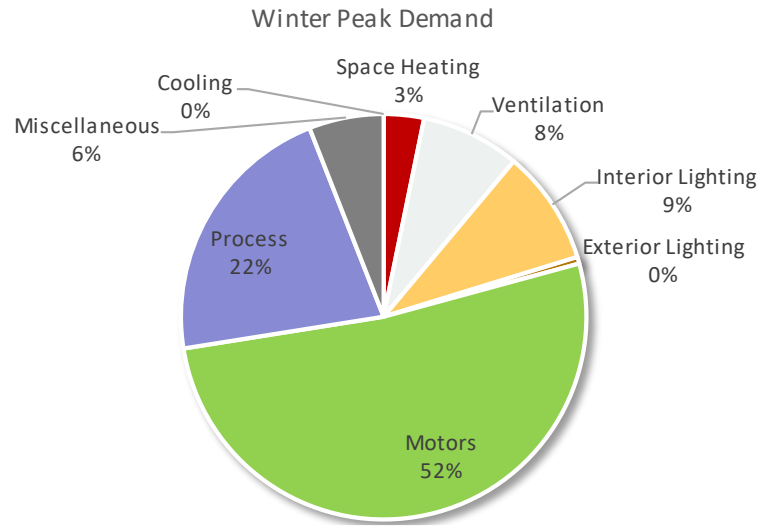

Table 3-12 Average Electric Market Profile for the Industrial Sector, 2019, Washington

End Use	Technology	Saturation	EUI (kWh)	Intensity (kWh/Employee)	Usage (GWh)
Cooling	Air-Cooled Chiller	2.5%	10,819.85	270.50	3.2
Cooling	Water-Cooled Chiller	2.5%	12,534.09	313.35	3.7
Cooling	RTU	10.2%	10,083.74	1,030.52	12.1
Cooling	Air-Source Heat Pump	1.7%	10,077.53	170.41	2.0
Cooling	Geothermal Heat Pump	0.0%	1.00	0.00	0.0
Heating	Electric Furnace	0.5%	16,090.76	76.54	0.9
Heating	Electric Room Heat	2.6%	15,324.53	394.31	4.6
Heating	Air-Source Heat Pump	1.7%	13,686.41	231.44	2.7
Heating	Geothermal Heat Pump	0.0%	1.00	0.00	0.0
Ventilation	Ventilation	100.0%	4,742.42	4,742.42	55.8
Interior Lighting	General Service Lighting	100.0%	106.36	106.36	1.3
Interior Lighting	High-Bay Lighting	100.0%	1,912.71	1,912.71	22.5
Interior Lighting	Linear Lighting	100.0%	1,912.71	1,912.71	22.5
Exterior Lighting	General Service Lighting	100.0%	134.90	134.90	1.6
Exterior Lighting	Area Lighting	100.0%	254.16	254.16	3.0
Exterior Lighting	Linear Lighting	100.0%	357.08	357.08	4.2
Motors	Pumps	100.0%	4,252.64	4,252.64	50.0
Motors	Fans & Blowers	100.0%	2,976.85	2,976.85	35.0
Motors	Compressed Air	100.0%	2,976.85	2,976.85	35.0
Motors	Material Handling	100.0%	8,505.29	8,505.29	100.0
Motors	Other Motors	100.0%	1,275.79	1,275.79	15.0
Process	Process Heating	100.0%	4,677.91	4,677.91	55.0
Process	Process Cooling	100.0%	1,275.79	1,275.79	15.0
Process	Process Refrigeration	100.0%	1,275.79	1,275.79	15.0
Process	Process Electrochemical	100.0%	2,625.61	2,625.61	30.9
Process	Process Other	100.0%	776.51	776.51	9.1
Miscellaneous	Miscellaneous	0.0%	1.00	0.00	0.0
<b>Total</b>				<b>42,526.45</b>	<b>500.1</b>

Table 3-13 Average Electric Market Profile for the Industrial Sector, 2019, Idaho

End Use	Technology	Saturation	EUI (kWh)	Intensity (kWh/Employee)	Usage (GWh)
Cooling	Air-Cooled Chiller	2.5%	15,505.86	387.65	2.2
Cooling	Water-Cooled Chiller	2.5%	17,962.52	449.06	2.5
Cooling	RTU	10.2%	14,450.94	1,476.83	8.4
Cooling	Air-Source Heat Pump	1.7%	14,442.05	244.21	1.4
Cooling	Geothermal Heat Pump	0.0%	1.00	0.00	0.0
Heating	Electric Furnace	0.5%	23,059.55	109.70	0.6
Heating	Electric Room Heat	2.6%	21,961.48	565.09	3.2
Heating	Air-Source Heat Pump	1.7%	19,613.90	331.67	1.9
Heating	Geothermal Heat Pump	0.0%	1.00	0.00	0.0
Ventilation	Ventilation	100.0%	6,796.33	6,796.33	38.5
Interior Lighting	General Service Lighting	100.0%	152.42	152.42	0.9
Interior Lighting	High-Bay Lighting	100.0%	2,741.09	2,741.09	15.5
Interior Lighting	Linear Lighting	100.0%	2,741.09	2,741.09	15.5
Exterior Lighting	General Service Lighting	100.0%	193.33	193.33	1.1
Exterior Lighting	Area Lighting	100.0%	364.23	364.23	2.1
Exterior Lighting	Linear Lighting	100.0%	511.72	511.72	2.9
Motors	Pumps	100.0%	6,094.44	6,094.44	34.6
Motors	Fans & Blowers	100.0%	4,266.10	4,266.10	24.2
Motors	Compressed Air	100.0%	4,266.10	4,266.10	24.2
Motors	Material Handling	100.0%	12,188.87	12,188.87	69.1
Motors	Other Motors	100.0%	1,828.33	1,828.33	10.4
Process	Process Heating	100.0%	6,703.88	6,703.88	38.0
Process	Process Cooling	100.0%	1,828.33	1,828.33	10.4
Process	Process Refrigeration	100.0%	1,828.33	1,828.33	10.4
Process	Process Electrochemical	100.0%	426.33	426.33	2.4
Process	Process Other	100.0%	1,148.34	1,148.34	6.5
Miscellaneous	Miscellaneous	100.0%	3,300.88	3,300.88	18.7
<b>Total</b>				<b>60,944.36</b>	<b>345.6</b>

## 4

## BASELINE PROJECTION

Prior to developing estimates of energy-efficiency potential, we developed a baseline end-use projection to quantify what the consumption is likely to be in the future and in absence of any future conservation programs. The savings from past programs are embedded in the forecast, but the baseline projection assumes that those past programs cease to exist in the future. Possible savings from future programs are captured by the potential estimates.

The baseline projection incorporates assumptions about:

- Customer population and economic growth
- Appliance/equipment standards and building codes already mandated (see Chapter 2)
- Forecasts of future electricity prices and other drivers of consumption
- Trends in fuel shares and appliance saturations and assumptions about miscellaneous electricity growth

Although it aligns closely with it, the baseline projection is not Avista's official load forecast. Rather it was developed to serve as the metric against which EE potentials are measured. This chapter presents the baseline projections we developed for this study. Below, we present the baseline projections for each sector and state, which include projections of annual use in GWh and summer peak demand in MW. We also present a summary across all sectors.

Please note that the base-year for the study is 2019. Annual energy use and summer peak demand values for 2019 reflect weather-normalized values. In future years, energy use and peak demand reflect normal weather, as defined by Avista.

### Residential Sector

#### Annual Use

Table 4-1 (WA) and Table 4-2 (ID) present the baseline projection for electricity at the end-use level for the residential sector as a whole. Overall in Washington, residential use increases from 2,539 GWh in 2019 to 2,976 GWh in 2041, an increase of 17%. Residential use in Idaho increases from 1,236 GWh in 2019 to 1,513 GWh in 2041, an increase of 22%. This reflects a substantial customer growth forecast in both states. Figure 4-1 (WA) and Figure 4-3 (ID) display the graphical representation of the baseline projection.

Figure 4-2 (WA) and Figure 4-4 (ID) present the baseline projection of annual electricity use per household. Most noticeable is that lighting use decreases throughout the time period – this is the combined effect of the RTF market baseline assumption in both states, and is further enhanced in Washington by state lighting standards in effect from 2020 forward.

Table 4-1 Residential Baseline Sales Projection by End Use (GWh), Washington

End Use	2019	2022	2023	2026	2031	2041	% Change ('19-'41)
Cooling	187	202	205	218	247	350	87%
Space Heating	956	924	926	932	940	958	0%
Water Heating	420	408	405	398	387	369	-12%
Interior Lighting	177	158	149	118	93	82	-54%
Exterior Lighting	34	28	26	20	16	13	-61%
Appliances	414	425	429	442	463	498	20%
Electronics	170	185	190	206	234	294	73%
Miscellaneous	187	202	207	226	269	461	146%
Generation	-5	-7	-8	-11	-18	-48	825%
<b>Total</b>	<b>2,539</b>	<b>2,525</b>	<b>2,529</b>	<b>2,548</b>	<b>2,631</b>	<b>2,976</b>	<b>17%</b>

Figure 4-1 Residential Baseline Projection by End Use (GWh), Washington

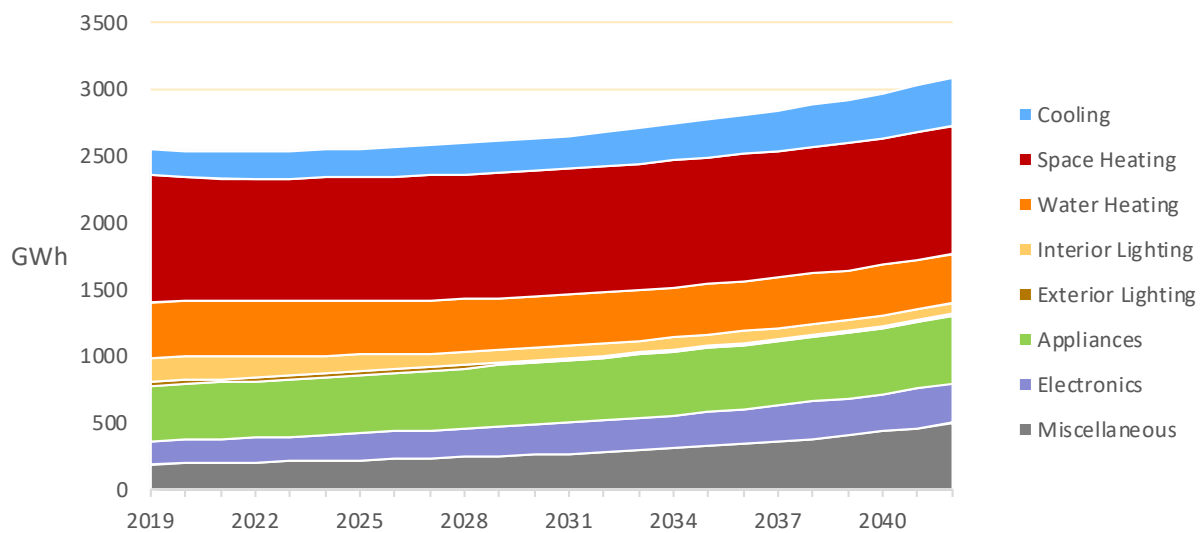

Figure 4-2 Residential Baseline Projection by End Use – Annual Use per Household, Washington

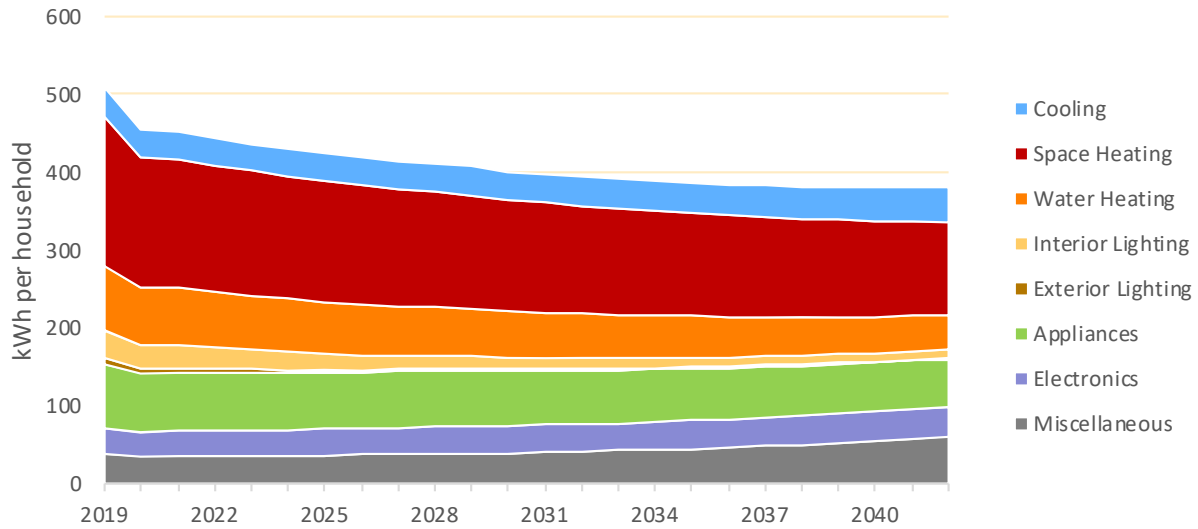

Table 4-2 Residential Baseline Sales Projection by End Use (GWh), Idaho

End Use	2019	2022	2023	2026	2031	2041	% Change ('19-'41)
Cooling	77	88	91	102	125	185	142%
Space Heating	457	447	449	455	460	469	2%
Water Heating	157	155	155	153	150	143	-9%
Interior Lighting	106	101	95	73	55	48	-55%
Exterior Lighting	26	20	18	12	9	7	-75%
Appliances	220	229	232	241	253	271	23%
Electronics	85	92	94	101	110	131	54%
Miscellaneous	110	122	126	141	171	285	160%
Generation	-3	-4	-4	-6	-9	-25	848%
<b>Total</b>	<b>1,236</b>	<b>1,250</b>	<b>1,256</b>	<b>1,272</b>	<b>1,322</b>	<b>1,513</b>	<b>22%</b>



Figure 4-3 Residential Baseline Projection by End Use (GWh), Idaho

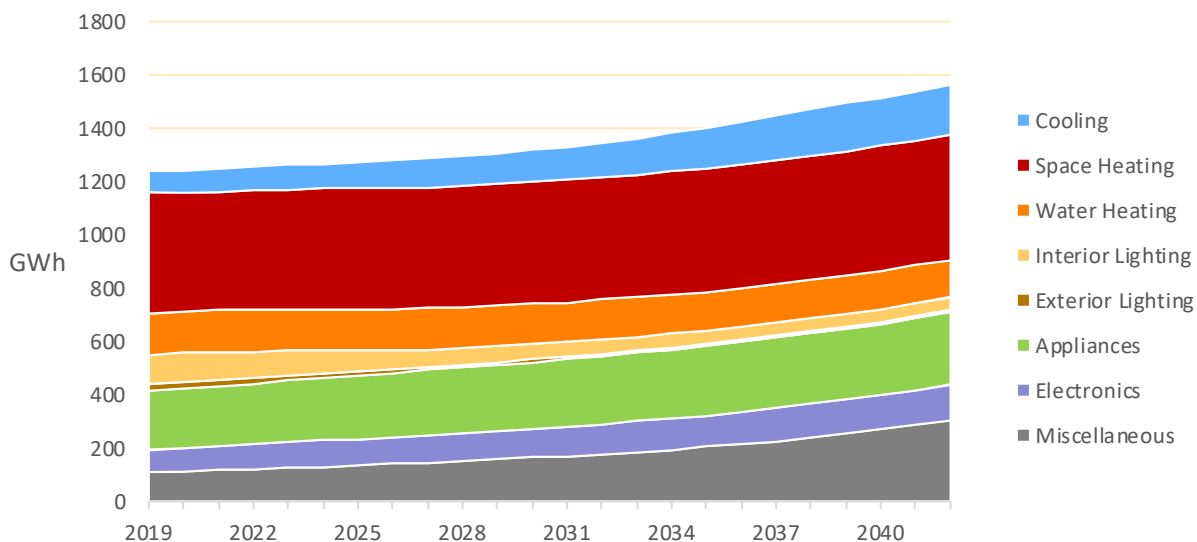
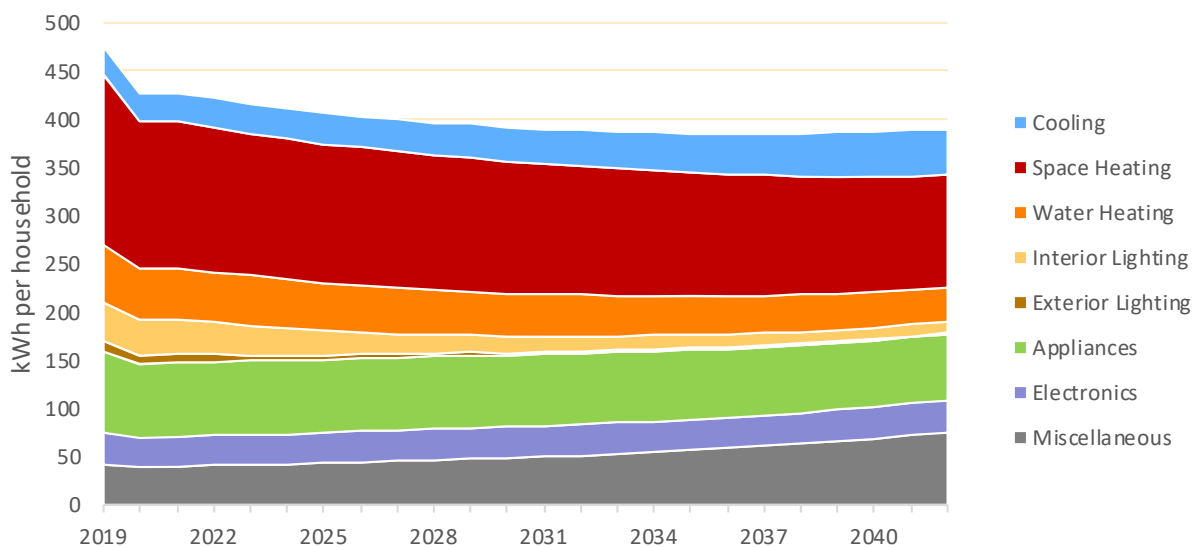

Figure 4-4 Residential Baseline Sales Projection by End Use – Annual Use per Household, Idaho



## Commercial Sector Baseline Projections

### Annual Use

In Washington, annual electricity use in the commercial sector grows during the overall forecast horizon, starting at 2,166 GWh in 2019, and increasing to 2,811 in 2041, an increase of 30%. In Idaho, annual

electricity use grows from 1,007 GWh in 2017 to 1,112 GWh in 2041, an increase of 10%. The tables and graphs below present the baseline projection at the end-use level for the commercial sector as a whole.

Table 4-3 Commercial Baseline Sales Projection by End Use (GWh), Washington

End Use	2019	2022	2023	2026	2031	2041	% Change ('19-'41)
Cooling	236	250	250	251	254	265	12%
Space Heating	114	112	112	115	120	130	14%
Ventilation	383	379	379	374	365	359	-6%
Water Heating	54	55	55	56	58	63	18%
Interior Lighting	434	417	411	395	388	404	-7%
Exterior Lighting	127	118	115	108	105	107	-16%
Refrigeration	233	243	247	260	283	346	48%
Food Preparation	66	69	70	72	81	106	60%
Office Equipment	214	217	217	218	239	299	39%
Miscellaneous	304	341	355	402	492	733	141%
<b>Total</b>	<b>2,166</b>	<b>2,201</b>	<b>2,211</b>	<b>2,252</b>	<b>2,385</b>	<b>2,811</b>	<b>30%</b>

Table 4-4 Commercial Baseline Sales Projection by End Use (GWh), Idaho

End Use	2019	2022	2023	2026	2031	2041	% Change ('19-'41)
Cooling	114	122	122	124	126	134	18%
Space Heating	68	68	68	70	74	82	20%
Ventilation	185	185	185	184	181	182	-2%
Water Heating	29	30	30	31	32	36	24%
Interior Lighting	207	204	201	191	188	198	-4%
Exterior Lighting	58	56	55	51	49	51	-13%
Refrigeration	61	62	63	64	67	74	20%
Food Preparation	23	24	24	25	26	29	25%
Office Equipment	103	106	108	111	117	127	23%
Miscellaneous	160	165	167	172	181	201	26%
<b>Total</b>	<b>1,007</b>	<b>1,022</b>	<b>1,023</b>	<b>1,022</b>	<b>1,041</b>	<b>1,112</b>	<b>10%</b>

Figure 4-5 Commercial Baseline Projection by End Use, Washington

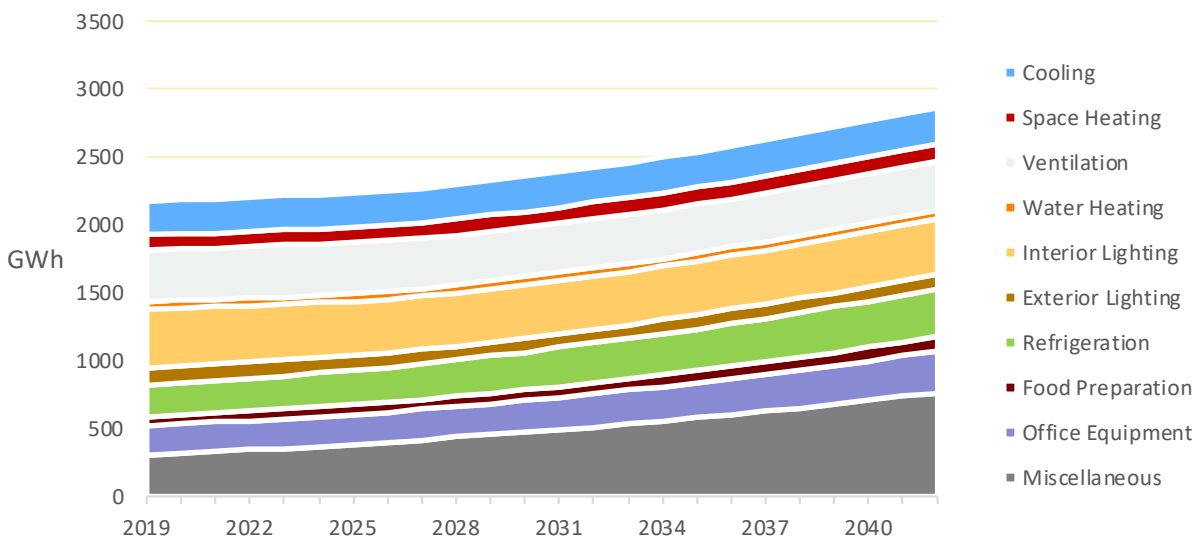
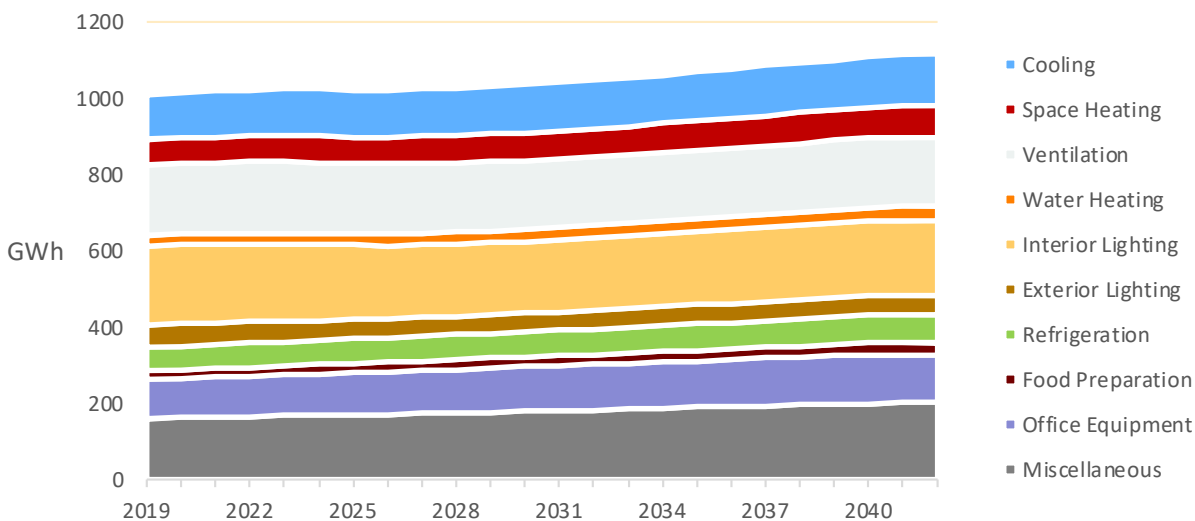

Figure 4-6 Commercial Baseline Projection by End Use, Idaho



## Industrial Sector Baseline Projections

### Annual Use

Annual industrial use declined by 8% through the forecast horizon, consistent with trends from Avista's industrial load forecast. The tables and graphs below present the projection at the end-use level. Overall in Washington, industrial annual electricity use decreases from 500 GWh in 2017 to 455 GWh in 2041. In Idaho, annual electricity use drops from 346 GWh in 2019 to 325 GWh in 2041.

Table 4-5 Industrial Baseline Projection by End Use (GWh), Washington

End Use	2019	2022	2023	2026	2031	2041	% Change ('19-'41)
Cooling	21	21	21	20	20	19	-11%
Space Heating	8	8	8	8	8	8	-9%
Ventilation	56	51	51	50	47	42	-24%
Interior Lighting	46	42	42	41	40	38	-17%
Exterior Lighting	9	8	7	7	7	6	-28%
Process	125	119	119	119	119	119	-5%
Motors	235	223	224	224	224	223	-5%
Miscellaneous	0	0	0	0	0	0	76%
<b>Total</b>	<b>500</b>	<b>471</b>	<b>472</b>	<b>468</b>	<b>463</b>	<b>455</b>	<b>-9%</b>

Table 4-6 Industrial Baseline Projection by End Use (GWh), Idaho

End Use	2019	2022	2023	2026	2031	2041	% Change ('19-'41)
Cooling	15	16	16	16	15	13	-9%
Space Heating	6	6	6	6	6	5	-7%
Ventilation	39	41	40	38	35	30	-23%
Interior Lighting	32	33	33	31	30	27	-15%
Exterior Lighting	6	6	6	5	5	4	-27%
Process	68	74	73	72	70	66	-3%
Motors	162	177	176	173	168	158	-3%
Miscellaneous	19	21	21	21	22	22	18%
<b>Total</b>	<b>346</b>	<b>374</b>	<b>371</b>	<b>362</b>	<b>349</b>	<b>325</b>	<b>-6%</b>

Figure 4-7 Industrial Baseline Projection by End Use (GWh), Washington

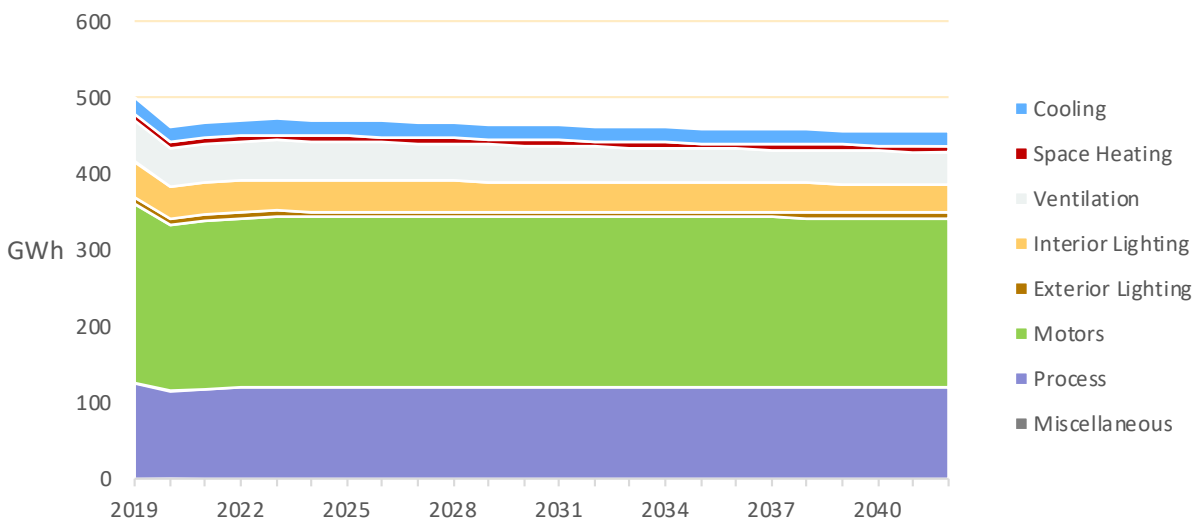
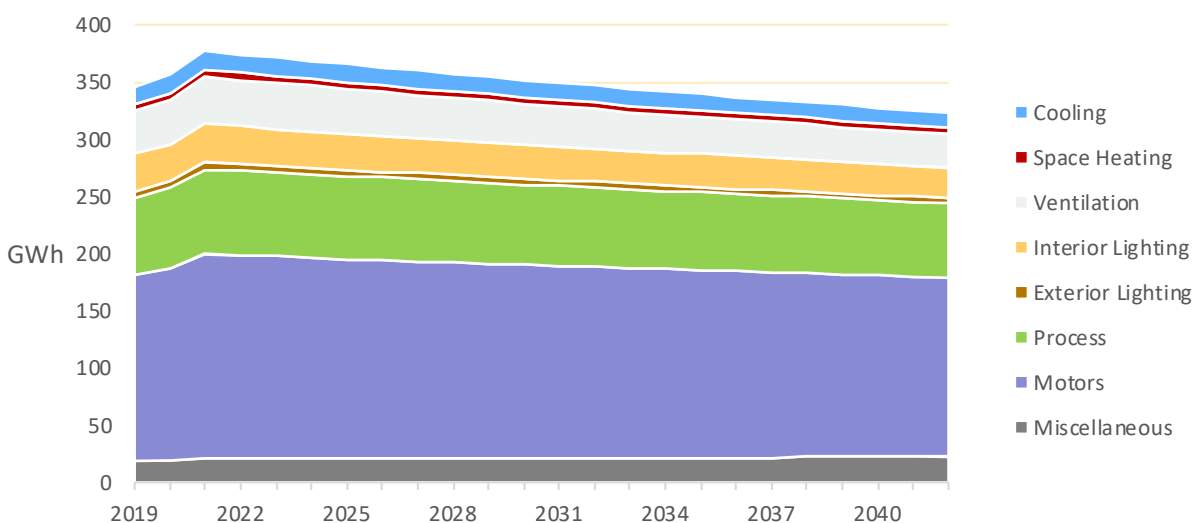

Figure 4-8 Industrial Baseline Projection by End Use (GWh), Idaho



## Summary of Baseline Projections across Sectors and States

### Annual Use

Table 4-7 and Figure 4-9 provide a summary of the baseline projection for annual use by sector for the entire Avista service territory. Overall, the projection shows steady growth in electricity use, driven primarily by customer growth forecasts.

Table 4-7 Baseline Projection Summary (GWh), WA and ID Combined

End Use	2019	2022	2023	2026	2031	2041	% Change ('19-'41)
Residential	3,775	3,774	3,785	3,820	3,953	4,489	19%
Commercial	3,173	3,223	3,234	3,273	3,427	3,924	24%
Industrial	846	845	843	831	812	780	-8%
<b>Total</b>	<b>7,794</b>	<b>7,842</b>	<b>7,863</b>	<b>7,925</b>	<b>8,192</b>	<b>9,193</b>	<b>18%</b>

Figure 4-9 Baseline Projection Summary (GWh), WA and ID Combined

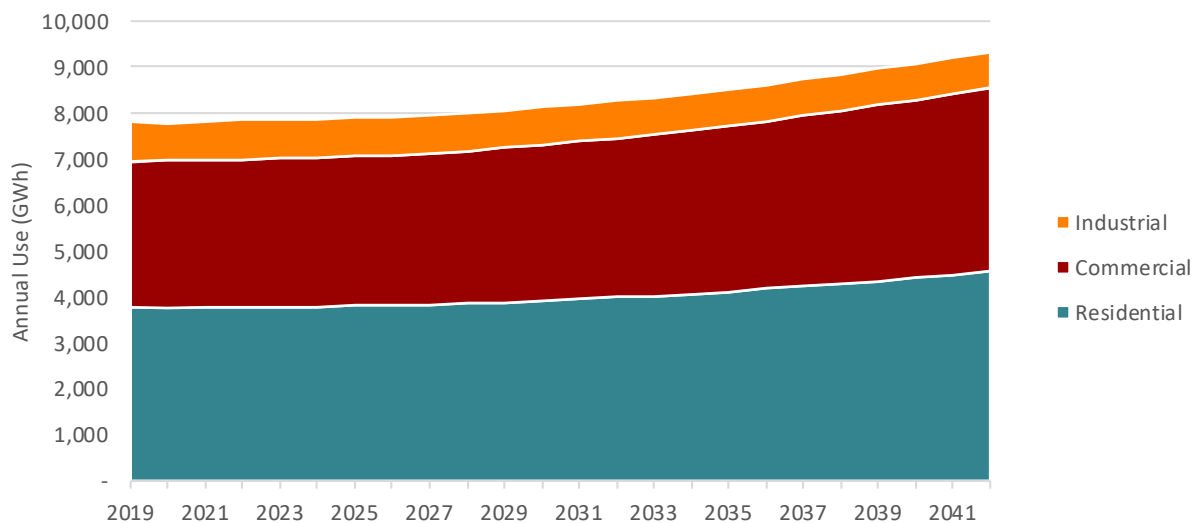

# 5

## CONSERVATION POTENTIAL

This section presents the conservation potential for Avista. This includes every measure that is considered in the measure list, regardless of delivery mechanism (program implementation, NEEA initiatives, or momentum savings).

We present the annual energy savings in GWh and aMW, as well as the winter peak demand savings in MW, for selected years. Year-by-year savings for annual energy and peak demand are available in the LoadMAP model, which was provided to Avista at the conclusion of the study.

This section begins a summary of annual energy savings across all three sectors. Then we provide details for each sector. Please note that all savings are provided at the customer meter.

### Overall Summary of Energy Efficiency Potential

#### Summary of Annual Energy Savings

Table 5-1 (WA) and Table 5-2 (ID) summarize the EE savings in terms of annual energy use for all measures for two levels of potential relative to the baseline projection. Figure 5-1(WA) and Figure 5-2 (ID) displays the two levels of potential by year. Figure 5-3 (WA) and Figure 5-4 (ID) display the EE projections.

- Technical Potential** reflects the adoption of all conservation measures regardless of cost-effectiveness. For Washington, first-year savings are 101 GWh, or 2.0% of the baseline projection. Cumulative savings in 2041 are 1,822 GWh, or 29.2% of the baseline. For Idaho, first-year savings are 58 GWh, or 2.2% of the baseline projection. Cumulative savings in 2041 are 948 GWh, or 32.1% of the baseline.
- Technical Achievable Potential** modifies Technical Potential by accounting for customer adoption constraints. In Washington, first-year savings potential is 56 GWh, or 1.1% of the baseline. In 2041, cumulative technical achievable savings reach 1,309 GWh, or 21.0% of the baseline projection. This results in average annual savings of 1.0% of the baseline each year. Technical Achievable Potential is approximately 72% of Technical Potential in Washington throughout the forecast horizon. For Idaho, first year savings are 3 GWh or 1.2% of the baseline and by 2041 cumulative technical achievable savings reach 665 GWh, or 22.5% of the baseline. This results in average annual savings of 1% of the baseline each year. In Idaho, Technical Achievable Potential reflects 71% of Technical Potential throughout the forecast horizon.

Table 5-1 Summary of EE Potential (Annual Energy, GWh), Washington

	2022	2023	2024	2031	2041
<b>Baseline projection (GWh)</b>	5,196	5,212	5,229	5,479	6,243
<b>Cumulative Savings (GWh)</b>					
Achievable Technical Potential	56	121	194	868	1,309
Technical Potential	101	209	325	1,247	1,822
<b>Cumulative Savings (aMW)</b>					
Achievable Technical Potential	6	14	22	99	149
Technical Potential	12	24	37	142	208
<b>Cumulative Savings as a % of Baseline</b>					
Achievable Technical Potential	1.1%	2.3%	3.7%	15.8%	21.0%
Technical Potential	2.0%	4.0%	6.2%	22.8%	29.2%

Table 5-2 Summary of EE Potential (Annual Energy, GWh), Idaho

	2022	2023	2024	2031	2041
<b>Baseline projection (GWh)</b>	2,646	2,650	2,653	2,713	2,951
<b>Cumulative Savings (GWh)</b>					
Achievable Technical Potential	33	70	110	448	665
Technical Potential	58	119	183	654	948
<b>Cumulative Savings (aMW)</b>					
Achievable Technical Potential	4	8	13	51	76
Technical Potential	7	14	21	75	108
<b>Cumulative Savings as a % of Baseline</b>					
Achievable Technical Potential	1.2%	2.6%	4.1%	16.5%	22.5%
Technical Potential	2.2%	4.5%	6.9%	24.1%	32.1%



Figure 5-1 Summary of EE Potential as % of Baseline Projection (Annual Energy), Washington

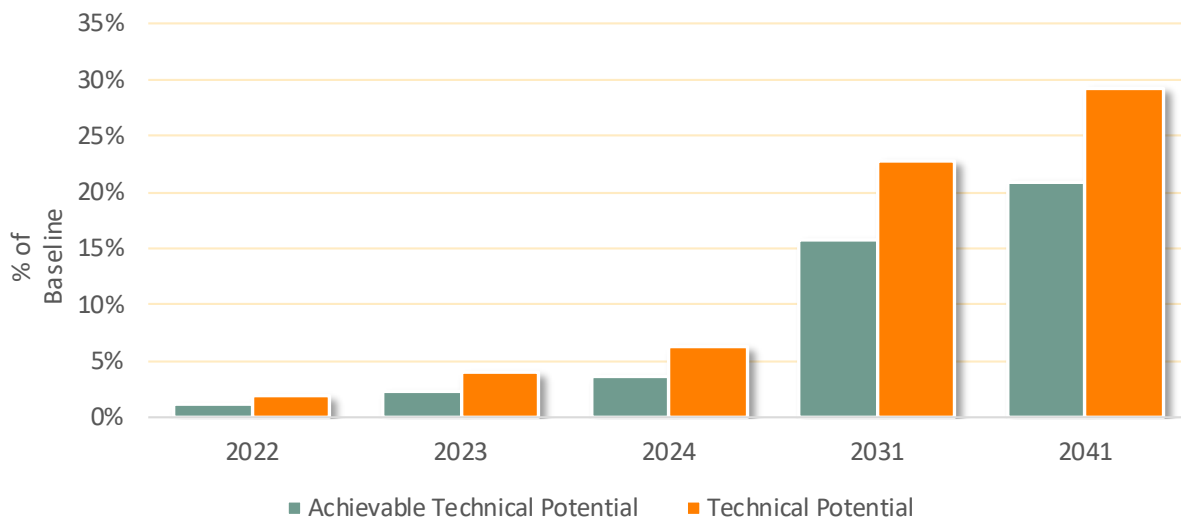

Figure 5-2 Summary of EE Potential as % of Baseline Projection (Annual Energy), Idaho

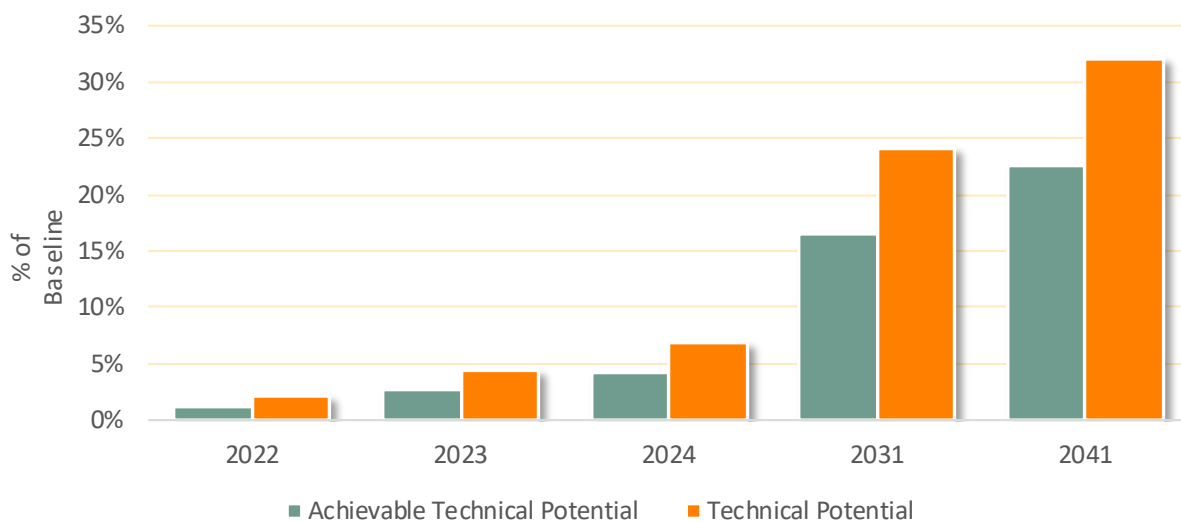

Figure 5-3 Baseline Projection and EE Forecast Summary (Annual Energy, GWh), Washington

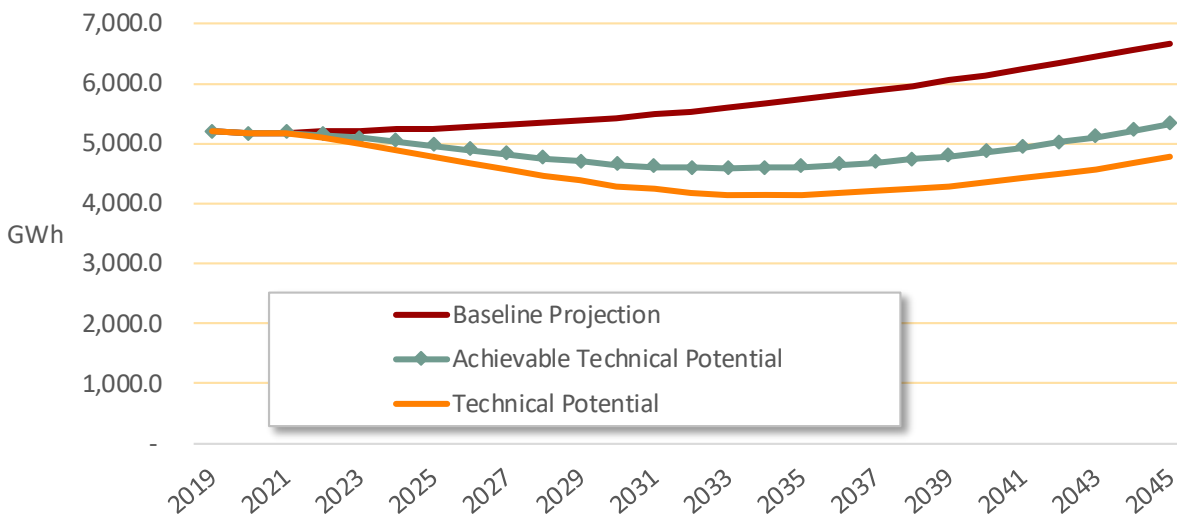
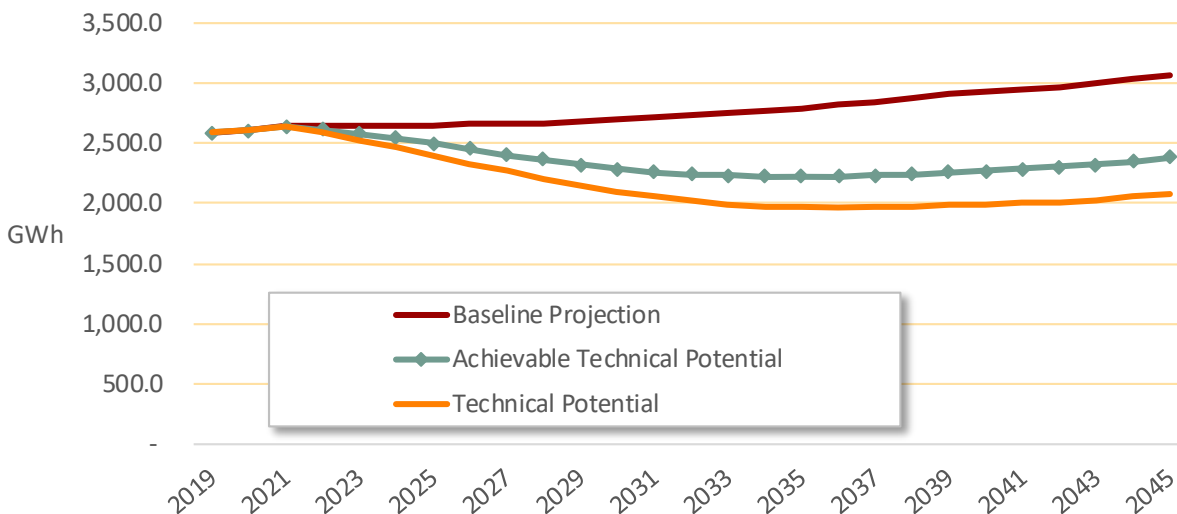

Figure 5-4 Baseline Projection and EE Forecast Summary (Annual Energy, GWh), Idaho



## Summary of Conservation Potential by Sector

Table 5-3 and Figure 5-5 summarize the range of electric Technical Achievable Potential by sector, both states combined. The residential and commercial sectors contribute the most savings, with commercial lighting forming a strong early foundation, and later-blossoming residential potential from measures such as heat pump water heaters growing to surpass commercial savings by years 10-20.

Table 5-3 Technical Achievable Conservation Potential by Sector (Annual Use), WA and ID

	2022	2023	2024	2031	2041
<b>Cumulative Savings (GWh)</b>					
Residential	32	72	120	623	1,004
Commercial	46	97	152	583	819
Industrial	10	21	33	110	151
<b>Total</b>	<b>88</b>	<b>190</b>	<b>304</b>	<b>1,317</b>	<b>1,974</b>
<b>Cumulative Savings (aMW)</b>					
Residential	4	8	14	71	115
Commercial	5	11	17	67	94
Industrial	1	2	4	13	17
<b>Total</b>	<b>10</b>	<b>22</b>	<b>35</b>	<b>150</b>	<b>225</b>

Figure 5-5 Technical Achievable Conservation Potential by Sector (Annual Energy, GWh)

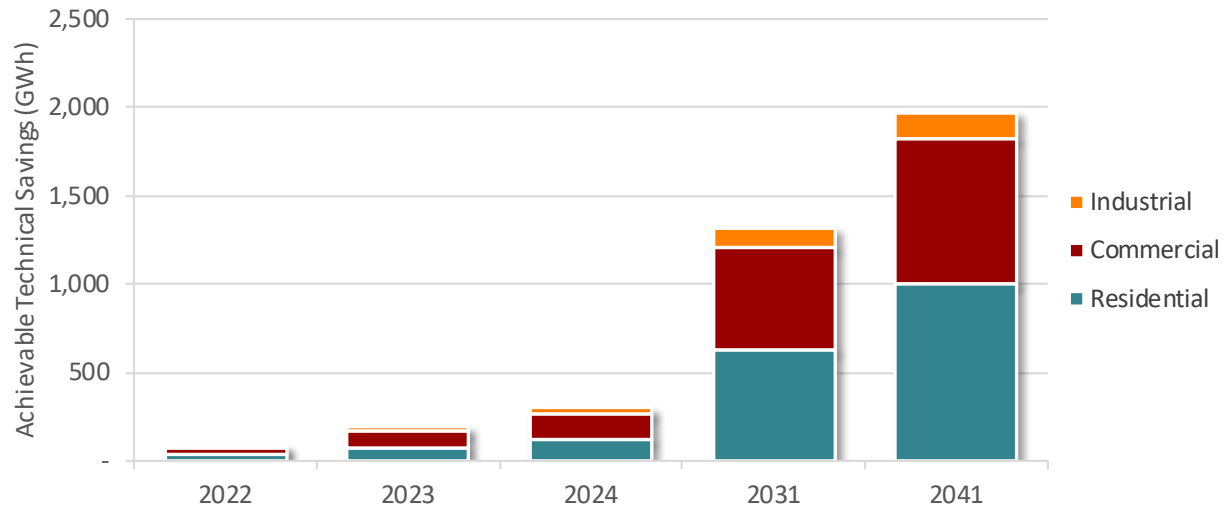

## Residential Conservation Potential

Table 5-4 (WA) and Table 5-5 (ID) present estimates for measure-level conservation potential for the residential sector in terms of annual energy savings. Figure 5-6 (WA) and Figure 5-7 (ID) display the two levels of potential by year. For Washington, Technical Achievable Potential in 2022 is 20 GWh, or 0.8 % of the baseline projection. By 2041, cumulative technical achievable savings are 672 GWh, or 22.6% of the baseline projection. At this level, it represents over 66% of technical potential. For Idaho, 2022 technical achievable savings are 12 GWh or 1.0% of the baseline and by 2040 cumulative technical achievable savings reach 332 GWh, or 21.9% of the baseline. Technical Achievable Potential in Idaho in 2041 is 67% of technical potential.

Table 5-4 Residential Conservation Potential (Annual Energy), Washington

	2022	2023	2024	2031	2041
<b>Baseline projection (GWh)</b>	2,525	2,529	2,534	2,631	2,976
<b>Cumulative Savings (GWh)</b>					
Achievable Technical Potential	20	45	75	409	672
Technical Potential	49	103	162	655	1,005
<b>Cumulative Savings (aMW)</b>					
Achievable Technical Potential	2	5	9	47	77
Technical Potential	6	12	18	75	115
<b>Cumulative Savings as a % of Baseline</b>					
Achievable Technical Potential	0.8%	1.8%	3.0%	15.6%	22.6%
Technical Potential	1.9%	4.1%	6.4%	24.9%	33.8%

Table 5-5 Residential Conservation Potential (Annual Energy), Idaho

	2022	2023	2024	2031	2041
<b>Baseline projection (GWh)</b>	1,250	1,256	1,262	1,322	1,513
<b>Cumulative Savings (GWh)</b>					
Achievable Technical Potential	12	27	45	214	332
Technical Potential	27	56	88	334	494
<b>Cumulative Savings (aMW)</b>					
Achievable Technical Potential	1	3	5	24	38
Technical Potential	3	6	10	38	56
<b>Cumulative Savings as a % of Baseline</b>					
Achievable Technical Potential	1.0%	2.2%	3.5%	16.2%	21.9%
Technical Potential	2.1%	4.5%	6.9%	25.3%	32.6%

Figure 5-6 Residential Conservation Savings as a % of the Baseline Projection (Annual Energy), Washington

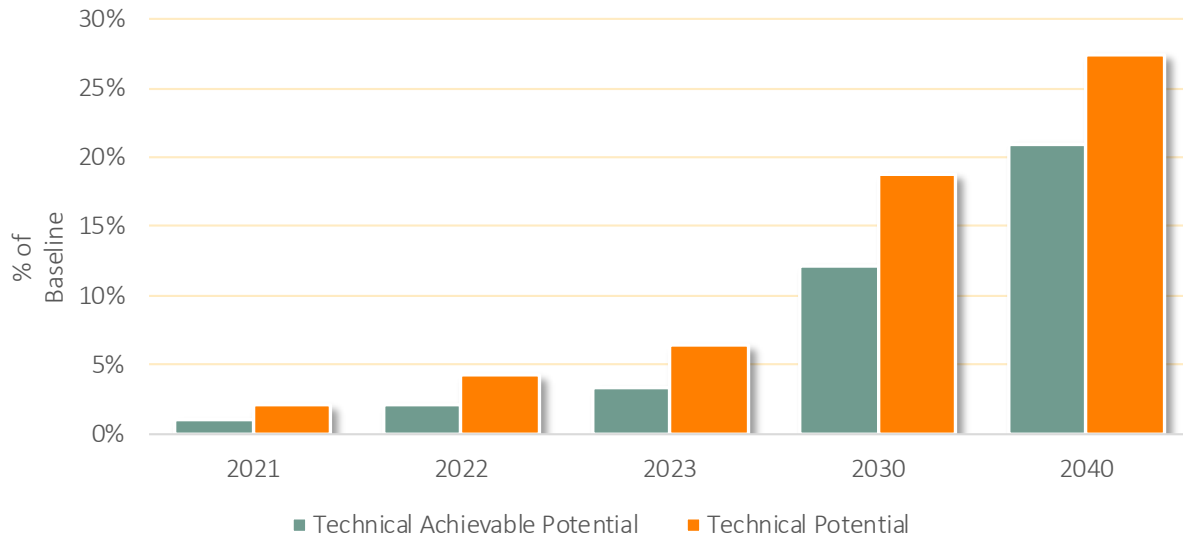
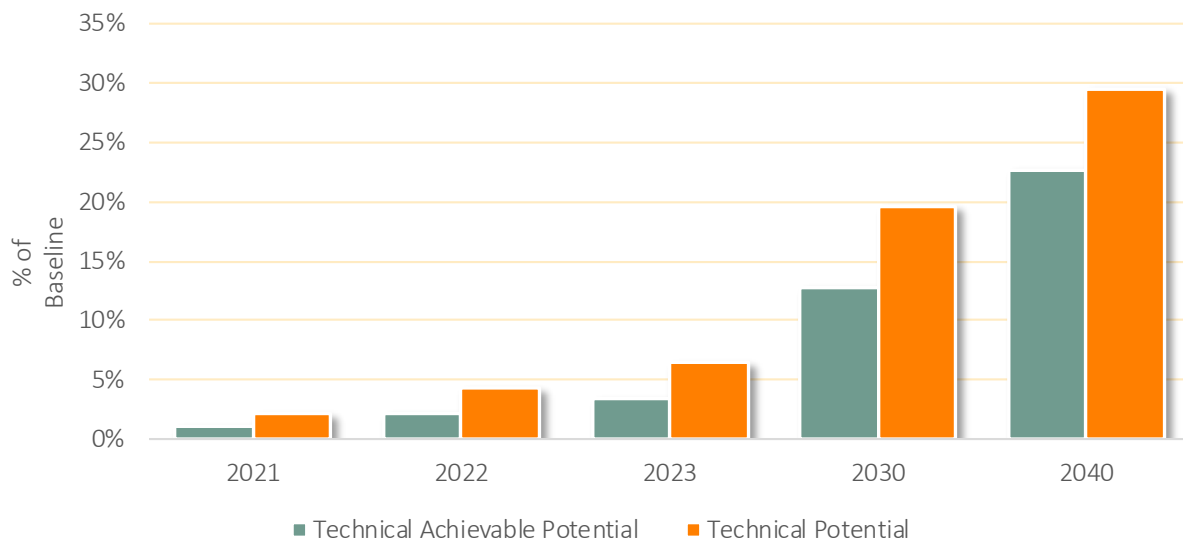

Figure 5-7 Residential Conservation Savings as a % of the Baseline Projection (Annual Energy), Idaho



Below, we present the top residential measures from the perspective of annual energy use. Table 5-6 identifies the top 20 residential measures from the perspective of cumulative technical achievable energy savings potential for Washington in 2023, the second year of potential. The top three measures include ENERGY STAR- Connected Thermostat, Ductless Mini Split Heat Pump (Zonal), and Home Energy Management System (HEMS). Note that technical achievable savings do not screen for cost effectiveness and some measures are expected to be screened out during the IRP process.

Table 5-6 Residential Top Measures in 2023 (Annual Energy, MWh), Washington

Rank	Residential Measure	2023 Cumulative Energy Savings (MWh)	% of Total
1	ENERGY STAR - Connected Thermostat	4,409	10%
2	Ductless Mini Split Heat Pump (Zonal)	4,280	10%
3	Home Energy Management System (HEMS)	3,428	8%
4	Windows - High Efficiency/ENERGY STAR	2,154	5%
5	Water Heater <= 55 Gal	2,016	5%
6	Insulation - Basement Sidewall Installation	1,826	4%
7	Insulation - Ducting	1,563	3%
8	Windows - Low-e Storm Addition	1,519	3%
9	Building Shell - Air Sealing (Infiltration Control)	1,228	3%
10	Ductless Mini Split Heat Pump with Optimized Controls (Ducted Forced Air)	1,128	3%
11	Connected Line-Voltage Thermostat	1,128	3%
12	Exempted Lighting	1,035	2%
13	Interior Lighting - Occupancy Sensors	1,004	2%
14	Exterior Lighting - Photovoltaic Installation	980	2%
15	Insulation - Floor Upgrade	898	2%
16	General Service Lighting	896	2%
17	Building Shell - Whole-Home Aerosol Sealing	840	2%
18	Insulation - Ceiling Upgrade	804	2%
19	Insulation - Wall Cavity Installation	770	2%
20	Windows - Cellular Shades	685	2%
<b>Total of Top 20 Measures</b>		<b>32,591</b>	<b>73%</b>
<b>Total Cumulative Savings</b>		<b>44,799</b>	<b>100%</b>

Figure 5-8 presents forecasts of cumulative energy savings for Washington. Space heating and water heating account for a substantial portion of the savings throughout the forecast horizon. Weatherization, ductless heat pumps, and heat pump water heaters account for a large portion of potential over the 20-year study period. LED lighting, while still present, is reduced in comparison to prior studies, as RTF market baseline assumptions and the Washington state lighting standard have moved a substantial amount of potential from those technologies into the realm of codes and market transformation.

Figure 5-8 Residential Technical Achievable Savings Forecast (Cumulative GWh), Washington

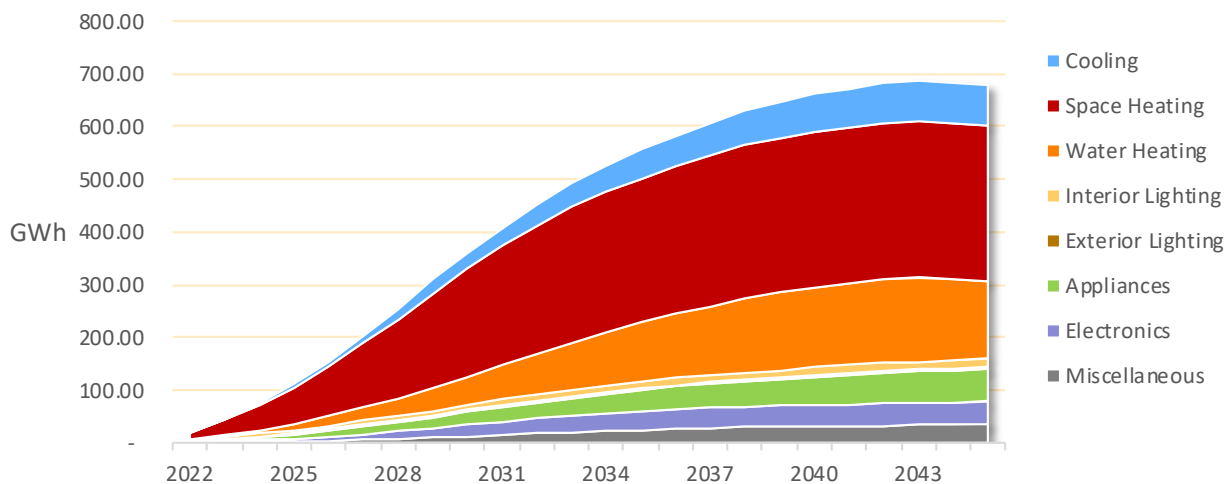

Table 5-7 shows the top residential measures for Idaho in 2023. The top three measures include high efficiency windows, Ductless Mini Split Heat Pump (Zonal), and LEDs in General Service Lighting. Since Idaho does not have the same state standard regarding lighting, LEDs for general service have a greater remaining market of potential captured in the CPA. In Note that technical achievable savings do not screen for cost effectiveness and some measures are expected to be screened out during the IRP process.

Table 5-7 Residential Top Measures in 2022 (Annual Energy, MWh), Idaho

Rank	Residential Measure	2023 Cumulative Energy Savings (MWh)	% of Total
1	Windows - High Efficiency/ENERGY STAR	3,654	13%
2	Ductless Mini Split Heat Pump (Zonal)	2,319	9%
3	General Service Lighting	2,302	8%
4	Home Energy Management System (HEMS)	1,547	6%
5	ENERGY STAR - Connected Thermostat	1,480	5%
6	Windows - Low-e Storm Addition	1,312	5%
7	Insulation - Basement Sidewall Installation	1,107	4%
8	Connected Line-Voltage Thermostat	689	3%
9	Building Shell - Air Sealing (Infiltration Control)	688	3%
10	Water Heater - Faucet Aerators	634	2%
11	Water Heater <= 55 Gal	630	2%
12	Exterior Lighting - Photovoltaic Installation	621	2%
13	Insulation - Ducting	580	2%
14	Insulation - Floor Upgrade	520	2%
15	Interior Lighting - Occupancy Sensors	452	2%
16	Insulation - Wall Cavity Installation	425	2%
17	Insulation - Wall Sheathing	383	1%
18	Insulation - Ceiling Upgrade	376	1%
19	Building Shell - Whole-Home Aerosol Sealing	369	1%
20	Ductless Mini Split Heat Pump with Optimized Controls	357	1%
<b>Total of Top 20 Measures</b>		<b>20,445</b>	<b>75%</b>
<b>Total Cumulative Savings</b>		<b>27,260</b>	<b>100%</b>

Figure 5-9 presents forecasts of cumulative energy savings for Idaho. Results are similar to Washington where the majority of the savings come from heating and water heating measures.



Figure 5-9 Residential Technical Achievable Savings Forecast (Cumulative GWh), Idaho

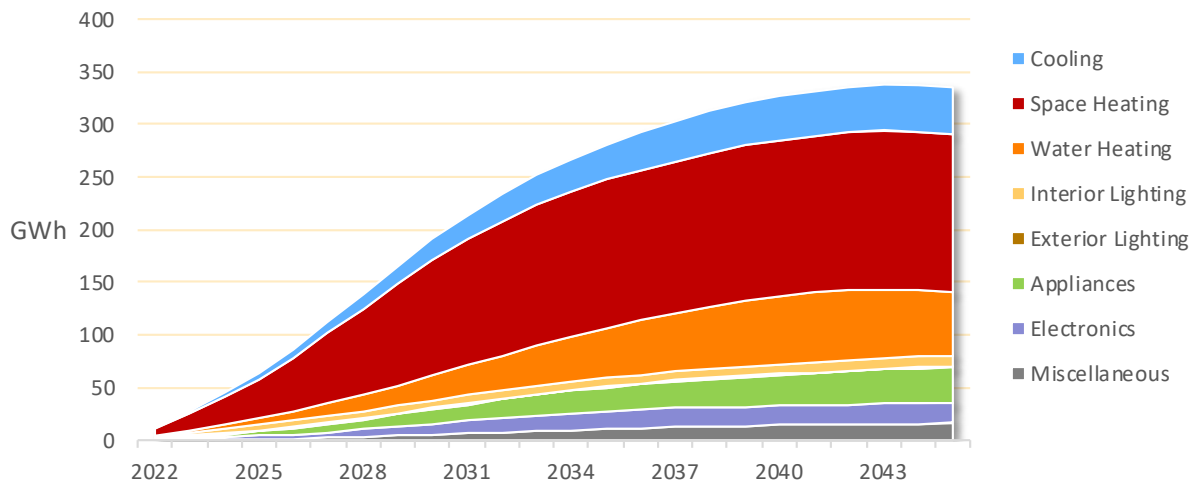

## Commercial Conservation Potential

Table 5-8 (WA) and Table 5-9 (ID) present estimates for the two levels of conservation potential for the commercial sector from the perspective of annual energy savings and average MW.

Table 5-8 Commercial Conservation Potential (Annual Energy), WA

	2022	2023	2024	2031	2041
<b>Baseline projection (GWh)</b>	2,201	2,211	2,224	2,385	2,811
<b>Cumulative Savings (GWh)</b>					
Achievable Technical Potential	30	64	101	397	551
Technical Potential	44	90	139	514	712
<b>Cumulative Savings (aMW)</b>					
Achievable Technical Potential	3	7	12	45	63
Technical Potential	5	10	16	59	81
<b>Cumulative Savings as a % of Baseline</b>					
Achievable Technical Potential	1.4%	2.9%	4.5%	16.6%	19.6%
Technical Potential	2.0%	4.1%	6.3%	21.5%	25.3%

Table 5-9 Commercial Conservation Potential (Annual Energy), Idaho

	2022	2023	2024	2031	2041
<b>Baseline projection (GWh)</b>	1,022	1,023	1,023	1,041	1,112
<b>Cumulative Savings (GWh)</b>					
Achievable Technical Potential	16	33	51	186	268
Technical Potential	25	50	76	260	375
<b>Cumulative Savings (aMW)</b>					
Achievable Technical Potential	2	4	6	21	31
Technical Potential	3	6	9	30	43
<b>Cumulative Savings as a % of Baseline</b>					
Achievable Technical Potential	1.6%	3.2%	5.0%	17.9%	24.1%
Technical Potential	2.5%	4.9%	7.5%	25.0%	33.7%

Figure 5-10 (WA) and Figure 5-11 (ID) display the two levels of potential by year. For Washington, the first year of the projection, Technical Achievable Potential is 30 GWh, or 1.4% of the baseline projection. By 2041, technical achievable savings are 551 GWh, or 19.6% of the baseline projection. Throughout the forecast horizon, Technical Achievable Potential represents about 77% of technical potential. For Idaho, first year technical achievable savings are 16 GWh or 1.6% of the baseline and by 2041, cumulative technical

achievable savings reach 268 GWh, or 24.1% of the baseline. Throughout the forecast horizon, Technical Achievable Potential represents about 71% of technical potential in Idaho.

Figure 5-10 Commercial Conservation Savings (Energy), Washington

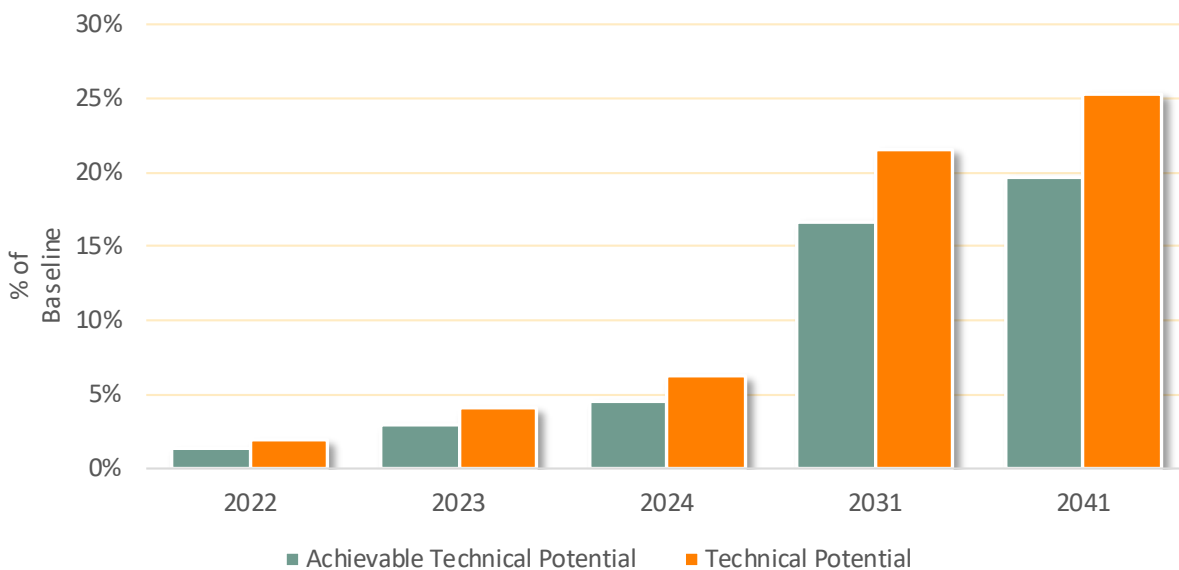
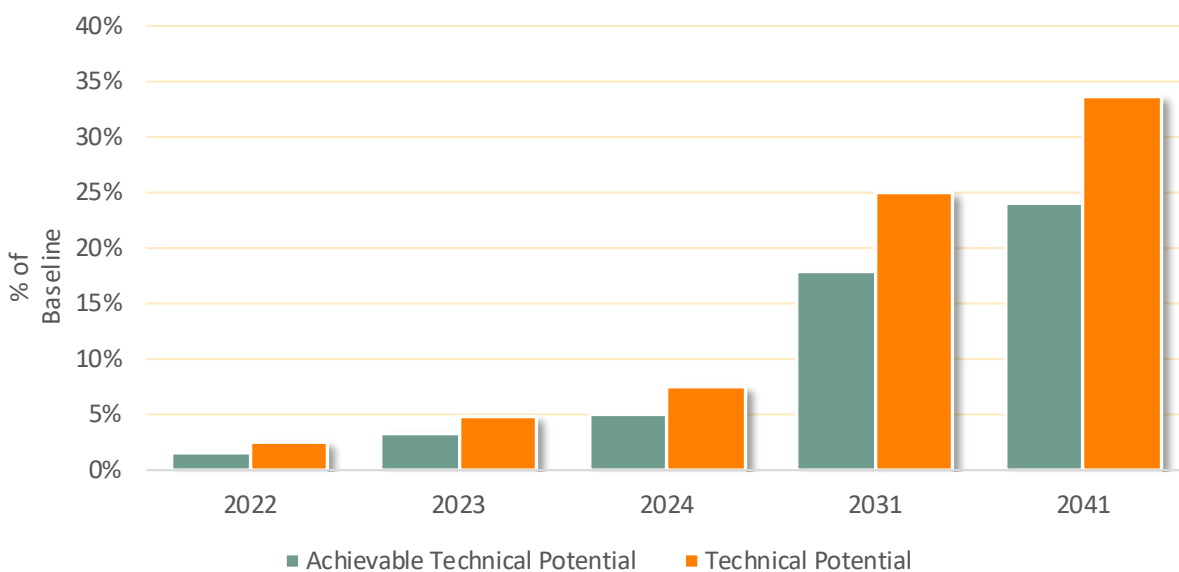

Figure 5-11 Commercial Conservation Savings (Energy), Idaho



Below, we present the top commercial measures from the perspective of annual energy use.

Table 5-10 (WA) and Table 5-11 (ID) identify the top 20 commercial-sector measures from the perspective of annual energy savings in 2019. In both states, lighting applications make up three out of the top five measures. Although the market has seen significant penetration of LEDs in some applications, newer systems – particularly those with built-in occupancy sensors or other controls – still represent significant savings opportunities.

Figure 5-12 (WA) and Figure 5-13 (ID) present forecasts of cumulative energy savings by end use. Lighting savings from interior and exterior applications account for a substantial portion of the savings throughout the forecast horizon, due in part to revised turnover assumptions for C&I lighting consistent with RTF assumptions.

Table 5-5-10 Commercial Top Measures in 2019 (Annual Energy, MWh), Washington

Rank	Commercial Measure	2023 Cumulative Energy Savings (MWh)	% of Total
1	Retrocommissioning	6,538	10%
2	Linear Lighting	5,887	9%
3	Strategic Energy Management	4,771	7%
4	Space Heating - Heat Recovery Ventilator	2,401	4%
5	High-Bay Lighting	2,306	4%
6	General Service Lighting	2,010	3%
7	Chiller - Variable Flow Chilled Water Pump	1,876	3%
8	Exterior Lighting - Photovoltaic Installation	1,857	3%
9	HVAC - Dedicated Outdoor Air System (DOAS)	1,679	3%
10	Interior Lighting - Embedded Fixture Controls	1,568	2%
11	Refrigeration - Evaporative Condenser	1,505	2%
12	Ventilation - Permanent Magnet Synchronous Fan Motor	1,379	2%
13	Thermostat - Connected	1,364	2%
14	Area Lighting	1,317	2%
15	Ventilation - Variable Speed Control	1,084	2%
16	Refrigeration - Variable Speed Compressor	982	2%
17	Ventilation - ECM on VAV Boxes	970	2%
18	RTU - Evaporative Precooler	958	1%
19	HVAC - Economizer Maintenance and Repair	876	1%
20	Water Heater - Solar System	754	1%
<b>Total of Top 20 Measures</b>		<b>42,082</b>	<b>66%</b>
<b>Total Cumulative Savings</b>		<b>64,043</b>	<b>100%</b>

Figure 5-12 Commercial Technical Achievable Savings Forecast (Cumulative GWh), Washington

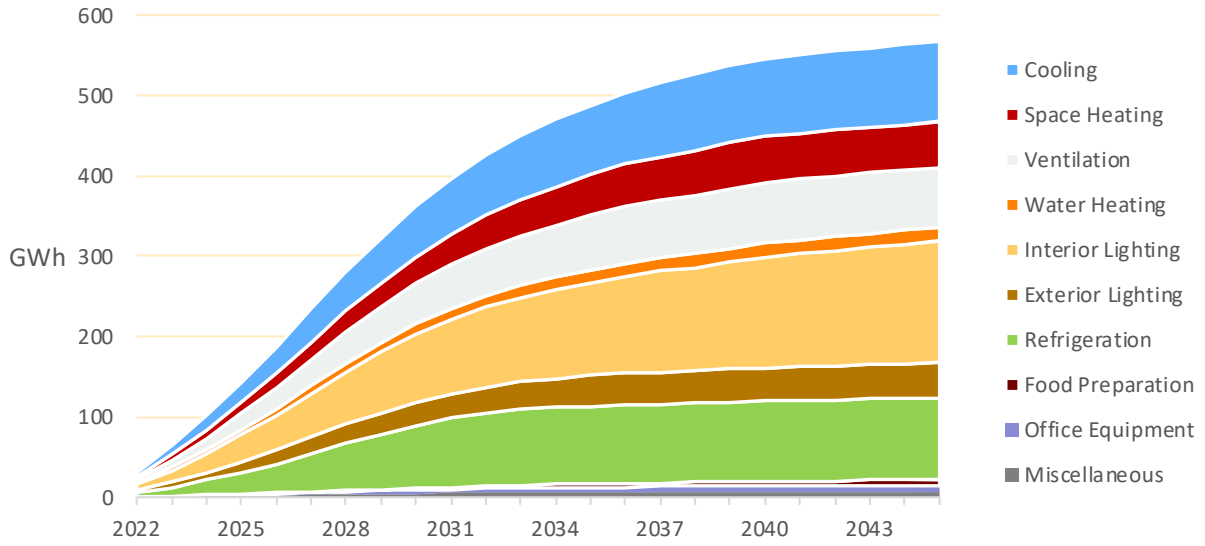
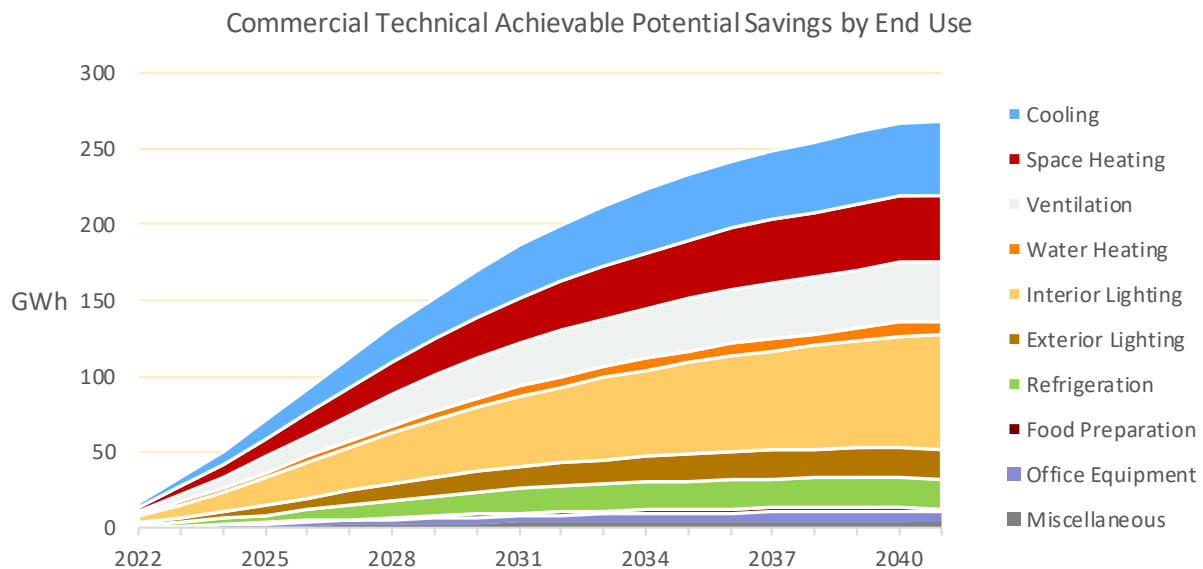

Table 5-11 Commercial Top Measures in 2023 (Annual Energy, MWh), Idaho

Rank	Commercial Measure	2023 Cumulative Energy Savings (MWh)	% of Total
1	Linear Lighting	3,251	10%
2	Retrocommissioning	2,780	8%
3	Space Heating - Heat Recovery Ventilator	2,727	8%
4	Strategic Energy Management	2,276	7%
5	High-Bay Lighting	1,817	6%
6	HVAC - Dedicated Outdoor Air System (DOAS)	1,375	4%
7	General Service Lighting	1,171	4%
8	Ductless Mini Split Heat Pump	1,131	3%
9	Chiller - Variable Flow Chilled Water Pump	1,048	3%
10	Exterior Lighting - Photovoltaic Installation	1,016	3%
11	Interior Lighting - Embedded Fixture Controls	902	3%
12	Area Lighting	882	3%
13	Thermostat - Connected	801	2%
14	Ventilation - Permanent Magnet Synchronous Fan Motor	636	2%
15	Ventilation - Variable Speed Control	508	2%
16	Exterior Lighting - Enhanced Controls	477	1%
17	Office Equipment - Advanced Power Strips	473	1%
18	HVAC - Economizer Maintenance and Repair	470	1%
19	Ventilation - ECM on VAV Boxes	460	1%
20	RTU - Evaporative Precooler	439	1%
<b>Total of Top 20 Measures</b>		<b>24,638</b>	<b>75%</b>
<b>Total Cumulative Savings</b>		<b>32,778</b>	<b>100%</b>

Figure 5-13 Commercial Technical Achievable Savings Forecast (Cumulative GWh), Idaho



## Industrial Conservation Potential

Table 5-12 (WA) and Table 5-13 (ID) present potential estimates at the measure level for the industrial sector, from the perspective of annual energy savings. Figure 5-14 (WA) and Figure 5-15 (ID) display the two levels of potential by year. For Washington, technical achievable savings in the first year, 2022, are 6 GWh, or 1.2% of the baseline projection. In 2041, savings reach 86 GWh, or 18.8% of the baseline projection. For Idaho, technical achievable savings in the first year, 2022, are 4 GWh, or 1.2% of the baseline projection. In 2041, savings reach 65 GWh, or 20.0% of the baseline projection.

Table 5-12 Industrial Conservation Potential (Annual Energy), WA

	2022	2023	2024	2031	2041
<b>Baseline projection (GWh)</b>	471	472	471	463	455
<b>Cumulative Savings (GWh)</b>					
Achievable Technical Potential	6	12	18	62	86
Technical Potential	8	17	25	78	105
<b>Cumulative Savings (aMW)</b>					
Achievable Technical Potential	1	1	2	7	10
Technical Potential	1	2	3	9	12
<b>Cumulative Savings as a % of Baseline</b>					
Achievable Technical Potential	1.2%	2.5%	3.8%	13.4%	18.8%
Technical Potential	1.7%	3.5%	5.2%	16.8%	23.1%

Table 5-13 Industrial Conservation Potential (Annual Energy), Idaho

	2022	2023	2024	2031	2041
<b>Baseline projection (GWh)</b>	374	371	368	349	325
<b>Cumulative Savings (GWh)</b>					
Achievable Technical Potential	4	10	14	49	65
Technical Potential	6	13	19	60	79
<b>Cumulative Savings (aMW)</b>					
Achievable Technical Potential	1	1	2	6	7
Technical Potential	1	1	2	7	9
<b>Cumulative Savings as a % of Baseline</b>					
Achievable Technical Potential	1.2%	2.6%	3.9%	13.9%	20.0%
Technical Potential	1.6%	3.4%	5.2%	17.2%	24.3%

Figure 5-14 Industrial Conservation Potential as a % of the Baseline Projection (Annual Energy), Washington

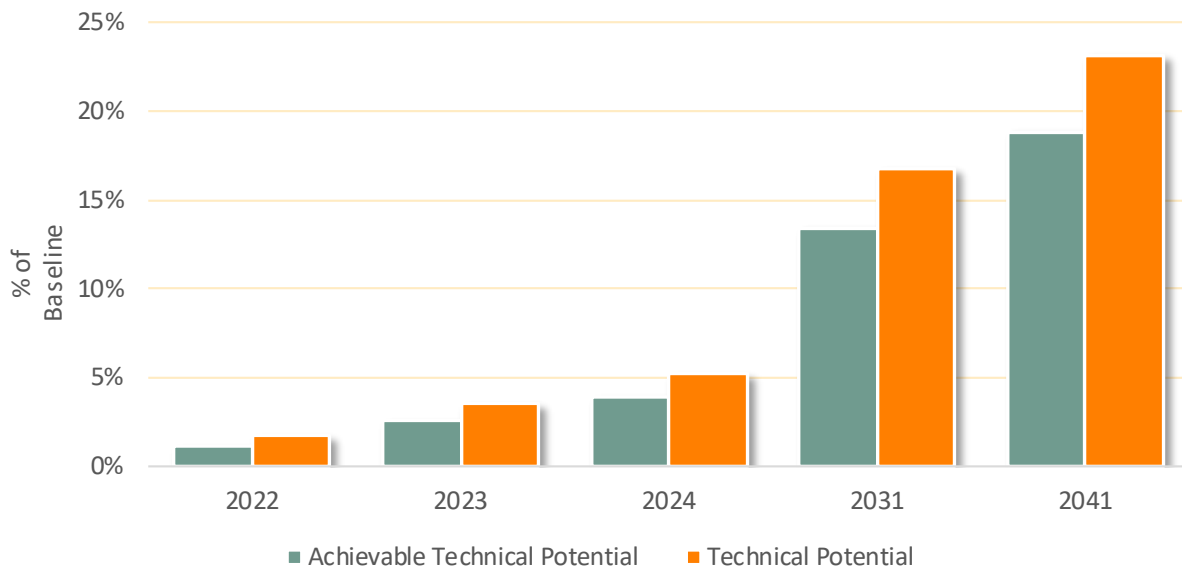
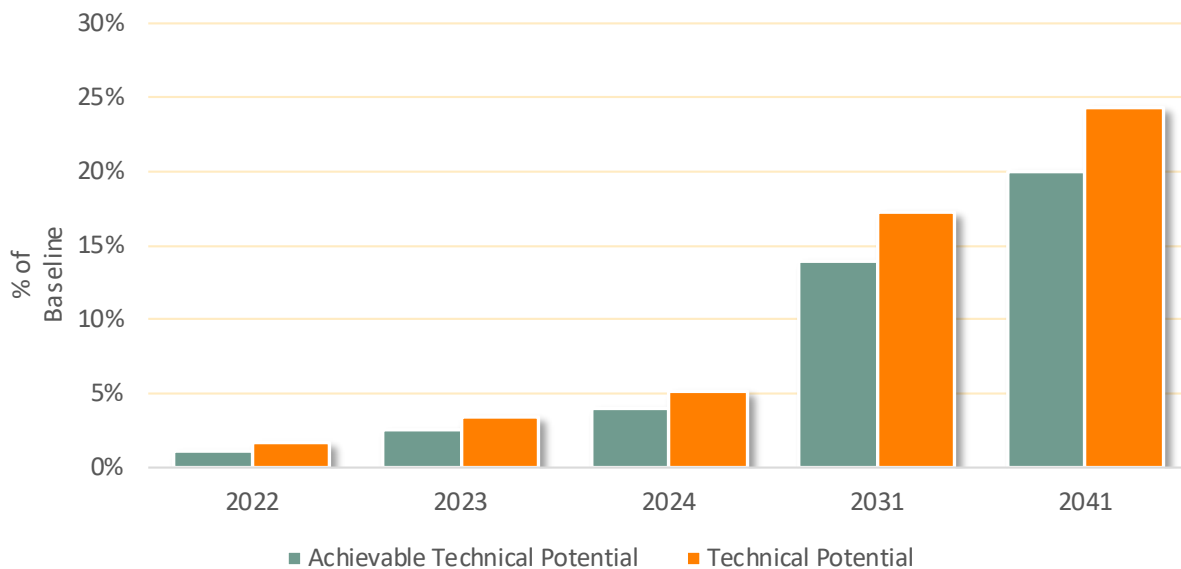



Figure 5-15 Industrial Conservation Potential as a % of the Baseline Projection (Annual Energy), Idaho



Below, we present the top industrial measures from the perspective of annual energy use.

Table 5-14 and Table 5-15 identify the top 20 industrial measures from the perspective of annual energy savings in 2020. For both states, the top measure is High-Bay Lighting. The measure with the second highest savings is Interior Lighting- Embedded Fixture Controls, and retrocomissioning rounds out the top three in both states.

Figure 5-16 (WA) and Figure 5-17 (ID) present forecasts of energy savings by end use as a percent of total annual savings and cumulative savings. Various motor savings and lighting make up the majority of savings potential in the study horizon.

Table 5-14 Industrial Top Measures in 2023 (Annual Energy, GWh), Washington

Rank	Industrial Measure	2023 Cumulative Energy Savings (MWh)	% of Total
1	High-Bay Lighting	3,542	30%
2	Interior Lighting - Embedded Fixture Controls	862	7%
3	Retrocommissioning	740	6%
4	Fan System - Equipment Upgrade	656	5%
5	Strategic Energy Management	613	5%
6	Fan System - Flow Optimization	550	5%
7	Compressed Air - Leak Management Program	379	3%
8	Material Handling - Variable Speed Drive	378	3%
9	Pumping System - System Optimization	342	3%
10	Interior Lighting - Networked Fixture Controls	303	3%
11	Interior Fluorescent - Delamp and Install Reflectors	252	2%
12	Compressed Air - End Use Optimization	246	2%
13	LED Lighting for Indoor Agriculture	236	2%
14	Pumping System - Variable Speed Drive	225	2%
15	Fan System - Variable Speed Drive	215	2%
16	Exterior Lighting - Photovoltaic Installation	205	2%
17	Interior Lighting - Skylights	193	2%
18	Ventilation	179	1%
19	Pumping System - Equipment Upgrade	171	1%
20	Advanced Refrigeration Controls	166	1%
<b>Total of Top 20 Measures</b>		<b>10,454</b>	<b>87%</b>
<b>Total Cumulative Savings</b>		<b>11,959</b>	<b>100%</b>

Figure 5-16 Industrial Technical Achievable Savings Forecast (Cumulative GWh), Washington

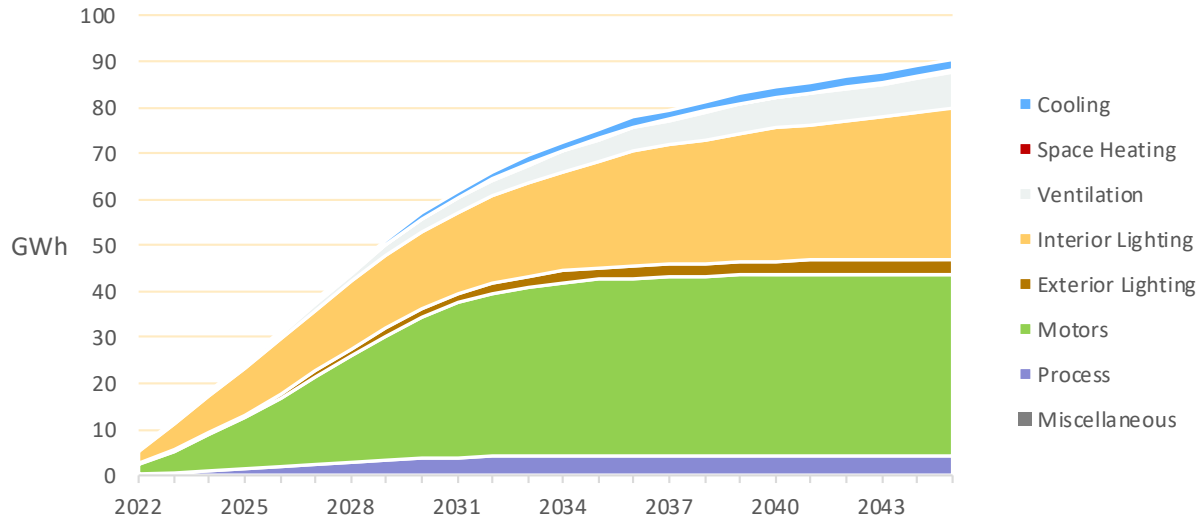
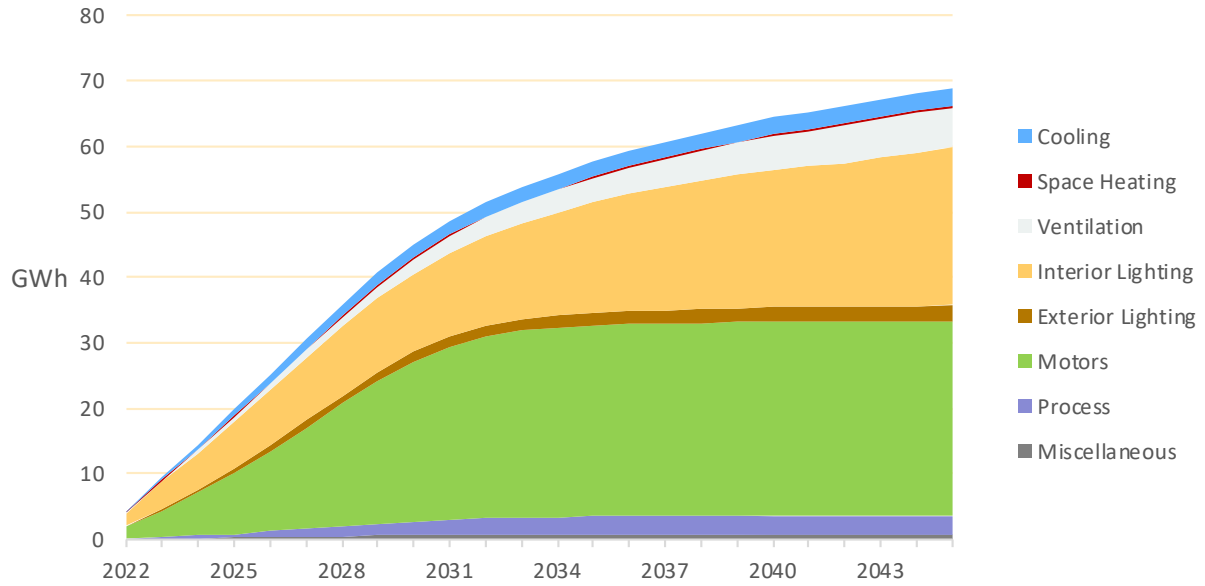

Table 5-15 Industrial Top Measures in 2019 (Annual Energy, GWh), Idaho

Rank	Industrial Measure	2023 Cumulative Energy Savings (MWh)	% of Total
1	High-Bay Lighting	2,514	26%
2	Interior Lighting - Embedded Fixture Controls	613	6%
3	Retrocommissioning	550	6%
4	Fan System - Equipment Upgrade	518	5%
5	Strategic Energy Management	485	5%
6	Fan System - Flow Optimization	435	5%
7	Compressed Air - Equipment Upgrade	396	4%
8	Compressed Air - Leak Management Program	299	3%
9	Material Handling - Variable Speed Drive	299	3%
10	Pumping System - System Optimization	270	3%
11	Destratification Fans (HVLS)	241	3%
12	Interior Lighting - Networked Fixture Controls	215	2%
13	Interior Fluorescent - Delamp and Install Reflectors	199	2%
14	Compressed Air - End Use Optimization	194	2%
15	LED Lighting for Indoor Agriculture	184	2%
16	Pumping System - Variable Speed Drive	178	2%
17	Fan System - Variable Speed Drive	170	2%
18	Exterior Lighting - Photovoltaic Installation	161	2%
19	Pumping System - Equipment Upgrade	135	1%
20	Interior Lighting - Skylights	126	1%
<b>Total of Top 20 Measures</b>		<b>8,184</b>	<b>86%</b>
<b>Total Cumulative Savings</b>		<b>9,510</b>	<b>100%</b>

Figure 5-17 Industrial Technical Achievable Savings Forecast (Annual Energy, GWh), Idaho





## 6

## DEMAND RESPONSE POTENTIAL

In 2014, AEG and The Brattle Group performed an assessment of winter demand response potential for Avista's commercial and industrial (C&I) sectors. As part of this conservation potential assessment, Avista asked AEG to update the DR analysis for C&I sectors in Washington and Idaho. In 2016, AEG provided an update to the 2014 assessment. For the 2019 study, Avista asked that AEG include the demand response potential for their residential sector and since Avista is a dual-peaking utility, AEG was asked to provide summer demand response potential as well. This year for the 2020 study, to achieve a more accurate representation of ancillary services, viable programs were evaluated on an individual basis for ancillary savings potential.

The updated analysis provides demand response potential and cost estimates for the 24-year planning horizon of 2022-2045 to inform the development of Avista's 2021 Integrated Resource Plan (IRP). It primarily seeks to develop reliable estimates of the magnitude, timing, and costs of DR resources likely available to Avista over the 24-year planning horizon. The analysis focuses on resources assumed achievable during the planning horizon, recognizing known market dynamics that may hinder resource acquisition. DR analysis results will also be incorporated into subsequent DR planning and program development efforts.

This section describes our analysis approach and the data sources used to develop potential and cost estimates. The following three steps broadly outline our analysis approach:

1. Segment residential service, general service, large general service, and extra-large general service customers for DR analysis and develop market characteristics (customer count and coincident peak demand values) by segment for the base year and planning period.
2. Identify and describe the relevant DR programs and develop assumptions on key program parameters for potential and cost analysis.
3. Assess achievable potential by DR program for the 2022-2045 planning period and estimate program budgets and levelized costs.

### Market Characterization

The first step in the DR analysis was to segment customers by service class and develop characteristics for each segment. The two relevant characteristics for DR potential analysis are the number of eligible customers in each market segment and their coincident peak demand.

### Market segmentation

Like the 2014, 2016, and 2019 studies, we used Avista's rate schedules as the basis for customer segmentation by state and customer class. Table 6-1 summarizes the market segmentation we developed for this study.

Table 6-1 Market Segmentation

Market Dimensions	Segmentation Variable	Description
1	State	Idaho Washington
2	Customer Class	By rate schedule: Residential Service <b>General Service:</b> Rate Schedule 11 Large General Service: Rate Schedule 21 Extra Large General Service: Rate Schedule 25 <sup>10</sup>

We excluded Avista's two largest industrial customers from our analysis because they are so large and unique that a segment-based modeling approach is not appropriate. To accurately estimate demand reduction potential for these customers, we would need to develop a detailed understanding of their industrial processes and associated possibilities for load reduction. We would also need to develop specific DR potential estimates for each customer. Avista may wish to engage with these large customers directly to gauge interest in participating in DR programs.

### Customer Counts by Segment

Once the customer segments were defined, we developed customer counts and coincident peak demand values for the three C&I segments. We developed these estimates separately by state for Washington and Idaho. We considered 2019 as the base year for the study, since this is the most recent year with a full 12 months of available customer data. This also coincides with the base year used for the CPA study. The forecast years are 2022 to 2045.

Avista provided actual customer counts by rate schedule for Washington and Idaho over the 2016-2019 timeframe and forecasted customer counts over the 2020-2025 period. We used this data to calculate the growth rate across the final two years of the forecast. We then applied these growth rates to develop customer projections over the rest of the study timeframe, 2026-2045. The average annual growth rate for all sectors is 1.1%. Table 6-2 below shows the number of customers by state and customer class for the base year and selected future years.

Table 6-2 Baseline C&amp;I Customer Forecast by State and Customer Class

Customer Class	2022	2025	2035	2045
Washington				
Residential Service	234,948	241,598	264,568	289,722
General Service	23,328	24,029	26,470	29,159
Large General Service	1,847	1,840	1,822	1,808
Extra Large General Service	22	22	22	22
<b>Total</b>	<b>260,146</b>	<b>267,489</b>	<b>292,881</b>	<b>320,712</b>

<sup>10</sup> Excluding the two largest Schedule 25 and Schedule 25P customers.

Customer Class	2022	2025	2035	2045
Idaho				
Residential Service	120,797	125,479	141,680	159,973
General Service	16,897	17,505	19,692	22,158
Large General Service	1,012	1,007	992	982
Extra Large General Service	11	11	11	11
<b>Total</b>	<b>138,717</b>	<b>144,002</b>	<b>162,376</b>	<b>183,124</b>

## Forecasts of Winter and Summer Peak Demand

### System Peak Demand

Avista provided the 2019 system winter and summer peak values as well as annual energy forecasts through 2025. AEG used the growth rate across the final two forecasted years by state and sector to forecast annual peak demands through 2045, Table 6-3 shows the winter and summer system peaks for the base year and selected futures years. These peaks exclude the demand for Avista's largest industrial customers. The winter and summer system peaks are each expected to increase around 10% between 2022-2045.

Table 6-3 Baseline System Winter Peak Forecast (MW @Meter) <sup>11</sup>

Peak Demand	2022	2025	2035	2045
Winter System Peak	1,331	1,349	1,403	1,444
Summer System Peak	1,369	1,389	1,446	1,508

### Coincident Peak Demand by Segment

To develop the coincident peak forecast for each segment, we started with electricity sales by customer class. Avista provided actual electricity sales for the years 2016-2019 and forecasted electricity sales by rate schedule for the years 2020 through 2025. For the remaining years of the forecast, 2026 through 2045, we projected electricity sales using the growth rate from the last two years of each forecast timeframe.

Next, we relied on electricity sales and coincident peak demand values for 2010 provided in the 2010 load research study conducted by Avista to calculate the load factors for Residential Service, General Service, Large General Service, and Extra Large General Service customers for Washington and Idaho. We then applied the load factors to the 2019 electricity sales data to derive coincident peak demand estimates for the four segments. Table 6-4 and Table 6-5 below show the load factors and coincident peak values for the base year and selected future years.

<sup>11</sup> The system peak forecast shown here is the net native load forecast from data provided by Avista, excluding the two largest industrial loads.



Table 6-4 Winter Load Factors and Baseline Coincident Peak Forecast by Segment (MW @Meter)

Customer Class	Load Factor	2022	2025	2035	2045
Washington					
Residential	0.63	473	481	502	522
General Service	0.60	82	85	93	103
Large General Service	0.60	185	184	182	180
Extra Large General Service	0.68	83	83	83	84
<b>Total</b>		<b>823</b>	<b>834</b>	<b>861</b>	<b>889</b>
Idaho					
Residential	0.65	226	232	252	274
General Service	0.66	65	67	75	85
Large General Service	0.66	91	90	87	85
Extra Large General Service	0.60	49	49	47	45
<b>Total</b>		<b>431</b>	<b>437</b>	<b>461</b>	<b>489</b>

Table 6-5 Summer Load Factors and Baseline Coincident Peak Forecast by Segment (MW @Meter)

Customer Class	Load Factor	2022	2025	2035	2045
Washington					
Residential	0.50	509	518	540	562
General Service	0.51	83	85	94	103
Large General Service	0.51	186	185	183	181
Extra Large General Service	0.65	74	74	75	75
<b>Total</b>		<b>852</b>	<b>863</b>	<b>892</b>	<b>922</b>
Idaho					
Residential	0.53	237	243	264	287
General Service	0.57	64	66	75	84
Large General Service	0.57	90	89	86	84
Extra Large General Service	0.53	48	47	45	44
<b>Total</b>		<b>438</b>	<b>445</b>	<b>470</b>	<b>499</b>

## System and Coincident Peak Forecasts by State

The next step in market characterization is to define the estimated peak load forecast for the study timeframe. This is done at the Avista system level, and also by state. We used Avista's peak demand data

| A-4

to develop the individual state contribution to the estimated coincident peak values. These represent a state’s projected demand at the time of the system peak for both summer and winter.

Figure 6-1 shows the statewide contribution to the estimated system coincident summer peak, developed based on load forecast data provided by Avista. In 2022, system peak load for the summer is 1,369 MW at the grid or generator level. Washington contributes 66% of summer system peak while Idaho contributes 34%. Summer coincident peak load is expected to grow by an average of 0.42% annually from 2022-2044.

Figure 6-1 Contribution to Estimated System Coincident Peak Forecast by State (Summer)

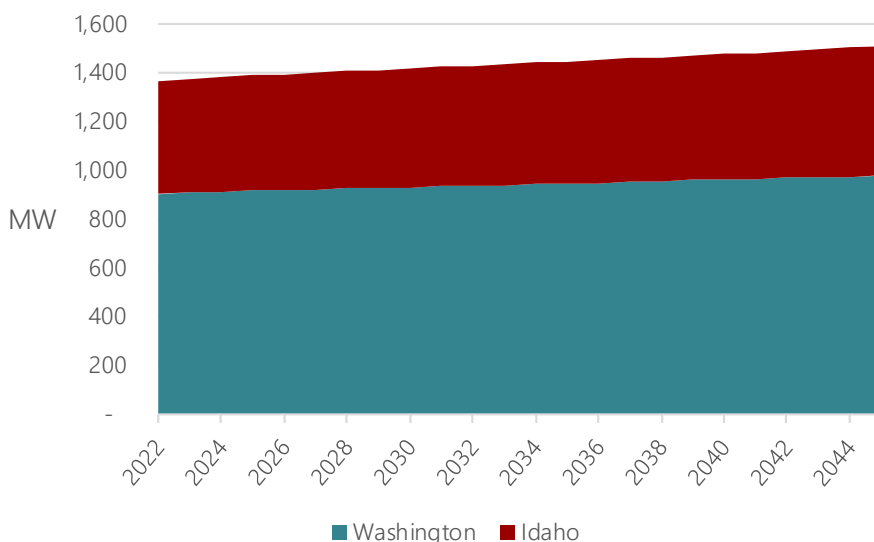
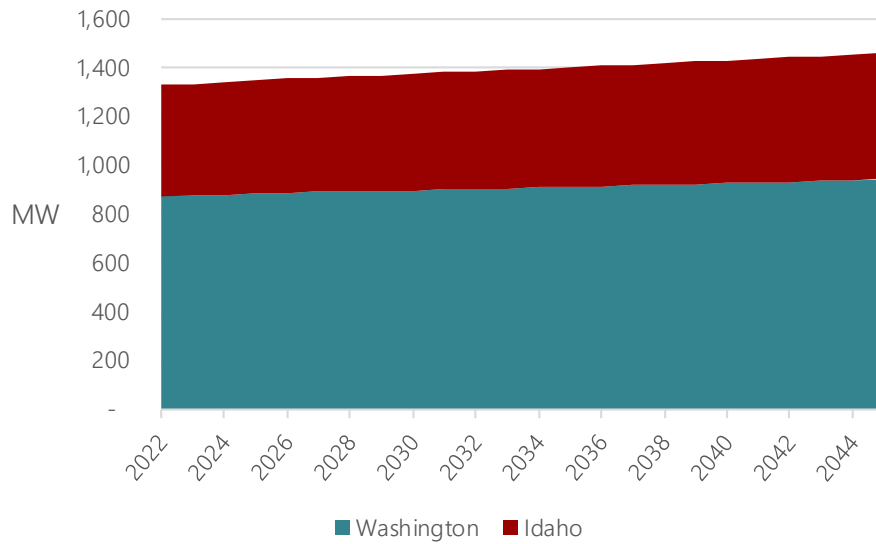

Figure 6-2 shows the jurisdictional contribution to the estimated system coincident winter peak forecast, developed based on load forecast data provided by Avista. In 2022, system peak load for the winter (a typical December weekday at 6:00 pm) is 1,331 MW at the grid or generator level. The winter system peak is about 3% lower than the summer peak. Washington contributes 66% of winter system peak while Idaho contributes 34%. Over the study period, winter coincident peak load is expected to grow by an average of 0.41% annually.

Figure 6-2 Contribution to Estimated System Coincident Peak Forecast by State (Winter)



### Equipment End Use Saturation

Another key component of market characterization for DR analysis is end use saturation data. This is required to further segment the market and identify eligible customers for direct control of different equipment options. The relevant space heating equipment for DR analysis are electric furnaces and air-source heat pumps. We obtained C&I saturation data from the CPA study, which had updated figures from the 2019 NEEA Commercial Building Stock Assessment (CBSA). We obtained Residential saturation data from the 2016 NEEA Residential Building Stock Assessment (RBSA). Table 6-6 and Table 6-7 below show saturation estimates by state and customer class for Washington and Idaho respectively. We assume slight growth trends in Central AC, Space Heating, and Electric Vehicle saturations through 2040. For AMI, Avista began their rollout in Washington in 2019 and expects to complete it by the end of 2020. Currently Avista has 99.5% of their rollout complete in their electric only service areas in Washington. In Idaho, the AMI rollout is projected to begin in 2022 and be complete by 2024.

Table 6-6 2019 End Use Saturations by Customer Class, Washington

End Use Saturation by Equipment Type	Residential	C&I
Space Heating Saturation		
Air-Source Heat Pump	40.8%	14.2%
Total (Applicable for DR Analysis)	40.8%	14.2%
Water Heating Saturation		
CTA-2045 Water Heater	0.0%	0.0%
Electric Vehicle Saturation		
All equipment	0.8%	-
Central AC Saturation		
All Equipment	27.8%	27.8%
AMI Saturation		
All Equipment	2.0%	2.0%
Appliance Saturation		
All Equipment	100.0%	-

Table 6-7 2019 End Use Saturation by Customer Class, Idaho

End Use Saturation by Equipment Type	Residential	C&I
Space Heating Saturation		
Air-Source Heat Pump	40.8%	14.2%
Total (Applicable for DR Analysis)	40.8%	14.2%
Water Heating Saturation		
Electric Resistance Water Heater	52.2%	60.1%
Electric Vehicle Saturation		
All equipment	0.8%	-
Central AC Saturation		
All Equipment	27.8%	27.8%
AMI Saturation		
All Equipment	0.0%	0.0%
Appliance Saturation		
All Equipment	100.0%	-

## DSM Program Options

The next step in the analysis is to characterize the available DSM options for the Avista territory. We considered the characteristics and applicability of a comprehensive list of options available in the DSM marketplace today as well as those projected into the 24-year study time horizon. We included for quantitative analysis those options which have been deployed at scale such that reliable estimates exist for cost, lifetime, and performance. Each selected option is described briefly below.

### Program Descriptions

#### Direct Load Control of Central Air Conditioners

The DLC Central AC program targets Avista's Residential and General Service customers in Washington and Idaho. This program directly controls Central AC load in summer through a load control switch placed on a customer's AC unit. During events, the AC units will be cycled on and off. Participation in the program is expected to be shared with the Smart Thermostat- Cooling Program in the integrated scenario since the programs are similar. However, if only one program is rolled out of the two, then participation would be expected to double for the program implemented. In the fully integrated case, we assume it would take three full time employees to manage all the DLC programs (five total).

#### Direct Load Control of Domestic Hot Water Heaters

The DLC Domestic Hot Water Heater program targets Avista's Residential and General Service customers in Idaho. This program directly controls water heating load throughout the year for these customers through a load control switch. Water heaters would be completely turned off during the DR event period. The event period is assumed to be 50 hours during the summer months and another 50 hours during winter months. Water heaters of all sizes are eligible for control. We assume a \$160 cost to Avista for each switch, a \$200 installation fee, and a permit and license cost of \$100 for residential participants (\$125 for general service participants).

#### CTA-2045 Hot Water Heaters

The CTA-2045 Hot Water Heater program targets Avista's Residential and General Service customers in Washington. These water heaters contain a communicating module interface and can seamlessly fit into a DR program as these become more prevalent in the Avista territory. Idaho is not mandating this equipment yet and therefore this program is only modeled for Washington. Water heaters would be completely turned off during the DR event period. The event period is assumed to be 75 hours during the summer months and another 75 hours during winter months. Water heaters of all sizes are eligible for control. We assume a \$150 cost to Avista for each module as well as an additional provisioning cost of \$100 for each customer (since only 20% of customers will need help provisioning, so we assume a \$20 average provisioning cost.)

#### Smart Thermostats DLC Heating/Cooling

This program uses the two-way communicating ability of smart thermostats to cycle them on and off during events. The Smart Thermostat program targets Avista's Residential and General Service customers in Washington and Idaho. We assume this will be a Bring your own Thermostat program (BYOT) and therefore assume no installation costs to Avista. Since the cooling and heating programs are quite different as far as impact assumptions and participation rates, we modeled them separately. As mentioned in the DLC Central AC program description, participation in the DLC Smart Thermostat Cooling program is expected to be split between the two programs in the integrated scenario.

#### Smart Appliances DLC

| A-8

The Smart Appliances DLC program uses a Wi-Fi hub to connect smart Wi-Fi enabled appliances such as washers, dryers, refrigerators, and water heaters. During events throughout the year, the smart appliances will be cycled on and off. The Smart Appliances DLC program targets Avista's Residential and General Service customers in Washington and Idaho. We assume a low steady-state participation rate of 5% for this program.

### Third Party Contracts

Third Party Contracts are assumed to be available for General Service, Large General Service, and Extra Large General Service customers year-round. For the Large and Extra Large General Service customers, we assume they will engage in firm curtailment. Under this program option, it is assumed that participating customers will agree to reduce demand by a specific amount or curtail their consumption to a predefined level at the time of an event. In return, they receive a fixed incentive payment in the form of capacity credits or reservation payments (typically expressed as \$/kW-month or \$/kW-year). Customers are paid to be on call even though actual load curtailments may not occur. The amount of the capacity payment typically varies with the load commitment level. In addition to the fixed capacity payment, participants typically receive a payment for energy reduction during events. Because it is a firm, contractual arrangement for a specific level of load reduction, enrolled loads represent a firm resource and can be counted toward installed capacity requirements. Penalties may be assessed for under-performance or non-performance. Events may be called on a day-of or day-ahead basis as conditions warrant.

This option is typically delivered by load aggregators and is most attractive for customers with maximum demand greater than 200 kW and flexibility in their operations. Industry experience indicates that aggregation of customers with smaller sized loads is less attractive financially due to lower economies of scale. In addition, customers with 24x7 operations, continuous processes, or with obligations to continue providing service (such as schools and hospitals) are not often good candidates for this option.

For the general service customers, we simulate a demand buyback program. In a demand buyback program, customers volunteer to reduce what they can on a day-ahead or day-of basis during a predefined event window. Customers then receive an energy payment based on their performance during the events.

### Electric Vehicle DLC Smart Chargers

DLC Smart Chargers for Electric Vehicles can be switched off during on-peak hours throughout the year to offset demand to off-peak hours. Avista currently has an Electric Vehicle Supply Equipment (EVSE) pilot program in place for residential, commercial electric vehicle fleets, and workplace charging locations. In 2018, we based our assumptions off of the EVSE pilot results. However, this year Avista revised several program assumptions internally and AEG used those numbers for the study. The program start year was updated to 2024 to reflect technology rollout, the peak reduction was increased, annual O&M Costs were lowered, the Cost of Equipment was lowered, and the annual incentive costs were removed in lieu of a rebate or the utility providing a rate-based charger to participate in the program.

### Time-of-Use Pricing

The Time-of-Use (TOU) pricing rate is a standard rate structure where rates are lower during off-peak hours and higher during peak hours during the day incentivizing participants to shift energy use to periods of lower grid stress. For the TOU rate, there are no events called and the structure does not change during the year. Therefore, it is a good default rate for customers that still offers some load shifting potential. We assume two scenarios for the TOU rate. An opt-in rate where participants will have to choose to go on the

rate and an opt-out rate where participants will automatically be placed on the TOU rate and will need to request a rate change if required. We assume this rate will be available to all service classes.

### **Variable Peak Pricing**

The Variable Peak Pricing (VPP) rate is composed of significantly higher prices during relatively short critical peak periods on event days to encourage customers to reduce their usage. VPP is usually offered in conjunction with a time-of-use rate, which implies at least three time periods: critical peak, on-peak and off-peak. The customer incentive is a more heavily discounted rate during off-peak hours throughout the year (relative a standard TOU rate). Event days are dispatched on relatively short notice (day ahead or day of) typically for a limited number of days during the year. Over time, event-trigger criteria become well-established so that customers can expect events based on hot weather or other factors. Events can also be called during times of system contingencies or emergencies. We assume that this rate will be offered to all service classes

### **Ancillary Services**

Ancillary Services refer to functions that help grid operators maintain a reliable electricity system. Ancillary services maintain the proper flow and direction of electricity, address imbalances between supply and demand, and help the system recover after a power system event. In systems with significant variable renewable energy penetration, additional ancillary services may be required to manage increased variability and uncertainty. We assume ancillary services demand response capabilities can be available in all sectors. This year we modeled individual ancillary programs based on several parent programs: Smart Thermostats- Heating/Cooling, DLC Water Heating, CTA-2045 Water Heating, Electric Vehicle Charging, and Battery Energy Storage.

### **Thermal Energy Storage**

Ice Energy Storage, a type of thermal energy storage, is an emerging technology that is being explored in many peak-shifting applications across the country. This technology involves cooling and freezing water in a storage container so that the energy can be used at a later time for space cooling. More specifically, the freezing water takes advantage of the large amount of latent energy associated with the phase change between ice and liquid water, which will absorb or release a large amount of thermal energy while maintaining a constant temperature at the freezing (or melting) point. An ice energy storage unit turns water into ice during off-peak times when price and demand for electricity is low, typically night time. During the day, at peak times, the stored ice is melted to meet all or some of the building's cooling requirements, allowing air conditioners to operate at reduced loads.

Ice energy storage is primarily being used in non-residential buildings and applications, as modeled in this analysis, but may see expansion in the future to encompass smaller, residential systems as well as emerging grid services for peak shaving and renewable integration. Since the ice energy storage is used for space cooling, we assume this program would be available during the summer months only.

### **Battery Energy Storage**

This program provides the ability to shift peak loads using stored electrochemical energy. Currently the main battery storage equipment uses Lithium-Ion Batteries. They are the most cost-effective battery type on the market today. We assume the battery energy storage option will be available for all service classes with the size and cost of the battery varying depending upon the level of demand of the building.

### **Behavioral**

| A-10

Behavioral DR is structured like traditional demand response interventions, but it does not rely on enabling technologies nor does it offer financial incentives to participants. Participants are notified of an event and simply asked to reduce their consumption during the event window. Generally, notification occurs the day prior to the event and are deployed utilizing a phone call, email, or text message. The next day, customers may receive post-event feedback that includes personalized results and encouragement.

For this analysis, we assumed the Behavioral DR program would be offered as part of a Home Energy Reports program in a typical opt-out scenario. As such, we assume this program would be offered to residential customers only. Avista does not currently have a Home Energy Report program in place. Therefore, the Behavioral program is expected to bear the full cost of the program implementation.

### **Program Assumptions and Characteristics**

Table 6-8 lists the DSM options considered in the study, including the eligible sectors, the mechanism for deployment and the expected annual event hours (summer and winter hours combined if both seasons are considered). The 2018 study revised the 2016 study by adding Space Heating as an additional option, however Avista ultimately decided the Smart Thermostat DLC Heating program would be sufficient for DLC space heating options. For cooling, both Central AC DLC and Smart Thermostats DLC were considered as options. 2018 was also the first year that the CTA-2045 Water Heaters were considered as an option. In 2020, several other changes were made to provide a more realistic forecast of DR potential. Since CTA-2045 Water Heaters are only being mandated in Washington, we used a DLC Water Heating program for Idaho instead. Real Time Pricing was removed as a rate option as it is becoming more of a rarely implemented program. In addition, ancillary services were broken out this year as subsets of viable parent programs to capture a more accurate depiction of their potential savings.



Table 6-8 Class 1 DSM Products Assessed in the Study

DSM Option	Eligible Sectors	Mechanism	Annual Event Hours
DLC of central air conditioners	Residential, General Service	Direct load control switch installed on customer's equipment.	100
DLC of domestic hot water heaters (DHW)	Residential, General Service	Direct load control switch installed on customer's equipment.	100
CTA-2045 hot water heaters	Residential, General Service	Communicating module installed on water heater	150
Smart Thermostats DLC Heating	Residential, General Service	Internet-enabled control of thermostat set points	36
Smart Thermostats DLC Cooling	Residential, General Service	Internet-enabled control of thermostat set points	36
Smart Appliances DLC	Residential, General Service	Internet-enabled control of operational cycles of white goods appliances	1056
Thermal Energy Storage	General Service, Large General Service, Extra Large General Service	Peak shifting of space cooling loads using stored ice	72
Third Party Contracts	General Service, Large General Service, Extra Large General Service	Customers enact their customized, mandatory curtailment plan. Penalties apply for non-performance.	60
Electric Vehicle DLC Smart Chargers	Residential	Automated, level 2 EV chargers that postpone or curtail charging during peak hours.	1056
Time-of-Use Pricing	All Sectors	Higher rate for a particular block of hours that occurs every day. Requires either on/off peak meters or AMI technology.	1056
Variable Peak Pricing	All Sectors	Much higher rate for a particular block of hours that occurs only on event days. Requires AMI technology.	80
Ancillary Services	All Sectors	Automated control of various building management systems or end-uses through one of the mechanisms already described	varies by program
Thermal Energy Storage	General Service, Large General Service, Extra Large General Service	Peak shifting of primarily space cooling or heating loads using a thermal storage medium such as water or ice	72
Battery Energy Storage	All Sectors	Peak shifting of loads using stored electrochemical energy	72
Behavioral	Residential	Voluntary DR reductions in response to behavioral messaging. Example programs exist in CA and other states. Requires AMI technology.	80

| A-12

The description of options below includes the key assumptions used for potential and levelized cost calculations. The development of these assumptions is based on findings from research and review of available information on the topic, including national program survey databases, evaluation studies, program reports, regulatory filings. The key parameters required to estimate potential for a DSM program are participation rate, per participant load reduction and program costs. We have described below our assumptions of these parameters.

### Participation Rate Assumptions

Table 6-9 below shows the steady-state participation rate assumptions for each DSM option as well as the basis for the assumptions. As previously mentioned, the participation for space cooling is split between DLC Central AC and Smart Thermostat options.

Table 6-9 DSM Steady-State Participation Rates (% of eligible customers)

DSM Option	Residential Service	General Service	Large General Service	Extra Large General Service	Basis for Assumption
Direct Load Control (DLC) of central air conditioners	10%	10%	-	-	NWPC DLC Switch cooling assumption
DLC of domestic hot water heaters (DHW)	15%	5%	-	-	Industry Experience- Brattle Study
Smart Thermostats DLC Heating	5%	3%	-	-	Agreed Upon Estimate with Avista
CTA-2045 hot water heaters	50%	50%	-	-	NWPC Grid Interactive Water Heater Assumptions
Smart Thermostats DLC Cooling	20%	20%	-	-	NWPC Smart Thermostat cooling assumption (See DLC Central AC)
Smart Appliances DLC	5%	5%	-	-	2017 ISACA IT Risk Reward Barometer – US Consumer Results, October 2017
Third Party Contracts	-	15%	22%	21%	Industry Experience
Electric Vehicle DLC Smart Chargers	25%	-	-	-	NWPC Electric Resistance Grid-Ready Summer/Winter Participation
Time-of-Use Pricing Opt-in	13%	13%	13%	13%	Best estimate based on industry experience; Winter impacts ½ of summer impacts
Time-of-Use Pricing Opt-out	74%	74%	74%	74%	
Variable Peak Pricing	25%	25%	25%	25%	OG&E 2019 Smart Hours Study

| A-13

Avista Conservation Potential Assessment for 2022-2045 | Market Profiles

Thermal Energy Storage	-	0.5%	1.5%	1.5%	Industry Experience
Battery Energy Storage	0.5%	0.5%	0.5%	0.5%	Industry Experience
Behavioral	20%	-	-	-	PG&E rollout with six waves (2017)

## Load Reduction Assumptions

Table 6-10 presents the per participant load reductions for each DSM option and explains the basis for these assumptions. The load reductions are shown on a kW basis for technology-based options and a percent load reduction otherwise.

Table 6-10 DSM Per Participant Impact Assumptions

DSM Option	Residential	General Service	Large General Service	Extra Large General Service	Basis for Assumption
Direct Load Control (DLC) of central air conditioners	0.5 kW	1.25 kW	-	-	NWPC DLC Switch cooling assumption was close to 1.0 kW reduced to adjust for Avista proposed cycling strategy,
DLC of domestic hot water heating (DHW)	0.50 kW	1.26 kW	-	-	NWPC Electric Resistance Switch Summer Impact, General Service is 2.52x that of Residential based on DLC Central AC Residential to C&I ratio
CTA-2045 Water Heating	0.50 kW	1.26 kW	-	-	NWPC Electric Resistance Grid-Ready Summer/Winter Impact, General Service is 2.52x that of Residential based on DLC Central AC Residential to C&I ratio
Smart Thermostats DLC Heating	1.09 kW	1.35 kW	-	-	NWPC Smart thermostat heating assumption (east)
Smart Thermostats DLC Cooling	0.50 kW	1.25 kW	-	-	NWPC DLC Switch cooling assumption was close to 1.0 kW reduced to adjust for Avista proposed cycling strategy
Smart Appliances DLC	0.14 kW	0.14 kW	-	-	Ghatikar, Rish. Demand Response Automation in Appliance and Equipment. Lawrence Berkley National Laboratory, 2017.
Third Party Contracts	-	10%	21%	21%	Impact Estimates from Aggregator Programs in California (Source: 2012 Statewide Load Impact Evaluation of California Aggregator Demand Response Programs Volume 1: Ex post and Ex ante Load Impacts; Christensen Associates Energy Consulting; April 1, 2013).
Electric Vehicle DLC Smart Chargers	0.50 kW	-	-	-	Avista EVSE DR Pilot Program and other Avista research
Time-of-Use Pricing Opt-in	5.7%	0.2%	2.6%	3.1%	Best estimate based on industry experience; Winter impacts ½ of summer impacts
Time-of-Use Pricing Opt-out	3.4%	0.2%	2.6%	3.1%	
Variable Peak Pricing	10%	4%	4%	4%	OG&E 2019 Smart Hours Study; Summer Impacts Shown (Winter impacts ¾ summer)

| A-15

DSM Option	Residential	General Service	Large General Service	Extra Large General Service	Basis for Assumption
Thermal Energy Storage		1.68 kW	8.4 kW	8.4 kW	Ice Bear Tech Specifications, <a href="https://www.ice-energy.com/wp-content/uploads/2016/03/ICE-BEAR-30-Product-Sheet.pdf">https://www.ice-energy.com/wp-content/uploads/2016/03/ICE-BEAR-30-Product-Sheet.pdf</a>
Battery Energy Storage	2 kW	2 kW	15 kW	15 kW	Typical Battery size per segment
Behavioral	2%	-	-	-	Opower documentation for BDR with Consumers and Detroit Energy

## Program Costs

Table 6-11 shows the annual marketing, recruitment, incentives, and program development costs associated with each DSM option.

Table 6-12 presents itemized cost assumptions for the DSM Options and the basis for the assumptions for the state of Washington. Table 6-11 shows the annual O&M costs per participant and per MW (Third Party Contracts only) and the Cost of Equipment and installation per participant and per kW (Thermal Energy Storage only).

Table 6-11 DSM Program Operations Maintenance, and Equipment Costs (Washington)

DSM Option	Annual O&M Cost Per Participant	Annual O&M Cost per MW	Cost of Equip + Install Per Participant	Cost of Equip + Install per kW
DLC Central AC	\$13.00		\$260.00	\$0.00
DLC Water Heating	\$23.63		\$472.50	\$0.00
CTA-2045 Water Heating	\$0.00		\$170.00	\$0.00
DLC Smart Thermostats – Heating	\$44.00		\$0.00	\$0.00
DLC Smart Thermostats - Cooling	\$44.00		\$0.00	\$0.00
DLC Smart Appliances	\$0.00		\$300.00	\$0.00
Third Party Contracts	\$0.00	\$80,000.00	\$0.00	\$0.00
DLC Electric Vehicle Charging	\$11.00		\$1,200.00	\$0.00
Time-of-Use Opt-in	\$0.00		\$0.00	\$0.00
Time-of-Use Opt-out	\$0.00		\$0.00	\$0.00
Variable Peak Pricing Rates	\$0.00		\$0.00	\$0.00
Thermal Energy Storage	\$308.00		\$0.00	\$6,160.00
Battery Energy Storage	\$0.00		\$27,897.60	\$0.00
Behavioral	\$3.25		\$0.00	\$0.00

Table 6-12 shows the annual marketing, recruitment, incentives, and program development costs associated with each DSM option.

Table 6-12 Marketing, Recruitment, Incentive, and Development Costs (Washington)

DSM Option	Annual Marketing/Recruitment Cost Per Participant	Annual Incentive Per Participant	Program Development Cost
DLC Central AC	\$67.50	\$29.00	\$23,863.32
CTA-2045 Water Heating	\$67.50	\$24.00	\$75,000.00
DLC Smart Thermostats - Heating	\$67.50	\$20.00	\$23,963.15
DLC Smart Thermostats - Cooling	\$67.50	\$20.00	\$23,863.32
DLC Smart Appliances	\$50.00	\$0.00	\$24,084.70
Third Party Contracts	\$0.00	\$0.00	\$0.00
DLC Electric Vehicle Charging	\$50.00	\$24.00	\$49,135.60
Time-of-Use Opt-in	\$57.50	\$0.00	\$12,315.14
Time-of-Use Opt-out	\$57.50	\$0.00	\$12,281.26
Variable Peak Pricing Rates	\$175.00	\$0.00	\$12,222.26
Thermal Energy Storage	\$100.00	\$0.00	\$14,994.78
Battery Energy Storage	\$25.00	\$0.00	\$8,017.36
Behavioral	\$0.00	\$0.00	\$66,055.68

Table 6-13 and Table 6-14 present the equivalent cost tables for the state of Idaho.

Table 6-13 DSM Program Operations Maintenance, and Equipment Costs (Idaho)

DSM Option	Annual O&M Cost Per Participant	Annual O&M Cost per MW	Cost of Equip + Install Per Participant	Cost of Equip + Install per kW
DLC Central AC	\$13.00		\$260.00	\$0.00
DLC Water Heating	\$23.63		\$472.50	\$0.00
DLC Smart Thermostats – Heating	\$44.00		\$0.00	\$0.00
DLC Smart Thermostats - Cooling	\$44.00		\$0.00	\$0.00
DLC Smart Appliances	\$0.00		\$300.00	\$0.00
Third Party Contracts	\$0.00	\$80,000.00	\$0.00	\$0.00
DLC Electric Vehicle Charging	\$11.00		\$1,200.00	\$0.00
Time-of-Use Opt-in	\$0.00		\$0.00	\$0.00
Time-of-Use Opt-out	\$0.00		\$0.00	\$0.00
Variable Peak Pricing Rates	\$0.00		\$0.00	\$0.00
Thermal Energy Storage	\$308.00		\$0.00	\$6,160.00

| A-17

Battery Energy Storage	\$0.00	\$27,897.60	\$0.00
Behavioral	\$3.25	\$0.00	\$0.00

Table 6-14 Marketing, Recruitment, Incentive, and Development Costs (Idaho)

DSM Option	Annual Marketing/Recruitment Cost Per Participant	Annual Incentive Per Participant	Program Development Cost
DLC Central AC	\$67.50	\$29.00	\$13,636.68
DLC Water Heating	\$67.50	\$24.00	\$13,371.11
DLC Smart Thermostats - Heating	\$67.50	\$20.00	\$13,536.85
DLC Smart Thermostats - Cooling	\$67.50	\$20.00	\$13,636.68
DLC Smart Appliances	\$50.00	\$0.00	\$13,415.30
Third Party Contracts	\$0.00	\$0.00	\$0.00
DLC Electric Vehicle Charging	\$50.00	\$24.00	\$25,864.40
Time-of-Use Opt-in	\$69.00	\$0.00	\$6,434.86
Time-of-Use Opt-out	\$69.00	\$0.00	\$6,468.74
Variable Peak Pricing Rates	\$175.00	\$0.00	\$6,527.74
Thermal Energy Storage	\$100.00	\$0.00	\$10,005.22
Battery Energy Storage	\$25.00	\$0.00	\$4,482.64
Behavioral	\$0.00	\$0.00	\$33,944.32

### Other Cross-cutting Assumptions

In addition to the above program-specific assumptions, there are three that affect all programs:

- **Discount rate.** We used a nominal discount rate of 5.21% to calculate the net present value (NPV) of costs over the useful life of each DR program. All cost results are shown in nominal dollars.
- **Line losses.** Avista provided a line loss factor of 6.16% to convert estimated demand savings at the customer meter level to demand savings at the generator level. In the next section, we report our analysis results at the generator level.
- **Shifting and Saving.** Each program varies in the way energy is shifted or saved throughout the day. For example, customers on the DLC Central AC program are likely to pre-cool their homes prior to the event and turn their AC units back on after the event (snapback effect). The results in this report only show the savings during the event window and not before and after the event. However, shifting and savings assumptions were provided to Avista for each program to inform the IRP results.

| A-18

## DR Potential and Cost Estimates

This section presents analysis results on demand savings and cost estimates for DR programs. We developed savings estimates in two ways:

- First, we present the integrated results. If Avista offers more than one program, then the potential for double counting exists. To address this possibility, we created a participation hierarchy to define the order in which the programs are taken by customers. Then we computed the savings and costs under this scenario. For this study, we assumed a customer would not be on both a Central AC program and a Smart Thermostat program and would only be on a thermal energy storage program or battery energy storage program. The hierarchy of pricing rates is as follows: Time-of-Use, Variable Peak Pricing, and Real Time Pricing.
- At the very end of this section, we present high-level standalone results in 2045 without considering the integrated effects that occur if more than one DR option is offered to Avista customers. Standalone results represent an upper bound for each program individually and should not be added together as that would overstate the overall system level potential.

All potential results presented in this section represent capacity savings in terms of equivalent generation capacity.

### Integrated Potential Results

The following sections separate out the integrated potential results for winter and summer for the Time-of-Use Opt-in and Time-of-Use Opt-out scenarios.

#### *Winter TOU Opt-in Scenario*

Figure 6-3 and Table 6-15 show the total winter demand savings from individual DR options for selected years of the analysis. These savings represent integrated savings from all available DR options in Avista's Washington and Idaho service territories.

Key findings include:

- The highest potential option is CTA-2045 WH which is expected to reach a savings potential of 48.9 MW by 2045.
- The next three biggest potential options in winter include DLC Electric Vehicle Charging (30.2 MW in 2045), Third Part Contracts (21.9 MW), and Variable Peak Pricing Rates (12.0 MW)
- Since most of the participants are likely to be on the VPP pricing rate in the TOU Opt-in scenario, the TOU potential (4.1 MW in 2045) is significantly lower than in the Opt-out case (17.8 MW).
- The total potential savings in the winter TOU Opt-in scenario are expected to increase from 9.3 MW in 2022 to 144.3 MW by 2045. The respective increase in the percentage of system peak goes from 0.7% in 2022 to 10.0% by 2045.



Figure 6-3 Summary of Potential Analysis for Avista (TOU Opt-In Winter Peak MW @Generator)

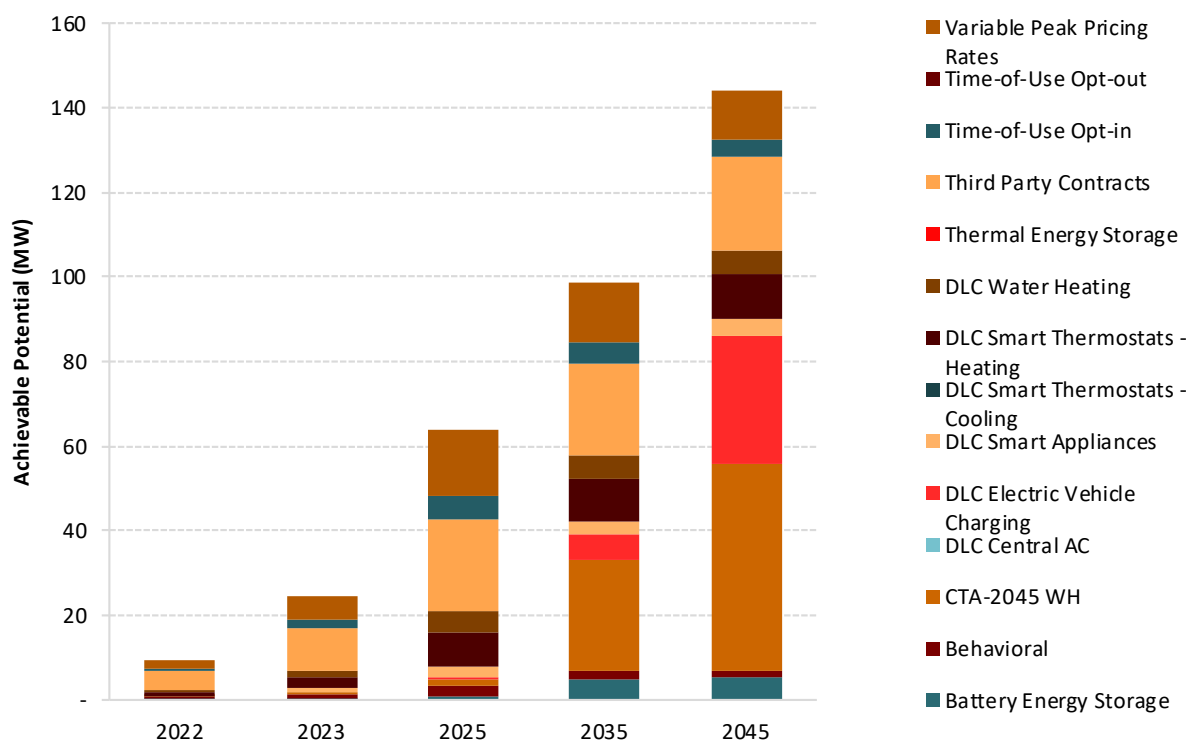

Table 6-15 Achievable DR Potential by Option (TOU Opt-In Winter MW @Generator)

	2022	2023	2025	2035	2045
<b>Total System Peak (MW)</b>	<b>1,331</b>	<b>1,337</b>	<b>1,349</b>	<b>1,403</b>	<b>1,444</b>
<b>Market Potential (MW)</b>	<b>9.3</b>	<b>24.6</b>	<b>63.9</b>	<b>98.8</b>	<b>144.3</b>
<b>Market Potential (% of baseline)</b>	<b>0.7%</b>	<b>1.8%</b>	<b>4.7%</b>	<b>7.0%</b>	<b>10.0%</b>
<b>Potential Forecast</b>	<b>1,321</b>	<b>1,312</b>	<b>1,285</b>	<b>1,304</b>	<b>1,300</b>
<b>Achievable Potential (MW)</b>					
Battery Energy Storage	0.1	0.2	0.7	5.0	5.6
Behavioral	0.6	1.2	2.5	2.0	1.6
CTA-2045 WH	0.1	0.3	1.7	26.3	48.9
DLC Central AC	-	-	-	-	-
DLC Electric Vehicle Charging	-	-	0.3	5.6	30.2
DLC Smart Appliances	0.3	0.9	2.7	3.3	3.7
DLC Smart Thermostats - Cooling	-	-	-	-	-
DLC Smart Thermostats - Heating	0.9	2.6	8.0	9.8	10.9
DLC Water Heating	0.5	1.6	4.9	5.5	5.5
Thermal Energy Storage	-	-	-	-	-
Third Party Contracts	4.6	10.0	21.9	21.8	21.9
Time-of-Use Opt-in	0.5	1.8	5.3	4.9	4.1

| A-20

## Avista Conservation Potential Assessment for 2022-2045 | Market Profiles

Time-of-Use Opt-out	-	-	-	-	-
Variable Peak Pricing Rates	1.8	5.9	15.9	14.5	12.0
<b>Achievable Potential (% of Baseline)</b>					
Battery Energy Storage	0.01%	0.02%	0.05%	0.36%	0.38%
Behavioral	0.04%	0.09%	0.18%	0.14%	0.11%
CTA-2045 WH	0.00%	0.02%	0.12%	1.88%	3.38%
<b>DLC Central AC</b>					
DLC Electric Vehicle Charging			0.02%	0.40%	2.09%
DLC Smart Appliances	0.02%	0.07%	0.20%	0.24%	0.26%
<b>DLC Smart Thermostats - Cooling</b>					
DLC Smart Thermostats - Heating	0.06%	0.19%	0.59%	0.70%	0.75%
DLC Water Heating	0.04%	0.12%	0.37%	0.39%	0.38%
<b>Thermal Energy Storage</b>					
Third Party Contracts	0.34%	0.75%	1.62%	1.56%	1.52%
Time-of-Use Opt-in	0.04%	0.13%	0.39%	0.35%	0.28%
<b>Time-of-Use Opt-out</b>					
Variable Peak Pricing Rates	0.14%	0.44%	1.18%	1.03%	0.83%

Table 6-16 and Table 6-17 show demand savings by individual DR option for the states of Washington and Idaho separately. Using the available DSM options, Washington is projected to save 105.27 MW (7.2% of winter system peak demand) by 2045 while Idaho is projected to save 39.03 MW (2.67% of winter system peak demand) by 2045.

Table 6-16 Achievable DR Potential by Option for Washington (TOU Opt-In Winter MW @Generator)

	2022	2023	2025	2035	2045
<b>Total System Peak (MW)</b>	1,331	1,337	1,349	1,403	1,463
<b>Market Potential (MW)</b>	6.91	16.53	39.46	69.22	105.27
<b>Market Potential (% of System Peak)</b>	0.5%	1.2%	2.9%	4.9%	7.2%
<b>Achievable Potential (MW)</b>					
Battery Energy Storage	0.06	0.18	0.48	3.25	3.54
Behavioral	0.49	0.94	1.69	1.21	0.82
CTA-2045 WH	0.05	0.33	1.67	26.33	48.86
DLC Central AC	-	-	-	-	-
DLC Electric Vehicle Charging	-	-	0.20	3.65	19.47
DLC Smart Appliances	0.19	0.58	1.77	2.15	2.35
DLC Smart Thermostats - Cooling	-	-	-	-	-
DLC Smart Thermostats - Heating	0.57	1.71	5.23	6.37	6.97
DLC Water Heating	-	-	-	-	-
Thermal Energy Storage	-	-	-	-	-

| A-21

## Avista Conservation Potential Assessment for 2022-2045 | Market Profiles

Third Party Contracts	3.55	7.10	14.20	14.23	14.31
Time-of-Use Opt-in	0.46	1.34	3.57	3.07	2.32
Time-of-Use Opt-out	-	-	-	-	-
Variable Peak Pricing Rates	1.54	4.36	10.66	8.96	6.63

Table 6-17 Achievable DR Potential by Option for Idaho (TOU Opt-In Winter MW @Generator)

	2022	2023	2025	2035	2045
<b>Total System Peak (MW)</b>	<b>1,331</b>	<b>1,337</b>	<b>1,349</b>	<b>1,403</b>	<b>1,463</b>
<b>Market Potential (MW)</b>	<b>2.43</b>	<b>8.09</b>	<b>24.43</b>	<b>29.63</b>	<b>39.03</b>
<b>Market Potential (% of System Peak)</b>	<b>0.18%</b>	<b>0.61%</b>	<b>1.81%</b>	<b>2.11%</b>	<b>2.67%</b>
<b>Achievable Potential (MW)</b>					
Battery Energy Storage	0.01	0.06	0.26	1.80	2.02
Behavioral	0.08	0.30	0.79	0.76	0.74
CTA-2045 WH	-	-	-	-	-
DLC Central AC	-	-	-	-	-
DLC Electric Vehicle Charging	-	-	0.11	1.95	10.75
DLC Smart Appliances	0.10	0.31	0.95	1.19	1.35
DLC Smart Thermostats - Cooling	-	-	-	-	-
DLC Smart Thermostats - Heating	0.29	0.89	2.74	3.44	3.89
DLC Water Heating	0.55	1.64	4.93	5.49	5.52
Thermal Energy Storage	-	-	-	-	-
Third Party Contracts	1.02	2.93	7.69	7.60	7.58
Time-of-Use Opt-in	0.09	0.45	1.72	1.84	1.79
Time-of-Use Opt-out	-	-	-	-	-
Variable Peak Pricing Rates	0.29	1.50	5.25	5.55	5.39

### Cost Results

Table 6-18 presents the levelized costs per kW of equivalent generation capacity over 2022-2031 for both Washington and Idaho as well as the system weighted average levelized costs across both states. In addition, we show the 2031 savings potential from DR options for reference purposes.

Key findings include:

- The Third Party Contracts option delivers the highest savings in 2031 at approximately \$75.26/kW-year cost. Capacity-based and energy-based payments to the third-party constitutes the major cost component for this option. All O&M and administrative costs are expected to be incurred by the representative third party contractor.

- The Variable Peak Pricing option has lowest levelized cost among all the DR options. It delivers 16.14 MW of savings in 2031 at \$39.34/kW-year system wide. Enabling technology purchase and installation costs for enhancing customer response is a large part of CPP deployment costs.

Table 6-18 DR Program Costs and Potential (TOU Opt-In Winter)

DR Option	WA	ID	System Wtd Avg Levelized \$/kW (2022-2031)	System Winter Potential MW in Year 2031
Battery Energy Storage	\$833.17	\$849.86	\$839.87	2.81
Behavioral	\$158.42	\$172.77	\$161.07	2.26
CTA-2045 WH	\$174.13		\$174.13	17.36
DLC Central AC				-
DLC Electric Vehicle Charging	\$449.91	\$452.04	\$450.67	2.85
DLC Smart Appliances	\$398.04	\$401.96	\$399.70	3.21
DLC Smart Thermostats - Cooling				-
DLC Smart Thermostats - Heating	\$76.79	\$77.74	\$77.19	9.42
DLC Water Heating		\$239.74	\$239.74	5.48
Thermal Energy Storage				-
Third Party Contracts	\$75.36	\$75.07	\$75.26	21.83
Time-of-Use Opt-in	\$78.12	\$97.73	\$84.82	5.46
Time-of-Use Opt-out				-
Variable Peak Pricing Rates	\$38.26	\$40.90	\$39.34	16.14

### Winter TOU Opt-out Scenario

Figure 6-4 and Table 6-19 show the total winter demand savings from individual DR options for selected years of the analysis. These savings represent integrated savings from all available DR options in Avista's Washington and Idaho service territories.

Key findings include:

- Once again the largest potential is in CTA-2045 WH, at 48.9 MW by 2045.
- After CTA-2045 WH, the next three biggest potential options in winter include DLC Electric Vehicle Charging (30.2 MW in 2045), Third Party Contracts (21.9 MW), and TOU (17.8 MW).
- In the TOU opt-out scenario, customers are placed on the Time-of-Use rate by default and will need to go through an added step to switch rates. Therefore, the majority of savings among the rates are concentrated in TOU which is expected to reach 17.8 MW by 2045.
- In the Opt-out scenario, most of the participants are likely to be on the TOU pricing rate and we see a much lower savings potential for the VPP rate (4.0 MW by 2045).

- The total potential savings in the winter TOU Opt-out scenario are expected to increase from 36.4 MW in 2022 to 150.1 MW by 2045. The respective increase in the percentage of system peak increases from 2.7% in 2022 to 10.4% by 2045.

Figure 6-4 Summary of Winter Potential Analysis for Avista (TOU Opt-Out MW @Generator)

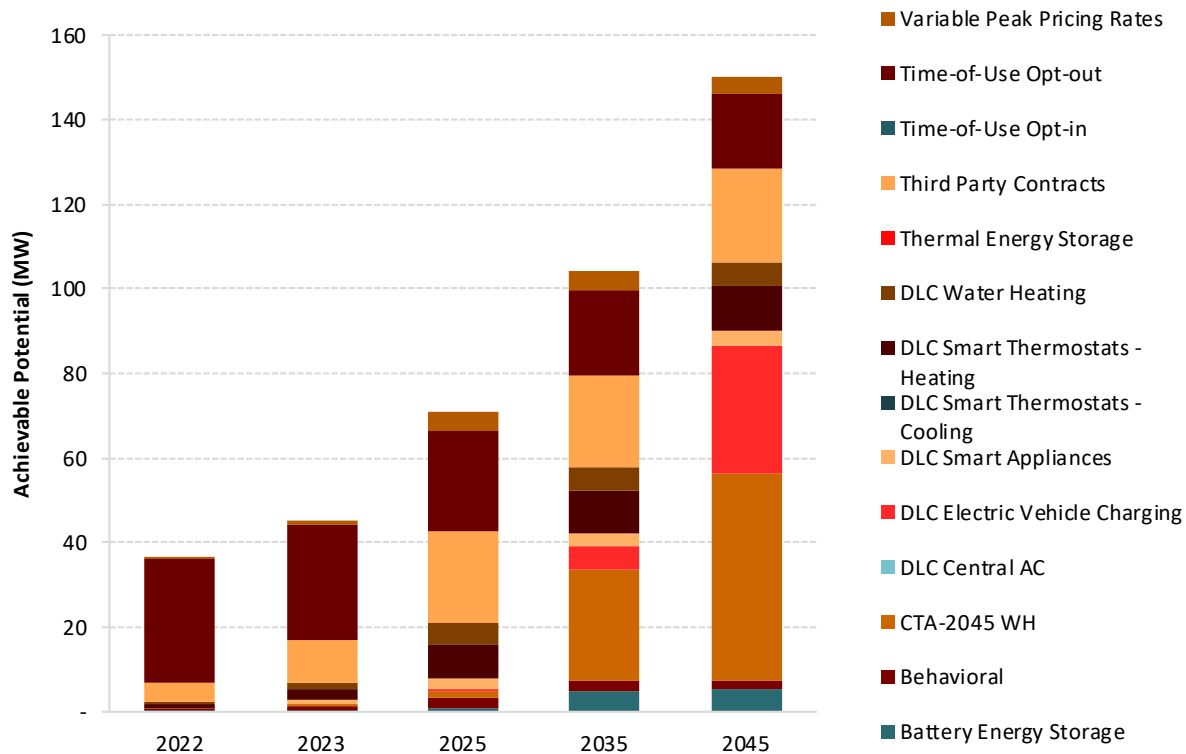

Table 6-19 Achievable DR Potential by Option – TOU Opt-Out (Winter MW @Generator)

	2022	2023	2025	2035	2045
<b>Total System Peak (MW)</b>	1,331	1,337	1,349	1,403	1,444
<b>Market Potential (MW)</b>	36.4	45.3	71.1	104.5	150.1
<b>Market Potential (% of baseline)</b>	2.7%	3.4%	5.3%	7.4%	10.4%
<b>Potential Forecast</b>	1,294	1,291	1,278	1,299	1,294
<b>Achievable Potential (MW)</b>					
Battery Energy Storage	0.1	0.2	0.7	5.0	5.6
Behavioral	0.6	1.3	2.5	2.1	1.7
CTA-2045 WH	0.1	0.3	1.7	26.3	48.9
DLC Central AC	-	-	-	-	-
DLC Electric Vehicle Charging	-	-	0.3	5.6	30.2
DLC Smart Appliances	0.3	0.9	2.7	3.3	3.7

## Avista Conservation Potential Assessment for 2022-2045 | Market Profiles

DLC Smart Thermostats - Cooling	-	-	-	-	-
DLC Smart Thermostats - Heating	0.9	2.6	8.0	9.8	10.9
DLC Water Heating	0.5	1.6	4.9	5.5	5.5
Thermal Energy Storage	-	-	-	-	-
Third Party Contracts	4.6	10.0	21.9	21.8	21.9
Time-of-Use Opt-in	-	-	-	-	-
Time-of-Use Opt-out	29.3	27.0	23.7	20.3	17.8
Variable Peak Pricing Rates	0.2	1.3	4.6	4.7	4.0
<b>Achievable Potential (% of Baseline)</b>					
Battery Energy Storage	0.01%	0.02%	0.05%	0.36%	0.38%
Behavioral	0.04%	0.09%	0.19%	0.15%	0.12%
CTA-2045 WH	0.00%	0.02%	0.12%	1.88%	3.38%
<b>DLC Central AC</b>					
DLC Electric Vehicle Charging			0.02%	0.40%	2.09%
DLC Smart Appliances	0.02%	0.07%	0.20%	0.24%	0.26%
<b>DLC Smart Thermostats - Cooling</b>					
DLC Smart Thermostats - Heating	0.06%	0.19%	0.59%	0.70%	0.75%
DLC Water Heating	0.04%	0.12%	0.37%	0.39%	0.38%
<b>Thermal Energy Storage</b>					
Third Party Contracts	0.34%	0.75%	1.62%	1.56%	1.52%
<b>Time-of-Use Opt-in</b>					
Time-of-Use Opt-out	2.20%	2.02%	1.76%	1.44%	1.23%
Variable Peak Pricing Rates	0.01%	0.10%	0.34%	0.33%	0.28%

Table 6-20 and Table 6-21 show demand savings by individual DR option for the states of Washington and Idaho separately.

Table 6-20 Achievable DR Potential by Option for Washington - TOU Opt-Out (MW @Generator)

	2022	2023	2025	2035	2045
<b>Total System Peak (MW)</b>	<b>1,331</b>	<b>1,337</b>	<b>1,349</b>	<b>1,403</b>	<b>1,463</b>
<b>Market Potential (MW)</b>	<b>29.20</b>	<b>31.62</b>	<b>44.49</b>	<b>73.31</b>	<b>109.61</b>
<b>Market Potential (% of System Peak)</b>	<b>2.2%</b>	<b>2.4%</b>	<b>3.3%</b>	<b>5.2%</b>	<b>7.5%</b>
<b>Achievable Potential (MW)</b>					
Battery Energy Storage	0.06	0.18	0.48	3.25	3.54
Behavioral	0.49	0.95	1.75	1.34	0.99

| A-25

## Avista Conservation Potential Assessment for 2022-2045 | Market Profiles

CTA-2045 WH	0.05	0.33	1.67	26.33	48.86
DLC Central AC	-	-	-	-	-
DLC Electric Vehicle Charging	-	-	0.20	3.65	19.47
DLC Smart Appliances	0.19	0.58	1.77	2.15	2.35
DLC Smart Thermostats - Cooling	-	-	-	-	-
DLC Smart Thermostats - Heating	0.57	1.71	5.23	6.37	6.97
DLC Water Heating	-	-	-	-	-
Thermal Energy Storage	-	-	-	-	-
Time-of-Use Opt-out	24.29	20.07	16.07	13.05	10.79
Variable Peak Pricing Rates	0.02	0.71	3.13	2.95	2.32

Table 6-21 Achievable DR Potential by Option for Idaho – TOU Opt-Out (MW @Generator)

	2022	2023	2025	2035	2045
<b>Total System Peak (MW)</b>	<b>1,331</b>	<b>1,337</b>	<b>1,349</b>	<b>1,403</b>	<b>1,463</b>
<b>Market Potential (MW)</b>	<b>7.22</b>	<b>13.71</b>	<b>26.58</b>	<b>31.14</b>	<b>40.49</b>
<b>Market Potential (% of System Peak)</b>	<b>0.54%</b>	<b>1.03%</b>	<b>1.97%</b>	<b>2.22%</b>	<b>2.77%</b>
<b>Achievable Potential (MW)</b>					
Battery Energy Storage	0.01	0.06	0.26	1.80	2.02
Behavioral	0.08	0.30	0.79	0.76	0.74
CTA-2045 WH	-	-	-	-	-
DLC Central AC	-	-	-	-	-
DLC Electric Vehicle Charging	-	-	0.11	1.95	10.75
DLC Smart Appliances	0.10	0.31	0.95	1.19	1.35
DLC Smart Thermostats - Cooling	-	-	-	-	-
DLC Smart Thermostats - Heating	0.29	0.89	2.74	3.44	3.89
DLC Water Heating	0.55	1.64	4.93	5.49	5.52
Thermal Energy Storage	-	-	-	-	-
Time-of-Use Opt-out	5.00	6.93	7.62	7.20	6.99
Variable Peak Pricing Rates	0.16	0.64	1.49	1.70	1.66

### Cost Results

Table 6-22 presents the levelized costs per kW of equivalent generation capacity over 2022-2031 for both Washington and Idaho as well as the system weighted average levelized costs across both states. In addition, we show the 2031 savings potential from DR options for reference purposes.

Key findings include:

| A-26

- The Third Party Contracts option delivers the highest savings potential of 21.83 MW in 2031 at approximately \$75.26/kW-year cost. Capacity-based and energy-based payments to the third-party constitutes the major cost component for this option. All O&M and administrative costs are expected to be incurred by the representative third party contractor.
- The TOU Opt-out option has the second highest potential to contribute 21.34 MW of savings in 2031 at approximately \$99.84/kW-year
- The Variable Peak Pricing option has lowest levelized cost among all the DR options. It delivers 4.95 MW of savings in 2031 at \$59.11/kW-year system wide. Enabling technology purchase and installation costs for enhancing customer response is a large part of VPP deployment costs.

Table 6-22 DR Program Costs and Potential – TOU Opt Out Winter

DR Option	WA	ID	System Wtd Avg Levelized \$/kW (2022-2031)	System Winter Potential MW in Year 2031
Battery Energy Storage	\$833.17	\$849.86	\$839.87	2.81
Behavioral	\$154.99	\$172.77	\$172.77	2.26
CTA-2045 WH	\$174.13		\$174.13	17.36
DLC Central AC				-
DLC Electric Vehicle Charging	\$449.91	\$452.04	\$450.67	2.85
DLC Smart Appliances	\$398.04	\$401.96	\$399.70	3.21
DLC Smart Thermostats - Cooling				-
DLC Smart Thermostats - Heating	\$76.79	\$77.74	\$77.19	9.42
DLC Water Heating		\$239.74	\$239.74	5.48
Thermal Energy Storage				-
Third Party Contracts	\$75.36	\$75.07	\$75.26	21.83
Time-of-Use Opt-in				-
Time-of-Use Opt-out	\$97.99	\$103.41	\$99.84	21.34
Variable Peak Pricing Rates	\$58.72	\$59.77	\$59.11	4.95

### Summer TOU Opt-in Scenario

Figure 6-5 and Table 6-23 show the total summer demand savings from individual DR options for selected years of the analysis. These savings represent integrated savings from all available DR options in Avista's Washington and Idaho service territories.

Key findings include:

- The highest potential option is DLC Smart Thermostats, which is expected to reach savings potential of 61 MW by 2045.



Avista Conservation Potential Assessment for 2022-2045 | Market Profiles

- The next two biggest potential options in summer include CTA-2045 WH (48.9 MW in 2045), DLC Electric Vehicle Charging (30.2 MW), and DLC Central AC (24.5 MW).
- Two Space cooling options- DLC Smart Thermostat and DLC Central AC – are expected to contribute a combined 85.5 MW by 2045.
- Total potential savings in the summer TOU Opt-in scenario are expected to increase from 11.3 MW in 2022 to 232 MW by 2045. The respective increase in the percentage of system peak increases from 0.8% in 2022 to 15.4% by 2045.

Figure 6-5 Summary of Summer Potential by Option (TOU Opt-In MW @Generator)

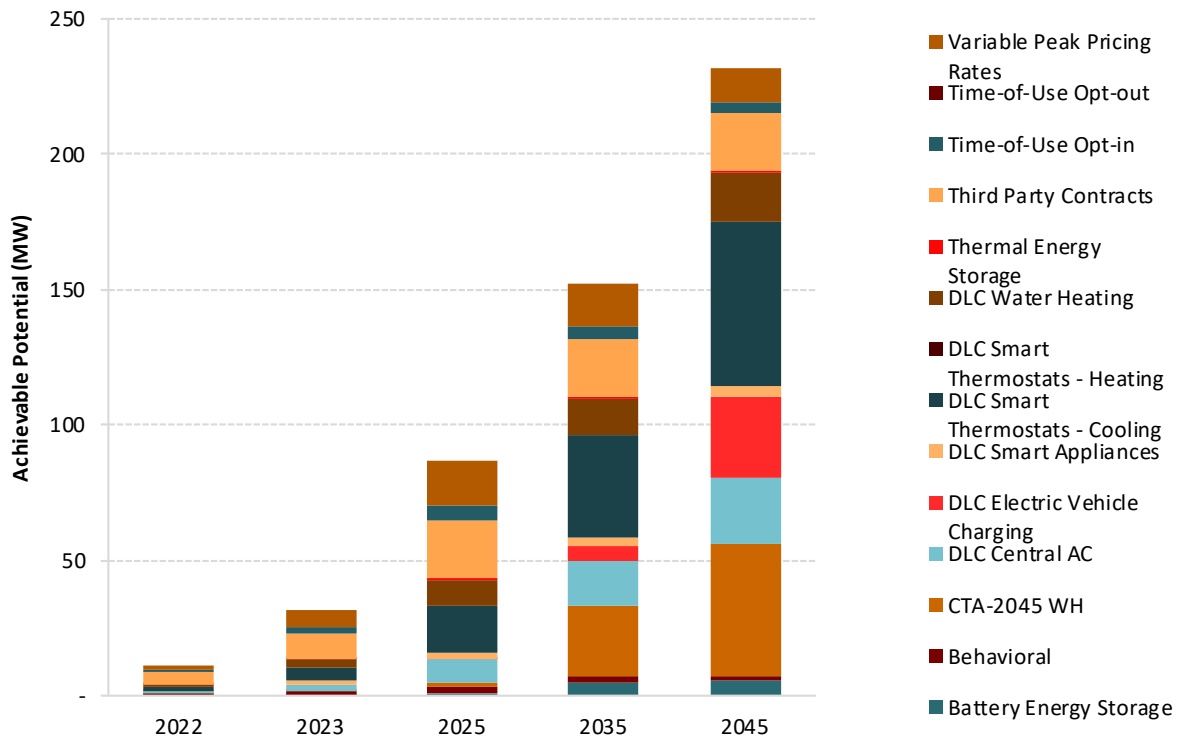

Table 6-23 Achievable DR Potential by Option TOU Opt-In (Summer MW @Generator)

	2022	2023	2025	2035	2045
<b>Total System Peak (MW)</b>	<b>1,369</b>	<b>1,376</b>	<b>1,389</b>	<b>1,446</b>	<b>1,508</b>
<b>Market Potential (MW)</b>	<b>11.3</b>	<b>31.3</b>	<b>86.8</b>	<b>151.9</b>	<b>232.0</b>
<b>Market Potential (% of baseline)</b>	<b>0.8%</b>	<b>2.3%</b>	<b>6.3%</b>	<b>10.5%</b>	<b>15.4%</b>
<b>Potential Forecast</b>	<b>1,358</b>	<b>1,344</b>	<b>1,302</b>	<b>1,294</b>	<b>1,276</b>
<b>Achievable Potential (MW)</b>					
Battery Energy Storage	0.1	0.2	0.7	5.0	5.6
Behavioral	0.6	1.3	2.6	2.1	1.7

| A-28

## Avista Conservation Potential Assessment for 2022-2045 | Market Profiles

CTA-2045 WH	0.1	0.3	1.7	26.3	48.9
DLC Central AC	0.8	2.5	8.1	16.2	24.5
DLC Electric Vehicle Charging	-	-	0.3	5.6	30.2
DLC Smart Appliances	0.3	0.9	2.7	3.3	3.7
DLC Smart Thermostats - Cooling	1.6	5.1	17.4	37.4	61.0
DLC Smart Thermostats - Heating	-	-	-	-	-
DLC Water Heating	1.0	2.9	9.1	13.7	17.8
Thermal Energy Storage	0.1	0.2	0.6	0.7	0.6
Third Party Contracts	4.5	9.8	21.4	21.3	21.4
Time-of-Use Opt-in	0.6	1.9	5.5	5.1	4.3
Time-of-Use Opt-out	-	-	-	-	-
Variable Peak Pricing Rates	1.9	6.1	16.7	15.1	12.5
<b>Achievable Potential (% of Baseline)</b>					
Battery Energy Storage	0.01%	0.02%	0.05%	0.36%	0.38%
Behavioral	0.04%	0.09%	0.18%	0.14%	0.11%
CTA-2045 WH	0.00%	0.02%	0.12%	1.82%	3.24%
DLC Central AC	0.06%	0.18%	0.58%	1.12%	1.62%
DLC Electric Vehicle Charging			0.02%	0.39%	2.00%
DLC Smart Appliances	0.02%	0.06%	0.20%	0.23%	0.25%
DLC Smart Thermostats - Cooling	0.12%	0.37%	1.25%	2.58%	4.04%
DLC Smart Thermostats - Heating					
DLC Water Heating	0.07%	0.21%	0.65%	0.95%	1.18%
Thermal Energy Storage	0.00%	0.01%	0.05%	0.05%	0.04%
Third Party Contracts	0.33%	0.71%	1.54%	1.48%	1.42%
Time-of-Use Opt-in	0.04%	0.14%	0.40%	0.35%	0.28%
Time-of-Use Opt-out					
Variable Peak Pricing Rates	0.14%	0.45%	1.20%	1.05%	0.83%

Table 6-24 and Table 6-25 show demand savings by individual DR option for the states of Washington and Idaho separately.

Table 6-24 Achievable DR Potential by Option for Washington TOU Opt-In (Summer MW @Generator)

	2022	2023	2025	2035	2045
<b>Total System Peak (MW)</b>	<b>1,369</b>	<b>1,376</b>	<b>1,389</b>	<b>1,446</b>	<b>1,508</b>

| A-29

## Avista Conservation Potential Assessment for 2022-2045 | Market Profiles

<b>Market Potential (MW)</b>	<b>8.37</b>	<b>21.28</b>	<b>55.63</b>	<b>105.72</b>	<b>164.59</b>
<b>Market Potential (% of System Peak)</b>	<b>0.6%</b>	<b>1.5%</b>	<b>4.0%</b>	<b>7.3%</b>	<b>10.9%</b>
<b>Achievable Potential (MW)</b>					
Battery Energy Storage	0.06	0.18	0.48	3.25	3.54
Behavioral	0.52	1.02	1.81	1.31	0.88
CTA-2045 WH	0.05	0.33	1.67	26.33	48.86
DLC Central AC	0.50	1.59	5.18	10.25	15.34
DLC Electric Vehicle Charging	-	-	0.20	3.65	19.47
DLC Smart Appliances	0.19	0.58	1.77	2.15	2.35
DLC Smart Thermostats - Cooling	1.02	3.25	11.12	23.68	38.26
DLC Smart Thermostats - Heating	-	-	-	-	-
DLC Water Heating	0.40	1.28	4.15	8.20	12.26
Thermal Energy Storage	0.05	0.13	0.39	0.40	0.36
Third Party Contracts	3.46	6.92	13.84	13.88	13.96
Time-of-Use Opt-in	0.49	1.41	3.76	3.22	2.41
Time-of-Use Opt-out	-	-	-	-	-
Variable Peak Pricing Rates	1.63	4.60	11.26	9.41	6.91

Table 6-25 Achievable DR Potential by Option for Idaho TOU Opt-In (Summer MW @Generator)

	2022	2023	2025	2035	2045
<b>Total System Peak (MW)</b>	<b>1,369</b>	<b>1,376</b>	<b>1,389</b>	<b>1,446</b>	<b>1,508</b>
<b>Market Potential (MW)</b>	<b>2.98</b>	<b>9.97</b>	<b>31.21</b>	<b>46.19</b>	<b>67.38</b>
<b>Market Potential (% of System Peak)</b>	<b>0.22%</b>	<b>0.72%</b>	<b>2.25%</b>	<b>3.20%</b>	<b>4.47%</b>
<b>Achievable Potential (MW)</b>					
Battery Energy Storage	0.01	0.06	0.26	1.80	2.02
Behavioral	0.08	0.31	0.83	0.80	0.78
CTA-2045 WH	-	-	-	-	-
DLC Central AC	0.28	0.89	2.90	5.92	9.11
DLC Electric Vehicle Charging	-	-	0.11	1.95	10.75
DLC Smart Appliances	0.10	0.31	0.95	1.19	1.35
DLC Smart Thermostats - Cooling	0.56	1.81	6.24	13.67	22.72
DLC Smart Thermostats - Heating	-	-	-	-	-
DLC Water Heating	0.55	1.64	4.93	5.49	5.52
Thermal Energy Storage	0.01	0.06	0.24	0.27	0.27

| A-30

## Avista Conservation Potential Assessment for 2022-2045 | Market Profiles

Third Party Contracts	1.00	2.88	7.55	7.47	7.46
Time-of-Use Opt-in	0.09	0.46	1.77	1.90	1.85
Time-of-Use Opt-out	-	-	-	-	-
Variable Peak Pricing Rates	0.30	1.55	5.42	5.73	5.57

### Cost Results

Table 6-26 presents the levelized costs per kW of equivalent generation capacity over 2022-2031 for both Washington and Idaho as well as the system weighted average levelized costs across both states. In addition, we show the 2031 savings potential from DR options for reference purposes.

Key findings include:

- DLC Smart Thermostats deliver the highest savings in 2031 (28.68 MW) at approximately \$127.27/kW-year cost. Capacity-based and energy-based payments to the third-party constitutes the major cost component for this option. All O&M and administrative costs are expected to be incurred by the representative third party contractor.
- The Variable Peak Pricing option has the lowest levelized cost among all the DR options. It delivers 16.89 MW of savings in 2031 at \$37.51/kW-year system wide. Enabling technology purchase and installation costs for enhancing customer response is a large part of CPP deployment costs.

Table 6-26 DR Program Costs and Potential – Summer TOU Opt-In

DR Option	WA	ID	System Wtd Avg Levelized \$/kW (2022-2031)	System Summer Potential MW in Year 2031
Battery Energy Storage	\$833.17	\$849.86	\$839.87	2.81
Behavioral	\$143.96	\$164.86	\$151.82	2.41
CTA-2045 WH	\$174.13		\$174.13	17.36
DLC Central AC	\$161.09	\$156.97	\$159.34	12.80
DLC Electric Vehicle Charging	\$449.91	\$452.04	\$450.67	2.85
DLC Smart Appliances	\$398.04	\$401.96	\$399.70	3.21
DLC Smart Thermostats - Cooling	\$129.24	\$124.60	\$127.27	28.68
DLC Smart Thermostats - Heating				-
DLC Water Heating		\$239.74	\$239.74	5.48
Thermal Energy Storage	\$1,000.92	\$957.45	\$983.76	0.68
Third Party Contracts	\$77.29	\$76.39	\$76.97	21.35
Time-of-Use Opt-in	\$74.13	\$94.63	\$81.21	5.71
Time-of-Use Opt-out				-
Variable Peak Pricing Rates	\$36.25	\$39.64	\$37.51	16.89

### Summer TOU Opt-out Scenario

Figure 6-6 and Table 6-27 show the total summer demand savings from individual DR options for selected years of the analysis. These savings represent integrated savings from all available DR options in Avista’s Washington and Idaho service territories.

Key findings include:

- Once again the highest savings potential resides in DLC Smart Thermostats, increasing from 1.6 MW in 2022 to 61.0 MW in 2045.
- The next two biggest potential options in Summer include CTA-2045 WH (48.9 MW by 2045), DLC Electric Vehicle Charging (30.2 MW), and DLC Central AC (24.5 MW). DLC Smart Thermostat and DLC Central AC options together contribute 85.5 MW of potential by 2045.
- In the TOU opt-out scenario, customers are placed on the Time-of-Use rate by default and will need to go through an added step to switch rates. Therefore, the majority of savings among the rates are concentrated in TOU which is expected to reach 18.3 MW by 2045.
- In the Opt-out scenario, most of the participants are likely to be on the TOU pricing rate and we see a much lower savings potential for the VPP rate (4.1 MW by 2045).
- The total potential savings in the summer TOU Opt-in scenario are expected to increase from 39.0 MW in 2022 to 225.6 MW by 2045. The respective increase in the percentage of system peak goes from 2.8% in 2022 to 15.0% by 2045.

Figure 6-6 Summary of Summer Potential – TOU Opt-Out (MW @Generator)

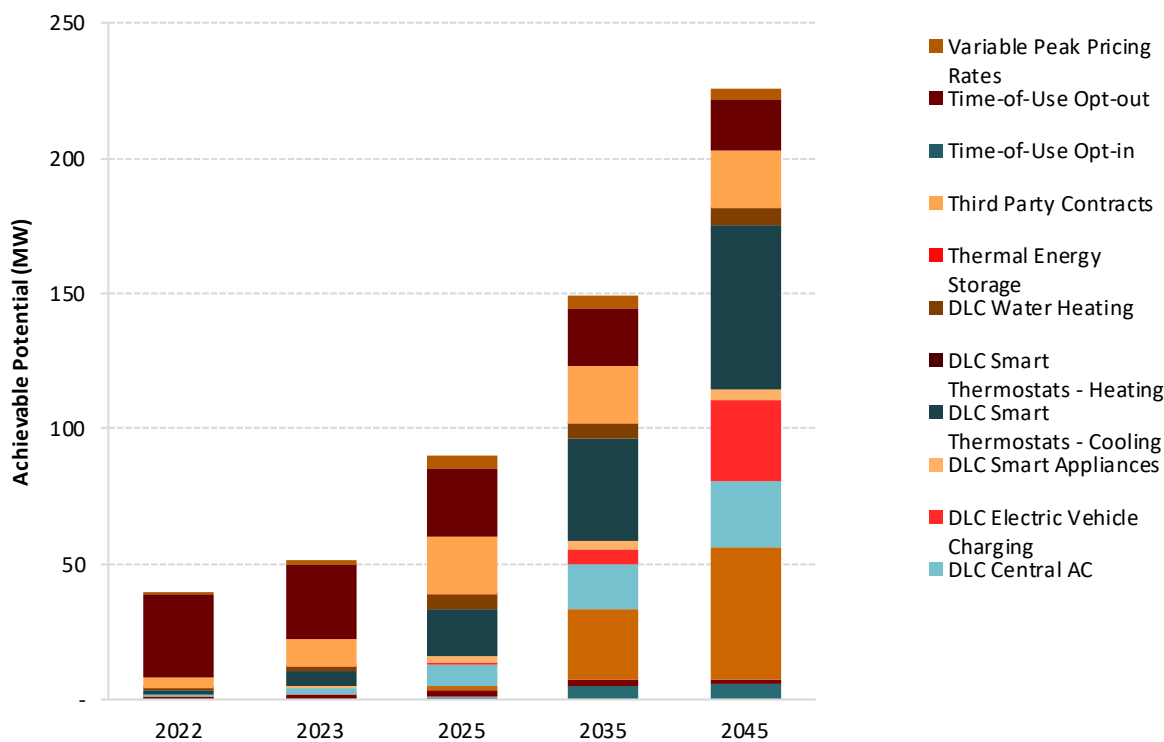

| A-32



Table 6-27 Achievable DR Potential by Option – TOU Opt-Out (Summer MW @Generator)

	2022	2023	2025	2035	2045
<b>Total System Peak (MW)</b>	<b>1,369</b>	<b>1,376</b>	<b>1,389</b>	<b>1,446</b>	<b>1,508</b>
<b>Market Potential (MW)</b>	<b>39.0</b>	<b>51.4</b>	<b>90.0</b>	<b>149.4</b>	<b>225.6</b>
<b>Market Potential (% of baseline)</b>	<b>2.8%</b>	<b>3.7%</b>	<b>6.5%</b>	<b>10.3%</b>	<b>15.0%</b>
<b>Potential Forecast</b>	<b>1,330</b>	<b>1,324</b>	<b>1,299</b>	<b>1,296</b>	<b>1,282</b>
<b>Achievable Potential (MW)</b>					
Battery Energy Storage	0.1	0.2	0.7	5.0	5.6
Behavioral	0.6	1.3	2.7	2.2	1.8
CTA-2045 WH	0.1	0.3	1.7	26.3	48.9
DLC Central AC	0.8	2.5	8.1	16.2	24.5
DLC Electric Vehicle Charging	-	-	0.3	5.6	30.2
DLC Smart Appliances	0.3	0.9	2.7	3.3	3.7
DLC Smart Thermostats - Cooling	1.6	5.1	17.4	37.4	61.0
DLC Smart Thermostats - Heating	-	-	-	-	-
DLC Water Heating	0.5	1.6	4.9	5.5	5.5
Thermal Energy Storage	0.1	0.2	0.6	0.7	0.6
Third Party Contracts	4.5	9.8	21.4	21.3	21.4
Time-of-Use Opt-in	-	-	-	-	-
Time-of-Use Opt-out	30.4	28.0	24.6	20.9	18.3
Variable Peak Pricing Rates	0.2	1.4	4.8	4.9	4.1
<b>Achievable Potential (% of Baseline)</b>					
Battery Energy Storage	0.01%	0.02%	0.05%	0.36%	0.38%
Behavioral	0.04%	0.09%	0.19%	0.15%	0.12%
CTA-2045 WH	0.00%	0.02%	0.12%	1.82%	3.24%
DLC Central AC	0.06%	0.18%	0.58%	1.12%	1.62%
DLC Electric Vehicle Charging			0.02%	0.39%	2.00%
DLC Smart Appliances	0.02%	0.06%	0.20%	0.23%	0.25%
DLC Smart Thermostats - Cooling	0.12%	0.37%	1.25%	2.58%	4.04%
DLC Smart Thermostats - Heating					
DLC Water Heating	0.04%	0.12%	0.35%	0.38%	0.37%
Thermal Energy Storage	0.00%	0.01%	0.05%	0.05%	0.04%
Third Party Contracts	0.33%	0.71%	1.54%	1.48%	1.42%
Time-of-Use Opt-in					
Time-of-Use Opt-out	2.22%	2.04%	1.77%	1.45%	1.21%
Variable Peak Pricing Rates	0.01%	0.10%	0.35%	0.34%	0.27%

Table 6-28 and Table 6-29 show demand savings by individual DR option for the states of Washington and Idaho separately.

| A-34

Table 6-28 Achievable DR Potential by Option for Washington – TOU Opt-Out (Summer MW @Generator)

	2022	2023	2025	2035	2045
<b>Total System Peak (MW)</b>	<b>1,369</b>	<b>1,376</b>	<b>1,389</b>	<b>1,446</b>	<b>1,508</b>
<b>Market Potential (MW)</b>	<b>31.19</b>	<b>35.70</b>	<b>56.62</b>	<b>101.68</b>	<b>156.75</b>
<b>Market Potential (% of System Peak)</b>	<b>2.3%</b>	<b>2.6%</b>	<b>4.1%</b>	<b>7.0%</b>	<b>10.4%</b>
<b>Achievable Potential (MW)</b>					
Battery Energy Storage	0.06	0.18	0.48	3.25	3.54
Behavioral	0.53	1.03	1.88	1.44	1.06
CTA-2045 WH	0.05	0.33	1.67	26.33	48.86
DLC Central AC	0.50	1.59	5.18	10.25	15.34
DLC Electric Vehicle Charging	-	-	0.20	3.65	19.47
DLC Smart Appliances	0.19	0.58	1.77	2.15	2.35
DLC Smart Thermostats - Cooling	1.02	3.25	11.12	23.68	38.26
DLC Smart Thermostats - Heating	-	-	-	-	-
DLC Water Heating	-	-	-	-	-
Thermal Energy Storage	0.05	0.13	0.39	0.40	0.36
Third Party Contracts	3.46	6.92	13.84	13.88	13.96
Time-of-Use Opt-in	-	-	-	-	-
Time-of-Use Opt-out	25.32	20.94	16.79	13.55	11.12
Variable Peak Pricing Rates	0.02	0.75	3.30	3.11	2.43

Table 6-29 Achievable DR Potential by Option for Idaho – TOU Opt-Out (Summer MW @Generator)

	2022	2023	2025	2035	2045
<b>Total System Peak (MW)</b>	<b>1,369</b>	<b>1,376</b>	<b>1,389</b>	<b>1,446</b>	<b>1,508</b>
<b>Market Potential (MW)</b>	<b>7.83</b>	<b>15.71</b>	<b>33.37</b>	<b>47.70</b>	<b>68.85</b>
<b>Market Potential (% of System Peak)</b>	<b>0.57%</b>	<b>1.14%</b>	<b>2.40%</b>	<b>3.30%</b>	<b>4.57%</b>
<b>Achievable Potential (MW)</b>					
Battery Energy Storage	0.01	0.06	0.26	1.80	2.02
Behavioral	0.08	0.31	0.83	0.80	0.78
CTA-2045 WH	-	-	-	-	-
DLC Central AC	0.28	0.89	2.90	5.92	9.11
DLC Electric Vehicle Charging	-	-	0.11	1.95	10.75
DLC Smart Appliances	0.10	0.31	0.95	1.19	1.35

| A-35



## Avista Conservation Potential Assessment for 2022-2045 | Market Profiles

DLC Smart Thermostats - Cooling	0.56	1.81	6.24	13.67	22.72
DLC Smart Thermostats - Heating	-	-	-	-	-
DLC Water Heating	0.55	1.64	4.93	5.49	5.52
Thermal Energy Storage	0.01	0.06	0.24	0.27	0.27
Third Party Contracts	1.00	2.88	7.55	7.47	7.46
Time-of-Use Opt-in	-	-	-	-	-
Time-of-Use Opt-out	5.07	7.08	7.82	7.39	7.18
Variable Peak Pricing Rates	0.17	0.67	1.54	1.76	1.71

### Cost Results

Table 6-30 presents the levelized costs per kW of equivalent generation capacity over 2022-2031 for both Washington and Idaho as well as the system weighted average levelized costs across both states. In addition, we show the 2031 savings potential from DR options for reference purposes.

Key findings include:

- DLC Smart Thermostats delivers the highest savings potential in 2031 (28.68 MW) at approximately \$127.27/kW-year cost. Capacity-based and energy-based payments to the third-party constitutes the major cost component for this option. All O&M and administrative costs are expected to be incurred by the representative third party contractor.
- The Variable Peak Pricing option has the lowest levelized cost among all the DR options. It delivers 5.18 MW of savings in 2031 at \$56.48/kW-year system wide. Enabling technology purchase and installation costs for enhancing customer response is a large part of CPP deployment costs.

Table 6-30 DR Program Costs and Potential – Summer TOU Opt-Out

DR Option	WA	ID	System Wtd Avg Levelized \$/kW (2022-2031)	System Summer Potential MW in Year 2031
Battery Energy Storage	\$833.17	\$849.86	\$839.87	2.81
Behavioral	\$143.96	\$164.86	\$151.02	2.41
CTA-2045 WH	\$174.13		\$174.13	17.36
DLC Central AC	\$161.09	\$156.97	\$159.34	12.80
DLC Electric Vehicle Charging	\$449.91	\$452.04	\$450.67	2.85
DLC Smart Appliances	\$398.04	\$401.96	\$399.70	3.21
DLC Smart Thermostats - Cooling	\$129.24	\$124.60	\$127.27	28.68
DLC Smart Thermostats - Heating				-
DLC Water Heating		\$239.74	\$239.74	5.48
Thermal Energy Storage	\$1,000.92	\$957.45	\$983.76	0.68
Third Party Contracts	\$77.29	\$76.39	\$76.97	21.35

| A-36

Time-of-Use Opt-in				
Time-of-Use Opt-out	\$93.94	\$100.94	\$96.35	22.10
Variable Peak Pricing Rates	\$55.64	\$57.91	\$56.48	5.18

## Stand-alone Potential Results

The above results assume that the programs are offered on an integrated basis where participation across similar options do not overlap. However, it is also important to see the potential by option where each program is unaffected by participation in other options. This way, Avista can gauge the impact from implementing an individual program. For this scenario we do not combine the potential savings and only show individual potential contributions by program for each scenario.

### Winter Results

Figure 6-7 and Table 6-31 show the winter demand savings from individual DR options for selected years of the analysis. These savings represent stand-alone savings from all available DR options in Avista's Washington and Idaho service territories.

Key findings include:

- The largest savings potential resides in CTA-2045 WH, contributing 0.1 MW of potential in 2022 and increasing to 48.9 MW by 2045.
- The next biggest option is DLC Electric Vehicle Charging, at 30.2 MW of potential by 2045.
- When each TOU option is examined as an individual program, the Time-of-Use Opt-out option has a much larger potential savings than if participants could opt-in to the rate. The TOU Opt-out option is expected to reach 29.9 MW by 2045 in the stand-alone case.
- Since the different rate options do not influence other rates in the stand-alone scenario, each rate has a larger potential savings than in the Opt-out/Opt-in scenarios.

Figure 6-8 Summary of Potential Analysis for Avista (Winter Peak MW @Generator)

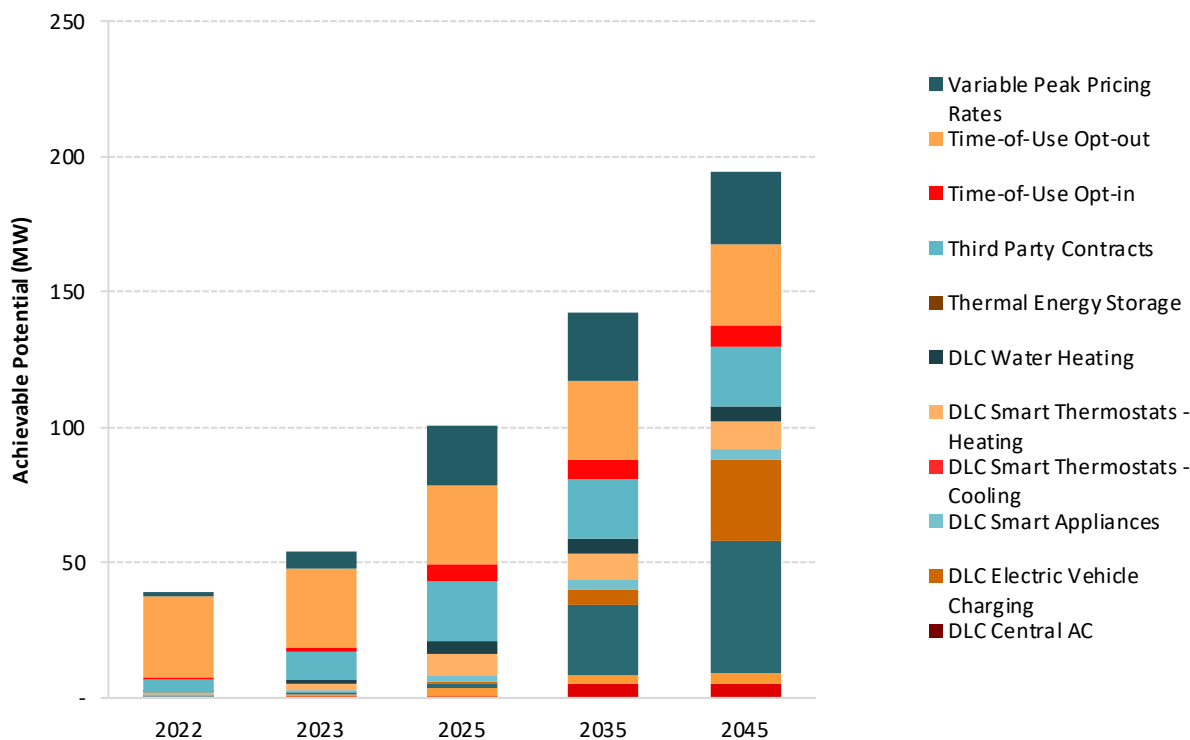

Table 6-32 Achievable DR Potential by Option (Winter MW @Generator)

	2022	2023	2025	2035	2045
<b>Total System Peak (MW)</b>	<b>1,331</b>	<b>1,337</b>	<b>1,349</b>	<b>1,403</b>	<b>1,444</b>
<b>Market Potential (MW)</b>	<b>39.5</b>	<b>54.2</b>	<b>100.2</b>	<b>142.6</b>	<b>194.5</b>
<b>Market Potential (% of baseline)</b>	<b>3.0%</b>	<b>4.1%</b>	<b>7.4%</b>	<b>10.2%</b>	<b>13.5%</b>
<b>Potential Forecast</b>	<b>1,291</b>	<b>1,282</b>	<b>1,249</b>	<b>1,261</b>	<b>1,250</b>
<b>Achievable Potential (MW)</b>					
Battery Energy Storage	0.1	0.2	0.7	5.0	5.6
Behavioral	0.6	1.3	3.0	3.1	3.3
CTA-2045 WH	0.1	0.3	1.7	26.3	48.9
DLC Central AC	-	-	-	-	-
DLC Electric Vehicle Charging	-	-	0.3	5.6	30.2
DLC Smart Appliances	0.3	0.9	2.7	3.3	3.7
DLC Smart Thermostats - Cooling	-	-	-	-	-
DLC Smart Thermostats - Heating	0.9	2.6	8.0	9.8	10.9
DLC Water Heating	0.5	1.6	4.9	5.5	5.5
Thermal Energy Storage	-	-	-	-	-

| A-38

## Avista Conservation Potential Assessment for 2022-2045 | Market Profiles

Third Party Contracts	4.6	10.0	21.9	21.8	21.9
Time-of-Use Opt-in	0.6	1.9	6.4	7.5	7.8
Time-of-Use Opt-out	30.1	28.8	28.5	28.9	29.9
Variable Peak Pricing Rates	1.9	6.5	22.0	25.7	26.9
<b>Achievable Potential (% of Baseline)</b>					
Battery Energy Storage	0.01%	0.02%	0.05%	0.36%	0.39%
Behavioral	0.04%	0.10%	0.22%	0.22%	0.23%
CTA-2045 WH	0.00%	0.02%	0.12%	1.88%	3.38%
DLC Central AC					
DLC Electric Vehicle Charging			0.02%	0.40%	2.09%
DLC Smart Appliances	0.02%	0.07%	0.20%	0.24%	0.26%
DLC Smart Thermostats - Cooling					
DLC Smart Thermostats - Heating	0.06%	0.19%	0.59%	0.70%	0.75%
DLC Water Heating	0.04%	0.12%	0.37%	0.39%	0.38%
Thermal Energy Storage					
Third Party Contracts	0.34%	0.75%	1.62%	1.56%	1.52%
Time-of-Use Opt-in	0.04%	0.14%	0.48%	0.53%	0.54%
Time-of-Use Opt-out	2.26%	2.16%	2.11%	2.06%	2.07%
Variable Peak Pricing Rates	0.14%	0.49%	1.63%	1.83%	1.86%

Table 6-33 and Table 6-34 show demand savings by individual DR option for the states of Washington and Idaho separately.

Table 6-33 Achievable DR Potential by Option for Washington (Winter MW @Generator)

	2022	2023	2025	2035	2045
<b>Total System Peak (MW)</b>	<b>1,331</b>	<b>1,337</b>	<b>1,349</b>	<b>1,403</b>	<b>1,463</b>
<b>Market Potential (MW)</b>	<b>31.90</b>	<b>38.50</b>	<b>63.59</b>	<b>99.07</b>	<b>140.00</b>
<b>Market Potential (% of System Peak)</b>	<b>2.4%</b>	<b>2.9%</b>	<b>4.7%</b>	<b>7.1%</b>	<b>9.6%</b>
<b>Achievable Potential (MW)</b>					
Battery Energy Storage	0.06	0.18	0.48	3.25	3.54
Behavioral	0.49	0.99	2.01	2.10	2.18
CTA-2045 WH	0.05	0.33	1.67	26.33	48.86
DLC Central AC	-	-	-	-	-
DLC Electric Vehicle Charging	-	-	0.20	3.65	19.47
DLC Smart Appliances	0.19	0.58	1.77	2.15	2.35
DLC Smart Thermostats - Cooling	-	-	-	-	-
DLC Smart Thermostats - Heating	0.57	1.71	5.23	6.37	6.97

| A-39

## Avista Conservation Potential Assessment for 2022-2045 | Market Profiles

DLC Water Heating	-	-	-	-	-
Thermal Energy Storage	-	-	-	-	-
Third Party Contracts	3.55	7.10	4.20	14.23	14.31
Time-of-Use Opt-in	0.47	1.43	4.32	4.95	5.11
Time-of-Use Opt-out	24.92	21.36	19.07	19.18	19.71
Variable Peak Pricing Rates	1.60	4.83	14.65	16.88	17.49

Table 6-34 Achievable DR Potential by Option for Idaho (Winter MW @Generator)

	2022	2023	2025	2035	2045
<b>Total System Peak (MW)</b>	<b>1,331</b>	<b>1,337</b>	<b>1,349</b>	<b>1,403</b>	<b>1,463</b>
<b>Market Potential (MW)</b>	<b>7.59</b>	<b>15.74</b>	<b>36.63</b>	<b>43.52</b>	<b>54.53</b>
<b>Market Potential (% of System Peak)</b>	<b>0.57%</b>	<b>1.18%</b>	<b>2.71%</b>	<b>3.10%</b>	<b>3.73%</b>
<b>Achievable Potential (MW)</b>					
Battery Energy Storage	0.01	0.06	0.26	1.80	2.02
Behavioral	0.08	0.31	0.97	1.05	1.14
CTA-2045 WH	-	-	-	-	-
DLC Central AC	-	-	-	-	-
DLC Electric Vehicle Charging	-	-	0.11	1.95	10.75
DLC Smart Appliances	0.10	0.31	0.95	1.19	1.35
DLC Smart Thermostats - Cooling	-	-	-	-	-
DLC Smart Thermostats - Heating	0.29	0.89	2.74	3.44	3.89
DLC Water Heating	0.55	1.64	4.93	5.49	5.52
Thermal Energy Storage	-	-	-	-	-
Third Party Contracts	1.02	2.93	7.69	7.60	7.58
Time-of-Use Opt-in	0.09	0.48	2.12	2.50	2.66
Time-of-Use Opt-out	5.15	7.45	9.46	9.70	10.22
Variable Peak Pricing Rates	0.30	1.66	7.40	8.79	9.41

**Summer Results**

Figure 6-9 and Table 6-36 show the summer demand savings from individual DR options for selected years of the analysis. These savings represent the individual stand-alone savings from all available DR options in Avista's Washington and Idaho service territories.

Key findings include:

- The largest potential option is DLC Smart thermostats, at 61.0 MW by 2045.

| A-40

- The next two biggest potential options in summer include CTA-2045 WH and TOU Opt-out, each of which are projected to contribute over 30 MW by 2045. DLC Central AC and DLC Electric Vehicle Charging also have high savings potential by 2045.
- When each TOU option is examined as an individual program, the Time-of-Use Opt-out option has a much larger potential savings than if participants could opt-in to the rate. The TOU Opt-out option makes up the second-largest savings potential in the stand-alone case and is expected to reach 31.1 MW by 2045.
- Since the different rate options do not influence other rates in the stand-alone scenario, each rate has a larger potential savings than in the Opt-out/Opt-in scenarios.

Figure 6-9 Summary of Summer Potential by Option (MW @Generator)

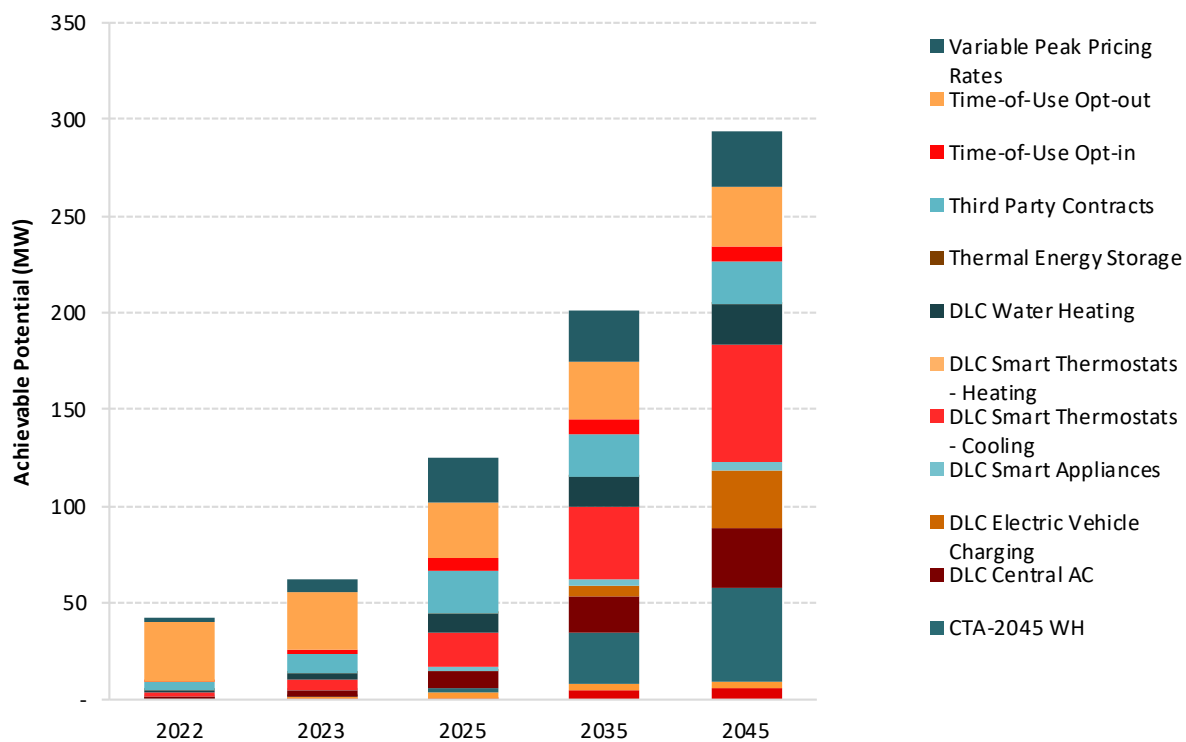

Table 6-35 Achievable DR Potential by Option (Summer MW @Generator)

	2022	2023	2025	2035	2045
<b>Total System Peak (MW)</b>	<b>1,369</b>	<b>1,376</b>	<b>1,389</b>	<b>1,446</b>	<b>1,508</b>
<b>Market Potential (MW)</b>	<b>42.6</b>	<b>62.1</b>	<b>125.5</b>	<b>201.5</b>	<b>293.8</b>
<b>Market Potential (% of baseline)</b>	<b>3.1%</b>	<b>4.5%</b>	<b>9.0%</b>	<b>13.9%</b>	<b>19.5%</b>
<b>Potential Forecast</b>	<b>1,327</b>	<b>1,314</b>	<b>1,264</b>	<b>1,244</b>	<b>1,214</b>
<b>Achievable Potential (MW)</b>					
Battery Energy Storage	0.1	0.2	0.7	5.0	5.6
Behavioral	0.6	1.4	3.2	3.4	3.5
CTA-2045 WH	0.1	0.3	1.7	26.3	48.9

| A-41

## Avista Conservation Potential Assessment for 2022-2045 | Market Profiles

DLC Central AC	0.8	2.5	8.7	18.7	30.5
DLC Electric Vehicle Charging	-	-	0.3	5.6	30.2
DLC Smart Appliances	0.3	0.9	2.7	3.3	3.7
DLC Smart Thermostats - Cooling	1.6	5.1	17.4	37.4	61.0
DLC Smart Thermostats - Heating	-	-	-	-	-
DLC Water Heating	1.0	2.9	9.4	15.0	20.8
Thermal Energy Storage	0.1	0.2	0.7	0.8	0.8
Third Party Contracts	4.5	9.8	21.4	21.3	21.4
Time-of-Use Opt-in	0.6	2.0	6.7	7.8	8.1
Time-of-Use Opt-out	31.2	29.9	29.6	30.0	31.1
Variable Peak Pricing Rates	2.0	6.8	23.1	26.9	28.2
<b>Achievable Potential (% of Baseline)</b>					
Battery Energy Storage	0.01%	0.02%	0.05%	0.36%	0.39%
Behavioral	0.04%	0.10%	0.22%	0.22%	0.23%
CTA-2045 WH	0.00%	0.02%	0.12%	1.82%	3.24%
DLC Central AC	0.06%	0.18%	0.62%	1.29%	2.02%
DLC Electric Vehicle Charging			0.02%	0.39%	2.00%
DLC Smart Appliances	0.02%	0.06%	0.20%	0.23%	0.25%
DLC Smart Thermostats - Cooling	0.12%	0.37%	1.25%	2.58%	4.04%
DLC Smart Thermostats - Heating					
DLC Water Heating	0.07%	0.21%	0.68%	1.04%	1.38%
Thermal Energy Storage	0.00%	0.01%	0.05%	0.05%	0.06%
Third Party Contracts	0.33%	0.71%	1.54%	1.48%	1.42%
Time-of-Use Opt-in	0.04%	0.15%	0.49%	0.54%	0.54%
Time-of-Use Opt-out	2.28%	2.17%	2.13%	2.07%	2.06%
Variable Peak Pricing Rates	0.15%	0.49%	1.66%	1.86%	1.87%

Table 6-37 and Table 6-38 show summer demand savings by individual DR option for the states of Washington and Idaho separately. The programs with the largest potential savings are CTA-2045 WH, DLC Smart Thermostat, and TOU rates.

Table 6-36 Achievable DR Potential by Option for Washington (Summer MW @Generator)

	2022	2023	2025	2035	2045
<b>Total System Peak (MW)</b>	<b>1,369</b>	<b>1,376</b>	<b>1,389</b>	<b>1,446</b>	<b>1,508</b>
<b>Market Potential (MW)</b>	<b>34.41</b>	<b>44.24</b>	<b>81.54</b>	<b>140.01</b>	<b>208.12</b>
<b>Market Potential (% of System Peak)</b>	<b>2.5%</b>	<b>3.2%</b>	<b>5.9%</b>	<b>9.7%</b>	<b>13.8%</b>
<b>Achievable Potential (MW)</b>					
Battery Energy Storage	0.06	0.18	0.48	3.25	3.54
Behavioral	0.53	1.07	2.17	2.26	2.35

| A-42

## Avista Conservation Potential Assessment for 2022-2045 | Market Profiles

CTA-2045 WH	0.05	0.33	1.67	26.33	48.86
DLC Central AC	0.51	1.63	5.56	11.84	19.13
DLC Electric Vehicle Charging	-	-	0.20	3.65	19.47
DLC Smart Appliances	0.19	0.58	1.77	2.15	2.35
DLC Smart Thermostats - Cooling	1.02	3.25	11.12	23.68	38.26
DLC Smart Thermostats - Heating	-	-	-	-	-
DLC Water Heating	0.41	1.30	4.45	9.47	15.28
Thermal Energy Storage	0.05	0.14	0.41	0.48	0.50
Third Party Contracts	3.46	6.92	13.84	13.88	13.96
Time-of-Use Opt-in	0.50	1.50	4.55	5.22	5.39
Time-of-Use Opt-out	25.96	22.26	19.87	20.00	20.57
Variable Peak Pricing Rates	1.69	5.09	15.45	17.80	18.46

Table 6-37 Achievable DR Potential by Option for Idaho (Summer MW @Generator)

	2022	2023	2025	2035	2045
<b>Total System Peak (MW)</b>	<b>1,369</b>	<b>1,376</b>	<b>1,389</b>	<b>1,446</b>	<b>1,508</b>
<b>Market Potential (MW)</b>	<b>8.21</b>	<b>17.81</b>	<b>43.96</b>	<b>61.44</b>	<b>85.68</b>
<b>Market Potential (% of System Peak)</b>	<b>0.60%</b>	<b>1.29%</b>	<b>3.17%</b>	<b>4.25%</b>	<b>5.68%</b>
<b>Achievable Potential (MW)</b>					
Battery Energy Storage	0.01	0.06	0.26	1.80	2.02
Behavioral	0.08	0.33	1.02	1.10	1.20
CTA-2045 WH	-	-	-	-	-
DLC Central AC	0.28	0.91	3.12	6.84	11.36
DLC Electric Vehicle Charging	-	-	0.11	1.95	10.75
DLC Smart Appliances	0.10	0.31	0.95	1.19	1.35
DLC Smart Thermostats - Cooling	0.56	1.81	6.24	13.67	22.72
DLC Smart Thermostats - Heating	-	-	-	-	-
DLC Water Heating	0.55	1.64	4.93	5.49	5.52
Thermal Energy Storage	0.01	0.06	0.26	0.31	0.33
Third Party Contracts	1.00	2.88	7.55	7.47	7.46
Time-of-Use Opt-in	0.09	0.50	2.19	2.59	2.75
Time-of-Use Opt-out	5.22	7.61	9.71	9.97	10.51
Variable Peak Pricing Rates	0.31	1.71	7.63	9.07	9.72

| A-43



## Ancillary Services

Traditionally, ancillary services have been defined broadly as an option for Avista to use that stem from other DR programs at their disposal. This year, AEG wanted to provide Avista with feasible ancillary programs that are subsets of several programs defined above. AEG chose seven parent programs off of which to base ancillary options: Smart Thermostats Cooling, Smart Thermostats Heating, DLC Water Heating, CTA-2045 Water Heating, Electric Vehicle Charging, Third Party Contracts, and Battery Energy Storage. The results in this section are considered to be separate from the achievable potential discussed earlier in this chapter.

The ancillary programs were replicas of their parent programs with several exceptions. For participation, AEG assumed the same participation as the parent program for Battery Energy Storage, Electric Vehicle Charging, DLC Water Heating, and CTA-2045 Water Heating projecting that the same customers would also be eligible for an ancillary program. Participation in Third Party Contracts were based on the saturations of EMS systems for commercial customers in the PacifiCorp territory and the participation in Smart Thermostats Programs were assumed to be half of their respective parent programs.

For Impact assumptions, AEG assumed the same impacts for ancillary Battery Energy Storage, DLC Water Heating, and CTA-2045 Water Heating programs as their parent programs. For Ancillary Third Party Contracts, AEG assumed a 75% realization rate of the parent impact since there is more of a change a C&I customer will contribute less on an ancillary option. For ancillary Smart Thermostat and Electric Vehicle Charging options AEG assumed half the impacts of their respective parent programs.

Since the ancillary programs are subsets of the main programs, AEG assumed the ancillary programs would take half of the administrative and development costs of the parent programs to implement. In addition, to avoid double counting, equipment costs and O&M costs are assumed to be zero for the ancillary programs. The ancillary programs assume the same annual marketing and recruitment costs and incentive costs as the parent programs.

## Winter Results

Table 6-40 and Figure 6-11 show the winter demand savings from individual DR options for selected years of the analysis. These savings represent stand-alone savings from all available DR options in Avista's Washington and Idaho service territories.

Table 6-38 Achievable DR Potential by Ancillary Option (Winter MW @Generator)

	2022	2023	2025	2035	2045
<b>Baseline Forecast (MW)</b>	<b>1,331</b>	<b>1,337</b>	<b>1,349</b>	<b>1,403</b>	<b>1,444</b>
<b>Ancillary Potential (MW)</b>	<b>2</b>	<b>4</b>	<b>13</b>	<b>45</b>	<b>81</b>
Ancillary Battery Storage	0.1	0.2	0.7	5.0	5.6
Ancillary Cooling	-	-	-	-	-
Ancillary EV	-	-	0.2	2.8	15.1
Ancillary Heating	0.2	0.7	2.0	2.5	2.7
Ancillary Third Party	0.7	1.5	3.3	3.3	3.3
Ancillary CTA-2045 WH	0.1	0.3	1.7	26.3	48.9
Ancillary DLC WH	0.5	1.6	4.9	5.5	5.5

| A-44

Figure 6-10 Achievable DR Potential by Ancillary Option (Winter MW @Generator)

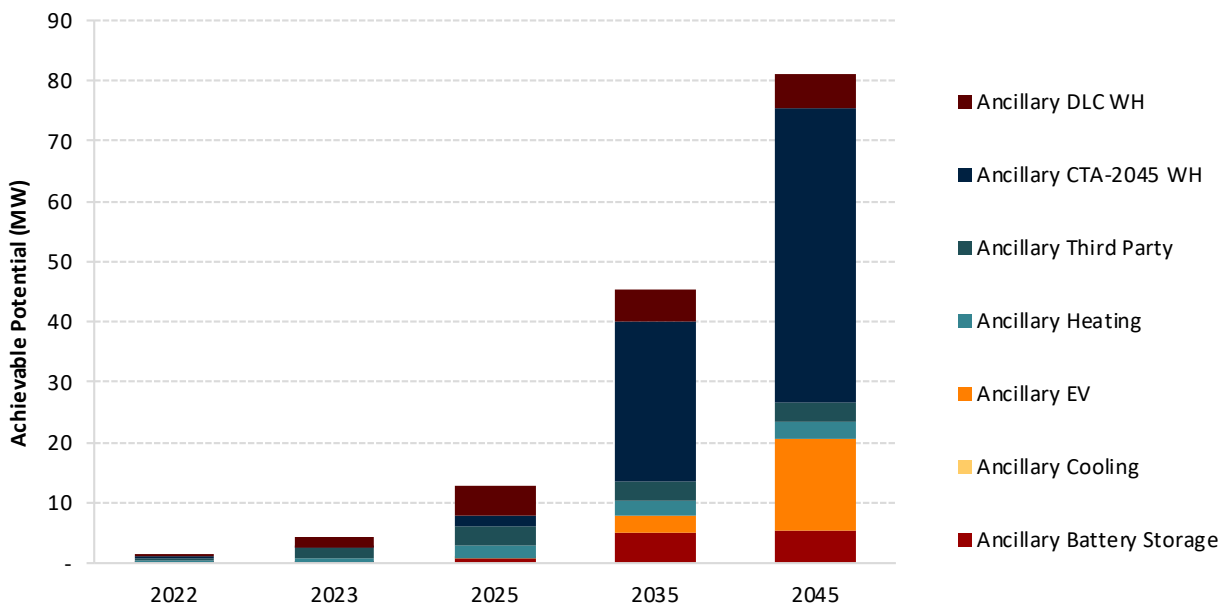

For winter ancillary potential, the Ancillary CTA-2045 Water Heater Program is expected to have the highest potential by 2031 (13.91 MW), reaching 48.9 MW by 2045. This is due to the fact that full participation and impacts are assumed for this ancillary program. Ancillary EV has the second most potential and is expected to reach 1.43 MW by 2031 and 15.1 MW by 2045.

Table 6-39 Winter Levelized Costs for Ancillary Options

Class	DR Option	WA	ID	System Wtd Avg Levelized \$/kW (2022-2031)	System Winter Potential MW in Year 2031
Residential	Ancillary Battery Storage	\$91.29	\$94.85	\$92.52	2.41
	Ancillary Cooling				
	Ancillary EV	\$275.23	\$275.76	\$275.41	1.43
	Ancillary Heating	\$75.10	\$75.98	\$75.41	2.29
	Ancillary Third Party				
	Ancillary CTA-2045 WH	\$101.25		\$101.25	13.91
	Ancillary DLC WH		\$87.27	\$87.27	4.73
	Ancillary Battery Storage	\$89.74	\$94.46	\$91.63	0.41
C&I	Ancillary Cooling				
	Ancillary EV				
	Ancillary Heating	\$198.09	\$197.74	\$197.94	0.07
	Ancillary Third Party	\$37.68	\$37.54	\$37.63	3.27
	Ancillary CTA-2045 WH	\$43.51		\$43.51	3.46
	Ancillary DLC WH		\$42.99	\$42.99	0.76

The levelized costs are calculated using a ten year horizon between 2022 and 2031. *Table 6-39* splits these out by residential and C&I sectors. On average, Ancillary Third Party Contracts are the cheapest option at a cost of \$37.63 per kW while Ancillary Electric Vehicle Charging is the most expensive option at a cost of \$275.41 per kW.

Table 6-40 Achievable DR Potential by Ancillary Option (Summer MW @Generator)

	2022	2023	2025	2035	2045
<b>Baseline Forecast (MW)</b>	<b>1,369</b>	<b>1,376</b>	<b>1,389</b>	<b>1,446</b>	<b>1,508</b>
<b>Ancillary Potential (MW)</b>	<b>2</b>	<b>5</b>	<b>15</b>	<b>52</b>	<b>94</b>
Ancillary Battery Storage	0.1	0.2	0.7	5.0	5.6
Ancillary Cooling	0.4	1.3	4.3	9.3	15.2
Ancillary EV	-	-	0.2	2.8	15.1
Ancillary Heating	-	-	-	-	-
Ancillary Third Party	0.7	1.5	3.2	3.2	3.2
Ancillary CTA-2045 WH	0.1	0.3	1.7	26.3	48.9
Ancillary DLC WH	0.5	1.6	4.9	5.5	5.5

Avista Conservation Potential Assessment for 2022-2045 | Market Profiles

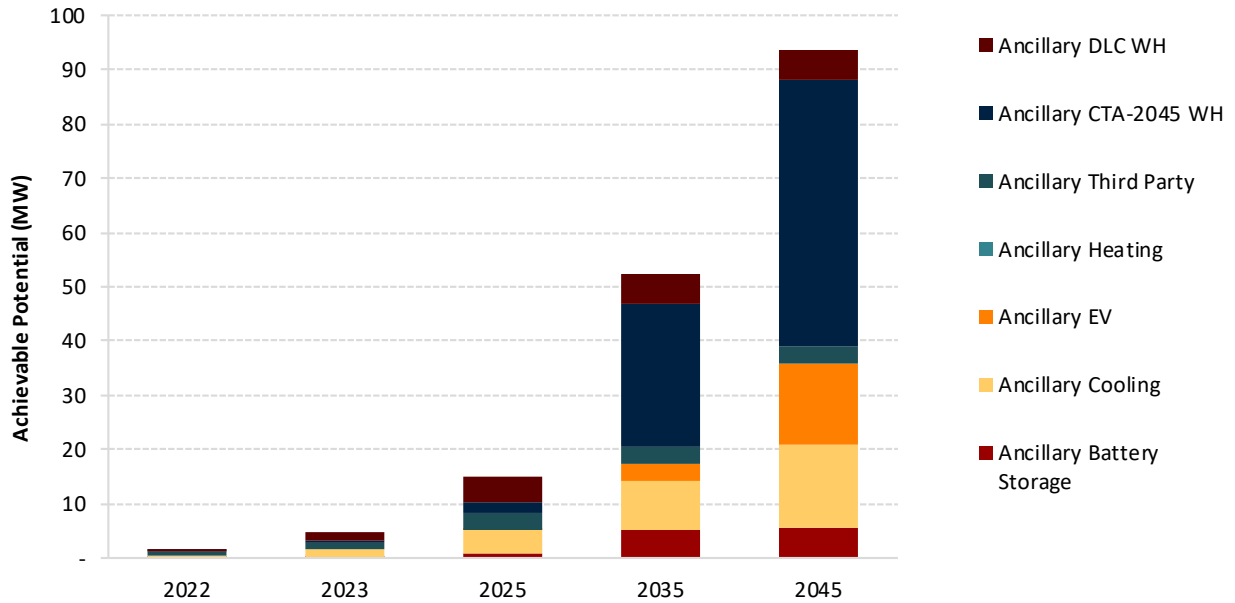

Similar to winter, the Ancillary CTA-2045 Water Heater Program is again expected to have the highest potential by 2045 (48.9 MW) during the summer season. Ancillary Smart Thermostats-Cooling is projected to have the second highest potential at 15.2 MW while Ancillary EV is projected to have the third most potential and is expected to reach 15.1 MW by 2045 (same as winter).

The levelized costs are calculated using a ten year horizon between 2022 and 2031. *Table 6-41* splits these out by residential and C&I sectors. On average, Ancillary Third Party Contracts are the cheapest option at a cost of \$38.49 per kW while Ancillary Electric Vehicle Charging is the most expensive option at a cost of \$275.42 per kW.

Table 6-41 Summer Levelized Costs for Ancillary Options

Class	DR Option	WA	ID	System Wtd Avg Levelized \$/kW (2022-2031)	System Winter Potential MW in Year 2031
Residential	Ancillary Battery Storage	\$91.29	\$94.85	\$92.56	2.41
	Ancillary Cooling	\$126.38	\$127.03	\$126.61	5.59
	Ancillary EV	\$275.23	\$275.76	\$275.42	1.43
	Ancillary Heating				
	Ancillary Third Party				
	Ancillary CTA-2045 WH	\$101.25		\$101.25	13.91
	Ancillary DLC WH			\$87.27	\$87.27
C&I	Ancillary Battery Storage	\$89.74	\$94.46	\$91.63	0.41
	Ancillary Cooling	\$59.69	\$59.76	\$59.72	1.58
	Ancillary EV				
	Ancillary Heating				

| A-47

## Avista Conservation Potential Assessment for 2022-2045 | Market Profiles

---

Ancillary Third Party	\$38.64	\$38.19	\$38.49	3.20
Ancillary CTA-2045 WH	\$43.51		\$43.51	3.46
Ancillary DLC WH		\$42.99	\$42.99	0.76

---

## A

## MARKET PROFILES

This appendix presents the market profiles for each sector and segment for Washington and Idaho, in the embedded spreadsheet.



Avista 2020 Electric  
CPA Market Profile T



## B

## MARKET ADOPTION (RAMP) RATES

This appendix presents the Power Council's 2021 Power Plan ramp rates we applied to technical potential to estimate Technical Achievable Potential.

Table B-1 Measure Ramp Rates Used in CPA

Ramp Rate	2022	2023	2024	2025	2026	2027	2028	2029	2030	2031	2032	2033	2034	2035	2036	2037	2038	2039	2040	2041
<b>LO12Med</b>	11%	22%	33%	44%	55%	65%	72%	79%	84%	88%	91%	94%	96%	97%	99%	100%	100%	100%	100%	100%
<b>LO5Med</b>	4%	10%	16%	24%	32%	42%	53%	64%	75%	84%	91%	96%	99%	100%	100%	100%	100%	100%	100%	100%
<b>LO1Slow</b>	1%	1%	2%	3%	5%	9%	13%	19%	26%	34%	43%	53%	63%	72%	81%	87%	92%	96%	98%	100%
<b>LO50Fast</b>	45%	66%	80%	89%	95%	98%	99%	100%	100%	100%	100%	100%	100%	100%	100%	100%	100%	100%	100%	100%
<b>LO20Fast</b>	22%	38%	48%	57%	64%	70%	76%	80%	84%	88%	90%	92%	94%	95%	96%	97%	98%	98%	99%	100%
<b>LOEven20</b>	5%	10%	15%	20%	25%	30%	35%	40%	45%	50%	55%	60%	65%	70%	75%	80%	85%	90%	95%	100%
<b>LO3Slow</b>	1%	1%	3%	6%	11%	18%	26%	36%	46%	57%	67%	76%	83%	88%	92%	95%	97%	98%	99%	100%
<b>LO80Fast</b>	76%	83%	88%	92%	95%	97%	98%	99%	99%	100%	100%	100%	100%	100%	100%	100%	100%	100%	100%	100%
<b>Retro12Med</b>	11%	11%	11%	11%	11%	10%	8%	6%	5%	4%	3%	3%	2%	2%	1%	1%	0%	0%	0%	0%
<b>Retro5Med</b>	4%	5%	6%	8%	9%	10%	11%	11%	11%	9%	7%	5%	3%	1%	1%	0%	0%	0%	0%	0%
<b>Retro1Slow</b>	0%	1%	1%	1%	2%	3%	4%	6%	7%	8%	9%	10%	10%	9%	8%	7%	5%	4%	2%	2%
<b>Retro50Fast</b>	45%	21%	14%	9%	6%	3%	1%	1%	0%	0%	0%	0%	0%	0%	0%	0%	0%	0%	0%	0%
<b>Retro20Fast</b>	22%	16%	11%	8%	7%	6%	5%	5%	4%	3%	3%	2%	2%	1%	1%	1%	1%	1%	1%	0%
<b>RetroEven20</b>	5%	5%	5%	5%	5%	5%	5%	5%	5%	5%	5%	5%	5%	5%	5%	5%	5%	5%	5%	5%
<b>Retro3Slow</b>	1%	1%	2%	3%	5%	7%	8%	10%	11%	11%	10%	9%	7%	6%	4%	3%	2%	1%	1%	1%





# C

## MEASURE DATA

Measure level assumptions and data are available in the "Avista 2019 DSM Potential Study Measure Assumptions" workbook provided to Avista alongside this file.

| C-1

| C-1



| C-1

| C-1

---

Applied Energy Group • [www.appliedenergygroup.com](http://www.appliedenergygroup.com)

**Applied Energy Group, Inc.**  
500 Ygnacio Valley Rd, Suite 250  
Walnut Creek, CA 94596

P: 510.982.3525

# 2021 Electric Integrated Resource Plan

## Appendix F – Avoided Cost Calculations



**Estimated Avoided Costs**  
**Energy Only Value Assuming Flat Delivery All Hours in a Year -- Example Rates For Large QF Resources, Not Applicable to Small QF**  
**Hourly Values (\$/MWh)**

HLH	2021	2022	2023	2024	2025	2026	2027	2028	2029	2030	2031	2032	2033	2034	2035	2036	2037	2038	2039	2040	2041	2042	2043	2044	2045
Jan	24.43	25.73	22.61	21.92	23.26	27.38	31.85	32.82	35.03	35.93	36.79	37.33	38.90	40.33	42.17	43.74	45.51	47.52	49.40	50.47	53.79	56.36	59.95	65.16	66.09
Feb	20.20	20.90	18.70	17.12	20.23	22.29	25.99	26.54	28.35	28.52	29.10	30.06	32.68	33.34	34.53	35.22	38.44	37.46	38.16	39.52	43.07	40.47	42.79	47.74	52.28
Mar	17.29	18.05	16.87	17.88	17.25	17.73	21.75	21.95	25.35	25.62	33.38	37.05	38.44	47.12	48.31	54.59	47.35	42.79	39.77	34.87	27.99	26.65	26.00	23.65	24.37
Apr	11.27	11.54	12.50	15.27	17.03	18.98	17.25	13.17	13.44	14.76	16.03	20.64	18.57	17.23	21.42	16.94	13.66	12.87	6.94	1.38	1.28	(4.59)	(4.64)	(4.49)	(5.35)
May	4.19	4.27	5.38	3.73	1.90	1.88	(3.04)	(5.79)	(4.92)	(6.97)	(8.35)	(6.48)	(8.48)	(8.98)	(7.66)	(8.96)	(9.83)	(9.12)	(10.93)	(11.68)	(11.79)	(8.60)	(11.15)	(6.29)	(13.24)
Jun	12.90	13.08	13.26	15.20	11.82	11.44	10.37	4.05	3.50	(1.19)	(5.18)	(4.32)	(4.59)	(4.34)	(4.61)	(6.23)	(7.00)	(7.06)	(7.14)	(7.79)	(8.86)	(10.65)	(11.41)	(11.76)	4.07
Jul	17.63	18.71	19.54	20.21	21.31	22.63	27.02	25.00	26.30	27.62	24.41	27.22	24.31	20.34	16.87	15.73	15.22	16.06	13.36	12.00	3.21	1.74	3.27	2.51	7.21
Aug	23.01	24.46	24.94	25.02	28.64	28.72	33.69	31.21	32.73	34.26	34.16	34.97	34.84	35.77	36.12	41.79	39.30	39.63	37.60	40.65	33.33	32.47	33.60	34.88	45.16
Sep	21.49	22.18	24.48	22.95	25.95	27.71	31.76	29.25	30.17	30.38	30.56	32.42	33.92	33.38	33.39	35.20	35.83	38.12	43.03	43.18	39.70	37.69	42.43	42.73	48.04
Oct	19.43	20.01	21.18	20.37	23.53	23.91	27.88	24.91	27.07	28.52	27.00	29.20	31.42	32.22	33.31	34.78	37.47	38.73	48.08	44.96	55.39	62.05	56.09	46.98	47.34
Nov	18.66	19.83	18.54	19.75	21.37	25.40	27.33	27.27	30.10	29.68	31.47	31.25	34.24	37.06	41.58	39.99	44.82	48.13	49.28	51.38	59.59	53.91	55.49	57.91	75.39
Dec	24.42	25.90	24.50	26.20	27.78	35.07	36.07	35.69	38.04	38.24	40.61	41.41	44.23	47.14	50.76	50.06	52.85	58.36	64.13	69.24	69.52	70.34	71.29	80.69	96.11
LLH	2021	2022	2023	2024	2025	2026	2027	2028	2029	2030	2031	2032	2033	2034	2035	2036	2037	2038	2039	2040	2041	2042	2043	2044	2045
Jan	20.71	22.12	19.32	19.54	20.37	24.06	30.78	31.48	34.35	35.39	34.92	36.37	37.02	39.20	42.45	43.55	44.74	46.55	47.59	49.67	52.97	53.45	57.44	61.27	62.63
Feb	17.13	18.01	15.91	15.42	18.11	21.01	26.28	26.39	28.74	28.15	29.42	29.70	34.09	33.72	34.94	35.81	41.06	42.65	42.86	44.59	49.98	48.97	52.49	59.16	63.65
Mar	12.67	12.91	12.55	13.82	14.80	16.71	22.94	22.88	27.96	32.58	43.05	51.43	49.90	62.49	66.45	74.05	73.54	71.61	70.17	66.35	57.80	54.95	47.83	40.07	39.18
Apr	9.85	10.07	11.64	15.53	20.54	22.57	25.15	23.33	26.87	29.06	28.74	36.57	29.27	28.86	36.05	32.80	27.00	33.24	21.58	12.60	9.07	(2.76)	(5.65)	(6.86)	(8.01)
May	(5.62)	(3.69)	(1.54)	(8.96)	(5.44)	(5.74)	(8.23)	(11.58)	(12.17)	(15.65)	(19.62)	(13.55)	(19.16)	(21.27)	(20.42)	(22.38)	(24.60)	(17.58)	(23.33)	(23.33)	(24.65)	(24.78)	(24.23)	(17.14)	(22.34)
Jun	6.82	7.69	7.54	3.33	8.07	4.94	0.85	(5.18)	(7.39)	(11.25)	(16.13)	(14.54)	(14.67)	(16.46)	(18.29)	(19.83)	(18.59)	(17.50)	(16.39)	(15.79)	(18.19)	(21.23)	(19.89)	(17.49)	(9.89)
Jul	14.09	14.22	13.93	13.50	15.78	19.31	19.61	19.28	20.22	20.06	20.91	22.60	23.45	21.23	20.64	17.99	17.42	18.88	18.60	16.12	8.89	4.78	1.97	4.14	10.21
Aug	14.77	15.40	15.23	15.77	18.76	19.88	25.27	23.89	25.04	29.35	31.29	33.61	33.71	36.75	34.58	39.95	44.99	46.68	46.84	49.87	57.08	55.50	57.56	56.60	74.95
Sep	13.46	13.34	16.32	15.56	19.26	19.52	25.43	22.02	28.78	27.19	31.75	31.20	35.18	34.35	38.87	40.77	46.15	45.09	53.14	50.54	60.20	56.14	61.97	63.19	75.66
Oct	12.67	12.69	14.82	14.14	16.60	17.29	21.17	20.76	22.52	23.99	26.54	27.84	31.46	33.27	36.09	37.82	41.42	40.58	48.61	55.99	64.20	71.36	65.67	62.60	72.29
Nov	13.67	14.97	13.15	13.95	15.95	22.33	23.72	23.39	26.07	26.08	29.10	30.37	32.29	34.38	37.45	35.01	38.20	41.50	41.83	43.02	42.54	36.33	51.38	53.61	78.64
Dec	19.21	20.74	18.35	20.77	22.71	28.81	29.97	31.29	33.81	34.24	37.28	39.68	40.73	43.03	44.71	43.78	49.43	53.46	51.82	59.87	58.38	50.97	60.53	63.97	66.23

**Capacity Only Value Assuming Flat Delivery All Hours in a Year -- Example Rates For Large QF Resources, Not Applicable to Small QF**  
**Hourly Values (\$/MWh)**

2021	2022	2023	2024	2025	2026	2027	2028	2029	2030	2031	2032	2033	2034	2035	2036	2037	2038	2039	2040	2041	2042	2043	2044	2045
-	-	-	-	-	-	13.10	13.37	13.64	13.91	14.18	14.47	14.77	15.05	15.36	15.66	15.97	16.29	16.62	16.95	17.29	17.63	17.99	18.35	18.72

1. HLH (heavy load-hours) are defined as 6:00 am until 10:00 pm all days. LLH (light load-hours) are defined as all other hours.
2. Rate does not include adjustments for variable energy resource integration charges.
3. Capacity value is applied to all delivered energy during a calendar year.

### Estimated Avoided Costs

Combined Energy and Capacity Value Assuming Flat Delivery All Hours in a Year -- Example Rates For Large QF Resources, Not Applicable to Small QF  
Hourly Values (\$/MWh)

HLH	2021	2022	2023	2024	2025	2026	2027	2028	2029	2030	2031	2032	2033	2034	2035	2036	2037	2038	2039	2040	2041	2042	2043	2044	2045
Jan	24.43	25.73	22.61	21.92	23.26	27.38	44.95	46.18	48.67	49.84	50.98	51.80	53.67	55.38	57.53	59.40	61.48	63.82	66.02	67.43	71.08	73.99	77.94	83.51	84.81
Feb	20.20	20.90	18.70	17.12	20.23	22.29	39.10	39.91	41.99	42.43	43.28	44.53	47.45	48.39	49.89	50.89	54.42	53.75	54.78	56.47	60.36	58.11	60.78	66.09	71.00
Mar	17.29	18.05	16.87	17.88	17.25	17.73	34.85	35.31	38.99	39.53	47.57	51.52	53.21	62.17	63.67	70.26	63.32	59.08	56.40	51.82	45.28	44.28	43.98	42.00	43.09
Apr	11.27	11.54	12.50	15.27	17.03	18.98	30.35	26.53	27.08	28.67	30.21	35.11	33.33	32.28	36.78	32.60	29.63	29.16	23.56	18.33	18.57	13.04	13.34	13.87	13.37
May	4.19	4.27	5.38	3.73	1.90	1.88	10.06	7.58	8.72	6.94	5.84	7.99	6.29	6.07	7.70	6.71	6.14	7.17	5.69	5.27	5.50	9.03	6.84	12.06	5.48
Jun	12.90	13.08	13.26	15.20	11.82	11.44	23.47	17.42	17.14	12.72	9.01	10.15	10.18	10.71	10.75	9.43	8.98	9.23	9.48	9.16	8.43	6.98	6.58	6.59	22.79
Jul	17.63	18.71	19.54	20.21	21.31	22.63	40.12	38.36	39.93	41.53	38.59	41.69	39.07	35.39	32.23	31.39	31.19	32.35	29.98	28.95	20.50	19.37	21.25	20.86	25.93
Aug	23.01	24.46	24.94	25.02	28.64	28.72	46.80	44.57	46.37	48.17	48.35	49.44	49.61	50.82	51.48	57.46	55.27	55.92	54.23	57.60	50.62	50.11	51.59	53.23	63.88
Sep	21.49	22.18	24.48	22.95	25.95	27.71	44.86	42.61	43.81	44.29	44.74	46.89	48.69	48.43	48.75	50.87	51.81	54.41	59.65	60.13	56.99	55.32	60.42	61.09	66.75
Oct	19.43	20.01	21.18	20.37	23.53	23.91	40.98	38.27	40.71	42.43	41.19	43.67	46.18	47.27	48.67	50.44	53.45	55.02	64.70	61.92	72.68	79.68	74.08	65.33	66.06
Nov	18.66	19.83	18.54	19.75	21.37	25.40	40.43	40.63	43.74	43.59	45.66	45.72	49.00	52.11	56.94	55.65	60.80	64.42	65.90	68.33	76.88	71.54	73.48	76.26	94.10
Dec	24.42	25.90	24.50	26.20	27.78	35.07	49.18	49.06	51.68	52.15	54.79	55.88	58.99	62.19	66.11	65.73	68.83	74.65	80.75	86.20	86.82	87.97	89.27	99.04	114.82
LLH	2021	2022	2023	2024	2025	2026	2027	2028	2029	2030	2031	2032	2033	2034	2035	2036	2037	2038	2039	2040	2041	2042	2043	2044	2045
Jan	20.71	22.12	19.32	19.54	20.37	24.06	43.88	44.85	47.99	49.30	49.11	50.84	51.79	54.25	57.81	59.21	60.71	62.85	64.21	66.62	70.27	71.09	75.43	79.62	81.34
Feb	17.13	18.01	15.91	15.42	18.11	21.01	39.38	39.76	42.37	42.06	43.61	44.17	48.86	48.77	50.30	51.48	57.03	58.94	59.48	61.54	67.27	66.61	70.48	77.51	82.37
Mar	12.67	12.91	12.55	13.82	14.80	16.71	36.05	36.25	41.59	46.50	57.24	65.90	64.66	77.54	81.80	89.72	89.51	87.90	86.79	83.30	75.09	72.59	65.82	58.42	57.89
Apr	9.85	10.07	11.64	15.53	20.54	22.57	38.25	36.69	40.51	42.97	42.92	51.04	44.03	43.91	51.41	48.47	42.97	49.53	38.20	29.55	26.36	14.87	12.34	11.49	10.70
May	(5.62)	(3.69)	(1.54)	(8.96)	(5.44)	(5.74)	4.87	1.79	1.47	(1.74)	(5.43)	0.92	(4.40)	(6.22)	(5.06)	(6.72)	(8.63)	(1.28)	(6.71)	(6.38)	(7.36)	(7.14)	(6.24)	1.21	(3.62)
Jun	6.82	7.69	7.54	3.33	8.07	4.94	13.95	8.18	6.25	2.67	(1.95)	(0.07)	0.10	(1.41)	(2.93)	(4.17)	(2.62)	(1.21)	0.23	1.16	(0.89)	(3.60)	(1.90)	0.86	8.82
Jul	14.09	14.22	13.93	13.50	15.78	19.31	32.72	32.65	33.86	33.97	35.10	37.07	38.22	36.28	36.00	33.65	33.39	35.17	35.22	33.07	26.19	22.41	19.96	22.49	28.93
Aug	14.77	15.40	15.23	15.77	18.76	19.88	38.38	37.25	38.68	43.26	45.48	48.08	48.47	51.80	49.94	55.62	60.96	62.97	63.46	66.82	74.37	73.14	75.54	74.95	93.67
Sep	13.46	13.34	16.32	15.56	19.26	19.52	38.53	35.38	42.42	41.10	45.94	45.67	49.95	49.40	54.22	56.43	62.13	61.38	69.76	67.50	77.50	73.77	79.96	81.54	94.37
Oct	12.67	12.69	14.82	14.14	16.60	17.29	34.27	34.12	36.16	37.90	40.73	42.31	46.22	48.32	51.45	53.48	57.39	56.87	65.23	72.94	81.49	89.00	83.66	80.95	91.00
Nov	13.67	14.97	13.15	13.95	15.95	22.33	36.83	36.76	39.71	39.99	43.29	44.84	47.05	49.43	52.80	50.67	54.17	57.79	58.45	59.97	59.84	53.96	69.36	71.96	97.36
Dec	19.21	20.74	18.35	20.77	22.71	28.81	43.08	44.65	47.44	48.15	51.46	54.15	55.50	58.08	60.07	59.44	65.40	69.75	68.44	76.82	75.67	68.60	78.52	82.32	84.95

1. HLH (heavy load-hours) are defined as 6:00 am until 10:00 pm all days. LLH (light load-hours) are defined as all other hours.
2. After 15 years rates are escalated using growth rate between year 14 and year 15.
3. Rate does not include adjustments for variable energy resource integration charges.



**Schedule 62 QF Avoided Costs**  
**Specified-Term Standard Power & Short-Term Time of Delivery Capacity Rates**  
**Hourly Values (\$/MWh)**

RCW 80.80.40 Compliant Resources - Contracts Ending after 15 Years									
First Delivery Year	Hourly Capacity Value <3 Year History								3+ Year History \$/kW-mo
	On-System Wind	Montana Wind	Solar	Solar + 4Hr Batt	Hydro	Wood Biomass	Geothermal (off sys)	Other	
2022	1.43	5.52	0.75	5.87	14.65	11.55	9.71	8.93	6.52
2023	1.60	6.21	0.84	6.61	16.47	12.99	10.92	10.04	7.33
2024	1.79	6.93	0.94	7.37	18.38	14.49	12.18	11.20	8.18
2025	2.10	8.13	1.10	8.64	21.56	17.00	14.29	13.14	9.59

RCW 80.80.40 Compliant Resources - Renewal Contracts Ending after 10 Years									
First Delivery Year	Hourly Capacity Value <3 Year History								3+ Year History \$/kW-mo
	On-System Wind	Montana Wind	Solar	Solar + 4Hr Batt	Hydro	Wood Biomass	Geothermal (off sys)	Other	
2022	1.02	3.95	0.54	4.20	10.49	8.27	6.95	6.39	4.67
2023	1.25	4.85	0.66	5.16	12.87	10.15	8.53	7.84	5.73
2024	1.50	5.79	0.78	6.16	15.35	12.11	10.17	9.36	6.83
2025	1.92	7.43	1.01	7.90	19.70	15.54	13.05	12.01	8.77

RCW 80.80.40 Non-Compliant Resources - Renewal Contracts Ending after 5 Years									
First Delivery Year	Hourly Capacity Value <3 Year History								3+ Year History \$/kW-mo
	On-System Wind	Montana Wind	Solar	Solar + 4Hr Batt	Hydro	Wood Biomass	Geothermal (off sys)	Other	
2022	0.00	0.00	0.00	0.00	0.00	0.00	0.00	0.00	0.00
2023	0.40	1.54	0.21	1.64	4.09	3.23	2.71	2.49	1.82
2024	0.81	3.15	0.43	3.35	8.36	6.60	5.54	5.10	3.72
2025	1.54	5.97	0.81	6.35	15.84	12.49	10.50	9.66	7.05

- Capacity payments are based on an annual capacity value multiplied by the standardized on-peak capacity contribution divided by a standardized capacity factor. Once QF output exceeds that of the assumed capacity factor level, capacity payments will cease until the next contract year.
- Existing resources with 3 years of operating history will receive a \$/MWh payment derived using the \$/kW-mo rate. To convert the \$/kW-mo rate to a per-MWh rate, multiply the \$/kW-mo rate by 12 months and multiply it again by the capacity contribution factor defined in tariff and then divide that figure by the average capacity factor over the same number of years used to define the capacity contribution factor.
- On-Peak Capacity Contribution Assumptions <3 Years Operating History:  
On-System Wind: 5% Montana Wind: 30% Solar: 2% Solar + 4Hr Battery: 15%  
Hydro: 61% Other: 100%
- Standardized Capacity Factor Assumptions <3 Years Operating History:  
On-System Wind: 31% Montana Wind: 49% Solar: 24% Solar + 4Hr Battery: 23%  
Hydro: 37% Wood Biomass: 77% Geothermal (off-sys): 92%
- Fixed rate is for contracts ending in 2035. Shorter terms will receive capacity payment based on value provided over the term of the contract.
- Capacity contribution payment with batteries is based on the size of the resource itself, not the summation of the battery and resource. Battery size is assumed to be equal to a multiple of the underlying resource capacity (e.g., 2 MW solar + 4 hr battery = 8 MWh battery).

**Schedule 62 QF Avoided Costs**  
**Specified Term—Standard Power Energy Rates**  
**Hourly Values (\$/MWh)**

HLH	2021	2022	2023	2024	2025	2026	2027	2028	2029	2030	2031	2032	2033	2034	2035	2036	2037	2038	2039	2040	2041	2042	2043	2044	2045
Jan	24.43	25.73	22.61	21.92	23.26	27.38	31.85	32.82	35.03	35.93	36.79	37.33	38.90	40.33	42.17	43.74	45.51	47.52	49.40	50.47	53.79	56.36	59.95	65.16	66.09
Feb	20.20	20.90	18.70	17.12	20.23	22.29	25.99	26.54	28.35	28.52	29.10	30.06	32.68	33.34	34.53	35.22	38.44	37.46	38.16	39.52	43.07	40.47	42.79	47.74	52.28
Mar	17.29	18.05	16.87	17.88	17.25	17.73	21.75	21.95	25.35	25.62	33.38	37.05	38.44	47.12	48.31	54.59	47.35	42.79	39.77	34.87	27.99	26.65	26.00	23.65	24.37
Apr	11.27	11.54	12.50	15.27	17.03	18.98	17.25	13.17	13.44	14.76	16.03	20.64	18.57	17.23	21.42	16.94	13.66	12.87	6.94	1.38	1.28	(4.59)	(4.64)	(4.49)	(5.35)
May	4.19	4.27	5.38	3.73	1.90	1.88	(3.04)	(5.79)	(4.92)	(6.97)	(8.35)	(6.48)	(8.48)	(8.98)	(7.66)	(8.96)	(9.83)	(9.12)	(10.93)	(11.68)	(11.79)	(8.60)	(11.15)	(6.29)	(13.24)
Jun	12.90	13.08	13.26	15.20	11.82	11.44	10.37	4.05	3.50	(1.19)	(5.18)	(4.32)	(4.59)	(4.34)	(4.61)	(6.23)	(7.00)	(7.06)	(7.14)	(7.79)	(8.86)	(10.65)	(11.41)	(11.76)	4.07
Jul	17.63	18.71	19.54	20.21	21.31	22.63	27.02	25.00	26.30	27.62	24.41	27.22	24.31	20.34	16.87	15.73	15.22	16.06	13.36	12.00	3.21	1.74	3.27	2.51	7.21
Aug	23.01	24.46	24.94	25.02	28.64	28.72	33.69	31.21	32.73	34.26	34.16	34.97	34.84	35.77	36.12	41.79	39.30	39.63	37.60	40.65	33.33	32.47	33.60	34.88	45.16
Sep	21.49	22.18	24.48	22.95	25.95	27.71	31.76	29.25	30.17	30.38	30.56	32.42	33.92	33.38	33.39	35.20	35.83	38.12	43.03	43.18	39.70	37.69	42.43	42.73	48.04
Oct	19.43	20.01	21.18	20.37	23.53	23.91	27.88	24.91	27.07	28.52	27.00	29.20	31.42	32.22	33.31	34.78	37.47	38.73	48.08	44.96	55.39	62.05	56.09	46.98	47.34
Nov	18.66	19.83	18.54	19.75	21.37	25.40	27.33	27.27	30.10	29.68	31.47	31.25	34.24	37.06	41.58	39.99	44.82	48.13	49.28	51.38	59.59	53.91	55.49	57.91	75.39
Dec	24.42	25.90	24.50	26.20	27.78	35.07	36.07	35.69	38.04	38.24	40.61	41.41	44.23	47.14	50.76	50.06	52.85	58.36	64.13	69.24	69.52	70.34	71.29	80.69	96.11
LLH	2021	2022	2023	2024	2025	2026	2027	2028	2029	2030	2031	2032	2033	2034	2035	2036	2037	2038	2039	2040	2041	2042	2043	2044	2045
Jan	20.71	22.12	19.32	19.54	20.37	24.06	30.78	31.48	34.35	35.39	34.92	36.37	37.02	39.20	42.45	43.55	44.74	46.55	47.59	49.67	52.97	53.45	57.44	61.27	62.63
Feb	17.13	18.01	15.91	15.42	18.11	21.01	26.28	26.39	28.74	28.15	29.42	29.70	34.09	33.72	34.94	35.81	41.06	42.65	42.86	44.59	49.98	48.97	52.49	59.16	63.65
Mar	12.67	12.91	12.55	13.82	14.80	16.71	22.94	22.88	27.96	32.58	43.05	51.43	49.90	62.49	66.45	74.05	73.54	71.61	70.17	66.35	57.80	54.95	47.83	40.07	39.18
Apr	9.85	10.07	11.64	15.53	20.54	22.57	25.15	23.33	26.87	29.06	28.74	36.57	29.27	28.86	36.05	32.80	27.00	33.24	21.58	12.60	9.07	(2.76)	(5.65)	(6.86)	(8.01)
May	(5.62)	(3.69)	(1.54)	(8.96)	(5.44)	(5.74)	(8.23)	(11.58)	(12.17)	(15.65)	(19.62)	(13.55)	(19.16)	(21.27)	(20.42)	(22.38)	(24.60)	(17.58)	(23.33)	(23.33)	(24.65)	(24.78)	(24.23)	(17.14)	(22.34)
Jun	6.82	7.69	7.54	3.33	8.07	4.94	0.85	(5.18)	(7.39)	(11.25)	(16.13)	(14.54)	(14.67)	(16.46)	(18.29)	(19.83)	(18.59)	(17.50)	(16.39)	(15.79)	(18.19)	(21.23)	(19.89)	(17.49)	(9.89)
Jul	14.09	14.22	13.93	13.50	15.78	19.31	19.61	19.28	20.22	20.06	20.91	22.60	23.45	21.23	20.64	17.99	17.42	18.88	18.60	16.12	8.89	4.78	1.97	4.14	10.21
Aug	14.77	15.40	15.23	15.77	18.76	19.88	25.27	23.89	25.04	29.35	31.29	33.61	33.71	36.75	34.58	39.95	44.99	46.68	46.84	49.87	57.08	55.50	57.56	56.60	74.95
Sep	13.46	13.34	16.32	15.56	19.26	19.52	25.43	22.02	28.78	27.19	31.75	31.20	35.18	34.35	38.87	40.77	46.15	45.09	53.14	50.54	60.20	56.14	61.97	63.19	75.66
Oct	12.67	12.69	14.82	14.14	16.60	17.29	21.17	20.76	22.52	23.99	26.54	27.84	31.46	33.27	36.09	37.82	41.42	40.58	48.61	55.99	64.20	71.36	65.67	62.60	72.29
Nov	13.67	14.97	13.15	13.95	15.95	22.33	23.72	23.39	26.07	26.08	29.10	30.37	32.29	34.38	37.45	35.01	38.20	41.50	41.83	43.02	42.54	36.33	51.38	53.61	78.64
Dec	19.21	20.74	18.35	20.77	22.71	28.81	29.97	31.29	33.81	34.24	37.28	39.68	40.73	43.03	44.71	43.78	49.43	53.46	51.82	59.87	58.38	50.97	60.53	63.97	66.23

1. New resources must sign contracts through the end of 2035. Existing resources must execute 10-year contracts. Resources not RCW 80.80.40 compliant must execute 5-year contracts. All new resource contracts must begin delivery within 3 years of execution; renewal QF contract terms must begin at time of existing contract expiration.
2. HLH (heavy load-hours) are defined as 6:00 am until 10:00 pm all days. LLH (light load-hours) are defined as all other hours.
3. QF may cease deliveries during periods where prices are negative.



# 2021 Electric Integrated Resource Plan

## Appendix G – Transmission 10- year plan (2020) and 2019-2020 Avista System Assessment



# 2020 Avista System Plan

*Prepared By: System Planning*



**SADDLE MOUNTAIN STATION UNDER CONSTRUCTION**

Version	Version Date	Action	Prepared By	Reviewed By
A	Nov 19, 2020	Draft posted for stakeholder review	John Gross	Damon Fisher
0	Dec 18, 2020	Finalized following stakeholder review	John Gross	David Thompson

# TABLE OF CONTENTS

- I SYSTEM PLANNING OVERVIEW .....3
- II SYSTEM PROJECT LIST ..... 5
- III MAJOR SYSTEM PROJECTS ..... 15
  - 1 COEUR D'ALENE SYSTEM REINFORCEMENT .....15
  - 2 METRO STATION REBUILD .....17
  - 3 SUNSET STATION REBUILD ..... 18
  - 4 WEST PLAINS SYSTEM REINFORCEMENT ..... 19
  - 5 WESTSIDE STATION REBUILD .....20

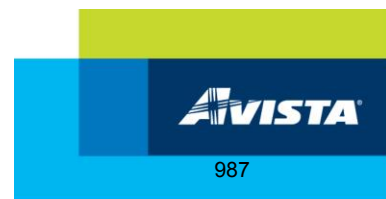

# I SYSTEM PLANNING OVERVIEW

Avista's System Planning department's core responsibilities include the development of a system plan for system reinforcements to meet transmission system needs for load growth, adequate transfer capability, requests for generation interconnections, line and load interconnections, and long-term firm transmission service.

The development of the system plan follows a two-year process with four phases. Stakeholders have opportunities to participate in the development of the system plan by collaborating with System Planning and providing comments.

- Phase 1 includes establishing the assumptions and models for use in the technical studies, developing and finalizing a Study Plan, and specifying the public policy mandates planners will adopt as objectives in the current study cycle.
- Phase 2 includes performing necessary technical studies and development of the Planning Assessment. The results of the technical studies are documented in the Planning Assessment, including conceptual solutions to mitigate performance issues.
- Phase 3 includes providing the Avista System Plan report to stakeholders. The Avista System Plan will include documentation of the electrical infrastructure plan with preferred solution options. The resulting project list will include additional information regarding projects and system modifications developed through means other than the technical studies.<sup>1</sup>
- Phase 4 comprises the majority of year two in the two-year process and includes refining the preferred plan of service. Conceptual projects identified in Phase 2 which have not been fully developed in Phase 3 will be addressed in Phase 4.

---

<sup>1</sup> Such other means may include, for example, generation interconnection or transmission service request study processes under the OATT, or joint study team processes within the region.

Figure 1 provides a visual representation of the four phases throughout the two-year process.

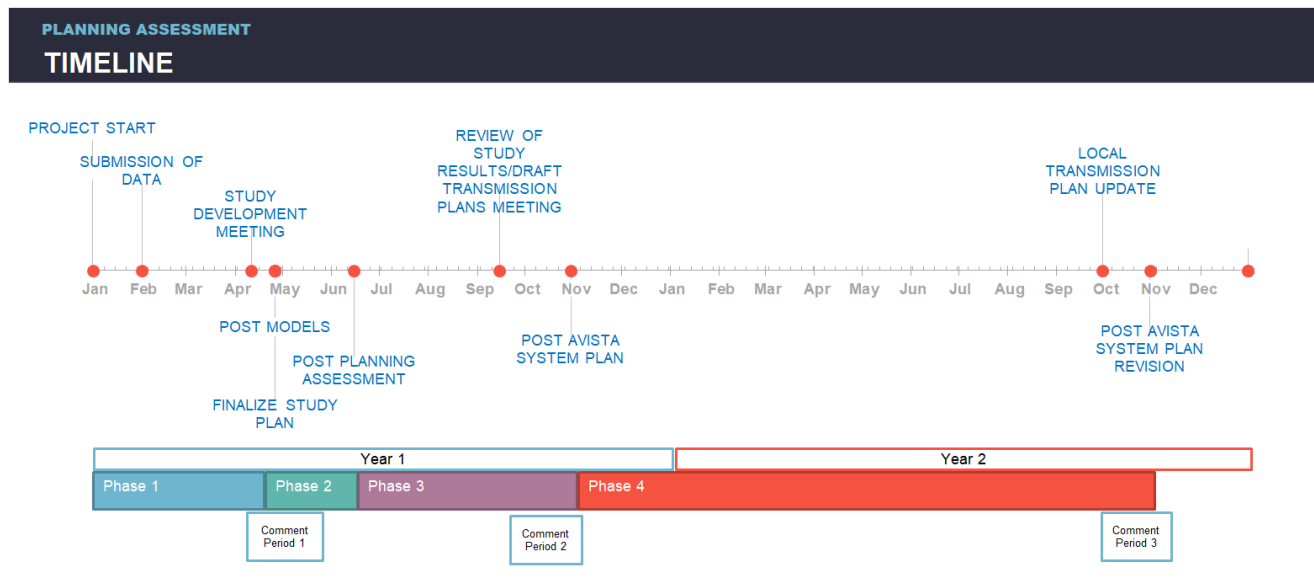

FIGURE 1: AVISTA PLANNING ASSESSMENT TIMELINE



## II SYSTEM PROJECT LIST

Initiative	#	Project Name	Driver	Scope	Targeted Date of Operation	Status	Included in Transmission Model
Big Bend System Reinforcement	-	Bruce Siding Station	Performance & Capacity	Scope not complete. New distribution station along Othello SS – Warden #2 115kV transmission line. Station may be an interconnection point for new transmission line used to integrate proposed renewable generation.	N/A	Conceptual Not Scoped	
	32	Davenport Station Rebuild	Asset Condition	Rebuild existing distribution station at nearby greenfield site. Initial construction will include single 20MVA transformer with three feeders.	Q3 2022	Budgeted	
	37	Little Falls Station Rebuild	Asset Condition	Scope not complete. Rebuild existing station in place.	Q4 2023	Budgeted Not Scoped	
	117	Sprague Station Rebuild	Asset Condition	Scope not complete. Rebuild existing distribution station.	N/A	Conceptual Not Scoped	
	-	Benton – Othello 115kV Transmission Line Rebuild	Mandatory & Compliance	Reconductor Avista's 26-mile section of the Benton – Othello Switching Station 115kV transmission line with 795 ACSS with a minimum thermal capacity of 205MVA at 40°C.	Completed Q2 2020	Complete	YES
	-	Chelan Stratford 115kV Transmission Line Rebuild	Performance & Capacity	Scope not complete. Reconductor entire 35.1 miles of Chelan – Stratford 115kV transmission line and 1.2 miles of 115kV line from Headwork tap to Coulee City with 795 ACSS, with a minimum thermal capacity of 205MVA at 40°C.	N/A	Conceptual Not Scoped	
	122	Devils Gap – Lind 115kV Transmission Line Rebuild	Asset Condition	Transmission line minor rebuild to address age and condition of assets.		Construction	
Cabinet Gorge GSU Isolation	82	Cabinet Gorge GSU Protection Upgrade	Performance & Capacity	Install circuit breakers on high side of GSU.	Q4 2024	Budgeted	
Coeur d'Alene System Reinforcement	-	Canfield Station	Performance & Capacity	Scope not complete. New distribution station.	N/A	Conceptual Not Scoped	
	5	Dalton Station Rebuild	Performance & Capacity	Rebuild existing distribution station to two 30MVA transformers, six feeders, and looped-through transmission with circuit breakers.	Q3 2020	Complete	

## System Plan | 2020

Initiative	#	Project Name	Driver	Scope	Targeted Date of Operation	Status	Included in Transmission Model
	-	Pleasant View Station	Performance & Capacity	Scope not complete. Rebuild existing station.	N/A	Conceptual Not Scoped	
	105	Rathdrum Distribution Expansion	Performance & Capacity	Scope not complete. Increase existing distribution capacity.	N/A	Conceptual Not Scoped	
	80	Huetter Station Expansion	Performance & Capacity	Scope not complete. Rebuild existing distribution station to two 30MVA transformers, six feeders, and looped-through transmission with circuit breakers.	Q4 2023	Budgeted Not Scoped	
	-	Coeur d'Alene – Pine Creek 115kV Transmission Line Rebuild	Mandatory & Compliance	Reconductor Coeur d'Alene - Pine Creek 115kV transmission line with 1272 ACSR conductor and operate normally open switch as closed.	Completed Q4 2019	Complete	YES Open
	46	Poleline (Prairie) Station Rebuild	Performance & Capacity	Scope not complete. Construct new distribution station to replace Avista facilities at existing Prairie Station. New station to include two 30MVA transformers, six feeders, and looped-through transmission with circuit breakers.	Q4 2023	Budgeted Not Scoped	
	-	Magic Corner	Performance & Capacity	Convert the Ramsey – Rathdrum #3 and Boulder – Post Falls 115kV transmission lines into Boulder – Rathdrum and Post Falls – Ramsey 115kV transmission lines by swapping jumpers on the “magic corner” pole where the transmission lines intersect. Changing the transmission lines will allow the Coeur d'Alene – Pine Creek 115kV transmission line to be operated normally closed.	Q2 2021		NO
<b>East Coeur d'Alene Lake System Reinforcement</b>	12	Carlin Bay Station	Performance & Capacity	Construct new distribution station to include single 20MVA transformer and three feeders. Transmission integration to include constructing a new radial transmission line from O'Gara Station to Carlin Bay and rebuilding the existing O'Gara Station to a switching station. New microwave communication paths will be established to O'Gara Station.	Q1 2025	Budgeted	
	89	Saint Maries Station Expansion	Performance & Capacity	Construct a fourth distribution feeder at the existing Saint Maries Station. SCADA and communication infrastructure will be added.	Q1 2022	Budgeted	

## System Plan | 2020

Initiative	#	Project Name	Driver	Scope	Targeted Date of Operation	Status	Included in Transmission Model
	128	Benewah – Pine Creek 230kV Transmission Line Rebuild	Asset Condition	Scope not complete. Design 2025 Rebuild transmission line.	N/A	Conceptual Not Scoped	
Idaho/Lewis County System Reinforcement	34	Grangeville Station Rebuild	Asset Condition	Rebuild existing station to include a main bus with transmission lines terminated at circuit breakers. New distribution facilities to include a 13.2kV and a 34.5kV transformer.	N/A	Conceptual	
	36	Kooskia Station Rebuild	Asset Condition	Scope not complete. Rebuild existing distribution station. Initial construction will include single 20MVA transformer with two feeders.	Q4 2025	Budgeted Not Scoped	
Kettle Falls Stability	96	Kettle Falls Protection System Upgrade	Mandatory & Compliance	Upgrade existing protection schemes on the Addy – Kettle Falls and Colville – Kettle Falls 115kV transmission lines. New relays at Kettle Falls Station and a new communication path from Kettle Falls to Mount Monumental are required.	2022	Budgeted	NO
Lewiston/Clarkston System Reinforcement	64	Hatwai – Lolo #2 230kV Transmission Line	Mandatory & Compliance	Scope not complete. Construct new 230kV transmission line from Hatwai to Lolo, new transmission line terminal at Lolo Station and request interconnection at BPA's Hatwai Station.	2025	Budgeted Not Scoped	
	6	LOID Station	Customer Requested	Scope not complete. New distribution station in the Lewiston Orchards area.	Q4 2025	Budgeted Not Scoped	
	108	Wheatland Station	Performance & Capacity	Scope not complete. New distribution station in the Lewiston area.	N/A	Conceptual Not Scoped	
	109	Tenth & Stewart Station Expansion	Performance & Capacity	Scope not complete. Rebuild and expand existing distribution station.	N/A	Conceptual Not Scoped	
	42	Bryden Canyon Station	Asset Condition	Scope not complete. New distribution station to replace existing distribution facilities at South Lewiston Station.	Q1 2023	Budgeted Not Scoped	
	42	South Lewiston Station Rebuild	Asset Condition	Scope not complete. Rebuild existing station including relocating distribution facilities to Bryden Canyon Station and constructing a switching station with circuit breaker terminated transmission lines.	Q1 2023	Budgeted Not Scoped	NO

## System Plan | 2020

Initiative	#	Project Name	Driver	Scope	Targeted Date of Operation	Status	Included in Transmission Model
	79	Dry Gulch Station Upgrade	Customer Requested	Upgrade of facilities for the replacement of PacifiCorp's 69kV transformer with the 69kV transmission line to be operated normally open.	2020	Complete	NO
	62	Lolo Transformer Replacement	Mandatory & Compliance	Replace Lolo #1 230/115kV transformer with 250MVA rated transformer. Replace Lolo #2 230/115kV transformer with 250MVA rated transformer. 115kV circuit breakers, bus work and other capacity-limiting elements will be replaced. Circuit switchers at Lolo and Sweetwater stations will be replaced.	Q3 2023 Q3 2024	Budgeted	NO
	41	Pound Lane Station Rebuild	Asset Condition	Scope not complete. Rebuild existing distribution station.	N/A	Conceptual Not Scoped	
	124	Lolo – Oxbow 230kV Transmission Line Rebuild	Asset Condition	Rebuild transmission line.	Q2 2021 for first phase 2025 for completion	Budgeted	
<b>Metro Station Rebuild</b>	125	Downtown Transmission Cable Replacement	Asset Condition	Replace existing Metro – Post Street and Post Street – Third & Hatch 115kV transmission line cables with 1500 kcmil XLPE.	Q1 2021	Construction	NO
	38	Metro Station Rebuild	Asset Condition	Rebuild existing substation at new location. 115kV bus to be a 6-position ring: 2 – 30MVA xfmr's, 2 – 115kV UG lines from PST, 2 – 115kV OH lines; switchgear on the 13kV side, both Network and Distribution feeders	Q1 2024	Budgeted	YES
<b>North Spokane System Reinforcement</b>	81	Beacon – Francis & Cedar – Waikiki Reconfiguration	Performance & Capacity	Scope not complete. Request new interconnection to Bell Station and loop existing Beacon – Francis & Cedar 115kV transmission line into Bell Station. Waikiki Station can then be served normally by the Bell – Francis & Cedar line.	N/A	Conceptual Not Scoped	
	129	Mead – Colbert – Milan 115kV Transmission Line	Performance & Capacity	Scope not complete. Construct a new 115kV transmission line starting from north Spokane to pick up Mead, Colbert, and Milan stations.	N/A	Budgeted Not Scoped	
	50	Florida & Dalke Station	Performance & Capacity	Scope not complete. New distribution station on the Beacon – Bell	Q4 2025	Budgeted Not Scoped	

## System Plan | 2020

Initiative	#	Project Name	Driver	Scope	Targeted Date of Operation	Status	Included in Transmission Model
				#1 115kV transmission line in the Hillyard area.			
	15	Hawthorne Station	Performance & Capacity	Scope not complete. New switching station with distribution facilities located in north Spokane near Bell Station. 115kV interconnection will be along the Beacon – Francis & Cedar corridor and can be a starting point for new transmission line toward Mead Station.	Q4 2025	Budgeted Not Scoped	
	98	Midway Station	Performance & Capacity	Scope not complete. New distribution station located north of Spokane along the Bell – Addy 115kV transmission line.	Q1 2023	Budgeted Not Scoped	
	106	Waikiki Station Expansion	Performance & Capacity	Scope not complete. Increase existing distribution capacity at Waikiki Station.	N/A	Conceptual Not Scoped	
	111	Lyons & Standard Station Expansion	Performance & Capacity	Scope not complete. Increase existing distribution capacity at Lyons & Standard Station.	N/A	Conceptual Not Scoped	
	40	Northwest Station Rebuild	Asset Condition	Scope not complete. Rebuild existing Northwest Station.	Q4 2024	Budgeted Not Scoped	
<b>Palouse System Reinforcement</b>	2	Center Street Station	Performance & Capacity	Scope not complete. New distribution station located in the Pullman area.	2025	Budgeted Not Scoped	
	47	Stateline Station	Performance & Capacity	Scope not complete. New distribution station located between Pullman and Moscow.	Q1 2024	Budgeted Not Scoped	
		Tamarack Station	Performance & Capacity	Scope not complete. New distribution station located in the Moscow area.	N/A	Conceptual Not Scoped	
	112	Moscow City Station Rebuild	Asset Condition	Scope not complete. Rebuild existing Moscow City Station.	N/A	Conceptual Not Scoped	
		North Moscow Station Expansion	Performance & Capacity	Scope not complete. Increase distribution capacity at the existing North Moscow Station.	N/A	Conceptual Not Scoped	
	77	Palouse Area Transformation	Mandatory & Compliance	Scope not complete. Install new 230/115kV transformer at Shawnee Substation with low- and high-side breakers	N/A	Conceptual Not Scoped	

## System Plan | 2020

Initiative	#	Project Name	Driver	Scope	Targeted Date of Operation	Status	Included in Transmission Model
	114	Potlach Station Rebuild	Asset Condition	Install breaker at high-side of Shawnee 230/115kV No. 1 XFMR Scope not complete. Rebuild existing Potlach Station.	N/A	Conceptual Not Scoped	
Rattlesnake Flat I Wind Integration	99	Neilson Station	Customer Requested	Build new 115kV Switching Station for Saddle Mtn POI. Initial configuration 3-terminal ring; final 6-terminal breaker and a half.	Q3 2020	Complete	YES
	99	Lind – Warden 115kV Transmission Line Rebuild	Customer Requested	Upgrade existing Lind – Warden 115kV transmission line to 314MVA capacity including upgrades to terminal equipment at each station. New conductor is 795 ACSS.	Q4 2019	Complete	YES
	99	Lind – Washtucna 115kV Transmission Line Rebuild	Customer Requested	Upgrade existing Lind – Washtucna 115kV transmission line between Lind and the new Nielson Station to 314MVA capacity including upgrades to terminal equipment at Lind Station. New conductor is 795 ACSS.	Q4 2019	Complete	YES
Saddle Mountain	75	Saddle Mountain Station	Mandatory & Compliance	Construct a 3-position 230kV DBDB arrangement with space for two future positions at the line crossing of the Walla Walla – Wanapum 230kV and Benton – Othello 115kV Lines Construct a 4-position 115kV breaker and a half arrangement with space for four future positions Install 1-230/115kV transformer rated at 250MVA.	Q4 2020	Construction	YES
	75	Othello SS – Warden #1 115kV Transmission Line Upgrade	Mandatory & Compliance	Reconstruct Othello SS – Warden #1 115kV transmission line to minimum 205MVA including upgrades to terminal equipment at both stations.	Q1 2019	Complete	YES
	75	Othello SS – Warden #2 115kV Transmission Line Upgrade	Mandatory & Compliance	Reconstruct Othello SS – Warden #2 115kV transmission line to minimum 205MVA including upgrades to terminal equipment at all stations.	Q4 2021	Construction	YES
	75	Othello – Saddle Mountain 115kV Transmission Line	Mandatory & Compliance	Construct 11 miles of 115kV line with a minimum summer rating of 205MVA from Saddle Mountain Station to the new Othello City station with a N/O tap to existing S. Othello Station.	Q4 2021	Construction	NO

## System Plan | 2020

Initiative	#	Project Name	Driver	Scope	Targeted Date of Operation	Status	Included in Transmission Model
	75	Othello Station Rebuild	Mandatory & Compliance	Reconstruct Othello Station to a 3-position breaker and a half with 2 – 30MVA transformers at new property.	Q3 2022	Construction	NO
<b>Sandpoint System Reinforcement</b>	56	Bronx Station Rebuild	Performance & Capacity	Scope not complete. Reconstruct existing Bronx Station to include distribution facilities.	2025	Budgeted Not Scoped	
	74	Sandpoint Transmission Addition	Mandatory & Compliance	Scope not complete. Build a new 37-mile line from Rathdrum to Sandpoint with a conductor capable of providing a minimum of 205MVA capacity. Add three circuit breakers at Sandpoint Substation. Add a position and circuit breaker at Rathdrum Substation.	N/A	Conceptual Not Scoped	
	-	Cabinet – Bronx – Sand Creek 115kV Transmission Line Upgrade	Mandatory & Compliance	Upgrade the Bronx – Cabinet and Bronx – Sand Creek 115kV transmission lines to 205MVA capacity including terminal equipment at all stations.	2017	Complete	YES
	70	Cabinet – Noxon 230kV Transmission Line Rebuild	Performance & Capacity	Reconductor entire 18.51 miles of line to 1590 ACSS.	N/A	Conceptual Not Scoped	
<b>Silver Valley System Reinforcement</b>	90	Mission Station Expansion	Performance & Capacity	Scope not complete. Increase distribution capacity at the existing North Moscow Station.	N/A	Conceptual Not Scoped	
	29	Big Creek Station Rebuild	Asset Condition	Scope not complete. Rebuild existing Big Creek Station.	2025	Budgeted Not Scoped	
	126	Noxon – Pine Creek 230kV Transmission Line Rebuild	Asset Condition	Scope not complete. Reconductor 42.87 miles of 43.51 miles of line to 1590 ACSS. Existing line is partially constructed as double circuit transmission line.	2025	Budgeted Not Scoped	
<b>South Spokane System Reinforcement</b>	67	Ninth & Central 230kV Expansion	Mandatory & Compliance	Scope not complete. Build new Ninth and Central 230kV Double Bus Double Breaker substation to include 1-230/115kV (250MVA) transformer associated with two Circuit Breakers. Loop Beacon – Bell No.4 or No.5 230kV Line to reconfigure to Bell – Ninth and Central 230kV Line. Build new 230kV line section from Beacon to Ninth and Central alongside existing 115kV	N/A	Conceptual Not Scoped	

## System Plan | 2020

Initiative	#	Project Name	Driver	Scope	Targeted Date of Operation	Status	Included in Transmission Model
				line (Either Beacon – Ninth and Central No. 1 or No. 2 115kV Line is adequate.			
	54	Downtown West Station	Performance & Capacity	Scope not complete. New distribution station located on the Metro – Sunset 115kV transmission line.	2025	Budgeted Not Scoped	
	55	East Central New Substation	Performance & Capacity	Scope not complete. New distribution station located on the Ninth & Central – Third & Hatch 115kV transmission line.	2024	Budgeted Not Scoped	
	44	Southeast Station Expansion	Performance & Capacity	Replace 20MVA XFMR#2 with 30MVA and add sixth feeder (Complete). Upgrade 115kV loop-through with capacity for 314MVA.	Transmission Q4 2021	Construction	YES
	110	College & Walnut Station Rebuild	Asset Condition	Scope not complete. Rebuild existing College & Walnut Station.	N/A	Conceptual Not Scoped	
	60	Ninth & Central – Sunset 115kV Transmission Line Upgrade	Performance & Capacity	Replace the 795 AAC and ACSR conductor on the Ninth & Central – Sunset 115kV transmission line with 795 ACSS with E3X coating to match the rest of the line.	Q3 2023	Budgeted	NO
	93	Beacon – Ross Park 115kV Transmission Line Rebuild	Mandatory & Compliance	Rebuild existing Beacon – Ross Park 115kV transmission line. No capacity increase.	2021	Budgeted	
<b>Spokane Valley Transmission Reinforcement</b>	59	Irvin Station	Mandatory & Compliance	Construct the Irvin Station terminating the Beacon – Boulder #1 and #2, Irvin – IEP, and Irvin – Opportunity 115kV transmission lines as a breaker and a half configuration	Q1 2022 Partially Complete	Construction	YES
	49	Irvin Distribution	Performance & Capacity	Scope not complete. Add distribution facilities to Irvin Station.	N/A	Conceptual Not Scoped	
	30	Chester Station Rebuild	Asset Condition	Scope not complete. Rebuild existing Chester Station.	N/A	Conceptual Not Scoped	
	57	Barker Station Expansion	Performance & Capacity	Scope not complete. Increase capacity at existing Barker Station.	N/A	Conceptual Not Scoped	
	123	Beacon – Boulder #1 115kV Transmission Line Rebuild	Asset Condition	Rebuild the existing Beacon – Boulder #1 115kV transmission line from Irvin to SIP.	2022	Budgeted	NO
	59	Beacon – Boulder #2 115kV Transmission Line Rebuild	Mandatory & Compliance	Rebuild the existing Beacon – Boulder #2 115kV transmission line from Beacon to Millwood to 795 ACSS conductor.	N/A	Deferred	NO
	43	Valley Station Rebuild	Asset Condition	Scope not complete. Rebuild existing Valley Station.	Q4 2024	Budgeted Not Scoped	



## System Plan | 2020

Initiative	#	Project Name	Driver	Scope	Targeted Date of Operation	Status	Included in Transmission Model
<b>Stevens/Ferry County System Reinforcement</b>	-	Addy – Devils Gap 115kV Transmission Line Upgrade	Asset Condition	Reconductor 5.19 miles (rebuild between Ford and Long Lake Tap) of limiting conductor which consist of 266.8 ACSR and 397.5 ACSR conductor resulting in a capacity limitation of 71.5MVA at 40°C, to be rebuilt to a capacity of 150MVA at 40°C (likely 240MVA)	Q1 2019	Complete	YES
	91	Long Lake Station Rebuild	Asset Condition	Scope not complete. Relocation of existing GSU transformer from within Long Lake HED to an outside station. Existing 115kV station is located in the powerhouse and will be relocated to an adjacent outdoor site.	N/A	Conceptual Not Scoped	
	101	Long Lake Station Expansion	Performance & Capacity	Scope not complete. Increase capacity of the distribution facilities at the Long Lake distribution station.	N/A	Conceptual Not Scoped	
	8	Addy – Gifford 115kV Transmission Line Rebuild	Asset Condition	Scope not complete. Reconstruct portions of the radial Addy – Gifford 115kV transmission line.	2026	Budgeted Not Scoped	
<b>Sunset Station Rebuild</b>	26	Sunset Station Rebuild	Mandatory & Compliance	Rebuild the existing Sunset Station as breaker and a half configuration.	Q2 2022	Construction	
<b>West Plains System Reinforcement</b>	53	Flint Road Station	Performance & Capacity	Scope not complete. New distribution station located north of Spokane along the Airway Heights - Sunset 115kV transmission line.	Q3 2022	Budgeted Not Scoped	
	104	Four Lakes Capacitor	Performance & Capacity	Scope not complete. Install capacitors at the existing Four Lakes Station.	N/A	Conceptual Not Scoped	
	100	Melville Station	Performance & Capacity	Scope not complete. New switching station near existing tap to Four Lakes Station off the South Fairchild Tap 115kV transmission line. Construct new transmission line from Airway Heights to Melville including passing through Russel Road and Craig Road distribution stations. Requires new transmission line terminal at existing Airway Heights Station.	Q1 2025	Budgeted Not Scoped	
	-	Russel Road	Performance & Capacity	Scope not complete. New distribution station located south of	N/A	Conceptual Not Scoped	

# System Plan | 2020

Initiative	#	Project Name	Driver	Scope	Targeted Date of Operation	Status	Included in Transmission Model
				Airway Heights along the new Airway Heights - Melville 115kV transmission line.			
	131	Garden Springs 115kV Station	Performance & Capacity	Construct new 115kV portion of Garden Springs Station at the existing Garden Springs switching location. New station will terminate Airway Heights – Sunset and Sunset – Westside 115kV transmission lines including the South Fairchild Tap.	Q4 2024	Budgeted	
	131	Garden Springs 230kV Station	Performance & Capacity	Construct new 230kV portion of Garden Springs Station including two 250MVA nominal 230/115kV transformers. Construct new 230kV transmission line from Garden Springs to a new switching station at interconnection point on the BPA Bell – Coulee #5 230kV transmission line.	N/A	Budgeted	
<b>Westside Station Rebuild</b>	58	Westside Station Rebuild	Mandatory & Compliance	Replace the existing Westside #2 230/115kV transformer and construct necessary bus work and breaker positions. Reconstruct 230 and 115kV buses to double bus double breaker 3000/2000 Amp standard. Phase 4: Complete bus work to double bus, double breaker on both the 230kV and 115kV buses	XFMR and 230 2x2 Q1 2021 Q3 2024 for complete rebuild	Construction	YES

## III MAJOR SYSTEM PROJECTS

The following list is a subset of the project list provided in Section II. The subset of projects was selected based on their relative impact to the system performance and the project scope has been substantially determined. A general problem statement and summary of project scope is provided. Detailed project reports may be available and could have more recent information.

### 1 COEUR D'ALENE SYSTEM REINFORCEMENT

The Coeur d'Alene and Post Falls areas in northern Idaho have seen high load growth rates which are expected to continue. Area distribution stations are becoming heavy loaded with equipment operating above 80% of their applicable facility ratings in peak summer scenarios. The local transmission system is served by two 230/115kV autotransformers and a single 115kV transmission line. An additional transmission line can connect to the area but has been historically operated normally open. The autotransformers along with the 115kV transmission lines feeding Coeur d'Alene load may overload for multiple contingency events during moderate to heavy loading during all seasons.

The Coeur d'Alene System Reinforcement initiative includes several projects intended to increase distribution system capacity. Rebuilds and expansion of existing stations at Pleasant View, Rathdrum, Huetter and Prairie will provide increased transformation capacity and additional feeders to serve the area. The Magic Corner project, which changes the Boulder – Post Falls and Ramsey – Rathdrum 115kV transmission lines into the Boulder – Rathdrum and Post Falls – Rathdrum 115kV transmission lines, will allow the Coeur d'Alene – Pine Creek 115kV transmission line to be operated normally closed. Operating the transmission line normally closed provides an additional transmission source into the area.

- 1 Modify "Magic Corner" pole located at Poleline and Chase to convert the Boulder – Post Falls and Ramsey – Rathdrum #3 115 kV transmission lines into the Boulder – Rathdrum and Post Falls – Ramsey 115 kV transmission line.
- 2 Operate switch A429 at Blue Creek on the Coeur d'Alene – Pine Creek 115 kV Transmission Line normally closed. Not shown on drawing.

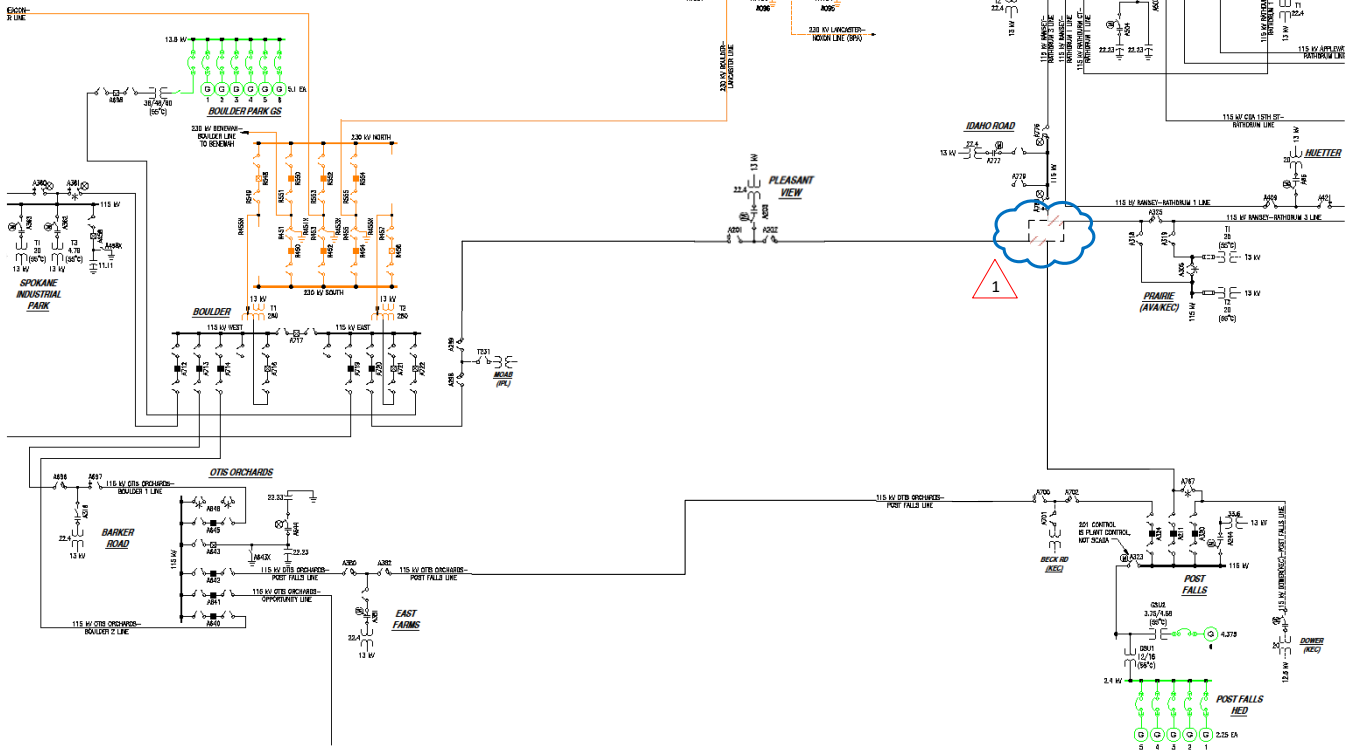

FIGURE 2: MAGIC CORNER PROJECT DIAGRAM

## 2 METRO STATION REBUILD

Metro Station, located in downtown Spokane, is one of two stations serving the downtown distribution network. Much of the major equipment in this station is now unsupported by the manufacturer. Legacy oil tanks beneath the site pose an environmental problem and limit modifications to upgrade the existing station. Underground transmission cables to this site in need replacement. Transformer and switchgear spares are unavailable or difficult to install in an outage scenario. Various other condition issues, such as the 115kV breakers, insulators, and panel house, also exist at this site.

The Metro Station Rebuild project is a full rebuild of the station on a green field site. In addition to the existing Metro – Sunset and Metro – Post Street lines, the Post Street – Third & Hatch line will now be terminated in the Metro station to provide additional transmission configurations to support the network load served out of Metro station and to provide additional redundancy and resiliency options throughout the Spokane urban area.

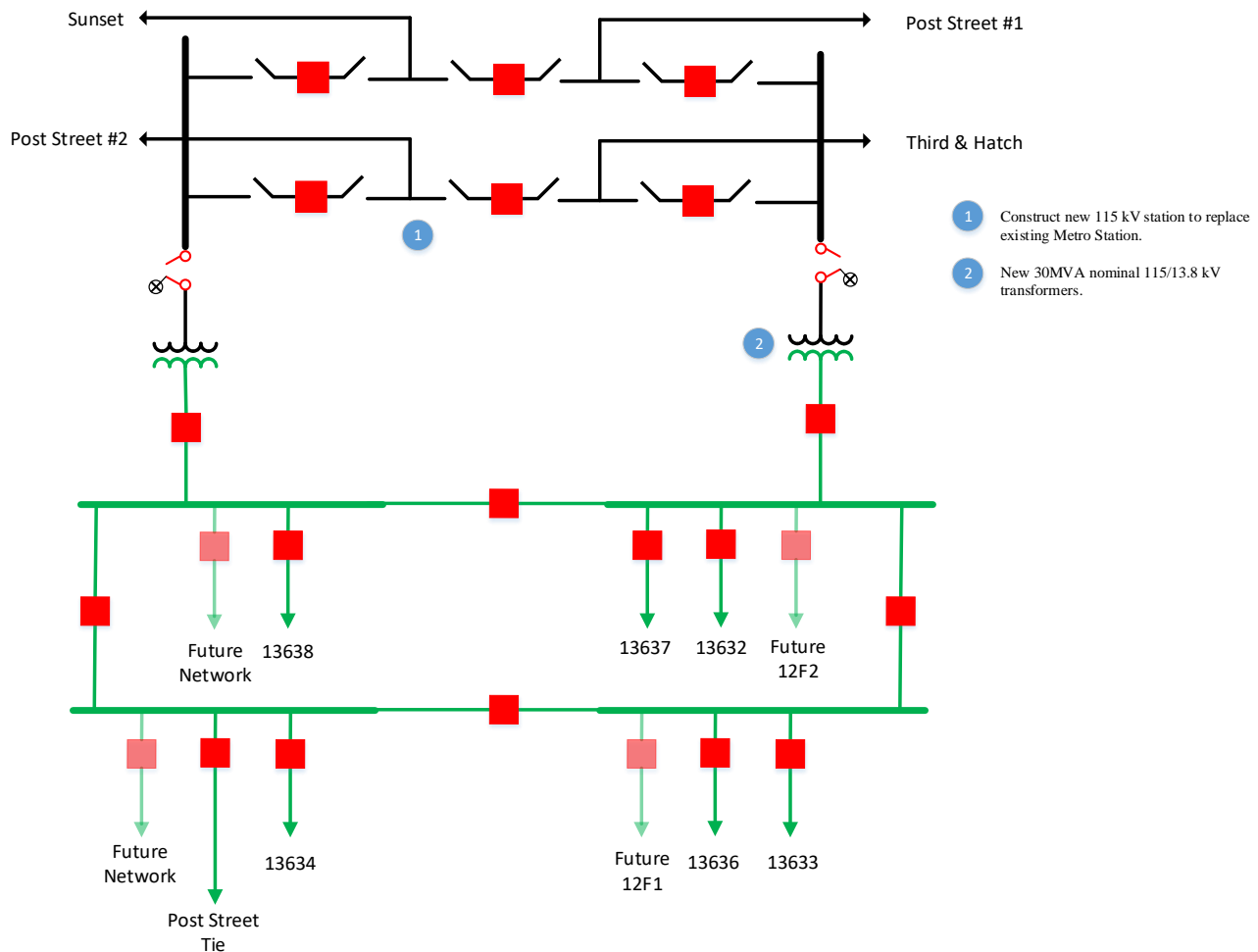

FIGURE 3: METRO STATION REBUILD PROJECT DIAGRAM

### 3 SUNSET STATION REBUILD

The existing circuit breakers at the Sunset Station do not have sufficient short circuit interrupting capability for close-in faults on the connected transmission lines. The available fault current increases with the necessary transmission system expansion to address other system deficiencies (i.e. Westside transformer replacement).

The Sunset Station Rebuild project is a complete station rebuild on adjacent property to the existing station. The 115kV station configuration will be a breaker and a half. The distribution portion of the station will include two 30 MVA transformers, six feeders, and auxiliary feeder positions on each bus.

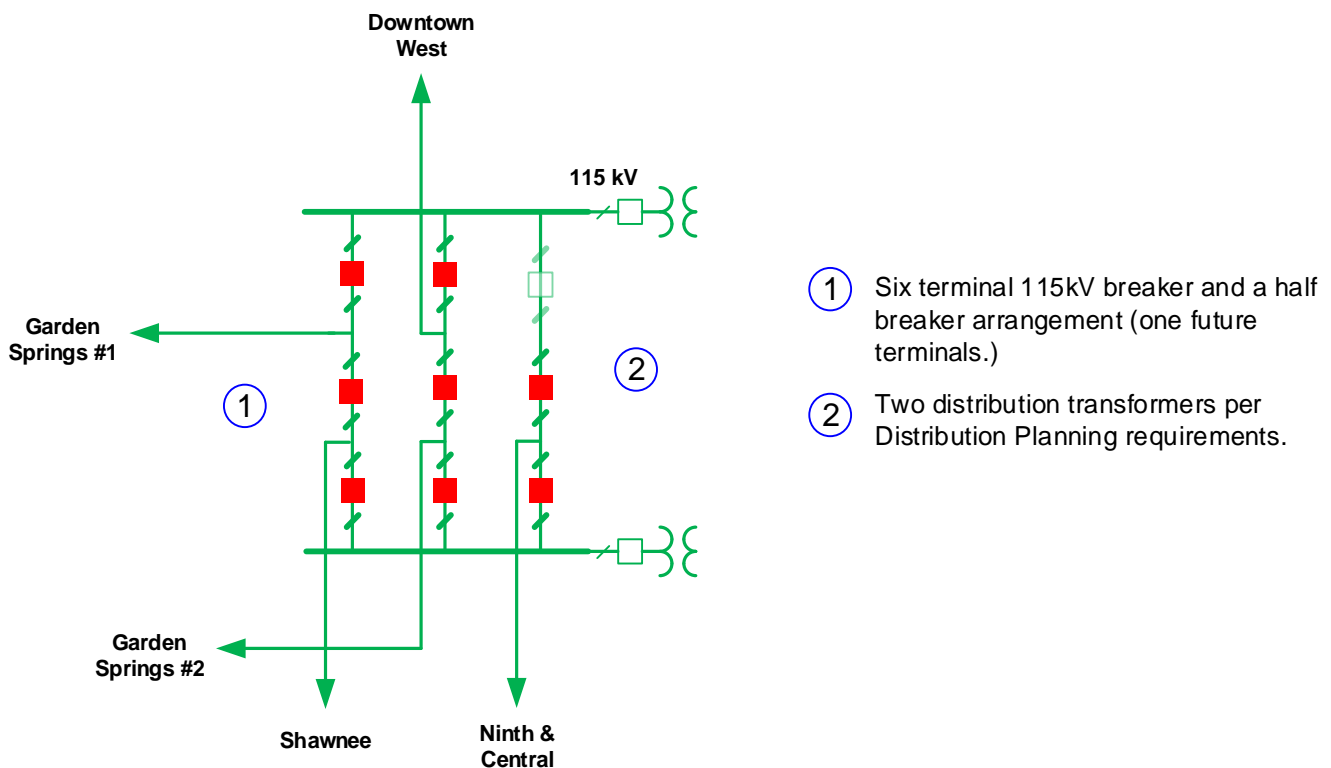

FIGURE 4: SUNSET STATION REBUILD PROJECT DIAGRAM

## 4 WEST PLAINS SYSTEM REINFORCEMENT

The West Plains and Sunset area (up to 245MW) is served by four 115kV transmission lines, which may overload for multiple contingency events during summer loading. Existing mitigation projects (Garden Springs – Sunset 115kV Transmission Line rebuild and the Ninth & Central – Sunset 115kV Transmission Line rebuild) help reduce the amount of overloading, but do not correct known contingency issues.

The West Plains System Reinforcement initiative includes the construction of a new 230kV transmission source into the area. A new transmission line is proposed to connect the Bell – Coulee corridor to a new Garden Springs Station. The Garden Springs Station will include two 250MVA nominal 230/115kV transformers and intersect the Sunset – Westside and Airway Heights – Sunset 115kV transmission lines. Additional reinforcements in the area to support distribution system expansion and interconnect new distribution stations includes a new 115kV transmission line from Airway Heights Station to a new Melville Station which intersects the South Fairchild 115kV transmission line Tap near Hallett & White Station. New distribution stations at Flint Road and Russel Road will increase transformation capacity and provide additional feeders to serve the increased distribution system demands.

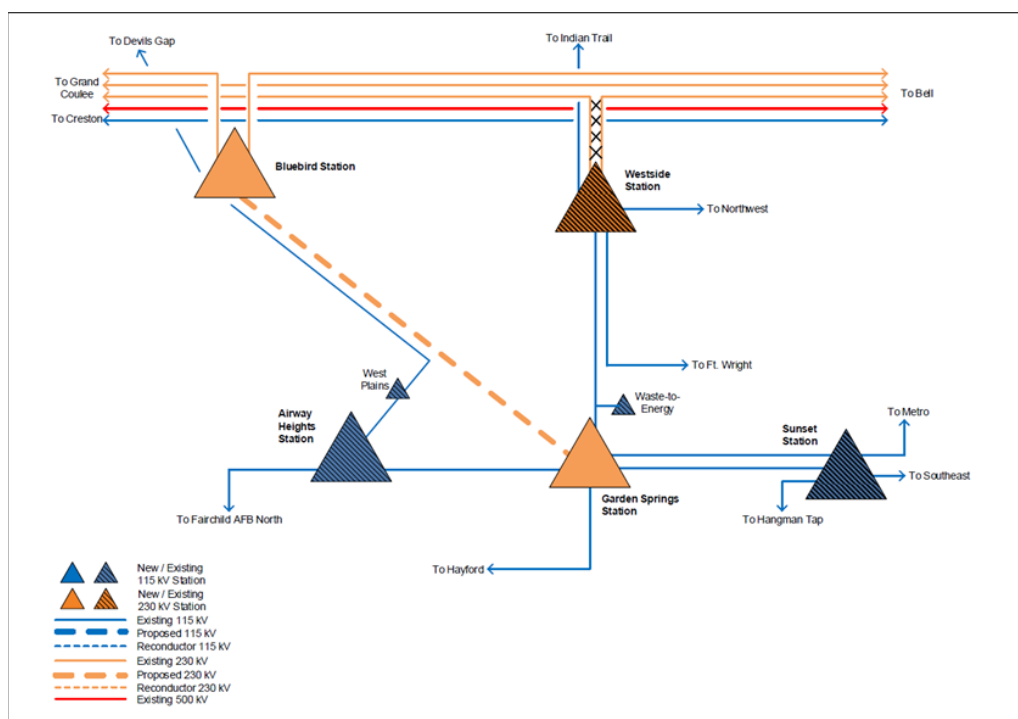

FIGURE 5: GARDEN SPRINGS STATION PROJECT DIAGRAM

## 5 WESTSIDE STATION REBUILD

Outages causing loss of 230/115kV transformers at the BPA Bell or Avista Beacon Station, or outages causing increased impedance from the Bell and/or Beacon Stations to the area's distribution stations cause the Westside #1 and #2 230/115kV transformers to exceed their applicable facility ratings. The Westside Station Rebuild project is a complete station rebuild which includes the replacement of the existing Westside #1 and #2 230/115kV transformers with 250MVA nominal capacity transformers. Both the 230kV and 115kV configuration will be double bus, double breaker.

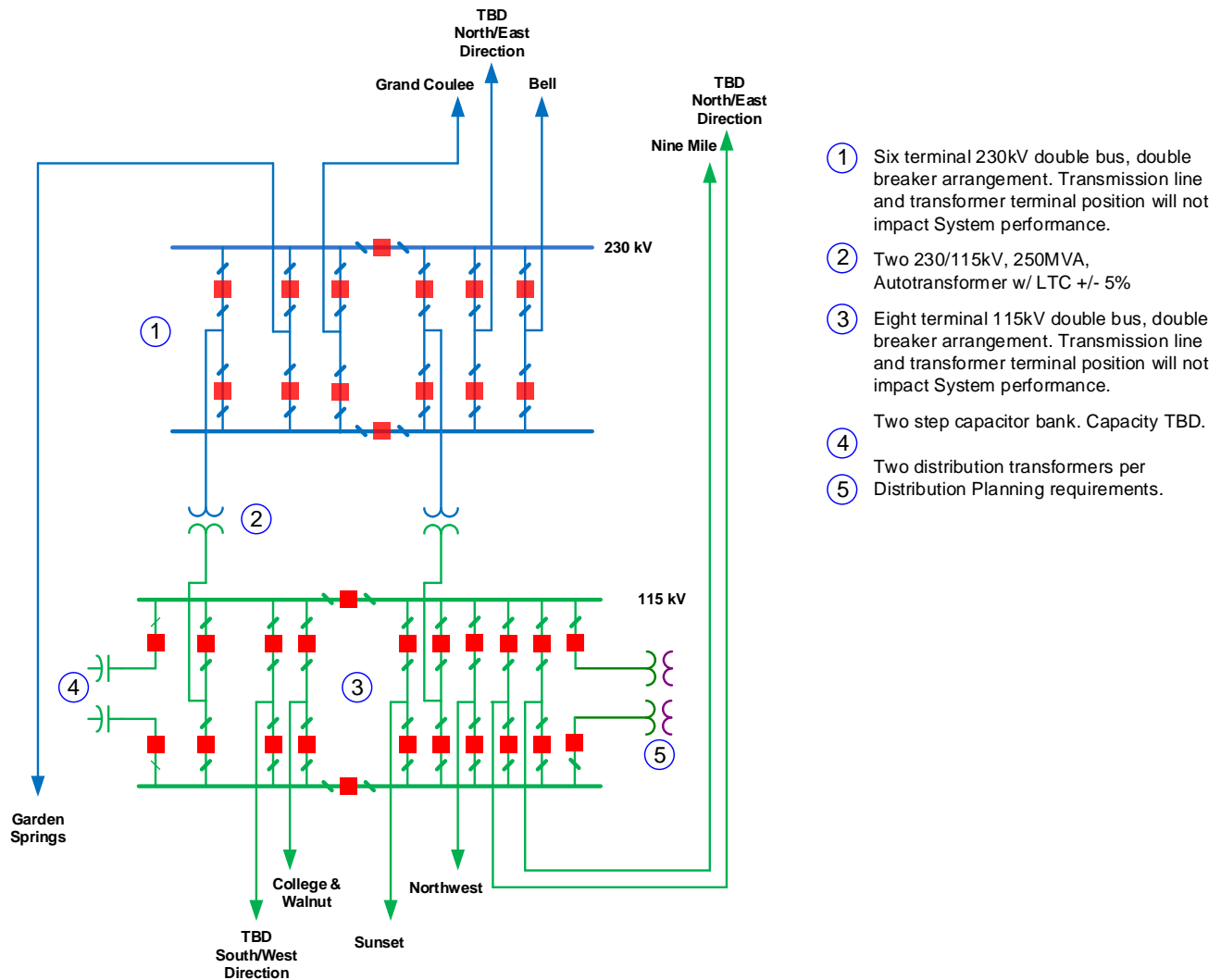

FIGURE 6: WESTSIDE STATION REBUILD PROJECT DIAGRAM



# 2019-2020 Avista System Assessment

## *Electrical System Planning Assessment*



NEILSON SWITCHING STATION – RATTLESNAKE FLAT WIND INTEGRATION

### Version History

Version	Date	Action	Prepared By	Reviewed By
0	11/15/19	Draft posted for stakeholder review	Spratt	Gross
1	12/20/19	Final	Team	Gross
1.1	1/9/20	De minimis	Spacek	Gross
2	12/18/20	2020 Update, confirmed 2019 results	Gross	Spacek

# TABLE OF CONTENTS

<b>I</b>	<b>EXECUTIVE SUMMARY .....</b>	<b>4</b>
<b>II</b>	<b>INTRODUCTION .....</b>	<b>6</b>
<b>III</b>	<b>TECHNICAL STUDY OVERVIEW .....</b>	<b>8</b>
1	ASSUMPTIONS .....	8
2	TECHNICAL STUDIES .....	10
3	POINT OF CONTACT .....	10
<b>IV</b>	<b>PROJECT AND ISSUE LIST .....</b>	<b>11</b>
1	SUMMARY .....	11
2	IDENTIFIED SYSTEM PROJECTS .....	15
3	COMPLETED PROJECTS .....	31
<b>V</b>	<b>TECHNICAL ANALYSIS RESULTS .....</b>	<b>32</b>
1	STEADY STATE CONTINGENCY ANALYSIS .....	32
2	VOLTAGE STABILITY ANALYSIS .....	48
3	STABILITY CONTINGENCY ANALYSIS .....	49
5	SPARE EQUIPMENT ANALYSIS .....	52
6	SHORT CIRCUIT ANALYSIS .....	54
8	FEEDER CAPACITY ANALYSIS .....	55
	<b>APPENDIX A - AVISTA GENERAL INFORMATION .....</b>	<b>56</b>
	<b>APPENDIX B - TRANSMISSION MODELS .....</b>	<b>58</b>
	<b>APPENDIX C - STEADY STATE CONTINGENCY ANALYSIS RESULTS .....</b>	<b>60</b>
	<b>APPENDIX D - SPARE EQUIPMENT ANALYSIS RESULTS .....</b>	<b>134</b>
	<b>APPENDIX E - SHORT CIRCUIT ANALYSIS RESULTS .....</b>	<b>157</b>
	<b>APPENDIX F - STABILITY CONTINGENCY ANALYSIS RESULTS .....</b>	<b>163</b>
	<b>APPENDIX G - VOLTAGE STABILITY ANALYSIS RESULTS .....</b>	<b>189</b>
	<b>APPENDIX H - FEEDER CAPACITY ANALYSIS RESULTS .....</b>	<b>191</b>
	<b>APPENDIX I - STUDY PLAN .....</b>	<b>199</b>

## 2020 Update

Version 2 of the 2019-2020 Planning Assessment is unchanged from Version 1 published in 2019. A companion document has been created, 2020 Avista System Plan, which provides an updated project list with targeted date of operation for each project. The updated project list is also used as an update to the Attachment K Local Planning Report and proposed Single System Projects developed during year one of the biennial process.

Steady state, short circuit, and stability studies performed during 2019 (less than five calendar years old) have been determined to be still relevant as no material changes have occurred to the System represented by the studies.

A comparison of the modeled scenarios used in the 2019 studies to recent WECC approved base cases was performed using PowerWorld Simulator's Difference Case tool. No material changes to the model, neither new, removed, nor modified equipment, were discovered. Projects constructed during 2020 had been modeled and studied in the 2019 studies. The 2020 summer peak (2141 MW) did not exceed the peak summer load of 2319 MW studied in the 2019 studies. The 2019/2020 winter peak (2113 MW) did not exceed the peak winter load of 2444 MW studied in the 2019 studies.

# I EXECUTIVE SUMMARY

Avista completed a comprehensive study to examine the electrical system's reliability under normal operating conditions along with prescribed planning events that include single and multiple outage conditions, commonly referred to as N-1-1. The results of this current study are compared to the benchmark of earlier studies to characterize the system's operational changes over time. Mitigation plans are provided in response to identified functional or operational issues.

Avista's System Planning process is designed to be transparent, open, and understandable, treating all customer classes on an equal and comparable basis. The study plan methodology develops operable solutions for conditions or states that negatively impact system reliability, adequacy, or security. The proposed solutions may include wired and non-wired options that either prevent or resolve the reliability concerns.

The impact of operational contingencies, generally defined as the unexpected failure or outage of an electrical system component, are evaluated by Avista through analysis of seasonal load and generation variations through a multi-year study. Of the contingencies evaluated, none resulted in Instability Cascading or Uncontrolled Separation conditions, confirming there are no Interconnection Reliability Operating Limits that would adversely impact the reliable operation of the Bulk Electric System.

Key findings from these studies include:

- No thermal criteria issues were identified under normal operational conditions regardless of season.
- Minor voltage exceedance issues were identified on the 115kV transmission system when evaluated under light load conditions.
- Heavy summer load conditions continue to drive the most significant system stressors, especially for transmission line and transformer capacities, most of which can be mitigated by upgrades or operational considerations.
- Transformers generally reach capacity limits prior to local transmission line segments.
- Available feeder capacity has been reduced in areas demonstrating load growth requiring several new or upgraded distribution stations.
- A new Corrective Action Plan has been identified to address transient stability issues identified in the Kettle Falls region.
- Three Corrective Action Plans continue to be promoted, specifically:
  - South Spokane system reinforcement
  - Spokane Valley transmission reinforcement
  - Sunset Station rebuild

With respect to projected load growth, thermal-related issues are expected to appear while voltages levels will be reduced, especially on the 115kV system. In addition, utility-scale generation projects may also introduce significant system challenges.

Future planning scenarios will be impacted by proposed generation interconnections and their inherent uncertainty. As with any other system device, interconnection projects will require appropriate mitigation through either the interconnection or transmission service processes to ensure that the existing transmission system performance is not negatively impacted.

## II INTRODUCTION

The 2019-2020 Avista System Assessment (Planning Assessment) is a deliverable from Phase 2 of a two-year process as defined in Avista's Open Access Transmission Tariff (OATT) Attachment K. The Planning Assessment identifies the Transmission System facility additions required to reliably interconnect forecasted generation resources, serve the forecasted loads of Avista's Network Customers and Native Load Customers, and meet all other Transmission Service and non-OATT transmission service requirements, including rollover rights, over a ten-year planning horizon. The Planning Assessment process is open to all Interested Stakeholders, including, but not limited to, Transmission Customers, Interconnection Customers, and state authorities. The Western Electric Coordinating Council (WECC) facilitates interconnection wide planning and development of wide-area planning proposals.

The two-year planning process desired timeline is illustrated in Figure 1. The completion of Phase 2 includes providing the documented results of performing necessary technical studies. The state of the existing and future system is provided. Where the technical studies identified performance issues, conceptual projects have been proposed. Projects identified from previously posted planning assessments are listed as committed projects.

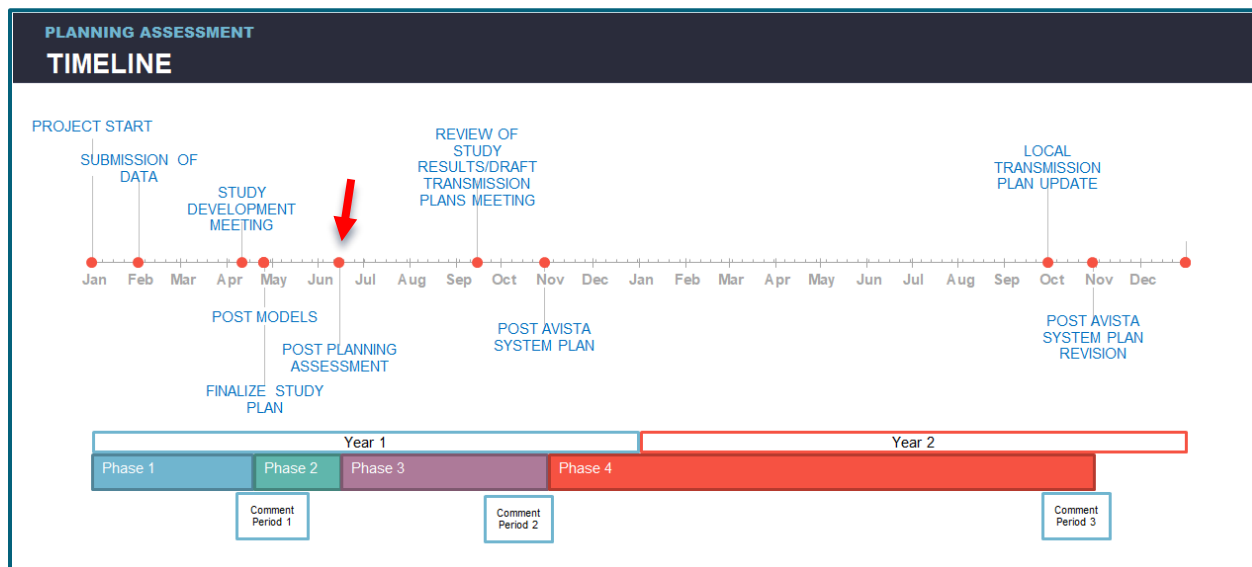

FIGURE 1: PLANNING ASSESSMENT TIMELINE.

Phase 3 of the process will follow the completion of the Planning Assessment. Phase 3 includes providing the Avista System Plan report to stakeholders. The Avista System Plan will include documentation of the electrical infrastructure plan with preferred solution options. The

resulting project list will include additional information regarding projects and system modifications developed through means other than the technical studies<sup>1</sup>.

---

<sup>1</sup> Such other means may include, for example, generation interconnection or transmission service request study processes under the OATT, or joint study team processes under NorthernGrid.

# III TECHNICAL STUDY OVERVIEW

The Avista System Planning Assessment 2019 Study Plan outlines the process, assumptions and technical studies used in the development of the Planning Assessment. The following is a summary of the assumptions and technical studies performed. The complete Study Plan is provided in Appendix I.

## 1 ASSUMPTIONS

### 1.1 System Representation

Computer simulation models are developed to represent the electric transmission and distribution system.

The transmission system models (Planning Cases or base cases) represent Avista's Transmission Planner and Planning Coordinator areas as well as the regional Transmission System. The Planning Case development process outlined in the internal document TP-SPP-04 – Data Preparation for Steady State and Dynamic Studies outlines the use of WECC approved base cases and the modification of steady state and dynamic data as required to represent existing facilities for the desired scenario. The resulting Planning Cases represent a normal system condition (P0). All established pre-contingency operating procedures are represented. Manual application of each operating procedure is followed in the process of developing each Planning Case.

Technical studies performed for the distribution system did not use detailed system models. When distribution system models are used they are created by extracting data from several internal Avista sources.

All technical studies are performed assuming no projects are constructed within the planning horizon. After establishing a list of system deficiencies, new planned facilities and changes to existing facilities are represented to evaluate the impact to the deficiencies. Only potential generation projects in Avista's queue of generation interconnection requests that have executed an Interconnection Agreement are modeled, along with corresponding upgrades, in the models for technical studies.



## 1.2 Load Growth

Avista’s Balancing Authority Area (BAA) load peaked around 2,379MW in the winter of 2017 and 2,239MW in the summer of 2018. Figure 2 shows the BAA load historical seasonal peaks from 2008-2019 and the forecasted seasonal peaks for 2020-2030. The power factor of typical loads at a station vary from 0.95 in the summer to unity in the winter. During light load conditions, some loads may have leading power factor.

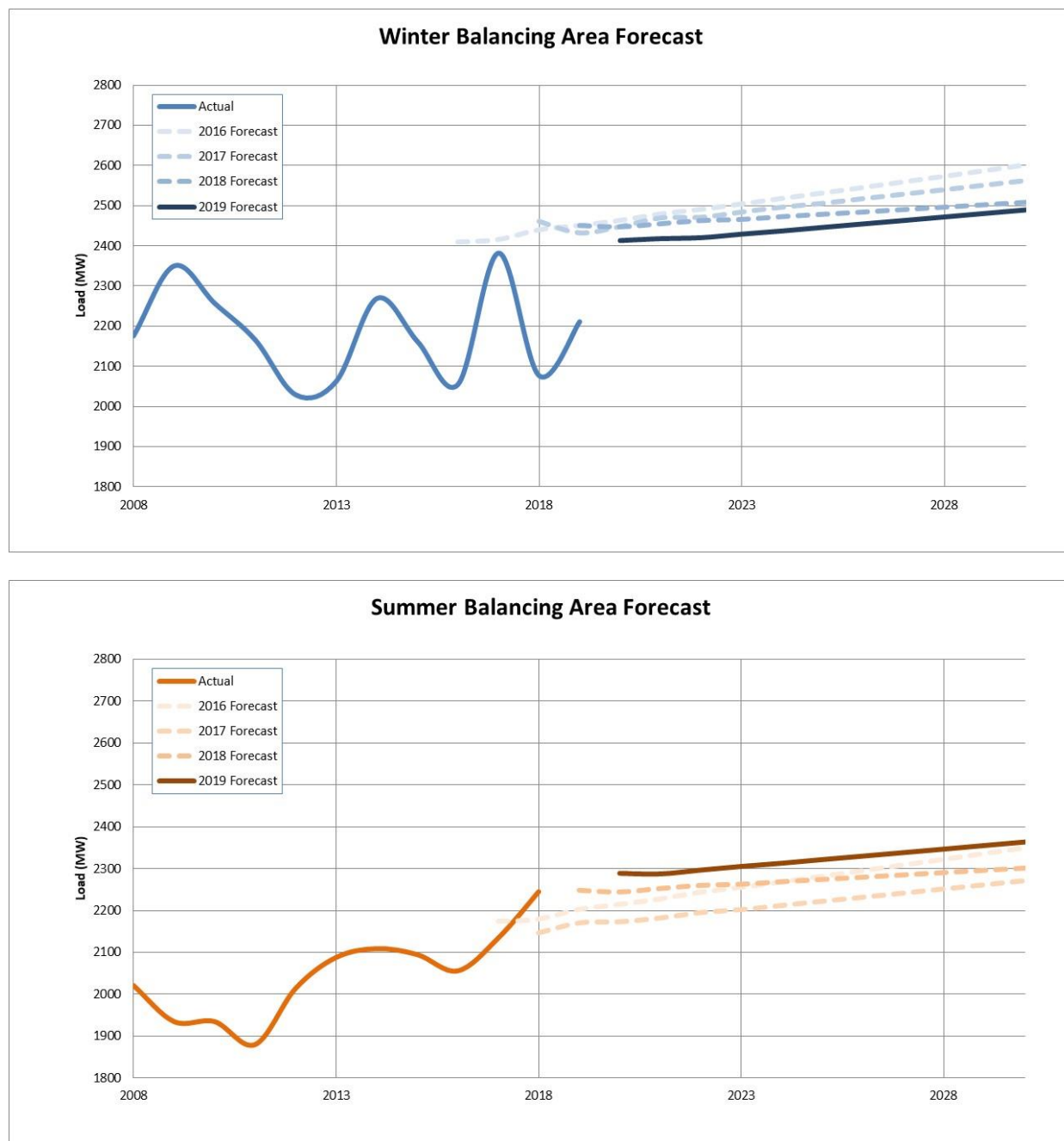

FIGURE 2: ACTUAL AND FORECASTED PEAK BALANCING AUTHORITY AREA LOAD.

### 1.3 Performance Criteria

The criteria used in evaluating the performance of the Transmission System are the current NERC Reliability Standards, WECC regional criterion and internal Avista policies, including the following. A summary of the Transmission System performance criteria is provided in the Study Plan.

- TPL-001-WECC-CRT-3 – Transmission System Planning Performance
- TPL-001-4 – Transmission System Planning Performance Requirements
- FAC-010 – System Operating Limit Methodology for the Planning Horizon
- TP-SPP-01 – Avista Bulk Power System Planning Standards

Distribution system performance criteria is under development.

## 2 TECHNICAL STUDIES

The technical studies performed as part of the Planning Assessment includes the following:

- Steady state contingency analysis
- Spare equipment analysis
- Short circuit analysis
- Stability contingency analysis
- Voltage stability analysis
- Distribution capacity analysis

## 3 POINT OF CONTACT

A Point of Contact for questions regarding this Planning Assessment and the projects described within it has been designated. Please contact the party named below with any questions:

System Planning Department  
PO Box 3727, MSC-16  
Spokane, WA 99220  
TransmissionPlanning@avistacorp.com

# IV PROJECT AND ISSUE LIST

## 1 SUMMARY

The following section provides a list of Single System Projects. Single System Projects are defined as projects necessary to ensure the reliability of the System and to otherwise meet the needs of long-term firm transmission service and native load obligations in accordance with Avista's planning standards. Justification for each project listed can include condition based asset management, necessary to meet performance requirements, customer growth, and others. A summary of the Single System Projects is provided in Table 1. The cost estimate and schedule of each project is subject to change.

The listed Single System Projects justified as necessary to meet performance requirements categorized as Corrective Action Plans are also noted in Table 1. Corrective Action Plans address how performance requirements will be met where the technical studies have indicated an inability of the System to meet the performance requirements of TPL-001. Corrective Action Plans are specific projects developed to meet the criteria defined by NERC (TPL-001-4 R2.7.3).

All Single System Projects are subject to change or modification as necessary to accommodate changes in load, generation, or other unforeseen system conditions.

TABLE 1: AVISTA TEN YEAR PROJECT LIST SUMMARY

Proposed Initiative	Existing Business Case	#	Project Name	Issue Mitigated	Date of Operation
Big Bend System Reinforcement	SDSC	47	Bruce Siding 115-13kV Sub	Distribution Capacity	
	SDSR	11	Davenport 115-13kV Sub	Age, condition and SCADA	2021
		30	Little Falls 115kV	Age and condition	2022
		86	Sprague 115kV Substation - Minor Rebuild	Age and condition	
	TCC	6	Benton-Othello 115kV Line	Sand Dunes 115kV bus outage	2020
		50	Chelan-Stratford 115kV Line	To be determined	
	TMR-AC	53	Devils Gap-Lind 115kV Line	Age and condition	
Cabinet Gorge GSU Isolation	PS	17	Cabinet Gorge 230kV Switchyard	Unnecessary bus clearing	2021
Coeur d'Alene System Reinforcement	SDSC	48	Canfield 115-13kV Sub	Distribution Capacity	
		7	Dalton 115-13kV Sub - Add 30MVA XFM	Distribution Capacity	2020
		75	Pleasantview 115-13kV	Distribution Capacity	
		81	Rathdrum Distribution	Distribution Capacity	
	SDSR	22	Huetter 115-13kV Sub - Expand Sub	Distribution Capacity	
		82	Rathdrum 230/115kV Station	Contingency	2024
	TCC	1	Coeur d'Alene-Pine Creek 115kV Line	Contingency and capacity	2019

# Planning Assessment | 2019-2020

Proposed Initiative	Existing Business Case	#	Project Name	Issue Mitigated	Date of Operation
East Coeur d'Alene Lake System Reinforcement	SDSC	27	Carlin Bay 115kV Sub	Distribution Capacity	2023
		10	St. Maries 115-24kV	Distribution capacity and reliability	
	SDSR	27	O'Gara 115kV Switching Station	Distribution Capacity	2023
	TMR-AC	45	Benewah-Pine Creek 230kV	Age and condition	
	TNC	27	Carlin Bay-O'Gara 115kV Line	Distribution Capacity	2023
Idaho/Lewis County System Reinforcement	SDSR	60	Grangeville 115-13-34.5kV	Age and condition	2023
		65	Kooskia 115/13kV	Age and condition	2023
Kettle Falls Stability		<b>91</b>	<b>Addy - Kettle Falls Protection Scheme<sup>2</sup></b>	<b>Kettle Falls OOS</b>	
Lewiston/Clarkston System Reinforcement	PS	61	Hatwai-Lolo #2 230kV Line	Contingency and capacity	2024
	SDSC	28	Lewiston Orchards Irrigation District 115-13kV Sub	Customer requested	2021
		90	Wheatland 115-13V Sub	Distribution Capacity	
	SDSR	36	Tenth & Stewart 115-13kV	Distribution Capacity	
		19	Bryden Canyon 115kV Sub (Replace Equip)	Load service and reliability	2022
		56	Dry Gulch	Customer requested	2020
		21	Lolo 230kV Station	Age, condition and capacity	2023
		78	Pound Lane 115-13kV	Age and condition	
	TMR-AC	66	Lolo-Oxbow 230kV Line	Age and condition	2025
Metro Station Rebuild	SDSR	20	Metro 115-13V Sub	Age and condition	2023
	TMR-AC	5	Metro-Post Street 115kV Line	Age and condition	2020
		76	Post Street-Third & Hatch 115kV Line	Age and condition	2021
North Spokane System Reinforcement	PS	42	Beacon-Bell-F&C-Waikiki Reconfiguration	Contingency and capacity	
		69	Mead-Colbert-Milan 115kV Line	Contingency and capacity	
	SDSC	33	Florida & Dalke 115-13kV Sub	Distribution Capacity	2024
		23	Hawthorne 115kV Sub	Contingency and capacity	2024
		26	Midway 115/13kV Sub	Distribution Capacity	2023
		88	Waikiki - Add Capacity	Distribution Capacity	2021
		89	Waikiki-Mead 115/13kV Sub	Distribution Capacity	2023
	SDSR	67	Lyons & Standard 115-13kV	Distribution Capacity	
		35	Northwest 115-13kV Sub	Age and condition	2021
	TNC	33	Transmission to Serve Hillyard Sub	Distribution capacity	
		23	Transmission to Serve Hawthorne Sub	Distribution capacity	
	62	Indian Trail-Waikiki 115kV Line	Contingency and capacity		
	69	Mead-Colbert-Milan 115kV Line	Contingency and capacity	2024	

<sup>2</sup> Corrective Action Plan

# Planning Assessment | 2019-2020

Proposed Initiative	Existing Business Case	#	Project Name	Issue Mitigated	Date of Operation
Palouse System Reinforcement	SDSC	49	Center Street 115-13V Sub	Distribution Capacity	2023
		29	M/P State Line 115-13V Sub	Distribution Capacity	
		87	Tamarack 115/13kV Sub	Distribution Capacity	
	SDSR	71	Moscow City 115kV Sub	Age and condition	
		72	N. Moscow 115kV Station: Add Transformer	Distribution Capacity	
		74	Palouse Transformation: Add Auto at Moscow or Shawnee	Contingency	
		77	Potlatch 115/13kV	Age and condition	
Protection System Upgrade for PRC-002	PS	79	PRC-002 Protection System Upgrade	Compliance	2022
Rattlesnake Flat Wind Farm	PS	2	Rattlesnake Flat 115kV Wind Farm Project	Customer requested	2020
Saddle Mountain Integration	PS	9	Saddle Mountain 230/115kV Sub (Phase 1)	Contingency and capacity	2020
		13	Saddle Mountain 230/115kV Sub (Phase 2)	Contingency and capacity	2021
Sandpoint System Reinforcement	SDSR	32	Bronx 115/21kV Substation	Distribution Capacity	2024
	TCC	83	RAT-SPI or ALB-SPI 115kV Line	Contingency	2024
Silver Valley System Reinforcement	SDSC	70	Mission 115kV Sub	Age and condition	
	SDSR	46	Big Creek 115kV Sub	Age and condition	
	TMR-AC	73	Noxon-Pine Creek 230kV	Age and condition	2022
South Spokane System Reinforcement	PS	42	Beacon 230kV Sub	Contingency and capacity	
		85	<b>Spokane West of Beacon - New 230kV Transformation<sup>3</sup></b>	<b>Contingency and capacity</b>	<b>2025</b>
	SDSC	54	Downtown East 115-13kV Sub	Distribution Capacity	
		55	Downtown West 115-13kV Sub	Distribution Capacity	2023
	SDSR	4	Southeast 115-13kV	Distribution Capacity	2019
		52	College & Walnut 115kV Sub	Age and condition	
		84	Ross Park 115kV Sub	Age and condition	
		TCC	39	9CE-Sunset 115kV Line	Contingency and capacity
TCC	44	Beacon-Ross Park 115kV Line	Age and condition	2020	
Spokane Valley Transmission Reinforcement	SDSC	63	Irvin 115/13kV Sub	Distribution Capacity	2021
	SDSR	41	Barker 115/13kV Substation	Distribution Capacity	
		51	Chester 115-13kV Sub	Age and condition	
	SVTR	14	BEA-BLD #2 115 - Upgrade 314MVA (TLD4)	Line section outage issues, motor starting support at IEP and reliability	2021

<sup>3</sup> Corrective Action Plan

Proposed Initiative	Existing Business Case	#	Project Name	Issue Mitigated	Date of Operation
		<b>12</b>	<b>Irvin 115kV Switching Station<sup>4</sup></b>	<b>Contingency and capacity</b>	<b>2021</b>
	TCC	43	Beacon-Boulder #1 115kV Line	Contingency and capacity	2021
Stevens/Ferry County System Reinforcement	SDSC	37	49 Degrees North 115kV Sub	Distribution Capacity	
		34	Valley 115kV Sub	Age and condition	2022
	TCC	40	Addy-Devils Gap 115kV Line	Contingency and capacity	2020
Sunset Station Rebuild	<b>SDSR</b>	<b>15</b>	<b>Sunset 115kV Sub<sup>5</sup></b>	<b>Age, condition and reliability</b>	<b>2021</b>
West Plains System Reinforcement	PS	58	Garden Springs 115/13kV Substation	Contingency and capacity	2023
		59	Garden Springs 230kV Substation	Contingency and capacity	
	SDSC	16	Flint Road 115/13kV Sub	Distribution Capacity	2022
		18	Four Lakes - Add Cap Bank	P6 low voltage	
		68	McFarlane 115/13kV Sub	Distribution Capacity	
	TBD	31	Melville Switching Station	Customer requested, contingency	
Westside Station Rebuild	PS	8	Westside 230/115kV Sub (Phase 1-4)	Contingency and capacity	2022

<sup>4</sup> Corrective Action Plan

<sup>5</sup> Corrective Action Plan

## 2 IDENTIFIED SYSTEM PROJECTS

Following is a summary of identified system issues, mitigations considered and recommendations.

### 2.1 Big Bend System Reinforcement

The Davenport, Little Falls and Sprague stations in the Big Bend area have been identified as a concern due to age and condition. Additionally, the age and condition of the Devil's Gap – Lind 115kV Transmission Line has been identified as a concern due to age and condition.

The Chelan – Stratford 115kV Transmission Line has demonstrated overload conditions due to local hydro generation during contingencies scenarios. The transmission line segments overloaded are 0.38 miles of 19#8 CW and 33.89 miles of 250 CU conductor with a rating of 78.3 MVA at 40°C.

#### Mitigation considered

The condition of identified stations and transmission lines due to age and condition should be analyzed to determine the scope of rebuilding the assets or target specific equipment replacement.

#### Recommendations

- Rebuild Davenport, Little Falls, and Sprague stations.
- Minor rebuild of Devils Gap – Lind 115kV Transmission Line.
- Utilize operating procedure to reduce local hydro generation for contingencies impacting Chelan – Stratford 115kV Transmission Line.

### 2.2 Cabinet Gorge GSU Isolation

The design to integrate the Cabinet Gorge hydro facility into the 230kV Western Montana Hydro transmission system did not include 230kV breakers to isolate the generation from the transmission system. This resulted in one zone of protection encapsulating both the Generator Step-Up (GSU) transformers and the 230kV bus. The deficiency with this design is that it is not selective enough and drops all 230kV lines, the Cabinet 230/115kV autotransformer and all Cabinet Gorge generation for issues with the either GSU.

Studies have identified the following contingency issue:

- Loss of a single Cabinet Gorge GSU (P1.3) results in the loss of up to 240MW of generation, two 230kV lines, and a 230/115kV autotransformer.

#### Mitigation considered

- Full rebuild of Cabinet Substation.
- Modify the existing Cabinet Substation with the addition of high-side GSU circuit breakers.

- Building a new switching station west of the existing Cabinet Substation to incorporate breakers and loop in the Lancaster – Noxon 230kV Transmission Line.

### Recommendations

- A reliability upgrade to Cabinet substation consisting of a new 230kV breaker for each GSU, relocating two termination towers and adding new 230kV bus. Upgrades will require updates to GSU and bus relay protection.

## 2.3 Coeur d'Alene System Reinforcement

The Coeur d'Alene area is served by two 230/115kV autotransformers and a single 115kV transmission line. The Coeur d'Alene area is connected by one additional 115kV transmission line that has historically been operated normally open. The autotransformers along with the 115kV transmission lines feeding Coeur d'Alene load may overload for multiple contingency events during moderate to heavy loading during all seasons.

Studies have identified the following contingency issues:

- Loss of the Rathdrum 115kV east bus (P2.2) or a breaker failure on the Rathdrum 115kV east bus (P2.3) may result in an overload of a 115kV transmission line.
- Loss of the Pine Street – Rathdrum 115kV Transmission Line followed by the loss of a 230/115kV autotransformer (P6) may result in an overloaded 230/115kV autotransformer.
- Loss of a Rathdrum 230/115kV autotransformer followed by the loss of a 230/115kV autotransformer (P6) may result in voltage collapse in the Coeur d'Alene area. This results in the loss of up to 140MW of generation and 275MW of load.
- A Rathdrum 115kV bus tie breaker failure during any season results in the loss of up to 140MW of generation and 275MW of load in the Coeur d'Alene area.

Load growth in the Coeur d'Alene area has contributed to heavy loaded distribution facilities. The following stations have feeders which have exceeded 80% of their applicable facility ratings: Appleway, Dalton, Huetter, Post Falls, Prairie and Idaho Road. Anticipated load growth will increase the feeder loading and reduce necessary operational capacity.

The Prairie Station in the Coeur d'Alene area has been identified as a concern due to age and condition.

### Mitigation considered

Transmission system contingency issue mitigation alternatives include the following:

- Operate the Coeur d'Alene – Pine Creek 115kV Transmission Line normally closed and revert back to the original 115kV transmission line configuration between Coeur d'Alene and Spokane Valley.
  - Requires upgrading the transmission lines connecting Coeur d'Alene and Spokane Valley.



- Operate the Coeur d'Alene – Pine Creek 115kV Transmission Line normally closed and build a new switching station near the crossing of Chase Road and Poleline Avenue.
- Build a new 230/115kV substation between Boulder Substation and Rathdrum Substation and integrate the existing 115kV transmission lines into this new substation.
- Build a new 230/115kV substation southeast of Coeur d'Alene with a 230kV tie to Pine Creek and integrate the existing 115kV transmission lines into the new substation.

Upgrade existing distribution stations with additional feeder capacity including: Dalton, Pleasantview, Rathdrum, Huetter, and Prairie.

The condition of identified stations due to age and condition should be analyzed to determine the scope of rebuilding the assets or target specific equipment replacement.

### Recommendations

- The transmission system contingency mitigation project's specific scope and impact will be evaluated by the responsible parties within Avista to assist in the development of a coordinated business and implementation plan that will be presented to the Engineering Roundtable (ERT) for approval, prioritization, and deployment.
- Rebuild Pleasantview and Prairie stations.

## 2.4 East Coeur d'Alene Lake System Reinforcement

Forecasted load growth along the east side of Coeur d'Alene Lake is expected to cause the total load to exceed the capability of the existing 13.2 kV distribution system in the area. Feeder protection coordination and voltage regulation are not able to meet necessary performance requirements. Cold load pickup will cause protection devices to function during moderate to heavy loading levels.

Feeder loading from the St. Maries Station are near capacity. Recent growth in the area including a large industrial customer with 2300 horsepower of motor load will further increase equipment loading and reduce operational flexibility to maintain and back up feeders. The lack of Supervisory Control and Data Acquisition (SCADA) at St. Maries Station creates safety concerns and does not allow necessary situational awareness of the equipment status.

The Benewah – Pine Creek 230kV Transmission Line has been identified as a concern due to age and condition.

### Mitigation considered

- Construct new Carlin Bay Station with a 13 mile radial 115kV transmission line to a rebuilt O'Gara Station.
- Convert area distribution system to 25kV.
- Upgrade St. Maries Station with fourth feeder and addition of SCADA.
- Rebuild the Benewah – Pine Creek 230kV Transmission Line

### Recommendations

- Construct new Carlin Bay Station with a 13 mile radial 115kV transmission line to a rebuilt O’Gara Station.
- Upgrade St. Maries Station with fourth feeder and addition of SCADA.

## 2.5 Idaho/Lewis County System Reinforcement

The Grangeville and Kooskia stations in the Idaho/Lewis county area have been identified as a concern due to age and condition.

### Mitigation considered

The condition of identified stations due to age and condition should be analyzed to determine the scope of rebuilding the assets or target specific equipment replacement.

### Recommendations

- Rebuild Grangeville and Kooskia stations

## 2.6 Kettle Falls Stability

Implementation of a high speed, communication aided tripping scheme on the Addy – Kettle Falls 115kV Transmission Line is necessary to improve stability performance of the Kettle Falls generation facility. Stability contingency analysis indicates an inability of the System to meet the performance requirements in requirement R4.1.1 of TPL-001-4.

Studies have identified the following contingency issue:

- The Kettle Falls generator can become unstable if a time delayed three phase fault occurs on the Addy – Kettle Falls 115kV Transmission Line near Addy.

### Mitigation considered

- This is a vetted project. Refer to past studies for mitigation options.

### Recommendations

- The identified contingency issues will require a Corrective Action Plan.
- Modification of the Addy – Kettle Falls 115kV Transmission Line Protection System to include a communication aided protection scheme. A new communication path is required between Addy and Kettle Falls stations. Upgrades and setting changes to relays at BPA’s Addy Substation and Avista’s Kettle Falls Substation are also required to implement Avista’s standard communication aided protection schemes.

## 2.7 Lewiston/Clarkston System Reinforcement

The existing 230kV system and underlying 115kV lines in the Lewiston/Clarkston area may overload during summer loading and high transfers south on the Idaho – Northwest (Path 14) cut plane for multiple contingency events. Planned or forced 230kV outages in the Lewiston/Clarkston area require a radial configuration of the 115kV system, arming RAS and/or reducing transfers on the Idaho – Northwest or West of Hatwai cut planes.

Studies have identified the following contingency issues:

- Loss of Dry Creek – North Lewiston 230kV Transmission Line followed by the loss of a 230kV transmission line (P6) may result in an overload of multiple 115kV transmission lines.
- Loss of Hatwai – Lolo 230kV Transmission Line followed by the loss of a 230/115kV autotransformer or any of two 230kV transmission lines (P6) may result in an overload of multiple 115kV transmission lines.
- Loss of the North Lewiston 230/115 #1 Transformer followed by the loss of a 230kV transmission line (P6) may result in an overloaded 115kV transmission line.

Load growth in the Lewiston/Clarkston area has contributed to heavy loaded distribution facilities. The following stations have feeders which have exceeded 80% of their applicable facility ratings: Lolo, Critchfield, and Tenth & Stewart. Anticipated load growth will increase the feeder loading and reduce necessary operational capacity.

The South Lewiston, Lolo and Pound Lane stations in the Lewiston/Clarkston area have been identified as a concern due to age and condition. Additionally, the age and condition of the Lolo – Oxbow 230kV Transmission Line has been identified as a concern due to age and condition.

## Mitigation considered

Transmission system contingency issue mitigation alternatives include the following:

- Rebuild the overloaded 115kV transmission lines that were identified in the study.
- Rebuild South Lewiston substation into a switching station and close all three lines into the new station.
  - Reduces contingency overloads, but does not correct overload issues.
- Build a new second Hatwai – Lolo 230kV transmission line to either connect into Lolo Substation or bypass the Lolo Substation and connect directly to Oxbow Substation. This may require a new transmission line terminal at Lolo Station and a request for interconnection at BPA's Hatwai Station.

Rebuild existing distribution stations with additional feeder capacity.

The condition of identified stations due to age and condition should be analyzed to determine the scope of rebuilding the assets or target specific equipment replacement.

## Recommendations

- The transmission system contingency mitigation project's specific scope and impact will be evaluated by the responsible parties within Avista to assist in the development of a coordinated business and implementation plan that will be presented to the Engineering Roundtable (ERT) for approval, prioritization, and deployment.

- Rebuild Tenth & Stewart and Pound Lane stations and targeted equipment replacement at Lolo Station.
- Construct new Bryden Canyon and Wheatland stations.
- Rebuild portions of the Lolo – Oxbow 230kV Transmission Line and evaluate priorities of other 230kV transmission line rebuilds.

## 2.8 Metro Station Rebuild

Metro Station dates to the mid-1970s. Switchgear is the worst condition on the system. Much of the major equipment in this station is now unsupported by the manufacturer. Legacy oil tanks beneath the site pose an environmental problem and limit modifications to upgrade the existing station. Underground transmission cables to this site are in need of replacement. Transformer/switchgear spares are unavailable/difficult to install in an outage scenario. Various other condition issues, such as the 115kV breakers, insulators, and panel house, also exist at this site.

Additionally, the age and condition of the Metro – Post Street and Post Street – Third & Hatch 115kV transmission lines has been identified as a concern due to age and condition.

### Mitigation considered

- Rebuild Metro Station by replacing existing equipment with new.
- Rebuild Metro Station with new equipment in an improved configuration.
- Construct a new station on a new site to replace the existing Metro Station.
- Replace existing transmission cable on the Metro – Post Street and Post Street – Third & Hatch 115kV transmission lines.

### Recommendations

- Construct a new station on a new site to replace the existing Metro Station.
- Replace existing transmission cable on the Metro – Post Street and Post Street – Third & Hatch 115kV transmission lines.

## 2.9 North Spokane System Reinforcement

Avista's Beacon and BPA's Bell substations are connected by two 115kV lines, either of which may overload for multiple contingency events during moderate to heavy loading during all seasons. Note that the additional autotransformer capacity, which is planned for the South Spokane area, will increase the overloads identified in these results.

Studies have identified the following contingency issues:

- A Beacon 115kV bus tie breaker fault (P2.4) may result in an overload of multiple 115kV transmission lines.
- Loss of the Beacon – Bell 115kV Transmission Line followed by the loss a 230/115kV autotransformer (P6) may result in an overload of multiple 115kV transmission lines.

- Loss of the Beacon – Northeast 115kV Transmission Line followed by the loss a 230/115kV autotransformer (P6) may result in an overloaded 115kV transmission line.
- Loss of the Bell 230/115kV #6 Transformer followed by the loss of any of two 115kV transmission lines (P6) may result in an overloaded 115kV transmission line.
- Loss of the Bell – Northeast 115kV Transmission Line followed by the loss a 230/115kV autotransformer (P6) may result in an overloaded 115kV transmission line.
- Loss of the Francis & Cedar – Ross Park 115kV Transmission Line followed by the loss of a 115kV transmission line (P6) may result in an overloaded 115kV transmission line.

Load growth in the North Spokane area has contributed to heavy loaded distribution facilities. The following stations have feeders which have exceeded 80% of their applicable facility ratings: Colbert, Francis & Cedar, Waikiki and Mead. Anticipated load growth will increase the feeder loading and reduce necessary operational capacity.

The Northwest Station in the North Spokane area has been identified as a concern due to age and condition.

### Mitigation considered

Transmission system contingency issue mitigation alternatives include the following:

- Rebuild the overloaded 115kV transmission lines that were identified in the study.
  - This requires the rebuild of the Beacon – Bell, Beacon – Northeast, Bell – Northeast, and Beacon – Francis & Cedar 115kV transmission lines.
- Add Remedial Action Scheme (RAS) to drop load in the BPA area.
  - Solution only solves BPA related issues, but does not correct remaining Avista related transmission line loading issues.
- Build a new 115kV transmission line from Indian Trail substation to Waikiki substation and add breaker positions to both stations.
  - Does not correct all identified 115kV transmission line overloads.
- Loop the Beacon – Francis & Cedar 115kV transmission line into Bell.

Rebuild existing distribution stations with additional feeder capacity and construct new distribution stations.

The condition of identified stations due to age and condition should be analyzed to determine the scope of rebuilding the assets or target specific equipment replacement.

### Recommendations

- The transmission system contingency mitigation project's specific scope and impact will be evaluated by the responsible parties within Avista to assist in the development of a coordinated business and implementation plan that will be presented to the Engineering Roundtable (ERT) for approval, prioritization, and deployment.

- Rebuild Northwest Station.
- Construct new Florida & Dalke, Hawthorne and Midway stations.
- Construct new 115kV infrastructure to the north of Spokane to interconnect Avista distribution stations into Avista's transmission system.

## 2.10 Palouse System Reinforcement

The Palouse area is served by two 230/115kV autotransformers and a single 115kV line. The Palouse is connected by four additional 115kV transmission lines that have historically been operated normally open. These autotransformers along with the 115kV transmission lines feeding Palouse load may overload for multiple contingency events during moderate to heavy loading (all seasons).

Studies have identified the following contingency issues:

- Loss of a Palouse area 230/115kV autotransformer followed by the loss of a 230/115kV autotransformer (P6) may result in voltage collapse in the Palouse area. This results in the loss of up to 186MW of load.
- Loss of the Moscow – South Pullman 115kV Transmission Line followed by the loss a 230/115kV autotransformer (P6) may result in an overloaded 115kV transmission line.
- Loss of the Moscow – Terre View 115kV Transmission Line followed by the loss a 230/115kV autotransformer (P6) may result in an overloaded 115kV transmission line.

Load growth in the Palouse area has contributed to heavy loaded distribution facilities. The following stations have feeders which have exceeded 80% of their applicable facility ratings: Turner. Anticipated load growth will increase the feeder loading and reduce necessary operational capacity.

The Moscow City and Potlatch stations in the Palouse area have been identified as a concern due to age and condition.

### Mitigation considered

Transmission system contingency issue mitigation alternatives include the following:

- Add a new position at Moscow and extend the Moscow City – North Lewiston 115kV Transmission Line into Moscow 230 Station. Operate with Moscow City normally fed from this line, with the auto-throwover to the Moscow – South Pullman 115kV Transmission Line.
- Add a second 230/115kV autotransformer at Moscow or Shawnee stations.
- Build a new 230/115kV station east of Pullman and integrate the existing 115kV transmission lines into the new station.

Construct new and rebuild existing distribution stations with additional feeder capacity.

The condition of identified stations due to age and condition should be analyzed to determine the scope of rebuilding the assets or target specific equipment replacement.

### Recommendations

- The transmission system contingency mitigation project's specific scope and impact will be evaluated by the responsible parties within Avista to assist in the development of a coordinated business and implementation plan that will be presented to the Engineering Roundtable (ERT) for approval, prioritization, and deployment.
- Construct new Center Street, State Line and Tamarack stations.
- Rebuild Moscow City and Potlatch stations.

## 2.11 Protection System Upgrade for PRC-002

NERC reliability standard PRC-002-2 defines the disturbance monitoring and reporting requirements to have adequate data available to facilitate analysis of Bulk Electric System (BES) Disturbances. The methodology of Attachment A of the NERC standard was performed to identify the affected buses within the Avista BES. The Protection Systems must be capable of recording electrical quantities for each BES Elements it owns connected to the BES buses identified.

The present Protection Systems are either electromechanical or first generation relays not capable of meeting the NERC PRC-002-2 standard requirements of fault recording. Implementation is a phased approach with 50% compliant within four years and fully compliant within six years of the July 1, 2016 effective date. There is a total of 49 affected terminals.

### Mitigation considered

Upgrade the existing Protection Systems on various 230kV and 115kV terminals to Fault Recording (FR) capability per PRC-002 requirements at Beacon, Boulder, Rathdrum, Cabinet Gorge, North Lewiston, Lolo, Pine Creek, Shawnee and Westside.

### Recommendations

- Complete Protection System Upgrades for PRC-002 Business Case.

## 2.12 Rattlesnake Flat Wind Farm

An Interconnection Customer (Project #49) has requested interconnection of a new Wind Power Plant (WPP) generation facility located southeast of Lind, Washington. The customer has chosen an interconnection to Avista's Lind - Washtucna 115kV Transmission Line, approximately 4.5 miles south of the Lind Station, requiring a new 115kV Neilson Station at the Point of Interconnection (POI) with a 115kV line position dedicated for the Interconnection Customer. Project #49 will have an aggregate nameplate capacity of 144MW and will consist of seventy-two (72), Vestas V110, 2.0MW Wind Turbine Generators (WTG).

### Mitigation considered

- Rebuild Lind Station to accept the generator lead line with the POI at Lind Station.

- Construct new Neilson Station as the POI and rebuild the transmission line from Neilson to Lind.

### Recommendations

- Construct network upgrades and direct assigned facilities according to Project #49 Facilities Study.

## 2.13 Saddle Mountain Integration

In the fall of 2013, Grant employees contacted Avista System Planning about performance issues within Grant's system that are exacerbated by Avista's load in the Othello area. The issue was escalated to ColumbiaGrid through the Regional Planning process. It was identified through this process and Avista System Planning that the system performance analysis indeed indicates an inability of the System to meet the performance requirements P1, P2 and P6 categories in Table 1 of NERC TPL-001-4 in current heavy summer scenarios, and P6 categories in heavy winter scenarios.

Studies have identified the following contingency issues:

- Loss of the Benton – Othello SS 115kV line followed by the loss of the Sand Dunes – Warden 115kV line during summer loading may overload the Larson – Sand Dunes – Warden 115kV line (up to 116%).
- Loss of the Larson – Sand Dunes – Warden 115kV line, followed by load restoration (Wheeler to Basset Jct. 115kV line section outage shows worst performance), followed by the loss of the Sand Dunes – Warden 115kV line during spring and summer loading will overload the Benton – Othello SS 115kV line and result in voltage collapse in the Othello area (drops up to 168MW).

### Mitigation considered

- Construct Saddle Mountain Station, one new 115kV transmission line from Saddle Mountain to Othello City, and a new Othello City Station.
- Build new 115kV transmission line into the area from the Stratford area.
- Close normally open points to the east of the area.

### Recommendations

- Complete Saddle Mountain Project (Phase 1 and Phase 2).

## 2.14 Sandpoint System Reinforcement

Load growth around Sandpoint is expected to cause the total load to exceed the capability of the existing 20.8 kV distribution system in the area. The existing Sandpoint Station distribution transformers are unique to Avista's system. Mobile transformers cannot be used to replace a failed transformer at this site. Continued load growth increases the risk of reliability serving customers in the area with potential equipment failure.



Previous transmission system studies have shown P6 contingency performance issues when two of the three transmission lines into the Sandpoint area are out of service. The issues observed were primarily low voltages during heavy winter loading. BPA has also documented in their 2019 System Assessment Summary Report observed performance issues in the area.

### **Mitigation considered**

Rebuild the Bronx Station to provide distribution service to the area.

Construct new 115kV transmission line from Rathdrum or Albeni Falls towards Sandpoint.

### **Recommendations**

- Rebuild the Bronx Station to provide distribution service to the area.
- Perform a detailed project analysis to determine risks and mitigations to low voltages in the area.

## **2.15 Silver Valley System Reinforcement**

The Mission and Big Creek stations in the Silver Valley area have been identified as a concern due to age and condition. The feeder served by Mission Station has protection selectivity concern due to the feeder trunk extending two distinctly different directions.

The age and condition of the Noxon – Pine Creek 230kV Transmission Line has been identified as a concern due to age and condition.

### **Mitigation considered**

The condition of identified stations and transmission lines due to age and condition should be analyzed to determine the scope of rebuilding the assets or target specific equipment replacement.

### **Recommendations**

- Rebuild Big Creek station.
- Upgrade Mission Station with a second feeder position.
- Minor rebuild of Noxon – Pine Creek 230kV Transmission Line.

## **2.16 South Spokane System Reinforcement**

The Spokane area is served by five 230/115kV autotransformers. These autotransformers along with the 115kV transmission lines feeding Spokane load may overload for multiple contingency events during moderate to heavy loading (all seasons). Existing mitigation projects (Ford – Devils Gap 115kV Transmission Line section rebuild, Irvin Switching Station, capacity at Westside) help reduce the amount of overloading, but do not correct known contingency issues. Steady state contingency analysis indicates an inability of the System to meet the performance requirements in requirement R3.1 of TPL-001-4 for the Beacon 115kV tie breaker failure.

Studies have identified the following contingency issues:

- A Beacon 230kV or 115kV bus tie breaker fault (P2.4) may result in an overloaded 230/115kV autotransformer and multiple 115kV transmission lines.
- A Ninth & Central 115kV bus tie breaker fault (P2.4) may result in an overloaded 115kV transmission line.
- Loss of an Addy – Bell 115kV Transmission Line section followed by the loss of any of three 230/115kV autotransformers (P6) may result in an overloaded 230/115 transformer and multiple 115kV transmission lines.
- Loss of any of three 230/115kV autotransformers followed by the loss of a remaining 230/115kV autotransformer (P6) may result in an overloaded 230/115kV autotransformer and multiple 115kV transmission lines.
- Loss of either Beacon – Ninth & Central 115kV transmission line followed by the loss of any of three 115kV transmission lines (P6) may result in an overload of multiple 115kV transmission lines.
- Loss of the Bell – Westside 230kV Transmission Line followed by the loss of any of three 230/115kV autotransformers (P6) may result in an overloaded 230/115 transformer.
- Loss of the College & Walnut – Westside 115kV Transmission Line followed by the loss of any of two 115kV transmission lines (P6) may result in an overload of multiple 115kV transmission lines.

The College & Walnut and Ross Park stations in the Spokane area have been identified as a concern due to age and condition.

The Beacon – Ross Park 115kV Transmission Line has been identified as a concern due to age and condition.

## Mitigation considered

Transmission system contingency issue mitigation alternatives include the following:

- Increase the capacity of the Bell #6 230/115kV Transformer.
  - Does not correct remaining Spokane area 230/115kV transformer loading issues or resolve 115kV line loading issues feeding the West Plains area.
- Rebuild Beacon to a more reliable breaker arrangement or add a series breaker to both the bus tie breakers.
  - Does not correct remaining Spokane area 230/115kV autotransformer loading issues or resolve 115kV transmission line loading issues feeding the West Plains area.
- Rebuild the overloaded 115kV transmission lines
  - Does not correct Spokane area 230/115kV autotransformer loading issues.
- Loop the Beacon – Francis & Cedar 115kV Transmission Line into Bell Station.

- Does not correct Spokane area 230/115kV autotransformer loading issues.
- Build a new 115kV transmission line from Westside Station to the West Plains area or to the Spokane downtown area.
  - Does not correct Spokane 230/115kV autotransformer loading issues.
- Add a new 230/115kV transformation at Ninth & Central Station and associated 230kV transmission lines.

The condition of identified stations and transmission lines due to age and condition should be analyzed to determine the scope of rebuilding the assets or target specific equipment replacement.

### Recommendations

- The identified contingency issues will require a Corrective Action Plan.
- The transmission system contingency mitigation project's specific scope and impact will be evaluated by the responsible parties within Avista to assist in the development of a coordinated business and implementation plan that will be presented to the Engineering Roundtable (ERT) for approval, prioritization, and deployment.
- Construct new Downtown East and Downtown West stations.
- Rebuild College & Walnut and targeted equipment replacement at Ross Park stations.
- Rebuild the Beacon – Ross Park 115kV Transmission Line.

## 2.17 Spokane Valley Transmission Reinforcement

The Spokane Valley Transmission Reinforcement project improves transmission system performance by networking the 115kV transmission lines in the area together at Irvin and Opportunity stations. This reinforcement was necessitated by area load growth along with motor starting voltage issues resulting from the integration of two 25MW synchronous motors at Inland Empire Paper in 2007. Steady state contingency analysis indicates an inability of the System to meet the performance requirement in TPL-001-4 R3.1 for the Boulder 115kV tie breaker failure.

Studies have identified the following contingency issues:

- Loss of a Liberty Lake – Otis Orchards 115kV Transmission Line section or a Nelson – Ninth & Central 115kV Transmission Line section (P2.1) can load the remaining transmission line to its thermal limit. This has resulted in transferring all load growth to adjacent transmission facilities.
- A Boulder 115kV bus tie breaker fault (P2.4) may result in an overloaded 115kV transmission line above 125% of rating.
- Loss of the Beacon – Ross Park 115kV Transmission Line followed by the loss of any of two 115kV transmission lines (P6) may result in an overloaded 115kV transmission line.

- Loss of the College & Walnut – Westside 115kV Transmission Line followed by the loss of any of two 115kV transmission lines (P6) may result in an overload of multiple 115kV transmission lines.
- Loss of the Opportunity – Otis Orchards 115kV Transmission Line followed by the loss of any of two 115kV transmission lines (P6) may result in an overloaded 115kV transmission line.

### Mitigation considered

- This is a vetted project. Refer to past studies for mitigation options.

### Recommendations

- The identified contingency issues will require a Corrective Action Plan.
- Complete Spokane Valley Transmission Reinforcement Business Case including installation of the Irvin Station.
- Increase distribution capacity at Barker Station and add distribution facilities to Irvin Station.
- Rebuild Chester Station.

## 2.18 Stevens/Ferry County System Reinforcement

The Valley Station in the Stevens/Ferry county area has been identified as a concern due to age and condition.

The 49 Degrees North Ski Resort has an expansion plan which will exceed the capacity of the existing distribution system. The existing distribution is being reinforced to accommodate the planned expansion, but there is limited additional capacity.

### Mitigation considered

The condition of identified stations due to age and condition should be analyzed to determine the scope of rebuilding the assets or target specific equipment replacement.

Construct a new 49 Degrees North distribution station to serve additional load growth.

Expand Chewelah Station with a new transformer and dedicated feeder.

### Recommendations

- Rebuild Valley Station.
- Construct a new 49 Degrees North distribution station when customer request is received.

## 2.19 Sunset Station Rebuild

The existing circuit breakers at the station do not have sufficient short circuit interrupting capability to interrupt close in faults on the connected transmission lines. The available fault current increases with the necessary transmission system expansion to address other system

deficiencies (i.e. Westside transformer replacement). Short circuit analysis indicates an inability of the System to meet the performance requirements in requirement R2.8 of TPL-001-4.

### Mitigation considered

Analysis of potential reconfiguration of the station concluded the station should be rebuilt with five transmission line terminals to match the existing station. The analysis reviewed potential reconfigurations with the objective of minimizing the station size. All configurations considered did not provide desired transmission system performance or reliability.

### Recommendations

- The identified issues will require a Corrective Action Plan.
- The Sunset Station has been identified for a complete rebuild.

## 2.20 West Plains System Reinforcement

The West Plains and Sunset area (up to 245MW) is served by (4) 115kV transmission lines, which may overload for multiple contingency events during summer loading. Existing mitigation projects (Garden Springs – Sunset 115kV Transmission Line rebuild and the Ninth & Central – Sunset 115kV Transmission Line rebuild) help reduce the amount of overloading, but do not correct known contingency issues.

Studies have identified the following contingency issues:

- Loss of the Ninth & Central – Sunset 115kV Transmission Line followed by the loss of any of four 115kV transmission lines (P6) may result in an overload of multiple 115kV transmission lines.
- Loss of the Sunset – Westside 115kV Transmission Line followed by the loss of any of six 115kV transmission lines (P6) may result in an overload of multiple 115kV transmission lines.

Load growth in the West Plains area has contributed to heavy loaded distribution facilities. The following stations have feeders which have exceeded 80% of their applicable facility ratings: Airway Heights. Anticipated load growth will increase the feeder loading and reduce necessary operational capacity.

### Mitigation considered

Transmission system contingency issue mitigation alternatives include the following:

- Rebuild the overloaded 115kV transmission lines that were identified in the study.
  - This requires the rebuild of the College & Walnut – Westside, Francis & Cedar – Northwest, Ninth & Central – Third & Hatch, Post Street – Third & Hatch, Ross Park – Third & Hatch and Sunset – Westside 115kV transmission lines.
- Build a new seven mile 115kV transmission line from Westside Station to the West Plains area.

- Add a new 230/115 transformation at Garden Springs and associated 230kV lines.

Construction of new distribution stations and related 115kV transmission line integration will support the anticipated load growth.

### Recommendations

- The transmission system contingency mitigation project's specific scope and impact was evaluated by the responsible parties within Avista to assist in the development of a coordinated business and implementation plan that was presented to the Engineering Roundtable (ERT), approved and prioritized for deployment.
- Construct new Flint Road, McFarlane, and Melville stations with transmission line integration according to the West Plains Reinforcement Plan.

## 2.21 Westside Station Rebuild

Westside Substation was the last remaining Spokane area substation with 125 MVA rated autotransformers. In past studies, the Westside autotransformers would overload for multiple contingency events during moderate to heavy loading in all seasons. The Westside autotransformers are being upgraded to two 250 MVA rated units. Planned reliability improvements to both the 115kV and 230kV bus arrangements are also in this scope, which were required due to increased fault duty from the larger transformers.

Refer to previous studies for identified contingency issues that nucleated the Westside autotransformer upgrade.

The Westside Station is currently being rebuilt, with completion planned for fall of 2022. The construction sequence has resulted in the following temporary contingency issues:

- Loss of the Westside 115kV southwest bus (P2.2) or a breaker failure on the Westside 115kV southwest bus (P2.3) may result in an overload of multiple 115kV transmission lines.

### Mitigation considered

- This is a vetted project, refer to past studies for mitigation options.

### Recommendations

- Complete the installation of the second 250 MVA autotransformer.
- Complete the 230kV Double Breaker Double Bus arrangement.
- Complete the 115kV Double Breaker Double Bus arrangement.

### 3 COMPLETED PROJECTS

Project Name	Project Scope	Targeted Date of Operation
Sandcreek-Bronx-Cabinet Rebuild	Reconductor Bronx to Sand Creek with 795 ACSS	Completed in 2017
Noxon Rapids 230kV Breaker Replacement	Replace 6 limiting circuit breakers with 40kA fault current interrupting capability and operate at a steady state voltage of 253 kV	Completed in 2018
Westside Transformer Replacement	Auto#1 was replaced and placed into service	Completed in 2018
Addy – Devil’s Gap 115kV Transmission Line	Reconductor 5.19 miles (rebuild between Ford and Long Lake Tap) of limiting conductor which consist of 266.8 ACSR and 397.5 ACSR conductor resulting in a capacity limitation of 71.5 MVA at 40°C, to be rebuilt to a capacity of 150 MVA at 40°C (likely 240MVA)	Completed in Jan. 2019 (Data included in 2019 Master Case)
Saddle Mountain Integration	Othello SS – Warden No.1 115kV Transmission Line upgraded to minimum 240 MVA @ 40°C.	Completed in Feb. 2019 (Data included in 2019 Master Case)
Othello – Warden#2 Partial Rebuild (Saddle Mountain)  ** included in 2020 studies	Replace 2.8 Miles of conductor w/ 795 ACSS 200°C from OSS to OTH City.	Completed in March 2019 (Data included in 2019 Master Case)
Lee & Reynolds Rebuild	Substation rebuild. Install 2 – 30 MVA transformers and 6 feeders	Completed in May 2019
Hallett & White Rebuild	Substation rebuild. Install 2 – 30 MVA transformers and 6 feeders	Completed in June 2019
North Lewiston Reactors	Install two 50 MVAr shunt reactors to the existing 230kV bus at North Lewiston Station	Completed in July 2019 (Data included in 2019 Master Case)
Ford Substation Rebuild	Rebuild station with 10 MVA transformer. Tapped off of ADD-DGP line	Completed in December 2019
Boulder Substation	Install 1 – 30 MVA transformer for load support	Completed in October 2019
Priest River	Feeder bay rebuild, expanded to two feeders	Completed in October 2018

TABLE 2 COMPLETED PROJECTS

# VTECHNICAL ANALYSIS RESULTS

## 1 STEADY STATE CONTINGENCY ANALYSIS

The state of the current system study examined system normal and outage simulations on all seasons of the 2020 base cases to determine the present 'state of the system' as it exists today. The existing system configuration was modeled in 2020 Heavy and Light Summer, 2020-21 Heavy and Light Winter, 2020 Spring (high generation, low load) and 2020 high east to west transfer (Montana-Northwest Path 8 and West of Hatwai Path 6 near limits).

Included in the 2020 cases were completed projects and select projects under construction. Significant system reinforcements or system changes since 2018 are as follows:

- Ninth and Central distribution load moved onto the 115kV bus.
- Westside 230/115 auto-transformers increased to 250 MVA.
- Coeur d'Alene – Pine Creek 115kV line increased capacity to 240 MVA.
- Adams-Neilson Solar (20 MVA) interconnected at Lind Substation.
- Cabinet – Bronx – Sand Creek 115kV line increased capacity to 143 MVA.
- Addy – Devils Gap 115kV line increased capacity to 120 MVA.
- Lind – Warden 115kV line increased capacity to 262 MVA.
- Othello SS – Warden #1 115kV line increased capacity to 262 MVA.
- Othello SS – Warden #2 115kV line increased capacity to 123 MVA.
- North Lewiston Reactors – two steps of 50 MVA each.
- Benton – Othello SS 115kV line increased capacity to 138 MVA

Known outages of generation or transmission facilities with a duration of at least six months were also included in the 2020 cases as follows:

- Lancaster – Noxon 230kV line derated to 255 MVA by BPA beginning in 2017.

Study results show several previously known issues are now resolved, and few new problems have been observed in the current studies. None of the contingencies evaluated resulted in Instability, Cascading, Uncontrolled Separation or IROLs. Study results are summarized as follows.

### 1.1 Thermal Issues

P0 – No system elements show thermal overload under system normal conditions.

P1.1-P1.4 – No system elements show thermal overload under N-1 conditions, such as the loss of a generator, transmission circuit, transformer or shunt device.

P2.1 – No system elements show thermal overload with the opening of a line section without a fault during peak loading.

- Loss of the Liberty Lake – Otis Orchards 115kV line section during summer loading may load the Ninth & Central – Opportunity 115kV line (up to 98%).



- Loss of the Nelson – Ninth & Central 115kV line section during summer loading may load the Opportunity – Otis Orchards 115kV line (up to 98%).
- Planned mitigation is to complete the Spokane Valley Transmission Reinforcement (fall of 2021).

P2.2 – Several system elements can become thermally overloaded resulting from a bus section fault during peak loading.

- Loss of the Lolo 115kV bus during summer loading may overload the Clearwater – North Lewiston 115kV line (up to 96%, 116% if either Clearwater generator is offline)
  - The Clearwater – North Lewiston 115kV line is protected by thermal relays and will automatically drop load (157MW of load, 48MW of generation) when overloaded per SOP 03.
- Loss of the Hot Springs 230kV bus during high Montana to Northwest (Path 8) transfers may overload the Lancaster – Rathdrum 230kV line (up to 107%).
  - Known issue with BPA’s Lancaster – Rathdrum 230kV line derate. BPA will mitigate in real time until the line derate is corrected (fall of 2021).
- Loss of the Rathdrum 115kV east bus during summer loading may overload the Rathdrum 230/115 transformer #1 (up to 103%) and overload the Ramsey – Rathdrum #1 115kV line (up to 109%).
  - Existing mitigation is transfer Coeur d’Alene area load to Pine Creek.
  - Refer to Coeur d’Alene System Reinforcement.
- Loss of the Westside 115kV southwest bus during summer loading may overload the Ross Park – Third & Hatch 115kV line (up to 114%), the Francis & Cedar – Northwest 115kV line (up to 105%), and the Post Street – Third & Hatch 115kV line (up to 111%).
  - Existing mitigation is to shed load (up to 60MW) in the South Spokane area until Westside rebuild is complete.
  - Planned mitigation is to complete the Westside Station Rebuild (fall of 2022).
- Loss of the Larson 115kV bus during spring and summer loading may overload the Chelan - Stratford 115kV line (up to 112%).
  - Existing mitigation is to move open point on the Devils Gap – Stratford 115kV line to Devils Gap.

P2.3 – Several system elements can become thermally overloaded resulting from an internal breaker fault (non-bus tie breaker) during peak loading:

- A breaker failure on the Lolo 115kV bus (5 CB’s & 1 CS) during summer loading may overload the Clearwater – North Lewiston 115kV line (up to 96%, 116% if either Clearwater generator is offline).

- The Clearwater – North Lewiston 115kV line is protected by thermal relays and will automatically drop load (157MW of load, 48MW of generation) when overloaded per SOP 03.
- A breaker failure on the Hot Springs 230kV bus (6 CB's) during high east to west transfers may overload the Lancaster – Rathdrum 230kV line (up to 106%).
  - Known issue with BPA's Lancaster – Rathdrum 230kV line derate. BPA will mitigate in real time until derate is corrected (fall of 2021).
- A breaker failure on the Rathdrum 115kV east bus (7 CB's) during summer loading may overload the Ramsey – Rathdrum #1 115kV line (up to 101%) and load the Rathdrum 230/115 transformer #1 to near rating.
  - Existing mitigation is transfer Coeur d'Alene area load to Pine Creek.
  - Refer to Coeur d'Alene System Reinforcement.
- A breaker failure on the Westside 115kV southwest bus (3 CB's) during summer loading may overload the Ross Park – Third & Hatch 115kV line (up to 114%), the Francis & Cedar – Northwest 115kV line (up to 105%), and the Post Street – Third & Hatch 115kV line (up to 111%).
  - Existing mitigation is to shed load (up to 60MW) in the South Spokane area.
  - Planned mitigation is to complete the Westside Station Rebuild (fall of 2022).
- A breaker failure on the Larson 115kV bus (9 CB's) during spring and summer loading may overload the Chelan - Stratford 115kV line (up to 112%).
  - Existing mitigation is to move open point on the Devils Gap – Stratford 115kV line to Devils Gap.

P2.4 – Several system elements can become thermally overloaded resulting from an internal breaker fault on a bus tie breaker during peak loading:

- A Beacon 230kV bus tie breaker failure during summer loading may overload the Bell 230/115 transformer #6 (up to 100%), the Bell – Northeast 115kV line (up to 114%), and the Francis & Cedar – Northwest 115kV line (up to 105%).
  - Existing mitigation is to shed load (up to 40MW) in the North Spokane area.
  - Refer to South Spokane Transmission Reinforcement.
- A Beacon 115kV bus tie breaker failure during summer loading may overload the Opportunity – Otis Orchards 115kV line (up to 122%), the Francis & Cedar – Northwest 115kV line (up to 121%), the Northwest – Westside 115kV line (up to 116%), and the College & Walnut – Westside 115kV line (up to 102%).
  - Existing mitigation is to shed load (up to 90MW) in the South Spokane area.
  - Refer to South Spokane Transmission Reinforcement.
- A Boulder 115kV bus tie breaker failure during summer loading may overload the Ninth & Central – Opportunity 115kV line (up to 147%).

- Existing mitigation is to shed load (up to 56MW) east of Otis Orchards.
- Planned mitigation is to complete the Spokane Valley Transmission Reinforcement (fall of 2021).
- A Ninth & Central 115kV bus tie breaker failure during summer loading may overload the Ross Park – Third & Hatch 115kV line (up to 95%, 100% with W2E offline).
  - Existing mitigation is to shed load (up to 10MW) in the South Spokane area.
  - Refer to South Spokane Transmission Reinforcement.

P3 – Several system elements can become thermally overloaded resulting from the loss of a generator; followed by system adjustments; followed by a subsequent loss of an additional transmission circuit, transformer or shunt device.

- Loss of Clearwater unit #3 or #4 followed by the loss of either Clearwater 115/34 transformer during any seasonal loading may overload the remaining Clearwater 115/34 transformer (up to 113%).
  - Existing mitigation is to reduce facility load.
- Loss of Clearwater generator unit #3 or #4 followed by the loss of Hatwai – Lolo 230kV line during summer loading may overload the Clearwater – North Lewiston 115kV line (up to 107%).
  - The Clearwater – North Lewiston 115kV line is protected by thermal relays and will automatically drop load when overloaded per SOP 03.

P4 and P5 – No further results beyond those identified in P2.2 thru P2.4

P6 – Several system elements can become thermally overloaded resulting from an N-1-1 contingency event. This is described as the loss of a transmission circuit, transformer or shunt device; followed by system adjustments; followed by a subsequent loss of an additional transmission circuit, transformer or shunt device.

- Loss of the Addy – Bell 115kV line, followed by load restoration (Addy to Loon Lake 115kV line section outage shows worst performance), followed by:
  - The loss of either Beacon 230/115 transformer during summer loading may overload the Bell 230/115 transformer #6 (up to 105%).
    - Existing mitigation is for BPA to operate within their short term rating.
  - The loss of Bell 230/115 transformer #6 during summer loading may overload the Beacon – Bell 115kV line (up to 113%) and Beacon – Northeast 115kV line (up to 102%).
    - Existing mitigation is to transfer Waikiki to Beacon - Francis & Cedar 115kV line.
    - Refer to North Spokane Transmission Reinforcement.
- Loss of the Airway Heights – Devils Gap 115kV line, followed by load restoration (Devils Gap – West Plains 115kV line section outage shows worst performance), followed by:

- The loss of Nine Mile – Westside 115kV line during light spring loading may overload the Addy – Devils Gap 115kV line (up to 107%).
  - Existing mitigation is to limit generation at Nine Mile to 8MW per SOP 20
  - Planned mitigation is to complete the Addy – Devils Gap 115kV line section rebuild by correcting bottleneck at Devils Gap (spring of 2020).
- Loss of the either Beacon 230/115 transformer followed by:
  - The loss of the remaining Beacon 230/115 transformer during summer loading may overload the Bell 230/115 transformer #6 (up to 126%), the Beacon – Northeast 115kV line (up to 104%), and the Francis & Cedar – Northwest 115kV line (up to 100%).
    - Existing mitigation is for BPA to operate within their short term rating and for Avista to shed load (up to 33MW) at Waikiki or bring up Northeast CT
    - Refer to West Plains System Reinforcement and South Spokane Transmission Reinforcement.
  - The loss of Bell 230/115 transformer #6 during summer loading may overload the remaining Beacon 230/115 transformer (up to 119%).
    - Existing mitigation is for BPA and Avista to shed load (up to 80MW) in the north Spokane area
    - Refer to West Plains System Reinforcement and South Spokane Transmission Reinforcement.
- Loss of the either Beacon – Bell 230kV line followed by:
  - The loss of the remaining Beacon - Bell 230kV line during summer loading may overload the Bell 230/115 transformer #6 (up to 118%).
    - Existing mitigation is for BPA to operate within their short term rating.
- Loss of the Beacon – Bell 115kV line, followed by:
  - The loss of Bell 230/115 transformer #6 during summer loading may overload the Beacon – Northeast 115kV line (up to 126%) and the Bell – Northeast 115kV line (up to 102%).
    - Existing mitigation is to transfer Waikiki to Francis & Cedar.
    - Refer to North Spokane System Reinforcement.
- Loss of the either Beacon – Ninth & Central 115kV line followed by:
  - The loss of the remaining Ninth & Central 115kV line during summer loading may overload the Ross Park – Third & Hatch 115kV line (up to 123%).
    - Existing mitigation is to shed load (up to 70MW) in the South Spokane area.

- Refer to West Plains System Reinforcement and South Spokane Transmission Reinforcement.
  - The loss of the Beacon – Ross Park 115kV line during summer loading may overload the remaining Beacon – Francis & Cedar 115kV line (up to 106%).
    - Existing mitigation is to open Ninth & Central – Opportunity 115kV line at Ninth & Central
    - Refer to West Plains System Reinforcement and South Spokane Transmission Reinforcement.
  - The loss of the Ross Park – Third & Hatch 115kV line during summer loading may overload the remaining Beacon – Francis & Cedar 115kV line (up to 102%).
    - Existing mitigation is to open Ninth & Central – Opportunity 115kV line at Ninth & Central
    - Refer to West Plains System Reinforcement and South Spokane Transmission Reinforcement.
- Loss of the Beacon – Northeast 115kV line, followed by:
  - The loss of Bell 230/115 transformer #6 during summer loading may overload the Beacon – Bell 115kV line (up to 162%).
    - BPA has to radialize their load at Bell pre-contingency
    - Refer to North Spokane System Reinforcement.
- Loss of the Beacon – Ross Park 115kV line followed by:
  - The loss of the either Beacon – Ninth & Central 115kV line during summer loading may overload the remaining Beacon – Ninth & Central 115kV line (up to 107%).
    - Existing mitigation is to open Ninth & Central – Opportunity 115kV line at Ninth & Central.
    - Planned mitigation is to complete the Spokane Valley Transmission Reinforcement (fall of 2021).
- Loss of the Bell 230/115 transformer #6 followed by:
  - The loss of the either Beacon 230/115 transformer during summer loading may overload the remaining Beacon 230/115 transformer (up to 118%).
    - Existing mitigation is to shed load (up to 80MW) in the north Spokane area
    - Refer to West Plains System Reinforcement and South Spokane Transmission Reinforcement.
  - The loss of the Beacon – Northeast 115kV line during summer loading may overload the Beacon – Bell 115kV line (up to 162%).
    - BPA and Avista shed load (up to 80MW) in the north Spokane area.

- Refer to North Spokane System Reinforcement.
- The loss of the Beacon – Bell 115kV line during summer loading may overload the Beacon – Northeast 115kV line (up to 126%).
  - Planning mitigation is to transfer Waikiki to Francis & Cedar.
  - Refer to North Spokane System Reinforcement.
- Loss of the Bell – Northeast 115kV line, followed by load restoration (Waikiki will auto-transfer to the Beacon – Francis & Cedar 115kV line), followed by:
  - The loss of Bell 230/115 transformer #6 during summer loading may overload the Beacon – Bell 115kV line (up to 105%).
    - BPA has to radialize their load at Bell pre-contingency
    - Refer to North Spokane System Reinforcement.
- Loss of the Bell – Westside 230kV line followed by:
  - The loss of either Beacon 230/115 transformer during summer loading may overload the Bell 230/115 transformer #6 (up to 107%) and the remaining Beacon 230/115 transformer (up to 106%).
    - Existing mitigation is for BPA to operate within their short term rating on Bell 230/115 transformer #6 and for Avista to shed load (up to 50MW) at Waikiki.
    - Refer to West Plains System Reinforcement and South Spokane Transmission Reinforcement.
- Loss of the Benewah – Boulder 230kV line followed by:
  - Loss of the Dworshak – Hatwai 500 during high east to west transfers may overload the Benewah – Pine Creek 230kV line (up to 126%).
    - Existing mitigation is to limit WMH to 1450MW and reduce Avista's share of MT-NW by 200MW per SOP 28.
- Loss of the Benewah – Pine Creek 230kV line followed by:
  - Loss of the Cabinet – Rathdrum 230 line during high east to west transfers may overload the Lancaster - Noxon 230kV line (up to 134%).
    - Existing mitigation is to limit WMH to 1350MW and reduce Avista's share of MT-NW by 200MW per SOP 28.
- Loss of the Benton – Othello SS 115kV line, followed by load restoration (Benton to South Othello 115kV line section outage shows worst performance), followed by:
  - The loss of the Sand Dunes – Warden 115kV line during summer loading may overload the Larson – Sand Dunes – Warden 115kV line (up to 116%).
    - Existing mitigation is to open the Larson – Sand Dunes – Warden 115kV line at Warden per SOP 21.

- Planned mitigation is to complete the Saddle Mountain project Phase I and II (fall of 2022).
- Loss of the Cabinet - Noxon 230kV line followed by:
  - Loss of the Noxon – Pine Creek 230kV line during high WMH and east to west transfers may overload the Lancaster - Noxon 230kV line (up to 145%).
    - Existing mitigation is to arm RAS, limit Cabinet Gorge to 200MW, limit WMH to 1200MW and reduce Avista’s share of MT-NW by 200MW per SOP 28.
- Loss of the College & Walnut – Westside 115kV line, followed by load restoration (Fort Wright – Westside 115kV line section outage shows worst performance), followed by:
  - The loss of the Ninth & Central – Third & Hatch 115kV line during summer loading may overload the Ross Park – Third & Hatch 115kV line (up to 105%).
    - Existing mitigation is to shed load (up to 10MW) at Fort Wright.
    - Refer to West Plains System Reinforcement and South Spokane Transmission Reinforcement.
  - The loss of the either Beacon – Ninth & Central 115kV line during summer loading may overload the remaining Beacon – Ninth & Central 115kV line (up to 101%).
    - Existing mitigation is to open Ninth & Central – Opportunity 115kV line at Ninth & Central
    - Planned mitigation is to complete the Spokane Valley Transmission Reinforcement (fall of 2021).
- Loss of the Devils Gap - Stratford 115kV line, followed by load restoration (Stratford – Wilson Creek 115kV line section outage shows worst performance), followed by:
  - The loss of the Larson - Stratford 115kV line during summer loading may overload the Chelan - Stratford 115kV line (up to 107%).
    - Existing mitigation is to open the Chelan - Stratford 115kV line at Stratford per SOP 21.
- Loss of the Dry Creek – North Lewiston 230kV line followed by:
  - Loss of the Hatwai - Lolo 230kV line during summer loading and high ID-NW transfers may overload the Clearwater – North Lewiston 115kV line (up to 167%), Dry Creek – North Lewiston 115kV line (up to 121%), and North Lewiston 230/115 transformer #1 (up to 138%).
    - Existing mitigation is to arm Lolo-Oxbow Back Trip, open Lolo – Pound Lane 115kV line at Lolo, open Lolo – Nez Perce 115kV line at Nez Perce, Open Dry Creek – North Lewiston 115kV line at North Lewiston, and open Dry Gulch 69 kV tie.

- Refer to Lewiston/Clarkston System Reinforcement.
- Loss of the Francis & Cedar – Ross Park 115kV line, followed by load restoration (Lions & Standard – Ross Park 115kV line section outage shows worst performance), followed by:
  - The loss of the Northwest - Westside 115kV line during summer loading may overload the Beacon – Francis & Cedar 115kV line (up to 109%).
    - Existing mitigation is to open the Beacon – Francis & Cedar 115kV line at Francis & Cedar.
    - Refer to North Spokane System Reinforcement.
- Loss of the Larson – Stratford 115kV line, followed by:
  - The loss of the Devils Gap - Stratford 115kV line during spring and summer loading may overload the Chelan - Stratford 115kV line (up to 107%).
    - Existing mitigation is to limit generation at Main Canal and Summer Falls to a total of 90MW per SOP 21.
- Loss of the Larson – Sand Dunes – Warden 115kV line, followed by load restoration (Wheeler to Basset Junction 115kV line section outage shows worst performance), followed by:
  - The loss of the Sand Dunes – Warden 115kV line during spring and summer loading will overload the Benton – Othello SS 115kV line and result in voltage collapse in the Othello area (drops up to 168MW).
    - Existing mitigation is to open the Benton – Othello SS 115kV line at Othello SS per SOP 21.
    - Planned mitigation is to complete the Saddle Mountain project Phase I and II (fall of 2022). This still results in low voltage on GCPD's system.
- Loss of the Hatwai – Lolo 230kV line followed by:
  - Loss of the Dry Creek – Lolo 230kV line during summer loading and high ID-NW transfers may overload the Clearwater – North Lewiston 115kV line (up to 197%) and Dry Creek – Pound Lane 115kV line (up to 119%) or the;
  - Loss of the Dry Creek – North Lewiston 230kV line during summer loading and high ID-NW transfers may overload the Clearwater – North Lewiston 115kV line (up to 167%), Dry Creek – North Lewiston 115kV line (up to 121%), and North Lewiston 230/115 transformer #1 (up to 138%) or the;
  - Loss of the North Lewiston 230/115 transformer during summer loading and high ID-NW transfers may overload the Dry Creek – North Lewiston 230kV line (up to 116%).
    - Arm Lolo-Oxbow Back Trip, open Lolo – Pound Lane 115kV line at Lolo, open Lolo – Nez Perce 115kV line at Nez Perce, Open Dry Creek – North



Lewiston 115kV line at North Lewiston, and open Dry Gulch 69 kV tie per SOP 33.

- This leaves Clearwater – North Lewiston 115kV line in service, but ready to trip via thermal relays for a subsequent outage.
    - Refer to Lewiston/Clarkston System Reinforcement.
- Loss of the Moscow 230/115 transformer followed by:
  - The loss of the Shawnee 230/115 transformer during any season will overload the Moscow – Orofino 115kV line and result in voltage collapse in the Moscow/Pullman area (drops up to 186MW).
    - Existing mitigation is to open the Moscow – Orofino 115kV line at Moscow. No current System Operating Procedure.
    - Can only recover load in the Moscow area (from Orofino & North Lewiston), which leaves up to 70MW offline until autotransformer issue is corrected,
    - Refer to Palouse System Reinforcement.
- Loss of the Moscow – South Pullman 115kV line, followed by load restoration (Moscow – North Moscow 115kV line section outage shows worst performance), followed by:
  - The loss of the Shawnee 230/115 transformer during summer loading may overload the Moscow – Terre View 115kV line (up to 110%).
    - Existing mitigation is to transfer Moscow City load to North Lewiston.
    - Refer to Palouse System Reinforcement.
- Loss of the Moscow – Terre View 115kV line, followed by load restoration (Moscow – North Moscow 115kV line section outage shows worst performance), followed by:
  - The loss of the Shawnee 230/115 transformer during summer loading may overload the Moscow – South Pullman 115kV line (up to 107%).
    - Existing mitigation is to transfer Moscow City load to North Lewiston.
    - Refer to Palouse System Reinforcement.
- Loss of the North Lewiston 230/115 transformer followed by:
  - Loss of the Hatwai - Lolo 230kV line during summer loading and high ID-NW transfers may overload the Dry Creek – North Lewiston 115kV line (up to 98%),
    - Arm Lolo-Oxbow Back Trip per SOP 33.
    - Refer to Lewiston/Clarkston System Reinforcement.
- Loss of the Nine Mile – Westside 115kV line, followed by load restoration (Indian Trail – Westside 115kV line section outage shows worst performance), followed by:
  - The loss of Airway Heights – Devils Gap 115kV line during light spring loading may overload the Addy – Devils Gap 115kV line (up to 107%).

- Existing mitigation is to limit generation at Nine Mile to 8MW per SOP 20
  - Planned mitigation is to complete the Addy – Devils Gap 115kV line section rebuild by correcting bottleneck at Devils Gap (spring of 2020).
- Loss of the Ninth & Central – Sunset 115kV line, followed by load restoration (Glenrose – Ninth & Central 115kV line section outage shows worst performance), followed by:
  - The loss of the Beacon – Ross Park 115kV line during summer loading may overload the Ninth & Central – Third & Hatch 115kV line (up to 91%, 95% with W2E offline, increases to 100% after Irvin is complete).
    - Refer to West Plains System Reinforcement and South Spokane Transmission Reinforcement.
  - The loss of the Metro – Post Street 115kV line during summer loading may overload the Sunset – Westside 115kV line (up to 106%, 105% with W2E offline, increases to 109% after Irvin is complete).
    - Planned mitigation is to complete the Metro Substation rebuild and associated projects (spring of 2024).
  - The loss of the Metro – Sunset 115kV line during summer loading may overload the Sunset - Westside 115kV line (up to 96%, 96% with W2E offline, increases to 99% after Irvin is complete).
    - Refer to West Plains System Reinforcement.
  - The loss of the Ninth & Central – Third & Hatch 115kV line during summer loading may overload the Ross Park – Third & Hatch 115kV line (up to 98%, 103% with W2E offline, increases to 108% after Irvin is complete).
    - Refer to West Plains System Reinforcement.
- Loss of the Noxon – Pine Creek 230kV line followed by:
  - Loss of the Cabinet - Rathdrum 230kV line during high WMH and east to west transfers may overload the Lancaster - Noxon 230kV line (up to 121%).
    - Existing mitigation is to arm RAS, limit WMH to 1350MW and reduce Avista's share of MT-NW by 200MW per SOP 28.
- Loss of the Opportunity – Otis Orchards 115kV line, followed by load restoration (Liberty Lake – Otis Orchards line section outage shows worst performance), followed by:
  - The loss of the either Beacon 230/115 transformer during summer loading may overload the remaining Beacon 230/115 transformer (up to 98%).
    - Refer to West Plains System Reinforcement and South Spokane Transmission Reinforcement.
  - The loss of the either Ninth & Central 115kV line during summer loading may overload the remaining Ninth & Central 115kV line (up to 108%).
    - Existing mitigation is to shed load (up to 20MW) in the South Spokane area.

- Planned mitigation is to complete the Spokane Valley Transmission Reinforcement (fall of 2021).
- Loss of the Othello SS – Warden #2 115kV line, followed by load restoration (Lee & Reynolds - Warden 115kV line section outage shows worst performance), followed by:
  - The loss of the Othello SS – Warden #1 115kV line during spring and summer loading may overload the Benton – Othello SS 115kV line (up to 125%).
    - Existing mitigation is to open the Benton – Othello SS 115kV line at Othello SS per SOP 21.
    - Planned mitigation is to complete the Benton – Othello SS project (spring of 2020).
- Loss of the Pine Street – Rathdrum 115kV line, followed by load restoration (Old Town – Pine Street 115kV line section outage shows worst performance), followed by:
  - The loss of the Rathdrum 230/115 transformer #2 during summer loading may overload the remaining Rathdrum 230/115 transformer #1 (up to 117%, 96% with CDA-PIN 115 closed).
    - Existing mitigation is to operate Coeur d'Alene – Pine Creek 115kV closed through per SOP 36.
    - Refer to Coeur d'Alene System Reinforcement.
- Loss of either Rathdrum 230/115 transformer followed by:
  - The loss of the remaining Rathdrum 230/115 transformer during any season will overload the Pine Street – Rathdrum 115kV line and result in voltage collapse in the Coeur d'Alene area (drops up to 275MW).
    - Existing mitigation is to open the Pine Street – Rathdrum 115kV line at Rathdrum per SOP 36. Note that closing though on the Coeur d'Alene – Pine Creek 115kV does not mitigate for the loss of both Rathdrum 230/115 transformers, due to Pine Street – Rathdrum 115kV line overload (up to 127%).
    - Refer to Coeur d'Alene System Reinforcement.
- Loss of the Sand Dunes – Warden 115kV line, followed by:
  - The loss of the Larson – Sand Dunes – Warden 115kV line during summer loading may overload the Benton – Othello SS 115kV line (up to 212%).
    - Existing mitigation is to open the Larson – Sand Dunes – Warden 115kV line at Warden per SOP 21.
    - Planned mitigation is to complete the Benton – Othello SS project (spring of 2020).
- Loss of the Sunset – Westside 115kV line, followed by load restoration (Garden Springs – Waste to Energy 115kV line section outage shows worst performance), followed by:

- The loss of the Airway Heights – Devils Gap 115kV line during summer loading may overload the College & Walnut – Westside 115kV line (up to 102%).
  - Existing mitigation is to shed load (up to 10MW) at Fort Wright.
  - Refer to West Plains System Reinforcement.
- The loss of the College & Walnut – Westside 115kV line during summer loading may overload the Francis & Cedar – Northwest 115kV line (up to 102%), the Post Street – Third & Hatch 115kV line (up to 103%), and the Ross Park – Third & Hatch 115kV line (up to 110%).
  - Existing mitigation is to shed load (up to 50MW) in the South Spokane area.
  - Refer to West Plains System Reinforcement and South Spokane Transmission Reinforcement.
- The loss of the Francis & Cedar – Northwest 115kV line during summer loading may overload the College & Walnut – Westside 115kV line (up to 111%).
  - Existing mitigation is to shed load (up to 40MW) in the South Spokane area.
  - Refer to West Plains System Reinforcement and South Spokane Transmission Reinforcement.
- The loss of the Metro – Post Street 115kV line during summer loading may overload the Ninth & Central – Sunset 115kV line (up to 114%).
  - Existing mitigation is to shed load (up to 20MW) in the South Spokane area.
  - Planned mitigation is to complete the Metro Substation rebuild and associated projects (spring of 2024).
- The loss of the Metro – Sunset 115kV line during summer loading may overload the Ninth & Central – Sunset 115kV line (up to 102%).
  - Existing mitigation is to shed load (up to 10MW) in the South Spokane area.
  - Planned mitigation is to complete the Ninth & Central – Sunset 115kV line rebuild (Southeast Substation bottleneck) (spring of 2020).
- The loss of the Northwest – Westside 115kV line during summer loading may overload the College & Walnut – Westside 115kV line (up to 119%).
  - Existing mitigation is to shed load (up to 80MW) in the South Spokane area.
  - Refer to West Plains System Reinforcement and South Spokane Transmission Reinforcement.

- The loss of the Post Street – Third & Hatch 115kV line during summer loading may overload the College & Walnut – Westside 115kV line (up to 109%).
  - Existing mitigation is to shed load (up to 30MW) in the South Spokane area.
  - Refer to West Plains System Reinforcement.
- The loss of the Ross Park – Third & Hatch 115kV line during summer loading may overload the College & Walnut – Westside 115kV line (up to 103%).
  - Existing mitigation is to shed load (up to 10MW) at Fort Wright.
  - Refer to West Plains System Reinforcement and South Spokane Transmission Reinforcement.
- Loss of the Sunset – Westside 115kV line, followed by gen/load restoration (Waste to Energy – Westside 115kV line section outage shows worst performance), followed by:
  - The loss of the College & Walnut – Westside 115kV line during summer loading may overload the Ross Park – Third & Hatch 115kV line (up to 104%).
    - Existing mitigation is to shed load (up to 20MW) in the South Spokane area.
    - Refer to West Plains System Reinforcement and South Spokane Transmission Reinforcement.
  - The loss of the Francis & Cedar – Northwest 115kV line during summer loading may overload the College & Walnut – Westside 115kV line (up to 104%).
    - Existing mitigation is to shed load (up to 20MW) in the South Spokane area.
    - Refer to West Plains System Reinforcement and South Spokane Transmission Reinforcement.
  - The loss of the Metro – Post Street 115kV line during summer loading may overload the Ninth & Central – Sunset 115kV line (up to 102%).
    - Existing mitigation is to shed load (up to 10MW) in the South Spokane area.
    - Planned mitigation is to complete the Ninth & Central – Sunset 115kV line rebuild (Southeast Substation bottleneck) (spring of 2020).
  - The loss of the Northwest – Westside 115kV line during summer loading may overload the College & Walnut – Westside 115kV line (up to 112%).
    - Existing mitigation is to shed load (up to 50MW) in the South Spokane area.
    - Refer to West Plains System Reinforcement and South Spokane Transmission Reinforcement.

- The loss of the Post Street – Third & Hatch 115kV line during summer loading may overload the College & Walnut – Westside 115kV line (up to 102%).
  - Existing mitigation is to shed load (up to 10MW) in the South Spokane area.
  - Refer to West Plains System Reinforcement.
- The loss of the Ross Park – Third & Hatch 115kV line during summer loading may overload the College & Walnut – Westside 115kV line (up to 97%).

P7 – No system elements show thermal overload resulting from an N-2 contingency event. This is described as the loss of any two adjacent circuits on common structure (vertical or horizontal) and excludes circuits of (1) mile.

## 1.2 Voltage Issues

P0 – No voltage issues were identified under system normal conditions.

- Minor high voltage is observed under system normal and off-peak loading conditions in the Big Bend area.
  - Issue remains under observation.
- Minor low voltage has been observed under system normal conditions in PacifiCorp's 69 kV system.
  - PacifiCorp planned mitigation is to upgrade the Dry Gulch 115/69 kV transformer from 20 MVA to a 50 MVA transformer with voltage regulation (LTC).

P1.1-P1.4 – No voltage issues were identified under N-1 conditions, such as the loss of a generator, transmission circuit, transformer or shunt device.

P2.1 – Several voltage issues were identified with the opening of a line section w/o a fault during peak loading:

- Loss of the Roxboro – Warden 115kV line section requires transferring area load to Devils Gap and/or Shawnee, may result in low voltage at Roxboro (0.93pu).
  - Existing mitigation is to shed load at Roxboro (up to 20MW) per SOP 21.
- Loss of the Stratford – Wilson Creek 115kV line section requires transferring area load to Devils Gap, which may result in a high voltage step change (0.06pu) when inserting each 13.4 MVar step at Othello.
  - Step change in voltage results in up to 40MW of irrigation load loss.
  - Planned mitigation is to investigate reducing cap bank step size.
- Loss of the Garden Springs – Hayford 115kV line section requires transferring area load to Airway Heights, which may result in low voltage at Cheney (0.95pu).
  - Existing mitigation is to transfer Cheney and Four Lakes to the Sunset – Shawnee 115kV line per SOP 12.

P2.2 – Several voltage issues were identified resulting from a bus section fault during peak loading:

- Loss of the Sand Dunes 115kV bus during summer loading may result in low voltage at Ritzville (0.95pu) and Othello City (0.95pu).
  - Existing mitigation is to transfer load at Ritzville to Devils Gap

P2.4 – Several voltage issues were identified resulting from an internal breaker fault on a bus tie breaker during peak loading:

- A Boulder 115kV bus tie breaker failure during summer loading may result in voltage collapse in the Spokane Valley.
  - Shed load east of Otis Orchards

P3 – No further results beyond those identified in P1 and P2.1

P4 & P5 – No further results beyond those identified in P2.2 thru P2.4

P6 – No voltage issues were identified resulting from an N-1-1 contingency event that were not captured in the previous thermal results section. This is described as the loss of a transmission circuit, transformer or shunt device; followed by system adjustments; followed by a subsequent loss of an additional transmission circuit, transformer or shunt device.

P7 – No voltage issues were identified resulting from an N-2 contingency event. This is described as the loss of any two adjacent circuits on common structure (vertical or horizontal) and excludes circuits of (1) mile.

### 1.3 Radial and Consequential Load Loss Issues

The present steady state contingency analysis methods allows for observation of consequential load loss for each studied contingency. Improved study methods are desired to capture both the amount of consequential load loss and the inability to restore service to customers. The following list identifies transmission system contingencies resulting in undesired consequential load loss. The list is not comprehensive of all radial transmission system elements and will be improved in subsequent studies.

- P1.1 – Loss of the Addy - Gifford 115kV line during any season results in an outage to Gifford (9MW)
  - Addy has a main/aux bus arrangement for substation related outages at Addy
- P1.1 – Loss of the Lind – Washtucna 115kV line during any season results in an outage to Delight and Washtucna (total of 3MW)
  - The Lind bypass switch provides service for substation related outages at Lind
- P1.1 – Loss of the Orofino – Weippe 115kV line during any season results in an outage to Weippe (4MW)
  - The Orofino bypass switch A196 provides service for substation related outages at Orofino

- P1.3 – Loss of the Benewah 230/115 transformer #1 (drops 20MW load), followed by load restoration (transfer Setters load to Ninth & Central and close the Benewah – Pine Creek 115kV line) did not result in load loss after load was restored from alternate sources.
- P1.3 – A trip of either Cabinet Gorge GSU A or B (P1.3) during any season will drop all units at Cabinet Gorge (up to 260MW) and clears the Cabinet 230kV bus due to the lack of a high side GSU breaker. This outage severs the (2) primary station service feeds at Cabinet Gorge Hydro, it open ends the Cabinet – Noxon 230kV line, the Cabinet – Rathdrum 230kV line and the Cabinet 230/115kV autotransformer, it results in a reduction in WMH to 1100MW and cuts MT-NW by 200MW.
  - Refer to Cabinet Gorge GSU Isolation.
- P2.4 – A Rathdrum 115kV bus tie breaker failure during any season drops load in the Coeur d’Alene area (drops up to 275MW).
- P7 / P6 – A forced outage of Beacon – Rathdrum 230kV line and Lancaster – Rathdrum 230kV line (common structure), followed by:
  - The loss of the Cabinet – Rathdrum 230kV line during any season will overload the Pine Street – Rathdrum 115kV line and result in voltage collapse in the Coeur d’Alene area (drops up to 275MW).
    - Open the Pine Street – Rathdrum 115kV line at Rathdrum per SOP 36
    - Refer to Coeur d’Alene System Reinforcement.

## 2 VOLTAGE STABILITY ANALYSIS

No QV or PV issues were identified during this assessment.



### 3 STABILITY CONTINGENCY ANALYSIS

The following transient stability issues were identified during this assessment.

#### 3.1 Kettle Falls Generator Out of Step

The Kettle Falls generator can become unstable if a time delayed three phase fault occurs on the Addy – Kettle Falls 115kV Transmission Line near Addy. Studies indicate that speeding up the Zone 2 clearing (time delay of 9 cycles, 13 cycles total clearing) is not sufficient to correct this out of step issue.

The stability issue was addressed with the installation of an out of step relay (78) at Kettle Falls. The transient stability results are shown below and indicate that the local system returns to a stable state once the generators are tripped offline.

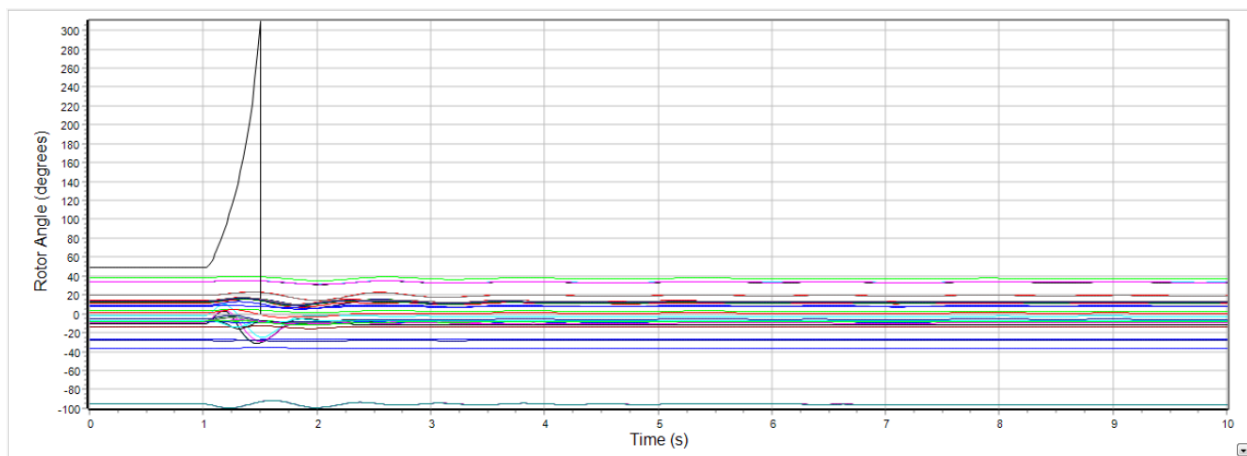

FIGURE 3: KETTLE FALLS GENERATION OOS.

Implementing a high speed communication aided tripping scheme on the Addy – Kettle Falls 115kV Transmission Line to improve stability performance of the Kettle Falls generation is necessary.

### 3.2 Nine Mile Generators Out of Step

All Nine Mile Hydro generators can become unstable if a time delayed three phase fault occurs on the Nine Mile – Westside 115kV Transmission Line near Westside. Studies indicate that speeding up the Zone 2 clearing (time delay of 9 cycles, 13 cycles total clearing) is not sufficient to correct this out of step issue.

Units #3 and #4 at Nine Mile Hydro have recently been rebuilt, resulting in up to 28MW of total facility generation. These units were commissioned with an out of step relay (78), but units #1 and #2 do not have this protection. The transient stability results are shown below and indicate that the local system returns to a stable state once units #1 and #2 are tripped offline.

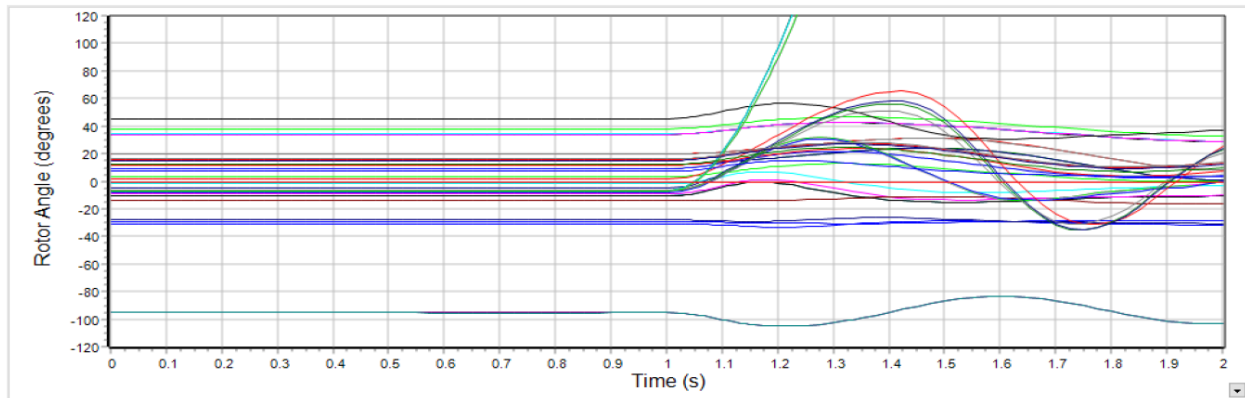

FIGURE 4: NINE MILE GENERATION OOS.

This issue is corrected after the Nine Mile - Westside 115kV Transmission Line is moved to the new Westside Southeast 115kV bus and the planned communication aided tripping is integrated.

### 3.3 Coeur d'Alene Area Voltage Recovery

During moderate to heavy loading, the Coeur d'Alene area has slow voltage recovery for a fault on the double circuit Boulder – Rathdrum and Lancaster – Rathdrum 230kV transmission lines (P7 contingency). The slow voltage recovery does not meet the WR1.1.4 Part 2 performance criteria as shown in Figure 5. Previous technical studies did not demonstrate the same performance. The implementation of stalled motor modeling in the composite load model contributes to the slow voltage recovery. Further detailed analysis is necessary to determine the accuracy of the simulation and potential modeling improvements. The implementation of the Coeur d'Alene System Reinforcement Project will address the voltage dip performance by improving the strength of the local transmission system.

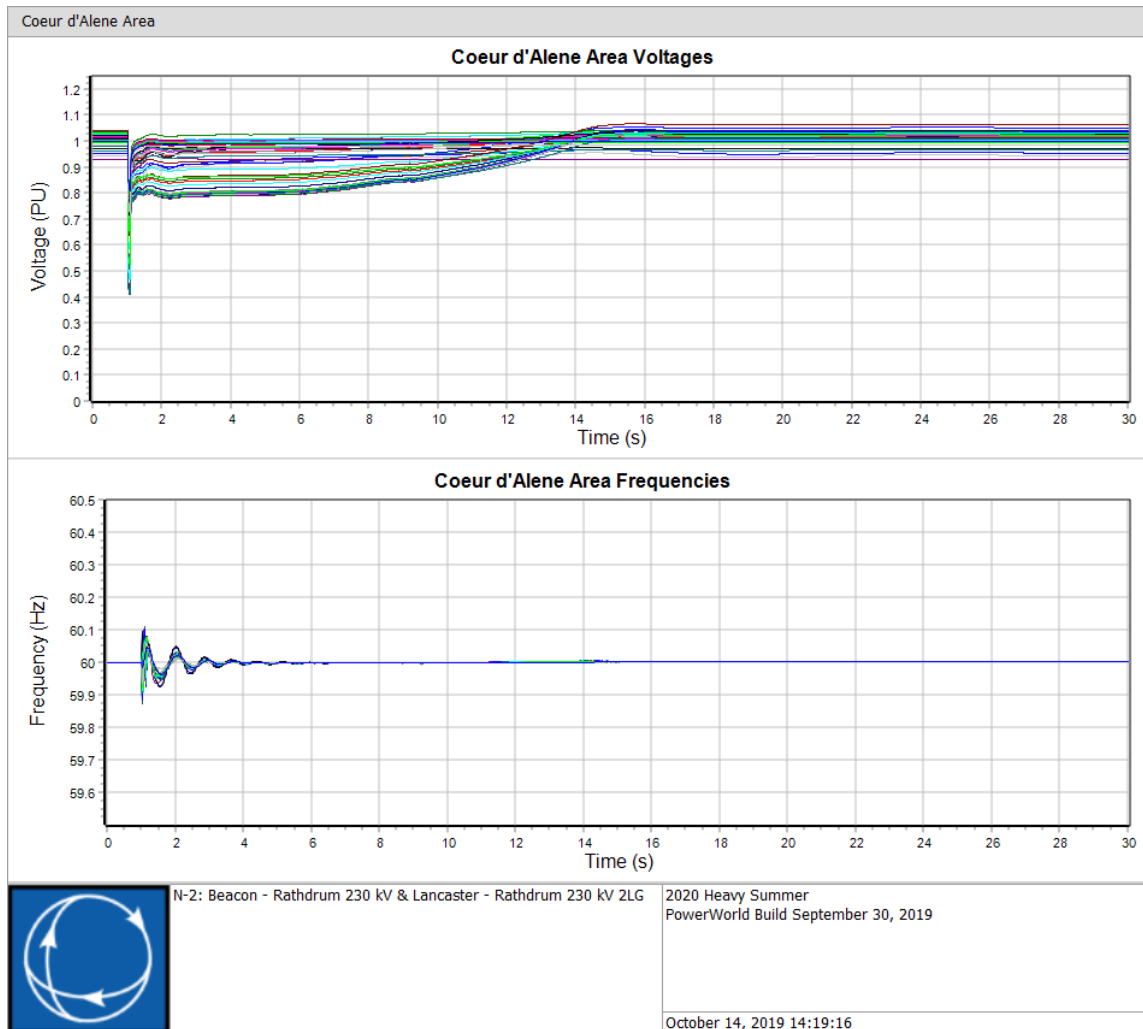

FIGURE 5: P7 CONTINGENCY VOLTAGE RECOVERY IN COEUR D'ALENE AREA.

## 5 SPARE EQUIPMENT ANALYSIS

Avista's 230/115kV transformer spare equipment strategy could result in the unavailability of these units for one year or more due to replacement lead time. The impact of a single transformer out of service and subsequent P0, P1 and P2 contingencies was studied by area.

### 5.1 Big Bend Area

Avista does not currently have any 230/115kV autotransformers, in service, in the Big Bend area.

### 5.2 Coeur d'Alene Area Transformers

Outage of either Rathdrum 230/115kV transformer may result in area overloads and low voltage problems for Rathdrum 115kV bus outages or the other Rathdrum transformer outage.

The Coeur d'Alene System Reinforcement Project has been identified for this purpose and will mitigate the bus issues.

Upgrading the existing #1 transformer, previously identified by Asset Management, will provide overload mitigation for some contingencies.

Additional analysis is required for mitigation of the double transformer outage.

### 5.3 Lewiston/Clarkston Area Transformers

Area transformer outages may result in overloads on the Lolo 230/115kV transformers. Area 115kV bus outages may result in area low voltage.

The Lolo Transformer Replacement Project Committed and Planned for completion by 2023 will mitigate the transformer overload problem.

Area low voltage mitigation will require further study.

### 5.4 Palouse Area Transformers

Outage of either the Moscow or Shawnee 230/115kV transformer may result in area low voltage and 115kV line overloads; outage of both transformers increases the severity.

The Palouse Area Reinforcement Project has been identified for this purpose.

### 5.5 Spokane Area Transformers

Outage of either Beacon 230/115kV transformer combined with an outage of either of the Boulder or Westside 230/115kV transformers may result in overload the Bell#6 230/115kV transformer. Additional instances of the Bell#6 transformer overloading as well area transformer overloading may occur for Beacon 230 and 115kV bus outages.

Upgrading of the BPA Bell#6 230/115kV transformer will mitigate the overload issues.

The South Spokane System Reinforcement Project has been identified for this purpose.

Additional analysis for an area solution is still required.

Detail results are presented in Appendix D.

## 6 SHORT CIRCUIT ANALYSIS

Sunset Substation was previously identified as having available short circuit current above the interrupting capability of at least one of the circuit breakers. No additional violations were identified in this year's assessment.

The Sunset Substation Rebuild Project is Committed and Planned for completion by 2023 which will mitigate this problem.

Detailed results are presented in Appendix E.

## 8 FEEDER CAPACITY ANALYSIS

Feeder Capacity analysis was done for feeders that have SCADA data available. Table 3 is a list of the 20 heaviest loaded feeders from the three year period 2016-2018. The peak represents the highest five minute average for the season- summer or winter. Seasonal Capacity is the SCADA Variable Limit for 0°C and 40°C ambient temperatures. Project planned indicates whether a project has been considered, planned, or under construction. It should be noted that peak values are taken without regard to system status.

Detailed results are presented in Appendix H.

Peak Feeder Loading (2016-2018)						
Feeder Name	Summer Peak Load (Amps)	Winter Peak Load (Amps)	Summer Capacity Limit (Amps)	Winter Capacity Limit (Amps)	Max Usage	Project Planned
WAK12F4	504	316	512	668	99%	Yes
ROS12F1	481	521	499	571	96%	
HUE142	493	325	512	613	96%	Yes
F&C12F2	468	318	512	668	91%	
NRC352	84	103	113	113	91%	
ODN731	284	297	312	456	91%	
COB12F1	463	343	512	668	90%	Yes
DAL132	462	262	512	668	90%	Yes
SE12F3	368	596	512	668	89%	Yes
ORI12F3	111	266	208	302	88%	
KET12F2	258	264	293	430	88%	
AIR12F2	427	435	485	668	88%	Yes
C&W12F6	446	355	512	608	87%	
DAL131	522	402	601	668	87%	Yes
LOL1359	356	258	413	635	86%	
SE12F2	516	502	601	668	86%	Yes
MEA12F1	440	284	512	668	86%	Yes
GLN12F2	440	398	512	668	86%	
APW112	477	436	557	618	86%	
F&C12F4	438	321	512	668	86%	

TABLE 3 PEAK FEEDER LOADING (2016-2018)

# APPENDIX A - AVISTA GENERAL INFORMATION

## A.1 GENERATION RESOURCES

Avista has a diverse mix of generation with a majority of its generation being hydro power based on various projects located on the Spokane River and Clark Fork River. Avista owns eight hydroelectric generating plants as well as coal (partial ownership), natural gas, and wood-waste combustion plants in five eastern Washington, northern Idaho, eastern Oregon, and eastern Montana locations. Avista also utilizes power supply purchase and sale arrangements of varying lengths to meet a portion of its load requirements. Table 4 through Table 6 summarize the operational capacities of Avista generating projects.

TABLE 4: AVISTA HYDROELECTRIC GENERATION RESOURCES.

Project Name	Fuel	Location	Area	Project Start Date	Maximum Capability (MW) <sup>F</sup>
Monroe Street	Spokane River	Spokane, WA	Spokane	1890	15.0
Post Falls	Spokane River	Post Falls, ID	CdA	1906	18.0
Nine Mile	Spokane River	Nine Mile Falls, WA	Spokane	1925	32.0
Little Falls	Spokane River	Ford, WA	Big Bend	1910	35.2
Long Lake	Spokane River	Ford, WA	Big Bend	1915	89.0
Upper Falls	Spokane River	Spokane, WA	Spokane	1922	10.2
Cabinet Gorge	Clark Fork River	Clark Fork, ID	CdA	1952	270.5
Noxon Rapids	Clark Fork River	Noxon, MT	CdA	1959	610.0
Total					1079.9

TABLE 5: AVISTA RENEWABLE GENERATION RESOURCES.

Project Name	Fuel	Location	Area	Project Start Date	Maximum Capability (MW) <sup>F</sup>
Palouse	Wind	Thornton, WA	Palouse	2012	104.0
Adams Neilson	Solar	Lind, WA	Big Bend	2018	19.2
Total					123.2

TABLE 6: AVISTA THERMAL GENERATION RESOURCES.

Project Name	Fuel	Location	Area	Project Start Date	Maximum Capability (MW) <sup>F</sup>
Colstrip 3&4 (15%)	Coal	Colstrip, MT	N/A	1984	247.0
Rathdrum (CT)	Gas	Rathdrum, ID	CdA	1995	176.0
Northeast (CT)	Gas	Spokane, WA	Spokane	1978	66.0
Boulder Park (IC)	Gas	Spokane, WA	Spokane	2002	24.6
Coyote Springs 2 (CC)	Gas	Boardman, OR	N/A	2003	317.5
Kettle Falls	Wood	Kettle Falls, WA	Big Bend	1983	50.7
Kettle Falls (CT)	Gas	Kettle Falls, WA	Big Bend	2002	11.0
Total					892.8



For more information on Avista's generation, please refer to the 2017 Integrated Resource Plan.

## A.2 TRANSMISSION SYSTEM

Avista owns and operates a system of over 2,200 miles of electric transmission facilities which include approximately 685 miles of 230kV transmission lines and 1,527 miles of 115kV transmission lines. Figure 6 illustrates Avista's Transmission System within the region.



FIGURE 6 AVISTA TRANSMISSION LINE MAP

The Avista 230kV transmission lines are the backbone of Avista's Transmission System and consist of two networked systems centered near the Spokane/Coeur d'Alene area and the Lewiston/Clarkston area.

# APPENDIX B - TRANSMISSION MODELS

## B.1 PLANNING CASE DESCRIPTION

Avista's System Planning Group develops a set of base cases (Planning Cases) biannually to model its Transmission Planner and Planning Coordinator areas as well as the regional transmission system. The Planning Case development process outlined in the internal document ***TP-SPP-04 – Data for Power System Modeling and Analysis*** is used which includes using WECC approved base cases and applying steady state and dynamic data modifications as required to represent desired scenarios. The resulting Planning Cases represent a normal System condition (N-0). Planning Cases include the following:

- Existing facilities, new planned facilities and changes to existing facilities.
- Known outages of generation or transmission facilities with a duration of at greater than six months are represented. Presently, Avista does not have long duration planned outages.
- Forecasted real and reactive loads along with generation resources (supply or demand side) are modeled as described in ***TP-SPP-07 – Loads and Resources Data for Steady State and Dynamic Studies***.
- Known commitments for Firm Transmission Service and Interchange are incorporated. WECC Rated Paths are modeled with their published limits. Future commitments exceeding the limits of WECC Rated Paths are not presently studied.

The following scenarios were developed to represent various seasonal conditions:

- Heavy Summer – this is a typical summer peak scenario where the Avista Balancing Authority Area load is at peak. The local hydro generation is at mid-summer output levels, most thermal generation is on line, and moderate transfers are flowing into Avista's Balancing Authority Area. This scenario is limited by the summer thermal limits on various elements of the transmission system, which helps to identify where the system is near capacity.
- Light Summer – this is a typical summer night time scenario where the Avista Balancing Authority Area load is at a minimum.
- Heavy Winter – this is a typical winter peak scenario where the Avista Balancing Authority Area load is at peak. The local hydro generation is at late-winter output levels, most thermal generation is on line, and moderate transfers are flowing into Avista's Balancing Authority Area. This scenario represents Avista heaviest load conditions, but benefits from lower ambient temperature which increases the operating limits of the various elements of the Transmission System and power factors near unity.
- Light Winter – this is a typical winter night time scenario where the Avista Balancing Authority Area load is at a minimum.

- Light Spring – this is a typical late spring case that captures light loading conditions with high levels of generation. The local hydro generation is near full capacity due to spring runoff, local wind and solar generation is near full capacity, select thermal generation is off line for maintenance, and moderate transfers are flowing out of Avista’s Balancing Authority Area. This scenario is also limited by the summer thermal limits on various elements of the transmission system, which helps to identify where the system is near capacity, due to power transfer.
- High East to West Transfer – this is a typical late spring case that captures light loading conditions with high levels of generation east of Avista’s Balancing Authority Area. This scenario brings both West of Hatwai (Path 6) and Montana to Northwest (Path 8) up to their rated path limits. This scenario is also limited by the summer thermal limits on various elements of the transmission system, which helps to identify where the system is near capacity, due to power transfer.
- High West to East Transfer – this is a typical summer peak scenario where the Avista, Idaho Power and Northwestern Energy Balancing Authority Area load is near peak. The local hydro generation is at early-summer output levels, most thermal generation is off line, and moderate transfers are flowing across Avista’s Balancing Authority Area to the west. This scenario is limited by the summer thermal limits on various elements of the transmission system, which helps to identify where the system is near capacity.

# 2021 Electric Integrated Resource Plan

## Appendix H – New Resource Table for Transmission



## Appendix H

New Resource Table For Transmission

Resource	Note	Resource Location	POR	POD	Start	Stop	Capacity MW	Year Total
Wind		Montana	Colstrip/BPA or AVAT.NWMT	AVA.SYS	1/1/2023	Indefinite	100.0	100.0
Wind		Montana	Colstrip/BPA or AVAT.NWMT	AVA.SYS	1/1/2024	Indefinite	100.0	100.0
Kettle Falls		Kettle Falls, WA	AVA.SYS	AVA.SYS	1/1/2026	Indefinite	12.0	
Post Falls		Post Falls	AVA.SYS	AVA.SYS	1/1/2026	Indefinite	8.0	
Natural Gas Peaker		Rathdrum, WA	AVA.SYS	AVA.SYS	11/1/2026	Indefinite	211.0	231.0
Wind		Off-System	Colstrip/BPA or AVAT.NWMT	AVA.SYS	1/1/2028	Indefinite	100.0	100.0
Hydro		Mid-C	MIDC	AVA.SYS	1/1/2031	Indefinite	75.0	75.0
Rathdrum		Rathdrum, WA	AVA.SYS	AVA.SYS	1/1/2035	Indefinite	5.0	5.0
Natural Gas Peaker		TBD	AVA.SYS	AVA.SYS	1/1/2036	Indefinite	87.0	87.0
Solar & Storage	100 MW Solar w/ 50 MW Storage	TBD	AVA.SYS	AVA.SYS	1/1/2038	Indefinite	100.0	100.0
Wind		TBD	Colstrip/BPA or AVAT.NWMT	AVA.SYS	1/1/2041	Indefinite	100.0	
Natural Gas Peaker		TBD	AVA.SYS	AVA.SYS	1/1/2041	Indefinite	36.0	136.0
Solar & Storage	117 MW Solar w/ 58 MW Storage	TBD	AVA.SYS	AVA.SYS	1/1/2042	Indefinite	117.0	117.0
Solar & Storage	122 MW Solar w/ 61 MW Storage	TBD	AVA.SYS	AVA.SYS	1/1/2043	Indefinite	122.0	122.0
Storage	Liquid Air	TBD	AVA.SYS	AVA.SYS	1/1/2044	Indefinite	12.0	12.0
Solar & Storage	149 MW Solar w/ 75 MW Storage	TBD	AVA.SYS	AVA.SYS	1/1/2045	Indefinite	149.0	
Storage	Liquid Air	TBD	AVA.SYS	AVA.SYS	1/1/2045	Indefinite	10.0	159.0

Total 1344.0 1344.0

# 2021 Electric Integrated Resource Plan

## Appendix I – Publicly Available Inputs and Models



## Appendix I Content

The Company makes data input files in native format, models, and other various content used for its Integrated Resource Planning process available to stakeholders. Non-confidential, non-proprietary IRP content can also be found at [Integrated Resource Planning \(myavista.com\)](https://myavista.com). In a manner to further increase transparency and provide clarity for stakeholders, the following table provides context on data files, models and other content included in Appendix I.

File Name	Folder	File Type	Description of Content
DR Model Avista Integrated Opt-In 3_1_21	Demand Response	Excel	Final AEG model for opt-in demand response programs.
DR Model Avista Integrated Opt-Out 3_1_21	Demand Response	Excel	Final AEG model for opt-out demand response programs.
DR Model Avista Stand Alone 3_1_21	Demand Response	Excel	Final AEG model for stand-alone demand response programs.
Avista 2020 CPA – Electric EE Measure List	Energy Efficiency	Excel	List of residential, commercial and industrial energy efficiency measures along with an introduction includes instructions, notes and sources.
Avista 2020 Electric CPA – Summary and IRP Inputs_Draft_2	Energy Efficiency	Excel	Achievable technical potential energy savings, winter peak savings, summary peak savings inputs used in IRP.
Home Electrification Conversion	Load Forecast	Excel	Regression, assumptions and summary of home conversions if electrification were to occur and impacts to Avista’s electric system.
Load Forecast	Load Forecast	Excel	Energy forecast, peak forecast, retail sales, load split percentages, PHEV and customer rooftop solar.
Climate Shift Scenario Inputs	Market Modeling Inputs and Results	Excel	80-year regional hydro record from NPCC, NPCC 2024 economy load forecast with changing temperatures and factors used in the Aurora model.
CO2 Emissions by Year_Expected-Case	Market Modeling Inputs and Results	Excel	Regional CO2 emission by year for the expected case.
CO2 Emissions by Year_SCC	Market Modeling Inputs and Results	Excel	Regional CO2 emission by year for the social cost of carbon case.

High & Low Natural Gas Prices	Market Modeling Inputs and Results	Excel	High (95 <sup>th</sup> percentile) and low (25 <sup>th</sup> percentile) monthly natural gas prices for the IRP timeframe.
Market Modeling Results	Market Modeling Inputs and Results	Excel	Market modeling results to include stochastic off-peak/on-peak/flat Mid-C prices, stochastic greenhouse gas, hourly Mid-C prices, stochastic historical regional resource dispatch, deterministic hourly Mid-C prices, deterministic monthly Mid-C prices scenarios, deterministic annual greenhouse gas emissions and deterministic regional resource dispatch.
Natural Gas Prices	Market Modeling Inputs and Results	Excel	Monthly natural gas price forecast used for the IRP, both stochastic and deterministic, as well as basin percentage spreads.
Regional Generation Analysis_ClimateShift_2021_IRP	Market Modeling Inputs and Results	Excel	Regional generation analysis by fuel type by state.
Regional Generation Analysis_Expected-Case_2021_IRP_Deterministic	Market Modeling Inputs and Results	Excel	Regional deterministic generation analysis by fuel type by state.
Regional Generation Analysis_Expected-Case_2021_IRP_Stochastic	Market Modeling Inputs and Results	Excel	Regional stochastic generation analysis by fuel type by state.
Regional Generation Analysis_HighPrice_2021_IRP	Market Modeling Inputs and Results	Excel	Regional generation analysis by fuel type by state using the high price scenario.
Regional Generation Analysis_LowPrice_2021_IRP	Market Modeling Inputs and Results	Excel	Regional generation analysis by fuel type by state using the low price scenario.
Regional Generation Analysis_SCC-Case_2021_IRP		Excel	Regional generation analysis by fuel type by state using the SCC scenario.
Social Cost of Carbon	Market Modeling Inputs and Results	Excel	Social cost of carbon in 2007 and 2019 dollars, nominal and levelized.
Emissions_Summary_073020	Other Files	Excel	Avista owned resource emissions summary for select years.



Named Populations	Other Files	Excel	State FIPS codes, county codes, socioeconomic and sensitive population ratings (1-10 with 10 being the highest degree), county, utility (specific to Avista).
Upstream Emission Calculation	Other Files	Excel	Upstream emission calculation for gas and power supply methods as well as method in practice.
1_PriSM_7.0_GUROBI_120720_IRP_PRS_DRAFT_Deterministic	PriSM Model Files- Portfolio Scenarios	Excel	PriSM model - must have Gurobi license to run. Least reasonable cost, PRS, deterministic scenario. Includes a summary of resource selected, financial summary, clean goal progress, loads & resources, demand response, resource data, energy efficiency selected, Aurora resource results, transmission annual revenue requirement from amortization model, annual cost of resource options, resources (MWh), hydro & contracts market value, stochastic variable cost of risk, general assumptions, regional emissions, conservation load value (\$/MW) and new CapEx.
1_PriSM_7.0_GUROBI_120720_IRP_PRS_DRAFT_HighNGPrice	PriSM Model Files- Portfolio Scenarios	Excel	PriSM model - must have Gurobi license to run. Least reasonable cost, PRS, high natural gas price scenario. Includes a summary of resource selected, financial summary, clean goal progress, loads & resources, demand response, resource data, energy efficiency selected, Aurora resource results, transmission annual revenue requirement from amortization model, annual cost of resource options, resources (MWh), hydro & contracts market value, stochastic variable cost of risk, general assumptions, regional emissions, conservation load value (\$/MW) and new CapEx.
1_PriSM_7.0_GUROBI_120720_IRP_PRS_DRAFT_LowNGPrice	PriSM Model Files- Portfolio Scenarios	Excel	PriSM model - must have Gurobi license to run. Least reasonable cost, PRS, low natural gas price scenario. Includes a summary of resource selected, financial summary, clean goal progress, loads &

			resources, demand response, resource data, energy efficiency selected, Aurora resource results, transmission annual revenue requirement from amortization model, annual cost of resource options, resources (MWh), hydro & contracts market value, stochastic variable cost of risk, general assumptions, regional emissions, conservation load value (\$/MW) and new CapEx.
1_PriSM_7.0_GUROBI_120720_IRP_PRS_DRAFT_SCC	PRiSM Model Files- Portfolio Scenarios	Excel	PRiSM model - must have Gurobi license to run. Least reasonable cost, PRS, social cost of carbon scenario. Includes a summary of resource selected, financial summary, clean goal progress, loads & resources, demand response, resource data, energy efficiency selected, Aurora resource results, transmission annual revenue requirement from amortization model, annual cost of resource options, resources (MWh), hydro & contracts market value, stochastic variable cost of risk, general assumptions, regional emissions, conservation load value (\$/MW) and new CapEx.
1a_PriSM_7.0_GUROBI_120720_IRP_PRS_DRAFT_ClimateShift	PRiSM Model Files- Portfolio Scenarios	Excel	PRiSM model - must have Gurobi license to run. Climate shift scenario, deterministic study, re-optimized. Includes a summary of resource selected, financial summary, clean goal progress, loads & resources, demand response, resource data, energy efficiency selected, Aurora resource results, transmission annual revenue requirement from amortization model, annual cost of resource options, resources (MWh), hydro & contracts market value, stochastic variable cost of risk, general assumptions, regional emissions, conservation load value (\$/MW) and new CapEx.

1b_PriSM_7.0_GUROBI_120720_IRP_PRS_DRAFT_SCC	PRiSM Model Files- Portfolio Scenarios	Excel	PRiSM model - must have Gurobi license to run. Least reasonable cost, PRS, social cost of carbon scenario, re-optimized for SCC. Includes a summary of resource selected, financial summary, clean goal progress, loads & resources, demand response, resource data, energy efficiency selected, Aurora resource results, transmission annual revenue requirement from amortization model, annual cost of resource options, resources (MWh), hydro & contracts market value, stochastic variable cost of risk, general assumptions, regional emissions, conservation load value (\$/MW) and new CapEx.
3_PriSM_7.0_GUROBI_120720_IRP_PRS_DRAFT_Deterministic	PRiSM Model Files- Portfolio Scenarios	Excel	PRiSM model - must have Gurobi license to run. Baseline 2 portfolio, deterministic. Includes a summary of resource selected, financial summary, clean goal progress, loads & resources, demand response, resource data, energy efficiency selected, Aurora resource results, transmission annual revenue requirement from amortization model, annual cost of resource options, resources (MWh), hydro & contracts market value, stochastic variable cost of risk, general assumptions, regional emissions, conservation load value (\$/MW) and new CapEx.
3_PriSM_7.0_GUROBI_120720_IRP_PRS_DRAFT_HighNGPrice	PRiSM Model Files- Portfolio Scenarios	Excel	PRiSM model - must have Gurobi license to run. Baseline 2 portfolio, high gas price scenario. Includes a summary of resource selected, financial summary, clean goal progress, loads & resources, demand response, resource data, energy efficiency selected, Aurora resource results, transmission annual revenue requirement from amortization model, annual cost of resource options, resources (MWh), hydro & contracts market value, stochastic

			variable cost of risk, general assumptions, regional emissions, conservation load value (\$/MW) and new CapEx.
3_PriSM_7.0_GUROBI_120720_IRP_PRS_DRAFT_LowNGPrice	PriSM Model Files- Portfolio Scenarios	Excel	PriSM model - must have Gurobi license to run. Baseline 2 portfolio, low gas price scenario. Includes a summary of resource selected, financial summary, clean goal progress, loads & resources, demand response, resource data, energy efficiency selected, Aurora resource results, transmission annual revenue requirement from amortization model, annual cost of resource options, resources (MWh), hydro & contracts market value, stochastic variable cost of risk, general assumptions, regional emissions, conservation load value (\$/MW) and new CapEx.
3_PriSM_7.0_GUROBI_120720_IRP_PRS_DRAFT_SCC	PriSM Model Files- Portfolio Scenarios	Excel	PriSM model - must have Gurobi license to run. Baseline 2 portfolio, social cost of carbon scenario. Includes a summary of resource selected, financial summary, clean goal progress, loads & resources, demand response, resource data, energy efficiency selected, Aurora resource results, transmission annual revenue requirement from amortization model, annual cost of resource options, resources (MWh), hydro & contracts market value, stochastic variable cost of risk, general assumptions, regional emissions, conservation load value (\$/MW) and new CapEx.
5_PriSM_7.0_GUROBI_120720_IRP_PRS_DRAFT_Deterministic	PriSM Model Files- Portfolio Scenarios	Excel	PriSM model - must have Gurobi license to run. 2027 clean resource plan, add clean energy resources to = 100% retail sales, deterministic scenario. Includes a summary of resource selected, financial summary, clean goal progress, loads & resources, demand response, resource data, energy

			<p>efficiency selected, Aurora resource results, transmission annual revenue requirement from amortization model, annual cost of resource options, resources (MWh), hydro &amp; contracts market value, stochastic variable cost of risk, general assumptions, regional emissions, conservation load value (\$/MW) and new CapEx.</p>
<p>5_PRiSM_7.0_GUROBI_120720_IRP_PRS_DRAFT_HighNGPrice</p>	<p>PRiSM Model Files- Portfolio Scenarios</p>	<p>Excel</p>	<p>PRiSM model - must have Gurobi license to run. 2027 clean resource plan, add clean energy resources to = 100% retail sales, high natural gas price scenario. Includes a summary of resource selected, financial summary, clean goal progress, loads &amp; resources, demand response, resource data, energy efficiency selected, Aurora resource results, transmission annual revenue requirement from amortization model, annual cost of resource options, resources (MWh), hydro &amp; contracts market value, stochastic variable cost of risk, general assumptions, regional emissions, conservation load value (\$/MW) and new CapEx.</p>
<p>5_PRiSM_7.0_GUROBI_120720_IRP_PRS_DRAFT_LowNGPrice</p>	<p>PRiSM Model Files- Portfolio Scenarios</p>	<p>Excel</p>	<p>PRiSM model - must have Gurobi license to run. 2027 clean resource plan, add clean energy resources to = 100% retail sales, low natural gas price scenario. Includes a summary of resource selected, financial summary, clean goal progress, loads &amp; resources, demand response, resource data, energy efficiency selected, Aurora resource results, transmission annual revenue requirement from amortization model, annual cost of resource options, resources (MWh), hydro &amp; contracts market value, stochastic variable cost of risk, general assumptions, regional emissions, conservation load value (\$/MW) and new CapEx.</p>

5_PRISM_7.0_GUROBI_120720_IRP_PRS_DRAFT_SCC	PRISM Model Files- Portfolio Scenarios	Excel	PRISM model - must have Gurobi license to run. 2027 clean resource plan, add clean energy resources to = 100% retail sales, social cost of carbon scenario. Includes a summary of resource selected, financial summary, clean goal progress, loads & resources, demand response, resource data, energy efficiency selected, Aurora resource results, transmission annual revenue requirement from amortization model, annual cost of resource options, resources (MWh), hydro & contracts market value, stochastic variable cost of risk, general assumptions, regional emissions, conservation load value (\$/MW) and new CapEx.
6_PRISM_7.0_GUROBI_120720_IRP_PRS_DRAFT_Deterministic	PRISM Model Files- Portfolio Scenarios	Excel	PRISM model - must have Gurobi license to run. 2045 clean resource plan, add clean energy resources to = 100% retail sales, no new thermal resource, existing thermal resource retire by 2044, long lake and cabinet upgrades turned on, deterministic scenario. Includes a summary of resource selected, financial summary, clean goal progress, loads & resources, demand response, resource data, energy efficiency selected, Aurora resource results, transmission annual revenue requirement from amortization model, annual cost of resource options, resources (MWh), hydro & contracts market value, stochastic variable cost of risk, general assumptions, regional emissions, conservation load value (\$/MW) and new CapEx.
6_PRISM_7.0_GUROBI_120720_IRP_PRS_DRAFT_HighNGPrice	PRISM Model Files- Portfolio Scenarios	Excel	PRISM model - must have Gurobi license to run. 2045 clean resource plan, add clean energy resources to = 100% retail sales, no new thermal resource, existing thermal resource retire by 2044, long lake and cabinet upgrades turned on, high

			natural gas price scenario. Includes a summary of resource selected, financial summary, clean goal progress, loads & resources, demand response, resource data, energy efficiency selected, Aurora resource results, transmission annual revenue requirement from amortization model, annual cost of resource options, resources (MWh), hydro & contracts market value, stochastic variable cost of risk, general assumptions, regional emissions, conservation load value (\$/MW) and new CapEx.
6_PRiSM_7.0_GUROBI_120720_IRP_PRS_DRAFT_LowNGPrice	PRiSM Model Files- Portfolio Scenarios	Excel	PRiSM model - must have Gurobi license to run. 2045 clean resource plan, add clean energy resources to = 100% retail sales, no new thermal resource, existing thermal resource retire by 2044, long lake and cabinet upgrades turned on, low natural gas price scenario. Includes a summary of resource selected, financial summary, clean goal progress, loads & resources, demand response, resource data, energy efficiency selected, Aurora resource results, transmission annual revenue requirement from amortization model, annual cost of resource options, resources (MWh), hydro & contracts market value, stochastic variable cost of risk, general assumptions, regional emissions, conservation load value (\$/MW) and new CapEx.
6_PRiSM_7.0_GUROBI_120720_IRP_PRS_DRAFT_SCC	PRiSM Model Files- Portfolio Scenarios	Excel	PRiSM model - must have Gurobi license to run. 2045 clean resource plan, add clean energy resources to = 100% retail sales, no new thermal resource, existing thermal resource retire by 2044, long lake and cabinet upgrades turned on, social cost of carbon scenario. Includes a summary of resource selected, financial summary, clean goal progress, loads & resources, demand response,

			resource data, energy efficiency selected, Aurora resource results, transmission annual revenue requirement from amortization model, annual cost of resource options, resources (MWh), hydro & contracts market value, stochastic variable cost of risk, general assumptions, regional emissions, conservation load value (\$/MW) and new CapEx.
15_PriSM_7.0_GUROBI_1207 20_IRP_PRS_DRAFT_Deterministic	PriSM Model Files- Portfolio Scenarios	Excel	PriSM model - must have Gurobi license to run. Colstrip retire 2025, deterministic scenario. Includes a summary of resource selected, financial summary, clean goal progress, loads & resources, demand response, resource data, energy efficiency selected, Aurora resource results, transmission annual revenue requirement from amortization model, annual cost of resource options, resources (MWh), hydro & contracts market value, stochastic variable cost of risk, general assumptions, regional emissions, conservation load value (\$/MW) and new CapEx.
15_PriSM_7.0_GUROBI_1207 20_IRP_PRS_DRAFT_HighNG Price	PriSM Model Files- Portfolio Scenarios	Excel	PriSM model - must have Gurobi license to run. Colstrip retire 2025, high natural gas price scenario. Includes a summary of resource selected, financial summary, clean goal progress, loads & resources, demand response, resource data, energy efficiency selected, Aurora resource results, transmission annual revenue requirement from amortization model, annual cost of resource options, resources (MWh), hydro & contracts market value, stochastic variable cost of risk, general assumptions, regional emissions, conservation load value (\$/MW) and new CapEx.



15_PriSM_7.0_GUROBI_1207 20_IRP_PRS_DRAFT_LowNGP rice	PRiSM Model Files- Portfolio Scenarios	Excel	PRiSM model - must have Gurobi license to run. Colstrip retire 2025, low natural gas price scenario. Includes a summary of resource selected, financial summary, clean goal progress, loads & resources, demand response, resource data, energy efficiency selected, Aurora resource results, transmission annual revenue requirement from amortization model, annual cost of resource options, resources (MWh), hydro & contracts market value, stochastic variable cost of risk, general assumptions, regional emissions, conservation load value (\$/MW) and new CapEx.
15_PriSM_7.0_GUROBI_1207 20_IRP_PRS_DRAFT_SCC	PRiSM Model Files- Portfolio Scenarios	Excel	PRiSM model - must have Gurobi license to run. Colstrip retire 2025, social cost of carbon scenario. Includes a summary of resource selected, financial summary, clean goal progress, loads & resources, demand response, resource data, energy efficiency selected, Aurora resource results, transmission annual revenue requirement from amortization model, annual cost of resource options, resources (MWh), hydro & contracts market value, stochastic variable cost of risk, general assumptions, regional emissions, conservation load value (\$/MW) and new CapEx.
16_PriSM_7.0_GUROBI_1207 20_IRP_PRS_DRAFT_Determin istic	PRiSM Model Files- Portfolio Scenarios	Excel	PRiSM model - must have Gurobi license to run. Colstrip retire 2035, deterministic scenario. Includes a summary of resource selected, financial summary, clean goal progress, loads & resources, demand response, resource data, energy efficiency selected, Aurora resource results, transmission annual revenue requirement from amortization model, annual cost of resource options, resources (MWh), hydro & contracts market value, stochastic variable

			cost of risk, general assumptions, regional emissions, conservation load value (\$/MW) and new CapEx.
16_PriSM_7.0_GUROBI_1207 20_IRP_PRS_DRAFT_HighNG Price	PriSM Model Files- Portfolio Scenarios	Excel	PriSM model - must have Gurobi license to run. Colstrip retire 2035, high natural gas price scenario. Includes a summary of resource selected, financial summary, clean goal progress, loads & resources, demand response, resource data, energy efficiency selected, Aurora resource results, transmission annual revenue requirement from amortization model, annual cost of resource options, resources (MWh), hydro & contracts market value, stochastic variable cost of risk, general assumptions, regional emissions, conservation load value (\$/MW) and new CapEx.
16_PriSM_7.0_GUROBI_1207 20_IRP_PRS_DRAFT_LowNGP rice	PriSM Model Files- Portfolio Scenarios	Excel	PriSM model - must have Gurobi license to run. Colstrip retire 2035, low natural gas price scenario. Includes a summary of resource selected, financial summary, clean goal progress, loads & resources, demand response, resource data, energy efficiency selected, Aurora resource results, transmission annual revenue requirement from amortization model, annual cost of resource options, resources (MWh), hydro & contracts market value, stochastic variable cost of risk, general assumptions, regional emissions, conservation load value (\$/MW) and new CapEx.
16_PriSM_7.0_GUROBI_1207 20_IRP_PRS_DRAFT_SCC	PriSM Model Files- Portfolio Scenarios	Excel	PriSM model - must have Gurobi license to run. Colstrip retire 2035, social cost of carbon scenario. Includes a summary of resource selected, financial summary, clean goal progress, loads & resources, demand response, resource data, energy efficiency selected, Aurora resource results, transmission

			annual revenue requirement from amortization model, annual cost of resource options, resources (MWh), hydro & contracts market value, stochastic variable cost of risk, general assumptions, regional emissions, conservation load value (\$/MW) and new CapEx.
17_PriSM_7.0_GUROBI_1207 20_IRP_PRS_DRAFT_Deterministic	PriSM Model Files- Portfolio Scenarios	Excel	PriSM model - must have Gurobi license to run. Colstrip retire 2045, deterministic scenario. Includes a summary of resource selected, financial summary, clean goal progress, loads & resources, demand response, resource data, energy efficiency selected, Aurora resource results, transmission annual revenue requirement from amortization model, annual cost of resource options, resources (MWh), hydro & contracts market value, stochastic variable cost of risk, general assumptions, regional emissions, conservation load value (\$/MW) and new CapEx.
17_PriSM_7.0_GUROBI_1207 20_IRP_PRS_DRAFT_HighNG Price	PriSM Model Files- Portfolio Scenarios	Excel	PriSM model - must have Gurobi license to run. Colstrip retire 2045, high natural gas price scenario. Includes a summary of resource selected, financial summary, clean goal progress, loads & resources, demand response, resource data, energy efficiency selected, Aurora resource results, transmission annual revenue requirement from amortization model, annual cost of resource options, resources (MWh), hydro & contracts market value, stochastic variable cost of risk, general assumptions, regional emissions, conservation load value (\$/MW) and new CapEx.
17_PriSM_7.0_GUROBI_1207 20_IRP_PRS_DRAFT_LowNGP rice	PriSM Model Files- Portfolio Scenarios	Excel	PriSM model - must have Gurobi license to run. Colstrip retire 2045, low natural gas price scenario. Includes a summary of resource selected, financial

			summary, clean goal progress, loads & resources, demand response, resource data, energy efficiency selected, Aurora resource results, transmission annual revenue requirement from amortization model, annual cost of resource options, resources (MWh), hydro & contracts market value, stochastic variable cost of risk, general assumptions, regional emissions, conservation load value (\$/MW) and new CapEx.
17_PriSM_7.0_GUROBI_1207 20_IRP_PRS_DRAFT_SCC	PriSM Model Files- Portfolio Scenarios	Excel	PriSM model - must have Gurobi license to run. Colstrip retire 2045, social cost of carbon scenario. Includes a summary of resource selected, financial summary, clean goal progress, loads & resources, demand response, resource data, energy efficiency selected, Aurora resource results, transmission annual revenue requirement from amortization model, annual cost of resource options, resources (MWh), hydro & contracts market value, stochastic variable cost of risk, general assumptions, regional emissions, conservation load value (\$/MW) and new CapEx.
1_PriSM_7.0_GUROBI_12072 0_IRP_PRS	PriSM Model Files- Portfolio Studies	Excel	PriSM model - must have Gurobi license to run. Least reasonable cost. preferred resource strategy. Includes a summary of resource selected, financial summary, clean goal progress, loads & resources, demand response, resource data, energy efficiency selected, Aurora resource results, transmission annual revenue requirement from amortization model, annual cost of resource options, resources (MWh), hydro & contracts market value, stochastic variable cost of risk, general assumptions, regional emissions, conservation load value (\$/MW) and new CapEx.

2_PriSM_7.0_GUROBI_12072 0_IRP_Baseline1	PRiSM Model Files- Portfolio Studies	Excel	PRiSM model - must have Gurobi license to run. Baseline 1, removes clean energy targets in Washington. Includes a summary of resource selected, financial summary, clean goal progress, loads & resources, demand response, resource data, energy efficiency selected, Aurora resource results, transmission annual revenue requirement from amortization model, annual cost of resource options, resources (MWh), hydro & contracts market value, stochastic variable cost of risk, general assumptions, regional emissions, conservation load value (\$/MW) and new CapEx.
3_PriSM_7.0_GUROBI_12072 0_IRP_Baseline2	PRiSM Model Files- Portfolio Studies	Excel	PRiSM model - must have Gurobi license to run. Baseline 2, no clean goal, no SCC, EE held constant, existing resources held constant, remove flex plant as option due to size even though it's preferred. Includes a summary of resource selected, financial summary, clean goal progress, loads & resources, demand response, resource data, energy efficiency selected, Aurora resource results, transmission annual revenue requirement from amortization model, annual cost of resource options, resources (MWh), hydro & contracts market value, stochastic variable cost of risk, general assumptions, regional emissions, conservation load value (\$/MW) and new CapEx.
4_PriSM_7.0_GUROBI_12072 0_IRP_Baseline3	PRiSM Model Files- Portfolio Studies	Excel	PRiSM model - must have Gurobi license to run. Baseline 3, no clean goal, no SCC, EE held constant, existing resources held constant. Includes a summary of resource selected, financial summary, clean goal progress, loads & resources, demand response, resource data, energy efficiency selected, Aurora resource results, transmission annual

			revenue requirement from amortization model, annual cost of resource options, resources (MWh), hydro & contracts market value, stochastic variable cost of risk, general assumptions, regional emissions, conservation load value (\$/MW) and new CapEx.
5_PriSM_7.0_GUROBI_120720_IRP_2027 CRP	PriSM Model Files- Portfolio Studies	Excel	PriSM model - must have Gurobi license to run. 2027 clean resource plan, add clean energy resources to = 100% retail sales. Includes a summary of resource selected, financial summary, clean goal progress, loads & resources, demand response, resource data, energy efficiency selected, Aurora resource results, transmission annual revenue requirement from amortization model, annual cost of resource options, resources (MWh), hydro & contracts market value, stochastic variable cost of risk, general assumptions, regional emissions, conservation load value (\$/MW) and new CapEx.
6_PriSM_7.0_GUROBI_120720_IRP_2045 CRP	PriSM Model Files- Portfolio Studies	Excel	PriSM model - must have Gurobi license to run. 2045 clean resource plan, add clean energy resources to = 100% retail sales, no new thermal resource, existing thermal resource retire by 2044, long lake and cabinet upgrades turned on. Includes a summary of resource selected, financial summary, clean goal progress, loads & resources, demand response, resource data, energy efficiency selected, Aurora resource results, transmission annual revenue requirement from amortization model, annual cost of resource options, resources (MWh), hydro & contracts market value, stochastic variable cost of risk, general assumptions, regional

			emissions, conservation load value (\$/MW) and new CapEx.
6b_PriSM_7.0_GUROBI_1207 20_IRP_2045 CRP	PriSM Model Files- Portfolio Studies	Excel	PriSM model - must have Gurobi license to run. 2045 clean resource plan, add clean energy resources to = 100%, Colstrip exits in 2022 retail sales, no new thermal resource, existing thermal resource retire by 2044, long lake and cabinet upgrades turned on. Includes a summary of resource selected, financial summary, clean goal progress, loads & resources, demand response, resource data, energy efficiency selected, Aurora resource results, transmission annual revenue requirement from amortization model, annual cost of resource options, resources (MWh), hydro & contracts market value, stochastic variable cost of risk, general assumptions, regional emissions, conservation load value (\$/MW) and new CapEx.
7_PriSM_7.0_GUROBI_12072 0_IRP_SCC Applied to ID	PriSM Model Files- Portfolio Studies	Excel	PriSM model - must have Gurobi license to run. Social cost of carbon applied to Idaho, EE held constant. Includes a summary of resource selected, financial summary, clean goal progress, loads & resources, demand response, resource data, energy efficiency selected, Aurora resource results, transmission annual revenue requirement from amortization model, annual cost of resource options, resources (MWh), hydro & contracts market value, stochastic variable cost of risk, general assumptions, regional emissions, conservation load value (\$/MW) and new CapEx.
8_PriSM_7.0_GUROBI_12072 0_IRP_Low Load Forecast	PriSM Model Files- Portfolio Studies	Excel	PriSM model - must have Gurobi license to run. Low load forecast scenario, EE held constant from PRS. Includes a summary of resource selected, financial summary, clean goal progress, loads &

			resources, demand response, resource data, energy efficiency selected, Aurora resource results, transmission annual revenue requirement from amortization model, annual cost of resource options, resources (MWh), hydro & contracts market value, stochastic variable cost of risk, general assumptions, regional emissions, conservation load value (\$/MW) and new CapEx.
9_PRISM_7.0_GUROBI_120720_IRP_High Load Forecast	PRISM Model Files- Portfolio Studies	Excel	PRISM model - must have Gurobi license to run. High load forecast scenario, EE held constant from PRS. Includes a summary of resource selected, financial summary, clean goal progress, loads & resources, demand response, resource data, energy efficiency selected, Aurora resource results, transmission annual revenue requirement from amortization model, annual cost of resource options, resources (MWh), hydro & contracts market value, stochastic variable cost of risk, general assumptions, regional emissions, conservation load value (\$/MW) and new CapEx.
10_PRISM_7.0_GUROBI_120720_RA Market	PRISM Model Files- Portfolio Studies	Excel	PRISM model - must have Gurobi license to run. Resource adequacy market scenario, uses RA market planning requirements rather than Avista's, includes change to existing resources and changes to peak credits for new resources. Includes a summary of resource selected, financial summary, clean goal progress, loads & resources, demand response, resource data, energy efficiency selected, Aurora resource results, transmission annual revenue requirement from amortization model, annual cost of resource options, resources (MWh), hydro & contracts market value, stochastic variable cost of risk, general assumptions, regional



			emissions, conservation load value (\$/MW) and new CapEx.
11_PriSM_7.0_GUROBI_1207 20_IRP_Electirication 1	PriSM Model Files- Portfolio Studies	Excel	PriSM model - must have Gurobi license to run. Electrification scenario 1, forecast of additional load due to natural gas customers moving to electric, uses Avista forecast on load changes, updates EE programs & DR for additional opportunities, adjustments made to load value & retail sales. Includes a summary of resource selected, financial summary, clean goal progress, loads & resources, demand response, resource data, energy efficiency selected, Aurora resource results, transmission annual revenue requirement from amortization model, annual cost of resource options, resources (MWh), hydro & contracts market value, stochastic variable cost of risk, general assumptions, regional emissions, conservation load value (\$/MW) and new CapEx.
12_PriSM_7.0_GUROBI_1207 20_IRP_Electirication 2	PriSM Model Files- Portfolio Studies	Excel	PriSM model - must have Gurobi license to run. Electrification scenario 2 – hybrid scenario, forecast of additional load due to natural gas customers moving to electric, uses Avista forecast on load changes, updates EE programs & DR for additional opportunities, adjustments made to load value & retail sales. Includes a summary of resource selected, financial summary, clean goal progress, loads & resources, demand response, resource data, energy efficiency selected, Aurora resource results, transmission annual revenue requirement from amortization model, annual cost of resource options, resources (MWh), hydro & contracts market value, stochastic variable cost of risk, general

			assumptions, regional emissions, conservation load value (\$/MW) and new CapEx.
13_PriSM_7.0_GUROBI_1207 20_IRP_Electirication 3	PriSM Model Files- Portfolio Studies	Excel	PriSM model - must have Gurobi license to run. Electrification scenario 3 – high efficiency, forecast of additional load due to natural gas customers moving to electric, uses Avista forecast on load changes, updates EE programs & DR for additional opportunities, adjustments made to load value & retail sales. Includes a summary of resource selected, financial summary, clean goal progress, loads & resources, demand response, resource data, energy efficiency selected, Aurora resource results, transmission annual revenue requirement from amortization model, annual cost of resource options, resources (MWh), hydro & contracts market value, stochastic variable cost of risk, general assumptions, regional emissions, conservation load value (\$/MW) and new CapEx.
14_PriSM_7.0_GUROBI_1207 20_IRP_2xSCC	PriSM Model Files- Portfolio Studies	Excel	PriSM model - must have Gurobi license to run. Social cost of carbon times 2, doubles SCC for Washington – least cost strategy with this assumption. Includes a summary of resource selected, financial summary, clean goal progress, loads & resources, demand response, resource data, energy efficiency selected, Aurora resource results, transmission annual revenue requirement from amortization model, annual cost of resource options, resources (MWh), hydro & contracts market value, stochastic variable cost of risk, general assumptions, regional emissions, conservation load value (\$/MW) and new CapEx.

15_PriSM_7.0_GUROBI_1207 20_IRP_Colstrip2025	PRiSM Model Files- Portfolio Studies	Excel	PRiSM model - must have Gurobi license to run. Colstrip retire in 2025. Includes a summary of resource selected, financial summary, clean goal progress, loads & resources, demand response, resource data, energy efficiency selected, Aurora resource results, transmission annual revenue requirement from amortization model, annual cost of resource options, resources (MWh), hydro & contracts market value, stochastic variable cost of risk, general assumptions, regional emissions, conservation load value (\$/MW) and new CapEx.
16_PriSM_7.0_GUROBI_1207 20_IRP_Colstrip2035	PRiSM Model Files- Portfolio Studies	Excel	PRiSM model - must have Gurobi license to run. Colstrip retire in 2035. Includes a summary of resource selected, financial summary, clean goal progress, loads & resources, demand response, resource data, energy efficiency selected, Aurora resource results, transmission annual revenue requirement from amortization model, annual cost of resource options, resources (MWh), hydro & contracts market value, stochastic variable cost of risk, general assumptions, regional emissions, conservation load value (\$/MW) and new CapEx.
17_PriSM_7.0_GUROBI_1207 20_IRP_Colstrip2045	PRiSM Model Files- Portfolio Studies	Excel	PRiSM model - must have Gurobi license to run. Colstrip retire in 2045. Includes a summary of resource selected, financial summary, clean goal progress, loads & resources, demand response, resource data, energy efficiency selected, Aurora resource results, transmission annual revenue requirement from amortization model, annual cost of resource options, resources (MWh), hydro & contracts market value, stochastic variable cost of risk, general assumptions, regional emissions, conservation load value (\$/MW) and new CapEx.

18_PriSM_7.0_GUROBI_1207 20_IRP_2045 100 Delivered	PRiSM Model Files- Portfolio Studies	Excel	PRiSM model - must have Gurobi license to run. Not optimized, add clean resources and storage to meet delivery to load requirements. Includes a summary of resource selected, financial summary, clean goal progress, loads & resources, demand response, resource data, energy efficiency selected, Aurora resource results, transmission annual revenue requirement from amortization model, annual cost of resource options, resources (MWh), hydro & contracts market value, stochastic variable cost of risk, general assumptions, regional emissions, conservation load value (\$/MW) and new CapEx.
19_PriSM_7.0_GUROBI_1207 20_IRP_SCC_PS	PRiSM Model Files- Portfolio Studies	Excel	PRiSM model - must have Gurobi license to run. Social cost of carbon applied to net purchases, includes net purchase included storage purchases. Includes a summary of resource selected, financial summary, clean goal progress, loads & resources, demand response, resource data, energy efficiency selected, Aurora resource results, transmission annual revenue requirement from amortization model, annual cost of resource options, resources (MWh), hydro & contracts market value, stochastic variable cost of risk, general assumptions, regional emissions, conservation load value (\$/MW) and new CapEx.
20_PriSM_7.0_GUROBI_1207 20_IRP_EE-Avg Mrkt Emissions	PRiSM Model Files- Portfolio Studies	Excel	PRiSM model - must have Gurobi license to run. Use average market emission rate rather than incremental for EE SCC calculation, all other PRS inputs/constraints are the same, this study is conducted iteratively, meaning resulting EE is added back in the model to adjust loads and re-run. Includes a summary of resource selected, financial summary, clean goal progress, loads & resources,

			demand response, resource data, energy efficiency selected, Aurora resource results, transmission annual revenue requirement from amortization model, annual cost of resource options, resources (MWh), hydro & contracts market value, stochastic variable cost of risk, general assumptions, regional emissions, conservation load value (\$/MW) and new CapEx.
21_PRISM_7.0_GUROBI_120720_IRP_PRS_Draft_Maximum Benefit	PRiSM Model Files- Portfolio Studies	Excel	PRiSM model - must have Gurobi license to run. Washington maximum benefit. Includes a summary of resource selected, financial summary, clean goal progress, loads & resources, demand response, resource data, energy efficiency selected, Aurora resource results, transmission annual revenue requirement from amortization model, annual cost of resource options, resources (MWh), hydro & contracts market value, stochastic variable cost of risk, general assumptions, regional emissions, conservation load value (\$/MW) and new CapEx.
PRiSM Draft Results_120720	PRiSM Model Files- Portfolio Studies	Excel	Scenario list, summary data, sensitivity summary, sensitivity data, summary resources PRS, existing resources, annual summary by scenario, summary table of PVRR (\$ Mill) by state and select years, cost vs risk by scenario, clean goal, GHG emissions, avoided costs for SR/EE.
PRiSM Model Guide	PRiSM Model Files- Portfolio Studies	Word	User guide for the PRiSM models.
2021 IRP New Supply Side Resource Options	Appendix I	Excel	Supply side resource option assumptions for cost, size, availability.

# 2021 Electric Integrated Resource Plan

## Appendix J – Confidential Inputs and Models

Idaho – Confidential pursuant to Sections 74-109, Idaho Code

Washington – Confidential per WAC 480-07-160



## Appendix J Content

The Company makes data input files in native format, models, and other various content used for its Integrated Resource Planning process available to stakeholders. Non-confidential, non-proprietary IRP content can also be found at [Integrated Resource Planning \(myavista.com\)](https://myavista.com). In a manner to further increase transparency and provide clarity for stakeholders, the following table provides context on data files, models and other content included in Appendix J.

File Name	Folder	File Type	Description of Content
ARAM Model Guide	ARAM-Reliability Studies	Word	User guide for ARAM models.
ARAM_2021_IRP_2025_No_Additions_121020_With Colstrip	ARAM-Reliability Studies	Excel	Reliability study considering no additions, with Colstrip for select year.
ARAM_2021_IRP_2025_No_Additions_121020_Without Colstrip	ARAM-Reliability Studies	Excel	Reliability study considering no additions, without Colstrip for select year.
ARAM_2021_IRP_2025_PRS	ARAM-Reliability Studies	Excel	Reliability study considering PRS for select year.
ARAM_2021_IRP_2030_330 Market PRS	ARAM-Reliability Studies	Excel	Reliability study considering 330 market and PRS for select year.
ARAM_2021_IRP_2030_330 Market Scenario 5	ARAM-Reliability Studies	Excel	Reliability study considering 330 market scenario 5 for select year.
ARAM_2021_IRP_2030_330 Market Scenario 10	ARAM-Reliability Studies	Excel	Reliability study considering 330 market scenario 10 for select year.
ARAM_2021_IRP_2030_330 Market Scenario 16	ARAM-Reliability Studies	Excel	Reliability study considering 330 market scenario 16 for select year.
ARAM_2021_IRP_2030_333MW-CTs-330MW Market	ARAM-Reliability Studies	Excel	Reliability study considering 333 MW of CTs and 330 market scenario for select year.
ARAM_2021_IRP_2040_No_Additions_121020	ARAM-Reliability Studies	Excel	Reliability study considering no additions, for select year
ARAM_2021_IRP_2040_PRS	ARAM-Reliability Studies	Excel	Reliability study considering PRS for select year.
ARAM_2021_IRP_2040_PRS_3 unit	ARAM-Reliability Studies	Excel	Reliability study considering PRS and 3 units for select year.

ARAM_2021_IRP_2040_Scenari o6-CR2045	ARAM-Reliability Studies	Excel	Reliability study considering scenario 6-CR2045 for select year.
2021 IRP Change Sets	Aurora Files	Aurora	Changes set used for 2021 IRP.
2021 IRP Deterministic	Aurora Files	Aurora	Deterministic model used for 2021 IRP.
2021 IRP Deterministic_ClimateChange	Aurora Files	Aurora	Deterministic model updated for climate change used for 2021 IRP.
2021 IRP Deterministic_High_NG_Prices	Aurora Files	Aurora	Deterministic model updated for high natural gas prices used for 2021 IRP.
2021 IRP Deterministic_Low_NG_Prices	Aurora Files	Aurora	Deterministic model updated for low natural gas prices used for 2021 IRP.
2021 IRP Deterministic_No_AVA_EE	Aurora Files	Aurora	Deterministic model updated for no Avista energy efficiency used for 2021 IRP.
2021 IRP Deterministic_SCC	Aurora Files	Aurora	Deterministic model updated for social cost of carbon used for 2021 IRP.
2021 IRP QuickViews	Aurora Files	Aurora	Saved quickviews used for 2021 IRP.
2021 IRP Stochastic	Aurora Files	Aurora	Stochastic model used for 2021 IRP.
2021 IRP_Risk_Tables	Aurora Files	Aurora	Risk tables used for 2021 IRP.
Aurora Model Guide	Aurora Files	Word	User guide for the Aurora models
IRP_2021_US_Canada_DB_201 9_v1	Aurora Files	Database	Aurora database for US/Canada
New Resources_Expected Case	Aurora Files	Excel	Annual table inputs, summary, resource tables inputs and RMT inputs used for the 2021 IRP.
DR Input Generator – Avista 03_01_21	Appendix J	Excel	Demand response participation rates, impact, details by program used in the 2021 IRP.





# 2021 Electric Integrated Resource Plan

## Appendix K – Load Forecast Supplement



## Appendix K

### Climate Change

The process of integrating climate change into the load forecast starts with estimating the long-run trend in the 20-year average of annual heating degree days (HDD) and cooling degree days (CDD). Ideally, trending the 20-year moving average introduces climate change while still maintain a smoothed measure of normal (average) weather. Figure K.1 demonstrates the issues that need to be considered when choosing a method to introduce climate change using HDD.

**Figure K.1: Issues Related to Forecasted HDD and CDD**

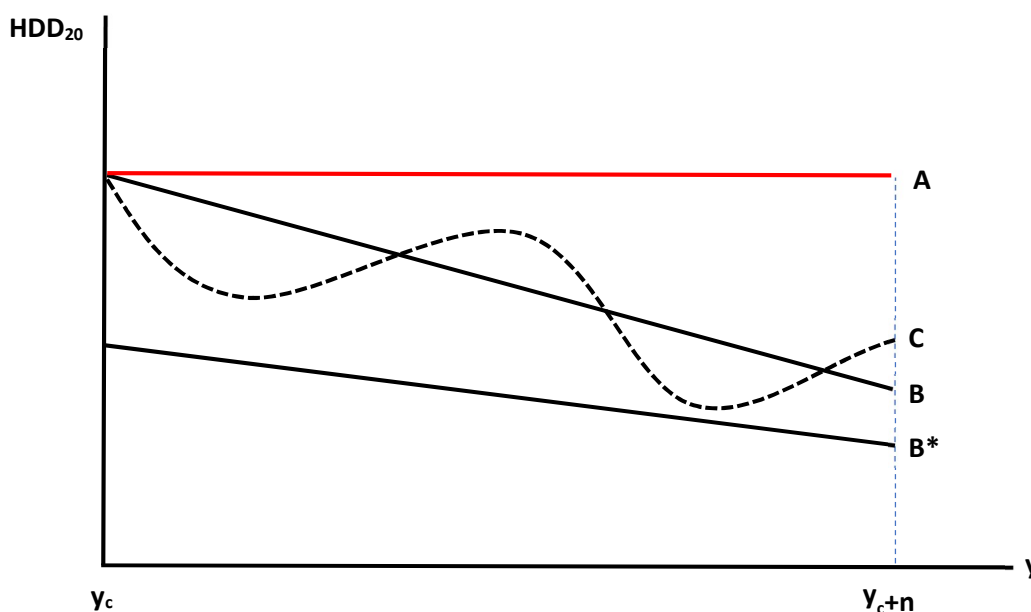

Line A reflects the most recent 20-year moving average ( $HDD_{20}$ ) ending with the current calendar year ( $y_c$ ). In the current IRP, this is the 2000-2019 period. Without a climate change adjustment, Line A is the assumed normal weather over  $Y_{c+n}$ . Line A will only shift up or down as the 20-year average is updated with a new year of HDD data. If climate change is occurring, then line A will gradually shift down over time along the vertical axis.

A forward-looking climate change adjustment to line A requires introducing a trended moving going forward in time—this is shown by line B or C. However, a method that produces line C is problematic because, compared to line B, it introduces a significant amount of year-to-year variation over the forecast period. In turn, this produces significant amount of volatility in forecasted load, revenues, and earnings that may not be acceptable to the planning process. However, even if a method produces a smooth trend over the forecast horizon, another problem can arise. Specifically, if the method that produces line B generates large shifts in the slope and intercept between forecast runs (i.e., the forecast completed in year  $y$  versus the forecast completed in year  $y+1$ ), this method will also

produce a level of volatility that may not be acceptable. This is shown by line B\* compared to line B. This analysis shows that the method chosen should be stable over and between forecast runs, yet still capture the current best guess path of climate change over the forecast horizon.

The method used by Avista, starts with an analysis of the 20-year moving average of HDD and CDD using a 20-year moving average time-series going back to 1967. In other words, the first observation in the time series is the 20-year moving average for the period 1948-1967, where 1948 is the start of Avista's (AVA) annual billing adjusted HDD data (discussed above). After analyzing the time-series behavior of both series, the following time series regression equations are estimated:

$$[1A] \quad \Delta HDD_{20,y}^{AVA} = \delta_{HDD} + \theta_1 \Delta HDD_{20,y-1}^{AVA} + \theta_2 \Delta HDD_{20,y-2}^{AVA} + \theta_3 \Delta HDD_{20,y-3}^{AVA} + \theta_4 \Delta HDD_{20,y-4}^{AVA} + \theta_5 \Delta HDD_{20,y-5}^{AVA} + \epsilon_y$$

$$[2A] \quad \Delta CDD_{20,y}^{AVA} = \delta_{CDD} + \gamma_1 \Delta CDD_{20,y-1}^{AVA} + \gamma_2 \Delta CDD_{20,y-2}^{AVA} + \gamma_3 \Delta CDD_{20,y-3}^{AVA} + \gamma_4 \Delta CDD_{20,y-4}^{AVA} + \gamma_5 \Delta CDD_{20,y-5}^{AVA} + \epsilon_y$$

Here,  $\epsilon_y$  is a white noise, mean zero error term.

Assuming model stationarity, the constant value  $\delta$  can be used to calculate the long-run expected change in annual HDD and CDD:

$$[3A] \quad \mu_{\Delta HDD} = \frac{\hat{\delta}_{HDD}}{1 - (\hat{\theta}_1 + \hat{\theta}_2 + \hat{\theta}_3 + \hat{\theta}_4 + \hat{\theta}_5)}$$

$$[4A] \quad \mu_{\Delta CDD} = \frac{\hat{\delta}_{CDD}}{1 - (\hat{\gamma}_1 + \hat{\gamma}_2 + \hat{\gamma}_3 + \hat{\gamma}_4 + \hat{\gamma}_5)}$$

This can then be applied to the current 20-year moving average to generate trended values out a total of N years:

$$[5A] \quad F(HDD_{20,y_c+n}^{AVA}) = HDD_{20,y_c}^{AVA} + n\mu_{\Delta HDD} \text{ for } n = 1, \dots, N$$

$$[6A] \quad F(CDD_{20,y_c+n}^{AVA}) = CDD_{20,y_c}^{AVA} + n\mu_{\Delta CDD} \text{ for } n = 1, \dots, N$$

For most IRPs, N = 25. If monthly values are needed over the forecast period, then the annual values can be allocated monthly as follows:

$$[7A] \quad F(HDD_{20,t,y_c+n}^{AVA}) = \bar{h}_t F(HDD_{20,y_c+n}^{AVA}) \text{ where } \bar{h}_t = \frac{\sum_{j=0}^{19} h_{t,y_c-j}}{20} \text{ for } t = \text{Jan}, \dots, \text{Dec}$$

$$[8A] \quad F(CDD_{20,t,y_c+n}^{AVA}) = \bar{c}_t F(CDD_{20,y_c+n}^{AVA}) \text{ where } \bar{c}_t = \frac{\sum_{j=0}^{19} c_{t,y_c-j}}{20} \text{ for } t = \text{Jan}, \dots, \text{Dec}$$

Here,  $\bar{h}_t$  and  $\bar{c}_t$  are the 20-year average share of HDD and CDD, respectively, in month  $t$ . These monthly values can be used to convert the annual IRP simulation model forecasts to monthly values or, alternatively, adding climate change to the peak load forecast. It should be noted that an analysis of the share of HDD and CDD by month going back to 1948 do not show any apparent trends. This suggests, even under climate change, the relative allocation of HDD and CDD across the months each year will not change significantly going forward.

Returning to the annual, trended moving average forecasts of HDD and CDD, those can be used to estimate the long-run impact on annual residential UPC ( $UPC_{r,y}$ ) in the face of climate change, which can be applied to the long-run annual residential UPC forecast in the IRP simulation model. This process starts with the following regression model:

$$[9A] \quad UPC_{r,y} = \alpha_0 + \alpha_1 HDD_y^{AVA} + \alpha_2 CDD_y^{AVA} + \alpha_3 T^* + \alpha_4 D_{1997-1999=} + \alpha_5 D_{2017-2009=1} + \epsilon_y$$

Here  $HDD_y^{AVA}$  and  $CDD_y^{AVA}$  are the actual Avista adjusted degree days in year  $y$ ;  $T^*$  is a linear trend starting with  $T^*= 1$  in 1997 (the beginning of the historical series); the structural change dummies control for a change in data reporting after 1999 and the LEAP gas program that ended in 2019; and  $\epsilon_y$  is  $N(0, \sigma)$ . None linear trends were also tried, by the linear trend produced the best fit on the annual data. Using the estimated coefficients (a), a forecast for UPC under climate change can be generated as follows:

$$[10A] \quad F(UPC_{r,y_c+n}) = a_0 + a_1(HDD_{20,y_c}^{AVA} + n\mu_{\Delta HDD}) + a_2(CDD_{20,y_c}^{AVA} + n\mu_{\Delta CDD}) + a_3(T_{y_c}^* + n) \text{ for } n = 0, \dots, N$$

Simplifying terms:

$$[11A] \quad F(UPC_{r,y_c+n}) = a_0 + a_1 HDD_{20,y_c}^{AVA} + a_2 CDD_{20,y_c}^{AVA} + a_3(T_{y_c}^* + n) + (a_1\mu_{\Delta HDD} + a_2\mu_{\Delta CDD})n$$

$$[12A] \quad F(UPC_{r,y_c+n}) = (a_0 + a_1 HDD_{20,y_c}^{AVA} + a_2 CDD_{20,y_c}^{AVA}) + a_3(T_{y_c}^* + n) + bn \text{ where } b \equiv (a_1\mu_{\Delta HDD} + a_2\mu_{\Delta CDD})$$

Note that  $b \equiv (a_1\mu_{\Delta HDD} + a_2\mu_{\Delta CDD})$  is treated as the annual marginal impact of total climate change on UPC. Using the times series questions [3A] and [4A], we have  $\mu_{\Delta HDD} = -9.6$  and  $\mu_{\Delta CDD} = 3.4$ . Combining these with the estimated values of  $a_1 = 0.732$  and  $a_2 = 1.170$  we have:

$$[13A] \quad b = a_1\mu_{\Delta HDD} + a_2\mu_{\Delta CDD} = 0.732 \cdot (-9.6) + 1.170 \cdot (3.4) = -3.049$$

This means the net impact of falling HDD and rising CDD is to reduce residential UPC approximately 3 kWh a year, or a total cumulative impact  $b \cdot N$ . Note that in the case of the NPCC data, [x.x] becomes:

$$[14A] \quad b = 0.732 \cdot (-38) + 1.170 \cdot (8) = -18.455$$

In the context of the IRP simulation model, it is necessary to convert the annual load and energy forecasts into a monthly number. Without climate change, this is straightforward because it only requires extrapolating out the most recent 5-year forecast using the forecasted long-run annual growth rates from the simulation model. This approach essentially assumes the share of load by month in each year will not change significantly over time, which is equivalent to assuming the most current 20-year moving average of HDD and CDD is constant over the forecast horizon (see again Line A in Figure 1A).

However, with climate change, the share of load occurring each month will change overtime. This means a method for estimating those future monthly load shares is necessary to allocate the annual load values from the IRP simulation model. Since total load can be trended over time, the method chosen here estimates a regression using the first difference of month-to-month changes in total load and HDD and CDD, monthly dummies ( $D_{t,y}$ ), and an ARIMA error correction term to account for short-term autocorrelation:

$$[15A] \Delta L_{t,y} = \beta_0 + \beta_1 \Delta HDD_{t,y}^{AVA} + \beta_2 \Delta CDD_{t,y}^{AVA} + \beta_{3,SD} D_{t,y} + ARIMA\epsilon_{t,y}(p, d, q)(p_{12}, d_{12}, q_{12})_{12}$$

Here  $\Delta L_{t,y} = L_t - L_{t-1}$ ;  $\Delta HDD_{t,y}^{AVA} = HDD_t^{AVA} - HDD_{t-1}^{AVA}$ ;  $\Delta CDD_{t,y}^{AVA} = CDD_t^{AVA} - CDD_{t-1}^{AVA}$ . Note that as will be shown shortly,  $\beta_0$  reflects the growth in load that occurs each month over the forecast horizon. If  $\beta_0 > 0$ , then this reflects positive load growth;  $\beta_0 = 0$  means no load growth; and  $\beta_0 < 0$ .

For the purposes of forecasting future load shares, the ARIMA portion is ignored and the forecasted change in load relies solely on the estimated coefficients (b). This is done because simulations including and excluding error term corrections found little impact after the first year:

$$[16A] F(\Delta L_{t,y_c+n}) = b_0 + b_1 F(\Delta HDD_{20,t,y_c+n}^{AVA}) + b_2 F(\Delta CDD_{20,t,y_c+n}^{AVA}) + b_{3,SD} D_{t,y_c+n} \text{ for } n = 1, \dots, N$$

Given [16A] and forecast of HDD and CDD, a monthly load forecast can start with,  $L_{12,y_c}$ , the last actual value for December of the most recent full calendar year, and the forecast would carry to year N. For simplicity, note that the forecast notation,  $F(\cdot)$ , has been dropped:

$$\begin{aligned} L_{1,y_c+1} &= L_{12,y_c} + \Delta L_{1,y_c+1} \\ L_{2,y_c+1} &= L_{1,y_c+1} + \Delta L_{2,y_c+1} \\ L_{3,y_c+1} &= L_{2,y_c+1} + \Delta L_{3,y_c+1} \\ &\vdots \end{aligned}$$

$$\begin{aligned}
L_{11,y_c+1} &= L_{10,y_c+1} + \Delta L_{11,y_c+1} \\
L_{12,y_c+1} &= L_{11,y_c+1} + \Delta L_{12,y_c+1} \\
L_{1,y_c+2} &= L_{12,y_c+1} + \Delta L_{1,y_c+2} \\
&\vdots \\
L_{11,y_c+2} &= L_{10,y_c+2} + \Delta L_{11,y_c+2} \\
L_{12,y_c+2} &= L_{11,y_c+2} + \Delta L_{12,y_c+2} \\
&\vdots \\
L_{11,y_c+N} &= L_{10,y_c+N} + \Delta L_{11,y_c+N} \\
L_{12,y_c+N} &= L_{11,y_c+N} + \Delta L_{12,y_c+N}
\end{aligned}$$

This process generates a series of total load values for each calendar year,  $n$ , over the forecast horizon.

$$[17A] \quad L_{y_c+n} = \sum_{t=1}^{12} L_{t,y_c+n}$$

Therefore, for each year,  $n$ , the forecasted load share over that year can be calculated as:

$$[18A] \quad \sum_{t=1}^{12} \left( \frac{L_{t,y_c+n}}{L_{y_c+n}} \right) = \sum_{t=1}^{12} \lambda_{t,y_c+1} = 1$$

The monthly load shares can be applied to the annual forecast values in the simulation model convert the annual forecasts to monthly values. However, prior to this allocation, it may be required to manually adjust the estimated constant,  $b_0$ , so that the average annual load growth rate associated with [16A] matches the average annual growth rate from the IRP simulation model. That is, because [16A] is being estimated from historical data,  $b_0$  reflects historical non-weather related growth. This can be seen by re-arranging [17A] as follows:

$$[19A] \quad L_{y_c+n} = \sum_{t=1}^{12} L_{t,y_c+n} = L_{12,y_c-(n-1)} + \sum_{t=1}^{11} L_{t,y_c+n} + \sum_{t=1}^{12} \Delta L_{t,y_c+n} \text{ for } n = 1, \dots, N$$

Substituting in the estimated regression [16A]:

$$[20A] \quad L_{y_c+n} = L_{12,y_c-(n-1)} + \sum_{t=1}^{11} L_{t,y_c+n} + \sum_{t=1}^{12} (b_0 + b_1 \Delta HDD_{20,t,y_c+n}^{AVA} + b_2 \Delta CDD_{20,t,y_c+n}^{AVA} + b_3 SD_{t,y})$$

$$[21A] L_{y_c+n} = 12b_0 + L_{12,y_c-(n-1)} + \sum_{t=1}^{11} L_{t,y_c+n} + \sum_{t=1}^{12} (b_1 \Delta HDD_{20,t,y_c+n}^{AVA} + b_2 \Delta CDD_{20,t,y_c+n}^{AVA} + b_3 SD_{t,y})$$

[21A] shows that for any calendar year, non-weather-related load accumulates by 12b<sub>0</sub>. Accounting for the accumulation over all N periods:

$$[22A] L_{12,y_c+N} = L_{12,y_c} + \sum_{t=1}^{12} \Delta L_{t,y_c+1} + \sum_{t=1}^{12} \Delta L_{t,y_c+2} + \sum_{t=1}^{12} \Delta L_{t,y_c+3} \dots + \sum_{t=1}^{12} \Delta L_{t,y_c+(N-1)} + \sum_{t=1}^{12} \Delta L_{t,y_c+N}$$

$$[23A] L_{12,y_c+N} = L_{12,y_c} + \sum_{n=1}^N (\sum_{t=1}^{12} \Delta L_t)_{y_c+n}$$

$$[24A] L_{12,y_c+N} = L_{12,y_c} + \sum_{n=1}^N \left( \sum_{t=1}^{12} (b_0 + b_1 \Delta HDD_{20,t}^{AVA} + b_2 \Delta CDD_{20,t}^{AVA} + b_3 SD_{t,y}) \right)_{y_c+n}$$

$$[25A] L_{12,y_c+N} = L_{12,y_c} + N12b_0 + \sum_{n=1}^N \left( \sum_{t=1}^{12} (b_1 \Delta HDD_{20,t}^{AV} + b_2 \Delta CDD_{20,t}^{AVA} + b_3 SD_{t,y}) \right)_{y_c+n}$$

Non-weather related load accumulation over all N periods is N12b<sub>0</sub>.

To integrate climate change into the peak load model, note that any 20-year moving average can be used to calculate the implied average temperature associated with a given month, t; note that C is the cut-off for CDD and HDD, which Avista sets at 65 degrees, and D is the number of days in month t:

$$[26A] CDD_{20,t,y}^{AVA} = \frac{\sum_{j=0}^{20} CDD_{t,y-j}}{20} = \frac{\sum_{j=0}^{19} D (\bar{T}_{d,t,y-j} - C)}{20} = \frac{\sum_{j=0}^{19} (D \bar{T}_{d,t,y-j} - D \cdot C)}{20} = \frac{-20 \cdot D \cdot C + N \sum_{j=0}^{19} \bar{T}_{d,t,y}}{20} = -D \cdot C + D \frac{\sum_{j=0}^{19} \bar{T}_{d,t,y-j}}{20} = -D \cdot C + D \bar{T}_{20,t,y} \Rightarrow \bar{T}_{20,t,y} = \frac{D \cdot C + CDD_{20,t,y}^{AVA}}{D}$$

$$[27A] HDD_{20,t,y}^{AVA} = \frac{\sum_{j=0}^{19} HDD_{t,y-j}}{20} = \frac{\sum_{j=0}^{19} D (C - \bar{T}_{d,t,y-j})}{20} = \frac{\sum_{j=0}^{19} (D \cdot C - D \bar{T}_{d,t,y-j})}{20} = \frac{20 \cdot D \cdot C - D \sum_{j=0}^{19} \bar{T}_{d,t,y-j}}{20} = D \cdot C - D \frac{\sum_{j=0}^{19} \bar{T}_{d,t,y-j}}{20} = D \cdot C - D \cdot \bar{T}_{20,t,y} \Rightarrow \bar{T}_{20,t,y} = \frac{D \cdot C - HDD_{20,t,y}^{AVA}}{D}$$

Given forecasted values for the 20-year moving average of HDD and CDD (equations [5A] and [6A]), the formulas above are used to calculate the implied 20-year moving



average of average temperature forecasted for month t. The average annual change in this temperature can be applied to calculate the expected change in average summer and winter peak temperatures for integrating climate change into the peak load forecast. Note that the growing (summer) or falling (winter) temperatures will act to accelerate growth (in the case of summer) or decelerate growth (in the case of winter), in addition to any impact associated with assumed economic growth. Thus:

$$[28A] \Delta \bar{T}_{20,t} = \frac{\bar{T}_{20,t,2045} - \bar{T}_{20,t,y_c}}{(2045 - y_c)} \text{ for either CDD or HDD for month } t$$

$$[29A] F(A_{t,y_c+n,MAX}) = \frac{\sum_{j=0}^{19} A_{t,y_c-j,MAX}}{20} + n \cdot \Delta \bar{T}_{CDD20,t} \text{ for } n = 1, \dots, N \text{ years}$$

$$[30A] F(A_{t,y_c+n,MIN}) = \frac{\sum_{j=0}^{19} A_{t,y_c-j,MIN}}{20} + n \cdot \Delta \bar{T}_{HDD20,t} \text{ for } n = 1, \dots, N \text{ years}$$

From each series  $A_{t,y}$ , MAX is based on maximum daily average temperature and MIN is based on minimum average daily temperatures. The first expression on the right of the equals sign is the current 20-year historic average of MAX and MIN temperatures. The second expression is the trending factor applied to the 20-year average. These trended averages can then be converted back into CDD and HDD to be used in the peak-load forecast model. These provide a trended values of CDD and HDD associated with peak load.