

**1547™**

**IEEE Standard for Interconnecting  
Distributed Resources with Electric  
Power Systems**

**Standards Coordinating Committee 21**

Sponsored by the  
Standards Coordinating Committee 21 on  
Fuel Cells, Photovoltaics, Dispersed Generation, and Energy Storage



Published by  
The Institute of Electrical and Electronics Engineers, Inc.  
3 Park Avenue, New York, NY 10016-5997, USA

28 July 2003

Print: SH95144  
PDF: SS95144

# IEEE Standard for Interconnecting Distributed Resources with Electric Power Systems

Sponsor

**Standards Coordinating Committee 21  
(Fuel Cells, Photovoltaics, Dispersed Generation, and Energy Storage)**

Approved 12 June 2003

**IEEE-SA Standards Board**

**Abstract:** This standard is the first in the 1547 series of interconnection standards and is a benchmark milestone demonstrating the open consensus process for standards development. Traditionally, utility electric power systems (EPS--grid or utility grid) were not designed to accommodate active generation and storage at the distribution level. As a result, there are major issues and obstacles to an orderly transition to using and integrating distributed power resources with the grid. The lack of uniform national interconnection standards and tests for interconnection operation and certification, as well as the lack of uniform national building, electrical, and safety codes, are understood. IEEE Std 1547 and its development demonstrate a model for ongoing success in establishing additional interconnection agreements, rules, and standards, on a national, regional, and state level. IEEE Std 1547 has the potential to be used in federal legislation and rule making and state public utilities commission (PUC) deliberations, and by over 3000 utilities in formulating technical requirements for interconnection agreements for distributed generators powering the electric grid.

This standard focuses on the technical specifications for, and testing of, the interconnection itself. It provides requirements relevant to the performance, operation, testing, safety considerations, and maintenance of the interconnection. It includes general requirements, response to abnormal conditions, power quality, islanding, and test specifications and requirements for design, production, installation evaluation, commissioning, and periodic tests. The stated requirements are universally needed for interconnection of distributed resources (DR), including synchronous machines, induction machines, or power inverters/converters and will be sufficient for most installations. The criteria and requirements are applicable to all DR technologies, with aggregate capacity of 10 MVA or less at the point of common coupling, interconnected to electric power systems at typical primary and/or secondary distribution voltages. Installation of DR on radial primary and secondary distribution systems is the main emphasis of this document, although installation of DR on primary and secondary network distribution systems is considered. This standard is written considering that the DR is a 60 Hz source.

**Keywords:** certification; codes; commissioning, dc injection; design, field, installation, production tests; communications; diesel generators; distributed generation, power; resources; electric distribution systems; dispersed generation, storage; energy storage; faults; flicker; fuel cells; generators; grid; harmonics; IEEE; induction machines; inverters; interconnection requirements and specifications; islanding; microturbines; monitoring and control; paralleling; power converters, networks, quality; photovoltaic power systems; point of common coupling; public utility commissions; reclosing coordination; regulations; rule making, federal, national, regional, state; standards; synchronous machines; testing; utilities; wind energy systems

---

The Institute of Electrical and Electronics Engineers, Inc.  
3 Park Avenue, New York, NY 10016-5997, USA

Copyright © 2003 by the Institute of Electrical and Electronics Engineers, Inc.  
All rights reserved. Published 28 July 2003. Printed in the United States of America.

IEEE is a registered trademark in the U.S. Patent & Trademark Office, owned by the Institute of Electrical and Electronics Engineers, Incorporated.

Print: ISBN 0-7381-3720-0 SH95144  
PDF: ISBN 0-7381-3721-9 SS95144

*No part of this publication may be reproduced in any form, in an electronic retrieval system or otherwise, without the prior written permission of the publisher.*

**IEEE Standards** documents are developed within the IEEE Societies and the Standards Coordinating Committees of the IEEE Standards Association (IEEE-SA) Standards Board. The IEEE develops its standards through a consensus development process, approved by the American National Standards Institute, which brings together volunteers representing varied viewpoints and interests to achieve the final product. Volunteers are not necessarily members of the Institute and serve without compensation. While the IEEE administers the process and establishes rules to promote fairness in the consensus development process, the IEEE does not independently evaluate, test, or verify the accuracy of any of the information contained in its standards.

Use of an IEEE Standard is wholly voluntary. The IEEE disclaims liability for any personal injury, property or other damage, of any nature whatsoever, whether special, indirect, consequential, or compensatory, directly or indirectly resulting from the publication, use of, or reliance upon this, or any other IEEE Standard document.

The IEEE does not warrant or represent the accuracy or content of the material contained herein, and expressly disclaims any express or implied warranty, including any implied warranty of merchantability or fitness for a specific purpose, or that the use of the material contained herein is free from patent infringement. IEEE Standards documents are supplied “**AS IS.**”

The existence of an IEEE Standard does not imply that there are no other ways to produce, test, measure, purchase, market, or provide other goods and services related to the scope of the IEEE Standard. Furthermore, the viewpoint expressed at the time a standard is approved and issued is subject to change brought about through developments in the state of the art and comments received from users of the standard. Every IEEE Standard is subjected to review at least every five years for revision or reaffirmation. When a document is more than five years old and has not been reaffirmed, it is reasonable to conclude that its contents, although still of some value, do not wholly reflect the present state of the art. Users are cautioned to check to determine that they have the latest edition of any IEEE Standard.

In publishing and making this document available, the IEEE is not suggesting or rendering professional or other services for, or on behalf of, any person or entity. Nor is the IEEE undertaking to perform any duty owed by any other person or entity to another. Any person utilizing this, and any other IEEE Standards document, should rely upon the advice of a competent professional in determining the exercise of reasonable care in any given circumstances.

Interpretations: Occasionally questions may arise regarding the meaning of portions of standards as they relate to specific applications. When the need for interpretations is brought to the attention of IEEE, the Institute will initiate action to prepare appropriate responses. Since IEEE Standards represent a consensus of concerned interests, it is important to ensure that any interpretation has also received the concurrence of a balance of interests. For this reason, IEEE and the members of its societies and Standards Coordinating Committees are not able to provide an instant response to interpretation requests except in those cases where the matter has previously received formal consideration.

Comments for revision of IEEE Standards are welcome from any interested party, regardless of membership affiliation with IEEE. Suggestions for changes in documents should be in the form of a proposed change of text, together with appropriate supporting comments. Comments on standards and requests for interpretations should be addressed to:

Secretary, IEEE-SA Standards Board  
445 Hoes Lane  
P.O. Box 1331  
Piscataway, NJ 08855-1331  
USA

Note: Attention is called to the possibility that implementation of this standard may require use of subject matter covered by patent rights. By publication of this standard, no position is taken with respect to the existence or validity of any patent rights in connection therewith. The IEEE shall not be responsible for identifying patents for which a license may be required by an IEEE standard or for conducting inquiries into the legal validity or scope of those patents that are brought to its attention.

Authorization to photocopy portions of any individual standard for internal or personal use is granted by the Institute of Electrical and Electronics Engineers, Inc., provided that the appropriate fee is paid to Copyright Clearance Center. To arrange for payment of licensing fee, please contact Copyright Clearance Center, Customer Service, 222 Rosewood Drive, Danvers, MA 01923 USA; +1 978 750 8400. Permission to photocopy portions of any individual standard for educational classroom use can also be obtained through the Copyright Clearance Center.

# Introduction

(This introduction is not part of IEEE Std 1547-2003, IEEE Standard for Interconnecting Distributed Resources with Electric Power Systems.)

IEEE Std 1547-2003 is the first of a series of standards being developed by Standards Coordinating Committee 21 on Fuel Cells, Photovoltaics, Dispersed Generation, and Energy Storage (SCC21) concerning distributed resources interconnection. The titles of the additional documents in that series follow.

- IEEE P1547.1™ Draft Standard For Conformance Test Procedures for Equipment Interconnecting Distributed Resources with Electric Power Systems
- IEEE P1547.2™ Draft Application Guide for IEEE Std 1547-2003, IEEE Standard for Interconnecting Distributed Resources with Electric Power Systems
- IEEE P1547.3™ Draft Guide for Monitoring, Information Exchange, and Control of Distributed Resources Interconnected with Electric Power Systems

This first publication of IEEE Std 1547-2003 is an outgrowth of the changes in the environment for production and delivery of electricity and builds on prior IEEE recommended practices and guidelines developed by SCC21 [e.g., IEEE Std 929™-2000, IEEE Recommended Practice for Utility Interface of Photovoltaic (PV) Systems], and Standards Coordinating Committee 23 on Dispersed Storage and Generation (e.g., IEEE Std 1001™-1988, Guide for Interfacing Dispersed Storage and Generation Facilities with Electric Utility Systems).

Traditionally, utility electric power systems (EPS) were not designed to accommodate active generation and storage at the distribution level. The technologies and operational concepts to properly integrate distributed resources (DR) into the existing EPS continue to be further developed to fully realize benefits and to avoid negative impacts on system reliability and safety.

There is a critical need to have a single document of consensus standard technical requirements for DR interconnection rather than having to conform to numerous local practices and guidelines. This standard addresses that critical need by providing uniform criteria and requirements relevant to the performance, operation, testing, safety considerations, and maintenance of the interconnection.

The intent of this standard is to define the technical requirements in a manner that can be universally adopted. The universality relates not only to the technical aspects, but also to the adoption of this standard as being pertinent across a number of industries and institutions, e.g., hardware manufacturers, utilities, energy service companies, codes and standards organizations, regulators and legislators, and other interested entities.

This standard focuses on the technical specifications for, and testing of, the interconnection itself, and not on the types of the DR technologies. This standard aims to be technology neutral, although cognizant that the technical attributes of DR and the types of EPSs do have a bearing on the interconnection requirements. The addition of DR to an EPS will change the system and its response in some manner. Although this standard establishes criteria and requirements for interconnection, this standard is not a design handbook nor is it an application guideline. This standard provides the minimum functional technical requirements that are universally needed to help assure a technically sound interconnection. Any additional local requirements should not be implemented to the detriment of the functional technical requirements of this standard.

It is beyond the scope of this standard to address the methods used for performing EPS impact studies, mitigating limitations of the Area EPS, or for addressing the business or tariff issues associated with interconnection.

## Participants

At the time this standard was completed, the Standards Coordinating Committee 21 on Fuel Cells, Photovoltaics, Dispersed Generation, and Energy Storage had the following membership:

**Richard DeBlasio, Chair**  
**Steve Chalmers, Vice Chair**  
**Thomas S. Basso, Secretary**

Jerry Anderson  
Jay Chamberlin  
James M. Daley  
Douglas C. Dawson  
N. Richard Friedman

William E. Feero  
Frank Goodman  
Kelvin Hecht  
Barry Hornberger  
Joseph L. Koepfinger  
Benjamin Kroposki

Robert McConnell  
John Stevens  
John Wiles  
John Wohlgemuth  
Timothy P. Zgonena

At the time this standard was completed, the Distributed Resources and Electric Power Systems Interconnection Working Group (P1547 WG) of the Standard Coordinating Committee 21 (SCC21) on Fuel Cells, Photovoltaics, Dispersed Generation, and Energy Storage had the following membership who participated in the preparation of this standard:

**Richard DeBlasio, Chair**  
**Frank Goodman, Vice Chair**      **Joseph L. Koepfinger, Vice Chair**  
**Thomas S. Basso, Secretary**

William J. Ackerman  
Larry Adams  
J. Reese Adomaitis  
Pirous (Pete) Ahkami  
Naeem Ahmad  
Richard (Rick) Allison  
Peter Amos  
Roger A. Argeñal  
Martin Baier  
Philip A. Baker  
John C. Balachandra  
Philip Barker  
David Barone  
David Bassett  
Alan Bax  
Edward Beardsworth  
Terry Becker  
Robert W. Beckwith  
Michael Behnke  
Stephen Berger  
Michael L. S. Bergey  
Charles Berry  
Vijay Bhavaraju  
John Bilash  
Stanley Blazewicz  
Werner M. Blumer  
Robert E. Boettner  
Bogdan Borowy  
Ward Bower  
Gerry Boyd  
Carl C. Brittain  
Steven R. Brockschink  
M. N. (Mac) Brodie

Bill Brooks  
Jack Brouwer  
Demy Bucaneg  
Brian Bui  
Mike Bui  
David Burnett  
Michael V. Byrnes  
John J. Bzura  
Raphael Caire  
Fernando Calderon  
Bob Cantwell  
Scott Anthony Castelaz  
Alfonso Centuori  
Steve Chalmers  
Jay Chamberlin  
Rob A. Chandler  
Liuchen Chang  
Jamie Chapman  
Joe Chau  
Simon H. Cheng  
Muhammad Choudhry  
Kurt K. Christensen  
Lloyd Cibulka  
Geoffrey F. Clark  
David A. Cohen  
Alan Collinson  
Reginald Comfort  
David Conover  
Larry E. Conrad  
Stephen P. Conrad  
William (Bill) J. Cook  
Ken L. Cooley  
Garth Corey

Dave M. Costyk  
William T. Crossland  
Bob Cunningham  
Zaher Daboussi  
Jeff Dagle  
James M. Daley  
Murray W. Davis  
Douglas C. Dawson  
Joseph Debs  
Charles DeCorse  
Michael de'Marsi  
David W. Dewis  
Peter Dick  
Paul A. Dolloff  
Kevin E. Donahoe  
David N. Dorsey  
Michael T. Doyle  
Per Drewes  
H. G. (Bert) Dreyer  
Roch Ducey  
Thomas Duffy  
Roger C. Dugan  
Kevin Duggan  
Mary Duggan  
John A. Duncan  
James Dunlop  
George A. Earle  
Stephen (Steve) E. Early  
Michael Edds  
Lynnda Ell  
James W. Ellars  
Daniel C. Engel  
Neil Engelman

Gary R. Engmann  
Thomas (Tom) W. Ernst  
Davis P. Erwin  
Mark Federle  
William E. Feero  
Barry Feldman  
Ralph Ferraro  
Bob Fick  
Tom Field  
Al Folkman  
Lou Fonte  
Harvey Forest  
Bryan R. Fox  
David Frank  
Christopher Freitas  
Paul J. Frey  
N. Richard (Dick) Friedman  
Lisa Gagnon  
Joseph (Joe) Galdo  
Susan Gardner  
Wayne Gardner  
Andris Garsils  
Bryan Gernet  
Patsy Geske  
Mark Gibson  
Rick Gilliam  
Thomas C. J. Gleason  
Manuel Gonzalez  
Daniel A. Goodrich  
Tom Gordon  
Charles Gougler  
Ed Grebel  
Tom Greely  
Jim (Herbert) Green  
George T. Gurlaskie  
J. H. Gurney  
Lance P. Haines  
Kenneth Hall  
Bruce Hamilton  
Kent M. Harmon  
Brent Harris  
Louis Harris  
Ronald D. Hartzel  
Kelvin Hecht  
Christy Herig  
Steve Hester  
Clark G. Hochgraf  
Earl W. Hodge  
John Hoffner  
Stephen Hogan  
Craig F. Holmes  
Donald L. Hornak  
Barry Hornberger  
Raymond M. Hudson  
Doug Hunchuk  
Michael J. Hyland  
Joe Iannucci  
Michael (Mike) R. Ibold  
Carl Imhoff  
Michael R. Ingram

Nicholas A. Ioannou  
Jim R. Iverson  
Robert W. Jackson  
Robert H. Jones  
Stephen R. Jones  
Hal Kamigaki  
William Kaszeta  
John R. Kennedy  
Scott A. Kenner  
Darrell Kent  
Greg Kern  
Thomas Key  
Carl Keyes  
Yuri Khersonsky  
Brendan Kirby  
Robb Klashner  
Kurt Klunder  
Brenon Knaggs  
Ljubomir A. Kojovic  
(Christopher) Todd Kollross  
Frank Kornbaum  
Burton Krakow  
Kenneth Krastins  
Jan F. Kreider  
Ben Kroposki  
Dale Krummen  
Steve Kuehl  
Richard (Rick) Langley  
Leonard E. Lansing  
Chris Larsen  
Bruce K. Larson  
Bob Laufenberg  
Schienbein Lawrence  
Eric Le Courtois  
Louis Lefevre  
James W. Lemke  
Kevin LeRow  
David Leslie  
Ted Lesster  
Jason Lin  
Richard W. Lincoln  
William E. Liss  
James Long  
Kevin P. Loving  
Don Lowenberg  
Carl C. Lower  
Andrew R. Macko  
Scott Malinowski  
Arshad Mansoor  
Sylvain Martel  
Anthony Mazy  
Jeff McElray  
Frank R. McElvain  
Tim McIntyre  
Mike McKeon  
Tron Melzl  
Michael (Mike) Michaud  
Alex Mikonowicz  
Tor-Eivind Moen  
Robert L. (Larry) Morgan

Allen G. Morinec  
Blake B. Morrison  
Jay Morrison  
David H. Munyan  
Terrence W. Mysak  
Gary Nakarado  
Chet Napikoski  
Arun Narang  
Jerry Neal  
Bradley D. (Brad)  
Nelson  
Kenneth E. Nicholson  
Gary L. Olson  
Ron Onate  
Fari Ordubadi  
Paul A. Orr  
Ernie Palomino  
David Park  
Alfred Pattmann  
Fang Zheng Peng  
Charles H. Perry  
Jeff Petter  
Philip A. Philippidis  
Michael Pincus  
Jeff G. Pope  
Edan Prabhu  
Stan Pukash  
Ronald Quick  
Ed Quiroz  
Kaushik Rajashekara  
John A. Raksany  
Gregory J. Ramon  
Jim Ranfone  
Jason N. Richards  
George Ritchie  
Raymond Roberge  
George Robinson  
Charles Rogers  
Matt Romanow  
Bob Rose  
Paul Russell  
Bob Saint  
Daniel P. Sammon  
Daniel Sandoval  
Juan S. Santos  
Mark Sardella  
William W. Saylor  
Vince Scaini  
Patrick (Pat) K. Scharff  
Joe E. Schatz  
Jason Schripsema  
Charles Schwartz  
Gary W. Scott  
Gary Seifert  
James Sember  
Edward C. Shaffer  
Michael T. Sheehan  
Kent Sheldon  
Richard Shiroma  
Larry Shockling

Georg A. Shultz  
Herbert J. Sinnock  
Andrew Skok  
David R. Smith  
Jeff Smith  
Allan D. St. Peter  
Wayne Stec  
William J. Steeley  
Ed Stein  
Jon D. Steinmetz  
Dehn A. Stevens  
John Stevens  
Robert Stewart  
William Stillinger  
Robert Stokes  
Todd M. Strothers  
John V. Stutsman  
Charles R. Sufana  
Chase Sun  
Len Swanson  
Craig Taborsky  
Sonal Talati  
Larry Tangel

Paula A. Taylor  
Dave Tewari  
Rao Thallam  
Tony Thorne  
Elisabeth (Betty) A. Tobin  
Sondra Todd  
Dennis Tollefson  
Jim Tomaseski  
Ed Torrero  
David L. Townley  
Glen Tubrett  
David Van Holde  
Mohammad Vaziri  
Jerry Ventre  
Harry Vollkommer  
Dan Walker  
Simon Wall  
Tim (Carl T.) Wall  
Reigh A. Walling  
Daniel (Dan) J. Ward  
Byron Washom  
James (Jim) Watts

Howard Wenger  
Randall (Randy) West  
Rick West  
Ron Westfall  
John S. Wheat  
Charles Whitaker  
Kent Whitfield  
Robert Wichert  
John Wiles  
Pat A. Wilkins  
Paul H. Williams  
Robert Wills  
Thomas Wind  
John Wohlgemuth  
Ronald Wolk  
Ronald Wong  
Murty V. V. S. Yalla  
Mike Yang  
Henry W. Zaininger  
Timothy P. Zgonena  
Richard Zhang  
Donald (Don) W. Zipse  
Luis Zubieta

The following working group members participated in finalizing the development of the standard with working group inputs, and in facilitating the development of those inputs throughout the standards development process:

William J. Ackerman  
Thomas S. Basso  
M. N. (Mac) Brodie  
Stephen P. Conrad  
James M. Daley  
Murray W. Davis  
Richard DeBlasio  
Paul A. Dolloff

Thomas Duffy  
Lynnda Ell  
Thomas (Tom) W. Ernst  
N. Richard (Dick) Friedman  
Frank Goodman  
Clark G. Hochgraf  
Joseph L. Koepfinger  
Robert L. (Larry) Morgan

Gary L. Olson  
Charles Rogers  
Gary Seifert  
Chase Sun  
Reigh A. Walling  
Charles Whitaker  
Robert Wichert  
Timothy P. Zgonena

The following members of the balloting committee voted on this standard. Balloters may have voted for approval, disapproval, or abstention.

William Ackerman  
Larry Adams  
John Adomaitis  
Martin Baier  
John Banting  
Philip P. Barker  
George Bartok  
David Bassett  
Thomas S. Basso  
Michael Behnke  
Kenneth Behrendt  
William J. Bergman  
Vijay Bhavaraju  
Kenneth Birt  
Steven Brockschink  
Malcolm Brodie  
Gustavo Brunello  
Michael Bui  
John Bzura  
Fernando Calderon

Mark Carpenter  
Robert Cary  
Carlos H. Castro  
Stephen Chalmers  
Jay Chamberlin  
Simon Cheng  
Frances M. Cleveland  
Joseph S. Collura  
Serge Comtois  
Larry Conrad  
Stephen Conrad  
William Cook  
Garth Corey  
David Costyk  
Zaher Daboussi  
Guru Dutt Dhingra  
Paul Drum  
James M. Daley  
Stephen Dare  
Murray Davis

Douglas Dawson  
Richard DeBlasio  
Joseph Debs  
Greg Dettmer  
Eugene Peter Dick  
W. B. Dietzman  
Paul Dolloff  
Kevin Donahoe  
David N. Dorsey  
Randall Dotson  
Michael Doyle  
Herbert (Bert) Dreyer  
Thomas Duffy  
George Earle  
Stephen Early  
Michael Edds  
Lynnda Ell  
Gary Engmann  
Thomas Ernst  
William Feero



Kenneth Fodero  
N. Richard Friedman  
Joseph Galdo  
Andris Garsils  
Manuel Gonzalez  
Frank Goodman  
Daniel Goodrich  
Tom Gordon  
Charles Gougler  
Ed Grebel  
Thomas Greely  
Jim Green  
Clayton Griffin  
Randall Groves  
George Gurlaskie  
James Gurney  
Lance Haines  
Kenneth Hall  
Ronald Hartzel  
Roger Hedding  
Steven Hensley  
Charles Henville  
Christy Herig  
Clark Hochgraf  
Stephen J. Hogan  
Jerry Hohn  
Donald Hornak  
Barry N. Hornberger  
James D. Huddleston, III  
Raymond Hudson  
Michael Hyland  
Robert W. Jackson  
Brian Johnson  
Robert H. Jones  
Rene Jonker  
Hardy King  
Hal Kamigaki  
Douglas Kay  
Ali Kazemi  
John Kennedy  
Thomas Key  
Yuri Khersonsky  
Brendan Kirby  
L. Brenon Knaggs  
Joseph L. Koepfinger  
Kenneth Krastins  
Edward Krizauskas  
Benjamin Kroposki  
John Kueck  
Gary Kuzkin  
Robert Landman  
Kevin LeRow  
Gerald Lee

Yeou-Song Lee  
Jim Lemke  
David Leslie  
Jason Lin  
Vahid Madani  
Faramarz Maghsoodlou  
T. Scott Malinowski  
Anthony Mazy  
Walter McCannon  
James McConnach  
John D. McDonald  
Michael McDonald  
Peter McNutt  
Nigel McQuin  
Christopher Melhorn  
Gary Michel  
Dean Miller  
Robert L. (Larry) Morgan  
Allen Morinec  
Pratap Mysore  
Raj Naidu  
George Nail  
Anthony Napikoski  
Arun Narang  
Bradley Nelson  
charles Ngethe  
Carl Niemann  
Daniel Nordell  
Gary L. Olson  
T. W. Olsen  
Fari Ordubadi  
Subhash Patel  
Michael Pehosh  
Robert Pettigrew  
Ralph Philbrook, III  
Philip Philippidis  
Stan Pukash  
Brian Purvis  
Ronald Quick  
Robert Rallo  
Jim Ranfone  
Raymond Roberge  
George E. Robinson  
Charles Rogers  
James Ruggieri  
Thomas Ruhlmann  
Bob Ryan  
Kuldip Sandhu  
Robert Saint  
Daniel Sammon  
Daniel Sandoval  
Steven Sano  
Gary W. Scott

Gary Seifert  
Michael Sheehan  
Richard Shiroma  
Larry Shockling  
Hong-Ming Shuh  
Tarlochan Sidhu  
Mark Siira  
H. Jin Sim  
Herbert Sinnock  
Veselin Skendzic  
Andrew Skok  
Allan St. Peter  
Wayne Stec  
Jon Steinmetz  
Kevin Stephan  
Dehn Stevens  
John Stevens  
Charles Sufana  
Chase Sun  
Leonard G. Swanson  
Craig Taborsky  
Richard P. Taylor  
John Tengdin  
Malcolm Thaden  
Rao Thallam  
Elisabeth Tobin  
Sondra Todd  
Dennis Tollefson  
Eric Udren  
Gerald Vaughn  
Mohammad Vaziri Yazdi  
Jane Ann Verner  
Charles Wagner  
Joseph Waligorski  
Carl T. Wall  
Simon Wall  
Reigh Walling  
Daniel J. Ward  
John Wardlow  
Cheryl Warren  
James Watts  
Randall West  
Ronald Westfall  
Chuck Whitaker  
Robert Wichert  
Robert Wills  
James Wilson  
Thomas Wind  
Philip Winston  
jonathan Woodworth  
Murty Yalla  
Timothy P. Zgonena  
Karl Zimmerman

When the IEEE-SA Standards Board approved this standard on 12 June 2003, it had the following membership:

**Don Wright, *Chair***  
**Howard M. Frazier, *Vice Chair***  
**Judith Gorman, *Secretary***

H. Stephen Berger  
Joe Bruder  
Bob Davis  
Richard DeBlasio  
Julian Forster\*  
Toshio Fukuda  
Arnold M. Greenspan  
Raymond Hapeman

Donald M. Heirman  
Laura Hitchcock  
Richard H. Hulett  
Anant Jain  
Lowell G. Johnson  
Joseph L. Koepfinger\*  
Tom McGean  
Steve Mills

Daleep C. Mohla  
William J. Moylan  
Paul Nikolich  
Gary Robinson  
Malcolm V. Thaden  
Geoffrey O. Thompson  
Doug Topping  
Howard L. Wolfman

\*Member Emeritus

Also included are the following nonvoting IEEE-SA Standards Board liaisons:

Alan Cookson, *NIST Representative*  
Satish K. Aggarwal, *NRC Representative*

Noelle D. Humenick  
*IEEE Standards Project Editor*

# Contents

1. Overview.....	1
1.1 Scope.....	1
1.2 Purpose.....	1
1.3 Limitations .....	2
2. References.....	2
3. Definitions and acronyms .....	3
3.1 Definitions .....	3
3.2 Acronyms.....	5
4. Interconnection technical specifications and requirements .....	5
4.1 General requirements .....	6
4.2 Response to Area EPS abnormal conditions.....	7
4.3 Power quality .....	9
4.4 Islanding.....	10
5. Interconnection test specifications and requirements .....	10
5.1 Design test.....	10
5.2 Production tests.....	13
5.3 Interconnection installation evaluation .....	14
5.4 Commissioning tests .....	14
5.5 Periodic interconnection tests .....	15
Annex A (informative) Bibliography .....	16

# IEEE Standard for Interconnecting Distributed Resources with Electric Power Systems

## 1. Overview

This standard provides interconnection technical specifications and requirements, and test specifications and requirements. Additionally, there is a bibliography included as Annex A that lists citations referred to in this standard for informative purposes, but that are not required to be used in conjunction with this standard.

### 1.1 Scope

This standard establishes criteria and requirements for interconnection of distributed resources (DR) with electric power systems (EPS).

### 1.2 Purpose

This standard provides a uniform standard for interconnection of distributed resources with electric power systems. It provides requirements relevant to the performance, operation, testing, safety considerations, and maintenance of the interconnection.

The requirements shall be met at the point of common coupling (PCC), although the devices used to meet these requirements can be located elsewhere. This standard applies to interconnection based on the aggregate rating of all the DR units that are within the Local EPS. The functions of the interconnection system hardware and software that affect the Area EPS are required to meet this standard regardless of their location on the EPS.

The stated specifications and requirements, both technical and testing, are universally needed for interconnection of DR, including synchronous machines, induction machines, or power inverters/converters, and will be sufficient for most installations.<sup>1</sup>

---

<sup>1</sup>Additional technical requirements and/or tests may be necessary for some limited situations.

## 1.3 Limitations

The criteria and requirements in this document are applicable to all distributed resource technologies, with aggregate capacity of 10 MVA or less at the PCC, interconnected to EPSs at typical primary and/or secondary distribution voltages. Installation of DR on radial primary and secondary distribution systems is the main emphasis of this standard, although installation of DR on primary and secondary network distribution systems is considered. This standard is written considering that the DR is a 60 Hz source.

- This standard does not define the maximum DR capacity for a particular installation that may be interconnected to a single PCC or connected to a given feeder.
- This standard does not prescribe DR self-protection or all operating requirements for DR units.
- This standard does not address planning, designing, operating, or maintaining the Area EPS.
- This standard does not apply to automatic transfer schemes in which load is transferred between the DR and the EPS in a momentary make-before-break operation provided the duration of paralleling the sources is less than 100 ms, except as noted in 4.1.4.

## 2. References

The following standards shall be used in conjunction with this standard. When the stated version of the following standards is superseded by an approved revision, then that revision shall apply.

The applicability of the following standards is determined by the specific requirements stated in this standard, such as requiring certain sections.

ANSI C84.1-1995, Electric Power Systems and Equipment—Voltage Ratings (60 Hz).<sup>2</sup>

IEEE Std C37.90.1<sup>TM</sup>-2002, IEEE Standard Surge Withstand Capability (SWC) Tests for Relays and Relay Systems Associated with Electric Power Apparatus.<sup>3,4</sup>

IEEE Std C37.90.2<sup>TM</sup>-1995, IEEE Standard Withstand Capability of Relay Systems to Radiated Electromagnetic Interference from Transceivers.

IEEE Std C62.41.2<sup>TM</sup>-2002, IEEE Recommended Practice on Characterization of Surges in Low Voltage (1000 V and less) AC Power Circuits.

IEEE Std C62.45<sup>TM</sup>-2002, IEEE Recommended Practice on Surge Testing for Equipment Connected to Low-Voltage (1000V and Less) AC Power Circuits.

NEMA MG 1-1998, Motors and Generators, Revision 2.<sup>5</sup>

---

<sup>2</sup>ANSI publications are available from the Sales Department, American National Standards Institute, 25 West 43rd Street, 4th Floor, New York, NY 10036, USA (<http://www.ansi.org/>).

<sup>3</sup>The IEEE standards or products referred to in Clause 2 are trademarks owned by the Institute of Electrical and Electronics Engineers, Incorporated.

<sup>4</sup>IEEE publications are available from the Institute of Electrical and Electronics Engineers, 445 Hoes Lane, P.O. Box 1331, Piscataway, NJ 08855-1331, USA (<http://standards.ieee.org/>).

<sup>5</sup>NEMA publications are available from Global Engineering Documents, 15 Inverness Way East, Englewood, Colorado 80112, USA (<http://global.ihs.com/>).

### 3. Definitions and acronyms

For purposes of this standard, the following terms and definitions apply. IEEE 100™, *The Authoritative Dictionary of IEEE Standards Terms*, Seventh Edition [B4],<sup>6</sup> should be referenced for terms not defined in this clause.

#### 3.1 Definitions

**3.1.1 area electric power system operator (Area EPS Operator):** The entity responsible for designing, building, operating, and maintaining the Area EPS.

**3.1.2 cease to energize:** Cessation of energy outflow capability.

**3.1.3 design test:** Test of one or more devices made to a certain design to show that the design meets certain specifications.

**3.1.4 distributed generation (DG):** Electric generation facilities connected to an Area EPS through a PCC; a subset of DR.

**3.1.5 distributed resources (DR):** Sources of electric power that are not directly connected to a bulk power transmission system. DR includes both generators and energy storage technologies.

NOTE—See Figure 1 and Figure 2.

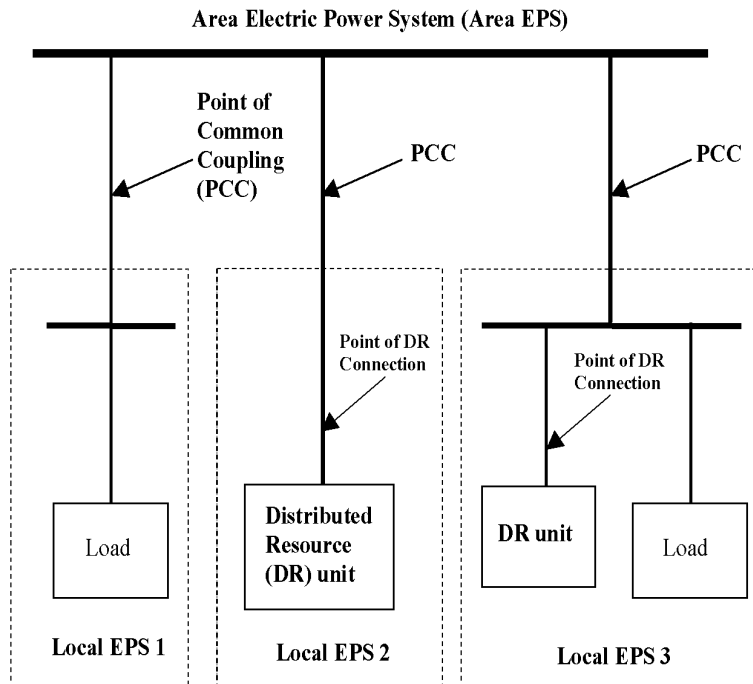

Note: Dashed lines are EPS boundaries. There can be any number of Local EPSs.

**Figure 1—Relationship of interconnection terms**

<sup>6</sup>The numbers in brackets correspond to those of the bibliography in Annex A.

**3.1.6 electric power system (EPS):** Facilities that deliver electric power to a load.

NOTE—This may include generation units. See Figure 1.

**3.1.6.1 electric power system, area (Area EPS):** An EPS that serves Local EPSs.

NOTE—Typically, an Area EPS has primary access to public rights-of-way, priority crossing of property boundaries, etc., and is subject to regulatory oversight. See Figure 1.

**3.1.6.2 electric power system, local (Local EPS):** An EPS contained entirely within a single premises or group of premises.

NOTE—See Figure 1.

**3.1.7 interconnection:** The result of the process of adding a DR unit to an Area EPS.

NOTE—See Figure 2.



**Figure 2—Schematic of interconnection**

**3.1.8 interconnection equipment:** Individual or multiple devices used in an interconnection system.

**3.1.9 interconnection system:** The collection of all interconnection equipment and functions, taken as a group, used to interconnect a DR unit(s) to an Area EPS.

NOTE—See Figure 2.

**3.1.10 inverter:** A machine, device, or system that changes direct-current power to alternating-current power.

**3.1.11 island:** A condition in which a portion of an Area EPS is energized solely by one or more Local EPSs through the associated PCCs while that portion of the Area EPS is electrically separated from the rest of the Area EPS.

**3.1.11.1 island, intentional:** A planned island.

**3.1.11.2 island, unintentional:** An unplanned island.

**3.1.12 non-islanding:** Intended to prevent the continued existence of an island.

**3.1.13 point of common coupling (PCC):** The point where a Local EPS is connected to an Area EPS.

NOTE—See Figure 1.

**3.1.14 point of distributed resources connection (point of DR connection):** The point where a DR unit is electrically connected in an EPS.

NOTE—See Figure 1.

**3.1.15 simulated utility:** An assembly of variable frequency and variable voltage test equipment used to simulate a normal utility source.

**3.1.16 total demand distortion (TDD):** The total root-sum-square harmonic current distortion, in percent of the maximum demand load current (15 or 30 minute demand).

**3.1.17 total rated-current distortion (TRD):** The total root-sum-square of the current harmonics created by the DR unit operating into a linear balanced load divided by the greater of the test load current demand ( $I_L$ ) or the rated current capacity of the DR unit ( $I_{\text{rated}}$ ).

## 3.2 Acronyms

Area EPS	Area electric power system
DG	distributed generation
DR	distributed resources
EPS	electric power system
I	current
$I_L$	load current
$I_{\text{SC}}$	short circuit current
Local EPS	Local electric power system
PCC	point of common coupling
TDD	total demand distortion
TRD	total rated-current distortion

## 4. Interconnection technical specifications and requirements

The requirements in this clause shall be met at the PCC, although the devices used to meet these requirements can be located elsewhere. The requirements apply to interconnection of either a single DR unit based on that unit's rating or multiple DR units within a single Local EPS, based on the aggregate rating of all the DR units that are within the Local EPS. The functions of the interconnection system hardware and software that affect the Area EPS are required to meet this standard regardless of their location on the EPS.

The requirements in this clause are functional and do not specify any particular equipment or equipment type.



The stated technical specifications and requirements are universally needed for interconnection of DR, including synchronous machines, induction machines, or static power inverters/converters, and will be sufficient for most installations.<sup>7</sup>

## **4.1 General requirements**

### **4.1.1 Voltage regulation**

The DR shall not actively regulate the voltage at the PCC. The DR shall not cause the Area EPS service voltage at other Local EPSs to go outside the requirements of ANSI C84.1-1995, Range A.

### **4.1.2 Integration with Area EPS grounding**

The grounding scheme of the DR interconnection shall not cause overvoltages that exceed the rating of the equipment connected to the Area EPS and shall not disrupt the coordination of the ground fault protection on the Area EPS.

### **4.1.3 Synchronization**

The DR unit shall parallel with the Area EPS without causing a voltage fluctuation at the PCC greater than  $\pm 5\%$  of the prevailing voltage level of the Area EPS at the PCC, and meet the flicker requirements of 4.3.2.

### **4.1.4 Distributed resources on distribution secondary grid and spot networks**

#### **4.1.4.1 Distribution secondary grid networks**

This topic is under consideration for future revisions of this standard.

#### **4.1.4.2 Distribution secondary spot networks<sup>8</sup>**

Network protectors shall not be used to separate, switch, serve as breaker failure backup or in any manner isolate a network or network primary feeder to which DR is connected from the remainder of the Area EPS, unless the protectors are rated and tested per applicable standards for such an application.<sup>9</sup>

Any DR installation connected to a spot network shall not cause operation or prevent reclosing of any network protectors installed on the spot network. This coordination shall be accomplished without requiring any changes to prevailing network protector clearing time practices of the Area EPS.

Connection of the DR to the Area EPS is only permitted if the Area EPS network bus is already energized by more than 50% of the installed network protectors.

The DR output shall not cause any cycling of network protectors.

The network equipment loading and fault interrupting capacity shall not be exceeded with the addition of DR.

---

<sup>7</sup>Additional technical requirements may be necessary for some limited situations.

<sup>8</sup>When required by the authority who has jurisdiction over the DR interconnection, a study may be conducted to determine that all of the requirements of this subclause can be met when the aggregate DR installed on a spot network exceeds 5% of the spot network's maximum load.

<sup>9</sup>IEEE C37.108<sup>TM</sup>-2002 [B8] and IEEE C57.12.44<sup>TM</sup>-2000 [B9] provide guidance on the capabilities of network systems to accept distributed resources.

DR installations on a spot network, using an automatic transfer scheme in which load is transferred between the DR and the EPS in a momentary make-before-break operation, shall meet all the requirements of this clause regardless of the duration of paralleling.

#### **4.1.5 Inadvertent energization of the Area EPS**

The DR shall not energize the Area EPS when the Area EPS is de-energized.

#### **4.1.6 Monitoring provisions**

Each DR unit of 250 kVA or more or DR aggregate of 250 kVA or more at a single PCC shall have provisions for monitoring its connection status, real power output, reactive power output, and voltage at the point of DR connection.

#### **4.1.7 Isolation device**

When required by the Area EPS operating practices, a readily accessible, lockable, visible-break isolation device shall be located between the Area EPS and the DR unit.

#### **4.1.8 Interconnect integrity**

##### **4.1.8.1 Protection from electromagnetic interference**

The interconnection system shall have the capability to withstand electromagnetic interference (EMI) environments in accordance with IEEE Std C37.90.2-1995. The influence of EMI shall not result in a change in state or misoperation of the interconnection system.

##### **4.1.8.2 Surge withstand performance**

The interconnection system shall have the capability to withstand voltage and current surges in accordance with the environments defined in IEEE Std C62.41.2-2002 or IEEE Std C37.90.1-2002 as applicable.

##### **4.1.8.3 Paralleling device**

The interconnection system paralleling-device shall be capable of withstanding 220% of the interconnection system rated voltage.

### **4.2 Response to Area EPS abnormal conditions<sup>10</sup>**

Abnormal conditions can arise on the Area EPS that require a response from the connected DR. This response contributes to the safety of utility maintenance personnel and the general public, as well as the avoidance of damage to connected equipment, including the DR. All voltage and frequency parameters specified in these subclauses shall be met at the PCC, unless otherwise stated.

#### **4.2.1 Area EPS faults**

The DR unit shall cease to energize the Area EPS for faults on the Area EPS circuit to which it is connected.

---

<sup>10</sup>The isolation of a portion of the Area EPS, presenting the potential for an unintended DR island, is a special concern and is addressed in 4.4.1.

Setting adjustments may only be made as approved by the authority who has jurisdiction over the DR interconnection.

#### 4.2.2 Area EPS reclosing coordination

The DR shall cease to energize the Area EPS circuit to which it is connected prior to reclosure by the Area EPS.

#### 4.2.3 Voltage

The protection functions of the interconnection system shall detect the effective (rms) or fundamental frequency value of each phase-to-phase voltage, except where the transformer connecting the Local EPS to the Area EPS is a grounded wye-wye configuration, or single-phase installation, the phase-to-neutral voltage shall be detected. When any voltage is in a range given in Table 1, the DR shall cease to energize the Area EPS within the clearing time as indicated. Clearing time is the time between the start of the abnormal condition and the DR ceasing to energize the Area EPS. For DR less than or equal to 30 kW in peak capacity, the voltage set points and clearing times shall be either fixed or field adjustable. For DR greater than 30 kW, the voltage set points shall be field adjustable.

The voltages shall be detected at either the PCC or the point of DR connection when any of the following conditions exist:

- a) The aggregate capacity of DR systems connected to a single PCC is less than or equal to 30 kW,
- b) The interconnection equipment is certified to pass a non-islanding test for the system to which it is to be connected,
- c) The aggregate DR capacity is less than 50% of the total Local EPS minimum annual integrated electrical demand for a 15 minute time period, and export of real or reactive power by the DR to the Area EPS is not permitted.

**Table 1—Interconnection system response to abnormal voltages**

Voltage range (% of base voltage <sup>a</sup> )	Clearing time(s) <sup>b</sup>
$V < 50$	0.16
$50 \leq V < 88$	2.00
$110 < V < 120$	1.00
$V \geq 120$	0.16

<sup>a</sup>Base voltages are the nominal system voltages stated in ANSI C84.1-1995, Table 1.

<sup>b</sup>DR  $\leq$  30 kW, maximum clearing times; DR > 30kW, default clearing times.

#### 4.2.4 Frequency

When the system frequency is in a range given in Table 2, the DR shall cease to energize the Area EPS within the clearing time as indicated. Clearing time is the time between the start of the abnormal condition and the DR ceasing to energize the Area EPS. For DR less than or equal to 30 kW in peak capacity, the frequency set points and clearing times shall be either fixed or field adjustable. For DR greater than 30 kW, the frequency set points shall be field adjustable.

Adjustable under-frequency trip settings shall be coordinated with Area EPS operations.

**Table 2—Interconnection system response to abnormal frequencies**

DR size	Frequency range (Hz)	Clearing time(s) <sup>a</sup>
≤ 30 kW	> 60.5	0.16
	< 59.3	0.16
> 30 kW	> 60.5	0.16
	< {59.8 – 57.0} (adjustable set point)	Adjustable 0.16 to 300
	< 57.0	0.16

<sup>a</sup>DR ≤ 30 kW, maximum clearing times; DR > 30 kW, default clearing times.

#### 4.2.5 Loss of synchronism

Loss of synchronism protection is not required except as necessary to meet 4.3.2.

#### 4.2.6 Reconnection to Area EPS

After an Area EPS disturbance, no DR reconnection shall take place until the Area EPS voltage is within Range B of ANSI C84.1-1995, Table 1, and frequency range of 59.3 Hz to 60.5 Hz.

The DR interconnection system shall include an adjustable delay (or a fixed delay of five minutes) that may delay reconnection for up to five minutes after the Area EPS steady-state voltage and frequency are restored to the ranges identified above.

### 4.3 Power quality

#### 4.3.1 Limitation of dc injection

The DR and its interconnection system shall not inject dc current greater than 0.5% of the full rated output current at the point of DR connection.

#### 4.3.2 Limitation of flicker induced by the DR

The DR shall not create objectionable flicker for other customers on the Area EPS.<sup>11</sup>

#### 4.3.3 Harmonics

When the DR is serving balanced linear loads, harmonic current injection into the Area EPS at the PCC shall not exceed the limits stated below in Table 3. The harmonic current injections shall be exclusive of any harmonic currents due to harmonic voltage distortion present in the Area EPS without the DR connected.

<sup>11</sup>Flicker is considered objectionable when it either causes a modulation of the light level of lamps sufficient to be irritating to humans, or causes equipment misoperation. For guidance, refer to IEEE Std 519<sup>TM</sup>-1992 [B5], IEEE P1453<sup>TM</sup> [B10], IEC/TR3 61000-3-7 [B1], IEC 61000-4-15 [B2], IEC 61400-21 [B3].

**Table 3—Maximum harmonic current distortion in percent of current (I)<sup>a</sup>**

Individual harmonic order $h$ (odd harmonics) <sup>b</sup>	$h < 11$	$11 \leq h < 17$	$17 \leq h < 23$	$23 \leq h < 35$	$35 \leq h$	Total demand distortion (TDD)
Percent (%)	4.0	2.0	1.5	0.6	0.3	5.0

<sup>a</sup>  $I$  = the greater of the Local EPS maximum load current integrated demand (15 or 30 minutes) without the DR unit, or the DR unit rated current capacity (transformed to the PCC when a transformer exists between the DR unit and the PCC).

<sup>b</sup> Even harmonics are limited to 25% of the odd harmonic limits above.

## 4.4 Islanding

### 4.4.1 Unintentional islanding

For an unintentional island in which the DR energizes a portion of the Area EPS through the PCC, the DR interconnection system shall detect the island and cease to energize the Area EPS within two seconds of the formation of an island.<sup>12</sup>

### 4.4.2 Intentional islanding

This topic is under consideration for future revisions of this standard.

## 5. Interconnection test specifications and requirements

This clause provides the test requirements to demonstrate that the interconnection system meets the requirements of Clause 4. The applicable tests from this clause are required for all interconnection systems. The results of these tests shall be formally documented.

The stated test specifications and requirements are universally needed for interconnection of DR including synchronous machines, induction machines, or static power inverters/converters, and will be sufficient for most installations.<sup>13</sup>

### 5.1 Design test

This design test shall be performed as applicable to the specific interconnection system technology. The test shall be performed on a representative sample, either in the factory, at a testing laboratory, or on equipment in the field.<sup>14</sup>

<sup>12</sup>Some examples by which this requirement may be met are:

1. The DR aggregate capacity is less than one-third of the minimum load of the Local EPS.
2. The DR is certified to pass an applicable non-islanding test.
3. The DR installation contains reverse or minimum power flow protection, sensed between the Point of DR Connection and the PCC, which will disconnect or isolate the DR if power flow from the Area EPS to the Local EPS reverses or falls below a set threshold.
4. The DR contains other non-islanding means, such as a) forced frequency or voltage shifting, b) transfer trip, or c) governor and excitation controls that maintain constant power and constant power factor.

<sup>13</sup>Additional tests may be necessary for some limited situations.

<sup>14</sup>The design test of 5.1 may be adopted as the testing basis for certification of interconnection systems.

This test applies to a packaged interconnection system using embedded components or to an interconnection system that uses an assembly of discrete components.

The design test shall be conducted on the same sample in the sequence of Table 4.

**Table 4—Sequence for conducting design test**

Required order	Design test clause and title
1	5.1.1 Response to abnormal voltage and frequency
2	5.1.2 Synchronization
3	5.1.3 Interconnect integrity test
<b>Suggested order</b>	
4	5.1.1 Response to abnormal voltage and frequency
5	5.1.2 Synchronization
6	5.1.4 Unintentional islanding
7	5.1.5 Limitation of dc injection
8	5.1.6 Harmonics

### 5.1.1 Response to abnormal voltage and frequency

This test shall demonstrate that the DR ceases to energize the Area EPS when the voltage or frequency exceeds the limits as specified in 4.2.3 and 4.2.4. Interconnection systems provided with field adjustable set points shall also be tested at the minimum, midpoint, and maximum of the adjustable set point ranges. These tests shall be conducted using either the simulated utility or secondary injection method.

### 5.1.2 Synchronization

Test results conforming to requirements of A, B, or C below are accepted as indicating compliance with the requirements of 4.1.3. The appropriate conditions to be met for specific interconnection system technology follow.

#### A. Synchronous interconnection to an EPS, or an energized local EPS to an energized Area EPS

This test shall demonstrate that at the moment of the paralleling-device closure, all three parameters in Table 5 are within the stated ranges. This test shall also demonstrate that if any of the parameters are outside of the ranges stated in the table, the paralleling-device shall not close.

#### B. Induction interconnection

Self-excited induction generators shall be tested as per A in 5.1.2.

This test shall determine the maximum start-up (in-rush) current drawn by the unit.<sup>15</sup> The results shall be used, along with Area EPS impedance information for the proposed location, to estimate the starting voltage

<sup>15</sup>NEMA MG 1-1998 contains an acceptable method for determining inrush current.

**Table 5—Synchronization parameter limits for synchronous interconnection to an EPS, or an energized local EPS to an energized Area EPS**

Aggregate rating of DR units (kVA)	Frequency difference ( $\Delta f$ , Hz)	Voltage difference ( $\Delta V$ , %)	Phase angle difference ( $\Delta \Phi$ , °)
0 – 500	0.3	10	20
> 500 – 1 500	0.2	5	15
> 1 500 – 10 000	0.1	3	10

drop and verify that the unit shall not exceed the synchronization requirements in 4.1.3 and the flicker requirements in 4.3.2.

### C. Inverter interconnection<sup>16</sup>

An inverter-based interconnection system that produces fundamental voltage before the paralleling device is closed shall be tested according to the procedure for synchronous interconnection as stated in A of 5.1.2.

All other inverter-based interconnection systems shall be tested to determine the maximum start-up current. The results shall be used, along with Area EPS impedance for the proposed location, to estimate the starting voltage magnitude change and verify that the unit shall meet the synchronization requirements in 4.1.3 and the flicker requirements in 4.3.2.

### 5.1.3 Interconnect integrity test

#### 5.1.3.1 Protection from EMI

The interconnection system shall be tested in accordance with IEEE Std C37.90.2-1995 to confirm that the results are in compliance with 4.1.8.1. The influence of EMI shall not result in a change in state or mis-operation of the interconnection system.

#### 5.1.3.2 Surge withstand performance

The interconnection system shall be tested for the requirement in 4.1.8.2 in all normal operating modes in accordance with IEEE Std C62.45-2002 for equipment rated less than 1000 V to confirm that the surge withstand capability is met by using the selected test level(s) from IEEE Std C62.41.2-2002. Interconnection system equipment rated greater than 1000 V shall be tested in accordance with manufacturer or system integrator designated applicable standards. For interconnection system equipment signal and control circuits, use IEEE Std C37.90.1-2002. The results of these tests shall indicate the unit did not fail, did not mis-operate, and did not provide misinformation.

#### 5.1.3.3 Paralleling device

A dielectric test across the open-circuited paralleling device shall be conducted to confirm compliance with the requirements of 4.1.8.3.

### 5.1.4 Unintentional Islanding

A test or field verification shall be conducted to confirm that 4.4.1 is met regardless of the selected method of detecting isolation.<sup>17</sup>

<sup>16</sup>Some inverter-based interconnection systems may need to be tested to both requirements of C in 5.1.2.

### 5.1.5 Limitation of dc injection

Inverter based DR shall be tested to confirm that the DR does not inject dc current greater than prescribed limits that are listed in 4.3.1.

### 5.1.6 Harmonics

The intent of the harmonics interconnection test is to assess that under a controlled set of conditions the DR unit meets the harmonic limits specified in 4.3.3.

The DR shall be operated in parallel with a predominantly inductive voltage source with a short circuit current capacity  $I_{SC}$  of not less than 20 times the DR rated output current at fundamental frequency. The voltage and frequency output of the voltage source shall correspond to the rated voltage and frequency of the DR. The unloaded voltage waveform produced by the Area EPS or simulated utility voltage source shall have a total harmonic distortion (THD) less than 2.5%.

The DR shall be operated at an output test load current,  $I_L$ , of 33%, 66%, and at a level as close to 100% of rated output current as practical. Use total rated-current distortion (TRD) in place of TDD. TRD is the total rms value of the sum of the current harmonics created by the DR unit operating into a linear balanced load divided by the greater of the test load current ( $I_L$ ) demand or the rated current capacity of the DR unit ( $I_{rated}$ ). The individual harmonic distortion and TRD of the DR output current shall be measured for the first 40 harmonics. The harmonic current injections shall be exclusive of any harmonic currents due to harmonic voltage distortion present in the Area EPS without the DR connected. The test results shall not exceed the values in 4.3.3, Table 3.<sup>18</sup>

As an alternative, a synchronous generator DR shall be tested to meet the requirements of 4.3.3; either after installation or while powering a balanced resistive load and isolated from any other sources. The voltage harmonics while powering a resistive load at 100% of the machine kVA rating shall not exceed the levels in Table 6. Voltage harmonics shall be measured line to line for 3-phase/3 wire systems, and line to neutral for 3-phase/4-wire systems.

**Table 6—Maximum harmonic voltage distortion in percent of rated voltage for synchronous machines**

Individual harmonic order	$h < 11$	$11 \leq h < 17$	$17 \leq h < 23$	$23 \leq h < 35$	$35 \leq h$	Total harmonic distortion
Percent (%)	4.0	2.0	1.5	0.6	0.3	5.0

## 5.2 Production tests

Each interconnection system shall be subjected to requirements of 5.1.1 and 5.1.2. Interconnection systems with adjustable set points shall be tested at a single set of set points as specified by the manufacturer. This test may be conducted as a factory test or may be performed as part of a commissioning test (see 5.4).

<sup>17</sup>An example test is in UL 1741 [B14].

<sup>18</sup>These values or lower values may be required to meet the TDD of 5% at the PCC.



## 5.3 Interconnection installation evaluation

### 5.3.1 Grounding integration with Area EPS

A system design verification shall be made to ensure that the requirements of 4.1.2 have been met.

### 5.3.2 Isolation device

A system design verification shall be made to ensure that the requirements of 4.1.7 have been met.

### 5.3.3 Monitoring provisions

A system design verification shall be made to ensure that the provisions for monitoring are in accordance with 4.1.6.

### 5.3.4 Area EPS faults

A system design verification shall be made to ensure that the requirements of 4.2.1 have been met.

### 5.3.5 Area EPS reclosing coordination

A system design verification shall be made to verify the interconnection system is coordinated with the Area EPS reclosing practices in accordance with 4.2.2.

## 5.4 Commissioning tests

All commissioning tests shall be performed based on written test procedures.<sup>19</sup> The following visual inspections shall be performed.

- A visual inspection shall be made to ensure that the grounding coordination requirement of 4.1.2 has been implemented.
- A visual inspection shall be made to confirm the presence of the isolation device if required by 4.1.7.

Initial commissioning tests shall be performed on the installed DR and interconnection system equipment prior to the initial parallel operation of the DR. The following tests are required:

- Operability test on the isolation device
- Unintentional-islanding functionality as specified in 5.4.1
- Cease to energize functionality as specified in 5.4.2
- Any tests of 5.1 that have not been previously performed on a representative sample and formally documented
- Any tests of 5.2 that have not been previously performed

The applicable tests of 5.1 shall be repeated when:

- Functional software or firmware changes have been made on the interconnection system
- Any hardware component of the interconnection system has been modified in the field, or, replaced or repaired with parts different from the tested configuration.

Subclauses 5.4.1 and 5.4.2, and the applicable tests of 5.2 shall be repeated if:

---

<sup>19</sup>Test procedures are commonly provided by equipment manufacturer(s) or system integrator(s) and approved by the equipment owner and Area EPS operator.

- Protection settings have been changed after factory testing.
- Protection functions have been adjusted after the initial commissioning process.

#### **5.4.1 Unintentional islanding functionality test**

##### **5.4.1.1 Reverse-power or minimum power test**

A reverse-power or minimum power function, if used to meet the requirements of 4.4.1, shall be tested using injection techniques or by adjusting the DR output and local loads to verify that the reverse power or minimum power function is met.

##### **5.4.1.2 Non-islanding functionality test**

For non-islanding interconnection systems, 5.4.2 satisfies this requirement.

##### **5.4.1.3 Other unintentional islanding functionality tests**

If tests in 5.4.1.1 and 5.4.1.2 are not applicable to the interconnection system, the interconnection system shall be tested in accordance with procedures provided by the manufacturer or system integrator.

##### **5.4.2 Cease to energize functionality test**

Check the cease to energize functionality by operating a load interrupting device and verify the equipment ceases to energize its output terminals and does not restart/reconnect for the required time delay. The test shall be performed on each phase individually. This test verifies conformance to the cease to energize requirement of 4.1.4, 4.2.1, 4.2.2, 4.2.3, 4.2.4, and 4.4.1.

#### **5.5 Periodic interconnection tests**

All interconnection-related protective functions and associated batteries shall be periodically tested at intervals specified by the manufacturer, system integrator, or the authority who has jurisdiction over the DR interconnection. Periodic test reports or a log for inspection shall be maintained.

## Annex A

(informative)

### Bibliography

The following citations are referred to in this standard for informative purposes and are not required to be used in conjunction with this standard.

[B1] IEC TR3 61000-3-7, Assessment of Emission Limits for Fluctuating Loads in MV and HV Power Systems.

[B2] IEC 61000-4-15, Flickermeter—Functional and Design Specifications.

[B3] IEC 61400-21, Wind Turbine Generator Systems—Part 21: Measurement and Assessment of Power Quality Characteristics of Grid Connected Wind Turbines—Ed. 1.0 (2001-12).

[B4] IEEE 100, *The Authoritative Dictionary of IEEE Standards Terms*, Seventh Edition, New York, Institute of Electrical and Electronics Engineers, Inc.

[B5] IEEE Std 519-1992, IEEE Recommended Practices and Requirements for Harmonic Control in Electrical Power Systems.<sup>20</sup>

[B6] IEEE Std 929<sup>TM</sup>-2000, IEEE Recommended Practice for Utility Interface of Photovoltaic (PV) Systems.

[B7] IEEE Std 1001<sup>TM</sup>-1988, IEEE Guide for Interfacing Dispersed Storage and Generation Facilities with Electric Utility Systems.

[B8] IEEE Std C37.108-1989 (R2002), IEEE Guide for the Protection of Network Transformers.

[B9] IEEE Std C57.12.44-2000, IEEE Standard Requirements for Secondary Network Protectors.

[B10] IEEE P1453, Draft Recommended Practice for Measurement and Limits of Voltage Flicker on AC Power Systems.

[B11] IEEE P1547.1<sup>TM</sup>, Draft Standard For Conformance Test Procedures for Equipment Interconnecting Distributed Resources with Electric Power Systems.

[B12] IEEE P1547.2<sup>TM</sup>, Draft Application Guide for IEEE Std 1547-2003, IEEE Standard for Interconnecting Distributed Resources with Electric Power Systems.

[B13] IEEE P1547.3<sup>TM</sup>, Draft Guide for Monitoring, Information Exchange, and Control of Distributed Resources Interconnected with Electric Power Systems.

[B14] UL 1741, Inverters, Converters, and Controllers for Use in Independent Power Systems.

---

<sup>20</sup>The IEEE standards or products referred to in Annex A are trademarks owned by the Institute of Electrical and Electronics Engineers, Incorporated.