

BEFORE THE
WASHINGTON UTILITIES & TRANSPORTATION COMMISSION

UW-240151

CASCADIA WATER, LLC

September 26, 2024

Direct Exhibit of Culley J. Lehman

UNDERWATER INSPECTION REPORT OF PROCEDURES AND FINDINGS

Exh. CJL-4



Report of Procedures and Findings

From Internal, Underwater Inspection
of
Estates 2
for
Estates/Monterra/Dungeness WS Inc.
by



711 Market Street, Klamath Falls, OR 97601, (800) 229-6959 www.divingservices.com

This Page Intentionally Left Blank



LiquiVISION TECHNOLOGY

D I V I N G S E R V I C E S

Office/Mailing Address
711 Market Street
Klamath Falls, OR 97601
www.divinaservices.com

Western Operations
835 Market Street
Klamath Falls, OR 97601

Eastern Operations
1420 Spring Street #12
Jeffersonville, IN 47130
liquivision@divinaservices.com

Toll Free: (800) 229-8959
Phone: (541) 883-6473
Fax: (541) 883-1361

January 15, 2007

Eric Thomas
Estates/Monterra/Dungeness WS Inc.
PO Box 531
Sequim, WA 98382

Underwater Inspection of Estates 2

Following is a report of findings during the underwater inspection of your reservoir.

We keep our reports concise and brief. It will focus on issues of concern or areas that need attention. In order to see complete and detailed inspections please view each inspection video. We will give you our recommendations of actions that can be taken to improve areas of concern.

Color images of all areas that may be of concern or features of interest were taken via underwater digital camera. The images should give you a clear view of the conditions described. The video may give you another view and better understanding of any area that you may wish to look at more closely. The video recorded the images as they were taken in the order presented here. This allows easy reference between the video and inspection images.

METHODOLOGY:

The following specifications and purpose for each have been adopted by LVT as standards that are necessary to competently and safely perform dive operations in potable water tanks. All of these standards were utilized during the inspection of your reservoir.

Require Divers to use Dedicated Dry-Suits Made of a Material Suitable for Disinfection:
ANSI/AWWA Standard. Prevents contamination of water. Diver's body does not come in contact with water. The only material suitable for disinfection is vulcanized rubber. Neoprene or shell dry suits are too porous for rapid chemical disinfection.

Use of Dry Commercial Diving Hard Hat: The commercial diving hard hat keeps the Diver's head and neck from having any contact with the water column. It prevents the diver from contaminating the water with saliva or mucous from his sinuses and/or nasal passages. It prevents any contamination of the water from sweat, skin, hair, or associated microorganisms found on the diver's body. Use of surface supplied air without hard hat (helmet) is unacceptable because saliva and mucous will escape through regulator and mask.

Estates 2

Beyond contamination issues a hard hat allows the diver to have full-time reliable voice communication. This is possible due to the fact that the diver does not have to hold a regulator mouthpiece between his teeth and his head is in an air pocket. Therefore, the microphone and speakers mounted inside the hard hat are as functional as they would be out of the water. Another advantage of the hard hat is that it allows for mounting of a video camera and lights. This allows the diver to video all work being accomplished.

External or Surface Air Supply: OSHA requires that surface air supply operations have two back up air sources. One is on site back up and the second is a diver carried reserve. LVT divers have a primary air source and two backup air sources. The primary air source is a gasoline engine driven compressor. The first backup air supply is comprised of two high pressure cylinders in the dive support trailer, which hold approximately 8 hours of air. The second emergency air backup is a small cylinder carried on the diver's back called a "bailout bottle". In the unlikely event that the diver finds himself without air he can manually turn on the bail out air supply, which provides enough air to safely exit the reservoir.

Disinfection of All Equipment With 200ppm+ Chlorine Immediately Prior to Entering System: This process Prevents contamination of water. All LVT equipment is properly disinfected prior to entering potable water.

Three Man Dive Team: In all instances a minimum three-man dive team is specifically required. If two divers are submerged then a five-man team is required. All dive team members must meet commercial training and/or experience requirements.

Full-Time Reliable Voice Communication between surface and Diver: The system allows for constant communication between the diver, and all surface personnel. The diver, dive controller in the support vehicle and the dive tender at the reservoir entrance point can communicate with each other at all times. In addition, customers can communicate with the diver at any time. It is apparent that full time communication with the diver is an important safety factor. But for purposes of a more efficient inspection, cleaning, and repair program this enables the diver to immediately discuss any observations he makes inside the reservoir. This is important when considering how difficult it is to pinpoint a specific area when inside a large water tank.

Because of constant communication with surface personnel and constant video viewing it is easy to locate and identify the observations made by the diver. It also saves a great deal of time and money when the utility staff can tell the diver how to deal with an extraordinary problem while the diver is there and able to perform the task at that moment.

Full time voice communication also allows for, and is the only way to have, accurate live voice input on video when recording.

Full-Time Live High Resolution Color Video: Allows for constant viewing of diver's work and observations. This has apparent safety considerations, but helps most when evaluating the work accomplished inside the reservoir. It is impossible for the diver to do a haphazard job or cause turbidity in the water column while he is under constant visual scrutiny. If a contractor cleans a reservoir without live video and then goes back and video records the interior subsequent to the work, it is impossible to tell whether the entire reservoir is being observed on the tape or how much sediment was stirred up into the water during the cleaning process. Regardless of how good a persons memory is, it is difficult to remember the details of the inside of a reservoir after spending as much as 8 or more hours cleaning it and then returning to video record the results and later

Estates 2

adding voice narration to explain what is on the silent video record. That is why LVT uses full-time, live video with full-time voice communication that is recorded simultaneously with the visual record. It is also important that the video camera is high resolution and that it have infinite focus.

TERMINOLOGY:

When describing the features or areas of interest inside the reservoir an image number is placed next to the description that corresponds with the inspection findings. At the end of the overview section a diagram is shown in a view looking from the top down. The diagram is shown with the entry hatch at the top, and this will be referred to as the 12:00 position.

Following the diagram are pictures of the pertinent areas of the reservoir and most of the locations that were inspected. Each picture is numbered and corresponds with the descriptions in the overview section. For more detail please refer to the time stamp on the picture and watch the video.

Following the picture section are references and definitions of the standards used during the inspection of your reservoir. These standards include: Standard Method of Evaluating Degree of Rusting on Painted Steel Surfaces – SSPC-Vis 2-82 & ASTM D 610-85 (1989), Cathodic Protection Definitions – NACE Standard RP0196-96 & RP0388-2001, Weld Surface Conditions - AWS B1.11: 2000 (An American National Standard), and Concrete Deformities Definitions – ACI 201.1R-92.

Estates 2

OVERVIEW OF RESERVOIR INSPECTED:

Customer Name: Estates/Monterra/Dungeness WS Inc.	Reservoir Name: Estates 2
Manager: Eric Thomas	Construction: BG Concrete
Job Number: WA1409006R4T3	Capacity (gal.): 146,608
Date of Inspection: January 15, 2007	Diameter or L x W: 35' X 70'
Report Writer: Brett Williams	Height: 8'
Diver: Richard Peterson	Floor Square FT: 2,450'
Tender: Cameron Hagerman	Date Built: Unknown

N/A –not applicable **Excellent** (Ex.) –like new condition, no repairs needed. **Good** – Cosmetic only problems, repairs if wanted. **Fair**- Minor problems, repairs needed, not immediate. **Poor** –Major problems, structural or like, immediate repairs needed.

Component	Condition				Pic. #s	Comments
	NA	Ex.	Good	Fair Poor		
Site Security			X			Tank is in residential area with entrance to hatch in locked building.
Reservoir Exterior						Appeared to be in good condition.
<i>1st Ring Wall</i>			X		1	Concrete Deform. ⁴ <u>GC.</u>
<i>Top Ring Wall</i>			X			Concrete Deform. ⁴ <u>GC.</u>
Exterior Roof						Appeared to be in good condition with minor surface cracking.
<i>Roof North</i>			X			Concrete Deform. ⁴ <u>GC.</u>
<i>Roof East</i>			X		4	Concrete Deform. ⁴ <u>GC.</u>
<i>Roof South</i>			X			Concrete Deform. ⁴ <u>GC.</u>
<i>Roof West</i>			X		2	Concrete Deform. ⁴ <u>GC.</u>
<i>Roof Center</i>			X			Concrete Deform. ⁴ <u>GC.</u>
Roof Vents			X		3	Rust Grade ² <u>7.</u>
Exterior Telemetry			X		7	Appeared to be in good condition.
Exterior Inlet			X		10	Rust Grade ² <u>9.</u>
Exterior Outlet			X		8,9	Rust Grade ² <u>9.</u>
Exterior Overflow			X		6	Rust Grade ² <u>10.</u>

Estates 2

Component	Condition				Pic. # ^s	Comments
	NA	Ex.	Good	Fair		
Entry Hatch			X		5	Rust Grade ² <u>10.</u>
Telemetry Sensor			X		12	Appeared to be in good condition.
Interior Walls						Appeared to be in good condition with heavy staining that could not be removed with LiquiVac.
<i>1st Ring Wall</i>			X		19,25	Concrete Deform. ⁴ <u>GC.</u>
Interior Floor						Appeared to be in good condition.
<i>Floor North</i>			X			Concrete Deform. ⁴ <u>GC.</u>
<i>Floor East</i>			X		18	Concrete Deform. ⁴ <u>GC.</u>
<i>Floor South</i>			X			Concrete Deform. ⁴ <u>GC.</u>
<i>Floor West</i>			X		24	Concrete Deform. ⁴ <u>GC.</u>
<i>Floor Center</i>			X		20	Concrete Deform. ⁴ <u>GC.</u>
Support Columns						Appeared to be in good condition with minor cracking.
<i>Center Baffle Wall</i>				X	21	Concrete Deform. ⁴ <u>GC CK.</u>
Interior Overflow Pipe			X		27	Rust Grade ² <u>10.</u>
Interior Inlet			X		15,22	Rust Grade ² <u>10.</u>
Interior Crossover			X		17,26	Rust Grade ² <u>10.</u>
Interior Outlet			X		13,14	Rust Grade ² <u>9.</u>
Interior Slump			X		11	Rust Grade ² <u>9.</u>
Interior Ceiling						Appeared to be in good condition with minor cracking
<i>Ceiling North</i>			X		23	Concrete Deform. ⁴ <u>GC CK.</u>
<i>Ceiling East</i>			X			Concrete Deform. ⁴ <u>GC.</u>
<i>Ceiling South</i>			X		16	Concrete Deform. ⁴ <u>GC.</u>
<i>Ceiling West</i>			X			Concrete Deform. ⁴ <u>GC.</u>
<i>Ceiling Center</i>			X			Concrete Deform. ⁴ <u>GC.</u>
Other/Repair						
Other/Repair						
Other/Repair						

Estates 2

1. Coating thickness readings are in mils. (39.37 mils = 1 millimeter)

2. Rust Grades

Grades	% of Surface Rusted	Description
10	0% - 0.01%	No rusting or less than 0.01% of surface rusted
9	0.01% - 0.03%	Minute rusting, less than 0.03% of surface rusted
8	0.03% - 0.1%	Few isolated rust spots, less than 0.1% of surface rusted
7	0.1% - 0.3%	Less than 0.3% of surface rusted
6	0.3% - 1%	Extensive rust spots, but less than 1% of surface rusted
5	1% - 3%	Rusting to the extent of 3% of surface rusted
4	3% - 10%	Rusting to the extent of 10% of surface rusted
3	10% - 16%	Approximately one sixth of the surface rusted (16%)
2	16% - 33%	Approximately one third of the surface rusted (33%)
1	33% - 50%	Approximately one half of the surface rusted (50%)
0	50% - 100%	Approximately 100% of the surface rusted

3. Weld Deformities

Unable to Evaluate	Good Condition	Porosity	Incomplete Fusion	Incomplete Penetration	Undercut	Underfill	Overlap	Cracks	Convexity / Concavity	Spatter
UE	GC	PS	IF	IP	UC	UF	OL	CK	CC	SP

4. Concrete Deformities

Unable to Evaluate	Good Condition	Cracks	Blistering	Chalking	De-Lamination	Pitting	Popouts	Scaling	Spalling	Warping
UE	GC	CK	BL	CH	DL	PT	PO	SC	SP	WA

Estates 2

RECOMMENDATIONS:



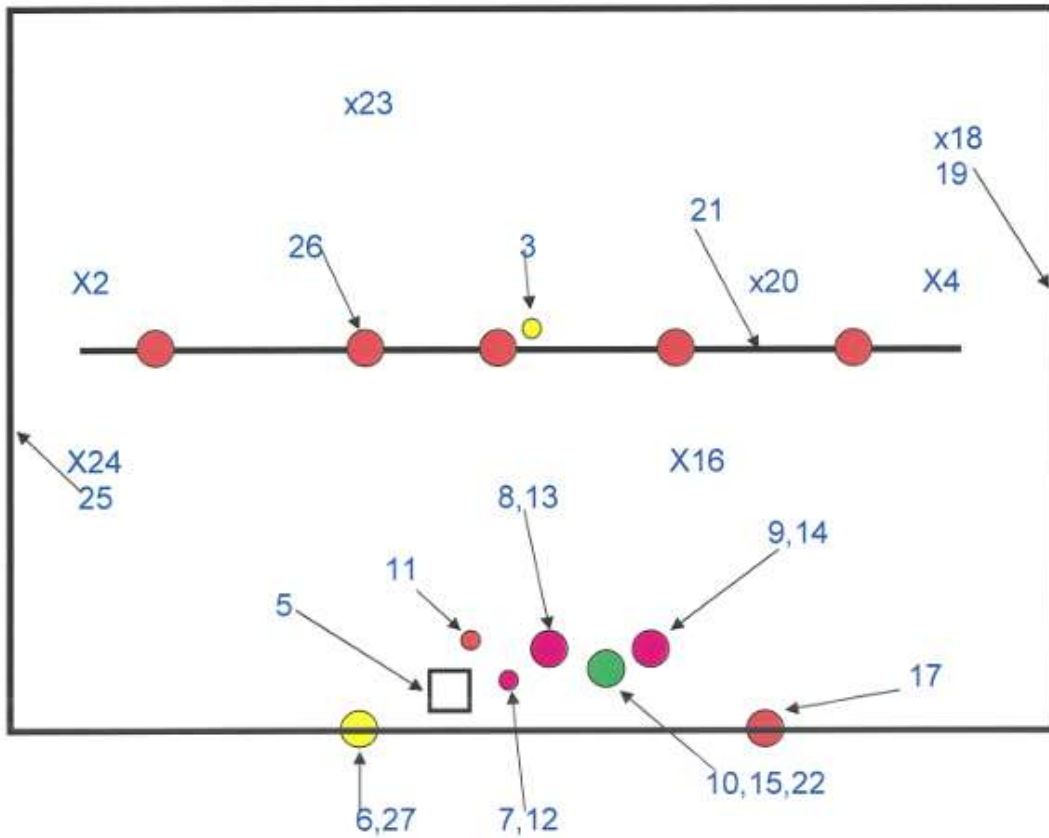

Recommendation	Estimated Time - Hrs.
Perform a regular cleaning, inspection and repair cycle every 2-3 years in order to ensure superior water quality and proper maintenance of coating condition and appurtenances is performed.	Please contact our sales office for an estimate.
Other	
Total Estimated Hours	

Estates 2

1 Reservoir Diagram



Drawing Not To Scale

	Entry Hatch		Overflow		Air Vent
	Inlet		Telemetry		Outlet
	Crossover		Slump		

Estates 2

Image #
1



Image #
2



Estates 2

Image #
3



Image #
4



Estates 2

Image #
5



Image #
6



Estates 2

Image #
7



Image #
8



Estates 2

Image #
9



Image #
10



Estates 2

Image #
11



Image #
12



Estates 2

Image #
13



Image #
14



Estates 2

Image #
15



Image #
16

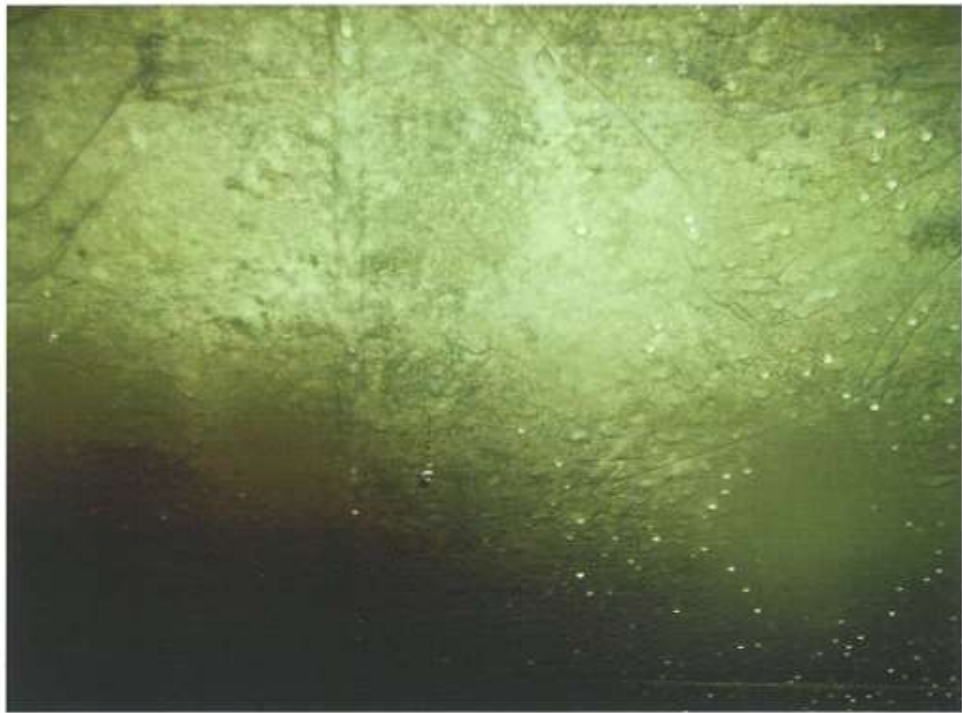

Estates 2

Image #
17



Image #
18

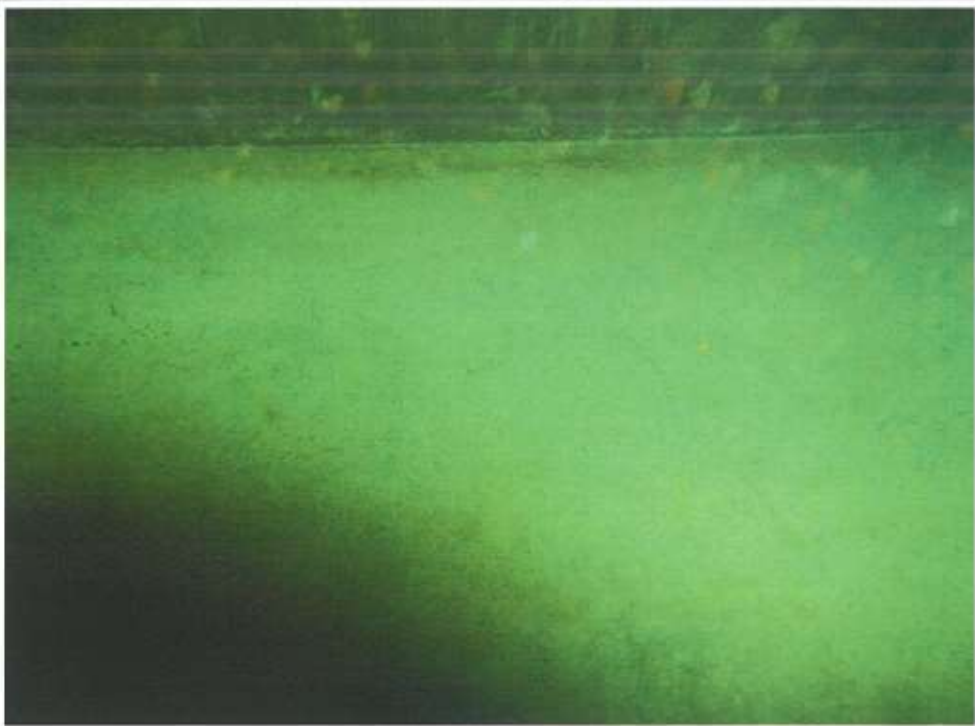

Estates 2

Image #
19



Image #
20



Estates 2

Image #
21



Image #
22



Estates 2

Image #
23

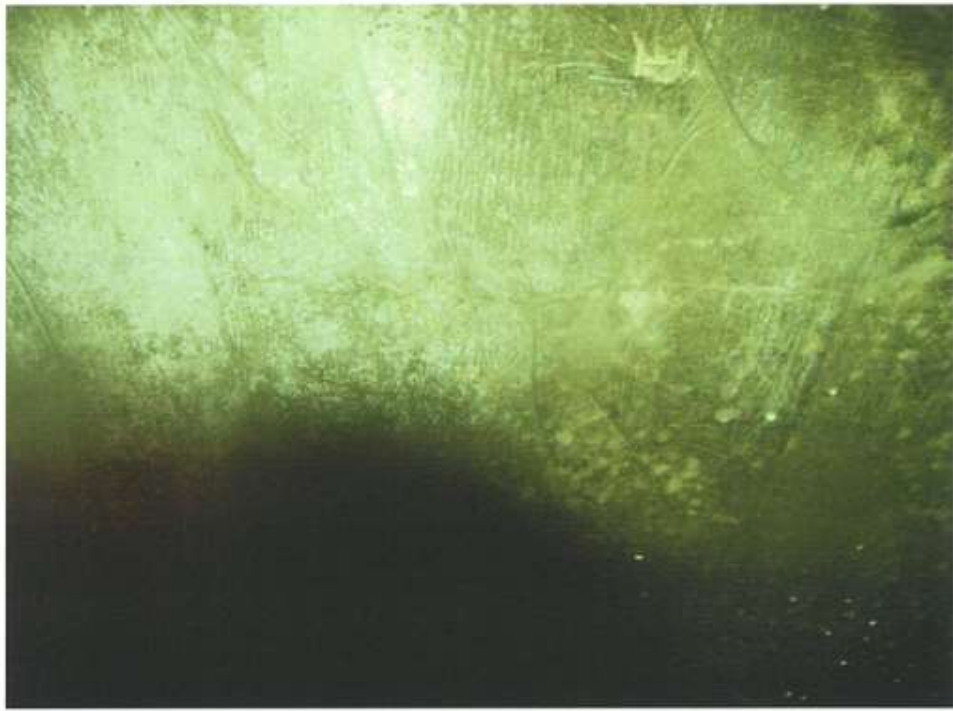

Image #
24



Estates 2

Image #
25

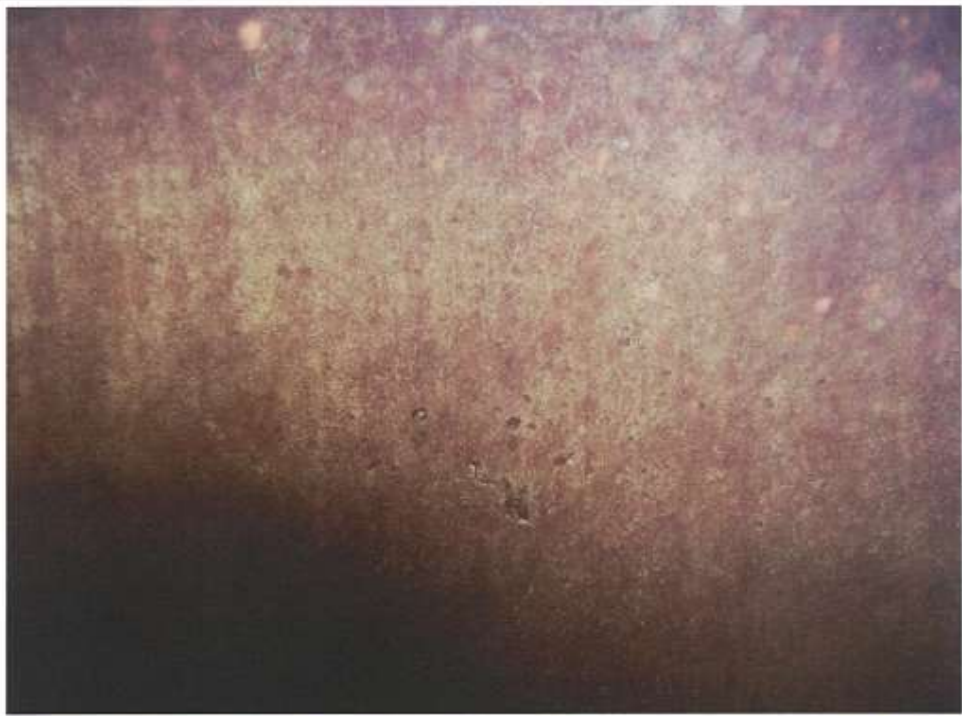

Image #
26



Estates 2

Image #
27



Estates 2

REFERENCES

**Standard Method of Evaluating Degree of Rusting on Painted Steel Surfaces
– SSPC-Vis 2-82 & ASTM D 610-85 (1989)**

The graphical representations show examples of area percentages, which may be helpful in rust grading. The use of photographic reference standards requires the following precautions:

1. Some finishes are stained by rust. This staining must not be confused with the actual rusting involved.
2. Accumulated dirt or other material may make accurate determination of the degree of rusting difficult.
3. Certain types of deposited dirt that contain iron or iron compounds may cause surface discoloration that should not be mistaken for corrosion.
4. It must be realized that failure may vary over a given area and discretion must therefore be used in applying these reference standards.
5. In evaluating surfaces, consideration shall be given to the color of the finish coating, since failures will be more apparent on a finish that shows color contrast with rust, such as white, than on a similar color, such as iron oxide finish.
6. The photographic reference standards are not required for use of the rust-grade scale since the scale is based upon the percent of the area rusted and any method of assessing area rusted may be used to determine the rust grade.

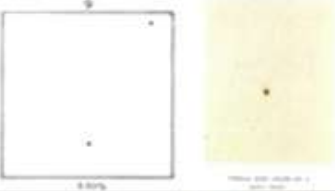
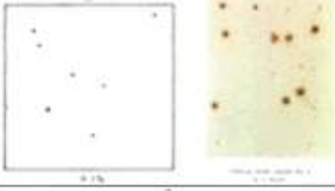
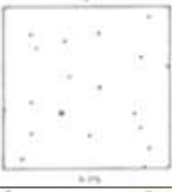
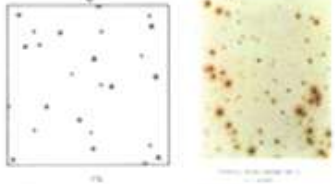
Rust Grades ^A	Description	Graphical Representation
10	No rusting or less than 0.01% of surface rusted	Unnecessary
9	Minute rusting, less than 0.03% of surface rusted	
8 ^B	Few isolated rust spots, less than 0.1% of surface rusted	
7	Less than 0.3% of surface rusted	
6 ^C	Extensive rust spots, but less than 1% of surface rusted	

Estates 2

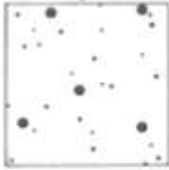
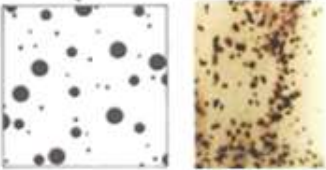
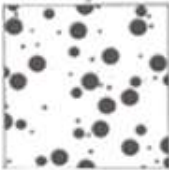
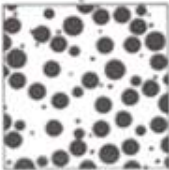
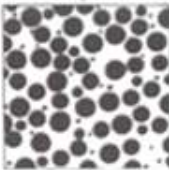
5	Rusting to the extent of 3% of surface rusted	
4 ^D	Rusting to the extent of 10% of surface rusted	
3 ^E	Approximately on sixth of the surface rusted (16%)	
2	Approximately one third of the surface rusted (33%)	
1	Approximately one half of the surface rusted (50%)	
0 ^F	Approximately 100% of the surface rusted	Unnecessary

- A. Similar to European Scale of Degree of rusting for Anti-Corrosive Paints (1961) (black and white).
- B. Corresponds to SSPC Initial Surface Conditions E (0 to 0.1%) and BISRA (British Iron and Steel Research Association) 0.1%.
- C. Corresponds to SSPC Initial Surface Conditions F (0.1% to 1%) and BISRA 1.0%.
- D. Corresponds to SSPC Initial Surface Conditions G (1 to 10%).
- E. Rust grades below 4 are of no practical importance in grading performance of paints.
- F. Corresponds to SSPC Initial Surface Condition H (50 to 100%).

Estates 2

Cathodic Protection Definitions – NACE Standard RP0196-96 & RP0388-2001

Anode: The electrode of an electrochemical cell at which oxidation occurs. Electrons flow away from the anode in the external circuit. Corrosion usually occurs and metal ions enter the solution at the anode.

Anode Circuit: The path from a single anode or multiple anodes connected through a shunt, a resistor, and the connection to the tank.

Calcareous Coating: A layer consisting of calcium carbonate and other salts deposited on the surface. When the surface is cathodically polarized as in cathodic protection, this layer is the result of the increased PH adjacent to the protected surface.

Cathode: The electrode of an electrochemical cell at which reduction is the principal reaction. Electrons flow toward the cathode in the external circuit.

Cathodic Disbondment: The destruction of adhesion between a coating and the coated surface caused by products of cathodic protection.

Cathodic Protection: A technique to reduce the corrosion of a metal surface by making that surface the cathode of an electrochemical cell.

Coating: All components comprising the protective coating system, the sum of which provides effective electrical insulation of the coated structures from the electrolyte.

Conductivity: A measure of the ability of a material to carry an electric current. In water, this depends on the total concentration of the ionized substances dissolved and the temperature at which the measurement is made. It is the reciprocal of resistivity and is usually expressed in umhos/cm (uS/cm).

Corrosion: The deterioration of a material, usually a metal, that results from a reaction with its environment.

Current Density: The current to or from a unit area of an electrode surface.

Driving Voltage: The potential difference between the galvanic anodes and the tank wall when the cathodic protection system is in operation.

Electrode: A conductor used to establish electrical contact with an electrolyte and through which current is transferred to or from electrolyte.

Electrode Potential: The potential of an electrode in an electrolyte as measured against a reference electrode. (The electrode potential does not include and resistance losses in potential in either the solution or the external circuit. It represents the reversible work to move a unit of charge from the electrode surface through the electrolyte to the reference electrode.)

Electrolyte: A chemical substance containing ions that migrate in an electric field. For the purpose of this standard, electrolyte refers to the water, including the dissolved chemicals, in the tank.

Galvanic Anode: A metal that provides sacrificial protection to another metal that is more noble when electrically coupled in an electrolyte. This type of anode is the current source in one type of cathodic protection.

Holiday: A discontinuity in a protective coating that exposes unprotected surface to the environment. For the purpose of this standard, it is a bare spot in a coating that exposes tank internal metal surface to the stored water.

Impressed Current: An electric current supplied by a device employing a power source that is external to the electrode system. (An example is direct current for cathodic protection.)

Impressed Current Anode: An anode, usually composed of substantially inert materials, that is supplied with impressed current.

IR Drop: The voltage across a resistance in accordance with Ohm's law.

Estates 2

Polarization: The change from the open-circuit potential as a result of current across the electrode/electrolyte interface.

Polarized Potential: The potential of the tank that is the result of passage of cathodic protection current independent of the voltage drop in the electrolyte.

Reference Electrode: An electrode whose open-circuit potential is constant under similar conditions of measurement, which is used for measuring the relative potentials of other electrodes.

Resistivity: A measure of the specific resistance of a material to the passage of electric current. It is usually expressed in ohm-centimeters (ohm-cm) and is the reciprocal of conductivity.

Tank to Water Potential: The voltage difference between a submerged metallic portion of the tank and the water (electrolyte), which is measured with a reference electrode in contact with the water.

Estates 2

Weld Surface Conditions - AWS B1.11:2000 (An American National Standard)

Porosity: Porosity is a cavity-type discontinuity formed by gas entrapment during solidification or in a thermal-spray deposit. The discontinuity formed is generally spherical and may be elongated.

Scattered Porosity: Scattered porosity is porosity, which is uniformly distributed throughout the weld metal.

Cluster Porosity: Cluster porosity is a localized array of porosity having a random geometric distribution.

Piping Porosity: Piping porosity is a form of porosity having a length greater than its width that lies approximately perpendicular to the weld face. Also known as wormhole porosity.

Aligned Porosity: Aligned porosity, which is a localized array of porosity oriented in a line. The pores may be spherical or elongated. Aligned porosity is sometimes referred to as linear porosity.

Elongated Porosity: Elongated porosity, which is a form of porosity having a length greater than its width that lies approximately parallel to the weld axis.

Incomplete Fusion: Incomplete fusion is a weld discontinuity in which fusion did not occur between weld metal and fusion faces or adjoining weld beads.

Incomplete Joint Penetration: Incomplete joint penetration is joint root condition which weld metal does not extend through the joint thickness. The impenetrated and unfused area is a discontinuity described as incomplete joint penetration.

Undercut: Undercut is a groove melted into the base metal adjacent to the weld toes or weld root and left unfilled by weld metal. This groove creates a mechanical notch, which is a stress concentrator.

Underfill: Underfill is a condition in which the weld face or root surface of a groove weld extends below the adjacent surface of the base metal.

Overlap: Overlap is the protrusion of unfused weld metal beyond the weld toe or weld root. Overlap is surface discontinuity that forms a mechanical notch and is nearly always considered rejectable.

Lamination: Lamination is a type of base-metal discontinuity with separation or weakness generally aligned parallel to the worked surface of a metal.

Seams and Laps: Seams and laps are base metal discontinuities that may be found in rolled, drawn, and forged products. They differ from laminations in that they appear on the surface of the worked product.

Cracks: Cracks are defined as fracture-type discontinuities characterized by a sharp tip and high ratio of length and width to opening displacement.

Longitudinal Cracks: Cracks that are parallel to the weld axis regardless of whether it is a centerline crack in weld metal or a toe crack in the base metal heat-affected zone.

Transverse Cracks: Cracks that are perpendicular to the axis of the weld. These may be limited in size and contained completely within the weld metal if they may propagate from the weld metal into the adjacent heat-affected zone and further into the base metal.

Hot Cracks: Hot cracks develop during solidification and are the result of insufficient ductility at high temperature. Hot cracks propagate between grains in the weld metal or at the weld interface.

Cold Cracks: Cold cracks develop after solidification

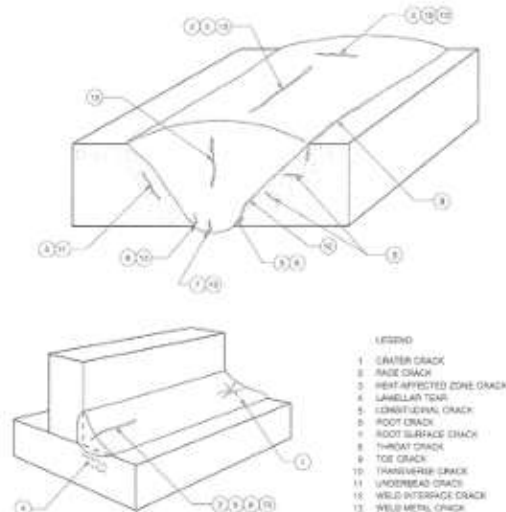

Estates 2

is complete. The cracks can form hours or even days after the weld is completed. Cold cracks propagate both between grains and through grains.

Throat Cracks: Throat cracks are longitudinal cracks oriented along the throat of fillet welds. They are generally, but not always hot cracks.

Root Cracks: Root cracks are longitudinal cracks at the weld root or in the root surface. They may be hot or cold cracks.

Crater Cracks: Crater cracks occur in the crater of a weld when the welding is improperly terminated. They are sometimes referred to as star cracks though they may have other configurations. Crater cracks are hot cracks usually forming a pronged star-like network.

Toe Cracks: Toe cracks are generally cold cracks. They initiate and propagate from the weld toe where shrinkage stresses are concentrated.

Underbead and Heat-Affected-Zone Cracks: Underbead and heat-affected-zone cracks are generally used interchangeably. They are generally cold cracks that form in the heat-affected zone of the base metal.

Slag Inclusions: Slag inclusions are nonmetallic products resulting from the mutual dissolution of flux and nonmetallic impurities in some welding and brazing processes.

Excessive Reinforcement: In groove welds, weld reinforcement is weld metal in excess of the quantity required to fill a joint. Weld reinforcement can be located at either the weld face or weld root surface, and is called face reinforcement and root reinforcement, respectively.

Convexity: Convexity is the maximum distance from the face of a convex fillet weld perpendicular to a line joining the weld toes.

Concavity: Concavity is the maximum distance from the face of a concave filled weld to a line joining the weld toes.

Arc Strikes: An arc strike is a discontinuity consisting of any localized remelted metal, heat affected metal, or change in the surface profile of any part of a weld or base metal resulting from an arc.

Spatter: Spatter consists of metal particles expelled during fusion welding that do not form a part of the weld.

Melt-Through: Melt through is visible root reinforcement produced in a joint welded from one side.

Weld Size: Weld size is a measure of critical dimension, or combination of critical dimensions of a weld.

Surface Oxidation: Surface oxidation of stainless steels and nickel alloys occurs whenever these alloys are exposed to the atmosphere while above 1000 degrees F known as sugaring with it becomes heavy.

Estates 2

Concrete Deformities Definitions – ACI 201.1R-92

Crack: A complete or incomplete separation of either concrete or masonry, into two or more parts produced by breaking or fracturing.

Checking: Development of shallow cracks at closely spaced but irregular intervals on the surface of plaster, cement paste, mortar or concrete.

Craze Cracks: Fine random cracks or fissures in a surface of plaster, cement paste, mortar or concrete.

Crazing: The development of craze cracks; the pattern of craze cracks existing in a surface.

D-Cracking: A series of cracks in concrete near and roughly parallel to joints, edges, and structural cracks.

Diagonal Crack: In flexural member, an inclined crack caused by shear stress, usually at about 45 deg to the axis; or a crack in a slab, not parallel to either the lateral or longitudinal directions.

Hairline Cracks: Cracks in an exposed concrete surface having widths so small as to be barely perceptible.

Pattern Cracking: Fine openings on concrete surfaces in the form of a pattern; resulting from a decrease in volume of the material near the surface, or increase in volume of the material below the surface, or both.

Plastic Cracking: Cracking that occurs in the surface of fresh concrete soon after it is placed and while it is still plastic.

Shrinkage Cracking: Cracking of a structure or member due to failure in tension caused by external or internal restraints as reduction in moisture content develops, or as carbonation occurs or both.

Temperature Cracking: Cracking due to tensile failure, caused by temperature gradient in members subjected to external restraints or by temperature differential in members subjected to internal restraints.

Transverse Cracks: Cracks that develop at the right angles to the long direction of the member.

Deterioration: 1) Physical manifestation of failure of a material (e.g., cracking, delamination, flaking, pitting, scaling, spalling, straining) caused by environmental or internal autogenous influences on hardened concrete as well as other materials; 2) Decomposition of material during either testing or exposure to service.

Disintegration: Reduction into small fragments and subsequently into particles.

Abrasion Damage: Wearing away of a surface by rubbing and friction.

Blistering: The irregular raising of a thin layer, frequently 25 to 300 mm in diameter, at the surface of placed mortar or concrete during or soon after completion of the finishing operation; blistering is usually attributed to early closing of the surface and may be aggravated by cool temperatures. Blisters also occur in pipe after spinning or in a finish plastic coat in plastering as it separates and draws away from the base coat.

Cavitation damage: Pitting of concrete caused by implosion, i.e., the collapse of vapor bubble in flowing water, which form in areas of low pressure and collapse as they enter areas of higher pressure.

Chalking: Formation of a loose powder resulting from the disintegration of the surface of concrete or of applied coating, such as cement paint.

Corrosion: destruction of metal by chemical, electrochemical or electrolytic reaction with its environment.

Curling: The distortion of an originally essentially linear or planar member into a curved shape such as the warping of a slab due to creep or to differences in temperature or moisture content in the zones adjacent to its opposite faces.

Deflection: Movement of a point on a structure or structural element, usually measured as a linear displacement transverse to a reference line or axis.

Deformation: A change in dimension or shape.

Delamination: A separation along a plane parallel to a surface as in the separation of a coating from a substrate or the layer of a coating from each other, or in the case of a concrete slab, a horizontal splitting,

Estates 2

cracking or separation of a slab in a plane roughly parallel to, and generally near, the upper surface; found frequently in bridge decks and other types of elevated reinforced-concrete slabs and may be caused by the corrosion of reinforcing steel; also found in slabs on grade caused by development, during the finishing operation, of a plane of weakness below the densified surface; or caused by freezing and thawing, similar to spalling, scaling, or peeling except that delamination affects large areas and can often be detected by tapping.

Distortion: See Deformation

Dusting: The development of powdered material at the surface of hardened concrete.

Efflorescence: A deposit of salts, usually white, formed on a surface, the substance having emerged in solution from within either concrete or masonry and subsequently been precipitated by evaporation.

Erosion: Progressive disintegration of a solid by the abrasive or cavitation action of gases fluids or solids in motion.

Exfoliation: Disintegration occurring by peeling off in successive layers; swelling up and opening into leaves or plates like a partly opened book.

Exudation: A liquid or viscous gel-like material discharged through a pore, crack, or opening in the surface of concrete.

Joint Spall: A spall adjacent to a joint.

Pitting: Development of relatively small cavities in a surface; in concrete, localized disintegration, such as a popout; in steel, localized corrosion evident as minute cavities on the surface.

Peeling: A process in which thin flakes of mortar are broken away from a concrete surface, such as by deterioration or by adherence of surface mortar to forms as forms are removed.

Popout: The breaking away of small portions of a concrete surface due to localized internal pressure, which leaves a shallow, typical conical, depression.

Popouts, Small: Popouts leaving holes up to 10 mm in diameter, or the equivalent.

Popouts, Medium: Popouts leaving holes between 10 mm and 50 mm in diameter, or the equivalent.

Popouts, Large: Popouts leaving holes greater than 50 mm in diameter, or the equivalent.

Scaling: Local flaking or peeling away of the near-surface portion of hardened concrete or mortar; also of a layer from metal.

Scaling, Light: Loss of surface mortar without exposure of coarse aggregate.

Scaling, Medium: Loss of surface mortar 5 to 10 mm in depth and exposure of coarse aggregate.

Scaling, Severe: Loss of surface mortar 5 to 10 mm in depth with some loss of mortar surrounding aggregate particles 10 to 20 mm in depth.

Scaling, Very Severe: Loss of coarse aggregate particles as well as mortar, generally to a depth greater than 20 mm.

Spall: A fragment, usually in the shape of a flake, detached from a larger mass by a blow, by the action of weather, by pressure, or by expansion within the large mass.

Small Spall: A roughly circular depression not greater than 20 mm in depth nor 50 mm in any dimension.

Large Spall: May be roughly circular or oval or in some cases elongated, more than 20 mm in depth and 150 mm in greatest dimension.

Warping: A deviation of a slab or wall surface from its original shape, usually caused by either temperature or moisture differentials or both within the slab or wall.