

BEFORE THE
WASHINGTON UTILITIES & TRANSPORTATION COMMISSION

UG-__
GENERAL RATE APPLICATION
OF
NORTHWEST NATURAL GAS COMPANY

December 31, 2018

Direct Exhibit of Andrew C. Middleton

ENVIROMENTAL MITIGATION HISTORY

Exh. ACM-3

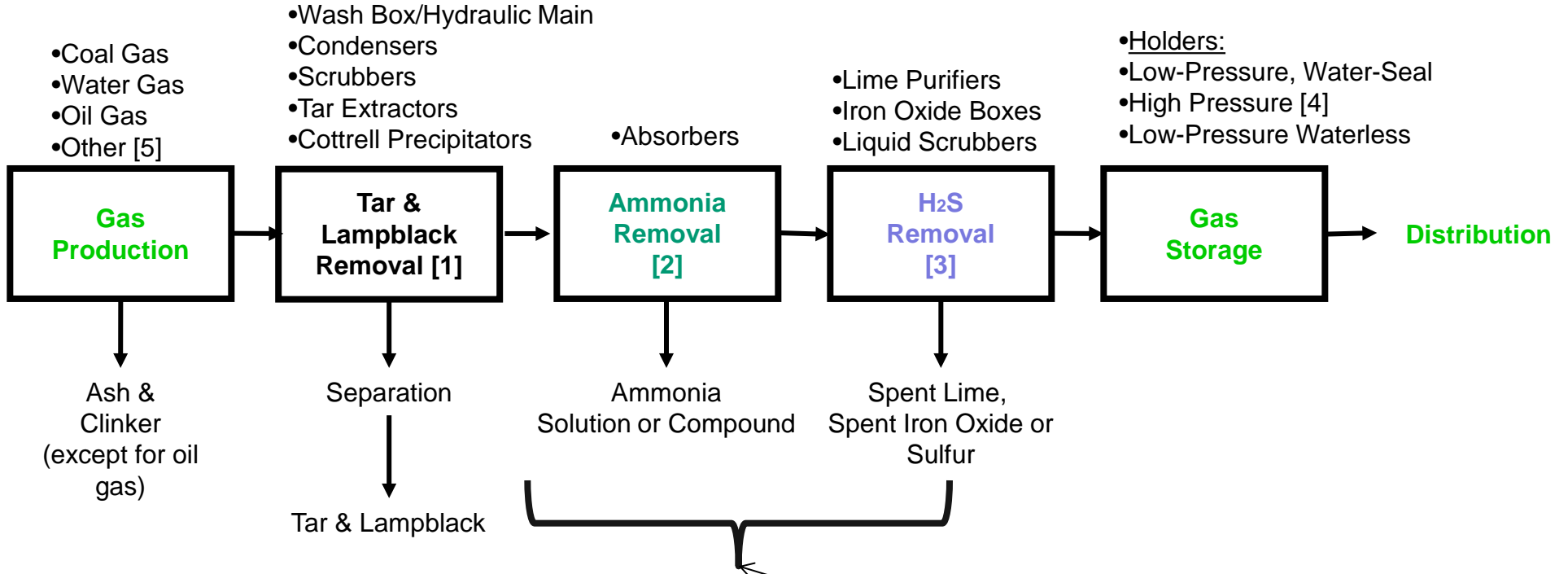

- Notes:
- [1] Not all of these processes were necessarily at an MGP; water gas included a relief holder in this step to equalize gas flow from cyclical production; lampblack removal was for oil gas manufacture
 - [2] In coal gas processes only; water gas and oil gas did not typically contain significant ammonia
 - [3] For coal gas and oil gas using crude oil, cyanide would also be removed here; water gas did not typically contain significant cyanide
 - [4] Pressurization of manufactured gas generated condensate
 - [5] Depending on which other process, the gas purification steps may have varied from this diagram
- Light Oil and/or Naphthalene recovery might also be incorporated in the gas purification steps depending on the process and scale of gas manufacture.

Exhibit 2: Schematic Diagram of the Overall General Gas Manufacturing, Purification and Storage Processes