

GENERATION PROTECTION AND CONTROL EQUIPMENT INSTALLATION PROCEDURE

GPCP-EQPMNT-INST

Version number: 1
Approval date: 10/03/2012
Authoring department: Generation Protection & Relay Support
Approved location: P8
File name: GPCP-EQPMNT-INST

Revision Log		
0	10/03/2012	Original procedure file "GPCP-EQPMNT-INST" created from <i>Protection and Control Services</i> department document PCP-EQPMNT-INST.
1		

PROTECTION AND CONTROL EQUIPMENT INSTALLATION PROCEDURE

1 Scope

This document provides the general guidelines and procedures required to test and verify the protection and control equipment associated with equipment installation.

2 References

- 2.1 Utilize manufactures manuals and reference material.
- 2.2 Relay settings issued by the protection and control engineer.

3 Precautions

- 3.1 Follow PacifiCorp's safe work practices.
- 3.2 Before measuring resistance with a multimeter, always check for standing voltage across open contacts.
- 3.3 Contact the appropriate PacifiCorp Company representative if any equipment fails to perform as designed or any equipment is inconsistent with the issued substation construction drawings.

4 Equipment Used

- 4.1 Current and voltage inservice test meters are needed if current or voltage quantities are included in this installation.
- 4.2 Current transformer excitation, ratio and polarity test set or equivalent is needed if current transformer(s) are included with this installation.

5 Required Documentation

All forms and any test set generated reports shall be forwarded to the company representative and to genrelspprt@pacificorp.com. Test results shall be submitted in electronic format as well as part of the pdf document. A single pdf document will be created that contains the pass/fail test summary from Pro Test and all the applicable forms from the list below. The current revisions of the relay maintenance and installation procedures, forms and policies are primarily available in P8.

- 5.1 Completed current transformer test form, GPCF-CT-INST, Current Transformer Installation. Required if current transformers are included in this installation.
- 5.2 Relay Commissioning Checklist GPCF-RLY-INST.
- 5.3 All final plant and/or substation as-constructed drawings must be clearly marked-up and modified to reflect the exact equipment installed details.

6 Procedure

Perform the following sections that apply to this application.

6.1 Visual Inspection

Visually inspect all relays, board instruments, transducers, meters, equipment control cabinet, and any modified or new relay control panels for damage that may have occurred during shipping and installation.

6.2 Relay and Control Panel

Perform the following relay and control panel inspections and tests.

6.2.1 Panel Equipment Installation

Verify relays, equipment, and nameplates are installed on the panel as documented in the panel layout and connection diagram.

6.2.2 Wiring Verification

On all new or modified panels count the number of wires on each terminal and verify the number of wires conforms to the connection diagram. Perform point-to-point wire checks on all new or modified panels. Point-to-point verification may be performed by a manufacturer, contractor, or PacifiCorp technician, and need only be performed once. Verify modified wiring matches the connection diagram and control schematics.

6.2.3 Panel Wire Lugs

Verify that all new and modified panel wiring lugs are adequately crimped.

6.2.4 Panel Terminal Blocks

Verify that all new and modified panel wiring terminal block connections are checked for tightness.

6.2.5 Panel Current Transformer Circuit Tests

For each new or modified relay control panel, measure the DC resistance of each CT (current transformer) circuit from the panel input terminal blocks. Open associated current test switches and manipulate any rotary switches used in the associated CT circuit, so long as manipulating the switch does not introduce connectivity to an energized CT circuit. This test is to ensure that the CT circuits are not open-circuited. The measured DC resistance of each circuit should be less than 5 ohms.

6.2.6 Panel Voltage Transformer Circuit Tests

For each new or modified relay control panel, measure the DC resistance of each VT (voltage transformer) circuit from the panel input terminal blocks. Measurements should take place between phase-to-ground and phase-to-phase. This test is to ensure that the VT circuits are not short-circuited. The measured DC resistance of this circuit should be greater than 1000 ohms.

6.2.7 Panel DC Circuit Tests

Measure the DC resistance of the DC control power circuit from the panel input (DC positive and DC negative) terminal blocks. This test is to ensure that the DC circuit is not short-circuited. The measured DC resistance of this circuit should be greater than 10 ohms.

6.3 Current Transformer Testing

Test all new current transformer installations that are included with this circuit breaker. Follow installation test procedure PCP-CT-INST Current Transformer Installation, and complete test form PCF-CT-INST Current Transformer Installation.

6.4 Current Transformer Secondary Circuit Testing

Test all current transformer secondary wiring and devices that are included with this equipment installation.

6.4.1 Current Transformer Secondary Wiring

Verify all secondary CT wiring matches the substation connection diagrams and control schematics. Ensure correct CT ratio, polarity, and grounding.

6.4.2 Secondary Current Transformer Loading Test

Load each secondary CT circuit with five amps of AC current. Verify proper magnitude and direction of current at each relay and metering device in the CT circuit. Spot-check the other unloaded phases to verify that the current is zero. For circuits with electromechanical relays only, calculate burden on each CT circuit. See figure 1 below.

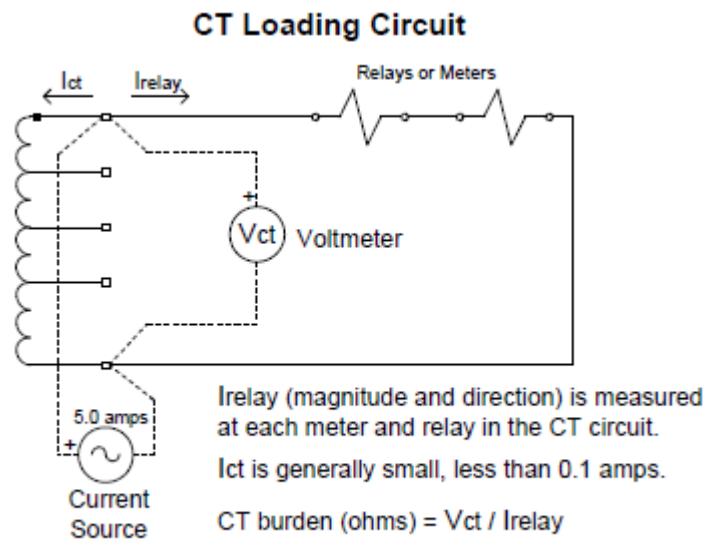

Figure 1

6.5 Voltage Transformer Secondary Testing

Verify all voltage transformer secondary equipment and wiring that is included with this equipment installation.

6.5.1 Voltage Transformer Secondary Wiring

Verify all secondary VT wiring matches the substation connection diagrams and control schematics. Ensure correct VT ratio, polarity, and grounding.

6.5.2 Voltage Transformer Secondary Resistance Test

At the voltage transformer, measure the secondary circuit DC resistance for each phase-to-phase and phase-to-ground circuit. This test is to verify that a circuit-short does not exist.

6.6 Control Logic

The control logic operation must match the equipment control schematic and relay settings.

6.6.1 Using the issued control schematics verify all remote and local control, indication, alarms and logic inputs/outputs. Use a highlighter to mark the control schematic as they are verified. The highlighted control schematic should be included in the installation documentation.

6.7 Dispatch Metering, Indication, and Control

Verify the dispatch metering, indication, and control for this equipment.

6.7.1 Required Checkouts for Modified Equipment

SCADA checkout of affected points must occur under the following circumstances that may cause a change in SCADA functionality.

- New points are added;
- Existing points are reused for new functions; or
- Analog full-scale value changes due to hardware or setting change such as a modification of a CT or PT ratio.

Coordinate with BSAs (Business System Analysts) to test affected SCADA points. The BSA can provide a list of all new points which are to be tested. To find BSA, search intranet directory and in title box enter "Sr BusSys/EMS" for a complete list of BSAs.

6.7.2 Control and Indication

Verify with the BSAs the functionality of all modified or added SCADA control points up through their respective devices. This includes trip and close, tag on and off, reclose on and off, and reset functions.

Verify with the BSAs the functionality of all indication/status points. Include equipment opened and closed, tag on or off, recloser on or off, relay failure normal or alarm, etc. The breaker stored energy alarm should be blocked when the 01 control switch is in the turn-to-latch position.

6.7.3 Dispatch Metering

Verify metering quantities to dispatch for proper function and accuracy associated with the installed equipment. Remote metering quantities should operate with no more than $\pm 5.0\%$ error at 0 and 25-100% of full scale. If test

switches are not available to inject test quantities prior to energization, mark as "N/A", make a note in the comments section, and complete verification after energization.

6.8 Complete the Relay Package Maintenance Procedure PCP-RLY-MAINT-GENERAL or PCP-RLY-MAINT-XFMR and their associated forms, PCF-RLY-MAINT-GENERAL or PCF-RLY-MAINT-XFMR for the installed equipment.

6.9 Drawings and Equipment Memorandums

Complete the as-built drawings and submit any Equipment Memorandums for this equipment installation. Drawings must be clearly marked up and modified to reflect the exact substation equipment installation details. If complete as-built drawings are not available until after energization, mark as "N/A", make a note in the comments section, and submit drawings after energization.

6.10 Retired Critical Relays

As per NERC CIPS standards, if any critical relays are removed from service during this equipment installation, the relay settings shall be removed or the relay destroyed.

7 Commissioning Records Retention

Submit all required test reports and installation forms by email to the "Commissioning" mailbox. If this commissioning work has an associated project notebook, determine the proper file and email subject naming convention, either from 1) the Project Notebook spreadsheet associated with the project, or 2) the "Commissioning Documents Naming Convention" document found in the Project Notebook Sharepoint site by clicking the "Home Page" tab at the top of the Project Notebook screen, or by following this [link](#). This includes all ProTest records and forms referred to in this procedure.